

**Engine Tools**

**Air Induction..... 3-3**

**Cooling System ..... 3-19**

**Crankshaft, Main Bearings and Flywheel ..... 3-44**

**Cylinder Block and Liners ..... 3-77**

**Cylinder Head, Valves and Cam Followers..... 3-103**

**Electrical and Ignition Tools ..... 3-169**

**Lube System..... 3-175**

**Engine Test Tools..... 3-180**

**Fuel System Test Tools ..... 3-202**

**Fuel System Repair and Adjust..... 3-243**

**Pistons, Rings and Connecting Rods ..... 3-317**

**Camshaft and Timing Gear Tools ..... 3-337**

**Starting Systems..... 3-354**

**Engine Lifting and Positioning ..... 3-356**

**3600 Engine Tools ..... 3-376**

**Engine Tools**



Air Induction

**FT1984 Pressurizing Group**

Model: 3176, 3208, 3304B, 3306B, 3406B

Warranty: None

- Used to test air-to-air aftercoolers on 3306B and 3406B Truck Engines
- Aids in detecting defects in air-to-air aftercoolers
- Includes complete parts description and parts sourcing information

**Reference**

SEHS8622, Special Instruction

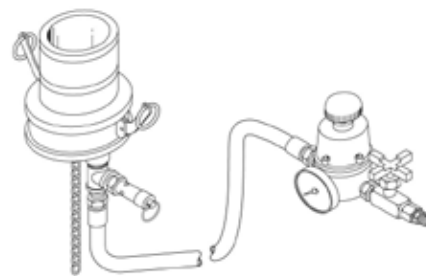

**367-7435, 378-4525, 378-4526**

**Aftercooler Testing Plugs**

Model: All C9.3 through C18 Tier 4 Engines

Warranty: Six Months

- Used to seal aftercoolers in order to apply pressurization for performing an under water leak check to determine reusability of the aftercooler

Expandable Plug Chart - Specifications

Part Number	367-7435	378-4525	378-4526
Size	2 x 1 5/16 in	1 3/8 x 1 5/16 in	2 x 1 5/16 in
Rubber Dia.	49 mm (1.93 in)	33.5 mm (1.32 in)	49 mm (1.93 in)
Body Length	28.7 mm (1.13 in)	33.3 mm (1.31 in)	28.7 mm (1.13 in)
Flange Dia.	62 mm (2.44 in)	44.5 mm (1.75 in)	62 mm (2.44 in)
Top Plate Dia.	65 mm (2.56 in)	47.8 mm (1.88 in)	65 mm (2.56 in)
Height	37.3 mm (1.47 in)	33.3 mm (1.31 in)	37.3 mm (1.47 in)
Weight	.181 kg (.4 lb)	.181 kg (.4 lb)	.181 kg (.4 lb)

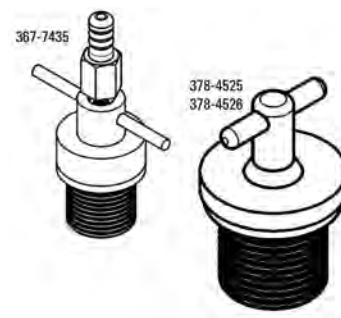

Part Number	Description
378-4525	Aftercooler Testing Plug
378-4526	Aftercooler Testing Plug
367-7435	Aftercooler Testing Plug

**321-6022 Pressurizer Assembly**

**Essential Tool**

Model: 793F, 795F, and 797F Off-Highway Truck

Warranty: Six Months

- Used to seal air induction system to test for air leaks temporarily — replaces primary and secondary air filters
- Used with shop air supply and dealer supplied 0 to 70 kPa (0 to 10 psi) pressure gauge
- Requires one pressurizer tool for each air cleaner (797F Off-Highway Truck requires five tools)
- Each tool features a quick-disconnect air fitting and a preset pressure relief valve
- 9H-5548 O-ring Seal is serviced separately

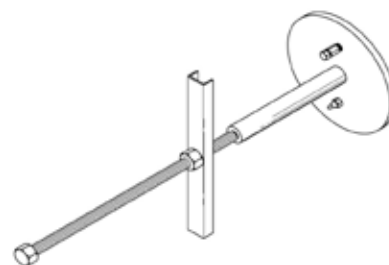

Part Number	Description
321-6022	Pressurizer Assembly

## 152-2067 Differential Pressure Gauge

Model: Multiple Engine Models

Warranty: Six Months

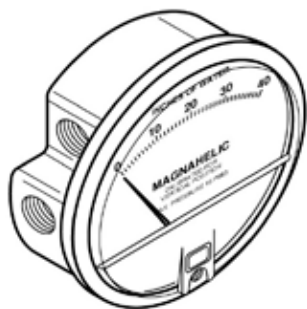

- Used to monitor aftercooler pressure drop in applications with crankcase fumes recirculation
- Minimize risk of engine reliability problems
- Helps eliminate premature plugging of aftercooler cores
- Increase service life of air cleaner
- Eliminates need for using two gauges
- Installs easily across air side of aftercooler core
- Measures differential pressure continuously, regardless of fluctuation in system pressure
- For maximum accuracy, calibrate gauge in position used
- Magnahelic gauge with high pressure option

Accuracy	±2% of full scale
Weight	.51 kg (18 oz)
Range	0 - 101 cm (0 - 40 in) of water
Minor divisions	1.0
Temperature range	(-6° to 60° C) 20° to 140° F
Maximum pressure	551 kPa (80 psi)

Part Number	Description
152-2067	Differential Pressure Gauge

## Turbocharging Reconditioning Tools

Model: Multiple Engine Models

Warranty: Six Months

The tools needed to service a particular turbocharger can be determined from the following charts.

### Reference

SMHS6854, Special Instruction

Part No.	Description	3LK	4, 4A, 4C	4B, 4D	V4HD, V4MD	4MD, 4ME	4HD	F, E
FT0165 <sup>1</sup>	Fixture (Modified)	X	X	X	X	X	X	X
FT0165	Fixture		X	X	X	X	X	X
FT0168	Adapter			X				X
FT0170	Support Screw		X	X	X	X	X	
FT0174	Driver Tool		X	X	X	X	X	
FT0175	Expander Sleeve		X	X	X	X	X	
FT0623	Removal Tool					X	X	
FT0626	Spacer Block	X	X	X	X	X		
FT0745	Pliers, Modified		X	X	X	X	X	X
FT0808	Adapter	X	X		X			

<sup>1</sup> FT0165 (Modified) replaces FT0165 Turbo Fixture

Part Number	Description	3LK	4 4A 4C	4B 4D	V4HD V4MD	4MD 4ME	4HD	F E
9S-6343	Cartridge Fixture <sup>1</sup>	--	--	--	--	X	X	X
9S-6363	Fixture Group <sup>2</sup>	--	--	--	--	X	X	X

(Continued)



**Turbocharging Reconditioning Tools (Continued)**

Model: Multiple Engine Models

Warranty: Six Months

<sup>1</sup>9S-6343 replaced FT0622

<sup>2</sup>9S-6363 replaced FT0621

**Manufacturer: AiResearch**

Part No.	Description	T6	T12	T114	T18	T24	T3019	T04	TV81	TW81
FT0165 <sup>1</sup>	Fixture (Modified)	X	X	X	X	X	X	X	X	X
FT0165	Fixture	X	X	X	X	X	X			
FT0168	Adapter	X	X							
FT0170	Support Screw		X	X	X	X	X			
FT0174	Driver Tool	X	X	X	X	X	X		X	X
FT0745	Pliers, Modified	X	X	X	X				X	X
FT0808	Adapter							X		
FT1354	Adapter								X	X
9S-6363	Fixture Group		X						X	X
9S-6343	Cartridge Fixture		X						X	X

<sup>1</sup> FT0165 (Modified) replaces FT0165 Turbo Fixture

Engine Tools

**FT3191 Driver Socket**

Model: 770/772, D8 and 374/390

Warranty: None

Specifications	
Length	84.14 mm (3.31 in)



**9S-6343 Fixture Assembly and Turbine Holders**

- Used to disassemble turbocharger rotating assemblies by positioning turbine wheel in 9S-6343 Fixture Assembly for removal of shaft nut
- Contains sockets required to hold Schwitzer turbine wheels
- Set of 4 turbine holders available to hold AiResearch turbine wheels
- Frame of fixture retains holder in place

Item	Description
2	Turbine Holders (not serviced)

Item	Part Number	Description
1	9S-6343	Fixture Assembly <sup>1</sup>



<sup>1</sup>9S-6343 replaces FT0622

## 370-4653 C7.1 Turbocharger Alignment Tool

Model Usage: Perkins C7.1 Engines

Warranty: 6 Months

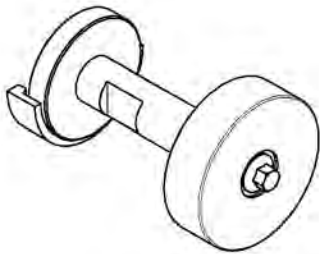

- Used to counterbalance the turbocharger for easier installation and alignment
- Used in assembly and removal of Turbocharger
- Material: Steel

Part Number	Description	Size	Weight
370-4653	C7.1 Turbocharger Alignment Tool	Counter balance: 80 mm dia. x 175 mm long	3.13 kg (6.9 lbs.)

## 9S-6363 Turbocharger Fixture Group



- Used for disassembly and assembly of current and non-current turbochargers
- Mounting plate tilts 90° so turbochargers can be positioned vertically or horizontally
- In either position, mounting plate can be rotated to 8 fixed positions in 360°

Part Number	Description
9S-6363	Turbocharger Fixture Group <sup>1</sup>

<sup>1</sup>9S-6363 replaces FT0621

## FT0175 Ring Expander Sleeve

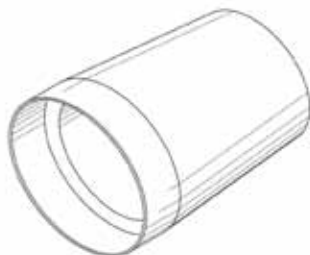

- Used to service turbocharger (see chart)

## FT0170 Support Screw

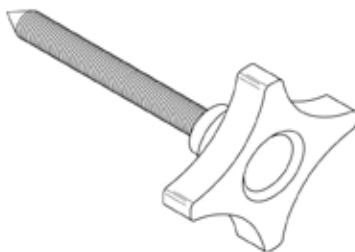

- Used to service turbocharger (see chart)

**FT0165 Modified Fixture**

- Existing FT0165 Fixture can be modified according to boxed dimensions so that only one adapter is needed for disassembly and assembly of all turbochargers
- Material: SAE 1020 steel

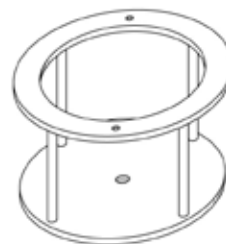
**FT0168 Fixture Adapter**

- Used to service turbocharger (see chart)
- Material: SAE 1020 steel

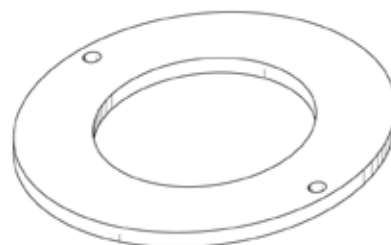
**FT0174 Driver Tool**

- Used to service turbocharger (see chart)
- Material: SAE 4140 steel

**FT0808 Fixture Adapter**

- Used to service turbocharger (see chart)
- Material: SAE 1018 steel

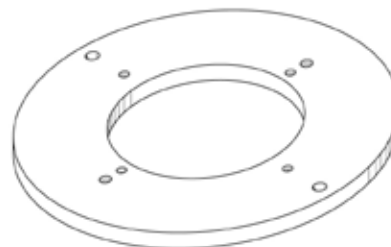

## FT1354 Turbocharger Fixture Adapter

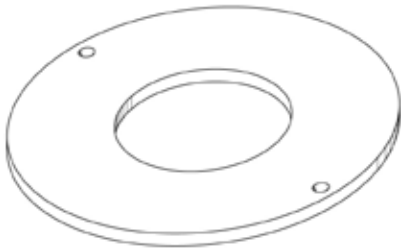

- Used with FT0165 Fixture for disassembly of AiResearch TV81 and TW81 Turbochargers
- Material: SAE 1020 steel

## FT0626 Spacer Block

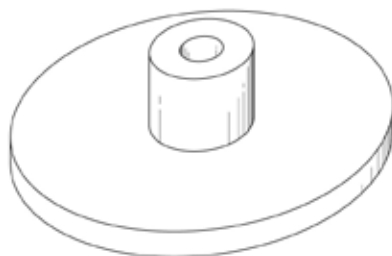

- Used to service turbocharger (see chart)
- Material: SAE 1020 steel

## FT0623 Insert Removal Tool

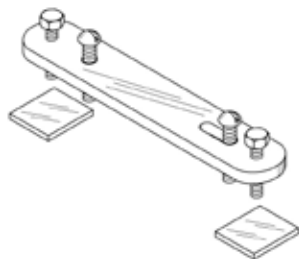

- Used to service turbocharger (see chart)
- Material: mild steel (bar) brass or aluminum (bearing plate)

## 1U-5429 Snap Ring Pliers

Model: Multiple Engine Models  
Warranty: Six Months



- Used to remove snap rings from deep bores in turbocharger housings and other components
- Plier tips slightly off center to improve visibility
- Pins made from 1.04 mm (0.041 in) diameter piano wire

Part Number	Description
1U-5429	Snap Ring Pliers

### 304-9575 Bellows Tool Assembly

#### Essential Tool

C175-16 Generator Set Engine

Warranty: Six Months

- Used to remove and install turbocharger exhaust bellows
- Fits over bellows to maintain proper shape and help prevent deforming of inlet and outlet
- Covers and protects bellows during disassembly and assembly
- Two-piece design with hinge and latch allow quick installation and removal
- 306-7948 Inner Ring Segments (four per tool) and 2N-2658 Socket Head Screw (16 per tool) are serviced separately
- Service/Repair Part: 306-7648 Ring



#### Reference

REN7466, Service Manual, C175-16 Generator Set Engine, Disassembly and Assembly

Part Number	Description
304-9575	Bellows Tool Assembly

### 304-9576 Feeler Gauge Assembly

#### Essential Tool

Model: C175-16 Generator Set Engine

Warranty: Six Months

- Used to ensure corrugations in exhaust manifold bellows are properly aligned
- Bellows corrugations must be checked when exhaust manifold is installed on engine and turbocharger
- Properly shaped and aligned corrugations will extend bellows service life
- Heavy-duty, spring-steel feeler gauge with steel handle is shaped to reach all sides of bellows
- Tool is black oxide coated to prevent corrosion



#### Reference

REN7466, C175-16 Generator Set Engine, Disassembly and Assembly

Part Number	Description
304-9576	Feeler Gauge Assembly

## 361-5661 Exhaust Bellows Remove and Install Tool

Model Usage: C9.3, C13, C15, C18, C27, and C32 Tier4 interim and Tier4 final machines

Warranty: Six Months

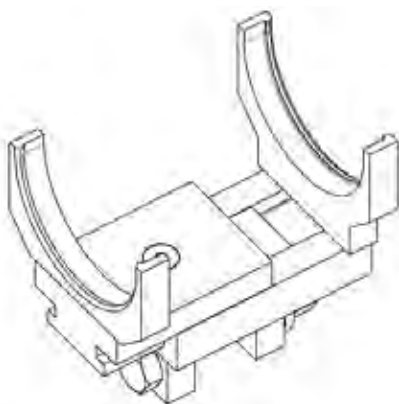

- Used to safely compress exhaust bellows for removal and installation
- Facilitates removal of bellows without removing components on either side
- Not to be used directly on bellows convolutions
- Used with 19 mm box end or ratcheting box end wrench for quick assembly

Specifications	
Dimensions	83 x 83 x 112 mm (3.3 x 3.3 x 4.4 in)
Weight	1.41 kg (3.1 lb)

Part Number	Description
361-5661	Exhaust Bellows Remove and Install Tool

## 215-2592 Wastegate Tool Kit

Model: C-15 Engine

Warranty: Six Months



- Used to test and adjust wastegate setting

Item	Description
3	Hose, 6.35 mm (0.25 in) inside diameter (not included)

Item	Part Number	Description
--	215-2592	Wastegate Tool Kit
Service/Repair Parts		
1	213-4269	Adapter
2	8C-3996	Setscrew
4	214-0788	Regulator

Item	Part Number	Description
Service/Repair Parts (Continued)		
5	215-2648	Toggle Valve
6	215-2649	Connector
7	7B-0192	Cross Fitting
8	214-0787	Pressure Gauge

## 261-0940 Bendix Air Compressor Test Kit

### Essential Tool

Model: All Cat® Truck Engines with Bendix Air Compressor

Warranty: None - Considered a Consumable



- Allows technician to accurately troubleshoot online air system on engine with Bendix Air Compressor

Part Number	Description
261-0940	Bendix Air Compressor Test Kit

### Fabricated Tools for Installing Turbine Shaft Seal Rings in Turbochargers

Model: Multiple Engine Models

Warranty: None

- Special tools designed to assist serviceman when installing shaft seal rings in turbochargers
- Eliminate possibility of ring damage resulting from overexpansion



Part Number	Description	Turbocharger Model
FT1785	Installer	T12, 61, 81
FT1786	Installer	T51
FT1787	Installer	T18
FT1788	Installer	T91
FT1789	Installer	4LE, LF, MF
FT1790	Installer	4 MD, HD, HF, ME, 5MF

### 180-5286 Turbine Shaft TPS57 Turbocharger Socket

#### Essential Tool

Model: G3606 and G3612 Engines

Warranty: Six Months

Part Number	Description
180-5286	Turbine Shaft TPS57 Turbocharger Socket

- Used to remove and install turbocharger shaft bearings
- Used with FT2685 Mounting Plate
- Socket threads onto shaft and pulls or pushes bearing
- Heat-treated for added durability
- Thread: M24 x 2
- Square drive: 1/2 inch



#### Reference

REHS0556, Special Instruction, Disassembly and Assembly of the Water Cooled TPS57 Turbocharger

### 370-4653 Turbocharger Counterbalance Tool

Model Usage: C7.1

Warranty: Six Months

- Aids in re-assembly of C7.1 turbocharger
- Ensures the turbochargers are correctly positioned.

Specifications	
Dimensions	175 x 80 x 80 mm (6.9 x 3.1 x 3.1 in)
Weight	3.14 kg (6.9 lb)

Part Number	Index Description
370-4653	Turbocharger Counterbalance Tool

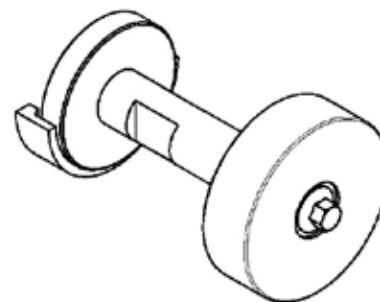

## 375-2606 Twin Turbocharger Alignment Tool

Model Usage: C4.4

Warranty: Six Months

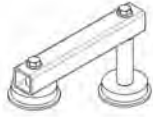

- Used to correctly align turbochargers for the bellows assembly

Part Number	Description	Dimensions	Weight
375-2606	Twin Turbocharger Alignment Tool	275 x 158 x 80 mm (10.8 x 6.2 x 3.1 in)	2.75 kg (6.1 lb)

## 365-8434 Twin Turbocharger Alignment Tool

Model Usage: C7.1

Warranty: Six Months

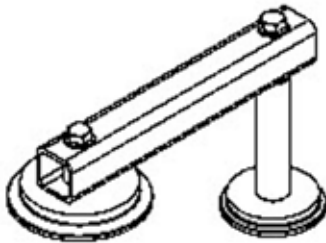

- Used to correctly align turbochargers for bellows assembly

Specifications	
Dimensions	300 x 177 x 90 mm (11.8 x 7.0 x 3.5 in)
Weight	3.27 kg (7.2 lb)

Part Number	Description
365-8434	Twin Turbocharger Alignment Tool

## Exhaust Manifold Alignment Pins

Model Usage: C7.1, C6.6, C4.4

Warranty: Six Months



366-1819



366-1820

- Used to align exhaust manifold and gaskets to cylinder head

Part Number	Dimensions	Weight
Specifications		
366-1819	63 x 11.8 mm (2.48 x .46 in)	.039 kg (0.086 lb)
366-1820	63 x 13.8 mm (2.48 x .54 in)	.051 kg (0.112 lb)

## FT2299 Turbine Holder

Model: Multiple Engine Models

Warranty: None



- Used for disassembly and assembly of turbocharger on 621E and 627E Scrapers
- Convenient tool for holding turbine wheel during removal and installation of impeller nut

### References

621E, Service Manual

627E, Service Manual



**FT2229 Puller Plate**

Model: 3406B

Warranty: None

- Required to remove impeller from water pump shaft on 3406B Engines (8S-2264 Puller Group, used to pull water pump impellers on 3406 Engines, cannot be used for this task on 3406B)
- Designed to fit narrower bolt hole spacing on 3406B impellers

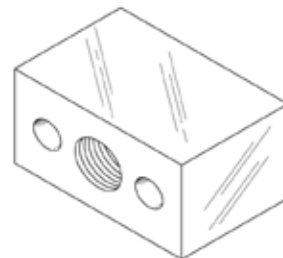

Engine Tools

**FT2800 Puller Plate**

Model: 3524B Engine in 797 Off-Highway Truck

Warranty: None

- Used to remove impeller from 199-5590 Water Pump
- Used with 1P-0820 Hydraulic Puller Group
- Material: SAE 1020 steel

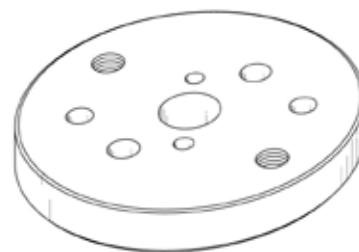
**FT2685 Turbocharger Cartridge (TPS57)****Mounting Plate Assembly**

Model: G3606 and G3612 Engines

Warranty: None

- Used to hold ABB TPS57 turbocharger cartridge for disassembly and assembly
- Used with 180-5286 Socket for maintenance of turbine bearing
- Permits one-man operation while applying sockets to each end of turbine shaft

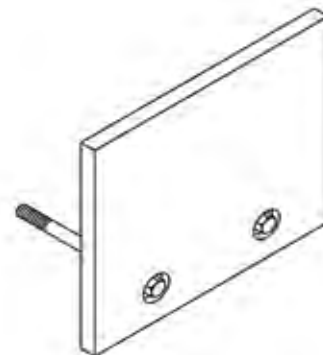

## 319-2189 Diesel Particulate Filter Ash Cleaning Tool

Model: Cat® Engines

Warranty: Six Months

Engine Tools



- Cleaning process (patent pending) that utilizes pulsed air
- Fully automated computer-controlled process
- Pre-clean DPF check to verify that DPF can be cleaned
- Cleans all Cat® DPF sizes
- Self-cleaning feature to extend the cartridge filter life
- Full containment of ash for safe and easy disposal

### Reference

NEHS1034, 319-2189 DPF Cleaner Tool Operating Manual

### Cleaning Process

1. Perform an Ash Service Regeneration
2. Remove the DPF from the vehicle and place it in the cleaning tool
3. Start the cleaning tool using the Cat® cleaning cycle
4. Re-install filter on the vehicle
5. Cat® ET needs to be used to program the Engine ECM that an Ash Cleaning has been performed

### Cleaning Methods

This tool and process is the preferred and most economical method for cleaning of DPF's.

### More Information

A brief video walk around and the Tech Tips video segment are available at <https://truck.cat.com/cda/layout?m=121186&x=7>

### Compatibility

The base Cat® DPF Cleaning Tool could be used with the proper adapters for (Cummins, Mack, Volvo, Hino and others) to clean their DPF's. This flexibility will allow customers and TEPS dealers to purchase just one base tool. OEM specific adapters and software must be purchased through the engine manufacturer.

Specifications	
Dimensions (L x W x H)	1900 x 1010 x 2100 mm (75 x 40 x 83 in)
Weight	500kg (1100 lb)
Power	110 VAC / 60Hz
Air	875 kPa (125 psi) recommended
	700 kPa (105 psi) minimum

Part Number	Description
319-2189	DPF Cleaner Group
319-2190	DPF Cleaner Adapter Group
<b>319-2189 DPF Cleaner Group Contains: Base Tool, DPF Cleaner Software, Base Tool DPF Cleaner (no adapters) and the following:<sup>1</sup></b>	
319-2190	DPF Cleaner Adapter Group
<b>319-2190 DPF Cleaner Adapter Group Contains the following:<sup>1</sup></b>	
319-1834	Cone, 27.94 cm (11 in)
319-1835	Cone, 33.02 cm (13 in)
319-1836	Cone, 38.10 cm (15 in)
319-1838	Adapter (Lower), Large
319-1839	Adapter (Lower), Small

Part Number	Description
<b>Optional Accessories include NETG5056 DPF Cleaner Software and the following:</b>	
373-2992	CT660 DPF Adapter Ring
373-9826	Tier 4 DPF Adapter Ring (pin and slot design)
319-2192	Mass Transit Bus Adapter <sup>2</sup>
<b>Consumables</b>	
319-2193	HEPA Filter
319-2194	Cartridge Filters (contains 2 filters)
319-1833	Filter Bucket
320-2679	Air Dryer Desiccant
320-2680	Coalescing Filter

<sup>1</sup> NETG5056 will be required if 319-2189 DPF Cleaner Group is not purchased.

<sup>2</sup> Use with the 319-1835 Cone

### Differential Pressure Regulator Testing and Reconditioning Apparatus

Model: Multiple Engine Models

Warranty: Six Months

- Required to test and calibrate differential pressure regulators
- Basic test apparatus required for fuel operated pressure ratio controls and exhaust bypass valves
- Additional parts required for pneumatic pressure ratio control

#### References

FE035027, Special Instructions

FE034610, Special Instructions

Non-Part Number Items (in photo)	
Item	Description
1	Basic Apparatus
6	Calibration Plate
7	Rod



Item	Part Number	Description
2	4L-9555	Cover
3	3B-7722	Bushing-Pipe-Reducing 3/8 in-18 NPTF to 1/4 in-18 NPTF
4	3B-7276	Nipple
5	5L-3252	Cover
8	9M-0428	Gauge (or Manometer)
9	3B-7263	Nipple - Pipe
10	3B-7719	Coupling

### 6V-7060 Gauge Group

Model: Multiple Engine Models

Warranty: Six Months

- Used to measure seal ring grooves on turbocharger components
- Precision ground to maximum permissible width for seal ring grooves on turbine shaft and when assemblies, flinger sleeves and thrust collars
- Gauge held perpendicular to groove when measurements made; if gauge will enter groove, part must be reconditioned or scrapped; if gauge will not enter, part is reusable

Part Number	Description	Size
6V-7012	Foam Insert	--
6V-7016	Gauge	3.302 mm (0.1300 in)
6V-7017	Gauge	2.591 mm (0.1020 in)
6V-7018	Gauge	1.765 mm (0.0695 in)
6V-7019	Gauge	1.740 mm (0.0685 in)



(Continued)

## 6V-7060 Gauge Group (Continued)

Model: Multiple Engine Models

Warranty: Six Months

Part Number	Description	Size
6V-7021	Gauge	1.689 mm (0.0665 in)
6V-7022	Gauge	1.676 mm (0.0600 in)
6V-7023	Gauge	1.659 mm (0.0653 in)
6V-7060	Gauge Group	--
6V-6045	Case - Plastic, NEEG2061 Accessories Case Decal	--

## FT1781 Cartridge Checking Fixture

Model: Multiple Engine Models

Warranty: None



- Used to check reconditioned cartridge assemblies in turbocharger for correct end play movement
- Increases service life by early detection of end play movement not within correct tolerances (end clearance problems can result in turbocharger failure, which could result in engine failure)

## FT1782 Turbocharger Test Stand

Model: Multiple Engine Models

Warranty: None



- Used to test all current turbochargers that are used on Caterpillar® engines
- Used to test seal ring leakage, end housing clearance and shaft rotation
- Can also give break-in before installation — uses air and oil pressure to provide conditions that are similar to normal operation
- Has oil heater to raise temperature of oil to normal engine oil temperature

### 2P-2333 High Temperature Sealer

Warranty: Six Months

Model: Multiple Engine Models

- Used on all exhaust manifold joints, either flat or cylindrical
- Retains sealing characteristics at temperatures up to 980° C (2000° F)

Part Number	Description
2P-2333	High Temperature Sealer



### 143-9730 Wrench (30 mm throat)

### 143-9731 Wrench (122 mm throat)

Model: 3176, 3176B, C-10, C-12, 3114, 3116, 3126 Engines

Warranty: Six Months

- Used to properly tighten hard-to-reach 15 mm (0.59 in) nuts
- Used with 1/2 inch square drive torque wrench
- Helps prevent turbocharger gasket failures
- 2 wrenches fit almost all turbocharger installations

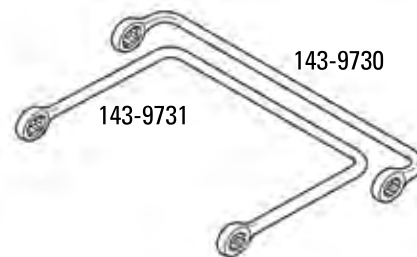

Part Number	Description	Size	Drive	Distance Between Wrench Faces
143-9730	Turbocharger Wrench, 30 mm (1.18 in) reach throat	15 mm, 12 point	12 in, square	266.7 mm (10.50 in)
143-9731	Turbocharger Wrench, 122 mm (4.8 in) reach throat	15 mm, 12 point	12 in, square	200 mm (7.87 in)

### 329-5928 Slotted Socket

#### Essential Tool

Model: C-7 and C-9 Turbochargers

Warranty: Six Months

Part Number	Description
329-5928	Slotted Socket

- Used to remove and install speed sensor on turbocharger
- Used with 3/8 inch square drive wrench
- Cut out deep-well design provides clearance for speed sensor
- 5-point hex (13 mm) design helps prevent sensor damage

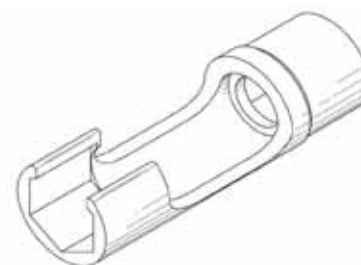

## 349-3548 Slotted Socket

### Essential Tool

Model: All Tier 4 Engines

Warranty: Six Months

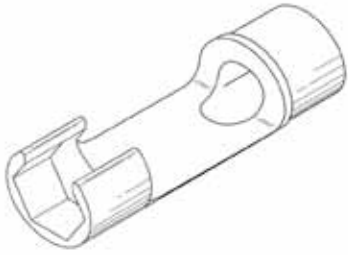

- Used to remove and install flame detect sensor on Cat® Tier 4 Engines with Caterpillar® Regeneration System (CRS) heads
- Used with 3/8 inch square drive wrench
- Cut out, deep-well design provides clearance for sensor connector
- Five point hex (16 mm) design helps prevent sensor damage
- Socket is 78 mm (3.0 in) long with a durable chrome plated finish

Part Number	Description
349-3548	Slotted Socket

## 342-9516 Slotted Socket

### Essential Tool

Model: 330E Excavators

Warranty: Six Months

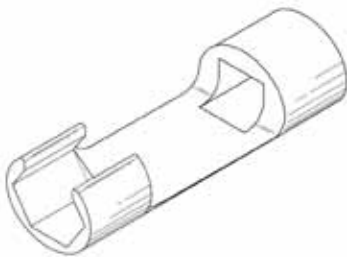

- Used to remove and install 320-0576 Engine Temperature Sensor
- Used with 3/8 inch square drive wrench
- 17 mm deep-well socket with cut out provides clearance for sensor body
- Five-point hex grips sensor base helping prevent damage to sensor
- Chrome plated for corrosion resistance
- Length: 78 mm (3.07 in)

Part Number	Description
342-9516	Slotted Socket

## Cooling System

**FT2554 Holding Fixture**

Model: 793C Trucks

Warranty: None

- Used to provide safe method for holding radiator and cowling group during removal and installation of modular front end
- Prevents bottom of radiator tank from being crushed
- Allows use of fork lift, with a 2722 kg (6000 lb) capacity, to move radiator and cowling group once removed from truck
- Overall length x width: 3048 x 3101 mm (120 x 122 in)

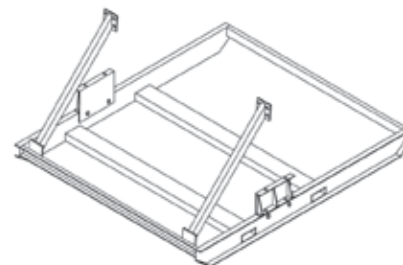
**348-4227 Holding Fixture Assembly**

Model: 793D Mechanical Drive Off-Highway Truck

Warranty: Six Months

- Replaces canceled FT3044 Holding Fixture Assembly
- Used to provide secure method for holding and storing radiator and cowling group during removal and installation of modular front end
- Prevents bottom of radiator tank from being crushed when removed from truck
- Allows use of fork lift with a 2722 kg (6000 lb) capacity, to move or store radiator and cowling group once removed from truck
- Overall size (L x W x H): 305 x 229 x 236 cm (120 x 90 x 93 in)

**Reference**

REN8334, 793 Off-Highway Truck Disassembly and Assembly Engine Supplement, Modular Front End Remove and Install

Part Number	Description
348-4227	Holding Fixture Assembly

**315-0009 Tool Group****Essential Tool**

Model: 793D and 793F MD Off-Highway Truck

Warranty: Six Months

**Reference**

REN8334, 793D Off-Highway Truck Engine Supplement, Disassembly and Assembly, Modular Front End Remove and Install

- Used to hold radiator, with shrouding and ladder, in vertical position
- Used with 175-7532 Radiator Support Assembly
- Consists of 315-0227 Left-Hand Fixture Assembly, 316-0649 Right-Hand Fixture Assembly, and mounting hardware, all serviced separately
- Prevents damage to bottom of radiator when removed from truck
- Requires a minimum 2722 kg (6000 lb) forklift to move fixture and radiator combination
- Fixture assemblies have 3E-3879 Eyebolt (M16 x 2) to allow easy lifting and positioning (part of assembly)
- Uses 4K-7239 Dowels to locate fixture assemblies on radiator support assembly (part of assembly)

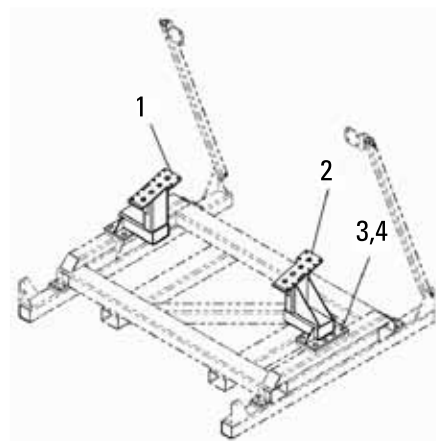

Item	Part Number	Description	Quantity
--	315-0009	Tool Group	--
1	315-0227	Left-Hand Fixture Assembly	1
2	316-0649	Right-Hand Fixture Assembly	1

(Continued)

# Cooling System

## 315-0009 Tool Group (Continued)

### Essential Tool

Model: 793D and 793F MD Off-Highway Truck

Warranty: Six Months

Item	Part Number	Description	Quantity
3	8T-0666	Bolt, M24 x 76.2 mm (3.0 in) long	--
4	6V-8237	Hard Washer	--

Engine Tools

## 178-3704 Lift Bracket Assembly

### Essential Tool

Model: Multiple Machine Models

Warranty: Six Months



- Used to remove AMOCs radiator cores on 950 through 994 Wheel Loaders, all Wheel Tractors, and any vehicle using AMOC Radiator Cores
- Allows one-person removal and installation of radiator cores
- To install: place bale in "down position" and attach bracket over top of radiator core with center hole over core protrusion to restrict side movement
- To lift: push bracket down to properly position spring-loaded wings and raise bale to "up position"; tighten set screws to positive lock
- To remove: place radiator core on ground (remove weight) and place bale in down position

Part Number	Description	Lift Capacity
178-3704	Lift Bracket Assembly	45.4 kg (100 lb)

## 208-1350 Radiator Fin Comb

Model: Multiple Engine Models

Warranty: Six Months



- Multi-head tool which handles 8, 9, 10, 12, 14, and 15 fins/inch
- Breaks down easily for tool box storage

Part Number	Description
208-1350	Radiator Fin Comb

## 307-6728 Air Wand

### 240-9588 Twist-lock Coupler

Model: D8T and D9T Track Type Tractors

Warranty: Manufacturer's

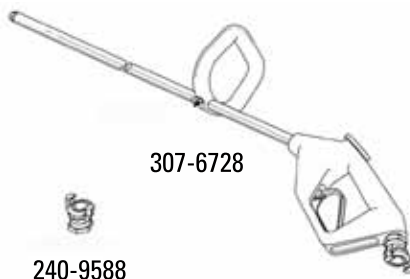

- Used to clean radiator cores and cooling components
- Supplied with 3/4 inch twist lock coupler (240-9588 Twist Lock Coupler, sold separately, mates with air wand coupler)
- Aluminum extension tube is 179 cm (70.5 in) long for cleaning hard to reach areas
- Adjustable handle on extension tube adds stability during cleaning operations
- Twenty-two 3 mm (0.12 in) holes at end of extension tube provide more efficient cleaning
- Air wand provides up to 4 kp (9.0 lbf) thrust at 690 kPa (100 psi) and 5700 lpm (200 scfm) air flow

(Continued)



## 307-6728 Air Wand (Continued)

### 240-9588 Twist-lock Coupler

Model: D8T and D9T Track Type Tractors

Warranty: Manufacturer's

- Lightweight design for easy use
- Compliant with OSHA standards
- Rebuild kits are available (see charts)

Part Number	Description
307-6728	Air Wand (with twist-lock coupler)
240-9588	Twist-lock Coupler (for air supply hose)

### 317-6934 Trigger Kit

Part Number	Description
317-6934	Trigger Kit

Item	Description
1	Replacement Trigger
2	Pin
3	Warning Film

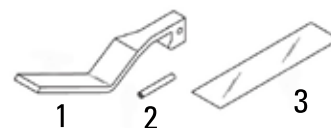

### 317-6935 Extension Kit

Part Number	Description
317-6935	Extension Kit <sup>1</sup>

Item	Description
1	Replacement Extension Tube, 1791 mm (70.5 in)
2	Extension Cap
3	Pin
4	Warning Film

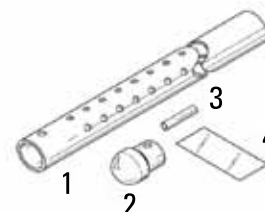

<sup>1</sup>Used with 317-6937 Compression Fitting

### 317-6936 Handle Kit

Part Number	Description
317-6936	Handle Kit

Item	Description
1	Replacement Handle
2	Handle Clamp (2)
3	Bushing
4	Bolt
5	Bolt
6	Nut (2)
7	Washer (2)

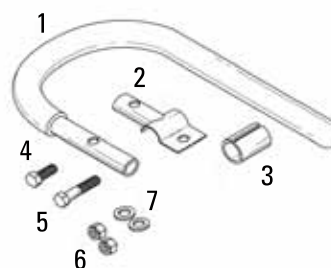

### 317-6937 Compression Fitting

Item	Description
1	Compression Fitting
2	Compression Ring
3	Compression Nut

Part Number	Description
317-6937	Compression Fitting <sup>1</sup>



<sup>1</sup>Used with 317-6935 Extension Kit

## 317-6938 Valve Rebuild Kit

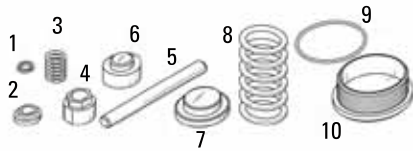

Item	Description
1	O-ring
2	Top Packing
3	Spring
4	Packing Nut
5	Valve Stem
6	Poppet Skirt
7	Poppet Seal
8	Spring
9	O-ring
10	Valve Cap

Part Number	Description
317-6938	Valve Rebuild Kit

Engine Tools

## FT2978 Nozzle

Model: Most Models

Warranty: None

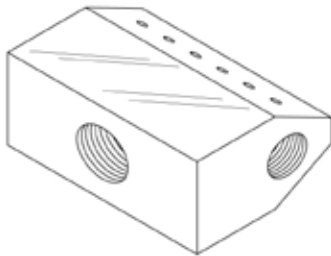

- Used to clean hard to reach places between radiator core and other cooling components
- Used with 156-0931 Air Gun

## FT1377 Installer

Model: Multiple Engine Models

Warranty: None



- Used when installing side channels on radiator cores on D10 Tractors
- Compresses resilient strips so that bolts and holes can be aligned

## 2S-9528 Blade Reversing Tool

Model: Multiple Engine Models

Warranty: Six Months

Part Number	Description
2S-9528	Blade Reversing Tool

- Used to change fan blade pitch on machines equipped with reversible fan blades



## Tooling for Variable Speed Fan Clutch on Trucks

Model: Multiple Engine Models

Warranty: None

- Provides tooling needed to disassemble and assemble variable speed fan clutch on 768C, 769C, 771C, 772B, 773B, 775B, 784B, 785B, 789B, and 793B Trucks
- FT2461 and FT2467 used to disassemble and assemble 6I-4427 and 123-6968 Fan Clutches
- FT2464 and FT2465 Plates used to disassemble and assemble 100-8105 and 129-9494 Fan Clutches which are both replaced by 133-5969 Fan Clutch

### Reference

SEN8603-01, Variable Speed Fan Clutch

Item	Part No.	Description	Material
1	FT2461	Pressing Bar	SAE 4140 steel
2	FT2462	Pressing Tube	SAE 4140 steel
3	FT2463	Ring	SAE 4140 steel
4	FT2464	Plate	SAE 4140 steel
5	FT2465	Plate	SAE 4140 steel
6	FT2466	Mounting Plate	SAE 4140 steel
7	FT2467	Rotating Plate	

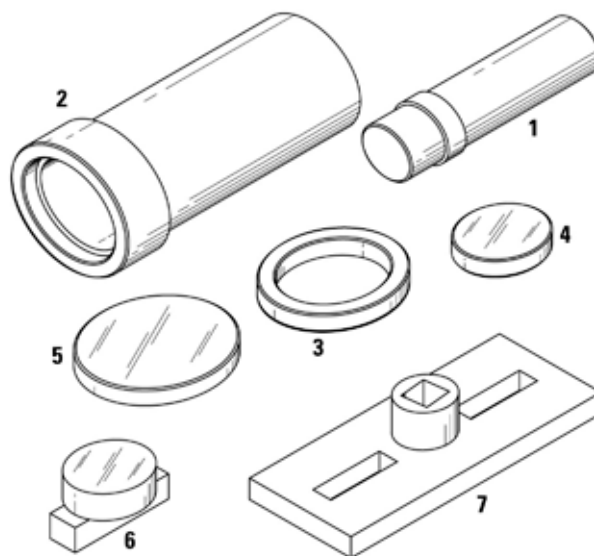

## Disassembly and Assembly Tooling for 200 Rockford Fan Clutch

Model: Multiple Engine Models

Warranty: None

- Used to disassemble and assemble 183-5116 (200 Series Rockford) Variable Speed Fan Clutch on D9R (s/n ABK and ACL) and D10R (s/n 3KR and AKT) Track-Type Tractors
- Heat treat FT2814 through FT2820 to RC 38 to 42

### Reference

SEN8603-01, Variable Speed Fan Clutch

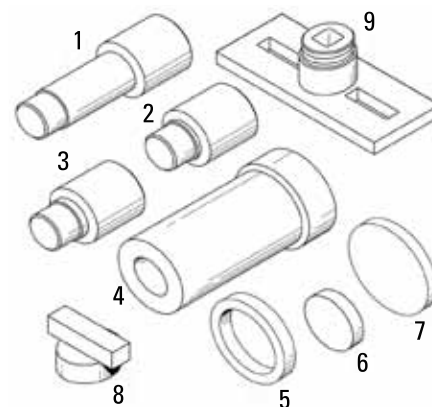

(Continued)

## Disassembly and Assembly Tooling for 200 Rockford Fan Clutch (Continued)

Model: Multiple Engine Models

Warranty: None

Item	Part Number	Description	Material
1	FT2814	Bearing Remover	SAE 4140 steel
2	FT2815	Bearing Installer	SAE 4140 steel
3	FT2816	Bearing Installer	SAE 4140 steel
4	FT2817	Bearing Remover	SAE 4140 steel
5	FT2818	Installation Ring Plate	SAE 4140 steel
6	FT2819	Fan Hub and Shaft Assembly Removal Plate	SAE 4140 steel
7	FT2820	Bearing and Seal Removal and Installation Plate	SAE 4140 steel
8	FT2821	Clutch Body Hold Fixture Assembly	SAE 1020 steel
9	FT2822	Fan Mounting Hub Removal and Installation Fixture Assembly	SAE 1020 steel

## Tooling for Variable Speed Fan Clutch on Off-Highway Trucks

Model: Multiple Engine Models

Warranty: None

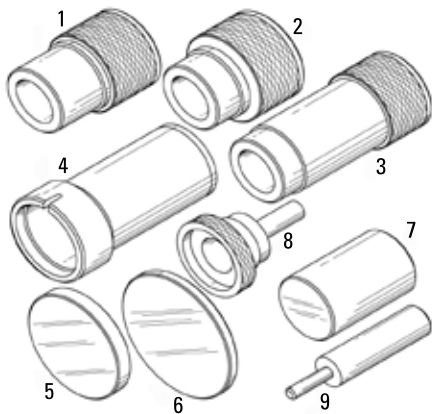

- Used to disassemble and assemble variable speed fan clutch on 784C, 785C, 785CHAA, 789C, and 793C Off-Highway Trucks
- Ensures proper positioning and installation of clutch parts
- Material (all parts): SAE 4140 steel

### Reference

REN2634, Service Manual, Variable Speed Fan Clutch

Item	Part Number	Description
1	FT2749	Bearing Installer
2	FT2750	Bearing Installer
3	FT2751	Bearing Remover
4	FT2752	Seal Installer Assembly
5	FT2753	Bearing Installer
6	FT2754	Bearing Installer
7	FT2755	End Cap Remover
8	FT2756	Sensor Installer
9	FT2757	Sensor Installer

### FT0203 Spring Compressor

Model: Multiple Engine Models

Warranty: None

- Water temperature regulators can be disassembled by fabricating a short length of pipe as illustrated

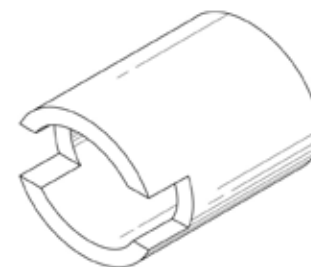

### FT0161 Thermometer Adapter

Model: D8H Engine

Warranty: None

- Used to mount the Thermometer to D8H Engine

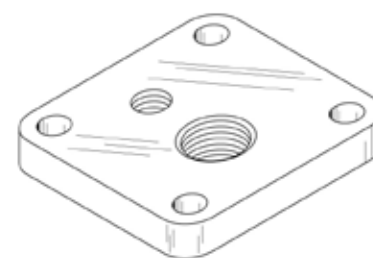

### 243-6532 Spanner Wrench Assembly

Model: C-9 Engines in Timber King Feller Buncher

Warranty: Six Months

Part Number	Description
243-6532	Spanner Wrench Assembly

- Used to disassemble and assemble Flexxaire engine fans
- Used with 1/2 inch square drive ratchet

Square drive	1/2 in
Number of teeth	4, equally spaced
Tooth width	6.1 mm (0.24 in)
Inside diameter	64.0 mm (2.5 in)
Outside diameter	76.2 mm (3 in)

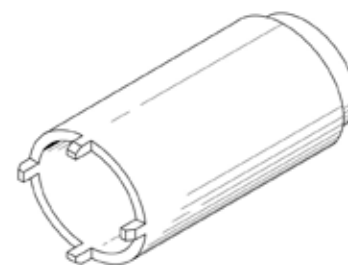

## 9S-8140 Pressurizing Pump

Model: Multiple Engine Models

Warranty: Six Months



- Used to pressurize cooling systems to detect leaks
- Can also test dash gauges, relief valves, and pressure caps
- All items in figure are included

### Reference

SMHS8303, Special Instruction

Item	Part Number	Description
--	9S-8140	Pressurizing Pump
<b>Consists of:</b>		
1	6V-7775	Gauge 0 - 205 kPa (0 - 30 psi)
2	2P-2331	Release Valve <sup>1</sup>
3	3R-3810	Hose
4	2P-2329	Adapter Bushing
5	9S-8139	Packing (Internal)
6	6V-0117	Bushing
<b>Not shown</b>		
--	4M-5317	Pipe Reducing Bushing <sup>2</sup>
--	186-5234	Hose Assembly
--	6V-9068	Valve Kit

<sup>1</sup>Not included in earlier pump groups; to permit testing of automotive-type cooling systems, ordered and installed on earlier pumps

<sup>2</sup>Part of Cylinder Pressure Group (Gas Engines)

## 259-6237 Cooling System Tester

### Essential Tool

Model: 416, 420, 428, 430, 434, 442 Series E Backhoe Loaders, Small Track-Type Tractors, Small Track-Type Loaders, Mini-Excavators, Compact Wheel Loaders

Warranty: Manufacturer's Lifetime



- Used to pressure test cooling systems that use screw-on type radiator caps
- Used on many light commercial vehicles, passenger vehicles, marine applications, and motorcycles with internal radiator neck diameters of 45.0 mm (1.77 in) or less
- Cooling system tester group includes: pump, set of extensions to fit different sizes of radiator necks, gauge, supply and drain hoses, instruction book, and carrying case

### Repair Information

SPX Service Repair

755 Eisenhower Drive

Owatonna, MN 55060

Attn: Repair Department

Phone: 800-344-4013

Visit the SPX Repair Track web link to complete and submit the form for proper authorization: <https://repairtrack.spx.com>

Part Number	Description
259-6237	Cooling System Tester

**FT0200 Seal Case Removal Tool**

Model: Multiple Engine Models

Warranty: None

- Used to remove brass case on any water pump equipped with carbon thrust washer and bellows-type seal on D9H, 776, 777, 777B
- Material: SAE 1020 steel

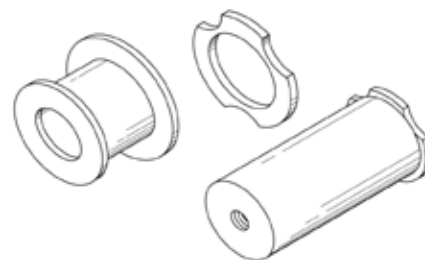
**5P-9722 Seal Driver**

Model: 3208 Engines

Warranty: Six Months

Part Number	Description
5P-9722	Seal Driver

- Used to install the 9N-3141 Water Pump Seal Assembly (9N-3075 Water Pump and 9N-3898 Water Pump)
- Required to compress seal spring pre-determined distance

**References**

SENR3910, 3176 Service Manual

SEHS9120, Special Instruction, Operation

**9U-6944 Pump Seal Installer**

Model: 3046 Diesel Engine

Warranty: Six Months

Part Number	Description
9U-6944	Pump Seal Installer

- Used to install water pump seal

**Reference**

SENR6458, Special Instruction, Disassembly and Assembly of 3046 Engines

**6V-6159 Seal Guide**

Model: 3204 Engines

Warranty: Six Months

Part Number	Description
6V-6159	Seal Guide

- Used for assembly of 1W-6446 Water Pump and 2W-1223 Water Pump
- Prevents shaft seal from rolling when shaft is installed in water pump housing



## FT1783 Fixture

Model: Multiple Engine Models  
Warranty: None

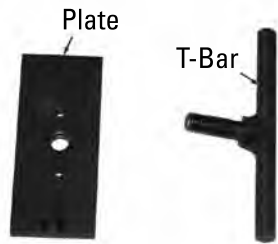

- Facilitates drilling of vent holes in water pump impellers
- Consists of locating plate and threaded T-bar (can be fabricated according to FT1783 drawings)

## Impeller Installers

Model: 3204, 3208  
Warranty: Six Months



- Used with an arbor press to position impeller to specified clearance from water pump body
- Designed to bottom on water pump body when impeller is in correct position on shaft
- 8T-3142 Impeller Installer for all 3204 Family Engine water pumps
- 8T-0457 Impeller Installer for all 3208 Family Engine water pumps

Part Number	Description
8T-3142	Impeller Installer - 3204 Family Engine water pumps
8T-0457	Impeller Installer - 3208 Family Engine water pumps

## Fabricated Tools for Reconditioning and Testing 3400 Series Engine Water Pumps

Model: 3400  
Warranty: None



Item	Part Number	Description	Use
1	FT1760	Driver	Used with hammer to drive shaft from pump assembly
2	FT1762	Test Driver	Used with V1-A Vacuum Tester to test water seal after assembly



## Fabricated Tools for Reconditioning and Testing 3208 Engine Water Pumps

### Group 1

Model: 3208

Warranty: None

Group 1			
Item	Part Number	Description	Use
1	FT1700	Fixture	Used to hold water pump shaft during pump assembly
2	FT1706	Installer	Used with arbor press to install bearings into housing
3	FT1705	Installer	Used with arbor press to install seal into housing
4	FT1704	Installer	Used with arbor press to install impeller on shaft
5	FT1752	Test Fixture	Used with V1-A Vacuum Tester to test water seal after assembly



## Fabricated Tools

### Group 2

Group 2			
Item	Part Number	Description	Use
6	FT1708	Fixture	Used with FT1707 Ram Adapter and hydraulic press to remove impeller and seal from shaft
7	FT1707	Ram Adapter	Used with FT1708 Fixture and hydraulic press to remove impeller and seal from shaft
8	FT1702	Driver	Used with hammer to drive rear bearing from pump housing
9	FT1703	Driver	Used with hammer to drive front bearing from pump housing
10	FT1701	Fixture	Used to hold pump housing during disassembly



## FT1733 Fixture



Item	Part Number	Description	Use
11	FT1733	Fixture	Used with Zero automated glass bead machine to clean pump housings, pulleys and impellers

## FT1732 Salvage Fixture



Item	Part Number	Description	Use
12	FT1732	Salvage Fixture	Used with 6.74 mm (17/64 in) drill and drill press to drill holes in pump housing flanges that have been rebuilt with weld

## Water Pump Seal Installation Tools

Model: Multiple Engine Models

Warranty: Six Months



- Water pump seal installation tool has been removed from 4W-3864 Water Pump Seal Groups
- 7N-7843 and 7N-8268 Water Pump Seal Installation Tools used to install seal groups in respective water pumps (see chart)

### Reference

SEHS8449, Special Instruction

Part Number	Description	Engine
4W-3864	Water Pump Seal Group	3300 Series and 3406B
7N-7843	Installation Tool	3400 Series
7N-8268	Installation Tool	6 1/4 Bore Vee

## 172-5711 Seal Installer

Model: 3306 Engines

Warranty: Six Months

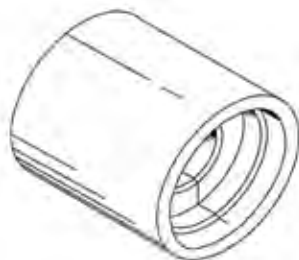

- Used to install 154-9291 and 169-1750 Water Pump Seals
- Makes installation quick and easy

Part Number	Description	Outside Diameter	Inside Diameter	Counter Bore Diameter	Material
172-5711	Seal Installer	47.4 mm (1.87 in)	19.54 mm (0.769 in)	36.50 mm (1.437 in)	Steel

## 248-3310 Spanner Wrench

## 248-3311 Holding Fixture

Model: G3520B and G3520C Engines in Large Mining Trucks

Warranty: Six Months

Part Number	Description
248-3310	Spanner Wrench
248-3311	Holding Fixture

- Used to disassemble and assemble jacket water (JW) pumps and separate circuit aftercooler (SCAC) water pumps
- Used with a bench vise and 1/2 inch square drive ratchet
- Special repair tools allow pump repair instead of pump replacement
- Holding fixture is placed in a bench vise to hold pump spline
- Spanner wrench fits innermost locknut inside pump housing

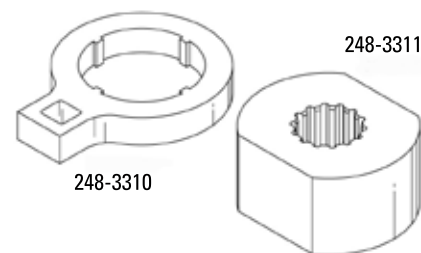

## 193-8094 Spline Wrench (14 Teeth)

## 193-8100 Impeller Nut Spanner

Model: All 3500 Marine Engines with discontinued 148-8000 Seawater Pump

Warranty: Six Months

Part Number	Description
193-8094	Spline Wrench (14 Teeth)
193-8100	Impeller Nut Spanner

- Used to disassemble and assemble pump during rebuild
- 193-8094 used to hold spline
- 193-8100 used to remove locknut

### Reference

SENR6564, Service Manual, 3500B Engines Disassembly and Assembly

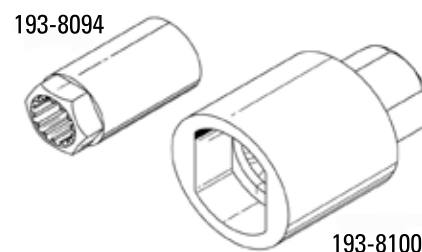

## Water Pump Seal Installers

Model: 3400 Engines

Warranty: Six Months

- Used to install water pump seals
- Both 139-0088 and 138-9299 tools work on 3406C Engines with serial numbers 8PN10279-UP and 3406E Engines with serial numbers 5EK85240-UP

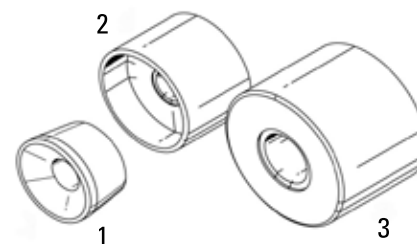

Item	Part Number	Description	Outside Diameter	Inside Diameter	Counter Bore Diameter	Material	Installs
1	138-9299	Oil Seal Tool	35.42 mm (1.394 in)	19.25 mm (0.757 in)	--	Aluminum or Plastic	Pump shaft through 136-1152 Oil Seal in pump housing <sup>1</sup>
2	139-0088	Seal Installer	43.9 mm (1.73 in)	19.31 mm (0.760 in)	37.6 mm (1.48 in)	Steel	128-0317 Coolant Seal and support ring in housing
3	147-6521	Seal/Shaft Installer	--	--	--	--	Shaft/oil seal assembly into early pump housing

<sup>1</sup>136-1152 is discontinued

## 135-7629 Water Pump Seal Installer

Model: 3406 Engines

Warranty: Six Months

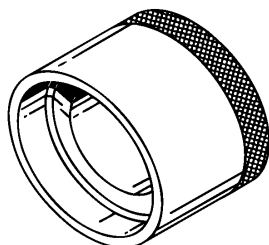

- Used to correctly and quickly install the 118-9163 Seal Group in water pumps
- Replaces discontinued 2W-9102 Installation Tool (Water Pump Seal) and 125-9622 Seal Installer (Water Pump)
- Seal fits into counterbore of seal installer
- Seal installer slips over pump shaft (seal is installed using hand force)
- Overall length: 22.4 mm (0.88 in)
- Diameter: 31.75 mm (1.25 in)

Part No.	Description
135-7629	Water Pump Seal Installer

### Reference

SEHS8449, Special Instruction, Installation of Water Pump Seal Group

## 323-3526 Seal Installer

### Essential Tool

Model: C9 Marine Engine, C9 Petroleum Engine

Warranty: Six Months



- Used to install 200-3052 Seal Group in water pump
- Seal fits into counterbore of seal installer and then uses pump shaft as a guide
- Correctly installs seal without damage
- Durable, steel construction

Part No.	Description
323-3526	Seal Installer

### Reference

REN8633, C9 Petroleum Disassembly and Assembly

## 325-5756 Seal Installer

### Essential Tool

Model: C15 and C18 Engines for Cat® Built Machines and On-Highway use

Warranty: Six Months



- Used to install 276-4756 Seal Group in water pump
- Seal fits into counterbore of seal installer and then uses pump shaft as guide
- Correctly installs seals without damage
- Durable, steel construction
- Black oxide coating for corrosion resistance

Part No.	Description
325-5756	Seal Installer

### Reference

REN9706, C15 On-Highway Engines

### 183-4028 Seal Installer

#### Essential Tool

Model: 3176, C-10, C-12, and 3196 Engines

Warranty: Six Months

Part No.	Description
183-4028	Seal Installer

- Used to install 147-5088 Pump Seal into 153-8053 Pump
- Provides quick, easy installation



### 417-6000 Seal Installer Tool, 417-6001 Seal Installer Tool

Model Usage: 3406E, C15, C18, G3516C Auxiliary Water Pump

Warranty: Six Months

- Used to correctly install new style seals into 391-2227 Sea Pump
- Guides seal and set seals to correct depth
- Black Oxide coated for durability
- Used in conjunction with hand press

#### Reference

REN2389, C18 Marine and Auxiliary Marine Generator Set Engines

Specifications		
Part Number	Description	Dimensions
417-6000	Seal Installer Tool	140 x 55.8 mm (5.5 x 2.2 in)
417-6001	Seal Installer Tool	90 x 31.7 mm (3.5 x 1.3 in)



417-6000



417-6001

### FT3201 Seal Installer

Model Usage: C15, C18, 3400 Engines

Warranty: None

- Used to install 336-2212 Pump Seal
- Correctly installs seal without damage
- Provides quick, easy installation
- Made from Mild steel

FT3201	Seal Installer
--------	----------------

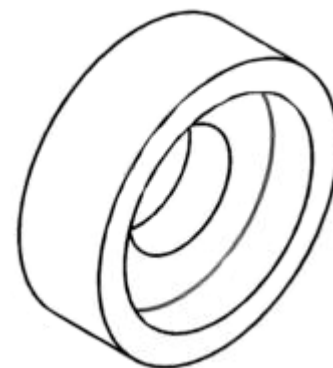

## FT3202 Seal Installer

Model Usage: C15, C18, 3400 Engines

Warranty: None

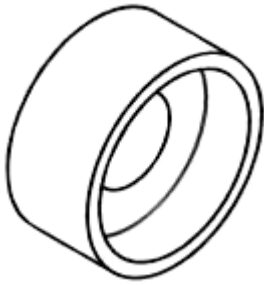

- Used to install 349-2654 Pump Seal
- Correctly installs seal without damage
- Provides quick, easy installation
- Made from Mild steel

FT3202	Seal Installer
--------	----------------

## FT3171 Seal Installer

### Essential Tool

Model: Cat® Marine Engines

Warranty: None



- Used to install 336-2212 Pump Seal in 352-8589 Pump
- Correctly installs seal without damage
- Provides quick, easy installation
- Made from SAE 1020M steel

## 1U-9582 Seal Guide

Model: 3304 and 3306 Series Engines

Warranty: Six Months



- Used in repair of water pumps on 3304 and 3306 Series Engines
- Prevents damage to 8C-5210 Seal while installing impeller shaft
- Seal installed into housing first, and shaft installed through seal

Part Number	Description
1U-9582	Seal Guide

### 9U-5103 Slotted Socket

Model: 3406E, C-15, and C-16 Engines

Warranty: Six Months

Part Number	Description
9U-5103	Slotted Socket

- Used to remove and install coolant temperature sensor
- Deep well design easily reaches sensor
- Slotted side for sensor wire clearance
- Square drive: 1/2 inch
- Socket type: 6 point, 1 1/16 in



### 9U-6627 Seal Installer, 9U-6626 Locknut Spanner Wrench

#### 2P-2317 Locknut Spanner Wrench

Model: 3400 Marine Engines

Warranty: Six Months

- Used to disassemble and assemble 6I-1928 and 105-0268 Raw Water Pumps — used on 5N-6054 Seal Group
- Spanner sockets reduce removal time of shaft locknuts — easier removal and less chance of damage
- Dual purpose 9U-6627 Seal Driver installs seal — ring is used with driver to remove old seal

Item	Part Number	Description
1 & 2	9U-6627	Seal Installer (Includes item 2 Seal Remover)
3	9U-6626	Locknut Spanner Wrench
4	2P-2317	Locknut Spanner Wrench



### 164-2192 Pressure Probe

Model: Multiple Engine Models

Warranty: Six Months

- Replaces discontinued 5P-2718 Pressure Probe
- Used with pressure gauge to check pressure of fluid-filled compartments
- Fits 3.175 mm (1/8 in) pipe plug threads
- Can be used alone or with 5P-2720 Probe Adapter Group, 5P-2725 Probe Adapter Group, or 5P-3591 Probe Adapter Group
- Can be used in applications up to 2750 kPa (400 psi)

Part Number	Description
164-2192	Pressure Probe



## 9U-6956 Water Pump Seal Installer

Model: 3408 and 3412 Marine Engines

Warranty: Six Months

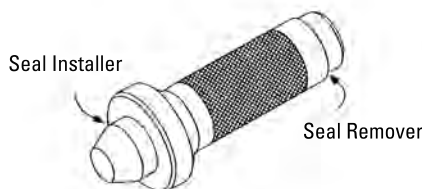

- Used to remove and install ceramic seals on most pumps that use a 5N-6055 Seal Group
- Used with 1U-8306 Socket-Spanner for rebuilding 6I-1898 and 4C-3613 Water Pumps
- One-piece design eliminates need for second tool
- Large end of driver installs seals — greatly reduces chances of damage
- Handle end of driver removes old ceramic seal
- Overall length: 180.0 mm (7.1 in)
- Large diameter: 70.0 mm (2.75 in)

Part Number	Description
9U-6956	Water Pump Seal Installer

## 385-4578 Seal Installer

Model Usage: C32 Marine

Warranty: Six Months



- Used to replace seals on the auxiliary pump
- Prevents seal damage during installation

385-4578 Specifications	
Dimensions	37.0 x 30.1 mm (1.5 x 1.2 in)
Weight	0.05 kg (0.1 lb)

## 221-8647 Seal Installer



- Used to install thermostat seal in housing
- Top portion of installer fits into housing and acts as a guide
- Lower portion slides through guide portion to install seals accurately and efficiently
- Lower portion bolts to handle using a 2D-4534 Bolt (3/8-16)
- Knurled handle makes installer easier to hold

Part Number	Description
221-8647	Seal Installer



## Temporary Strainers

Model: 3400, 3500, 3600 Family Engines

Warranty: Six Months

- Convenient to install in coolant lines on 3600, 3500 and some 3400 Family Engines
- Filter particles larger than 1.58 mm (1/16 in) diameter
- Used during initial startups and after overhauls
- Meant to be removed from cooling system before engine returned to service

Part Number	Description	Material	Perforations	Pipe Size
4C-9045	Temporary Strainer	Stainless Steel	1.58 mm (1/16 in) diameter	101.6 mm (4 in)
4C-9046	Temporary Strainer	Stainless Steel	1.58 mm (1/16 in) diameter	127 mm (5 in)
4C-9047	Temporary Strainer	Stainless Steel	1.58 mm (1/16 in) diameter	152.4 mm (6 in)



## 125-5597 Mounting Bar

Model: 3406E Marine Engine

Warranty: Six Months

- Used to hold heat exchanger plates in alignment during disassembly and assembly
- Makes repair work faster and easier

Part No.	Description	Hex End	Outside Diameter	Threaded End
125-5597	Mounting Bar	19.05 mm (3/4 in)	29.75 mm (1.171 in)	1/2 - 13

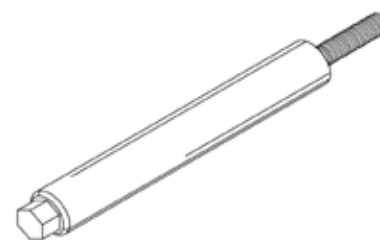

## 237-9608 Mounting Bar

Model: C-18

Warranty: Six Months

Part Number	Description
237-9608	Mounting Bar

- Used to preload aftercooler plates for assembly
- Makes repair work easier and faster
- 2 bars are typically used per aftercooler

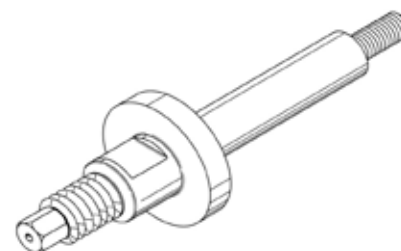

## 334-0114 Mounting Bar

### Essential Tool

Model: C27, C30, C32, and 3412E Marine Engines

Warranty: Six Months

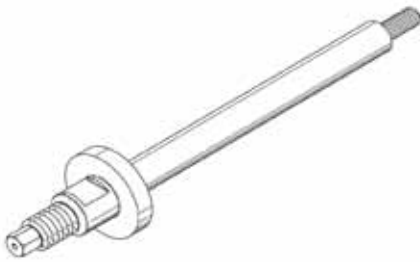

- Used to align and preload aftercooler plates during assembly
- Bars align aftercooler plates and threaded adjuster compresses plates to proper preload
- Makes repair work easier and faster
- Two bars are typically used per aftercooler
- Durable steel construction

#### Reference

SENR5031, Service Manual, 3412E, C30, and C32 Marine Engines, Disassembly and Assembly Manual

Part Number	Description
334-0114	Mounting Bar

## 169-4309 Mounting Bar

Model: 3412 HEUI Marine Engines

Warranty: Six Months



- Used to align heat exchanger plates during disassembly and assembly
- Makes heat exchanger repair work easier and faster
- Two guides are typically used per heat exchanger

#### Reference

SENR5031, Disassembly and Assembly Manual

Hex end	19.05 mm ( 3/4 in)
Outside diameter	29.75 mm (1.171 in)
Threaded end	5/8-11

Part Number	Description
169-4309	Mounting Bar

## FT3045 Angle Bracket

Model: 3516 Generator Set

Warranty: None



- Used to remove and install radiator
- Clamps both segments of radiator core together to make it easier to handle
- Material: SAE 1020M Steel

#### Reference

REN5060, 3500B Engine Disassembly and Assembly Manual

**359-4915 Fan Drive Installer, 359-4916 Fan Drive Installer****Essential Tool**

Model: D6R, D6T Track-Type Tractors, 937D Track-Type Loader

Warranty: Six Months

Item	Part Number	Description
1	359-4915	Fan Drive Installer
2	359-4916	Fan Drive Installer

- Used to install wear sleeves on 336-7696 and 350-5637 Fan Drives
- Provides a way to install wear sleeves without damage to seals or fan drive
- Made from hardened steel and black oxide coated for long service life

**Reference**

REN8175, D6R Series III and D6T Track-Type Tractors, Engine Supplement, Disassembly and Assembly

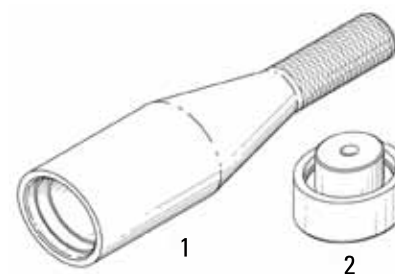
**Assembly Tooling for MESABI Radiator**

Model: 793, 797 Off-Highway Truck

Warranty: Six Months

- Used to assemble MESABI Radiator
- Various tools and lubricating oil provide means to correctly assemble radiator components, including seals
- Special hand tools designed to help prevent damage to the radiator during assembly

**References**

KENR8578, 793F Off-Highway Truck, Engine Supplement, Disassembly and Assembly

KENR8384, 797F Off-Highway Truck, Engine Supplement, Disassembly and Assembly

Part Number	Description
FT3163	As Fixture
FT3164	As Fixture
FT3165	Bracket

Part Number	Description
342-2334	Support Tool
342-2335	Cleaning Brush
342-2346	Lubrication Brush
342-2348	Lubrication Brush
342-2349	Lubricating Oil
4Q-5144	Install Tool
4Q-5222	Breaker Tool

## 373-4792 Turbo Alignment Bracket

Model Usage: CT660 Truck  
Warranty: Manufacturer's

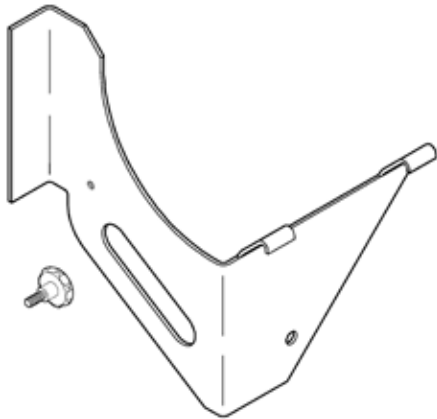

- Required to properly install and align the turbo assembly

Specifications	
Dimensions	355.6 x 279.4 x 304.8 mm (14.0 x 11.0 x 12.0 in)
Weight	2.3 kg (5.0 lb)

Part Number	Description
373-7492	Turbo Alignment Bracket

## 373-4724 Air Compressor Coolant Line Release Tool

Model Usage: CT660 Truck  
Warranty: Manufacturer's

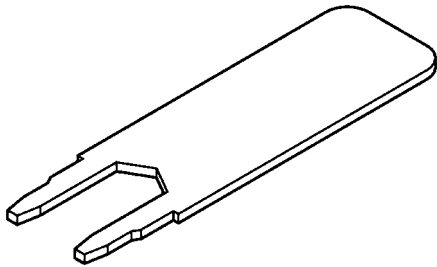

- Used to manually install injector into cylinder head
- Releases the locking mechanism to allow the removal of the coolant line on the air compressor

Specifications	
Dimensions	3 x 1 x 0.25 in
Weight	0.23 kg (0.50 lbs)

Part Number	Description
373-4724	Air Compressor Coolant Line Release Tool

## 373-4793 Charge Air Cooler Test Group

Model Usage: CT660 Truck  
Warranty: Manufacturer's

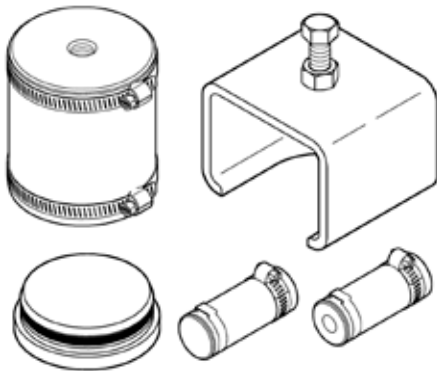

- Used to perform diagnostics on the charge air cooler (intercooler).

Specifications	
Dimensions	177.8 x 134.6 x 134.6 mm (7.0 x 5.3 x 5.3 in)
Weight	2.56 kg (5.65 lb)

Part No.	Description
373-4793	Charge Air Cooler Test Group

**373-4794 Thermostat Housing Extension Tube Seal Installer**

Model Usage: CT660 Truck

Warranty: Manufacturer's

- Used to properly install the extension tube seal into the thermostat housing

Specifications	
Dimensions	137.2 x 177.8 x 134.6 mm (5.4 x 7.0 x 5.3 in)
Weight	0.29 kg (0.65 lb)



Part No.	Description
373-4794	Thermostat Housing Extension Tube Seal Installer

**373-4825 Charge Air Cooler Pipe to High Speed Turbo Extension Tube Seal Installer**

Model Usage: CT660 Truck

Warranty: Manufacturer's

- Used to properly install the extension tube seal into the air charge cooler (inter-cooler) pipe

Specifications	
Dimensions	137.2 x 180.3 x 134.6 mm (5.4 x 7.1 x 5.3 in)
Weight	0.54 kg (1.2 lb)

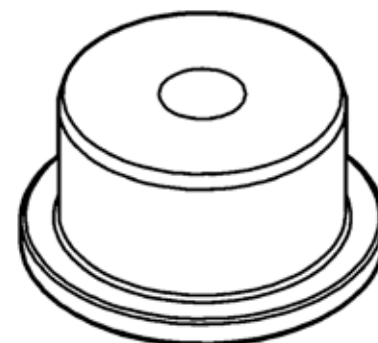

Part Number	Description
373-4825	Charge Air Cooler Pipe to High Speed Turbo Extension Tube Seal Installer

**373-4831 Fan Hub Seal Installer**

Model Usage: CT660 Truck

Warranty: Manufacturer's

- Used to properly install the fan hub housing seal

Specifications	
Dimensions	127.0 x 127.0 x 177.8 mm (5 x 5 x 7 in)
Weight	2.1 kg (4.6 lb)

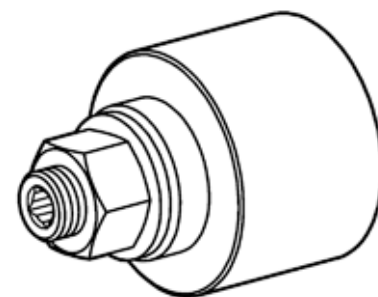

Part Number	Description
373-4831	Fan Hub Seal Installer

## 379-9007 Fan Clutch Wrench

Model Usage: CT660 Truck

Warranty: Manufacturer's

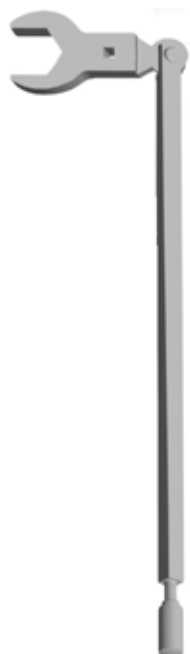

- Used to easily remove fan hub nut on CT660 engines
- Force can be applied using air hammer or by hand using included attachment and standard hammer or mallet
- Fan clutch wrench can be used with 1/2" drive torque wrench to reinstall nut

Specifications	
Dimensions	101.6 x 101.6 x 863.6 mm (4.0 x 4.0 x 34.0 in)
Weight	3.6 kg (7.9 lb)

Part Number	Description
379-9007	379-9007 Fan Clutch Wrench

## 372-5254 Coolant Management Tool

Model Usage: CT660 Truck

Warranty: Manufacturer's



- Equipped with two unique adapters that use standard shop air to create regulated pressure and a powerful vacuum
- Regulated pressure quickly empties entire system
- Single closure valve allows for pressure test
- Vacuum eliminates possibility of air pockets forming in the EGR cooler

Specifications	
Dimensions	439.4 x 528.3 x 1252.2 mm (17.3 x 20.8 x 49.3 in)
Weight	33.1 kg (73 lb)

Part Number	Description
372-5254	Coolant Management Tool

## 385-1861 Coolant Line Plug

Model Usage: All C7 thru C18, Industrial and Captive Engines

Warranty: Manufacturer's

- Used to plug the coolant line to the DEF injector during DPF removal
- Two coolant line plugs are required per engine for this procedure
- Effects all Tier 4 final engines, C7 – C18

Part Number	Description
385-1861	Coolant Line Plug

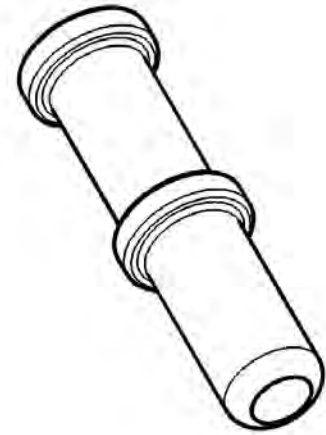

## Crankshaft, Main Bearings and Flywheel

### Crankshaft Gear Installation Tools

Model: Cat® Engines

Warranty: Six Months

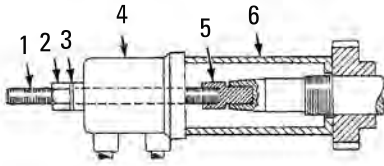

- Used to install crankshaft gears on most engines with tool setup illustrated

Item	Part Number	Description
6	FT1410	Sleeve

Item	Part Number	Description	Thread Size
1	5H-1275	Stud	--
2	1B-4206	Nut	--
3	4D-3704	Washer	--
4	6V-3160	Cylinder Group	--
<b>Thread sizes of adapters (5) are as follows:</b>			
5	5F-7339	Adapter	3/4 in NF - Male x 5/8 in NF - Female
5	5F-7342	Adapter	1 in NF - Male x 5/8 in NF - Female
5	5H-1274	Adapter	1 1/4 in NF - Male x 5/8 in NF - Female
5	5H-1276	Adapter	7/8 in NF - Male x 5/8 in NF - Female

### FT2632 Installer

Model: C10/C12 ADEM3 Engines

Warranty: None

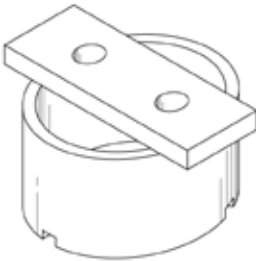

- Used to easily press crankshaft mounted timing ring into position
- Fabricated from 6V-2108 Sleeve Tool by cutting slots into one face
- Bar is used with existing bolts to push sleeve onto crankshaft
- Sleeve material: SAE 1025 tubing
- Bar material: SAE 1018 steel

#### Reference

REN2236, Special Instruction

### 137-7293 Crank Gear Puller

Model: 3116 and 3126 Engines

Warranty: Six Months

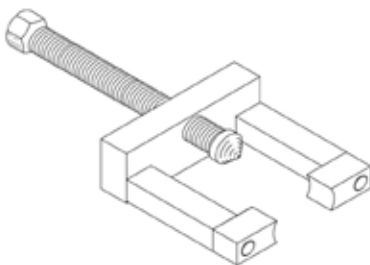

- Used to remove 2W-8147 Gear from crankshaft
- Saves time by allowing crankshaft gear to be removed without removing crankshaft from engine or engine from frame
- Especially useful on 3126 Engines in motor home applications
- Weight: 3 kg (7 lb)
- All items in figure are included

Part Number	Description
137-7293	Crank Gear Puller



## FT1410 Sleeve

Model: Cat® Engines

Warranty: None

- Replacement for 5H-1273 Sleeve
- Material: SAE 1020 steel

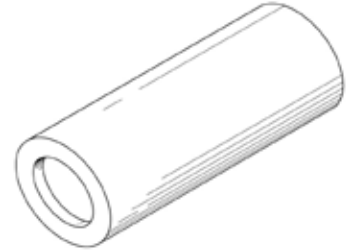

## FT1033 Puller Adapter

Model: D8K

Warranty: None

- Used to facilitate removal of crankshaft pulley and damper on later 13.72 cm (5.4 in) bore, 6-cylinder vehicle engines and D8K Tractor
- Material: SAE 4140 steel

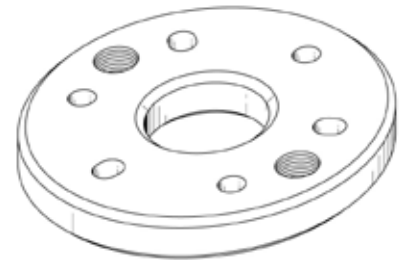

## FT0915 Adapter

Model: 4.75 inch and 5.4 inch Bore Engines

Warranty: None

- Used to facilitate removal of crankshaft pulley and hub on 12.07 cm (4.75 in) and some 13.72 cm (5.4 in) bore engines
- Material: SAE 4140 steel

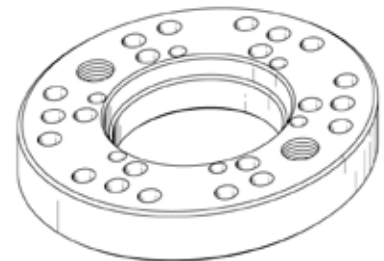

## 5P-3546 Puller Plate

Model: D10, D11N, 245B, 992C

Warranty: Six Months



- Used to remove 9S-3013 Crankshaft Gear on D343 and 1693 Engines
- Used with 6V-3160 Hydraulic Puller, 9M-6592 Guide, three 6F-4991 Bolts, and three 7F-1926 Bolts

Part Number	Description
5P-3546	Puller Plate

## FT1104 Drill Fixture

## FT1120 Chip Deflector

Model: 1674

Warranty: None

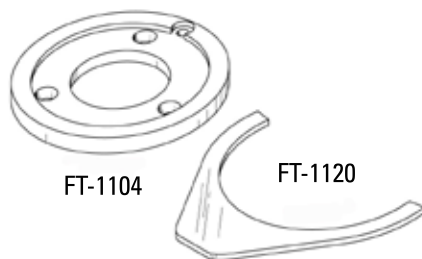

- Used to remove crankshaft gear on 1674 Engine without removing crankshaft from engine
- FT1104 Drill Fixture assembled to crankshaft flange so that drill bushing is aligned with key which positions crankshaft gear; gear removed by drilling partially through gear with solid carbide or carbide-tipped drill; after fixture removed, chisel can be used to break gear from crankshaft
- FT1120 Chip Deflector bent to fit under end of crankshaft before drilling is started

## FT1342 Guide Bolts

Model: 3408, 3408B, 834B, 988B

Warranty: None



- Used to hold crankshaft gear in position when removing and installing flywheel on engines prior to 48W-1713 in 988B Wheel Loaders — if tools are not used, gear can fall off crankshaft and cause damage
- On engines beginning with 48W-1713, fabricated tools not required because cast bosses in flywheel housing prevent gear from falling
- 2 required
- Material: SAE 1020 steel

## FT1576 Puller Plate

Model: D10

Warranty: None

- Used with 9M-6592 Guide and three 1K-9418 Bolts to remove crankshaft gear on D346, D348 and D349 Engines
- Can be fabricated from dimensions given in Detail "A", or by modifying 5P-3546 Puller Plate with dimensions given in Detail "B"

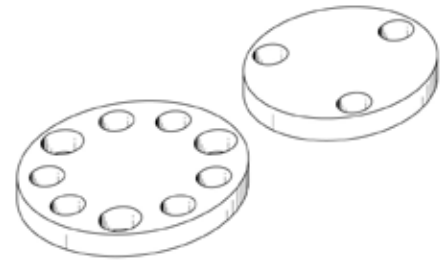

## FT1587 Cold Solvent Tank

Model: Cat® Engines

Warranty: None

- Cold solvent cleaning of crankshafts needed during reconditioning of engines and after crankshafts have been ground
- Sized specifically to clean crankshafts; takes less floor space than commercially available cold solvent tanks that are large enough to clean crankshafts used in most Cat® Engines
- Equipped with pump and filter to remove debris from solvent during use; filter reduces solvent replacement cost; with installation of "tee" fitting at pump outlet, a hose can be added to flush passages in crankshaft
- Pair of 5P-8637 Crankshaft Supports can be used in tank to make it easier to turn crankshaft during cleaning
- Capacity: 400 L (105.6 U.S. gal) when filled with solvent to depth of 254 mm (10 in)

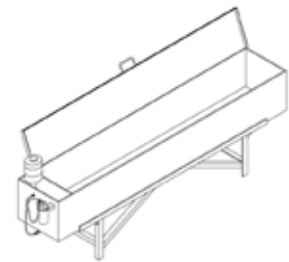

## 5P-8637 Crankshaft Support Group

Model: Cat® Engines

Warranty: Six Months

Part Number	Description	Quantity
5P-8637	Crankshaft Support Group	--
<b>Crankshaft Support Group Consists of:</b>		
0S-0509	Bolt (3/8 - 16)	2
2H-6120	Screw (used with 268-1699)	3
5P-8636	Pad	2
7F-7836	Screw	4

- V-block-type supports used to inspect crankshafts for bend (2 support groups required)
- Replaceable plastic bearing pads will not damage crankshaft

### Reference

SEBF8054, Guideline for Reusable Parts



## 5P-8718 BrakeSaver Rotor Support

Model: 3406, 3406B, 3408, 3408B

Warranty: Six Months



- Used to prevent damage to seals during BrakeSaver removal and installation on 3400 Series Engines
- Attached to engine with four OS-1594 Bolts
- Replaces 9N-0046 design changes

Part Number	Description
5P-8718	BrakeSaver Rotor Support

## FT1895 Plug

### FT1896 Bolt

Model: Cat® Engines with BrakeSavers

Warranty: None



FT1895

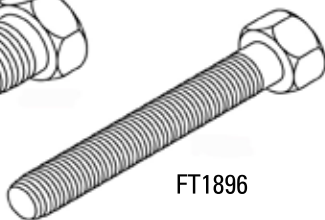

FT1896

- Make replacement of diaphragm in brakesaver control valve easier
- Hold spool valve in place while replacing diaphragm
- Reduce loss of oil

## 8F-4423 Flywheel Lifter

Model: Cat® Engines

Warranty: Six Months



- Used for flywheel removal and installation
- Two lifters can be used for removal and installation of some crankshafts
- Maximum lifting capacity: 454 kg (1000 lb)

Part Number	Description
8F-4423	Lifter - Flywheel

## 393-2572 Flywheel Stopper Plate

Model Usage: C3.8

Warranty: Manufacturer's

- Used to loosen and tighten the flywheel screw

Specifications	
Dimensions	140 x 78.7 mm (5.51 x 3.10 in)
Weight	.662 kg (1.45 lb)

Part Number	Description
393-2572	Flywheel Stopper Plate



## FT1341 Bracket Assembly

Model: 3408, 3408B, 834B, 988B

Warranty: None

- Adaptable to 988B Engine
- Used to prevent crankshaft gear from dropping off crankshaft during removal of flywheel and damaging seals

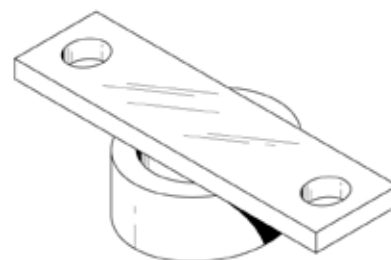

## 364-7209 C4.4 Timing Case Cover Alignment Tool

Model Usage: C4.4

Warranty: Six Months

- Used to correctly align pressed timing case cover for C4.4 engine

Specifications	
Dimensions	Outer Diameter: 79.35 mm (3.12 in)
	Depth: 44.45 mm (1.75 in)
Weight	3.62 kg (8.0 lb)
Material(s)	Steel

Part Number	Description
364-7209	C4.4 Timing Case Cover Alignment Tool

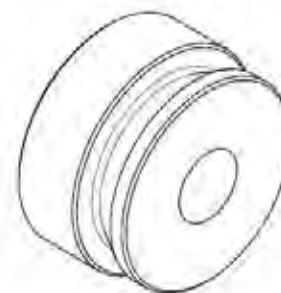

## 364-7210 Timing Case Cover Alignment Tool

Model Usage: C7.1, C6.6

Warranty: Six Months

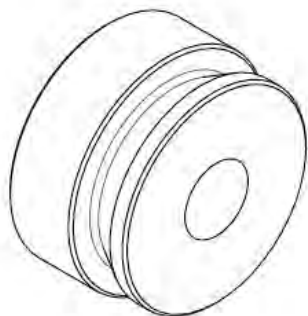

- Used to correctly align pressed timing case cover

Specifications	
Dimensions	Outer Diameter: 79.35 mm (3.12 in)
	Depth: 44.45 mm (1.75 in)
Weight	1.12 kg (2.49 lb)
Material(s)	Steel

Part Number	Description
364-7210	Timing Case Cover Alignment Tool

## 9U-7994 Flywheel Guide Pin

Model: 3046 Diesel Engine

Warranty: Six Months



- Used to remove and install flywheel (2 required)
- Supports weight and aligns flywheel during engine assembly
- Simple to use (threaded guide pin has screwdriver slot for easy installation)
- Thread: M12 x 1.25
- Overall length: 190 mm (7.5 in)

Part Number	Description
9U-7994	Flywheel Guide Pin

### Reference

SEN6458, Special Instruction, Disassembly and Assembly of 3046 Engines

## 5P-3022 Wear Sleeve and Seal Installer

Model: Cat® Engines

Warranty: Six Months



- Used to install both front and rear seals and wear sleeves on 15.88 cm (6.25 in) bore V-engines
- Also included with 3N-8008 Crankshaft Seal Conversion Group, Front, and 3N-8000 Crankshaft Seal Conversion Group, Rear, for replacing former piston ring-type seal, thrower, and baffle

Part Number	Description
5P-3022	Wear Sleeve and Seal Installer

## FT2711 Special Bolt

## FT2712 Guide Stud

Model: 3196 Rear Power Take-Off Engines and 365B Hydraulic Excavator

Warranty: None

- Used to align and support rear crankshaft gear while oil seal is being installed
- Eliminates oil seal damage during installation
- Guide studs align crankshaft gear (3 required)
- Special bolts lock crankshaft gear into position (2 required)
- Special bolt made from: 095-0705 Socket Head Hex Bolt
- Material for FT2712: SAE 4140 steel

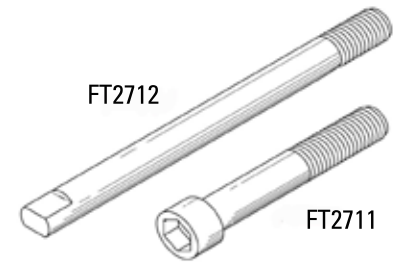

## Crankshaft Seal and Wear Sleeve Installation Tools (Silicone and Hydrodynamic)

Model: 1100, 3100, 3200, 3300, 3400

Warranty: Six Months

- Typical tools for installing silicone and hydrodynamic-type oil seals and wear sleeves

### Reference

SMHS7100-02, Special Instruction

SMHS8508, Special Instruction

SMHS8301, Special Instruction

SMHS6959-01, Special Instruction

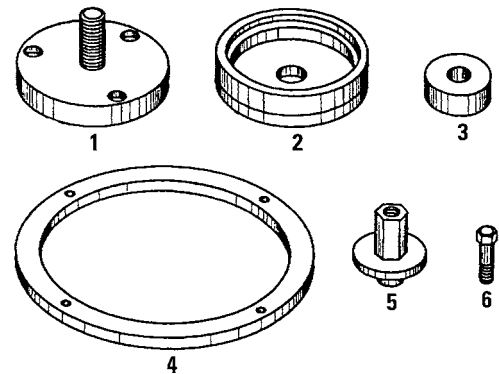

CURRENT ENGINES				
Item	Location	Part Number	Description	Qty.
<b>1100 and 3100 Engines - Silicon Seals - SMHS7100</b>				
1	Rear	5P-0290	Locator	--
2	Front	9S-6030	Installer	--
2	Rear	5P-7293	Installer	--
3, 4	Front	6V-7777	Other Part	--
5	Front and Rear	9S-8858	Nut Assembly	--
6	Rear	1P-5515	Bolt	2
--	Front and Rear	5P-7312	Distorter	--
--	Rear	5P-7338	Distorter Ring / Adapter	--
<b>3034</b>				
2	Front	159-9074	Front Seal Installer	--
2	Rear	159-9071	Rear Seal Installer	--
3, 4	Front and Rear	159-9076	Rear Drive Handle	--

CURRENT ENGINES				
Item	Location	Part Number	Description	Qty.
<b>3054 and 3056</b>				
1	Front	9U-6208	Locator <sup>1</sup>	--
2	Front	9U-6207	Plate	--
2	Front	9U-6211	Installer	--
2	Rear	9U-6203	Installer	--
3, 4	Front	9U-6209	Sleeve	--
3, 4	Front	9U-6206	Stud	--
3, 4	Rear	9U-6204	Seal Guide	--
3, 4	Rear	9U-6202	Plate	--
6	Front	089-7989	Bolt	3
--	Front Group	9U-6210	Installer Group	--
<b>3064 and 3066</b>				
1	Rear	9U-6171	Locator	--
2	Front	9U-6179	Washer	--
2	Rear	9U-6169	Installer	--
2	Rear	6V-3303	Bolt	--
3, 4	Front	9U-6178	Installer Stud	--

(Continued)

# Crankshaft, Main Bearings and Flywheel

## Crankshaft Seal and Wear Sleeve Installation Tools (Silicone and Hydrodynamic) (Continued)

Model: 1100, 3100, 3200, 3300, 3400

Warranty: Six Months

Engine Tools

CURRENT ENGINES				
Item	Location	Part Number	Description	Qty.
<b>3064 and 3066 (Continued)</b>				
3, 4	Rear	5P-8247	Hard Washer	--
6	Rear	9U-6172	Bolt	2
--	Front Group	9U-6180	Front Seal Installer Group	--
--	Rear Group	9U-6170	Rear Seal Installer Group	--
<b>3046</b>				
1	Rear	4C-6375	Locator	--
2	Front	4C-6378	Seal Installer Sleeve	--
2	Rear	6V-3303	Bolt	--
2	Rear	127-1591	Rear Oil Seal Installer	--
3, 4	Front	4C-6376	Installer Stud	--
3, 4	Front	4C-6377	Installer Washer	--
3, 4	Rear	5P-8247	Hard Washer	--
6	Rear	9U-6172	Bolt	2
<b>3200 and 3204 Engines - Silcon Seals - SMHS7100</b>				
1	Rear	5P-0290	Locator	--
2	Front	9S-6030	Installer	--
2	Rear	8T-3098	Installer	--
2	Rear	5P-7293	Installer	--
3, 4	Front	6V-7777	Other Part	--
5	Front and Rear	9S-8858	Nut Assembly	--
6	Rear	1P-5515	Bolt	2
--	Front and Rear	5P-7312	Distorter	--
--	Rear	5P-7338	Distorter Ring / Adapter	--
<b>3208 Engines - Silcon Seals - SMHS7100</b>				
1	Rear	5P-0290	Locator	--
2	Front	5P-4194	Installer	--
2	Rear	5P-7293	Installer	--
3, 4	Front	5P-4230	Other Part	--
5	Front and Rear	9S-8858	Nut Assembly	--
6	Rear	1P-5515	Bolt	2
--	Front and Rear	5P-7312	Distorter	--
--	Rear	5P-7338	Distorter Ring / Adapter	--

CURRENT ENGINES				
Item	Location	Part Number	Description	Qty.
<b>3208 Engines - Hydrodynamic Seals - SMHS8508</b>				
1	Rear	5P-0290	Locator	--
2	Front	4C-4234	Installer <sup>2</sup>	--
2	Rear	5P-7293	Installer	--
5	Front and Rear	9S-8858	Nut Assembly	--
6	Rear	1P-5515	Bolt	2
--	Front and Rear	5P-7312	Distorter	--
--	Rear	5P-7338	Distorter Ring / Adapter	--
<b>3300 Engines - Silcon Seals - SMHS7100</b>				
1	Rear	9S-8871	Locator	3
2	Front	4C-8982	Installer	--
2	Rear	5P-7298	Installer	--
5	Front and Rear	9S-8858	Nut Assembly	--
6	Rear	9S-8890	Bolts	3
6	Rear	7F-8022	Bolt	1
--	Front	5P-7315	Distorter Ring	--
--	Front and Rear	5P-7312	Distorter	--
--	Rear	5P-7313	Distorter Ring	--
<b>3300 Engines - Hydrodynamic Seals - SMHS8508</b>				
1	Rear	9S-8871	Locator	3
2	Front	4C-8982	Installer	--
2	Rear	6V-7876	Installer	--
2	Rear	1U-8585	Installer	--
2	Rear	6V-7877	Installer	--
5	Front and Rear	9S-8858	Nut Assembly	--
6	Rear	2P-1956	Bolt	--
6	Rear	7F-8022	Bolt	1
--	Front	5P-7315	Distorter Ring	--
--	Front	9Y-9895	Seal Group	1
--	Front and Rear	5P-7312	Distorter	--
--	Rear	5P-7313	Distorter Ring	--
<b>3114 and 3116 Engines - Hydrodynamic Seals - SMHS8508, SEHS8868</b>				
2	Front	1U-7430	Front Crank Seal Installer	--
2	Rear	1U-7594	Rear Installer	--
3, 4	Rear	1U-7597	Sleeve Ring	--

(Continued)



## Crankshaft Seal and Wear Sleeve Installation Tools (Silicone and Hydrodynamic) (Continued)

Model: 1100, 3100, 3200, 3300, 3400

Warranty: Six Months

CURRENT ENGINES				
Item	Location	Part Number	Description	Qty.
<b>3114 and 3116 Engines - Hydrodynamic Seals - SMHS8508, SEHS8868 (Continued)</b>				
5	Front and Rear	9S-8858	Nut Assembly	--
6	Rear	1U-7596	Modified by Cat® Bolt	--
--	--	171-7212	Wear Sleeve	--
--	Front and Rear	5P-7312	Distorter	--
--	Rear	4C-4869	Distorter Ring	--
--	--	5P-6208	Wear Sleeve Installer	--
<b>3114, 3116 and 3126 HEUI Engines - Hydrodynamic Seals - SMHS8508</b>				
1	Rear	132-8772	Locator	2
2	Front	1U-7430	Front Crank Seal Installer	--
2	Rear	1U-7594	Rear Installer	--
3, 4	Rear	1U-7597	Sleeve Ring	--
5	Front and Rear	9S-8858	Nut Assembly	--
6	Rear	1U-7596	Modified by Cat® Bolt	--
--	--	171-7212	Wear Sleeve	--
--	Front and Rear	5P-7312	Distorter	--
--	Rear	4C-4869	Distorter Ring	--
--	--	5P-6208	Wear Sleeve Installer	--
<b>3176, 3196, C-10 and C-12<sup>3</sup></b>				
--	Front	145-5247	Wear Sleeve Installer	--
--	Front	9Y-0821	Wear Sleeve	--
--	Rear	9Y-0810	Wear Sleeve	--
--	Rear	147-2675	Wear Sleeve Installer	--
<b>3400 Engines - Silcon Seals - SMHS7100</b>				
1	Front and Rear	5P-1733	Locator	--
1	Rear	5P-7301	Locator	--
2	Front	6V-2086	Installer	--
2	Rear	6V-2087	Installer	--
5	Front and Rear	9S-8858	Nut Assembly	--
6	Front and Rear	5P-1737	Bolt	3

CURRENT ENGINES				
Item	Location	Part Number	Description	Qty.
<b>3400 Engines - Silcon Seals - SMHS7100 (Continued)</b>				
6	Rear	5P-7310	Bolt	2
6	Rear	5P-7309	Bolt	2
--	Front and Rear	5P-7314	Distorter Ring	--
--	Front and Rear	5P-7312	Distorter	--
<b>3400 Engines - Hydrodynamic Seals - SMHS8508</b>				
1	Front and Rear	5P-1733	Locator	--
1	Rear	5P-3594	Locator	--
1	Rear	5P-7301	Locator	--
2	Front	6V-6142	Installer	--
2	Rear	8T-2855	Installer	--
2	Rear	8T-2683	Installer	--
2	Rear	6V-6143	Installer	--
3, 4	Rear	8T-2856	Other Part	--
5	Front and Rear	9S-8858	Nut Assembly	--
6	Front and Rear	5P-1737	Bolt	3
6	Rear	5P-7309	Bolt	2
6	Rear	1T-0720	Bolt	2
6	Rear	5P-7310	Bolt	2
--	Front and Rear	5P-7314	Distorter Ring	--
--	Front and Rear	5P-7312	Distorter	--
--	Rear	5P-7409	Sleeve Distorter	--
<b>3500 Engines - Hydrodynamic Seals - SMHS8508</b>				
1	Front and Rear	6V-4003	Locator	--
1	Rear	192-6339	Crankshaft Seal Locator Assembly	--
2	Front and Rear	8T-3099	Installer	--
2	Front and Rear	6V-4977	Installer	--
2	Rear	187-1841	Seal And Wear Sleeve Installer	--
3, 4	Front and Rear	6V-4001	Other Part	--
3, 4	Front and Rear	6V-4002	Other Part	--
5	Front and Rear	9S-8858	Nut Assembly	--

(Continued)

# Crankshaft, Main Bearings and Flywheel

## Crankshaft Seal and Wear Sleeve Installation Tools (Silicone and Hydrodynamic) (Continued)

Model: 1100, 3100, 3200, 3300, 3400

Warranty: Six Months

Engine Tools

CURRENT ENGINES				
Item	Location	Part Number	Description	Qty.
<b>3500 Engines - Hydrodynamic Seals - SMHS8508 (Continued)</b>				
5	Rear	2J-3505	Full Nut	4
6	Front and Rear	2N-5006	Bolt	2
--	Front and Rear	1U-7325	Distorter Adapter	--
--	Front and Rear	6V-3143	Distorter Adapter	--
--	Rear	5P-7409	Sleeve Distorter	--
<b>C27/C32 Engines - Hydrodynamic Seals - SMHS8508</b>				
1	Front and Rear	5P-1733	Locator	--
1	Rear	249-2937	Locator	--
2	Front	6V-6142	Installer	--
2	Rear	6V-6143	Installer	--
5	Front and Rear	9S-8858	Nut Assembly	--
--	Front and Rear	5P-7312	Distorter	--
--	Front and Rear	5P-7314	Distorter Ring	--
<b>C175 Engines - Hydrodynamic Seals - SMHS8508</b>				
1	Front and Rear	250-4586	Locator	--
2	Front and Rear	250-4587	Installer	--
3, 4	Front and Rear	323-4712	Other Part	--
5	Front and Rear	9S-8858	Nut Assembly	--
6	Front and Rear	322-2078	Bolt	--
--	Front and Rear	1U-7325	Distorter Adapter	--
--	Rear	5P-7409	Sleeve Distorter	--
<b>D343 (5.4 in) 6 Cylinder Engines - Silicon Seals - SMHS7100</b>				
1	Front	9S-8876	Locator	--
1	Rear	9S-8870	Locator	--
2	Front	5P-7295	Installer	--
2	Rear	5P-7294	Installer	--
5	Front and Rear	9S-8858	Nut Assembly	--
6	Front	9S-8889	Bolt	2
6	Rear	2P-2346	Bolt	3
--	Front	5P-7316	Distorter Ring	--

CURRENT ENGINES				
Item	Location	Part Number	Description	Qty.
<b>D343 (5.4 in) 6 Cylinder Engines - Silicon Seals - SMHS7100 (Continued)</b>				
--	Front and Rear	5P-7312	Distorter	--
<b>D348 (5.4 in) 60 degree Vee Engines - Silicon Seals - SMHS7100</b>				
1	Front	5P-7302	Locator	--
1	Rear	9S-8874	Locator	--
2	Front	5P-7297	Installer <sup>4</sup>	--
5	Front and Rear	9S-8858	Nut Assembly	--
6	Front	9S-8889	Bolt	2
6	Front and Rear	9S-8893	Bolt	3
--	Front	5P-7316	Distorter Ring	--
--	Front and Rear	5P-7312	Distorter	--
<b>(5.4 in) 60 degree Vee Engines - Hydrodynamic Seals - SMHS8508</b>				
1	Front	5P-7302	Locator	--
1	Rear	9S-8874	Locator	--
2	Front	4C-5822	Installer	--
2	Rear	9U-5114	Seal and Wear Sleeve Installer	--
5	Front and Rear	9S-8858	Nut Assembly	--
6	Front	9S-8889	Bolt	2
6	Front and Rear	9S-8893	Bolt	3
--	Front	5P-7316	Distorter Ring	--
--	Front	7C-7473	Seal	--
--	Front and Rear	5P-7312	Distorter	--
--	Rear	7C-7474	Seal	--
<b>D379, D398, D399, G379, G398 and G399 Engines - Hydrodynamic Seals - SMHS8301</b>				
1	--	6V-7829	Locator	--
2	--	6V-7831	Installer	--
3, 4	--	6V-7833	Other Part	--
3, 4	--	6V-7799	Other Part	--
5	Front and Rear	9S-8858	Nut Assembly	--
6	--	4B-5271	Bolt	6
6	--	3B-1915	Bolt	6
6	--	6V-9442	Bolt	2

(Continued)

## Crankshaft Seal and Wear Sleeve Installation Tools (Silicone and Hydrodynamic) (Continued)

Model: 1100, 3100, 3200, 3300, 3400

Warranty: Six Months

CURRENT ENGINES				
Item	Location	Part Number	Description	Qty.
<b>D379, D398, D399, G379, G398 and G399 Engines - Hydrodynamic Seals - SMHS8301 (Continued)</b>				
6	--	6V-7834	Bolt	2

<sup>1</sup> Includes 089-7989 Bolt

<sup>2</sup> Use stud instead of damper bolt

<sup>3</sup> 3196 Rear Gear Train Parts: FT2712 (Qty 3) and FT2711 Bolts (Qty 2)

<sup>4</sup> FT2323, made from 5P-7297

## Crankshaft Seal and Wear Sleeve Installation Tools (Silicone and Hydrodynamic): Non-Current Engines

NON-CURRENT ENGINES				
Item	Location	Part Number	Description	Qty.
<b>D342 and 5.75 in Bore Engines - Silicon Seals - SMHS6959-01</b>				
2	Front	5P-6543	Installer	--
4	Front	5P-3036	Ring	--
4	Front	5P-6545	Ring	--
6	Front	5S-8096	Bolt	--
--	Front	5P-3037	Plate	--
<b>D334, 1674 and 4.75 in Bore Engines - Silicon Seals - SMHS6959-01<sup>1</sup></b>				
1	Front	9S-8876	Locator	--
4	Front	9S-8537	Ring <sup>2</sup>	--
4	Front	9S-8545	Ring <sup>3</sup>	--
5	Front and Rear	9S-8858	Nut Assembly	--
6	Front	9S-8889	Bolt	2

NON-CURRENT ENGINES				
Item	Location	Part Number	Description	Qty.
<b>D334, 1674 and 4.75 in Bore Engines - Silicon Seals - SMHS6959-01<sup>4</sup></b>				
5	Front and Rear	9S-8858	Nut Assembly	--
--	Rear	9S-8864	Plate	--
6	Rear	8S-4950	Cap ( 9/16 in - 18 thd)	2
<b>D336, 1676 and 4.5 in Bore Engines - Silicon Seals - SMHS6959-01</b>				
1	Front	9S-8876	Locator	--
5	Front and Rear	9S-8858	Nut Assembly	--
6	Rear	9S-8892	Bolt	--
6	Front	9S-8889	Bolt	2
--	Rear	9S-8864	Plate	--

<sup>1</sup> 1674 Bore Engine: 92B322-Up, 93B292-Up, 94B675-Up or prior engines reworked with discontinued 9S-0124 or 1N-5466 Crankshaft Assemblies

<sup>2</sup> Not used on D334 Marine Engines

<sup>3</sup> Not used on D334 Industrial or 1674 Engines

<sup>4</sup> 1674 Bore Engine: 92B1-92B331, 93B1-93B291, 94B1-94B674 with discontinued 4S-5349 and discontinued 7L-5188 Crankshaft Assemblies

## 193-0233 PTO Oil Seal Installer

Model: 3408 and 3412 Engines

Warranty: Six Months

- Tool must be used to install the 160-8181 PTO Shaft Seal (Seal is included in the 178-2973 Seal Kit)
- Used with nut and washer of PTO yoke to push seal into position
- Decreases installation time (uses positive stop to accurately set depth of seal)
- Made from hardened steel for added durability

Part Number	Description
193-0233	PTO Oil Seal Installer



# Crankshaft, Main Bearings and Flywheel

## 422-7508 PTO Seal Installer Tool Assembly

Model Usage: 3500 Machine Engines

Warranty: Six Months



- Used to quickly and easily install rear PTO oil seal
- Necessary to correctly install seal without damage
- Decreases installation time
- Made from steel with black oxide coating

Specifications		
Part Number	Dimensions	Weight
422-7508	152.5 x 101.6 mm (6.0 x 4.0 in)	4.25 kg (9.37 lb)

## FT3142 Seal Installer

Model: 793D and 797B Off-Highway Trucks

Warranty: None



- Used to install 119-6354 PTO Shaft Seal, which is part of 119-6355 Seal Kit
- Used with nut and washer of PTO yoke to push seal into position
- Necessary to correctly install seal without damage
- Decreases installation time (uses positive stop to accurately set depth of seal)
- Made from high-density plastic (ATSM D4000)

### References

REN9717, 3500B High Displacement Engines for Caterpillar Built Machines

SEN91126, 3500B Engines for Caterpillar Built Machines

KEN8117, 3512C Engines for Caterpillar Built Machines

SEN91486, 3512B and 3516B Engine Supplement for 784C, 785C and 785C HAA Off-Highway Truck/Tractors

## Wear Sleeve Installers

Model: 3176, 3176B, C-10, and C-12 Engines

Warranty: Six Months

- Used to quickly and easily install crankshaft wear sleeves

Part Number	Description	Use
145-5247	Wear Sleeve Installer	Front Crankshaft Sleeves
147-2675	Wear Sleeve Installer	Rear Sleeves

## 393-2571 Crankshaft Sleeve Installation Tool

Model Usage: C3.8

Warranty: Manufacturer's



- Used to easily install rear crank seal and wear sleeve

Specifications	
Dimensions	130 x 115.1 mm (5.12 x 4.53 in)
Weight	2.02 kg (4.45 lbs)

Part Number	Description
393-2571	Crankshaft Sleeve Installation Tool

## 9U-6170 Installer Group

Model: 3064 and 3066 Engines

Warranty: Six Months

- Used to install rear seal and wear sleeve onto crankshaft (assures seal lip will bear uniformly around the crankshaft)
- Prevents seal damage during installation — longer seal life
- Group includes all items in figure

### Reference

SENR5553, Service Manual



Item	Part Number	Description	Size
1	9U-6169	Installer	--
2	9U-6171	Locator	--
3	9U-6172	Bolt	M12 x 1.25 x 20 mm long
4	5P-8247	Hard Washer	15.875 mm (0.625 in)
5	6V-3303	Bolt	M16 x 2 x 60 mm long
--	9U-6170	Rear Seal Installer Group	--

## 5P-7318 Wear Sleeve Distorter Group

Model: D10, D9N, D8K, 631E, 637E

Warranty: Six Months

- Used to remove all 1.58 mm (0.062 in) thick crankshaft front and rear wear sleeves
- Prevents damage to crankshaft
- Removal in-chassis takes just a few minutes
- Group includes all items in figure



Item	Part Number	Description	Size	Where Used
--	5P-7318	Wear Sleeve Distorter Group	--	--
1	5P-7312	Distorter	--	--
<b>Distorter Rings</b>				
--	5P-7313	Distorter Ring	--	3300 Series, Rear
--	5P-7314	Distorter Ring	--	3400 Series, Front and Rear
--	5P-7315	Distorter Ring	--	3300 Series, Front
--	5P-7316	Distorter Ring	14.61 cm (5.75 in)	D-Series Engines
--	5P-7317	Distorter Ring	13.72 cm (5.4 in)	D-Series Engines
--	5P-7338	Distorter Ring / Adapter	--	1100, 3100, 3200 Series, Rear

## 4C-4869 Distorter Ring

Model: 3114, 3116, 910E

Warranty: Six Months

- Used with 5P-7312 Distorter to remove rear crankshaft wear sleeve from 1.1 liter engine
- Wear sleeve removal can be difficult without use of distorter and distorter ring to expand sleeve away from crankshaft; after wear sleeve is expanded on journal, it can easily be removed without damaging sealing surfaces

Part Number	Description
4C-4869	Distorter Ring

## 155-8795 Crankshaft Distortion Gauge

Model: All Engines, 3500 and Up

Warranty: Six Months

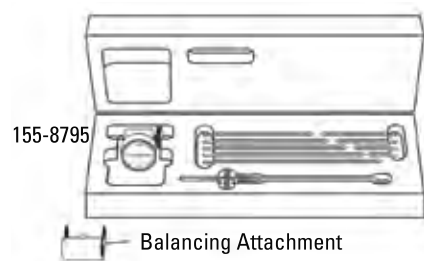

- Used to check crankshaft bearing alignment or shaft deflection without engine disassembly
- Also used as a strain gauge on frame of running engine
- Will stay in any position for hands free operation
- Comes with ten rods (varying sizes)
- Sharp rod points hold gauge on surfaces with an angle up to 45 degrees
- Balancing attachment maintains face of indicator in any desired position
- Attractive protective case
- Group includes all items in figure

Dial indicator graduations	0.02 mm
Dial reading	0-50-0
Range per revolution	1 mm (0.03 in)
Travel length	4.0 mm (0.16 in)
Range	61 - 458 mm (2.4 - 18 in)
Balancing attachment quantity	2

Part Number	Description
155-8795	Crankshaft Distortion Gauge

## 5P-7409 Distorter

Model: Cat® Engines

Warranty: Six Months



- Used to remove 1.58 mm (0.062 in) thick crankshaft wear sleeves on engines equipped with BrakeSavers
- Appropriate distorter ring must be selected from 5P-7318 Distorter Group

Part Number	Description
5P-7409	Sleeve Distorter

## 1U-8585 Installer

Model: 3300 Family Engines

Warranty: Six Months

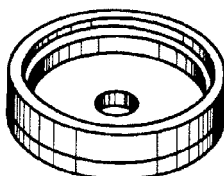

- Required to install new double lip 7C-4297 Seal Group in rear of block for crankshaft

Part Number	Description
1U-8585	Installer

## 1U-7325 Distorter Adapter

Model: 3508, 3512, 3516, 789, 793, 994

Warranty: Six Months

- Used with 5P-7409 Distorter to remove front and rear crankshaft wear sleeves from 3500 Series Engines with 1W-6974 Seal Group and 1W-6977 Seal Group
- Positions 5P-7409 Distorter properly against flywheel and timing gear housing for wear sleeve removal, a difficult task without the use of a distorter and adapter to expand sleeve away from crankshaft; once expanded on journal, wear sleeve can be easily removed

Part Number	Description
1U-7325	Distorter Adapter

## 6V-3143 Distorter Adapter

Model: 3500 Engines

Warranty: Six Months

Part Number	Description
6V-3143	Distorter Adapter

- Used with 5P-7409 Wear Sleeve Distorter to remove crankshaft wear sleeves



## FT0125 Pilot

Model: D311H, D320, D330, D333, G333 and 1673 Engines

Warranty: None

- Used with FT0126 Sleeve to install crankshaft oil seal
- Material: SAE 4140 steel

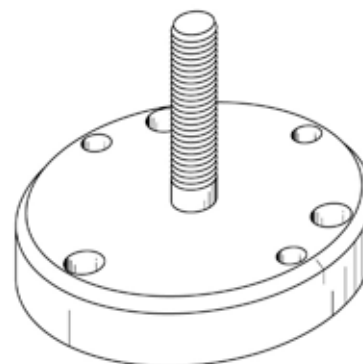

## FT2794 Crankshaft Seal Installer

Model: 3508 Engines in D10R Track-Type Tractors

Warranty: None



- Used to install front crankshaft seal
- Used with two 3E-3883 Eyebolts
- Allows in-chassis installation
- Greatly reduces labor time

### Reference

Service Manual, D10R Disassembly and Assembly

## FT0126 Sleeve

Model: Cat® Engines

Warranty: None



- Used with FT0125 Pilot for oil seal installation

## 4C-5501 Alignment Tool

Model: 416, 426, 428, 3054

Warranty: Six Months



- Used when installing front cover on 3054 engine in 416 Backhoe Loader
- Fits around crankshaft into seal recess in cover and centers cover and seal on crankshaft
- Helps prevent seal damage during cover installation and ensures seal lip will bear uniformly around crankshaft to provide long seal life

Part Number	Description
4C-5501	Alignment Tool



## 9U-6200 Alignment Group

Model: 3056 Engines  
Warranty: Six Months

Part Number	Description
9U-6201	Alignment Group

- Used to install front cover (correctly aligns it for easier installation)
- Designed to fit around crankshaft and into seal recess — centers cover on crankshaft
- Prevents seal damage during installation and helps assure uniform contact of seal lip — two advantages that extend seal life



**Reference**  
SEN5555, Service Manual

## FT2806 Seal Installer Ring

Model: 3054, 3056 Engines  
Warranty: None

- Used to install rear crankshaft oil seal
- Material: SAE1018 steel

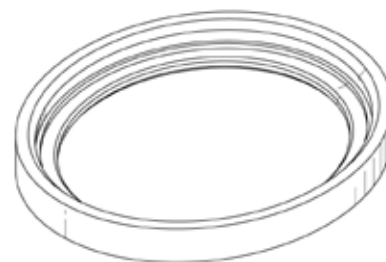

## 9U-5114 Seal and Wear Sleeve Installer

Model: D346, D348, D349  
Warranty: Six Months

- Required to locate 7C-7474 Seal and Wear Sleeve, Rear, on D346, D348 and D349 Engines, 5.4 bore, 60° Vee

Part Number	Description
9U-5114	Seal and Wear Sleeve Installer

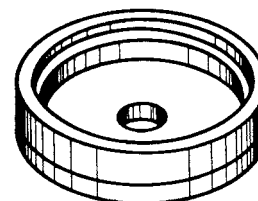

## Crankshaft Oil Seal Installers

### Essential Tool

Model: 3034 Engines  
Warranty: Six Months

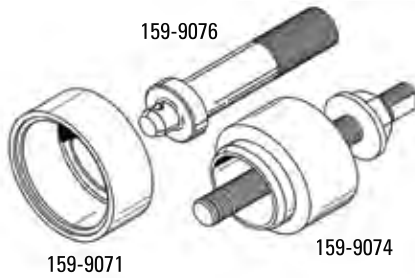

- Used to install front and rear crankshaft oil seals
- 159-9074 for front and 159-9071 for rear crank seal
- 159-9076 Handle used with 159-9071

Part Number	Description
159-9074	Front Seal Installer
159-9071	Rear Seal Installer
159-9076	Rear Drive Handle

#### Reference

SENR5013, Engine Disassembly and Assembly Module

## 393-2570 Gear Case Oil Seal Installation Tool

Model Usage: C3.8  
Warranty: Manufacturer's



- Used to easily install gear case oil seal

Specifications	
Dimensions	86.4 x 148.8 mm (3.40 x 5.86 in)
Weight	1.06 kg (2.33 lbs)

Part Number	Description
393-2570	Gear Case Oil Seal Installation Tool

## 1U-7430 Front Seal Installer

## 1U-7598 Rear Seal Installer Group

Model: 3114, 3116  
Warranty: Six Months



- Required for disassembly, assembly and adjusting of 1.1 liter engine, fuel system, and governor
- 1U-7430 Front Seal Installer used to install crankshaft front seal
- 1U-7598 Rear Seal Installer Group used to install crankshaft rear seal and its mating wear sleeve

#### References

SENR3582, Specification Module  
SENR3583, System Operation Testing and Adjusting  
SENR3611, Disassembly and Assembly Manual  
SEHS8868, Special Instruction, operation

Part Number	Description
1U-7430	Front Crank Seal Installer
1U-7598	Rear Seal Installer Group
<b>Group Consists of:</b>	
1U-7594	Rear Installer
1U-7596	Modified by Cat® Bolt
1U-7597	Sleeve Ring
9S-8858	Nut Assembly

## 9U-6180 Front Seal Installer Group

Model: 3064 and 3066 Engines  
Warranty: Six Months

Item	Part No.	Description
--	9U-6180	Front Seal Installer Group
<b>Group Consists of:</b>		
1	9U-6179	Washer
2	9U-6178	Installer Stud
3	9U-6181	Sleeve

- Used to install crankshaft front seal without removing front cover
- Makes installation easier and prevents damage to seals
- Assures uniform contact around crankshaft (ultimately provides longer seal life)

**Reference**  
SENR5553, Service Manual, 3066 Diesel Engines



## 9U-6210 Installer Group

Model: 3054 and 3056 Engines  
Warranty: Six Months

- Used to install crankshaft front oil seal to proper depth of 9.3 mm (0.37 in)
- Prevents seal damage

**Reference**  
SENR5547, Service Manual, Service Module in SENR5555

Item	Part Number	Description	Quantity
--	9U-6210	Installer Group	--
<b>Group Consists of:</b>			
1	9U-6206	Stud	--
2	9U-6207	Plate	--
3	9U-6208	Locator <sup>1</sup>	--
4	9U-6209	Sleeve	--
5	9U-6211	Installer	--
6	089-7989	Bolt	3

<sup>1</sup> Includes 089-7989 Bolt

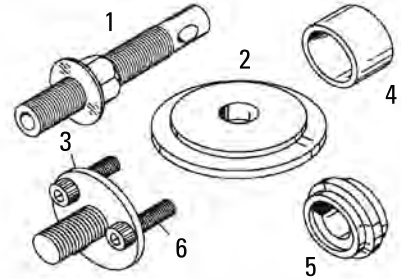

## 9U-6205 Rear Seal Installer Group

Model: 3054 and 3056 Engines  
Warranty: Six Months

Item	Part No.	Description
--	9U-6205	Rear Seal Installer Group
<b>Group Consists of:</b>		
1	9U-6202	Plate
2	9U-6203	Installer
3	9U-6204	Seal Guide

- Used to install rear seal onto crankshafts (assures seal lip will conform uniformly around crankshaft)
- Prevents seal damage during installation — longer seal life

**Reference**  
SENR5555, Service Manual



## Cat® C6.6 Engine / Perkins Vista D Engine Tools

### Essential Tool

Model: C6.6 Engines

Warranty: None

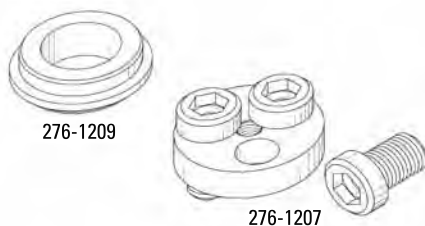

Part Number	Description	Use
276-1207	Front Crankshaft Locator	Install front shaft seal in engine
276-1209	Installer	Install front shaft seal in engine

## 383-1654 Main Bearing Installation Tool

Model Usage: Cat® 3054, C4.4, C6.6

Warranty: Six Months



- Used to install main bearings during rework process

Specifications	
Dimensions	104.3 x 44.7 x 12.0 mm (4.11 x 1.76 x .47 in)
Weight	.01 kg (.02 lb)
Material	Plastic

Part Number	Description
383-1654	Main Bearing Installation Tool

## 278-2636 Seal Removal Tool

### Essential Tool

Model: C6.6 Engines

Warranty: Six Months

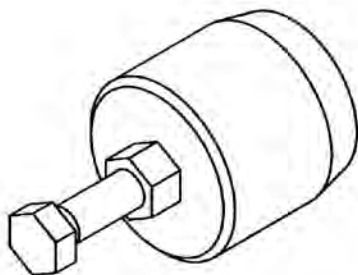

- Used to remove front main oil seal
- Used with 1U-7600 Puller Group

Part Number	Description
278-2636	Seal Removal Tool

## 4C-6375 Locator

### 127-1591 Rear Oil Seal Installer

Model: 3046 Diesel Engine

Warranty: Six Months

#### 4C-6375

- Used to install crankshaft rear seal (assures seal lip will bear uniformly around crankshaft)
- Prevents seal damage during installation

#### 127-1591

- Reversible
- Used to install 103-2835 Rear Crankshaft Oil Seal Assembly and 117-5015 Oil Seal Assembly (when installer bottoms against crankshaft, seal assembly, including wearsleeve, is installed in correct location)
- Used with 4C-6375 Locator, 9U-6172 Socket Head Screw (2), 8T-0375 Bolt, and 5P-8247 Washer
- Installer equally distributes installation pressure on edge of seal (prevents damage to edge of seal assembly during assembly, resulting in longer seal life)
- Knurled outside diameter provides better grip for mechanic during oil seal installation
- To use: bolt locator onto crankshaft, put seal assembly in installer, push seal onto crankshaft until installer bottoms out

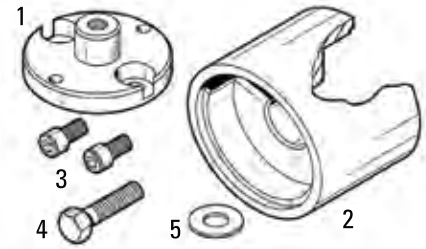

#### Reference

SENR6458, Special Instruction, Disassembly and Assembly of 3046 Engine

Item	Part Number	Description	Size	Small Seal Diameter	Large Seal Diameter
1	4C-6375	Locator	--	--	--
2	127-1591	Rear Oil Seal Installer	--	96 mm (3.78 in)	98.06 mm (3.861 in)
3	9U-6172	Bolt	M12 x 1.25 x 20 mm long (2)	--	--
4	6V-3303	Bolt	M16 x 2 x 60 mm long	--	--
5	4B-5275	Washer	15.875 mm (0.625 in)	--	--
<b>Used With 127-1591:</b>					
1	4C-6375	Locator	--	--	--
3	9U-6172	Bolt	M12 x 1.25 x 20 mm long (2)	--	--
<b>Used With 127-1591 (not shown)</b>					
--	8T-0375	Bolt	--	--	--
--	5P-8247	Hard Washer	--	--	--

## Seal Installer Tools

Model: 3046 Engine

Warranty: Six Months

Item	Part Number	Description
1	4C-6378	Seal Installer Sleeve
2	4C-6376	Installer Stud
3	4C-6377	Installer Washer

- Used to install crankshafts front seal without removing front cover
- Makes installation easier, faster, and prevents damage to seal
- Ensures uniform seal contact around crankshaft — ultimately provides longer seal life



#### Reference

SENR6458, Special Instruction, Disassembly and Assembly of 3046 Engine

# Crankshaft, Main Bearings and Flywheel

Engine Tools

## 367-3534 Seal Installer

Model Usage: C7.1, C6.6, C4.4

Warranty: Six Months

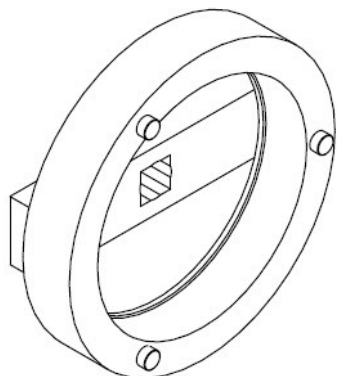

- Used to correctly remove and assemble front crankshaft oil seal

Part Number	Description
367-3534	Seal Installer

## 363-3031 Seal Installer Assembly

Model Usage: C6.4 and 3066 Engines

Warranty: Six Months



- Used to install 324-4223 Seal on front of crankshaft without removing front cover
- Used in place of current 9U-6180 Front Seal Installer Group when installing newly designed seals (using the 9U-6180 will cause seal damage)
- Makes installation easier and prevents damage to seals
- Ensures uniform contact around crankshaft (ultimately provides longer seal life)
- Designed with clearance to fit around protruding parts
- Material: steel

Part Number	Description	Size	Weight
363-3031	Seal Installer Assembly	125 mm (4.9 in) overall diameter x 24.5 mm (.95 in) thick	0.6 kg (1.3 lb)

## Thread Repair Kits

### Essential Tool

Model: 3406, G3406, 3408, G3408, 3508, G3508, 3512, G3512, 3516, and G3516 Engines

Warranty: Six Months

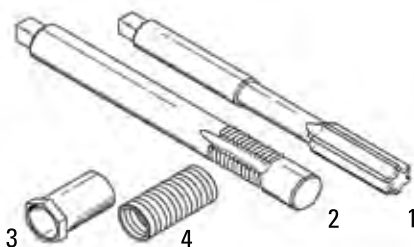

- Used to repair main bearing cap bolt holes
- Repairs bolt hole threads to like-new condition
- Groups are serviced at individual tool level only

### References

SEBF8387, Main Bearing Bolt Hole Repair in 3400 Engines

SEBF8437, Main Bearing Bolt Hole Repair in 3500 Engines

Item	Part Number	Description	Engine Model	1st Ream	2nd Ream	3rd Ream	1st Tap	2nd Tap	Insert Sleeve	Insert
1	178-2349	Reamer	--	--	--	--	--	--	--	--
1	178-2350	Reamer	--	--	--	--	--	--	--	--
1	178-2351	Reamer	--	--	--	--	--	--	--	--
1	178-2462	Reamer	--	--	--	--	--	--	--	--

(Continued)

## Thread Repair Kits (Continued)

### Essential Tool

Model: 3406, G3406, 3408, G3408, 3508, G3508, 3512, G3512, 3516, and G3516 Engines

Warranty: Six Months

Item	Part Number	Description	Engine Model	1st Ream	2nd Ream	3rd Ream	1st Tap	2nd Tap	Insert Sleeve	Insert
2	178-2353	Tap (1-14 UNS)	--	--	--	--	--	--	--	--
2	178-2356	Tap (1-14 UNS)	--	--	--	--	--	--	--	--
2	178-2463	Tap (7/8-16)	--	--	--	--	--	--	--	--
2	178-2465	Tap (7/8-16)	--	--	--	--	--	--	--	--
3	178-2467	Insert, Sleeve	--	--	--	--	--	--	--	--
3	178-2468	Insert, Sleeve	--	--	--	--	--	--	--	--
4	178-2501	Threaded Insert (All 3400 Models)	--	--	--	--	--	--	--	--
4	178-2502	Threaded Insert (All Early 3500 Models)	--	--	--	--	--	--	--	--
4	178-2503	Threaded Insert (All Late 3500 Models)	--	--	--	--	--	--	--	--
<b>Main Bearing Bolt Hole Repair Tools for 3400 and 3500 Engines</b>										
--	203-6594	Thread Repair Kit <sup>1</sup>	All 3400	178-2349	178-2350	178-2351	178-2353	178-2356	178-2467	178-2501
--	203-6597	Thread Repair Kit <sup>1</sup>	Early 3500 3/4 in bolt hole	178-2462	N/A	N/A	178-2463	178-2465	178-2468	178-2502
--	203-6598	Thread Repair Kit <sup>1</sup>	Late 3500 7/8 in bolt hole	178-2351	N/A	N/A	178-2353	178-2356	178-2467	178-2503

<sup>1</sup> Not serviced

## Bearing Cap Tools

Model: 1100, 3100, 3208, D342, D379, D398, D399, 3512, D397, G397, D375, G375, D364, 3500

Warranty: Six Months

- 8S-5131 Adapter used to torque front main bearing cap when oil pump is in place on 1100 and 3100 Series and 3208 Engines
- 1D-5343 Wrench used to remove hollow head screws from main bearing caps on D342 Engines
- 8M-9379 Wrench used to remove main bearing caps without removing pan on D379, D398 and D399 Engines; to apply actual torque indicated by the torque wrench dial reading, insert torque wrench at right angle to 8M-9379 Wrench Assembly
- Discontinued 7F-1709 Wrench used to remove main bearing caps without removing pan on D397, G397, D3867, D375, G375 and D364 Engines



(Continued)

# Crankshaft, Main Bearings and Flywheel

## Bearing Cap Tools (Continued)

Model: 1100, 3100, 3208, D342, D379, D398, D399, 3512, D397, G397, D375, G375, D364, 3500

Warranty: Six Months

- 9U-5023 Main Bearing Wrench used to remove and install crankshaft main bearings on 3500 Family Engines; fits both 12.7 mm (1/2 in) diameter bolt and 19.05 mm (3/4 in) diameter main bearing bolts; can be used through crankshaft access opening in sides of block without removing oil pan when connected to short extension and 3/4 inch drive torque wrench; no longer fits bolts on 17.15 cm (6 3/4 in) bore engines (use 8M-9379 Wrench instead)

Item	Part Number	Description	Socket Size (left end)	Socket Size (right end)	Drive Size
1	8S-5131	Adapter	--	--	--
2	1D-5343	Wrench	--	--	--
3	9U-5023	Main Bearing Wrench	1 5/16 in	1 1/8 in	3/4 in
4	7F-1709	Wrench <sup>1</sup>	--	--	--
5	8M-9379	Wrench	--	--	--

<sup>1</sup> Discontinued

Engine Tools

## 284-5266 Spanner Wrench Assembly

### Essential Tool

Model: C175 Engine

Warranty: Six Months



- Used to remove and install main bearing cap studs
- Used with 1 1/4 inch socket or 1/2 inch square drive wrench

#### Reference

REN7466, C175 Engine Disassembly and Assembly Manual

Part Number	Description	Pin-to-Pin Center Distance
284-5266	Spanner Wrench Assembly	16 mm (0.63 in)
<b>Includes:</b>		
9X-8979	Dowel Pin	--

## 3500 Engine Main Bearing Cap Removal/Installation Tool

Model: All 3500 Engines

Warranty: Six Months

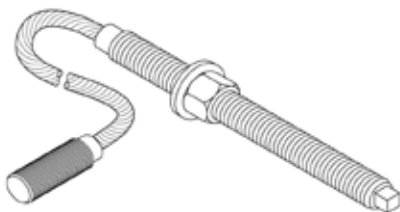

- Used in pairs to remove and install main bearing cap (makes operation much easier)
- Allows one mechanic to remove or install a bearing cap weighing approximately 16 kg (35 lb)
- Flexible wire rope makes it easier to insert tool through engine side covers

#### Application Procedure

1. Loosen all 4 bolts for the main bearing cap.
2. Remove the 2 outer bolts for main bearing cap and replace with tooling.
3. Hand tighten smaller threaded end until tooling bottoms out in cylinder block.
4. Adjust nuts and washers on tooling until washers contact main bearing cap.
5. Remove the 2 remaining inner bolts for main bearing cap.
6. Loosen nuts evenly in order to lower cap. Lower cap to the end of the bolt to gain access to main bearing.
7. Reverse to process for installation.

(Continued)



## 3500 Engine Main Bearing Cap Removal/Installation Tool (Continued)

Model: All 3500 Engines

Warranty: Six Months

Part Number	Use
230-5843	Early 3500 Engines with 3/4 in thd. bearing caps
236-6688	Later 3500 Engines with 7/8 in thd. bearing caps

## 9U-6942 Socket

Model: 3500 Engines

Warranty: Six Months

- Used to remove and install crankshaft counterweight bolts and piston connecting rod bolts
- Used with an impact wrench
- 3/4 inch drive is necessary to obtain the correct bolt torque (1/2 inch drive sockets will not work in this application)
- Socket is specifically designed to provide adequate clearance

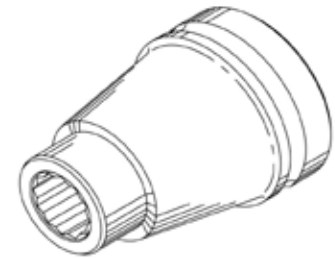

Part Number	Description	Drive Size	Size	Small Diameter
9U-6942	Socket	3/4 in	15.875 mm (5/8 in), 12 point	25 mm (1.0 in)

## FT1794 Crankshaft Main Bearing Removal Tool Group

Model: 3500

Warranty: None

- Used to inspect main bearings of crankshaft on 3500 Series Engines on seagoing vessels for passenger transport; inspection must be done at specific intervals
- Difficult task — because of weight of bearing caps, their tight fit and limited access — is made easier



### Reference

SMHS8331, Special Instruction

## Bearing Removal and Installation Tools

Model: Cat® Engines

Warranty: Six Months

- Used to remove main bearing upper halves quickly and easily in Cat® Engines
- Shank of tool is adjustable to fit angle of crankshaft oil passage



(Continued)

# Crankshaft, Main Bearings and Flywheel

## Bearing Removal and Installation Tools (Continued)

Model: Cat® Engines

Warranty: Six Months

Engine Tools

Bearing Thickness	Part Number
<b>Models: D353, D379, D398, D399 / Bore Size: 159 mm (6.25 in)</b>	
4.55 - 14.76 mm (0.179 - 0.581 in)	2P-5517
<b>Models: D339, D342, D364, D375, D386, D379 / Bore Size: 146 mm (5.75 in)</b>	
4.55 - 14.76 mm (0.179 - 0.581 in)	2P-5517
<b>Models: 4 Cylinder, 90 degree V-8, D343, D346, D348, D349, 1693 / Bore Size: 137 mm (5.40 in)</b>	
4.55 - 14.76 mm (0.179 - 0.581 in)	2P-5517
<b>Models: D326, D337 / Bore Size: 130 mm (5.125 in)</b>	
4.55 - 14.76 mm (0.179 - 0.581 in)	2P-5517
<b>Models: D315, D318, D336, 1673 (early), 1676 / Bore Size: 114 mm (4.50 in)</b>	
4.55 - 14.76 mm (0.179 - 0.581 in)	2P-5517
<b>Model: D311 (early) / Bore Size: 102 mm (4.00)</b>	
4.55 - 14.76 mm (0.179 - 0.581 in)	2P-5517
<b>Model: 3406 / Bore Size: 137 mm (5.40 in)</b>	
2.60 - 3.96 mm (0.1025 - 0.156 in)	2P-5518
<b>Models: D330C, 3304, D333C, 3306, D334, 1674 / Bore Size: 121 mm (4.75 in)</b>	
2.60 - 3.96 mm (0.1025 - 0.156 in)	2P-5518
<b>Models: D330, D333, D320, 1100 and 3100 Series, 3208, 1670, 1673 (Later) / Bore Size: 114 mm (4.00 in)</b>	
2.60 - 3.96 mm (0.1025 - 0.156 in)	2P-5518
<b>Models: D311 (Later), D320 / Bore Size: 102 mm (4.00 in)</b>	
2.60 - 3.96 mm (0.1025 - 0.156 in)	2P-5518

### FT1857 Handle

### FT1907 Bolt, FT1843 Support

Model: D10

Warranty: None

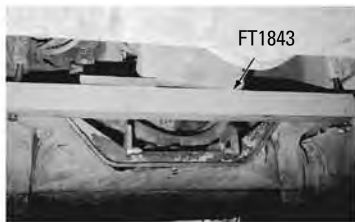

- Fabricated tools for replacing engine bearing without removing engine from chassis
- Save time when replacing main and connecting rod bearings on D10 Tractor by permitting oil pan to be removed without removing engine from chassis (formerly necessary to remove engine to provide clearance for removal of oil pan)

#### Reference

SEHS8432, Special Instruction

## FT1206 Pusher Plate

Model: 16G Motor Graders and 623B Elevating Scrapers

Warranty: None

- Used for engine in-chassis seal and wear sleeve installation



## FT0884 Dimensions to Modify 1P-2321 Puller Assembly

Model: Cat® Engines

Warranty: None

Part Number	Description
1P-2321	Jaw Puller Assembly

- Used to remove oil thrower on engines with ring-type crankshaft rear seal

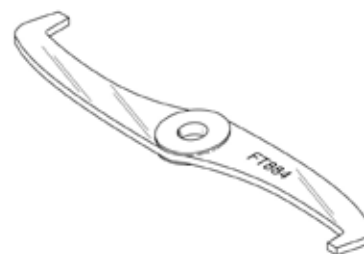

## FT0108 Driver Handle

Model: D10, D10N, D8K, D9H, D9L, 651E, 657E

Warranty: None

- Used with FT0101, FT0102, FT0106, FT0807, and FT0885 Driver Bodies

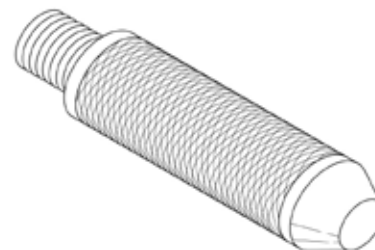

## FT0101 Driver Body

Model: D8K, D9H, D353

Warranty: None

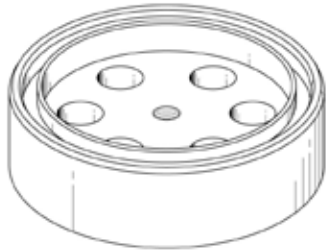

- Used to install rear oil thrower on crankshaft of D353 Engine
- Used with FT0108 Driver Handle
- Material: SAE 4140 steel

## FT0102 Driver Body

Model: D353

Warranty: None

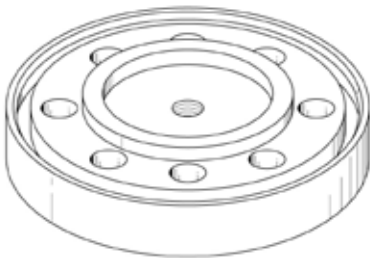

- Used to install front oil thrower on crankshaft of D353 Engine
- Used with FT0108 Driver Handle
- Material: SAE 4140 steel

## FT0106 Driver Body

Model: D343, 1693, 5.4 inch Bore, 619C, 630B, 631B, 632, 657, 666

Warranty: None

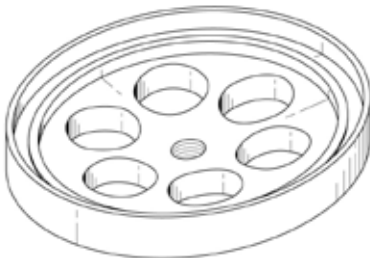

- Used to install oil thrower on crankshaft of D343, 1693 and 4- and 6-cylinder 13.72 cm (5.4 in) bore engines used in 619C, 630B, 631B, 632 Tractors and 657 and 666 Scrapers
- Used with FT0108 Driver Handle
- Material: SAE 4140 steel

## FT0807 Driver Body

Model: D9H

Warranty: None

- Used to install front oil thrower on crankshaft of D353 Engine
- Used with FT0108 Driver Handle
- Material: SAE 1020 steel

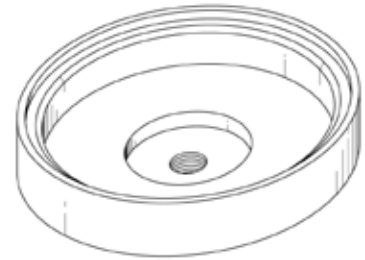

## FT0107 Driver Body

Model: 641, 650, 651, 657, 660, and 666 Tractors, 5.4 inch Bore

Warranty: None

- Used to install oil thrower on crankshaft of 13.72 cm (5.4 in) bore V8 engines

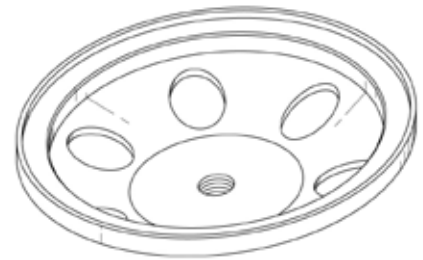

## FT0885 Driver Body

Model: D10, 824C, 834B, 980C, 980F

Warranty: None

- Used to install oil thrower for crankshaft rear seal on 13.72 cm (5.4 in) bore 60° V8 and V12 Engines
- Used with FT0108 Driver Handle
- Material: SAE 4140 steel

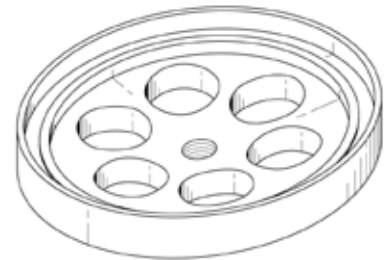

## FT0105 Push Plate

Model: D379B, D398B, D399  
Warranty: None

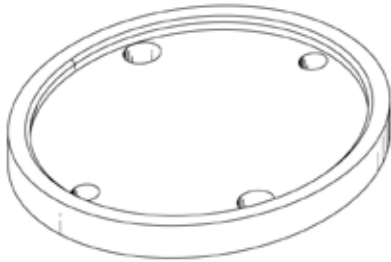

- Used to install oil thrower on crankshaft of D397, D375 and G375 Engines

## 171-7212 Repair Sleeve

Model: 3114, 3116, 3126, 3126B Engines  
Warranty: Six Months

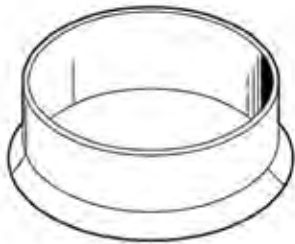

- Used to quickly and easily repair front crankshaft hub damaged by crankshaft seal
- Used with current 5P-6208 Installation Tool
- Used in place of 5P-6188 Repair Sleeve
- Provides wider surface to ensure seal is running completely on sleeve
- Sleeve width: 29.0 mm (1.14 in)

Part Number	Description
171-7212	Wear Sleeve

## Drivers

Model: Cat® Engines  
Warranty: None

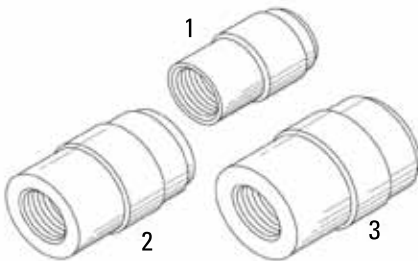

- Used with FT0129, FT0131, and FT0133 Sleeves and FT0144 Handle to install crankshaft plugs and retaining rings for engines listed in chart

Item	Part Number	Model
1	FT0128	619C and 824 Tractor Engines & D326, D337, D343, D336 Engines in all Applications
2	FT0130	641, 650, 651, 657, 660, 666 Tractor Engines
3	FT0132	D353, D379 & D398 Engines in all Applications

## FT0143 Driver

Model: D375 and D397 Engines

Warranty: None

- Used to install crankshaft plugs
- Used with FT0144 Handle
- Material: SAE 4140 steel

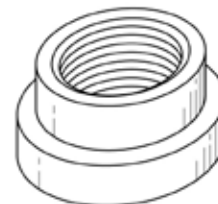

## FT0144 Handle

Model: D7G Engine

Warranty: None

- Used with FT0128, FT0130, FT0132, and FT0143 Drivers for D7G

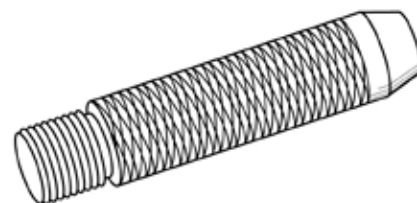

## Sleeves

Model: Cat® Engines

Warranty: None

- Used with FT0128, FT0130, FT0132 Drivers and FT0144 Handle to compress and install crankshaft plugs and retaining rings for engines listed in chart
- Material: SAE 4140 steel

Item	Part Number	Model
1	FT0129	619C and 824 Tractor Engines & D326, D337, D343, D336 Engines in all Applications
2	FT0131	641, 650, 651, 657, 660, 666 Tractor Engines
3	Ft0133	D353, D379 & D398 Engines in all Applications

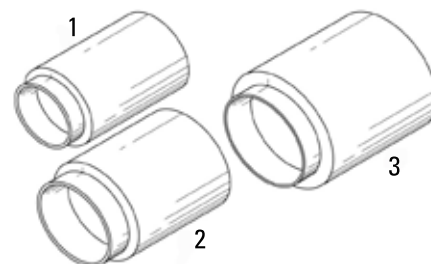

## 332-9511 Bearing Puller Assembly

### Essential Tool

Model: 793F Off-Highway Truck

Warranty: Six Months

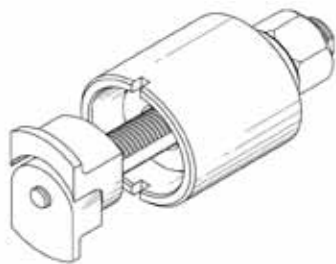

- Used to remove 146-7411 Bearing Sleeve from 146-7404 Cage Assembly in flywheel housing
- Used with 1 5/8 inch socket (dealer supplied)
- Spring-loaded puller tips retract to fit through bearing sleeve then expand to engage bearing sleeve
- Puller tips are hardened to increase strength and durability
- Acme threads on puller rod make removal faster
- Thrust bearing under nut allows easier removal of bearing sleeve
- Not for use with impact tools

Part Number	Description
332-9511	Bearing Puller Assembly

## 373-5840 3500 Liner Insert Air Leak Check Tool

Model: 3500 Engines

Warranty: Six Months

- Used to pressurize the joint and check for air leaks to insure liner insert is fully seated.
- Insert air leak check tool into newly inserted cylinder blocks
- Apply soapy water liberally around the joint on the top of deck
- Attach shop air supply line and set regulator to 137 kPa (20 psi).
- Tool kit includes safety regulator

**Note: Do not use without regulator set to 137 kPa (20 psi)**

Specifications	
Description	Dimensions
Kit	267 x 343 x 83 mm (10.5 x 13.5 x 3.26 in)
Tool	205 x 86.68 mm (8.07 x 3.41 in)

Part Number	Description
373-5840	3500 Liner Insert Air Leak Check Tool



Cylinder Block and Liners

**FT1855 Block Pressure Test Group**

Model: 1100, 3100, 3208

Warranty: None

- Used to check porosity of cylinder block in rebuilt engines (Engine blocks often become pitted on outer wall of cylinder due to improper cooling system maintenance. If pitting becomes severe and cylinders are bored oversize when the engine is rebuilt, there is a possibility that the cylinder wall can have porosity not noticed by visual inspection alone.)

**Application Procedure**

- As part of the test process, put the block on the floor with the flywheel housing end on supporting blocks. Be sure all core and drain plugs are in place.
- Plug the oil cooler outlet
- Install the plate on each cylinder bank
- Fill the cylinder banks with water through the front water passages
- Install the small plates, attach the air pressure regulator, and introduce 100 to 310 kPa (15 to 30 psi) air pressure into the block (if porosity is present, water will either seep or leak into the bores)



Engine Tools

**9U-6274 Compression Test Kit**

Model: 3046, 3054, 3056, 3064, and 3066 Engines

Warranty: Six Months

Item	Part No.	Description
--	9U-6274	Compression Test Kit
<b>Service/Repair Parts</b>		
1.0	9U-6279	Carrying Case
2.0	9U-6277	Pressure Gauge
3.0	9U-6389	Tee Fitting
4.0	9U-6387	Bleed Valve <sup>1</sup>
5.0	9U-6275	Quick Coupler
6.0	9U-6280	Air Connector
7.0	9U-6384	Hose Assembly
8.0	9U-6145	Air Connector
9.0	9U-6390	Bushing
10.0	9U-6276	Quick Coupler
11.0	9U-6391	Quick Coupler
12.0	5C-0249	Plug Cap
13.0	9U-6394	Plug Cap
14.0	9U-6393	Check Valve
15.0	7D-2746	Elbow
16.0	9U-6392	Quick Coupler

- Used to obtain compression pressure for comparison with other cylinders
- Gauge holds reading until released by bleed-off valve
- Flexible hose provides easy viewing angle of pressure gauge
- Air connectors also used to put shop air into combustion chamber while replacing valve springs
- Dual scales on gauge — psi and kPa
- Pressure range: 0 to 7000 kPa (0 to 1000 psi)

Item	Description
Not Shown	NEEG2538 Decal



(Continued)

# Cylinder Block and Liners

## 9U-6274 Compression Test Kit (Continued)

Model: 3046, 3054, 3056, 3064, and 3066 Engines

Warranty: Six Months

Item	Part No.	Description
<b>Not Shown</b>		
--	9U-6385	Foam Block

<sup>1</sup>Part of Cylinder Pressure Group (Gas Engines)

## 193-5859 Cylinder Pressure Tool Kit (Gas Engines)

### Essential Tool

Model: G3300, G3400, G3500, and G3600 Engines

Warranty: Six Months

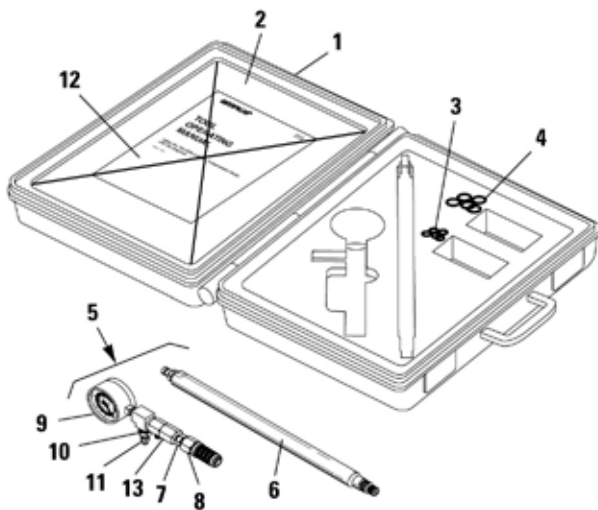

- Used to check cylinder compression
- Low compression reading can be indication of valve guttering, broken valves, broken or worn piston rings, or worn cylinder liners
- Quick way to check for potential engine wear
- Can obtain compression pressure to compare with other cylinders and pressure ratio chart
- 8T-0855 Gauge holds pressure reading until bleed-off valve is released
- Includes easy to use instructions
- Pressure range: 0 to 4000 kPa (0 to 680 psi)

### Reference

NEHS0798, Tool Operating Manual, Using the 193-5859 Cylinder Pressure Tool Kit (All Gas Engines)

Item	Description
5	Cylinder Pressure Group (Gas Engines)
12	NEHS0798 Tool Operating Manual
13	Check Valve <sup>1</sup>
Not Shown	NEEG2911 Decal
<sup>1</sup> Part of Cylinder Pressure Group (Gas Engines)	

Item	Part Number	Description
1	6V-3072	Case - Plastic, NEEG2574 Group Decal on lid (9U-7402 Group)
2	6V-6126	Holder Block (Foam)
3	8L-2786	O-ring (Brown)
4	8M-5127	O-ring (Yellow)
6	192-7130	Adapter Group <sup>1</sup>

Item	Part Number	Description
7	5P-8998	Nipple - Pipe
8	6V-4144	Coupler Assembly (For 42000 kPa)
9	8T-0855	Gauge - Pressure
10	4M-5317	Pipe Reducing Bushing <sup>1</sup>
11	9U-6387	Bleed Valve <sup>1</sup>
--	193-5859	Cylinder Pressure Tool Kit (Gas Engines)

<sup>1</sup>Part of Cylinder Pressure Group (Gas Engines)

## 1P-3565 Chamfering Group

Model: 1100, 3100

Warranty: Six Months

Part Number	Description
1P-3565	Chamfering Group
1P-3564	Abrasive Cone (6)

- Used to break sharp corner at bottom of cylinder bore after honing cylinder bores on 1100 and 3100 Series Engines



## 365-1197 Bore Brush

Model Usage: 3500 Engines

Warranty: Six Months

Part Number	Description
365-1197	Bore Bush

- Used to aid in chamfering the cylinder block liner bores on 3500 engines
- Shaft mounted 241.3 mm (9.5 in) O.D. brush
- Used with a suitable drill or honing machine
- Removes combustion residue and cleans liner bore



## 8S-2269 Ridge Reamer

Model: 1100, 3100, 3204

Warranty: Six Months

Part Number	Description
8S-2269	Ridge Reamer

- Used to remove carbon buildup in cylinder bores
- Service Part: 8S-7202 Cutter Bit (qty. 1)



## Plate Pullers

Model: 3126 Engines  
Warranty: Six Months

129-9196

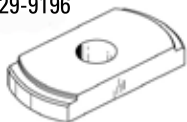

129-9197

- Used to install 107-7604 Cylinder Sleeve in cylinder blocks with damaged cylinder walls
- Used with 1P-0820 Hydraulic Puller Group, 6V-2183 Forcing Screw, 1P-2329 Insert, 1D-5119 Nut, 5H-1504 Washer, and hydraulic pump and hose

### Reference

SEBF8268, Installing a 107-7604 Cylinder Sleeve in 3126 Engines

Part Number	Description
129-9196	Puller Plate (lower)
129-9197	Puller Plate (upper)

## Plate Pullers

Model: 3114 and 3116  
Warranty: Six Months

9U-6007



9U-6008

- Used to install 7C-6208 Cylinder Sleeve into the block
- Used with 1P-0820 Hydraulic Puller, 6V-2183 Forcing Screw, 1P-2329 Insert, 1D-5119 Nut, 5H-1504 Washer, and hydraulic pump and hose

### Reference

SEHS9047, Special Instruction, Installation of 7C-6208 Cylinder Sleeve

Part Number	Description
9U-6008	Plate Puller
9U-6007	Plate Puller

## 9U-6142 Puller Plate

Model: 3064 and 3066 Engines  
Warranty: Six Months



- Used to install cylinder sleeves (both mechanically and hydraulically)
- Used with 1P-0820 Hydraulic Puller Group, 1D-5119 Jam Nut, 5H-1504 Washer, 6V-2183 Forcing Screw, discontinued 1P-2392 Puller Plate, and a hydraulic pump

### Reference

SENR5553, Disassembly and Assembly Manual, 3066 Diesel Engine

Part Number	Description
9U-6142	Puller Plate

## 4C-4377 Stress Plate Group

### 142-2285 Cylinder Head Stress Plate

Model: See below

Warranty: Six Months

Part Number	Description	Model
4C-4377	Stress Plate Group	3114, 3116
142-2285	Cylinder Head Stress Plate	3126B

- Used to hone cylinder bores (necessary tool to properly recondition cylinder bores)
- Allows each cylinder to be honed individually
- Must be installed on cylinder block to simulate assembled cylinder block during stress honing and to measure finished bore dimensions
- Service Part: 200-5214 Spacer

#### References

Service Manual for 3114 and 3116 Engines

SEHS9047, Special Instruction, 3114 and 3116 Engines

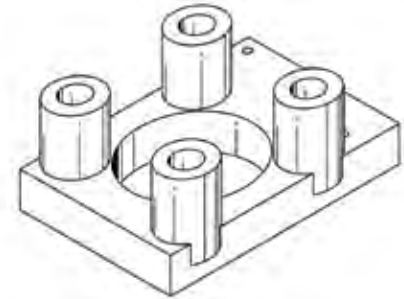

## Cylinder Head Stress Plates

Model: 3114, 3116, and 3126 Engines

Warranty: Six Months

- Used to properly recondition and measure cylinder bores
- Used with 8T-0362 Bolt and 8T-3282 Washer (14 of each required)
- Plate must be installed on cylinder block to simulate cylinder head being assembled onto block
- When plate is installed, cylinder bore is distorted as though cylinder head were installed (plate provides adequate clearance for cylinder hone and measuring tools)
- If plate is not installed during honing, bore will not be round when cylinder head is assembled onto block (this will reduce the life of the overhaul and could affect engine performance)
- Plate is hardened for added strength and durability

Overall size	789 x 215 x 50 mm (31.1 x 8.5 x 2.0 in)
Bore size (3126)	112 mm (4.4 in)
Bore size (3114/3116)	107 mm (4.2 in)
Bolt specifications	M20 x 2.5, 110 mm long

Part Number	Model
125-2064	3126
126-8132	3114, 3116

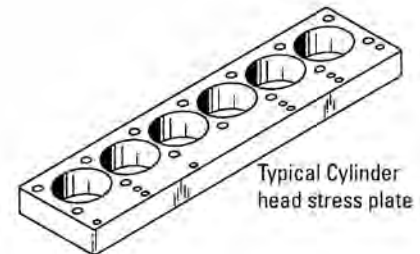

Typical Cylinder head stress plate

## Tools for Reconditioning Cylinder Block Counterbores

Model: Multiple Engine Models

Warranty: Six Months



Engine blocks which develop cracks in the cylinder liner counterbore area can be repaired. The repair consists of machining a new counterbore and installing a liner seat insert. The insert is then machined to standard counterbore depth with the 5P-4175 Counterboring Tool.

The 5P-4175 Counterboring Tool along with the basic tools required for all engines are described below. Refer to the chart for additional tools and the inserts which must be selected for individual engines.

### References

SMHS7600, Special Instruction

SMHS7585, Special Instruction, Use of 5P-4175 Counterboring Tool

Other Special Instructions listed in chart

Item	Description
3	Also includes: Drive Assembly (Part of 5P-1629)
7	No longer available - use 9U-7986 Base and Micrometer Group
11	Installer Assembly (includes parts listed below)
12	Depth Master Gauge
13	Cutter Assembly
14	Cutter Setting Gauge
15	Holder Group (includes parts listed below)
17	Mounting Bolts
18	Liner Seat Insert

Item	Part Number	Description
<b>Basic Tools Required for All Engines</b>		
1	5P-4175	Counterboring Tool Group
2	8H-3127	Bolt - Hex Socket Head
3	5P-1629	Drive Group (Part of 5P-4175)
3	5P-1627	Sprocket Drive (Part of 5P-1629)
3	4B-9806	Screw
4	5P-1631	Chain Assembly (Part of 5P-4175)
5	6V-2120	Sprocket (Part of 5P-4175)
6	5P-1657	Shaft
8	5P-1630	Drive Adapter <sup>1</sup>

Item	Part Number	Description
<b>Basic Tools Required for All Engines (Continued)</b>		
9	5P-1656	Tool Remover Hook
10	5P-1769	Washer (4)
<b>Additional Tools Required for Individual Engines (Refer to Chart for Part Numbers)</b>		
11	5F-9871	Nut
11	4M-6013	Washer
15	6V-4985	Holder Plate
15	6V-4984	Screw
16	5P-1626	Setscrew

<sup>1</sup> Part of 1P-4000 Line Boring Tool Group

## Application Chart for Counterboring Tools

	(18)	(11)	(12)	(13)	(14)	(15)	(17)		
Engine Model	Liner Seat Insert	Installer	Master Depth Gauge	Cutter Assembly	Cutter Setting Gauge	Holder Group	Mounting Bolts	Water Ferrule	Special Instructions
5.4 / 90 V-8	5P-0937	5P-1653	5P-1646	5P-1658	5P-1642	--	1D-4614	--	GMG02442-01
D330 D333 1670 1673	5P-1621	5P-1650	5P-1648	5P-1659	5P-2409	5P-1638	8S-4740	--	GMG02442-01
D330C D333C 1673C 3304 3306	5P-1622	5P-1651	5P-1648	5P-1659	5P-2409	5P-1637	1A-5405 (2)	--	GMG02442-01
D339 D342	5P-6595 <sup>1</sup>	6V-0164, 6V-4987, 6V-4983, 4M-6013, 5F-9871	6V-0156, 6V- 0157	5P-1619	5P-6593, 5P- 6594	5P-1633	1D-4614	5N-8869 <sup>2</sup>	SMHS7049-01, SMHS7982 <sup>2</sup>
D339 D342 D364 D375 D386 D397	5P-1625	--	5P-1647	5P-1619	5P-1643	5P-1633	1D-4614, 9S-1354	--	--
D343 1693	5P-1624	5P-1653	5P-1646	5P-1658	5P-1641	--	1D-4614	--	GMG02442-01
D353 D379	1W-6265 <sup>13</sup>	6V-0165	6V-0156	5P-8606	--	5P-1632	1D-4614	5N-8868	SMHS7221-01
D353 D379 D398 D399	5P-0936	5P-1655	5P-1646	5P-1619	5P-1644	5P-1632	1D-4614	--	GMG02442-01
D398 D399	1W-6267 <sup>14</sup>	6V-4986, 4M-6013, 5F-9871	--	--	--	--	--	--	--
D398 D399	1W-6266 <sup>15</sup>	6V-4983	6V-0157	--	--	--	--	5N-8869	SMHS7982
<b>Spacer Plate Engines, Liner Seat Inserts 8N-6938, 8N-6150 (0.06 in); 8N-6939, 8N-6742 (0.12 in)</b>									
3400 Series	2W-3815	--	6V-0118 (0.06 in)	6V-6191	6V-6189	--	7B-5163	--	SMHS8222
3400 Series	5N-0093	--	8T-0843 (0.10 in)	--	--	--	--	--	--
3500 Series	7W-5949	--	6V-0191	6V-2025	8T-5113	8T-2682	1D-3419	--	SMHS7600
D334 1674 3304 3306 <sup>6</sup>	5P-4174	5P-1651	5P-4176	5P-1659	5P-2409	5P-1637	1D-4588	--	GMG02442-01
D342	8N-6150	--	6V-0118 (0.06 in)	6V-2025	--	5P-1633	9S-1351	--	SMHS7585
D342	8N-6742	--	6V-0191 (0.12 in)	--	--	--	--	--	SMHS7585
D343 1693 D346 D348 D349 <sup>4</sup>	5P-4173	5P-1653	5P-4176	5P-1658	5P-1641	--	1D-4614	--	GMG02442-01
--	8N-6939	--	6V-0191 (0.12 in)	--	--	--	--	--	SMHS7600
--	8N-6938	--	6V-0118 (0.06 in)	6V-2025	--	5P-1632	1D-4614	--	--

<sup>1</sup> Use in case of excessive counterbore cracking<sup>2</sup> D342 only<sup>3</sup> D379-D398 and D399<sup>4</sup> Except discontinued 5S-9500 Block<sup>5</sup> D353 Cylinders 1 and 4<sup>6</sup> Except discontinued 5S-6200 Block

## 9U-7988 Riser Plate Group

Model: 3300 Engines with Spacer Plate

Warranty: Six Months



- Used during salvage operation of liner seats which are cracked or damaged
- Used with 9U-7990 Counterbore Tool Group, 9U-7989 Cutter Plate or 9U-7961 Cutter Plate, and 9U-7992 Cutter Bit
- Eliminates need to remove adjacent cylinder liners during rework procedure

Part Number	Description
9U-7988	Riser Plate Group

### Reference

NEHS0612, Tool Operating Manual

## 9U-7990 Counterbore Tool Group

Model: 3176, 3300 (with spacer plate), and 3406 (with spacer plate) Engines

Warranty: Six Months

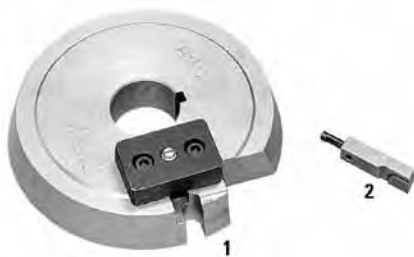

- Used to machine engine block liner seats which are cracked or damaged
- Used with heavy duty electric drill ( 5/8 or 3/4 inch, 300 to 600 RPM, 8 amps or more), 9U-7988 Riser Plate Group (3300 Engine), 9U-7993 Depth Gauge Assembly
- A variety of insert thicknesses are available depending on depth of cut
- Cutter plate is tapered — helps center counterbore tooling in cylinder bore
- Each counterbore operation requires a specific cutter bit and cutter plate (see chart for specific tooling and insert part number)n>- 3176 and 3300 Engines use 9U-7989 Cutter Plate and 9U-7992 Cutter Bitn>- 3406 Engines use 9U-7991 Cutter Plate and 6V-6191 Cutter Bit
- Will not fit 3408 or 3412 Engines

### Reference

NEHS0612, Tool Operating Manual

Item	Part Number	Description	Model
--	9U-7990	Counterbore Tool Group	--
<b>Typical Examples</b>			
1	9U-7989	Cutter Plate	3176 and 3300 Engines
1	9U-7991	Cutter Plate	3406 Engines
2	9U-7992	Cutter Bit	3176 and 3300 Engines
2	6V-6191	Cutter Bit	3406 Engines



## Counterbore Tool Group (Continued)

Model: 3176, 3300 (with spacer plate), and 3406 (with spacer plate) Engines  
 Warranty: Six Months

Not Shown	
Item	Description
Metal Case	Basic Counterbore Tool Group
Case	Base and Micrometer Group



Item <sup>1</sup>	Part Number	Description
1	9U-7985	Basic Counterbore Tool Group (not serviced) <sup>2</sup>
2	9U-7986	Base and Micrometer Group <sup>2</sup>
3	9U-7987	Master Gauge <sup>2</sup>
4	5P-1656	Tool Remover Hook
5	9U-7984	Depth Set Collar
6	1U-7576	Allen Wrench, 5/32 in
6	1U-7575	Allen Wrench, 1/8 in
6	1U-7577	Allen Wrench, 3/16 in

Item <sup>1</sup>	Part Number	Description
7	8T-0207	Bolt M16 x 2 x 100 mm long (3 required)
8	5P-8247	Hard Washer
9	0S-1569	Bolt, 5/8-11 x 4 in long (3 required)
10	5P-1630	Drive Adapter <sup>3</sup>
11	9U-7983	Offset Washer (3 required)
12	5P-8248	Hard Washer
13	0L-1328	Bolt, 3/4-16 x 4 in long (3 required)

<sup>1</sup> Item 1: 9U-7985 Basic Counterbore Tool Group (metal case included, but not shown (part of 1U-6220 Counterbore Group) Not Serviced

<sup>2</sup> Part of 1U-6220 Counterbore

<sup>3</sup> Part of 1P-4000 Line Boring Tool Group

## Machining Dimensions for Cylinder Block Liner Seats

Liner Inserts	Bore Diameter	Depth of Cut
<b>3176 Engine</b>		
105-4203	145.85 mm (5.742 in)	0.772 mm (0.0304 in)
105-4204	145.85 mm (5.742 in)	0.822 mm (0.0324 in)
105-4202	145.85 mm (5.742 in)	0.872 mm (0.0343 in)
104-7903	145.85 mm (5.742 in)	1.555 mm (0.0612 in)
104-7895	145.85 mm (5.742 in)	1.605 mm (0.0632 in)
104-7904	145.85 mm (5.742 in)	1.655 mm (0.0652 in)
104-7905	145.85 mm (5.742 in)	2.660 mm (0.1047 in)
104-7896	145.85 mm (5.742 in)	2.710 mm (0.1067 in)
104-7906	145.85 mm (5.742 in)	2.760 mm (0.1087 in)
<b>3300 engine</b>		
104-5511	144.05 mm (5.671 in)	0.772 mm (0.0304 in)
104-5512	144.05 mm (5.671 in)	0.822 mm (0.0324 in)
104-5513	144.05 mm (5.671 in)	0.872 mm (0.0343 in)
104-5515	144.05 mm (5.671 in)	1.555 mm (0.0612 in)
104-5518	144.05 mm (5.671 in)	1.605 mm (0.0632 in)

Liner Inserts	Bore Diameter	Depth of Cut
<b>3300 engine (Continued)</b>		
104-5522	144.05 mm (5.671 in)	1.655 mm (0.0652 in)
104-5526	144.05 mm (5.671 in)	2.660 mm (0.1047 in)
104-5527	144.05 mm (5.671 in)	2.710 mm (0.1067 in)
104-5528	144.05 mm (5.671 in)	2.760 mm (0.1087 in)
104-5529	144.05 mm (5.671 in)	5.160 mm (0.2031 in)
104-5530	144.05 mm (5.671 in)	5.210 mm (0.2051 in)
104-5531	144.05 mm (5.671 in)	5.260 mm (0.2071 in)
5P-4174	147.32 mm (5.800 in)	5.210 mm (0.2051 in)
<b>3406 Engine</b>		
6I-4361	166.05 mm (6.537 in)	0.772 mm (0.0304 in)
9Y-3368	166.05 mm (6.537 in)	0.822 mm (0.0324 in)
6I-4362	166.05 mm (6.537 in)	0.872 mm (0.0343 in)
6I-4363	166.05 mm (6.537 in)	1.555 mm (0.0612 in)
2W-3815	166.05 mm (6.537 in)	1.605 mm (0.0632 in)
6I-4364	166.05 mm (6.537 in)	1.655 mm (0.0652 in)

(Continued)

## Machining Dimensions for Cylinder Block Liner Seats (Continued)

Liner Inserts	Bore Diameter	Depth of Cut
<b>3406 Engine (Continued)</b>		
6I-4365	166.05 mm (6.537 in)	2.660 mm (0.1047 in)
5N-0093	166.05 mm (6.537 in)	2.710 mm (0.1067 in)
6I-4366	166.05 mm (6.537 in)	2.760 mm (0.1087 in)
101-0524	166.05 mm (6.537 in)	5.160 mm (0.2031 in)

Liner Inserts	Bore Diameter	Depth of Cut
<b>3406 Engine (Continued)</b>		
101-0523	166.05 mm (6.537 in)	5.210 mm (0.2051 in)
101-0525	166.05 mm (6.537 in)	5.260 mm (0.2071 in)
5P-4173	169.29 mm (6.665 in)	5.080 mm (0.2000 in)
108-1068	169.33 mm (6.667 in)	3.302 mm (0.1300 in)

Engine Tools

### 159-9404 Counterbore Tool Group

Model: C-10 and C-12 Engines

Warranty: Six Months

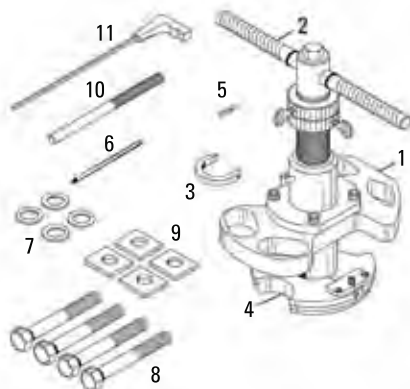

- Used to machine cylinder bore liner seat ledge with special backcut seat design
- Used with 170-6555 Stylus Extension (100 mm [3.94 in]) to measure counterbore depth (not included in group, but requires 9U-7993 Depth Gauge and 8T-0455 Liner Projection Indicator Group)
- Hand operated, easy to use
- 4 shim thicknesses are available to raise liner back to its original height (can be stacked to achieve necessary projection)

#### References

NEHS0733, Tool Operating Manual, 159-9404 Counterbore Tool Group For C-10 and C-12 Engines

SENR6593, Testing and Adjusting C-10/C-12 Truck Engines

Item	Part Number	Description	Size	Quantity
1	159-9393	Basic Machine - Not Serviced	--	--
2	159-9397	T Handle	--	--
3	159-9401	Spacer Block	--	--
4	159-9402	Cutter Plate	--	--
5	159-9403	Cutter Bit	--	--
6	170-6555	Stylus Extension	100 mm (3.94 in)	--
7	5P-8247	Hard Washer	--	4
8	8T-0358	Bolt, M16	--	4
9	159-9395	Square Washer	--	4
10	159-9400	Cutter Plate Wrench	--	--
11	159-9398	Hex Key	--	--
--	159-9404	Counterbore Tool Group	--	--
<b>Not shown</b>				
--	159-9396	Carrying Case	--	--
--	168-7363	Shim	0.22 mm (0.009 in)	--
--	168-7364	Shim	0.25 mm (0.010 in)	--
--	168-7365	Shim	0.28 mm (0.011 in)	--
--	168-7366	Shim	0.50 mm (0.020 in)	--

### 9U-7993 Depth Gauge Assembly

Model: 3300, 3400, and 3176 Engines  
 Warranty: Six Months

- Used to measure actual depth of liner seat counterbore — used during rework procedure of 3176, 3300, and 3400 Engine cylinder blocks
- Used with 9U-7990 Counterbore Tool Group
- Counterbore tool does not have to be removed to measure depth of counterbore — saves time and ensures greater accuracy over conventional means of measuring



**Reference**

NEHS0612, Tool Operating Manual

Part Number	Description
9U-7993	Depth Gauge Assembly

### 1P-4000 Line Boring Tool Group

Model: Multiple Engine Models  
 Warranty: Six Months

- Used with the appropriate centering rings to precision bore semi-finished service main bearing caps
- Hydraulically operated feed mechanism and power drive with a 12.7 mm ( 1/2 in) drill

**References**

SEBF4500, Engine and Component Reconditioning Guide  
 SMHS7606, Special Instruction

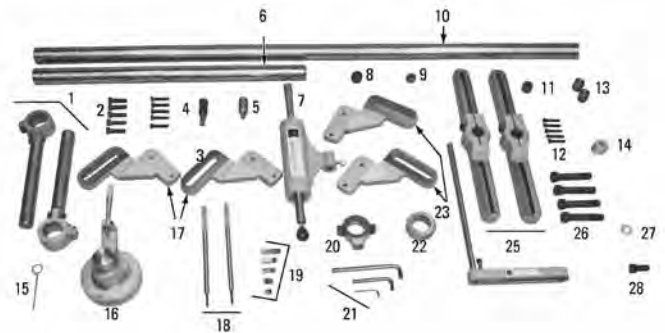

Engine Bore Size	Centering Ring (2 Required) Standard	Centering Ring (2 Required) Oversize
4.50 in (1100, 3100, 3200)	1P-2344	6V-0138
5.40 in — 3400 Series	5P-2381	6V-0142
6.25 in V-Engines	1P-2351	6V-0145
6.70 in 3500 Engine	6V-7836	4C-8564
Not Shown: Box Assembly and Instructions Form SMH7606		

Item	Part Number	Description	Qty.
2	0S-1571	Bolt (English)	5
3	0S-1587	Bolt	5
4	3K-4897	Pin	--
4	5P-1630	Drive Adapter <sup>1</sup>	--
5	1P-2364	Adapter - Line Bore	--
7	5P-2981	Feed Assembly <sup>1</sup>	--
8	5M-5693	Washer	5
9	2S-6160	Washer	5
11	4D-0670	Washer	5
12	1B-9575	Bolt	5
13	1B-4331	Nut	4
14	4B-4283	Washer	8
15	9S-8521	Rod	--
17	1P-2383	Bridge Extension (L.H.)	2
18	1P-2359	Wrench, 5/32 in	--

Item	Part Number	Description	Qty.
18	1P-2360	Wrench, 3/16 in	--
19	1P-2354	Tool Bit, 5/8 in	2
19	1P-2355	Tool Bit, 7/8 in	2
19	1P-2356	Tool Bit, 1 1/4 in	2
19	1P-2357	Tool Bit, 1 1/2 in	2
19	1P-2358	Tool Bit, 2 in	2
20	1P-2362	Holder Assembly, Larger	--
21 <sup>2</sup>	1D-5343	Wrench	--
21	4B-9820	Wrench	--
22	1P-2366	Holder Assembly <sup>1</sup>	--
22	1P-2372	Screw	--
22	2H-0191	Bolt	2
26	1D-4615	Bolt	4
27	4B-4281	Washer	--
28	0S-1589	Bolt	--

(Continued)

# Cylinder Block and Liners

## 1P-4000 Line Boring Tool Group (Continued)

Model: Multiple Engine Models

Warranty: Six Months

Engine Tools

Item	Part Number	Description	Qty.
--	1P-4000	Line Boring Tool Group	--
<b>Item 1, Upright Bearing Assembly (2 each) Consists of:</b> <sup>3</sup>			
1	1L-0509	Socket Head Cap Screw (3/8-16)	4
1	7M-5130	Pin	--
<b>Item 6, Bar Assembly, 31 in Long includes:</b>			
6	1K-6976	Setscrew	2
<b>Item 10, Bar Assembly, 66 in Long includes:</b>			
6	1K-6976	Setscrew	2

Item	Part Number	Description	Qty.
<b>Item 16, Micrometer Bracket Assembly includes:</b> <sup>4</sup>			
--	3L-2540	Screw	--
--	8H-3127	Bolt - Hex Socket Head	--
<b>Item 24, Torsion Bar Assembly includes: Bar, Bracket and:</b>			
--	5S-7003	Screw	--
<b>Item 25, Bridge Assembly includes:</b>			
--	2L-0041	Bolt	--

<sup>1</sup> Part of 1P-4000 Line Boring Tool Group

<sup>2</sup> Includes: 1D-5343, 1/8/in and 5/16 in Hex Wrench, also a 3/8 in Hex Wrench

<sup>3</sup> Also includes: Oiler

<sup>4</sup> Also includes: Holder and Micrometer

## FT1482 Stop Collar Assembly

Model: Multiple Engine Models

Warranty: None



- Used with 1P-4000 Line Boring Tool Group
- Stop collar clamped on shaft of feed mechanism to stop advance of boring bar
- Primarily used for reboring bushing bores which have flat shoulder at bottom

## FT1481 Micrometer Holder

Model: Multiple Engine Models

Warranty: None

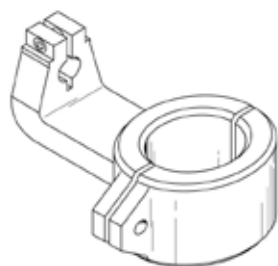

- Saves time in measuring bores when using 1P-4000 Line Boring Tool Group; bore sizes can be measured without removing tool holder from boring bar or disassembling boring bar tool setup to use dial bore gauge
- Used with discontinued 1P-2371 Micrometer; placed directly on boring bar to measure protrusion of carbide tipped tool
- Made from the discontinued 6V-2122 Holder available as service part of discontinued 1P-2370 Micrometer Bracket Assembly

## 6V-7840 Deck Checking Tool Assembly

Model: 518

Warranty: Six Months

- Provides very accurate measurements, which are compared to block specifications, to determine how much of top surface of cylinder block has been machined (when an engine is reconditioned, it is important to know if top deck has been previously machined)

### Reference

SEHS8187, Special Instruction



Part Number	Description	Size
6V-7840	Deck Checking Tool Assembly	--
Service / Repair Parts		
4B-9820	Wrench	1/8 in
6B-7225	Wrench, 3/16 in Hex	3/16 in Hex

## 362-4253 Depth Micrometer Kit

Model: 3400, C15, C-15, C-16, C18, C27, and C32 Engines

Warranty: Six Months

- Used to measure deck height on specific engines
- Used with 362-4250 Tool Kit (Deck Height Measuring Tool)
- 600 mm (24 in) depth micrometer is ideal for measuring large parts
- Includes 400 mm (16 in) moveable bridge attachment
- Precision instrument with resolution of 0.01 mm (.0005 in) provides accurate deck height measurements
- MODE and SET buttons control a range of functions including On/Off, Preset/Hold, Absolute/Relative, and Inch/Metric displays
- One CR2032 lithium battery supplies power for a year or more of normal use
- Kit includes wooden case with provisions for storing depth gauge and moveable bridge attachment
- Includes supplier operating manual

### References

NEHS1102 Tool Operating Manual

SEBF9213, Measuring the Distance to the Top Deck of C15, C-15, C-16, C18, 3400, C27, and C32 Engines, Reuse and Salvage Guidelines

Part Number	Description
362-4253	Depth Gauge

## 362-4250 Tool Kit (Deck Height Measuring Tool)

### Essential Tool

Model: C15, C-15, C16, C-16, C18, C-18, 3400, C27 and C32

Warranty: Six Months

- Used to measure deck height on both V-style and inline engines
- Used with 362-4253 Gauge Kit (order separately)
- End plates are marked for easy identification
- Tool is set up the same way each time to reduce variation, which can cause inaccurate measurements
- For durability, end plates are black oxide coated, and tube is chrome plated

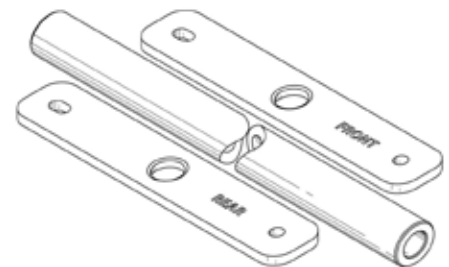

### References

NEHS1102, Tool Operating Manual

SEBF9213, Measuring the distance to the top deck of C15, C-15, C-16, C18, 3400, C27, and C32 Engines

End plates	3.17 kg (7.0 lb) each
Tube	7.03 kg (15.6 lb)

(Continued)

# Cylinder Block and Liners

## 362-4250 Tool Kit (Deck Height Measuring Tool) (Continued)

### Essential Tool

Model: C15, C-15, C16, C-16, C18, C-18, 3400, C27 and C32

Warranty: Six Months

Part Number	Description
362-4250	Tool Kit (Deck Height Measuring Tool)
<b>Service/Repair Parts</b>	
362-4251	Thru-Bar
362-4252	End Plates
<b>Additional Required Tooling (Sold Separately)</b>	
362-4253	Depth Gauge

## 299-5231 Leg Assembly

### Essential Tool

Model: 3600 Gas and Diesel Engines

Warranty: Six Months



- Used to remove cylinder liners (replaces former design)
- Can be used at working pressures up to 34,500 kPa (5,000 psi) which is an increase from 17,250 kPa (2500 psi) of former design
- One-piece design is easier to use (eliminates separate bolt and foot components of former design)
- Serves as a replacement for 6V-7077 Puller Leg and 6V-7076 Foot which are both part of the 3600 Cylinder Liner Removal Tooling

Part Number	Description
299-5231	Leg Assembly

## 5P-8665 Cylinder Liner Puller

Model: Multiple Engine Models

Warranty: Six Months



- Utilizes an impact wrench for fast removal of cylinder liners
- Pulls all liners, most in seconds
- Easy to install and remove
- 6V-4133 Wedge Bracket available separately to be used with 5P-8665 Puller; always use 6V-4133 when removing liners from 3500 Family Engines; it may be used to remove liners in horizontal position from 146.05 mm (5.75 in) bore and 158.75 mm (6.25 in) bore engines; wedge keeps puller feet rigidly positioned under edge of liner
- 1/2 inch impact wrench adequate for job
- Applicable to all Cat® cylinder liners and any other liner up to:  
Diameter: 178 mm (7.0 in)  
Length: 457 mm (18.0 in)

Item	Part Number	Description	Qty.
1	5P-8672	Arm Assembly	2
2	5P-8666	Pin	2
3	5P-8667	Bushing	--

Item	Part Number	Description	Qty.
4	131-6119	Plate Assembly, Top	--
5	5P-8669	Bearing Assembly	--
6	5P-8668	Turning Tool	--

(Continued)

## 5P-8665 Cylinder Liner Puller (Continued)

Model: Multiple Engine Models

Warranty: Six Months

Item	Part Number	Description	Qty.
7	5P-8671	Foot	2
8	6V-4133	Wedge Bracket (see information above)	--
9	2D-4534	Screw	2

Item	Part Number	Description	Qty.
10	8T-5103	Arm Assembly	2
11	131-6118	Lifting Bar	--
12	8T-5104	Spring (Part of Item 4)	2
13	8T-5105	Plunger (Part of Item 4)	2
--	5P-8665	Cylinder Liner Puller	--

## 5P-3570 Cylinder Liner Puller Group Discontinued — Service Parts Available

- Discontinued and replaced by 5P-8665 Cylinder Liner Puller

### Reference

GEG00631, Special Instructions

Item	Description
C	Cylinder Liner Remover — 137.2 mm (5.4 in) Bore Engines Only

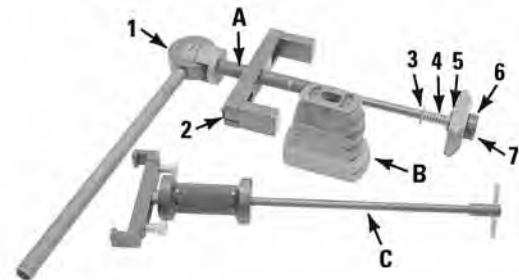

Item	Part Number <sup>1</sup>	Description	Size
<b>Includes the following Service/Repair Parts</b>			
1	5P-3571	Cam and Rod Group	--
2	1J-8499	Washer (2)	--
2	0S-1621	Bolt	--
3	4B-4283	Washer	--
4	5M-6186	Spring	--
5	8F-6462	Washer	--
6	1P-2388	Nut	--

Item	Part Number <sup>1</sup>	Description	Size
<b>Includes the following Service/Repair Parts (Continued)</b>			
7	4B-9806	Screw	--
A	5P-3570	Cylinder Liner Puller Group, Discontinued	--
B	1P-2398	Puller Plate	158.8 mm (6.25 in) Bore
B	1P-2394	Puller Plate	120.7 mm (4.75 in) Bore
B	1P-2396	Puller Plate	137.2 mm (5.4 in) Bore

<sup>1</sup>All part numbers in the table have a Six Month warranty

## 7F-1857 Liner Puller

### Discontinued — Service Parts Available



- Discontinued and replaced by 5P-8665 Cylinder Puller liner

Service / Repair Parts	
Item	Description
3	Handle
11	Swivel

Item	Part Number	Description	Quantity
<b>Service/Repair Parts</b>			
1	1B-4333	Nut	--
2	001-5599	Bearing	--
3	7F-1860	Handle	--
4	5F-7347	Head	--
5	5F-7353	Thrust Washer	--
6	1A-1460	Bolt (1/2 - 13) (fork mounting hardware)	3
7	4B-4280	Washer	3
8	5F-7350	Block	3
9	1B-4330	Nut	--
10	0S-1579	Bolt	--
11	5F-7349	Swivel	--
12	1B-4331	Nut	--

### Adapter Plates for Discontinued 7F-1857 Puller

Model: Multiple Engine Models

Warranty: Six Months

- The hydraulic puller and the different size adapter plates are not included in discontinued 7F-1857 Cylinder Liner Puller Assembly (adapter plates ordered separately as required)

Cylinder Liner Removal — Adapter Plate Selection	
Size	Adapter Plate Part No. (Current)
<b>Adapter Plate Part Number (Former)</b>	
114.3 mm (4.50 in)	5P-7362
<b>Adapter Plate Part Numbers (Current)</b>	
120.7 mm (4.75 in)	1P-2394
137.2 mm (5.40 in)	1P-2398
158.8 mm (6.25 in)	1P-2396



## 8T-0455 Liner Projection Tool Group

Model: Multiple Engine Models

Warranty: Six Months

- Provides easy, accurate way to determine cylinder liner projection and counter-bore depth

### Reference

SMHS7727, Special Instruction

Item	Part Number	Description
1	6V-6045	Case - Plastic, NEEG2061 Accessories Case Decal
1	8T-0453	Block
2	2P-5486	Gauge Block
3	1P-2402	Gauge Body
4	1P-5507	Gauge
5	1P-2403	Dial Indicator
5	1P-5512	Contact Point
6	1P-5513	Contact Point
7	5S-2671	Screw <sup>1</sup>
--	8T-0455	Liner Projection Tool Group

<sup>1</sup> Part of 6D-6680 Tool Group



## 2P-8260 Cylinder Liner Installer Group

Model: Multiple Engine Models

Warranty: Six Months

- Used to install cylinder liners
- Attaches to head bolt or stud, whichever is used, and applies firm, steady pressure, making damage to liner seals less likely

Item	Description
3	Rod
4	Plate

Item	Part Number	Description
1	3H-8538	Pin
2	3B-4615	Cotter Pin
--	2P-8260	Cylinder Liner Installer Group



## FT1543 Plate

Model: 3500

Warranty: None

- Used with 2P-8260 Liner Installer Group to install cylinder liners on all 3500 Family Engines
- Used in place of discontinued 2P-8257 Plate which is not long enough to fit across cylinder liner for 3500 Family Engines
- Can also be used on engines with smaller bore diameters
- Material: SAE 1020 steel

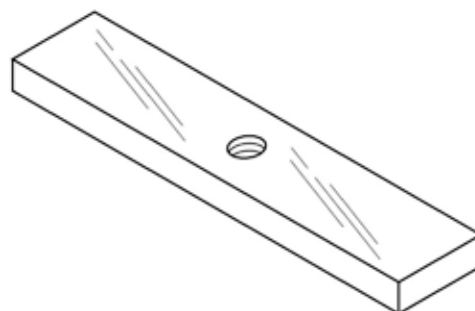

## Cylinder Pack Pullers

Model: See Chart

Warranty: Six Months



Engine Tools

- Used to pull liner, piston and connecting rod, as an assembly, from engines
- Very useful when used for in-frame overhauls because it eliminates need for ridge reaming and dirt generated by reaming
- Each puller should be used with appropriate bridge (see chart) and 1U-6319 Socket which has an extended body to cover length of threaded rod and can be used with impact wrench

### References

SEHS8554, Special Instruction

REN7466, C175 Disassembly and Assembly Manual

SENR1007, Disassembly and Assembly Manual

Cylinder Pack Pullers								
Engine (Bore mm)								
	3300 (120.7 mm)	3176 (125 mm)	C12 (130 mm)	3400 (137 mm / 129.5 mm)	C32 (145 mm)	6.25 (160 mm)	3500 (170 mm)	C175 (175 mm)
Puller	8T-0812	1U-9593	129-6675	6V-9448 <sup>1</sup> 2	373-1438	8T-0811	8T-2686	290-8087
Bridge	--	1U-9897	1U-9897	1U-6317	1U-6317	5F-7347	FT1970	288-9171
Socket	1U-6319	1U-6319	1U-6319	1U-6319	1U-6319	1U-6319	1U-6319	--
Repair Parts								
Full Nut	2J-3506	2J-3506	2J-3506	2J-3506	2J-3506	2J-3506	2J-3506	2J-3506
Hard Washer	5H-1504	5H-1504	5H-1504	5H-1504	5H-1504	5H-1504	5H-1504	5H-1504
Plate	4C-8738	1U-9596	129-6677	4C-8743	373-1440	4C-8747	4C-8751	4C-8751
Threaded Stud	1U-9597	1U-9597	1U-9597	1U-9597	1U-9597	1U-9597	1U-9597	288-9159
Rubber Cup	4C-8736	1U-9594	129-6676	4C-8741	373-1439	4C-8745	4C-8749	417-3451
Segment Group	4C-8739	1U-9598	129-6678	4C-8744	373-1441	--	4C-8752	4C-8752
Base Cone	1U-9825	1U-9825	9U-6630	1U-9825	9U-6630	1U-9825	1U-9825	288-9161
Base Plate	--	--	--	4C-8742	--	4C-8746	4C-8750	288-9162
<sup>1</sup> 6V-9448 also used for 139.7 mm (5.5 in) engine bore size								
<sup>2</sup> Early 6V-9448 Cylinder Pack Pullers have fine thread studs. The only service parts for these pullers are: 1B-4207 Full Nut, 5H-1504 Hard Washer, Threaded Stud made from 6V-4832								

## 322-3564 Puller Group

### Essential Tool

Model: C175 Engines

Warranty: Six Months

European Union compliant, CE marked

- Used to remove and install cylinder liner, piston, and connecting rod as an assembly
- Very useful when used for in-frame overhauls because ridge reaming is not required (eliminates the dirt and grit generated by reaming)
- Puller group should be used with 328-5926 Spacer Plate (provides clearance between cylinder liner lip and head to allow installation of puller group)
- End blocks lock onto cylinder liner lip to secure piston pack to puller group
- Center lift pin assembly threads into piston to prevent it from dropping out of cylinder liner
- Dual lifting eyes allow straight or angled lifting of piston pack for easier removal and installation on engine block

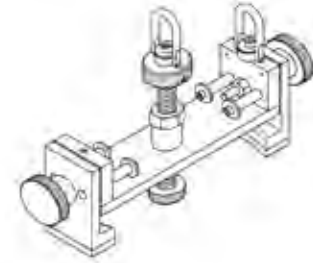

### References

REN7466, C175 Disassembly and Assembly Manual

NEHS1074, Tool Operating Manual, 322-3564 Cylinder Pack Puller

Serviceable Parts	
Part Number	Description
395-0090	Set Knobs (2)

Part Number	Description	Working Load Limit
322-3564	Puller Group	57 kg (125 lb)

## 328-5926 Spacer

Model: C175 Engines

Warranty: Six Months

Part Number	Description
328-5926	Spacer

- Used to position and hold cylinder liner 35 mm (1.4 in) above surface of cylinder block during C175 Piston Pack service
- Used with 290-8087 Puller Group, 288-9171 Bridge, and 322-3564 Puller Group
- Supports cylinder liner in a raised position while other tooling is removed and installed
- Cylinder liner clamps are made from high molecular weight plastic to protect sealing surface of cylinder liner
- Steel bolts thread into existing holes in cylinder block to secure tooling

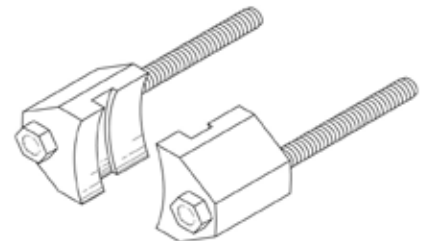

### References

REN7466, C175-16 Generator Set Engine

KENR6052, C175-16 and C175-20 Engines for Caterpillar Built Machines

## Cylinder Liner Puller Plates and Leg

Model: 3054 and 3056 Engines

Warranty: Six Months

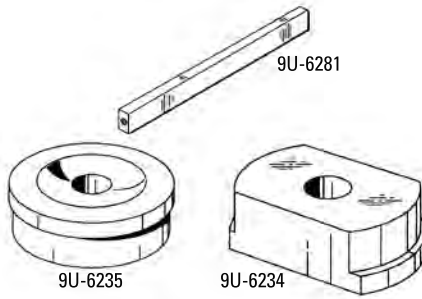

- Used to remove and install cylinder liners
- 9U-6234 Puller Plate used to remove liners, 9U-6235 to install liners
- Legs used between puller plates and additional tooling (three required)
- Liners manually or hydraulically removed (see additional tooling list)

9U-6281 Leg	
Overall length	330 mm (13.0 in)
Internal thread (one end)	1/2-13
Included but Not Serviced:	
9S-7346	Cylinder Assembly (2)

Part Number	Description	Use	Size	Quantity
9U-6281	Leg	--	--	--
9S-7346	Cylinder Assembly	--	--	2
9U-6234	Puller Plate	Remove liners	--	--
9U-6235	Puller Plate	Install liners	--	--
Additional tooling for hydraulic operation				
1D-5119	Jam Nut	--	--	1
1P-2329	Threaded Insert	--	--	1
1A-1460	Bolt (1/2 - 13) (fork mounting hardware)	--	1/2 - 13 x 2 inL	3
1U-9895	Cross block	--	--	--
5F-7347	Head	--	--	--
5H-1504	Washer	--	--	--
5P-8245	Hard Washer	--	--	3
6V-2183	Forcing Screw <sup>1</sup>	--	--	1
Additional tooling for manual operation				
2J-3507	Nut	--	1 - 8 ThreadL	--
8H-0684	Wrench	--	--	--

<sup>1</sup>These parts are used for both hydraulic and manual operation.

## 5P-8709 Piston Cooling Jet Alignment Tool Group

Model: Older Cat® Engines including D353, D377, D398, D899, G379, and G399 only

Warranty: Six Months

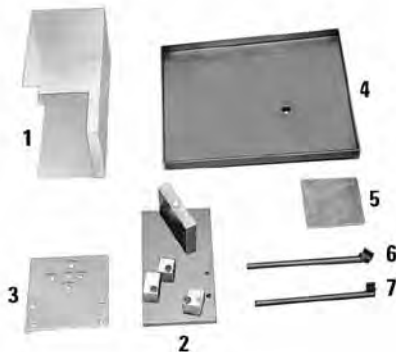

- Used to check the direction of cooling jet spray — used for 5S-1765, 4N-8986, 2N-4541, 4N-9881, and 5L-4262 Piston Cooling Jets only
- Used with fuel injection equipment test stands (FITB, FIETS, and AVM)
- Group has been updated to eliminate non-current bench tooling
- Tooling is required for off-engine testing of piston cooling jets for the engines listed above only
- Parts are serviced separately to reduce dealer cost (no need to purchase tools already in inventory)

### Reference

SMHS7267, Use of 5P-8709 Tool Group

Item	Description	Quantity	Where Used
Required Hardware	Hose Assembly	1	Oil supply #6 (37 degree) x 965.2 mm (38.00 in) long

(Continued)

## 5P-8709 Piston Cooling Jet Alignment Tool Group (Continued)

Model: Older Cat® Engines including D353, D377, D398, D899, G379, and G399 only

Warranty: Six Months

Item	Part Number	Description	Quantity	Where Used
1	5P-8596	Screen	1	with all benches (FITB, FIETS, and AVM)
6	5P-8612	Cooling Jet Adjustment Wrench	1	--
7	5P-8613	Cooling Jet Adjustment Wrench	1	--
--	5P-8709	Piston Cooling Jet Alignment Tool Group	--	--
2	5P-8597	Spray Shield	1	With FITB, FIETS, and AVM
3	5P-8598	Target	1	With FITB, FIETS, and AVM
4	5P-8599	Fixture Assembly	1	With FITB, FIETS, and AVM
5	5P-8600	Oil Return Pan	1	With FITB bench only (Kent Moore)
<b>Required Hardware (not included in group). The following list of hardware is required, but not included as part of the 5P-8709 Piston Cooling Jet Alignment Tool Group. This tooling can be purchased as needed.</b>				
--	6V-9132	Fixture Assembly	1	target/fixture assembly to bench rails
--	6V-9134	Screw Assembly	1	fixture assembly to bench rails (short)
--	6V-9138	Clamp Assembly	1	fixture assembly to rail system
--	0L-1138	Bolt	4	Target to 6V-9132
--	0S-1588	Bolt	2	5P-8599 to 6V-9132
--	032-1267	Connector	1	Oil supply #6 (37 degree) to 1/4-18 NPTF (external)
--	032-1268	Elbow, 90 degree	1	Oil supply #6 (37 degree) to 1/4-18 NPTF (external)
<b>Service/Repair Parts for 5P-8599 Fixture Assembly</b>				
--	3B-7614	Bolt	2	--
--	1L-8793	Bolt	1	--
--	4D-3120	Bolt	1	--
--	7S-6701	Bolt	1	--
--	8H-9208	Dowel	8	--

## FT2736 Alignment Gauge

Model: 3034 Turbocharged Engines

Warranty: None

- Used to align piston cooling jets
- Helps align all four jets in a single operation
- Can also be used to align earlier versions of piston cooling jets
- Material: Perspex

### Application Procedure

1. Put alignment gauge on cylinder block ring dowels
2. Carefully insert steel rods into each jet  
 For current piston cooling jets use 1.30 mm (0.051 in) diameter rods  
 For previous piston cooling jets use 1.20 mm (0.047 in) diameter rods  
 If small diameter rods are not available, use the large diameter rod and machine it to a 1.20 mm (0.047 in) diameter, 8.0 mm (0.13 in) long  
 Rods inserted into jets must protrude through holes in gauge and extend just above top deck of block  
 When rods do not protrude through holes in gauge, carefully bend each affected jet until all rods protrude through gauge
3. Remove gauge and rods

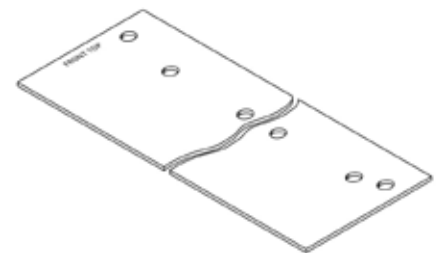

### Reference

SEN5012-02, Service Manual, System Operations Test and Adjustment

(Continued)

## 319-6486 Alignment Tool

### Essential Tool

Model: C4.4 and C6.6 Industrial Engine

Warranty: Six Months



- Used to align front housing on engine block
- Used with three 8T-4185 Bolts (M10 x 50 mm long, dealer supplied) to attach tool to engine block
- Tool fits opening in front housing to accurately position housing during assembly
- Overall size: 77 x 25 mm (3.0 x 1.0 in)

Part Number	Description
319-6486	Alignment Tool

#### Reference

REN9722, Disassembly and Assembly, C6.6 Industrial Engine

## 1U-9593 Cylinder Pack Puller, 1U-9897 Bridge Group and 1U-6319 Socket

Model: 3176

Warranty: Six Months



- 1U-9593 Cylinder Pack Puller used with 1U-9897 Bridge Group to remove cylinder packs or liner only
- 1U-6319 Socket used with 1U-9593 Cylinder Pack Puller; allows use of impact wrench
- 1U-9897 Bridge Group includes 4C-3503 Foot

Part Number	Description
1U-9897	Bridge Group
1U-6319	Socket
1U-9593	Cylinder Pack Puller

#### References

SENR3910, 3176 Service Manual  
SEHS9120, Special Instruction, operation

## 6V-7772 Driver

Model: 3200

Warranty: Six Months



- Used to install piston cooling orifices

Part Number	Description
6V-7772	Driver

## Drivers

Model: 3200

Warranty: Six Months

- Used for installing piston cooling orifices and plugs



Item	Part Number	Description	Model	Use
2	6D-3039	Pin	--	--
3	6V-7771	Driver	3208	Install piston cooling jet plugs
1	6V-7772	Driver	3204 and 3208	Spring pin in end of driver helps hold orifice on tool until it is driven into place

## 198-9113 Seal Installer

### Essential Tool

Model: 3034 Engine

Warranty: Six Months

- Used to install rubber seal in front and rear main bearing cap
- Reduces risk of damage to seal's metal core

### Reference

3034 Engine Service Manual

Part Number	Description	Overall Length	Diameter of Large End	Diameter of Small End
198-9113	Seal Installer	165 mm (6.5 in)	50.8 mm (2 in)	25.4 mm (1 in)

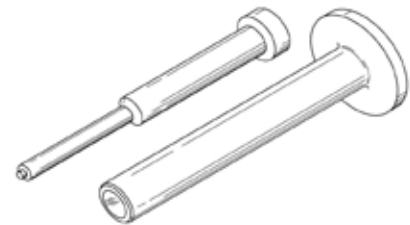

## 5P-8595 Honing Tool Group

Model: 6.25 inch Bore, 6-Cylinder Diesel Engines

Warranty: Six Months

- Used to recondition cylinder liners on 158.75 mm (6.25 in) bore, 6-cylinder diesel engines (D398, D379, D399, D353)
- When later pistons with Keystone rings are installed in earlier engines, honing operation necessary to remove liner wear ridge and produce smooth surface
- FT1371 Holding Fixture holds cylinder liners when honing; provides cradle for 3/4 inch (375 RPM) drill

### Reference

SMHS7220, Special Instruction

(Continued)

# Cylinder Block and Liners

## 5P-8595 Honing Tool Group (Continued)

Model: 6.25 inch Bore, 6-Cylinder Diesel Engines

Warranty: Six Months

Engine Tools

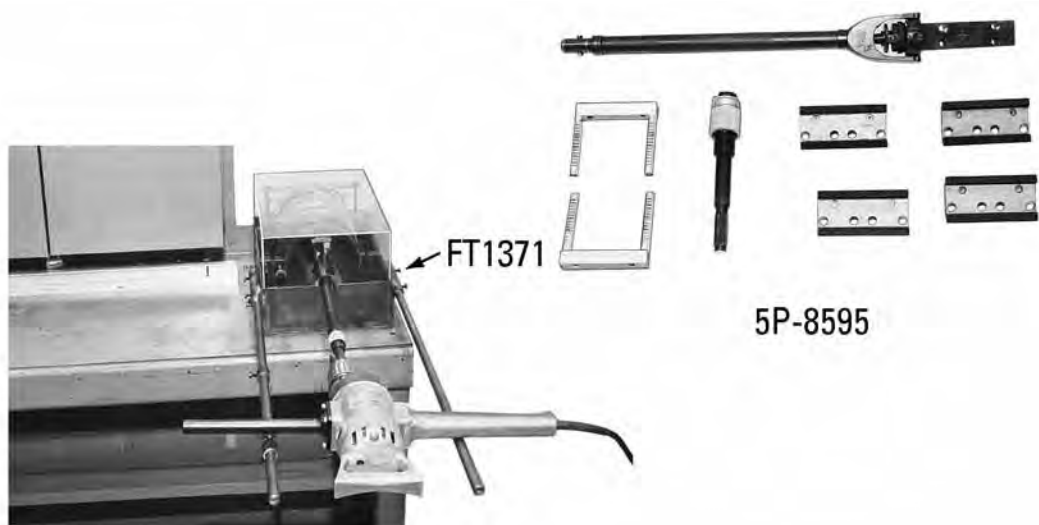

5P-8595

Part Number	Description
5P-8595	Honing Tool Group
<b>Service/Repair Parts</b>	
5P-8592	Stone, 114.03 - 182.88 mm (4.5 - 7.2 in) Diameter (70 Grit)
5P-8593	Stone, 114.03 - 182.88 mm (4.5 - 7.2 in) Diameter (600 Grit)
5P-8591	Holder, Stone
6V-7853	Stone, 101.6 - 142.24 mm (4.0 - 5.6 in) Diameter (70 Grit)

## FT1283 Cylinder Liner Holding Fixture

Model: Multiple Engine Models

Warranty: None



- Holds cylinder liners firmly in position while using Flex-Hone (Flex-Hone powered by 1/2 inch electric drill suspended with cable and pulley arrangement; other end of cable is counterweighted to make honing easier)
- Additional FT1283 Fixture can be set up for cleaning liners after honing



## FT1711 Light Table

Model: Multiple Engine Models

Warranty: None

- Used for inspecting all Cat® cylinder liners
- Fluorescent light source mounted under plexiglass plate
- As many as 6 liners can be placed on fixture at same time
- Adjustable to allow different viewing angles of internal surfaces of liners



## FT1561 Cylinder Liner Storage Cabinet

Model: Multiple Engine Models

Warranty: None

- Used to keep cylinder liners clean after reconditioning
- Size (H x W x D): 2134 x 2159 x 1219 mm (84 x 85 x 48 in)

### References

Engine and Component Reconditioning Guide

SEBF4569, Cylinder Liner Storage Bulletin R-11



## FT1528 Liner Honing Machine

### FT1524 Tub Assembly

Model: Multiple Engine Models

Warranty: None

- Automatically hones and cleans cylinder liners in 10 minutes compared to 1/2 hour for manual operation
- Will recondition 4 cylinder liners at same time and put correct crosshatch pattern on liner bores
- Two FT1524 Tub Assemblies and six cylinder liner plates needed to use FT1528 Liner Honing Machine; cylinder liner plates hold liners with 101.6, 114.3, 120.7, 137.2, 146.1, and 158.8 mm (4.0, 4.5, 4.75, 5.4, 5.75 and 6.25 in) bores; correct cylinder liner plate is put into one of the tubs and liners are installed through holes of plate for honing operation; other tub used for cleaning



## 356-9752 Protective Plug

Model: 3500 Engines

Warranty: Six Months

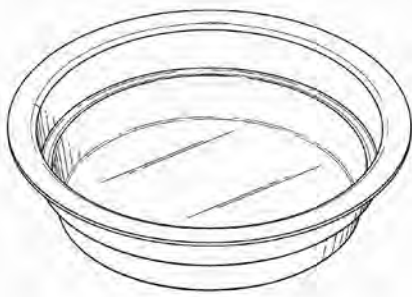

- Used to cover open cylinder bores during service
- Easily and quickly installed and removed
- Covers can be used on 3500 cylinder liners or bare cylinder block bores
- Made of durable plastic
- Stops debris from getting into cylinder block during machining operations.

Part Number	Description
356-9752	Protective Plug

## 366-5984 Installer Assembly

Model Usage: C7.1, C6.6

Warranty: Six Months

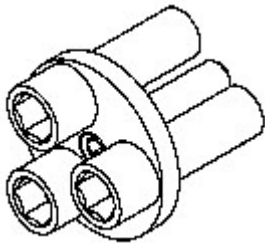

- Used to correctly install crankshaft front oil seal

Specifications	
Dimensions	54X50X50 mm (2.1X2.0X2.0 in)
Weight	0.3 kg (0.7 lb)

Part Number	Description
366-5984	Installer Assembly

## Cylinder Head, Valves and Cam Followers

### Thread Insert Installation Tools

Model: All Engines Models

Warranty: Six Months

- Installation of thread inserts provides relatively easy, inexpensive method of reconditioning cylinder heads in which pre-combustion chamber threads have been damaged

### Reference

SMHS7697, Special Instruction

			(1)	(3)	(5)	(6)	(7)	(8)
Engine Bore Size	Drill Size	Thread Size	Tap	Tap Guide	Pre - Assembly	Sleeve Insert	Nib	
95.25 mm (3.75 in)	1 in			8F-5574		9F-7143		
101.60 mm (4.0 in)	1 in					9F-7143		
107.95 mm (4.25 in)	1 1/8 in		8F-5577	8F-5575		9F-7143	8F-5574	
114.30 mm (4.5 in)	1 1/8 in		8F-5577			9F-7143	8F-5574	
101.60 mm (4.0 in)	51/64 in	3/4 in - 12				9F-7143		
114.30 mm (4.50 in)	51/74 in	3/4 in - 12				9F-7143		
114.30 mm (4.50 in)	28/32 in	7/8 in - 12	9M-6595		9M-6594	9F-7143	9M-6593	9M-6596
114.30 mm (4.50 in) V-8	28/32 in		9M-6595				8S-6400	
120.65 mm (4.75 in) 4-Valve	28/32 in	7/8 in - 12	9M-6595				8S-6400	
120.65 mm (4.75 in) 2-Valve	28/32 in	7/8 in - 12	9M-6595				8S-6400	
130.75 mm (5.12 in)	1 1/8 in		8F-5577			9F-7143	5H-8146	
130.75 mm (5.12 in) Series F	1 in					9F-7143		



# Cylinder Head, Valves and Cam Followers

## Thread Insert Installation Tools (Continued)

Engine Tools

			(1)	(2)	(3)	(4)	(5)	(6)	(7)	(8)
Engine Bore Size	Drill Size	Thread Size	Tap	Pilot	Tap Guide	Drill Winder	Pre - Assembly	Sleeve Insert	Nib	
137.31 mm (5.4 in)	29/32 in	7/8 in - 12	9M-6595		9M-6591	9M-6592	9M-6594	9F-7143	9M-6593	9M-6596
D343, 1693 90° V-8										
137.31 mm (5.4 in)	29/32 in	7/8 in - 12	9M-6595			5P-2418	9M-6594	9F-7143	8S-6400	9M-6596
3400 Series, 137.31 mm (5.4 in)	29/32 in	7/8 in - 12	9M-6595				9M-6594	9F-7143	9M-6593	9M-6596
60° V-8, V-12, V-16, 146.05 mm (5.75 in)	1 1/4 in	1 1/4 in - 12						9F-7143	8F-5575	
146.05 mm (5.75 in)	1 1/8 in	1 1/8 in - 12	8F-5577	1P-3571				9F-7143	5H-8146	
158.75 mm (6.25 in)	1 in	1 in - 12						9F-7143	8S-6402	

### Special Length Heli-Coil Inserts

Thread Size x Length	Description	Part Number
3/4-16 x 1.500 <sup>1</sup>	Insert	6V-9074
5/8-11 x 1.250 <sup>1</sup>	Insert	6V-9076
M8-1.25 x 16 mm <sup>2</sup>	Insert	9U-5177
M16-2 x 32 mm <sup>2</sup>	Insert	9U-5604
M8-1.25 x 16 mm	Tap	4C-8475
5/8-11 x 1.250	Tap	4C-9686
3/4-16 x 1.500	Tap	4C-9702
M16-2 x 32 mm	Tap	4C-9732
3/4-16 x 1.500	Installation Tool	6V-9082
5/8-11 x 1.250	Installation Tool	6V-9083
M8-1.25 x 16 mm	Installation Tool	8T-2790
M16-2 x 32 mm	Installation Tool	8T-2799

<sup>1</sup>Warranty: Manufacturer, One Year

<sup>2</sup>Warranty: Manufacturer, 30-Day

## Valve Guide Drivers and Bushings

Model: All Cat® Diesel Engines, except 1100, 3100, 3208

Warranty: Six Months



- Piloted drivers used to remove and install valve guides
- Most valve guides have flange that prevents driving them past correct depth; guides without flange require a bushing to ensure proper depth

(Continued)

## Valve Guide Drivers and Bushings (Continued)

Model: All Cat® Diesel Engines, except 1100, 3100, 3208

Warranty: Six Months

Valve Guide Drivers and Bushings			
Bore Size	Engine and Engine Application	Driver Part No.	Bushing Part No.
130 mm (5.125 in)	D326, D337	4H-0446	
146 mm (5.75 in)	D342	4H-0446	
146 mm (5.75 in)	D339, D364, D375, D386, D397	4H-0446	
159 mm (6.25 in)	D353, D379, D398, D399	4H-0446	5P-1726
137 mm (5.4 in)	4-Cylinder, D343, G343, 1693, V-8 90°	7M-3975	5P-1728
137 mm (5.4 in)	3406, 3408, 3412		5P-2396
137 mm (5.4 in)	D346, D348, D349 with 9.53 mm (0.375 in) Grooved Guides	7M-3975	5P-1729
114 mm (4.5 in)	1676	7S-5919	
121 mm (4.75 in)	D334, 1674	7S-5919	
121 mm (4.75 in)	D330C, 3304, D333C, 3306		7S-8858 <sup>1</sup>
170 mm (6.69 in)	G3500, 3500	7M-3975	5P-1729
175 mm (6.88 in)	C175	283-0052	284-1503
<sup>1</sup> Includes 9U-7349 Felt Top Marker			

## Valve Guide Driver and Bushing Essential Tool

Model: 3500 Engines

Warranty: Six Months

Item	Part No.	Description
1	334-0409	Valve Guide Driver
2	334-0410	Valve Guide Bushing

- 334-0409 Driver used to remove and install valve guides with flanges
- 334-0410 Bushing used with 334-0409 Driver to install valve guides without flanges to proper depth
- Used on 201-4257, 239-0690, and 239-0691 Cylinder Heads
- Tools have black oxide coating to prevent corrosion
- Heat-treated for added durability

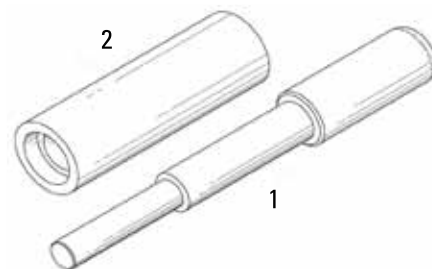

## 124-9057 Guide Collar (Swirl)

Model: 3406C Engines with Swirl Inlet Valve Seats/Inserts

Warranty: Six Months

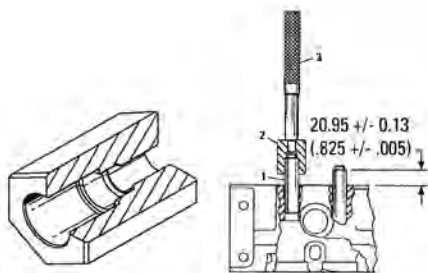

- Used to quickly and accurately install discontinued 121-4317 Valve Guide to proper installation height
- Used with 9U-6895 Valve Guide Driver
- Install valve guide into guide collar, install 9U-6895 Valve Guide Driver into guide collar, and drive it into place (when guide collar contacts surface of cylinder head, valve guide is at proper height)
- Guide collar is heat-treated and plated for durability
- Size: 31.8 mm (1.25 in) hex
- Length: 44.5 mm (1.75 in)

Item	Part Number	Description
1	121-4317	Valve Guide
2	124-9057	Guide Collar
3	9U-6895	Valve Seat Driver

## Valve Guide Installation Tooling

### Essential Tool

Model: 3406C Engines with Swirl Inlet Valve Seats/Inserts

Warranty: Six Months on 328-6001 and 328-6003 Only

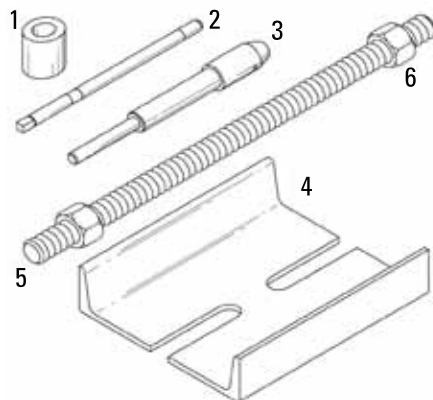

- Used to install 184-5494 and 184-5495 Valve Guides — quickly and accurately
- 328-6001 Driver is hardened (RKW C40-50) for long service life
- FT3123 is made from a modified 7M-3975 Driver Assembly
- FT3124 is made from SAE 1020M steel
- FT3125 is made up of 3/4-10 threaded rod (SAE 1020M) and two 6V-8182 Nuts

### Reference

SEBF9137, Guideline for Reusable Parts and Salvage Operations, Installation and Removal of Valve Guides and Valve Seat Inserts for G3500 Series of Engines

Item	Part Number	Description
3	FT3123	Valve Guide Driver
4	FT3124	Valve Guide C-Channel
5	FT3125	Threaded Rod

Item	Part Number	Description
1	328-6001	Valve Guide Bushing
2	328-6003	Valve Guide Reamer
6	6V-8182	Full Nut, 3/4 in - 10 thd

## 9U-6954 Guide Collar

Model: 3300 Engines  
Warranty: Six Months

Part Number	Description
9U-6954	Guide Collar

- Used to install stepped valve guides to correct height
- Prevents damage to valve guide during installation
- Saves time by automatically controlling guide height
- Height of valve guide above head:  $22.23 \pm 0.25$  mm ( $0.875 \pm 0.010$  in)

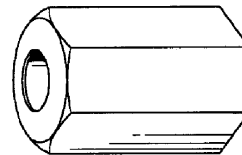

## 149-4008 Valve Guide Collar

Model: 3126B Engines  
Warranty: Six Months

Part Number	Description
149-4008	Valve Guide Collar

- Used to install exhaust valve guides to correct depth in cylinder heads
- Used with 9U-6895 Driver
- Installs valve guides to a consistent depth each time (removes guess work and time consuming measurements)
- Heat-treated for durability
- Overall length: 39.8 mm (1.57 in)
- Outside diameter: 28.5 mm (1.12 in)

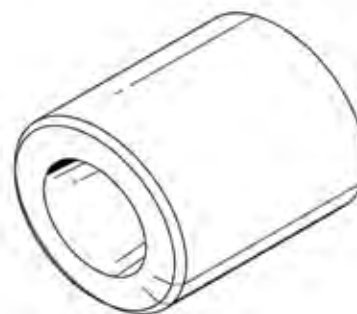

## 9U-6220 Stop Collar

Model: 3054 and 3056 Engines (all SN's)  
Warranty: Six Months

Part Number	Description
9U-6220	Stop Collar

- Used to install valve guides to proper height of 15.10 mm (0.594 in)
- Used with 1U-9169 Guide Driver (7ZK, 6FK, 7AK, 1 ML)
- Used with 157-3722 Guide Driver (5YS, 7MS, 2PW, 3GW)
- Zinc coated to prevent corrosion



## 342-6109 Stop Collar

Model: C9 Engines

Warranty: Six Months

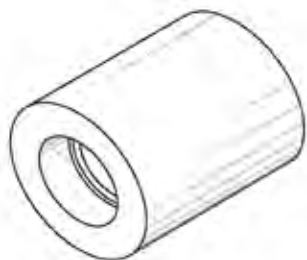

- Used to install 259-5829 Valve Guide to proper height
- Used with 4C-6366 Guide Driver
- Prevents damage to valve guide during installation
- Black oxide coating for corrosion resistance

Part Number	Description
342-6109	Stop Collar

## 157-3722 Valve Guide Driver

Model: 3054, 3056 Engines (serial no. 5YS, 7MS, 2PW, and 3GW)

Warranty: Six Months



- Used to remove and install valve guides
- Used with 9U-6220 Stop Collar
- Heat-treated for added durability

Part Number	Description
157-3722	Guide Driver

Small diameter	8.40 mm (0.331 in)
Larger diameter	12.75 mm (0.502 in)
Overall diameter	19.05 mm (0.750 in)
Overall length	233.5 mm (9.19 in)

## 364-3081 Alignment Guide

Model Usage: G3500 Engines

Warranty: Six Months

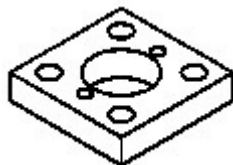

- Provides valve guide alignment during installation procedure
- Provides for the proper installation depth of the valve guides

### Reference:

SEBF9137

Specifications	
Dimensions	120 x 120 x 26 mm (4.72 x 4.72 x 1.02 in)
Weight	2.07 kg (4.56 lbs)
Material	Steel

Part Number	Description
364-3081	Alignment Guide



## 275-2423 Valve Guide Installer

Model: G3408 and G3412 Engines

Warranty: Six Months

Part Number	Description
275-2423	Valve Guide Installer

- Used to install both intake and exhaust valve guides to two different heights (depends on which end of tool is placed against valve guide)
- Used with 9U-7349 Valve Guide Driver
- Inserting driver into end A will install 213-7537 Exhaust Valve Guide to required 32.3 mm (1.27 in) height
- Inserting 9U-7349 Valve Guide Driver into end B will install 213-7536 Intake Valve Guide to required 26.0 mm (1.02 in) height
- Used with a hydraulic press rather than hammer to prevent damage to top of valve guide

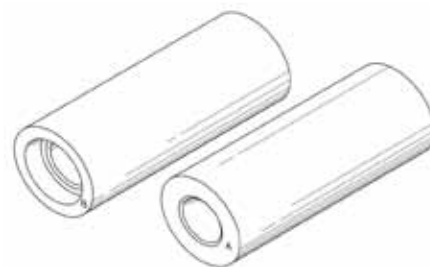

### Reference

SENR6432, Service Manual, Disassembly and Assembly, G3408 & G3412 Engines

## FT1565 Valve Guide Removal and Installation Tool

Model: All Cat® Engines with replaceable valve guides

Warranty: None

- Used with Winona Van Norman PH-7000 Heavy Duty Production Headmaster System and bed extension
- Valve guides hydraulically removed and installed on all Cat® engines that have cylinder heads with replaceable valve guides
- Generally installed on left rear corner of main table
- C-frame assembly of tool has 3 pivot points that give it many positions for use; single-action hydraulic cylinder fastened to this frame and controlled by foot-operated air driven hydraulic pump



### Reference

SEBF4570, Engine and Component Reconditioning Guide Bulletin R-12, "The FT1565 Valve Guide Removal and Installation Tool"

## 6V-7770 Valve Guide Tool Kit

### 6V-7755 Spring Seat Guide

Model: 1100, 3100, 3200

Warranty: Six Months

- Used for installing valve guide sleeves in cylinder heads
- Used with 6V-3095 Boring Fixture and 6V-3108 Boring Fixture Kit
- Valve guides in cylinder heads of 1100, 3100 and 3200 Family Engines not replaceable; when valve guide wears beyond 9.55 mm (0.3760 in) diameter "Use Again" dimension, guide must be reconditioned or complete cylinder head replaced
- 6V-7770 Tool Kit and 6V-7755 Adapter provide tools necessary to bore worn valve guides for installation of 4W-3778 and 4W-3779 Valve Guide Sleeves; tool kit includes driver to install valve guide sleeves and two reamers to size inside diameter of valve guide sleeves to correct dimension



### Reference

SMHS82770-01, Special Instruction

(Continued)

## 6V-7770 Valve Guide Tool Kit (Continued)

### 6V-7755 Spring Seat Guide

Model: 1100, 3100, 3200

Warranty: Six Months

Item	Part Number	Description	Size
1	6V-7770	Valve Guide Kit	--
2	6V-7755	Spring Seat Guide	--
<b>Service/Repair Parts for 6V-7770 Kit, Includes: Line Up Bushing and Drill Bushing</b>			
--	5P-5173	Reamer	9.47 mm (0.373 in)
--	5P-5174	Reamer	9.499 mm (0.374 in)
--	5P-5176	Brush	--
--	6V-7155	Core Drill	--
--	6V-7156	Reamer	12.7 mm (0.500 in)
--	6V-7157	Driver	--
--	6V-7158	Pin	--
<b>Not Shown</b>			
--	9U-5987	Oil	0.236 L (1/2 pint)

## 1U-6685 Guide and Insert Tool Group

Model: 3114, 3116

Warranty: Six Months



- Required for disassembly, assembly, and adjusting of 1.1 liter engine, fuel system, and governor
- Used for valve guide and valve seat removal and installation

#### References

SENR3582, Specification Module  
 SENR3583, System Operation Testing and Adjusting  
 SENR3611, Disassembly and Assembly Manual

Included:
Valve Seat Driver

Part Number	Description
1U-7792	Guide Collar
1U-7793	Guide Driver
1U-7794	Shaft Assembly
1U-7795	Holding Block
1U-7796	Exhaust Extractor
1U-7797	Inlet Extractor
1U-7798	Slide Hammer
1U-8211	Lid Filler Block
6V-7145	Case

## 149-6115 Valve Seat Installer

Model: 3126B Engines

Warranty: Six Months



- Used to install intake and exhaust valve seats
- Used with hydraulic press (valve seats should not be installed using this tool and a hammer)
- Heat-treated for added durability
- To install valve seats, place a 7N-1819 Valve Guide or a piece of suitable tubing over the pin and press into place using hydraulic press (if tubing is used, both ends must be machined squarely)

#### Reference

Engine Service Manual

(Continued)

## 149-6115 Valve Seat Installer (Continued)

Model: 3126B Engines

Warranty: Six Months

Part Number	Description		
149-6115	Valve Seat Installer	Length of tubing	103 mm (4.0 in) minimum
		Small end of driver	intake seats
		Larger end of driver	exhaust seats

## 1U-9654 Tool Group

### Discontinued — Service Parts Available

#### Reference

SENR3910, 3176 Service Manual

All part numbers in the table have a six month warranty

Part Number	Description
1U-9168	Guide Collar
1U-9169	Driver
1U-9170	Driver
1U-9706	Plate
6V-7145	Case
1U-8211	Lid Filler Block
1U-7795	Holding Block
9U-6460	Guide Collar
1U-9654	Tool Group



## 132-4379 Valve Seat Driver (HEUI)

Model: 3114, 3116, and 3126 (HEUI) Engines

Warranty: Six Months

- Used to install 126-0453 Insert (inlet) and 1W-2713 Insert (exhaust) — helps eliminate damage to insert which can occur when a driver is not used
- Long pilot serves as a guide during installation
- Tool ensures that all seats are installed uniformly and to proper depth
- Hardened for added durability — knurled handle provides better grip

Overall tool length	212.0 mm (8.3 in)
Pilot length	81.0 mm (3.2 in)
Pilot diameter	7.9 mm (0.311 in)

Part Number	Description
132-4379	Valve Seat Driver

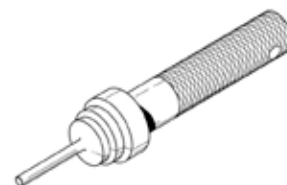

## 9U-6460 Guide Collar

Model: 3176 Engines

Warranty: Six Months

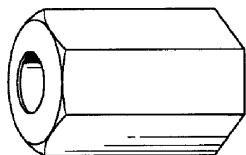

- Used to install stepped valve guide without damage to guide
- Used with 1U-9169 Driver for valve guide removal with discontinued 1U-9654 Tool Group
- Installation height of guide is automatically set (drive guide collar down until it bottoms against top surface of cylinder head)
- Made from high strength steel and heat treated — provides a quality, long-lasting tool
- Bright nickel coating and hex shape provide easy identification

Part Number	Description
9U-6460	Guide Collar

## 9U-6137 Installation Guide Collar

Model: 3064 and 3066 Engines

Warranty: Six Months

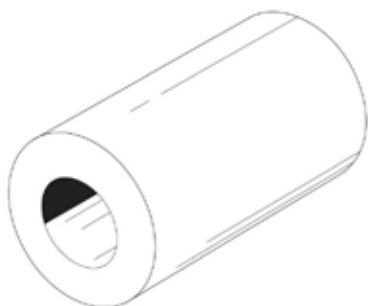

- Used to install valve guides to 17.00 mm (0.669 in) above the top of the cylinder head (quickly and easily installs to correct height)
- Used with 1U-7793 Guide Driver
- Zinc coated to prevent corrosion

Part Number	Description
9U-6137	Installation Guide Collar

### Reference

SENR5553, Service Manual, 3066 Diesel Engines

## 4C-6366 Valve Guide Driver

## 4C-6370 Guide Collar

Model: 3046 Diesel Engine

Warranty: Six Months

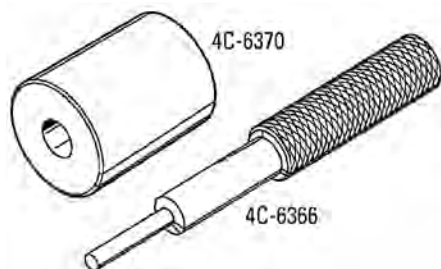

- Used to remove and install valve guide
- Ensures proper height of valve guide
- Knurled handle for better handling
- Guide collar stop height: 14.00 ± 0.10 mm (0.552 ± 0.004 in)

Part Number	Description
4C-6366	Valve Guide Driver
4C-6370	Guide Collar

### Reference

SENR6458, Special Instruction, Disassembly and Assembly of 3046 Engine

## C9.3 Valve Guide and Valve Seat Installer Tools

Model Usage: C9.3

Warranty: Six Months

- Used to install valve guides and seats for C9.3 engines
- Long pilot, valve seat installer, serves as a guide during installation
- Assures seats and guides are installed to proper depths



Specifications			
Part Number	Description	Dimensions	Weight
362-5404	Valve Guide Installer	47 x 25 mm (1.85 x .98 in)	.141 kg (.31 lb)
364-4009	Valve Seat Installer	207 x 42 mm (8.15 x 1.65 in)	.682 kg (1.50 lb)

## 4C-8134 Valve Guide Seal Remover

Model: 3046 Engines

Warranty: Six Months

Part Number	Description
4C-8134	Valve Guide Seal Remover

- Used to remove valve guide seal
- Used with 1U-7600 Slide Hammer
- Tapped hole for slide hammer: 1/2 - 20
- Wrench flat: 19 mm ( 3/4 in)

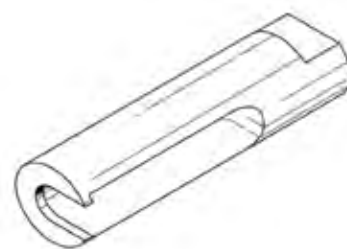

## Valve Guide Ream and Hone Tools

Model: Multiple Engine Models

Warranty: Six Months

Part Number	Description
5P-7289	Mandrel
5P-7290	Sleeve
5P-7291	Stone
5P-7292	Adapter

- Used with head and driver from 1P-7451 Valve Guide Honing Group to ream and hone 12.7 mm (0.5 in) valve guides on D379, D398, D399, G379, G398, G399

**Reference**  
GMG00866



## 1P-7451 Valve Guide Honing Group

Model: Multiple Engine Models

Warranty: Six Months

- Provides precise method for sizing grooved valve guides on D346, D348, D349
- 5P-3536 Valve Guide Gauge Group recommended for measuring all current engine valve guides; however, 1P-7452 Valve Guide Measuring Group for 0.375 mm (0.0014 in) diameter guides still available

**Reference**

SMHS7526, Special Instruction



(Continued)

## 1P-7451 Valve Guide Honing Group (Continued)

Model: Multiple Engine Models

Warranty: Six Months

Item	Part Number	Description
1	1P-7455	Mandrel
2	1P-7454	Stone (7)
3	1P-7457	Truing Sleeve
4	1P-7458	Driver
5	1P-7459	Reamer, 9.42 mm (0.371 in)
6	1P-7452	Valve Guide Measuring Group
7	5P-8615	Honing Oil, 18.9 L (5 gal)
--	1P-7451	Valve Guide Honing Group

## 5P-5170 Valve Guide Knurling Group

Model: 1100, 3100 and 3208

Warranty: Six Months



- Used to recondition cylinder heads and valve guides that are 9.4 to 10 mm (0.371 to 0.375 in) in diameter
- Among models that can be serviced are 1100, 3100 and 3208 Engines; other arbor and reamer sizes adaptable to all current and most non-current Cat® engines are available separately; arbor and reamer sizes not listed can be obtained from K-Line Industries, Inc., 315 Garden Avenue, Holland, Michigan 49423

### Reference

SMHS6747, Special Instruction

Part Number	Description	Size
5P-5170	Valve Guide Knurling Group	--
<b>Consists of:</b>		
5P-5171	Reamer	9.423 mm (0.371 in)
5P-5172	Reamer	9.423 mm (0.371 in)
5P-5173	Reamer	9.47 mm (0.373 in)
5P-5174	Reamer	9.499 mm (0.374 in)
5P-5175	Knurling Arbor	9.423 mm (0.371 in)
5P-5176	Brush	--
5P-5177	Speed Reducer	--
9U-5987	Oil	0.236 L (1/2 pint)

Part Number	Description	Size
<b>Other Arbors and Reamers -- Not Included in 5P-5170 (Sold Separately)</b>		
5P-5188	Knurling Arbor	7.924 mm (0.312 in)
5P-5189	Knurling Arbor	10.312 mm (0.406 in)
5P-5190	Knurling Arbor	12.7 mm (0.500 in)
5P-5179	Reamer	7.874 mm (0.310 in)
5P-5180	Reamer	7.899 mm (0.311 in)
5P-5182	Reamer	10.185 mm (0.401 in)
5P-5184	Reamer	12.573 mm (0.495 in)
5P-5185	Reamer	12.598 mm (0.496 in)
5P-5186	Reamer	12.623 mm (0.497 in)
6V-7156	Reamer	12.7 mm (0.500 in)

## 5P-3536 Valve Guide Gauge Group

Model: Multiple Engine Models

Warranty: Six Months

Part Number	Description
5P-3536	Valve Guide Gauge Group

- Provides method for quickly and accurately measuring all current valve guides for size, taper, and out-of-roundness on D379, D398, D399, G379, G398 and G399
- Contains 3 probes, 3 master ring gauges, and a dial bore gauge
- Probes sized to cover all current valve guides: 7.92 mm (0.312 in), 9.52 mm (0.375 in), and 12.7 mm (0.500 in)
- Each probe long enough to reach completely through longest guide
- Gauge graduated in 0.005 mm (0.0002 in) increments with useable range of 0.38 mm (0.015 in) for each probe



### Reference

GMGO2562, Special Instruction

## Valve Guide Gauges

Model: Cat® Engines

Warranty: Six Months

- Used for quick, accurate checking of valve guide wear limits on Cat® Engines
- Gauges are double-ended to permit checking maximum and minimum valve guide bore dimensions



Valve Guide Gauge Application		
Part Number	Engines In Which Gauge (Red End) is Used to Check Worn Valve Guides	Engines In Which Gauge (Green End) is Used to Check New or Knurled Valve Guides
<b>Valve Guide Gauge Application</b>		
6V-7058	9.55 mm (0.376 in), 1673, 1693, 1100, Series, 3100 Series, 3204 3208, 3304, 3306, D330C, D333C, D342, D343, D346, D348, D349, D353, D379, D398, D399, 137.2 (5.4 in) Bore 90 degree V-8	9.5 mm (0.374 in), 1100 Series, 3100 Series, 3204 and 3208
6V-7068	9.54 mm (0.3755 in), 3406, 3408, 3412, 3508, 3512, 3516, 9.65 mm (0.38 in) intake and exhaust valve	9.460mm (0.3725 in), 3304, 3306, 3406, 3408, 3412
261-3687	12.672 mm (0.498 in), 3508, 3512, 3516, 12.7 mm (0.5 in) exhaust valves only	12.594 mm (0.4958 in)
6V-7895	12.775 mm (0.503 in), D353, D379, D398, D399	--
4C-9734	8.08 mm (0.318 in), 3114, 3116	8.035 mm (0.316 in)

## 5S-1330 Pneumatic Valve Spring Compressor

Model: All Engines except 3600

Warranty: Six Months



- Timesaver when removing and installing valve keepers
- Discontinued 5S-1326 Special Adapter used in place of regular jaws for servicing D343 and 1693 Engines

Item	Part Number	Description	Size
--	5S-1330	Pneumatic Valve Spring Compressor	--
1	5S-1325	Frame	--
3	5S-1326	Cylinder Special Adapter	--
2	5S-1323	Cylinder	--
4	5S-1327	Jaw	[25.4 mm (1 in) - 44.45 mm (1 1/4 in) Cap]
5	5S-1328	Jaw	[28.57 mm (1 1/8 in) - 50.8 mm (2 in) Cap]
6	5S-1329	Jaw	[38.1 mm (1 1/2 in) - 63.5 mm (2 1/2 in) Cap]

## 1P-3527 Valve Spring Compressor

Model: 1.1, 1.2, 3126B, 3200, 3300, 3400

Warranty: Six Months



- Quick and easy way to remove valve springs
- Hand operated
- An alternative to the 5S-1330 Pneumatic Spring Compressor when compressed air is not available
- Cylinder head must be off the engine

Part Number	Description
1P-3527	Valve Spring Compressor

## 6V-4062 Injector Spring Compressor

Model: 3500 Marine

Warranty: Six Months

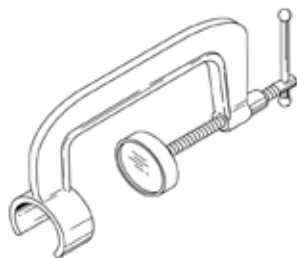

- Used to check fuel injection — will move freely under its own weight
- Rack movement needs to be checked in several positions

Part Number	Description
6V-4062	Injector Spring Compressor

### Reference

SEN4693, 3516 Marine Disassembly and Assembly



## 7F-4292 Valve Spring Compressor Group

Model: 1100, 3100, 3208

Warranty: Six Months

- Used to remove and install valve springs manually
- Engines with recessed valve spring chambers require 7M-3976 Adapter; 1100 and 3100 Series and 3208 Engines require 8S-2277 Adapter Assembly

Part Number	Description
7F-4292	Valve Spring Compressor Group
7F-4291	Compressor Assembly
8S-2277	Adapter Assembly (1100, 3100 Series, 3208) (Not part of 7F-4292)
7M-3976	Adapter (D343, 1693) (Not part of 7F-4292)



## 9U-6144 Adapter Assembly

Model: 3064 and 3066 Engines

Warranty: Six Months

Part Number	Description
9U-6144	Adapter Assembly

- Used for manual removal of valve springs (adapts 7F-4292 Compressor Group to 3064 and 3066 Engines)
- Can also be used with 9U-6145 Air Connector to remove valve springs without removing head

### Reference

SEN5553, Service Manual, 3066 Diesel Engines



## 9U-6145 Air Connector

Model: 3064 and 3066 Engines

Warranty: Six Months

- Used to replace valve springs and guide seals without removing the head (allows on-engine replacement)
- Air connector fits into cylinder head injector port to put shop air into combustion chamber (prevents valve from dropping into cylinder bore)
- Used with 7F-4292 Valve Spring Compressor and 9U-6144 Compressor Adapter
- Part of 9U-6274 Compression Test Kit (connector can be ordered separately if the test kit is not needed)

### Reference

SEN5553, Service Manual, 3306 Diesel Engines

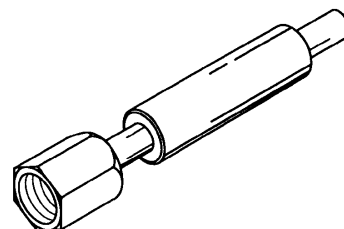

(Continued)

# Cylinder Head, Valves and Cam Followers

## 9U-6145 Air Connector (Continued)

Model: 3064 and 3066 Engines

Warranty: Six Months

Overall length	153 mm (6.0 in)
Small end diameter	7.15 mm (0.281 in)
Body diameter	16.75 mm (0.659 in)
Air connection	1/4-18 NPTF
Hex head	19.0 mm (0.75 in)

Part Number	Description
9U-6145	Air Connector

Engine Tools

## 268-1971 Compression Adapter

### Essential Tool

Model: C6.6 Engines

Warranty: None



- Used to adapt compression tester

Part Number	Description
268-1971	Compression Adapter

## 1U-9347 Valve Spring Compressor Group

Model: 3400

Warranty: Six Months

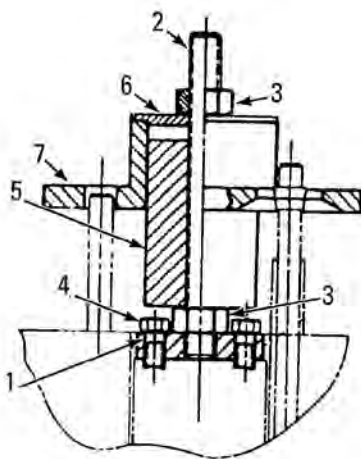

- Used to remove and install valve springs on 3400 Family Engines equipped with earlier-style fuel nozzle adapter or new-style adapter
- Compresses all valve springs on one cylinder at same time; safely retains them while the valve locks are removed
- Can be used with cylinder head on or off engine
- Saves time, especially for on-engine applications
- Applications: replacing valve stem seals and springs, removing springs to service the unit injector sleeve

### Reference

SEHS9032, Special Instruction

### Earlier Style Nozzle Adapters

Item	Description
1	Adapter Plate
2	Stud
5	Collar
6	Spacer
7	Plate Assembly

Item	Part Number	Description	Quantity
3	1D-4719	Nut	2
4	0S-1618	Bolt	2
--	1U-9347	Valve Spring Compressor Group	--

## Later Style Nozzle Adapters

Item	Description
1	Plate Assembly
2	Adapter Assembly
3	Adapter Assembly

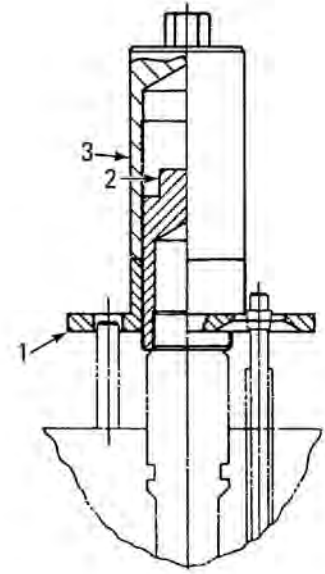

## Service Tools for Jacobs Vehicle Systems (Jake Brake®)

### Essential Tool

Model: C-10, C-12, 3176/B, 3306B/C, 3406B/C/E Truck Engines

Warranty: Six Months

Engine Tools

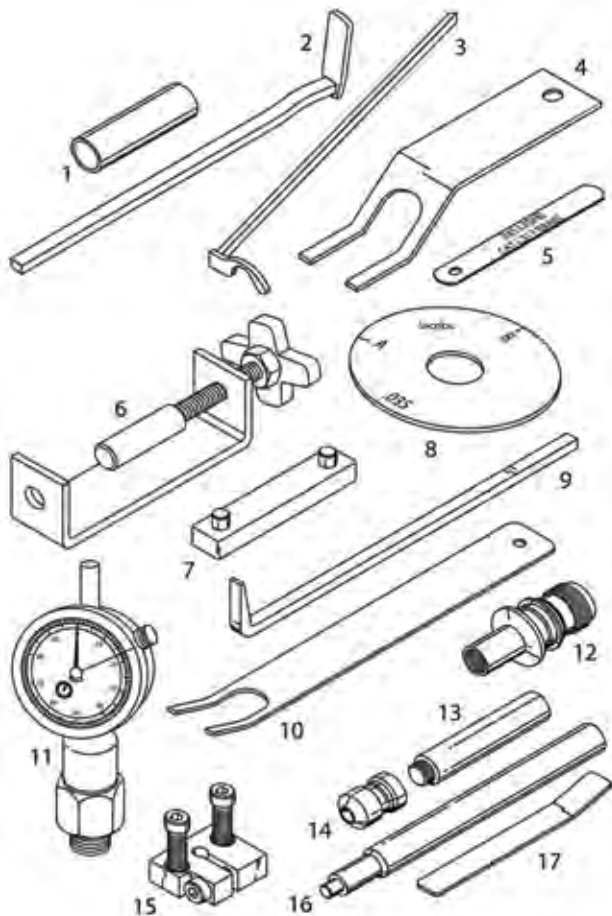

- Used to quickly and accurately install or service Jake Brake Units on Cat® On-Highway Truck Engines and articulated trucks
- All tools are genuine OEM parts
- Tools can be ordered individually
- 149-6112 Trigger Upgrade Kit allows rotation of dial indicator in early trigger sets kits
- 143-6452 Fuel Line Protective Kit includes caps to seal fuel lines from contamination during a retrofit (for 3406B and C Engines only)
- 149-6111 Oil Pressure Test Kit includes a solenoid valve o-ring pack (pack not available separately). Individual O-rings are available by ordering 2U-1493 Seal Ring, Lower, 2U-1492 Seal Ring, Middle, and 143-6642 Seal Ring, Upper.

Item	Part Number	Description
1	149-6108	Installation Support Tool <sup>1</sup>
2	134-2836	Feeler Gauge, 1.70 mm (0.067 in) <sup>1</sup>
2	149-0054	Adjusting Gauge, 0.457 mm (0.018 in) <sup>1</sup>
2	149-6105	Adjusting Gauge, 2.03 mm (0.08 in) <sup>1</sup>
2	149-0050	Adjusting Gauge, 2.29 mm (0.09 in) <sup>1</sup>
3	149-0059	S/P Adjusting Gauge, 3.43 mm (0.135 in) <sup>1</sup>
4	149-0053	Feeler Gauge, 1.52 mm (0.06 in) <sup>1</sup>
4	149-0052	Feeler Gauge, 1.78 mm (0.07 in) <sup>1</sup>
5	149-0055	Feeler Gauge, 0.508 mm (0.02 in) <sup>1</sup>

Item	Part Number	Description
5	149-6114	Feeler Gauge, 0.635 mm (0.025 in) <sup>1</sup>
5	149-0056	Feeler Gauge, 1.14 mm (0.045 in) <sup>1</sup>
5	150-7227	Feeler Gauge, 1.02 mm (0.04 in) <sup>1</sup>
5	149-0058	Feeler Gauge, 1.27 mm (0.05 in) <sup>1</sup>
6	134-2837	Slave Piston Tool
7	149-6113	Bridge Set Gauge Package <sup>1</sup>
8	149-0114	Slave Lash Gauge, 0.889 mm (0.035 in) <sup>1</sup>
9	149-6110	M/P Holding Wedge <sup>2</sup>
10	149-0051	Feeler Gauge, 2.03 mm (0.08 in) <sup>1</sup>
11	149-6109	Trigger Adjusting Group with Dial Indicator

(Continued)

## Service Tools for Jacobs Vehicle Systems (Jake Brake®) (Continued)

### Essential Tool

Model: C-10, C-12, 3176/B, 3306B/C, 3406B/C/E Truck Engines

Warranty: Six Months

Item	Part Number	Description
12	150-3618	Pressure Test Solenoid Valve <sup>3</sup>
13	150-3617	Pressure Test Adapter <sup>3</sup>
14	150-3616	C/V Pressure Test Body <sup>3</sup>
15	149-6104	Dowel Extractor <sup>1</sup>
16	150-3619	C/V Cover Removal Tool <sup>3</sup>
17	149-0028	Feeler Gauge, 0.686 mm (0.027 in) <sup>1</sup>
17	149-0049	Feeler Gauge, 0.762 mm (0.03 in) <sup>1</sup>
17	155-5238	Feeler Gauge, 0.838 mm (0.033 in) <sup>1</sup>

Item	Part Number	Description
17	155-5239	Feeler Gauge, 0.94 mm (0.037 in) <sup>1</sup>
<b>Not shown</b>		
--	149-6106	Cat® Tool Kit
--	149-6107	Tool Box <sup>1</sup>
--	149-6111	Oil Pressure Test Kit
--	149-6112	Trigger Adjusting Group Upgrade Kit
--	143-6452	Fuel Line Protective Kit <sup>1</sup>
--	150-7145	Pressure Gauge 0 - 700 kPa (0 - 101.5 psi) <sup>3</sup>

<sup>1</sup>Part of 149-6106 Tool Kit-Cat®

<sup>2</sup>Part of 149-6109 Trigger Adjusting Group

<sup>3</sup>Part of 149-6111 Oil Pressure Test Kit

### FT1566 Valve Spring Compressor

Model: All Cat® Engines

Warranty: None

- Used to pneumatically compress valve springs to remove and install valves
- FT drawing has instructions for building 2 units: one for attachment to cylinder head disassembly bench and the other, which has a longer column, to be attached to Winona Van Norman head bench
- Spring compressor arm has 2 pivot joints permitting operator to compress several valve springs before moving cylinder head
- At end of arm is 50 mm (2 in) air cylinder with a 152 mm (6 in) stroke, 1245 N (280 lb) of force with shop air at 620 kPa (90 psi)
- 3-position, lever-activated valve controls movement of cylinder rod



### FT1886 Valve Spring Compressor Group

Model: 3204 and 3208

Warranty: None

- Makes valve spring replacement faster and easier in applications where clearances are limited

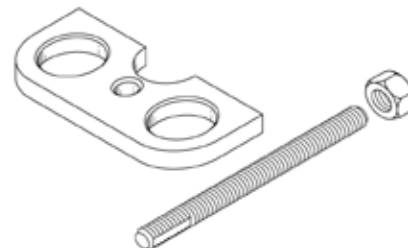

## 228-3610 Feeler Gauge (C15)

## 235-0032 Lash Gauge (C13)

Model: C13 and C15 Engines

Warranty: Six Months

- Used to set variable valve actuators

Part Number	Description
228-3610	Feeler Gauge
235-0032	Lash Gauge

## 241-0124 Spring Compressor Group

Model: 3500 Engines

Warranty: Six Months

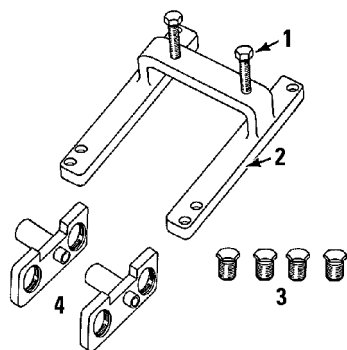

- Functions as valve spring compressor for on-engine removal of valve springs
- Compresses all four springs simultaneously
- Functions as valve depressor when plugs are installed in bridges; depressing valves allows borescope inspection of valve faces and seats
- Easy installation — requires removal of rocker shaft and rocker arms only
- Operable by one person
- Mounting bolts included

Item	Part Number	Description	Size	Quantity
1	0S-1587	Bolt	1/2-13 x 1 3/4 in	2
2	241-0121	Mounting Bracket	--	1
3	4T-5657	Plug	--	4
4	241-0122	Spring Compressor Bridge	--	2

## Valve Spring Compressor Group for C13 Engine

Model: C13 Engine

Warranty: Six Months

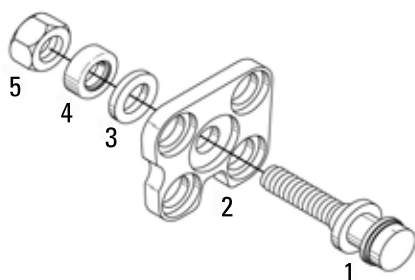

- Used to remove and install valve springs of C13 Engine
- Compresses all valve springs on one cylinder at same time; holds them in place while valve locks are removed
- Can be used with cylinder head on or off-engine
- Saves time, especially for on-engine applications

Item	Part Number	Description
<b>235-0518 Valve Spring Compressor Group</b>		
1	9U-7548	Compressor Base
2	267-5716	Compressor Plate
3	2S-0115	Washer
4	1U-8826	Thrust Bearing
5	2J-3506	Nut

## Valve Spring Compressor Group for 3176 Engine

Model: 3176 Engine  
Warranty: Six Months

Item	Part Number	Description
<b>4C-6726 Valve Spring Compressor Group</b>		
1	9U-7548	Compressor Base
2	4C-6727	Compressor Plate
3	2S-0115	Washer
4	1U-8826	Thrust Bearing
5	2J-3506	Nut

- Used to remove and install valve springs of 3176 Engine
- Compresses all valve springs on one cylinder at same time; holds them in place while valve locks are removed
- Can be used with cylinder head on or off-engine
- Saves time, especially for on-engine applications

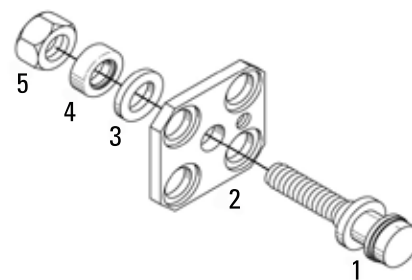

## Valve Spring Compressor Group for 3406E Engine

Model: 3406E Engine  
Warranty: Six Months

- Used to remove and install valve springs of 3406E Engine
- Compresses all valve springs on one cylinder at same time; holds them in place while valve locks are removed
- Can be used with cylinder head on or off-engine
- Saves time, especially for on-engine applications

### References

SENR5580, Service Manual  
SENR6421, Service Manual Module, Disassembly and Assembly 3406E Engines

Item	Part Number	Description
<b>9U-7241 Valve Spring Compressor Group</b>		
1	1U-7639	Compressor Base
2	9U-7242	Compressor Plate
3	5P-8248	Hard Washer
4	1U-8826	Thrust Bearing
5	2J-3506	Nut
6	0L-1143	Bolt

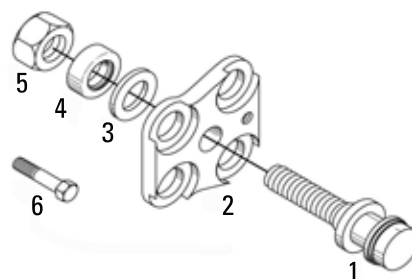

## 9U-6195 Valve Spring Compressor Group

Model: 3054 and 3056 Engines  
Warranty: Six Months

- Used to manually remove and install valve springs without removing cylinder head
- Used with 9U-6280 Air Connector to hold valves in position

### Reference

SENR5547, Service Module in SENR5555 Service Manual

Item	Description
3	Nut

Item	Part Number	Description
1	9U-6193	Compressor Assembly
2	9U-6194	Stud
3	9U-6196	Nut
--	9U-6195	Valve Spring Compressor Group

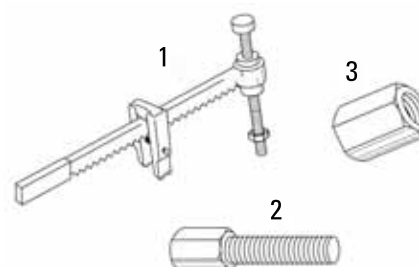

## 276-1221 Valve Spring Assembly

### Essential Tool

Model: C6.6 Engines

Warranty: Six Months

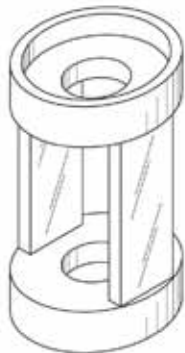

- Used to remove valve spring without removing cylinder head
- Used with 9U-6195 Valve Spring Compressor Group

Part No.	Description
276-1221	Valve Spring Assembly

## 8T-2660 Compressor Group

### Essential Tool

Model: All 3600 Diesel Engines

Warranty: Six Months

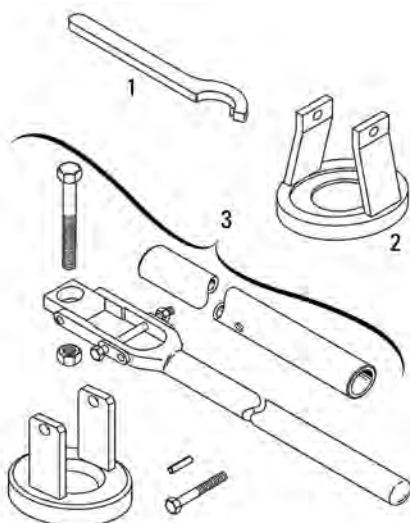

- Used to remove and install valve springs, plus prevents damage to the valve rotator
- Spring removal from HFO engines require 8T-2660 along with 167-3972 Spanner Wrench and 167-3974 Mounting Cap Assembly

Item	Description
3	Extension Handle
3	Lever Group

Item	Part Number	Description	Size
1	167-3972	Spanner Wrench (HFO Only) (not included)	--
2	167-3974	Mounting Cap Assembly (HFO Only) (not included)	--
3	2A-4781	Bolt	1/4-20 x 69.9 mm (2.75 in) long
3	8F-6350	Bolt	3/8-16 x 203 mm (8.0 in) long
3	8T-2660	Compressor Group	--
3	9S-8752	Nut - Full (3/8 - 16)	3/8-16
3	8T-2661	Spring Compressor Adapter	--
3	6H-3956	Spring Pin	4.76 x 25.4 mm (0.187 x 1.0 in) long



## 8S-2263 Valve Spring Tester

Model: All Engines  
Warranty: Six Months

Part Number	Description
8S-2263	Valve Spring Tester

- Provides fast, accurate testing for old valve springs which should be tested before installing in reconditioned head
- Scale graduated in newtons and has maximum capacity of 1555 N (350 lb)
- Similar to 4C-9496 Spring Tester with maximum test force of 1200 lb for testing larger springs



## 5S-1322 Valve Keeper Inserter

Model: All Cat® Engines  
Warranty: Six Months

Part Number	Description
5S-1322	Valve Keeper Inserter

- Used with the 7F-4292 Compressor to install valve keepers



## Valve Seat Extractor Tooling Essential Tool

Model: 3500 Engines  
Warranty: Six Months

Item	Part Number	Description
1	317-3841	Valve Seat Extractor
2	317-3843	Shaft Assembly

- Used to remove valve seat inserts on 3500 Engines
- Used with 166-7441 Valve Seat Extractor Tool Group
- Both parts are hardened for strength and long service life
- Tools are black oxide coated for corrosion resistance

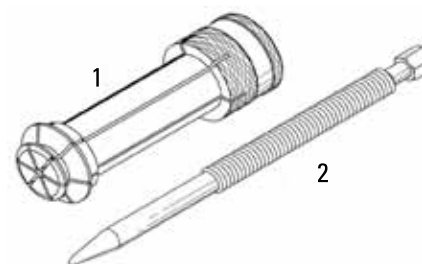

### Reference

SMHS7935, Special Instruction

## 166-7441 Valve Seat Extractor Tool Group

Model: All Cat® Engines except 3600

Warranty: Six Months



- Replaces discontinued 6V-4805 Valve Seat Extractor Tool Group and discontinued 9S-3080 Valve Seat Insert Puller Group
- Used to remove valve seat inserts on all Cat® engines
- Uses only 4 extractors and employs different method of insert removal, which causes less damage to the extractors
- Provides grinder to groove inside of insert to make insert removal easier with extractor
- 165-5647 has notched 47.63 mm (1.875 in) diameter for easy removal of G3500 swirl-type inserts

### Reference

SMHS7935, Special Instruction

Item	Description
10	Plate Assembly

Item	Part Number	Description	Size
1	6V-4801	Stone	--
--	166-7741	Valve Seat Extractor Tool Group	--
2	6V-4802	Wheel	--
3	165-5647	Extractor	22.23 mm (0.875 in), 34.93 mm (1.375 in), 47.63 mm (1.875 in) plus swirl inserts
4	6V-4194	Extractor	25.4 mm (1.0 in), 38.1 mm (1.5 in), 50.8 mm (2.0 in)
5	6V-4195	Extractor	28.58 mm (1.125 in), 41.28 mm (1.625 in), 53.98 mm (2.125 in)

Item	Part Number	Description	Size
6	6V-4196	Extractor	31.75 mm (1.25 in), 44.45 mm (1.75 in), 57.15 mm (2.25 in)
7	222-3074	Medium Mini Die Grinder, requires 4C-3689 Collar	--
8	6V-4199	Lifting Bracket	--
9	6V-4197	Base Group	--
11	6V-4803	Thrust Bearing (Part of 6V-4804)	--
12	6V-4804	Handle Assembly	--
13	6V-4192	Shaft Assembly	--

## Valve Seat Extractors

Model: 3054 and 3056 Engines

Warranty: Six Months

- Used with 9S-3095 Handle Assembly to remove valve seat insert

Item	Part No.	Description	Dimension (A, B)	Extractor Length	Use
1	9U-6396	Extractor (Inlet)	49.5 mm (1.95 in)	102 mm (4 in)	Remove inlet valve seat
2	9U-6397	Extractor (Exhaust)	44.7 mm (1.76 in)	102 mm (4 in)	Remove exhaust valve seat

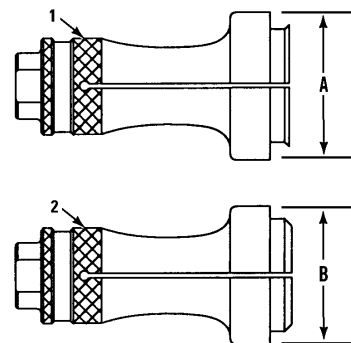

## 4C-6371 Valve Seat Driver, Inlet

## 4C-6372 Valve Seat Driver, Exhaust

Model: 3046 Diesel Engine

Warranty: Six Months

Part Number	Description
4C-6371	Valve Seat Driver, Inlet
4C-6372	Valve Seat Driver, Exhaust

- Used to install valve seats
- Serves as a guide to properly align seat during installation — saves time and reduces chance of damage
- Knurled handle for better handling

### Reference

SEN6458, Special Instruction, Disassembly and Assembly of 3046 Engine



## Valve Seat Drivers

### Essential Tool

Model: Cat® 3400 Gas Engine

Warranty: Six Months

- Used to install valve seats
- Used with suitable mallet
- Serves as a guide to properly align valve seat during installation — reduces assembly time and helps prevent possible damage
- Knurled handle for better grip and handling
- Hardened (RKW C40-45) for durability and long service life

### Reference

SEN6568, G3408C and G3412C Engines, Disassembly and Assembly

Part Number	Description	Use
343-6646	Valve Seat Driver, Exhaust	Installs 212-0938 Exhaust Valve Seat
343-6647	Valve Seat Driver, Inlet	Installs 214-3286 Inlet Valve Seat

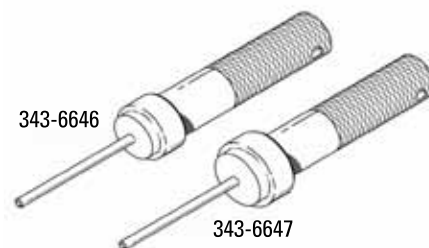

## 366-5728 G3500 Engine Valve Guide Installer

Model Usage: G3500 Engines with water cooled inserts

Warranty: Six Months

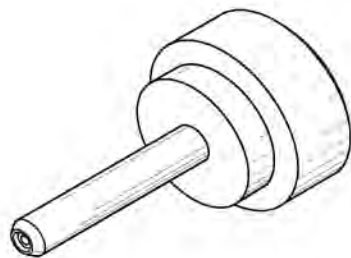

- Used to install intake and exhaust valve guides on G3500 engines with water cooled inserts, used during rework process
- This is a shorter version of the 9U-6184 that enables more control over the installation process
- Made from steel and hardened for durability

Part Number	Description	Size	Weight
366-5728	Valve Guide Installer	Overall dimensions: 42.4 mm (1.67 in) diameter X 76 mm (2.99 in) long	0.27 kg (.6 lb)

## 362-9108 G3500 Engine Valve Seat Installer

Model Usage: G3500 Engines with water cooled inserts

Warranty: Six Months

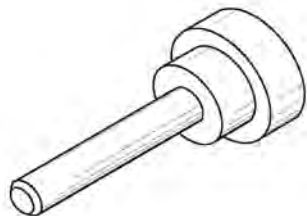

- Used in rework process for installing valve seats in G3500 engines with water cooled inserts
- Helps guide valve seat during installation (makes correct installation easier and faster)
- Made from steel and hardened for durability

Part Number	Description	Size	Weight
362-9108	Valve Seat Driver	Overall dimensions: 59.5 mm (2.34 in) diameter x 140 mm (5.51 in) long	Weight: 0.84 (1.85 lb)

## 9S-3080 Valve Seat Insert Puller Group Discontinued — Service Parts Available



### Reference

GMG02114, Special Instruction

Item	Part Number <sup>1</sup>	Description
--	9S-3080	Valve Seat Insert Puller Group
1	9S-3081	Extractor
1	9S-3082	Extractor
1	9S-3084	Extractor
1	9S-3085	Extractor
1	9S-3086	Extractor
1	9S-3087	Extractor
1	9S-3089	Extractor
2	9S-3095	Handle Assembly
3	9S-3097	Shaft (part of 9S-3095)

<sup>1</sup>All part numbers in the table have a six month warranty

## 130-1449 Valve Seat Puller Group

Model: All 3600 and G3600 Engines

Warranty: Six Months

- Replaces discontinued 9U-5099 Valve Seat Puller Group (9U-5099 includes 9U-5096 Bridge Assembly)
- Used to remove intake and exhaust valve seat inserts
- Used with 6V-3160 Hydraulic Cylinder for faster, safer removal
- A 9U-5098 Threaded Insert, part of 130-1449, can be used to adapt discontinued 6V-7047 Hydraulic Cylinder (130-1449 includes 9U-5096 Bridge Assembly)
- Overall length: 337 mm (13.3 in)
- Overall width: 140 mm (5.5 in)

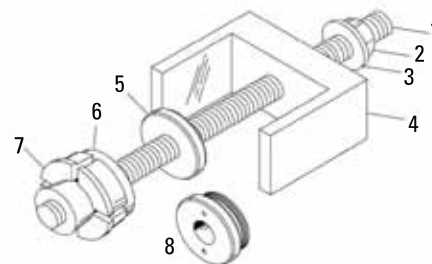

### Reference

SEN3594, Disassembly and Assembly, 3612 and 3616 Engines

Item	Part Number	Description
1	128-6759	Stud and Cone Assembly
2	1A-1935	Nut
3	3K-5234	Washer (3)
4	9U-5096	Bridge Assembly
5	128-6761	Nut
6	9U-5097	Shoulder Screw
7	157-2882	Expander
8	9U-5098	Insert
--	130-1449	Valve Seat Puller Group
<b>Not Shown</b>		
6	9U-5095	Plate

## Valve Seat and Valve Guide Tooling

Model: 3034 Engines

Warranty: Six Months

- Used to remove and install valve guides and valve seats

### Reference

SEN5013, 3034 Engine Disassembly and Assembly Manual

Valve Seat and Valve Guide Removal and Installation Tooling			
Item	Part Number	Description	Use
1	FT2714	Intake Valve Seat Driver	Install 45 degree intake valve seat
2	FT2715	Exhaust Valve Seat Driver	Install 45 degree exhaust valve seat
3	FT2716	Valve Guide Driver	Remove and install valve guide
4	FT2717	Valve Guide Stop Collar	Install valve guide to correct depth

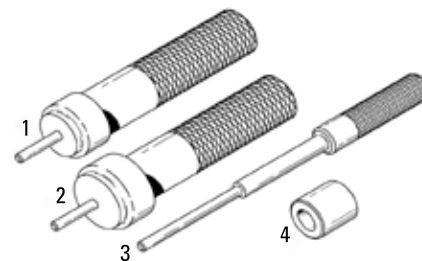

## C4.2 and C6.4 Valve Guide Install and Removal Tools

Model Usage: C4.2, C6.4

Warranty: Six Months



- Used to install remove and install valve guides during rework process
- Made of hardened steel and black oxide coated for durability and corrosion resistance

### Reference

KENR8105

Part Number	Description	Dimensions	Weight
<b>Specifications</b>			
384-8861	Valve Guide Remover	20.0 x 230.0 mm (.78 x 9.05 in)	.33 kg (.73 lb)
384-8862	Valve Guide Installer	20.0 x 120.0 mm (.78 x 4.72 in)	.28 kg (.62 lb)

## C6.4 Valve Seat Install Tools

Model Usage: C6.4

Warranty: Six Months



- Used to install intake and exhaust valve seats during rework process
- Made of hardened steel and black oxide coated for durability and corrosion resistance

### Reference

KENR8106

<b>Specifications</b>			
Part Number	Description	Dimensions	Weight
384-8859	Intake Seat Installer	30.0 x 185.0 mm (1.18 x 7.28 in)	.65 kg (1.43 lb)
384-8860	Exhaust Seat Installer	37.9 x 185.5 mm (1.50 x 7.30 in)	.71 kg (1.56 lb)

## 125-6185 Swirl Valve Seat Driver

## 125-6186 Swirl Valve Seat Driver Guide

Model: 3406C Engines With Swirl Valve Seat/Insert

Warranty: Six Months

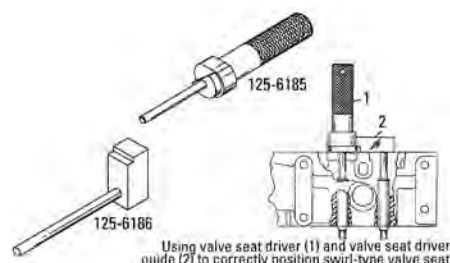

- Used to install 115-2358 Inlet Swirl Valve Seat/Insert
- Using both tools quickly and correctly positions valve seat
- Valve seat locates on shoulder of valve seat driver (will only locate in one position)
- Valve seat driver guide correctly positions the radial location of valve seat driver (positions the seat in the correct radial location in cylinder head)
- Valve seat driver locates in valve guide bore — valve seat driver guide locates in valve guide bore of adjacent valve port
- Seat driver and guide are hardened and plated for durability
- Overall length of seal driver: 252 mm (9.9 in)
- Overall size of valve seat driver guide: 61 x 155 mm (2.4 x 6.1 in)

Part Number	Description
125-6185	Swirl Valve Seat Driver
125-6186	Swirl Valve Seat Driver Guide

## 9U-6176 Valve Seat Driver

## 9U-6177 Exhaust Driver Plate

Model: 3064 and 3066 Engines

Warranty: Six Months

- Used to install both intake and exhaust valve seats
- Correctly aligns insert during installation
- Knurled handle for better handling

### Reference

SENR5553, Service Manual, 3066 Diesel Engines

Item	Part Number	Description	Length	Major Outside Diameter
1	9U-6176	Valve Seat Driver	207 mm (8.1 in)	45.6 mm (1.79 in)
2	9U-6177	Driver Plate Exhaust	--	38.1 mm (1.50 in)

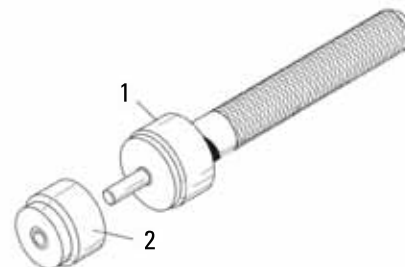

## Valve Seat Drivers

Model: 3054 and 3056 Engines (SN's 7ZK, 6FK, 7AK, 1ML)

Warranty: Six Months

- Used to install 30° and 45° intake and exhaust valve seats
- Helps guide seat during installation (makes correct installation easier and faster)
- 9U-6183 used for 45° intake seats, 9U-6184 for 45° exhaust seats, 9U-6185 for 30° intake seats
- Knurled handle for better grip (zinc coated for corrosion resistance)
- Overall length: 203.0 mm (8.0 in)
- Outside major diameter: 42.4 to 51.2 mm (1.7 to 2.0 in)

### References

SENR5547, Service Manual

SENR5555, Service Manual

Part Number	Description
9U-6183	Valve Seat Driver
9U-6184	Valve Seat Driver
9U-6185	Valve Seat Driver



## Valve Seat Drivers

Model: 3054 and 3056 Engines with 5YS, 7MS, 2PW, and 3GW Serial Numbers

Warranty: Six Months

- Used to install valve seats in new engines with unfinished valve seats and guides
- Installs both 30 and 45 degree seats
- Knurled handle provides better grip

Part Number	Description	Overall Length	Major Outside Diameter
157-3717	Valve Seat Driver (Intake)	227 mm (9 in)	44.9 mm (1.77 in)
157-3716	Valve Seat Driver (Exhaust)	227 mm (9 in)	42.8 mm (1.69 in)



## Valve Seat Drivers

Model: 3406E Engines

Warranty: Six Months



- Used to install valve seat inserts
- Serves as guide for proper alignment of insert during installation
- Knurled handle for better grip (zinc coated for corrosion resistance)

### Reference

SENR6421, Special Instruction

Part Number	Description	Overall Length	Major Outside Diameter
9U-6897	Valve Seat Driver (Inlet)	254 mm (10 in)	47.4 mm (1.87 in)
9U-6898	Valve Seat Driver (Exhaust)	254 mm (10 in)	42.5 mm (1.67 in)

## 8T-0859 Valve Seat Depth Gauge

Model: 1100, 3100, 3200

Warranty: Six Months



- Used to quickly determine valve seat depth on cylinder heads
- During cylinder head reconditioning, valve seat faces usually grind moving face of valve seat deeper into cylinder head; as material is removed from seat face, valve stem length on spring side of cylinder head increases, reducing distance valve spring is compressed and at same time reducing spring load; with use of straight edge across top of valve guide, gauges used to determine if valve seat depth is within limits

Part Number	Detail
8T-0859	Gauge, 25,000 kPa (36000 psi)

### Reference

SMHS8319, Special Instruction

## 393-0369 Valve Guide Stop Collar

Model Usage: C4.4

Warranty: Six Months



- Used to install the valve guides to the correct height 12.7 mm (.50 in) above the spring seat on the cylinder head
- Protects valve guides during installation

Specifications	
Dimensions	25.5 x 30 mm (1.0 x 1.18 in)
Material	Steel



## FT1767 Valve Seat Insert Shrinker

Model: Most Cat® Engines

Warranty: None

- Used with carbon dioxide (CO2) to decrease (shrink) outside diameter of valve seat inserts for easy installation
- Takes about 10 seconds to shrink an insert
- Can also be used to shrink valve guides, bearings, and other small parts



### WARNING

Because of the pressures and temperatures involved, always wear safety glasses and insulated gloves when working with liquid and/or solid carbon dioxide (CO2).

## 6V-0087 Valve Stem Gauge

Model: Most Cat® Engines

Warranty: Six Months

- Used to measure valve stem wear more quickly than a micrometer
- Application includes all valves on current Cat® engines and most non-current engines (micrometer still needed to measure valves on D336, D334, 1674 and some other non-current engines)
- Has 4 accurately machined slots used for the four most common valve stem diameters
- Hardened to resist wear but will not damage valve stems
- If correct gauge slot slides over valve stem, valve is worn excessively and should not be reused



### Reference

SEBF8034, Guideline for Reusable Parts, Valves and Valve Spring Specifications (provides minimum use-again stem diameters for all valves used in Cat engines)

Item	Part Number	Description
1	5P-4227	Tag Holder, Form SEES5544 Instruction Card
2	6V-3198	Gauge
2	6V-3199	Gauge
--	6V-0087	Valve Stem Gauge

## 155-1536 Valve Recession Tool Kit

Model: 3500 and G3500 Engines

Warranty: Six Months

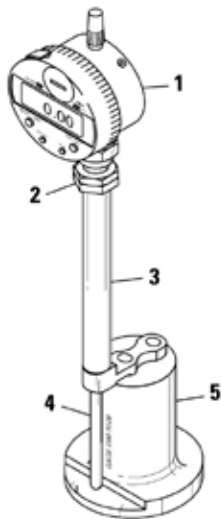

- Used to determine actual valve and valve seat wear
- Digital Indicator displays inches and millimeters

### Reference

NEHS0708, Tool Operating Manual

NEEG2811, Decal

Item	Part No.	Description
1	258-6575	Dial Indicator
2	5P-4814	Collet As - Clamp
3	155-1579	Base Assembly
4	155-1683	Rod Assembly
5	155-1643	Projection Gauge Block
<b>Not shown</b>		
--	6V-3073	Case - Plastic
--	258-6601	Foam Block

## 213-9285 Valve Recession Tool Kit

Model: G3400 Engine

Warranty: Six Months

- Used to determine the actual valve and valve seat wear
- Valve recession can be checked without removing rocker arms — reducing engine downtime
- Large center hole in support assembly provides clearance for spark plug tube on engines with Magneto and CDIS ignition systems
- Slots in support assembly allow access to valve rotator on either side of rocker arm
- Small magnets in legs of base assembly hold it in place while taking measurements

### Reference

NEHS0851, Tool Operating Manual, Operating Instructions for 213-9285 Valve Recession Tool Group for G3400 Engines

Included with 213-9285
Description
NEEG2946 Decal
NEHS0851 Tool Operating Manual



(Continued)

## 213-9285 Valve Recession Tool Kit (Continued)

Model: G3400 Engine  
Warranty: Six Months

Item	Part Number	Description
--	213-9285	Valve Recession Tool Kit
<b>Included with 213-9285</b>		
--	4C-3975	Case
--	213-9386	Foam Block
--	213-9198	Valve Recession Tool Group (Not Serviced)
<b>Included with 213-9198 (not serviced)</b>		
1	158-5080	Dial Indicator
2	5P-4814	Collet As - Clamp
3	213-9193	Base Assembly
4	230-5826	Support Assembly
5	213-9192	Rod Assembly
6	9S-8903	Point

## 334-7085 Valve Recession Kit

### Essential Tool

Model: All G3500C and G3500E Engines  
Warranty: Six Months

- Used to determine actual valve and seat wear on G3520C and G3520E Engines
- Can be used without removing rocker arms for reduced disassembly (less engine downtime)
- Indicator is set to zero using gauge block
- Horseshoe shaped plate bolts directly to cylinder head to provide a solid platform for 146-3270 Base Assembly (magnetic)
- For quick installation and removal, socket head cap screws are retained in horseshoe shaped plate with snap rings
- Can also be used with a 369-2607 Digital Indicator

### Reference

SEBU6711, Operation and Maintenance Manual, G3500 Engines, Valve Stem Projection - Measure/Record

Item	Description
3	Body Assembly
5	Rod Assembly
7	Plate Assembly
8	Gauge Block

Item	Part Number	Description
1 <sup>1,2</sup>	6V-3075	Indicator - Dial
2 <sup>1</sup>	5P-4814	Collet As - Clamp
3	146-3270	Base Assembly
4	9S-8883	Contact Point
--	334-7085	Valve Recession Tool Kit

<sup>1</sup>Part of 148-2997 Valve Recession Tool Kit

<sup>2</sup>Not included

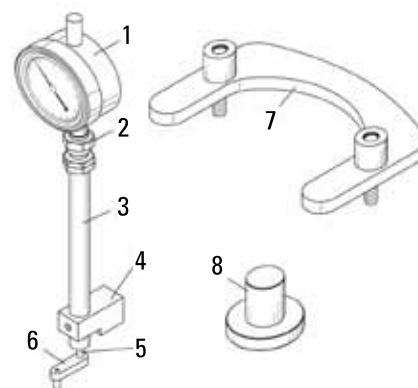

## FT1741 Vacuum Tester

Model: 3612, 3616

Warranty: None



- Used to check for leaks between valve face and seat on cylinder heads after valves and seats have been ground and valve springs assembled
- Consists of vacuum pump with connecting parts and set of 8 fabricated adapters to fit over all sizes of valves used in the Cat® Engine line

Item	Description	Quantity
2	Fabricated Adapters	8

Item	Part Number	Description
1	208-1356	Vacuum Pump

## 148-2997 Valve Recession Tool Kit

Model: 3600 and G3600 Engines

Warranty: Six Months

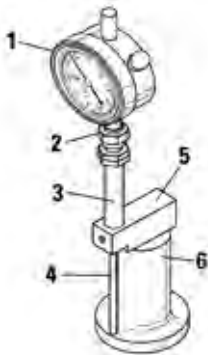

- Used to determine actual valve and valve seat wear
- Can be used without removing rocker arms (reduces engine downtime)
- Can be used with 369-2607 Digital Indicator

### Reference

NEHS0710, Tool Operating Manual

Item	Description
3	Body (not serviced separately)

Item	Part Number	Description
1	6V-3075	Indicator - Dial
2	5P-4814	Collet As - Clamp
4	146-3271	Extension Rod
5	146-3270	Base Assembly
6	146-2738	Projection Gauge Block
--	148-2997	Valve Recession Tool Kit

## Valve Recession Tooling

### Essential Tool

Model: C175 Engines

Warranty: Six Months

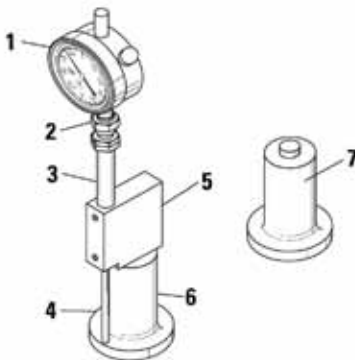

- Used to determine actual valve and valve seat wear
- Used with following parts from 148-2997 Valve Recession Kit:
  - Dial Indicator (1)
  - Clamp Collet (2)
  - Body (3)
  - Extension Rod (4)
- Can also be used with 369-2607 Digital Indicator (not part of group)
- Allows measurements without removing rocker arms (reduces engine downtime)
- 326-7689 Projection Gauge Block (6) used for intake valves
- 326-7693 Projection Gauge Block (7) used for exhaust valves
- Projection gauge blocks are laser etched with part number, intake or exhaust, and dimension for easy identification

(Continued)

## Valve Recession Tooling (Continued)

### Essential Tool

Model: C175 Engines  
 Warranty: Six Months

- 326-7698 Base Assembly (5) features 2 set screw locations  
 -Lower set screw is used with 3600 and G3600 Engines  
 -Upper set screw is used with C175 Engines
- 3 mm Allen wrench (dealer supplied) tightens appropriate set screw into locator hole in body (3)

### Reference

NEHS0710 Tool Operating Manual

Item	Description
3	Body (Part of 148-2997 Valve Recession Tool Kit)

Item	Part Number	Description
1 <sup>1 2</sup>	6V-3075	Indicator - Dial
2 <sup>1</sup>	5P-4814	Collet As - Clamp
4 <sup>1</sup>	146-3271	Extension Rod

Item	Part Number	Description
5	326-7698	Base Assembly
6	326-7689	Projection Gauge Block (Intake)
7	326-7693	Projection Gauge Block (Exhaust)

<sup>1</sup>Part of 148-2997 Valve Recession Tool Kit

<sup>2</sup>Not included

## Dowel Drivers

Model: See below  
 Warranty: Six Months

Part Number	Model
5P-2406	3400
6V-4009	3500

- Used to install valve train bridge dowels to correct height
- 5P-0944 Dowel Puller Group and 5P-0942 Extractor used for dowel removal



Typical Dowel Driver

## 5P-7333 Bridge Dowel Repair Tool Group

Model: 3400  
 Warranty: Six Months

- Used to repair cylinder heads with loose bridge dowels
- Repair done by drilling and reaming larger dowel hole and installing 5P-7324 Plug; plug then drilled and reamed for installation of new bridge dowel

### Reference

SMHS7072, Special Instruction

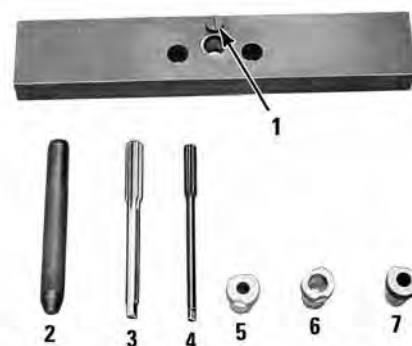

(Continued)

# Cylinder Head, Valves and Cam Followers

## 5P-7333 Bridge Dowel Repair Tool Group (Continued)

Model: 3400

Warranty: Six Months

Item	Part Number	Description
1	5P-7330	Screw
2	5P-7325	Driver
3	5P-7331	Reamer
4	5P-7332	Reamer

Item	Part Number	Description
5	5P-7326	Drill Bushing
6	5P-7328	Drill Bushing
7	5P-7327	Drill Bushing
--	5P-7333	Bridge Dowel Repair Tool Group

Engine Tools

## 3P-2243 Installer Group

Model: 6.25 inch Bore V-Engines

Warranty: Six Months



- Used to locate and install seals between valve lifter guide brackets on later 158.75 mm (6.25 in) bore V-engines (D379B, D398B, D399)

Item	Part Number	Description
1	1P-0529	Handle
--	0L-1404	Stud (attaches handle to installer)
--	3P-2243	Installer Group

## 5P-7433 Cam Follower Tool Group

Model: 3400

Warranty: Six Months

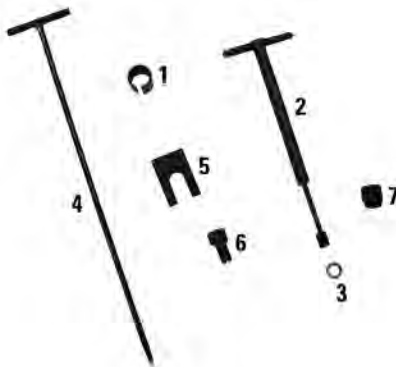

- Used for removal and installation of valve lifters

Item	Part Number	Description
1	417-1323	Compressor
2	5P-2408	Handle Assembly
3	5P-2685	Nut
4	5P-6599	Handle Assembly
5	5P-2395	Holder Assembly
6	5P-6601	Collet
7	5P-2400	Compressor
--	5P-7433	Cam Follower Tool Group

## Rocker Arm Bearing Installation Tools

Model: See below

Warranty: None

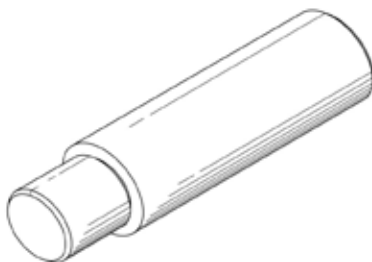

- Drivers used for proper installation of rocker arm bearings
- Material: SAE4140 steel

Part Number	Model
FT0190	D339, D342, D353, G353, D397, G397, D375, G375
FT0191	D326, D337
FT0192	D311H, D320, D330, D333, G333, 1670, 1673
FT0193	D398, G398, D379, G379

## Valve Lash Setting Tools

### Essential Tool

Model: 3500A and 3500B Diesel, 3500 Magneto and EIS Gas Engines

Warranty: Six Months

- Used to accurately set engine valve lash with factory setting methods
- Installation of tools is quick and easy with adjustment of indicator position required on initial set-up only
- Removal of fuel lines not necessary to measure valve lash
- Adding 147-2058 Extension to indicator allows valve lash to be measured on Magneto Gas engine without removing spark plug extension
- Socket and torque wrench used to torque rocker arm nuts are preset at factory to 70 N·m (52 ft·lb) — weight of torque wrench alone sets value of valve lash
- Valve bridge adjustment can be made without removing the rocker arm. Use the 147-5536 Contact Point, 147-2058 Extension, and 148-7211 Socket to make the adjustment.
- A slide rule type torque computer, Form SEHS7150, is available to determine torque wrench dial reading for different extensions
- This tool will not fit on some early 3500 Engines with old fuel manifolds.
- Dial indicator is not included in group — choice of 147-2056 (inch) or 147-5537 (mm) is available

### Reference

REHS0128, Special Instruction

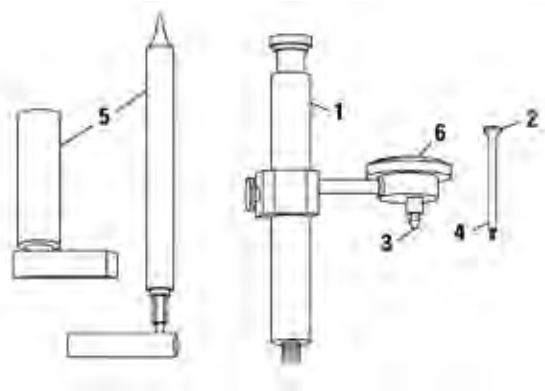

Item	Part Number	Description
<b>147-5482 Valve Lash Adjustment Group</b>		
1	145-5191	Support Assembly
2	147-5536	Contact Point
3	147-2057	Contact Point
4	147-2058	Extension
5	148-7211	Bridge Nut Socket
--	6V-3073	Case - Plastic
Not Shown	147-5535	Foam Block
<b>Required tooling not included in 147-5482 - must be ordered separately:</b>		
6	147-2056	Dial Indicator (inch), preferred, or
6	147-5537	Dial Indicator (metric)
<b>Recommended tooling not included in 147-5482 - must be ordered separately:</b>		
Not Shown	147-2060	Socket Wrench
Not Shown	147-2059	Torque Wrench

## 146-2597 Push Rod Holder

Model: 3114, 3116, and 3126 Engines with MUI Fuel Systems

Warranty: Six Months

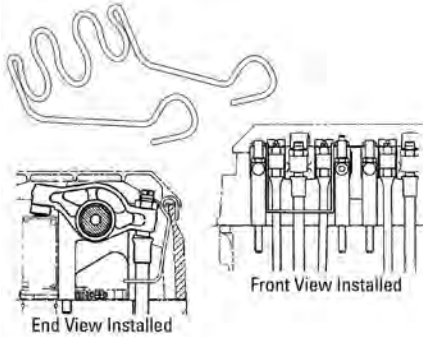

- Used to hold all three push rods in place while rocker arm assembly is installed to cylinder head
- Hook design ensures tool must be removed before valve cover can be installed
- Provides faster and easier method of installing rocker arm assemblies
- Individual holder tool design will work on either 4- or 6-cylinder engines

Part Number	Description
146-2597	Push Rod Holder

## 194-2062 Tool Group

Model: 3408 and 3412 HEUI Engines or G3500 Engines

Warranty: Six Months

### 3408 and 3412 HEUI Engines (194-2062 Tool Group)

- Used to make valve adjustment procedure much easier
- Used with standard screwdriver to set valve lash
- Wrench has extra deep socket to reach adjustment locknut
- Specially designed feeler gauge has both 0.381 mm (0.015 in) and 0.762 mm (0.030 in) settings required for valve lash procedure

### G3500 Engines (194-2061 Wrench)

- Used to adjust boost pressure of 146-0758 Exhaust Bypass Valve
- Used with a standard 6.35 mm ( 1/4 in) Nut Driver
- To access adjustment screw, remove 9S-4205 Plug
- Wrench can also be used to adjust valve bridges
- Socket end: 9/16 inch

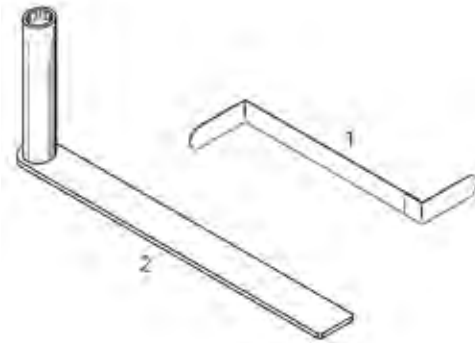

Item	Part Number	Description
1	194-2060	Gauge
2	194-2061	Wrench
--	194-2062	Tool Group



## Valve Lash Setting Tool

Model: 3500 Engines  
Warranty: Six Months

- Replaces discontinued 4C-8241 Valve Lash Setting Gauge
- Used to provide valve lash settings on 3500 A Series diesel engines
- Dial indicator eliminates guesswork by measuring exact valve gap (greatly reduces time needed to accurately adjust valves)
- Base assembly has an inner and outer sleeve: inner sleeve puts tension on rocker arm; outer sleeve puts pressure, in opposite direction, on valve bridge assembly; dial indicator measures gap to determine exact valve setting

### Reference

SEHS9261, Special Instruction

Indicator diameter	57 mm (2.25 in)
Graduations	0.025 mm (0.001 in)
Dial reading	0-50-0
Range	6.35 mm (0.250 in) total; 2.54 mm (0.100 in) per revolution

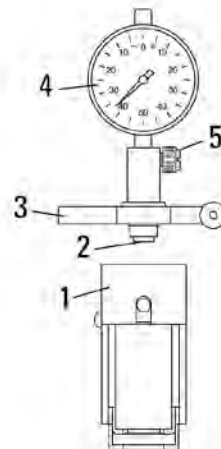

Item	Part Number	Description
<b>Assembled Valve Lash Setting Tool</b>		
1	125-2742	Base Assembly (for 3500)
2	6V-2057	Contact Point
3	125-2743	Collar Group
4	4C-8246	Indicator
5	9U-6272	Nylon Screw
Not shown	6V-2030	Extension <sup>1,2</sup>

<sup>1</sup> Used for FIETS and AVM with heavy duty coupling

<sup>2</sup> Part of 6V-6042 Indicator Contact Point Group

## Lifting Bracket Assemblies

Model: 3406E Engines and C11/13 Engines  
Warranty: Six Months

- Used to lift rocker arm assembly during removal and installation (keeps the assembly aligned)
- Fingers of lifting bracket fit through bolt holes in rocker arm shaft and firmly clamp assembly together
- Using the lifting bracket greatly decreases assembly time because valve and unit injector rocker arms are held in correct relation to one another (using lifting bracket allows the mechanic to have a free hand during assembly)

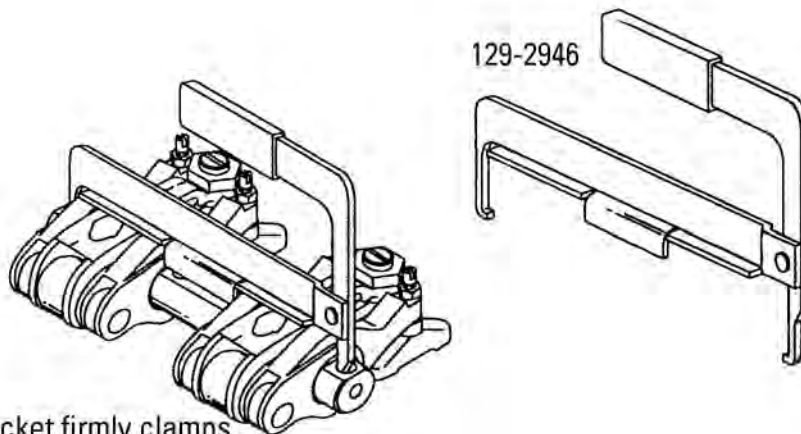

Lifting bracket firmly clamps rocker arm assembly together

(Continued)

# Cylinder Head, Valves and Cam Followers

## Lifting Bracket Assemblies (Continued)

Model: 3406E Engines and C11/13 Engines

Warranty: Six Months

Part Number	Description	Model
124-2946	Lifting Bracket Assembly	3406E Rocker Arm
293-2989	Lifting Bracket Assembly	C11/13 Rocker Arm

Engine Tools

## 8S-6691 Cylinder Head Stand Group

Model: 3100 and 3208

Warranty: Six Months



- Provide simple head support and clearance between head and work bench when service work required on cylinder heads
- 2 stands included in group

Part Number	Description
8S-6691	Cylinder Head Stand Group

## 9U-6238 Guide Bolt

Model: 3054 and 3056 Engines

Warranty: Six Months



- Used to align cylinder head with block during installation (2 bolts required)
- Screw driver slot used to easily install and remove the guide bolt
- Zinc coated to prevent corrosion

Part Number	Description
9U-6238	Guide Bolt

Overall length	127.0 mm (5.0 in)
Diameter	12.7 mm (0.5 in)
Thread	1/2 - 20 2A

## 185-5321 Cylinder Head Lifting Hook Assembly

Model: 3114, 3116, 3126, 3300, and 3400 (except 3126B and 3406E) Engines

Warranty: Six Months

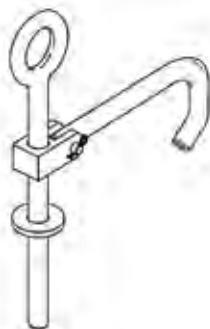

- Used to quickly and safely lift cylinder head core
- Designed for bare cylinder head "Core" handling only and not as an engine assembly tool
- Reduces potential injuries from manually handling cylinder head castings
- Easily attaches to core without bolts
- Straight leg inserts into middle bolt hole of cylinder head and hooked leg fits into breather opening on 3114, 3116, 3126 MUI/HEUI Engines or into exhaust port on 3300, 3406, 3408, and 3412 Engines

Maximum lifting capacity	340 kg (750 lb)
--------------------------	-----------------

Part Number	Description
185-5321	Cylinder Head Lifting Hook Assembly

## 199-1418 Hook Assembly

Model: 3406E, C-15, and C-16 Engines

Warranty: Six Months

- Used to quickly and easily lift cylinder head cores (camshaft must be removed prior to using tool)
- Used with an overhead lifting device
- Attaches easily without bolts or lifting eyes
- Grabs cylinder head core below camshaft bearing saddle
- Designed for bare head "core" lifting only



### NOTICE

To prevent camshaft and other cylinder head component damage, DO NOT use this hook assembly as an engine assembly tool.

Maximum lifting capacity	159 kg (350 lb)
--------------------------	-----------------

Part Number	Description
199-1418	Hook Assembly

## 5P-3021 Lifting Bracket

Model: 3406

Warranty: Six Months

Part Number	Description
5P-3021	Lifting Bracket

- Used for cylinder head removal and installation for 3406 Truck Engines with little or no access to rear lifting eye on cylinder head



## 5P-8700 Lifting Bracket

Model: 3408, 3412 Marine Engines

Warranty: Six Months

Part Number	Description
5P-8700	Lifting Bracket

- Used to remove and install cylinder head and exhaust manifold assemblies on 3408 and 3412 Marine Engines in narrow engine compartments
- Designed to be used in pairs for lifting cylinder head assemblies vertically at approximately same angle as they are positioned on block; brackets attached to heads between end cylinders; two OS-1618 Bolts, 5/16 inch-18 thread, 25.4 mm (1.0 in) long required for each bracket



## 165-4638 Guide Manifold

Model: 3400 Engines

Warranty: Six Months



- Used to install exhaust manifolds
- Threads onto manifold stud for positive retention

Part Number	Description
165-4638	Guide Manifold

## 1U-8264 Head Lifting Bracket

Model: 3176, C10, and C12 Engines

Warranty: Six Months

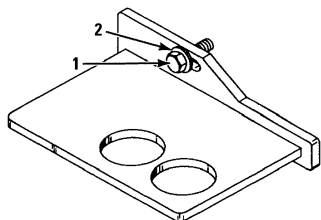

European Union compliant, CE marked

- Used to remove and install cylinder head
- Used with two 6V-3668 Bolts and 5P-8245 Hard Washers
- Use one of two lifting holes, depending on which head is being removed
- Slotted mounting holes allows mechanic to easily balance cylinder head before lifting

Working load limit	114 kg (250 lb)
--------------------	-----------------

Item	Part Number	Description
1	6V-3668	Bolt
2	5P-8245	Hard Washer
--	1U-8264	Head Lifting Bracket

## 209-1368 Head Lifting Bracket

Model: C-9 Engine

Warranty: Six Months

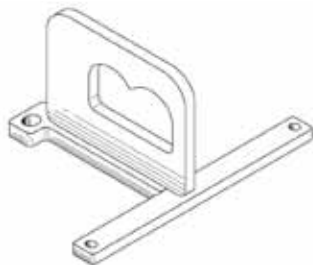

European Union compliant, CE marked

- Used to lift cylinder head with or without exhaust manifold and turbocharger
- Two lifting positions allow head to remain level during lifting procedure
- Bolts to cylinder head using two 6V-2317 Bolts, one 6V-3668 Bolt, two 5M-2894 Washers, and one 5P-8245 Washer (not part of lifting bracket)

Working load limit	159 kg (350 lb)
--------------------	-----------------

Part Number	Description
209-1368	Head Lifting Bracket

## 367-3535 Timing Case Cover Alignment Tool

Model Usage: C7.1

Warranty: Six Months

- Used to correctly align pressed steel timing case cover to the timing case

Specifications	
Dimensions	5.8 x 3.75 x 3.75 in (147 x 95.25 x 95.25 mm)
Material	Steel

Part Number	Description
367-3535	Timing Case Cover Alignment Tool

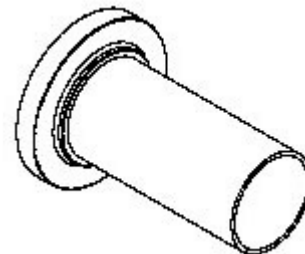

## 371-1079 Head Lifting Bracket

Model Usage: C175

Warranty: Six Months

- Allows operator to quickly and easily lift engine cylinder head
- Multiple lifting points enables cylinder head to be at lifted level or at the angle of the block deck
- Threaded block allows convenient use of handle (126-6920)
- Requires five M8 - 1.25 x 25 mm (6V-3940) and two M14 - 2.0 x 35 mm (6V-8550) bolts (purchased separately) for fastening bracket to cylinder head
- CE Compliant



### Reference

NEHS1128, Tool Operating Manual

Specifications	
Part Number	Description
Weight	3.7 kg (8.61 lbs)
Working Load Limit	136 kg (300 lbs)

Part No.	Description	Dimensions
371-1079	Head Lifting Bracket	286 x 253 x 128.1 mm (113 x 10 x 5 in)

## 185-3145 Lifting Bracket Assembly

Model: 3406E, 3456, C-15, and C-16 Engines

Warranty: Six Months

Part Number	Description
185-3145	Lifting Bracket Assembly

- Used to quickly and easily lift cylinder heads
- Attaches with six 1B-7182 Bolts and 9M-1974 Hard Washers or equivalent (not included)
- Designed for a bare cylinder head, with or without camshaft
- Includes multiple hook points for proper balancing

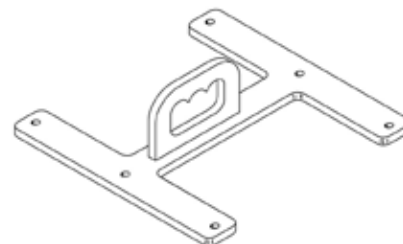

## 370-8083 Cylinder Head Lifting Bracket

Model: 3406E, 3456, C-15, C-16 Engines

Warranty: Six Months

European Union compliant, CE marked

- Used to quickly and easily lift cylinder heads with exhaust manifold and turbo charger attached.
- Includes multiple lift points to help keep cylinder head level during installation.
- Uses three 5/16" - 18 x 1 1/4" (1B-7182) and two 1/2" - 13 x 3 1/4" (0V-0375) bolts to fasten bracket to cylinder head. (Bolts are purchased separately.)

### Reference

NEHS1114, Tool Operating Manual

Specifications	
Dimensions	363 x 252 x 160 mm (14.3 x 9.9 x 6.3 in)
Weight	4.5 kg (10 lbs)
Working Load Limit	430.91 kg (950 lbs)

Part Number	Description
370-8083	Cylinder Head Lifting Bracket

## Sleeve Replacement Tools

Model: 3114, 3116 and 3126 Engines

Warranty: Six Months

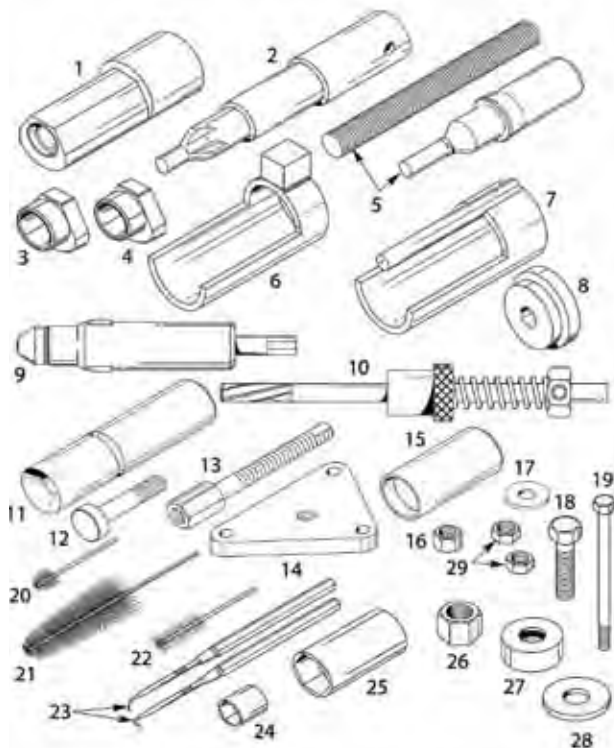

- 143-2099 Sleeve Replacement Tool Group replaces the former 127-3458 Sleeve Replacement Tool Group
- The former 127-3458 Sleeve Replacement Tool Group can be UPDATED to the new configuration simply by purchasing the 143-2098 Sleeve Removal Tool Group; previous tooling not listed below is no longer needed for the new procedures
- These new improved tools are simpler and make the job faster and easier — offering the following benefits over the former 127-3458 Tool Group:
  - No tapping of old sleeves — means less debris, no stripped threads and no problem with loose sleeves turning
  - Works in low-overhead applications, such as cylinders #5 and #6 in GM truck chassis, Cat® machine installations, and others
  - Should be no need to remove the cylinder head from the engine for sleeve replacement
- Used on engines equipped with Mechanical Unit Injectors (MUI) or Hydraulic Actuated Electronically Controlled Unit Injectors (HEUI)
- Engines produced since early 1994 have had injector sleeves roller expanded at the factory; the original 4C-4462 Tool Group will not pull these sleeves (either the 127-3458 or the 143-2099 Tool Group is required)
- All special tooling necessary to efficiently remove, install, and ream copper injector sleeves is included in a single custom case in the 143-2099 Group (some additional shop supplies are also required, as specified in the Tool Operating Manual NEHS0675)

(Continued)

## Sleeve Replacement Tools (Continued)

Model: 3114, 3116 and 3126 Engines

Warranty: Six Months

Item	Description
18	Bolt
Included (Not shown)	
NEEG2748	Decal
NEHS0675	Tool Operating Manual, "Using the 143-2099 Sleeve Replacement Tool Group on 3114, 3116 and 3126 Engines"

143-2099 Sleeve Replacement Tool Group			
Item	Part Number	Description	Size
1	125-7060	Driver	--
3	4C-8714	Guide Bushing (large)	--
4	4C-8715	Guide Bushing (small)	--
6	125-7059	Reaction Sleeve (HEUI)	--
7	9U-5671	Receiver Sleeve Adapter <sup>1</sup>	--
8	4C-5572	Plate (for reaction sleeve)	--
9	121-2920	Roller Expander	--
10 <sup>2</sup>	9U-6101	Reamer Group	--
11	142-8278	Swage Tool	--
12	142-8279	Sleeve Puller	--
13	142-8280	Sleeve Stud	--
14	142-8281	Plate	--
15	143-8612	Driver	--
17	7D-1649	Hard Washer	--
19	6V-3821	Hex Bolt	M8 x 1.25, 110 mm (4.3 in) long
20	4C-5553	Sleeve Cleaning Brush (tapered)	--

143-2099 Sleeve Replacement Tool Group			
Item	Part Number	Description	Size
21	126-3297	Large Bore Brush	--
22	4C-5570	Small Bore Brush	--
23	9U-6859	Pick Set	--
24	214-6625	Socket	11 mm, 3/8 in square drive, six point
25	213-3530	Socket	1 1/8 in
26	2J-3506	Nut	3/4 - 10 thd
27	1U-8826	Thrust Bearing	--
28	2S-0115	Washer	--
29	1B-4430	Jam Nut	1/2 - 20
Item 2 - Reamer Assembly <sup>3</sup>			
2	4C-8713	Reamer Shank	--
2	4C-5502	Set Screw	--
Item 5 - Swage Assembly			
5	4C-5573	Swage (sleeve)	--
5	4C-5548	Stud	3/4 - 10 thd x 5 1/2 in
Not shown			
1	6V-7145	Case	--
--	125-0684	Foam Insert	--

<sup>1</sup>9U-5671 Sleeve 36.0 mm (1.42 in) 98.0 mm (3.86 in) Open end

<sup>2</sup>Includes: 9U-6102 Reamer, 9U-6103 Collar, 9U-6104 Compression Spring, and 9U-6105 Guide Bushing

<sup>3</sup>Includes: Reamer Head

# Cylinder Head, Valves and Cam Followers

## 143-2098 Sleeve Removal Tool Group

Warranty: Six Months

Engine Tools

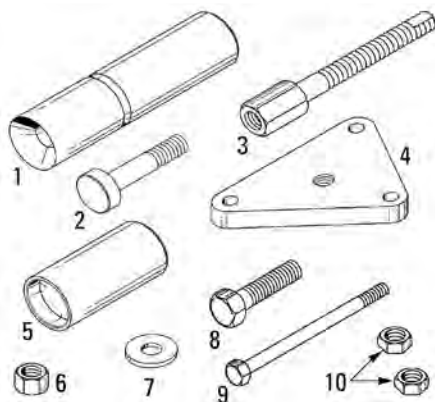

Included (Not shown)	
Item	Description
NEEG2748	Decal
NEHS0675	Tool Operating Manual, "Using the 143-2099 Sleeve Replacement Tool Group on 3114, 3116 and 3126 Engines"

143-2098 Sleeve Removal Tool Group			
Item	Part Number	Description	Size
1	142-8278	Swage Tool	--
2	142-8279	Sleeve Puller	--
3	142-8280	Sleeve Stud	--
4	142-8281	Plate	--
5	143-8612	Driver	--
6 <sup>1</sup>	3L-2415	Full Nut and Hex Bolt (forcing bolt)	Nut 1/2 - 13, Bolt 1/2 - 20, 63.5 mm (2.5 in) long
7	7D-1649	Hard Washer	--
9	6V-3821	Hex Bolt	M8 x 1.25, 110 mm (4.3 in) long
10	1B-4430	Jam Nut	1/2 - 20
--	143-2098	Sleeve Removal Tool Group	--

<sup>1</sup>Item 8 is Bolt

## 139-0692 Sleeve Jaw

Model: 3114, 3116, 3126 Engines

Warranty: Six Months

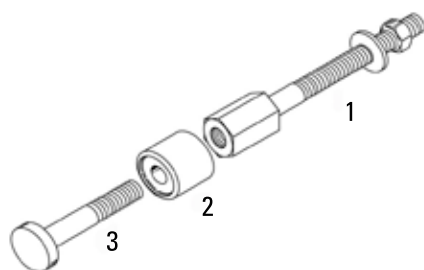

- Used with 143-2099 Sleeve Replacement Tool Group to aid in sleeve pulling operation
- Sharp chamfer rolls top of injector sleeve over sleeve stud, reducing chance of stud pulling out

Item	Description
1	Pulling Stud
3	Sleeve Stud

Item	Part Number	Description
2	139-0692	Sleeve Jaw



## 131-8362 Reamer Head

### Essential Tool

Model: 3114, 3116, and 3126 Engines

Warranty: Six Months

Part Number	Description
131-8362	Reamer Head

- For reaming tapered injector seat in copper alloy injector sleeves
- Used with 143-2099 Sleeve Replacement Tool Group
- Made from solid carbide for superior life and performance

#### Reference

NEHS0675, Tool Operating Manual

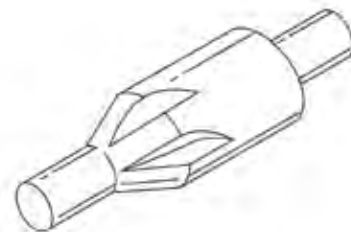

## 385-8470 Valve Guide Reamer

Model Usage: 308E, 906H, 907H, 908H, and any C3.3B engine

Warranty: Six Months

- Used to properly install valve guides
- Used to ream value guide for the C3.3B engine

385-8470 Specifications	
Dimensions	178 x 7.1 mm (7.01 x .280 in)



## 417-4368 Reamer

Model Usage: Various Caterpillar Engines

Warranty: Manufacturer's

- Used if the sleeve of the unit injector has been removed from the engine to remove carbon on 3126B, C7, C9 and C9.3 engines
- Can also be used to ream valve guides to correct dimension within tolerance
- 9/32 inch (7.14mm)

Specifications		
Part Number	Description	Dimensions
417-4368	Reamer	178 x 7.1 mm (7.01 x .280 in)



## 121-2920 Roller Expander

Model: 1.1/1.2 L Engines

Warranty: Six Months

Part Number	Description
121-2920	Roller Expander
Service/Repair Parts	
4C-6732	Race
4C-6733	Bearing
4C-6737	Retaining Ring
4C-6738	Retaining Ring

- Included with 143-2099 Sleeve Replacement Tool Group
- Helps ensure positive seal of sleeve to injector bore
- Easy to use — use torque wrench to turn in sleeve, up to 11 N·m (8 ft·lb)
- To update 4C-4462 Injector Sleeve Removal and Installation Tool Group

#### Reference

NEHS0675, Tool Operating Manual, "Using the 143-2099 Sleeve Replacement Tool Group on 3114, 3116 and 3126 Engines"



## 151-4832 Sleeve Remover Assembly

Model: 3126B HEUI Engines

Warranty: Six Months

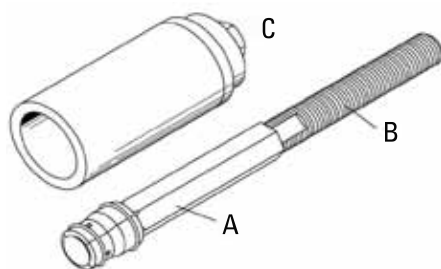

- Used to easily remove injector sleeves
- Designed for non-grooved injector sleeves
- Includes 177-7804 Segment Collet

### Application Procedure

1. Insert tool fully into injector sleeve bore. Expand tool by turning part A and part B in opposite directions. Sharp set screw points should bite into walls of sleeve.
2. Install pulling bridge, thrust bearing, washer, and nut (item C, part of tool group). Tighten nut on puller stud to remove sleeve.

### Reference

REN1369, Special Instruction, Unit Injector Sleeves

### NOTE:

Set screw points should protrude approximately 2.0 mm (0.08 in) from surface of pulling tool collet.

Thread	3/4 - 10
Overall assembled length with puller	254 mm (10 in)
Points	141-4635 Set Screw
Item	Description
A	Expanding segment
B	Threaded rod
C	Puller components

Part Number	Description
151-4832	Sleeve Remover Assembly

## 173-1530 Injector Seating Tool Group

### Essential Tool

Model: 3114, 3116, 3126 MUI and 3116, 3126 2-Valve HEUI Engines

Warranty: Six Months

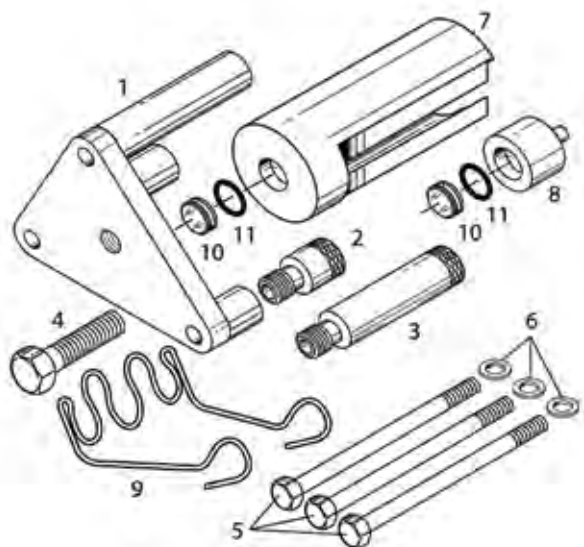

- Used to seat entire injector seating land into sleeve (eliminates combustion gas leakage)
- Used with 9U-5019 Torque Wrench
- Trues up out of round injector sleeves that cause combustion gas leakage
- Eliminates need to ream newly installed sleeves
- Eliminates injector clamp bolt load relaxation
- Provides consistent seating force from cylinder to cylinder using a simple forcing screw operation
- Works with existing sleeve removal and installation tooling
- Can be used in place of 142-8279 Plate used for sleeve removal for more control of location
- Forcing bridge mounts same as 142-8279 Plate
- Interchangeable legs work on bare head or with intake manifold in place

### Reference

NEHS0738, Using the 173-1530 Injector Seating Tool Group on 3114, 3116, 3126 MUI and 3116 and 3126 2-Valve HEUI Engines

(Continued)

## 173-1530 Injector Seating Tool Group (Continued)

### Essential Tool

Model: 3114, 3116, 3126 MUI and 3116, 3126 2-Valve HEUI Engines

Warranty: Six Months

Included (Not shown)	
Item	Description
NEEG2838	Decal, Case

Item	Part Number	Description
1	173-1529	Forcing Bridge
2	173-1534	Short Spacer Leg
3	173-1535	Long Spacer Leg
4	3L-2415	Full Nut and Hex Bolt (forcing bolt)
5	7X-0457	Hex Head Bolt (for forcing bridge)
6	9M-1974	Washer
7	173-1531	Injector Forcing Cover (MUI)

Item	Part Number	Description
8	173-1532	Injector Forcing Cover (HEUI)
9	146-2597	Push Rod Holder
10	175-7801	Wear Button
11	1P-8116	O-ring
--	173-1530	Injector Seating Tool Group
Not shown		
3	6V-3073	Case - Plastic
--	173-1528	Foam Insert

## 170-9227 Reamer Shims

Model: 3116 and 3126 MUI, 3126 HEUI Engines

Warranty: Six Months

- Used to control depth of injector sleeve reaming operation; helps eliminate reamer chatter
- Allows only 0.25 mm (0.01 in) of material to be removed at a time — can prevent sleeve from being reamed too deep
- Provides a positive stop at end of reaming operation
- Thickness: 0.25 mm (0.01 in)
- Number of shims per packet: 4

### Application Procedure

1. Start with 4 shims installed between 4C-8713 Reamer Shank (2) and 4C-8714 Bushing (3).
2. Ream sleeve until reamer shank contacts shim.
3. Remove one 0.25 mm (0.01 in) shim at a time and repeat until proper seat depth is obtained.

### Reference

NEHS0675, Tool Operating Manual

Item	Part Number	Description
1	170-9227	Reamer Shims
2	4C-8713	Reamer Shank
3	4C-8714	Guide Bushing (large)

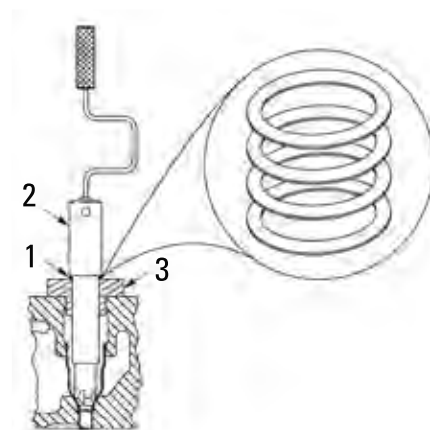

## 131-3921 Puller Group (HEUI)

Model: 3408 and 3412 HEUI Engines

Warranty: Six Months

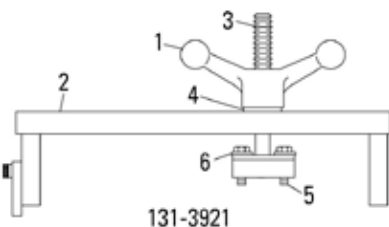

- Used to easily remove carbon-fouled injectors from cylinder head
- Puller has large, balled end, handle for easier removal
- Puller bridge assembly sits on cylinder head top surface and uses a pivoting leg extension to keep bridge from sliding off of cylinder head

131-3921 Injector Puller Group	
Stud assembly overall length	118.5 mm (4.67 in)
Stud thread	3/8 - 16
Bolt size	1/4 - 20
Distance between bolt holes	29 mm (1.1 in)
Bridge overall length	270 mm (10.7 in)

Item	Part Number	Description
1	131-8196	Handle
2	131-8197	Puller Bridge Assembly
3	131-8198	Puller Stud Assembly
4	093-0386	Puller Stud Assembly
5	0S-1616	Bolt
6	4B-4276	Flat Washer
--	131-3921	Puller Group (HEUI)

## 111-5051 Injector Wrench (3408 and 3412 HEUI)

Model: 3408 and 3412 HEUI Engines

Warranty: Six Months

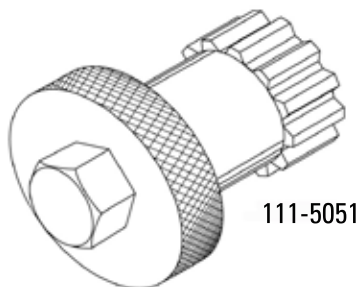

- Used to remove and install stainless steel injector sleeves
- Used with 3/4 inch socket
- Spline on tool engages internal spline in sleeve

Part Number	Description	Hex Size	Knurled Washer Diameter	Spline
111-5051	Injector Wrench	3/4 in	50.8 mm (2 in)	48 - tooth

## 164-5924 Injector Bore Gauge, 164-5927 Tube Brush

### Essential Tool

Model: 3408 and 3412 HEUI Engines

Warranty: Six Months

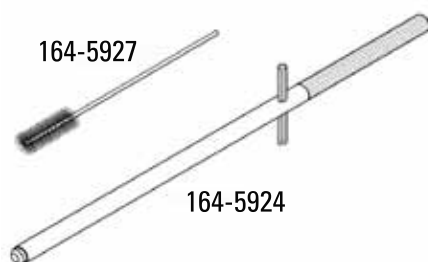

- Used to clean and check clearance of injector sleeve tip area
- Proper cleaning of injector tip bore is mandatory when changing HEUI engine injectors
- Tools are included in 163-1575 HEUI Injector Rework Kit

Part Number	Description
164-5924	Injector Bore Gauge
164-5927	Tube Brush

### Reference

REHS0116, Special Instruction

## 4C-8714 Guide Bushing (Large), 4C-8715 Guide Bushing (Small)

### 9U-5671 Reaction Sleeve

Model: 3114 and 3116 Engines

Warranty: Six Months

Part Number	Description
4C-8714	Guide Bushing (large)
4C-8715	Guide Bushing (small)
9U-5671	Receiver Sleeve Adapter <sup>1</sup>

- Used to replace and ream injector sleeves without removing valve springs — saves time
- 9U-5671 is designed to clear the valve springs and provide adequate support for pulling the injector sleeve
- 4C-8714 and 4C-8715 Guide Bushings allow reaming and sleeve installation without valve spring removal



#### Reference

SEHS9120, Special Instruction

<sup>1</sup>9U-5671 Sleeve 36.0 mm (1.42 in) 98.0 mm (3.86 in) Open end

## 4C-6591 Bottom Swage

Model: 3176

Warranty: Six Months

Part Number	Description
4C-6591	Bottom Swage

- Replaces discontinued 4C-6714 Bottom Swage
- Used to install injector sleeves in 3176 Engine cylinder heads
- Addition of pilot extension and lead-in chamfer ensure proper swaging of bottom of injector sleeve

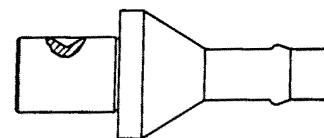

#### Reference

SEHS9246, Special Instruction

## 9U-6891 Injector Tool Group

Model: C-10, C-12, and 3406E Engines

Warranty: Six Months

- 128-7889 Puller Bridge replaces discontinued 9U-7260 Puller Bridge (new puller bridge can be used on all three engines)
- Injector tool group is used to remove and install injector sleeves

#### References

SENR6421, 3406E Service Manual, Disassembly and Assembly

SENR1002, C-10 Disassembly and Assembly

SENR1007, C-12 Disassembly and Assembly

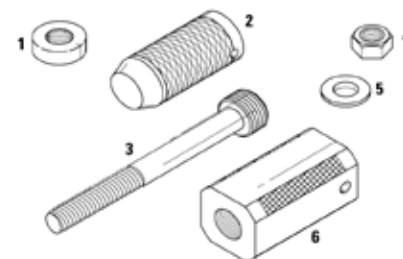

Item	Part Number	Description
1	9U-6877	Thrust Bearing
2	9U-7258	Driver Cap
3	221-9778	Puller Stud
4	4K-0367	Nut - Full
5	5P-8247	Hard Washer
6	128-7889	Puller Bridge
--	9U-6891	Injector Tool Group

## 312-3204 Injector Brush

### Essential Tool

Model: C175 Engine

Warranty: Six Months



- Used to clean injector bores before inserting injectors
- Tapered design for easy insertion and efficient cleaning action
- Overall length: 350 mm (13.8 in)
- Diameter: 32 mm (1.26 in)
- Wire filament diameter: 0.25 mm (0.010 in)

Part Number	Description
312-3204	Injector Brush

## 9U-6860 Tool Group

Model: 3176, 3176B

Warranty: Six Months



- Replaces discontinued 4C-4054 Tool Group
- Used to install, clean, and ream injector sleeves in cylinder head

### References

SEHS8884, Unit Injector Test Specifications

SENR5109, 3176 Service Manual

SEHS9246 Special Instruction, operation

Part Number	Description
9U-6860	Tool Group
1B-2886	Bolt
8H-8556	Socket, 1 in
213-3530	Socket
1U-8826	Thrust Bearing
2J-3506	Nut
2S-0115	Washer
3S-2713	Full Hardened Nut
4C-5502	Set Screw
4C-5538	Reamer Head
4C-5552	Large Bore Brush
4C-6591	Bottom Swage
4C-6730	Roller Expander <sup>1</sup>
4C-8720	Guide Bushing

Part Number	Description
4C-8721	Guide Bushing
4C-9495	Tee Handle
7X-0613	Hard Washer
9U-6631	Foam Insert Set
9U-6851	Lower Pilot
9U-6853	Tap
9U-6854	Puller Screw
9U-6855	Reamer Shank
9U-6856	Flare Tool
9U-6857	Driver
9U-6858	Bridge Plate
9U-6859	Pick Set
9U-6861	Puller Stud
9U-6862	Small Tapered Brush
9U-6863	Small Bore Brush

<sup>1</sup> Includes 4C-6732 Race, 4C-6733 Bearing, 4C-6734 Roll, 4C-6735 Cage, and 4C-6738 Retaining Ring

## 169-3374 Injector Sleeves Tool Group

Model: 3176 and 3176B Engines

Warranty: Six Months

- Used to quickly and easily remove brass injector sleeves
- Eliminates sleeve tapping (threading) operation — no brass chips to fall into engine
- Similar to current 3100 Engine brass sleeve removal procedure

### Reference

NEHS0734, Tool Operating Manual, 169-3374 Brass Injector Sleeve Removal Group for 3176 and 3176B Engines

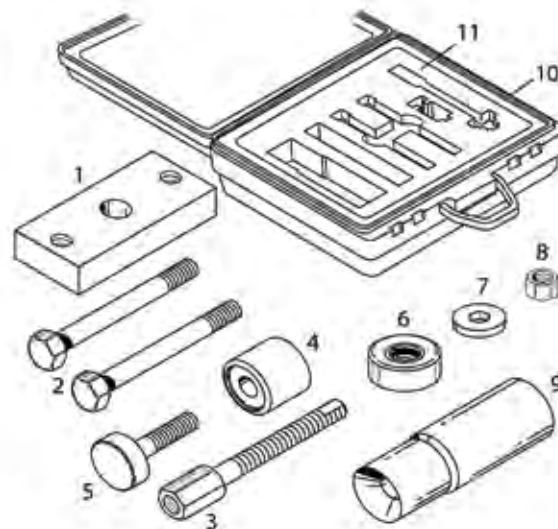

Item	Part Number	Description
1	9U-6858	Bridge Plate
2	1B-2886	Bolt
3	142-8280	Sleeve Stud
4	151-4833	Sleeve Jaw
5	156-2870	Puller Stud
6	1U-8826	Thrust Bearing

Item	Part Number	Description
7	7D-1649	Hard Washer
8	1F-7958	Full Nut (1/2 - 13) (fork mounting hardware)
9	156-2869	Crimping Swage
10	6V-3073	Case - Plastic
11	173-5508	Foam Insert
--	169-3374	Injector Sleeves Tool Group

## C9.3 Engine Head Assembly Tools

Model Usage: C9.3

Warranty: Six Months

- Multifunction tool used to correctly remove and install C9.3 injector sleeves
- Removal requires 3/8 - 16 slide hammer shaft (i.e. 6V-2166)
- Long shank tap supplied for machining grooves in sleeve for easy removal
- Supplied o-ring prevents debris from entering combustion chamber during removal
- 364-0745 and 371-1603 required to remove and install valve spring retainers



364-2687



364-0745



371-1603

Specifications			
Part Number	Description	Dimensions	Weight
364-0745	Hold Down Plate	35 x 67.9 x 4 mm (1.4 x 2.7 x .16 in)	.026 kg (.57 lb)
364-2687	Sleeve Puller	32 x 109 mm (1.3 x 4.3 in)	.45 kg (.99 lb)
371-1603	Valve Spring Compressor	28 x 75 x 32 mm (1.1 x 3.0 x 1.3 in)	.204 kg (.45 lb)
Not Shown			
370-8733	Tap - Shank (M6 x 1)	120 - 140 mm long (4.7 - 5.5 in)	.54 kg (1.2 lb)

## 372-7975 C7 Injector Sleeve Removal/Installation Tool

Model: C7 Engines

Warranty: Six Months

- Used to remove and install the injector sleeve on C7 Engines
- Uses a 1/4" - 28 x 6" long tap, purchased separately (example McMaster - Carr 2589A26)
- Uses 2, 1/4" - 28 bolts to engage threads in sleeve after threads have been cut to remove sleeve
- Install top portion of tool to use as an installer to tap new sleeve in place
- Black oxide coating and hardened steel allow for durability and resistance to rust

### Note:

Tool shown in install configuration (remove end piece to use as removal tool)

Specifications	
Dimensions	35 x 185 mm (1.38 x 7.28 in)
Weight	1.2 kg (2.65 lbs)

Part Number	Description
372-7975	C7 Injector Sleeve Removal/Installation Tool

## 333-0759 Injector Sleeve Tool

### Essential Tool

Model: C175 Engines

Warranty: Six Months



- Used to remove and install externally threaded injector sleeves on C175 Engines
- Used with 1/2 inch drive wrench to install (screw in) and remove (screw out) threaded style injector sleeve
- Four hardened teeth (RKW C45-55) engage notches on interior of injector sleeve
- Longer length easily reaches down into cylinder head
- Durable, welded-steel construction with black oxide coating for corrosion resistance

### References

KENR6052, C175-16 and C175-20 Engines For Caterpillar Built Machines, Disassembly and Assembly

REN7466, C175-16 Generator Set Engine, Disassembly and Assembly

Part Number	Description
333-0759	Injector Sleeve Tool

## Screw-In Precombustion Chamber Tools

Model: Most Cat® Engines

Warranty: Six Months

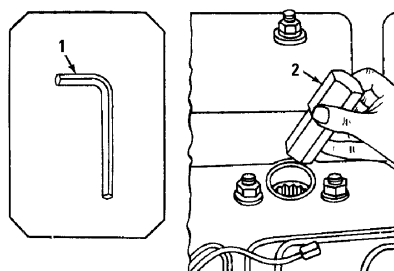

- 1D-5343 Wrench required to remove set screw and 1F-0479 Tool to loosen precombustion chamber on earlier screw-in type precombustion chambers
- 1F-0479 Tool also used to install these earlier precombustion chambers

Item	Part Number	Description
1	1D-5343	Wrench
2	1F-0479	Tool



## Drive-In Precombustion Chamber Tools

Model: Most Cat® Engines

Warranty: Six Months

Part Number	Description
6V-3160	Cylinder Group

- Hydraulic puller combined with tools shown provides simple and efficient method of removing drive-in type precombustion chamber
- Same tools can be used without hydraulic puller
- Driver used to install drive-in type precombustion chambers in cylinder heads; lower end of this tool serves as pilot so hammer blows can be directed squarely on upper end of chamber

Includes:	Saddle
-----------	--------



Engine Tools

## 5F-9217 Precombustion Chamber Tool Group

Model: Most Cat® Engines

Warranty: Six Months

- Engines with 1-piece precombustion chambers require only 5F-8353 Wrench for removal and installation

Item	Part Number	Description	Use
1	1A-2208	Bolt	Remove precombustion chamber retainer
2	5F-9072	Spacer	Remove precombustion chamber retainer
3	5F-8353	Wrench	Remove and install precombustion chamber
4	4B-4285	Washer	Replace precombustion chamber retainer
5	0L-1017	Nut	Replace precombustion chamber retainer
6	6F-5515	Screw	Replace precombustion chamber retainer
--	5F-9217	Precombustion Chamber Tool Group	--

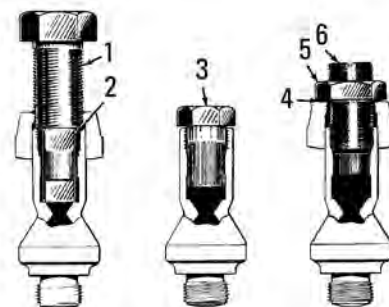

## 8S-0225 Precombustion Chamber Wrench

Model: 1674, D334, 3400

Warranty: Six Months

Part Number	Description
8S-0225	Precombustion Chamber Wrench

- Used to remove and install precombustion chambers on 1674, D334, and 3400 Series Engines

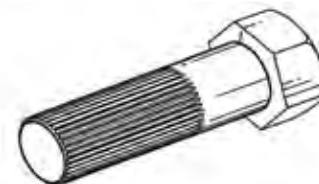

## 5P-0125 Precombustion Chamber Wrench

Model: 3204, D3, 910, 931

Warranty: Six Months



Model: 3204, D3, 910, 931

- Used to remove and install precombustion chambers on 3204 Engine in D3 Tractors, 910 Wheel Loaders, and 931 Track Loaders

Part Number	Description
5P-0125	Precombustion Chamber Wrench

## 5P-0961 Fuel Valve Adapter Wrench

Model: 3400

Warranty: Six Months



- Used for removal and installation of direct injection fuel valve adapters on 3400 Series Engines

Part Number	Description
5P-0961	Fuel Valve Adapter Wrench

## 5S-0276 Glow Plug Wrench

Model: Multiple Engine Models

Warranty: Six Months



- Used to remove and install glow plugs with 9.525 mm (3/8 in) hex on D4E, D6D, D6H, 637D, 977L

Part Number	Description
5S-0276	Glow Plug Wrench

## Glow Plug Tools

Model: Most Cat® Engines

Warranty: Six Months



- Wrenches and guide screws needed for installation and removal of glow plugs with 7.93 mm (5/16 in) hex on earlier engines

Item	Part Number	Description
1.0	1H-5656	Wrench
2.0	8S-2243	Wrench
3.0	9S-2573	Socket
5.0	9F-4571	Guide Screw
6.0	5H-7446	Guide Screw

## 390-1134 Plug Adapter

Model Usage: C3.3B engines

Warranty: Manufacturer's

- Used to check engine compression from a glow plug port
- Used to verify that compression is at correct level

Specifications	
Dimensions	193.6 x 19.1 mm (7.6 x .75 in)

Part Number	Description
390-1134	Plug Adapter



## 161-3440 Socket

### Essential Tool

Model: C-10 and C-12 Engines

Warranty: Six Months

- Used to tighten cylinder head bolts under water manifold without removing it
- Works on both single and dual thermostat housings
- Required according to PS4435 Product Support Program
- Do NOT use with impact driver
- Heat-treated for added durability and long life

Square drive	3/4 in
Double hex socket	M16 bolts
Overall length	190 mm (7.5 in)

Part Number	Description
161-3440	Socket



## FT1322 Lever Assembly

Model: 3400

Warranty: None

- Permits removal and installation of glow plugs and precombustion chambers without removing valve cover base and rocker arm shaft



## FT0869 Cylinder Head (or Hydraulic Cylinder) Storage Rack

Model: All Cat® Engines

Warranty: None



- Provides excellent facility for storing cylinder heads
- With modifications, can also be used for hydraulic cylinder storage

## 9U-7511 Spark Plug Seat Cleaner

Model: 3500 and 3600 Spark Ignited Engines

Warranty: Six Months

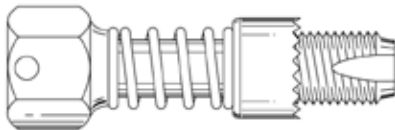

- Used to clean gasket seat of rust resulting from a leaking gasket
- Used to clean threads in cylinder head

### Reference

NEEG2585, Decal (instructions for inside lid of case)

External hex	22.225 mm ( 7/8 in)
Internal square drive	3/8 in
Thread	M18 x 1.5 mm
Overall length	75 mm (3.0 in)

Part Number	Description
9U-7511	Spark Plug Seat Cleaner
<b>To build service kit, order:<sup>1</sup></b>	
9Y-6792	Gasket (standard), 25 each
105-7124	Gasket (oversize), 25 each
9U-7512	Foam
6V-6045	Case - Plastic, NEEG2061 Accessories Case Decal

<sup>1</sup> Also order: NEEG2585 Decal (inside lid) and NEEG2586 Decal (outside case)

## 154-9521 Spark Plug Seat Cleaner

Model: G3400 Engines

Warranty: Six Months

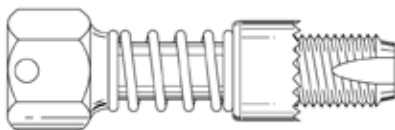

- Used to simultaneously clean rust and debris from gasket seat and cylinder head threads
- Used with 3/4 inch, 6 point socket (do not use 12 point socket)
- Spring-loaded design only removes dirt and debris, not metal

Part Number	Description
154-9521	Spark Plug Seat Cleaner

Thread size	M14 x 1.25
External hex	19 mm (0.75 in)
Overall length	75 mm (3.0 in)

## FT0868 Cylinder Head Component Parts Rack

Model: All Cat® Engines

Warranty: None

- Provides storage for fourteen 305 x 610 mm (12 x 24 in) wire baskets
- During cylinder head rebuild, storage space is required for small items like valves, springs, etc.



## 5P-1762 Support Bracket

Model: 3304 and 3306

Warranty: Six Months

Part Number	Description
5P-1762	Support Bracket

- Used to support fan drive bracket when cylinder head is removed from chassis



## FT0117 Seal Ferrule Assembly Tool

Model: All Cat® Engines

Warranty: None

- Used to speed up assembly of cylinder head ferrules and seals

Item	Description
1	Pin
2	Spring
3	Flat Washer
4	Chain
5	Upper Rod
6	Connecting Pin
7	Bracket
8	Connecting Joint
9	Lower Rod
10	Base
	A. Rubber Seals
	B. Ferrule

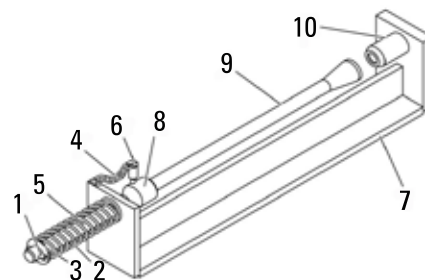

## FT0806 Cylinder Head Repair Bench

Model: All Cat® Engines

Warranty: None

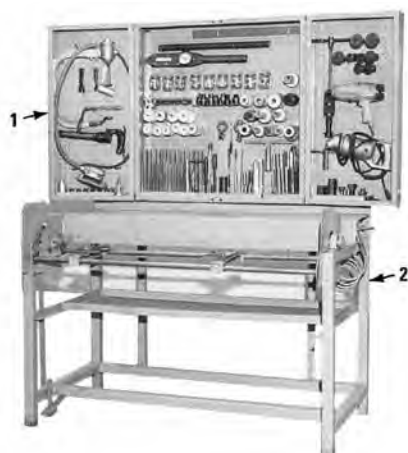

- Provides cradle which will mount all Cat® cylinder heads
- Cradle is well balanced and supported by ball bearings
- Foot-operated release mechanism enables serviceman to turn cylinder heads with ease

Item	Part Number	Description
2	FT0806	Repair Bench
Clamps used to service 3208 and 3406 cylinder heads		
	FT1660	Clamp
	FT1661	Clamp
	FT1662	Clamp

Item	Part Number	Description
1	9S-9087	Tool Cabinet (for illustration purposes)

## 5P-8703 Insert

Model: D353 Engine

Warranty: Six Months



- Required to modify former D353 cylinder heads for spacer plate blocks
- Quantity: 12

Part Number	Description
5P-8703	Insert

### Reference

SMHS7339, Special Instruction

## 6V-9050 Stud Removal Tool Group

Model: 3200, 3300, 3400, C9, C15, C-16, C18, C27, C32

Warranty: Six Months



- Designed to remove broken exhaust manifold studs and bolts
- Consists of drill fixture, 2 alignment bushings, 2 drill bushings, and 2 drills
- Removal of broken stud begins by using disc grinder to grind broken stud so 164-3755 Drill Fixture can be secured to cylinder head; 1/8 inch drill and drill bushing first used to drill completely through broken stud; then stud is drilled out using 5/16 inch drill and drill bushing
- Since bolts are used to retain exhaust manifolds on 3200 Family Engines, HeliCoil is acceptable for repair of these heads; however, studs with taperlock threads are used to retain exhaust manifolds on 3300 and 3400 Family Engines and HeliCoil cannot be satisfactorily used to repair cylinder heads on these engines.

### Reference

SMHS8297, Special Instruction

Item	Part Number	Description
1	6V-3073	Case - Plastic
2	6V-4094	Foam - Convolutated
3	6V-9051	Block

Item	Part Number	Description
4	5P-7330	Screw
4	164-3755	Fixture

(Continued)

## 6V-9050 Stud Removal Tool Group (Continued)

Model: 3200, 3300, 3400, C9, C15, C-16, C18, C27, C32

Warranty: Six Months

Item	Part Number	Description
5	164-3756	Alignment Bushing, 9.53 mm (0.375 in) diameter (2 piece)
6	0S-1588	Bolt
7	164-3757	Drill Bushing, 7.94 mm (0.312 in) diameter

Item	Part Number	Description
7	164-3758	Drill Bushing, 3.18 mm (0.125 in) diameter
8	5P-6732	Screw
9	6V-9048	Drill, 7.94 mm ( 5/16 in) outside diameter
9	6V-9049	Drill, 3.18 mm ( 1/8 in) outside diameter
--	6V-9050	Stud Removal Tool Group

## 188-3922 Exhaust Stud and Bolt Removal Tool Group

Model: 3114, 3116, 3126, 3126B, 3176, 3176B, 3196, C7, C-10, and C-12 Engines

Warranty: Six Months

- Used to remove broken metric exhaust bolts and studs from engines
- Designed for drilling out studs/bolts to minimum thread diameter — remaining pieces of thread can be removed and threads cleaned up with a tap
- Can be used with engine still installed in machine/vehicle
- Includes a drilling plate, alignment bushings, drill bushings, and drill bits

### Reference

NEHS0787, Tool Operating Manual

Item	Description
11	NEHS0787 Tool Operating Manual
Not Shown	NEEG2895 Decal

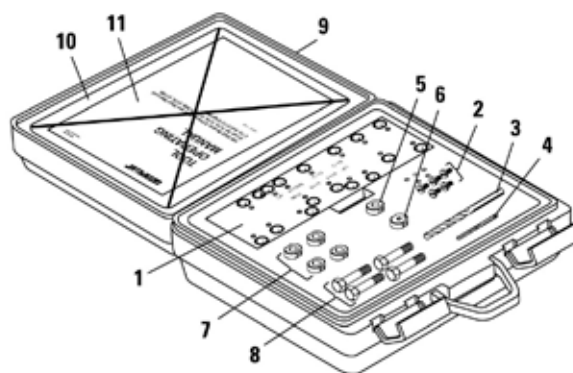

Item	Part Number	Description	Qty.
1	188-3914	Drilling Plate	--
2	188-3915	Bushing Lock Screw	5
3	1U-8163	Drill, 8.5 mm (0.334 in)	--
4	1U-8133	Drill, 2.5 mm (0.098 in)	--
5	188-3923	Bushing, 8.5 mm (0.334 in) inside diameter	--
6	188-3918	Bushing, 2.5 mm (0.098 in) inside diameter	--

Item	Part Number	Description	Qty.
7	188-3916	Bushing, 10 mm (0.393 in) inside diameter	4
8	8T-4186	Bolt, M10 x 1.5, 40 mm (1.57 in) long	4
9	6V-3072	Case - Plastic, NEEG2574 Group Decal on lid (9U-7402 Group)	--
10	188-3921	Foam Insert	--
--	188-3922	Exhaust Stud and Bolt Removal Tool Group	--

## 357-4646 Drilling Plate

Model: 3054 Engines  
Warranty: Six Months

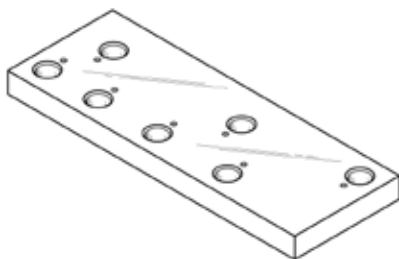

- Used to remove broken exhaust manifold studs and bolts from engine
- Used with 188-3922 Exhaust Stud and Bolt Removal Group
- Used in place of 188-3914 Drilling Plate
- Designed to attach to exhaust manifold and exactly locate drill bits when drilling out broken studs/bolts
- Can be used with engine still installed in machine/vehicle
- Black-oxide coated for corrosion resistance

### Reference

NEHS0787, Tool Operating Manual

Part Number	Description
367-4646	Drilling Plate

## 350-8688 Drilling Guide Plate

Model: C11 Engine, C13 Engine  
Warranty: Six Months

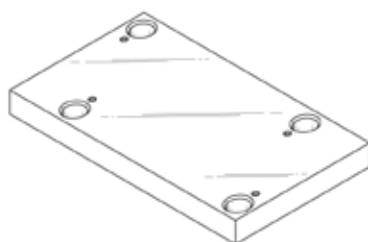

- Used to remove broken exhaust manifold studs and bolts from engines
- Used with 188-3922 Exhaust Stud and Bolt Removal Group
- Used in place of 188-3914 Drilling Plate
- Designed to attach to exhaust manifold and exactly locate drill bits when drilling out broken studs/bolts on C11 and C13 engines
- Can be used with engine still installed in machine/vehicle
- Reversible design to fit both sides of engine
- Black oxide coated for corrosion resistance

Part Number	Description
350-8688	Drilling Guide Plate

### Reference

NEHS0787, Tool Operating Manual,  
188-3922 Broken Bolt and Stud Removal Group



## FT1766 Pilot Adapters

Model: All Cat® Engines

Warranty: None

- Can be installed in cylinder head and used as guide when surface is ground
- Can be made in 3 different sizes which will fit all Cat® cylinder heads equipped with precombustion chambers or nozzle adapters
- Can be used with valve seat grinding tools which use 9.53 mm (0.375 in) diameter pilot

### Reference

SMHS8276, Special Instruction



## 6V-7028 Spring Seat Enlarger

Model: All Cat® Engines

Warranty: Six Months

Part Number	Description
6V-7028	Spring Seat Enlarger

- Used to machine larger spring seat diameter on 9N-1107 Cylinder Heads; larger spring seat necessary to install large diameter valve springs and spacers
- Must be used with 12.7 mm ( 1/2 in) electric drill (500 to 700 RPM)

### Reference

SEHS8131, Special Instruction



## Fabricated Tools for Batch Processing Cylinder Heads

Model: 3204, 3208

Warranty: None

- Used to decrease reconditioning time of cylinder heads
- Especially helpful when large quantities of cylinder heads are reconditioned (batch processing)

Item	Part Number	Description
1	FT1654	Plug Driver
2	FT1655	Plug Driver
3	FT1656	Cylinder Head Thickness Gauge
4	FT1660	Head Bench Clamp
5	FT1661	Head Bench Clamp
6	FT1662	Head Bench Clamp
7	FT1712	Valve Retainer
8	FT1721	Valve Seat Cutter Set Gauge
9	FT1722	Valve Lock Remover
10	FT1739	Cylinder Head Wash Rack
11	FT1753	Valve Stem Protector
12	FT1779	Holding Fixture

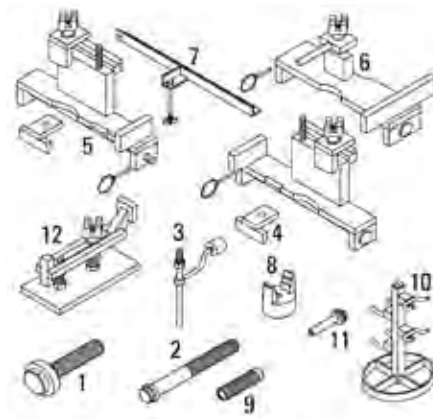

## 375-2773 Installation Tool

Model Usage: C13 & C15 Engines

Warranty: Six Months



- Used to install valve seal using hand pressure
- Prevents damage to valve seal during installation

Specifications	
Dimensions	150 x 26.8 mm (5.90 x 1.05 in)
Weight	.54 kg (1.20 lbs)
Material	Steel

Part Number	Description
375-2773	Installation Tool

## 4C-6373 Valve Seal Installer

Model: 3046 Diesel Engine

Warranty: Six Months



- Used to install valve seal — easily installed using hand force
- Prevents damage to valve seal during installation — saves time and reduces cost
- Knurled for ease of handling

Part Number	Description
4C-6373	Valve Seal Installer

### Reference

SENR6458, Special Instruction, Disassembly and Assembly of 3046 Engine

## Cylinder Condition Analysis Tools

Model: All Models

Warranty: Six Months



- Used to analyze cylinder condition on any Cat® engine
- Pressurized air is introduced into cylinder; amount of pressure drop is indicator of piston ring and valve condition

### Reference

GMG00694, Special Instruction

Item	Description
4	Norgren Regulator Model #11-002-049

(Continued)

## Cylinder Condition Analysis Tools (Continued)

Model: All Models

Warranty: Six Months

Item	Part Number	Description
1	6K-5875	Hose Assembly
2	1P-5564	Adapter (D.I. Engines)
3	1P-5565	Adapter (Gas Engines)
5	3B-7767	Nipple (Modify nipple by filling with braze and drilling a 1.02 mm (0.04 in) orifice hole through braze)
6	3B-7762	Tee Fitting
7	6V-4142	Nipple, Unvalved (for 42000 kPa)

Item	Part Number	Description
8	9S-7341	Fitting [6.35 mm ( 1/4 in) tube, 3.175 mm ( 1/8 in) pipe]
9	8S-2268	Tube Assembly
10	6V-4143	Coupler Assembly
10	7S-8897	Seal
11	8T-0846	Pressure Gauge
12	1P-5569	Tip
13	1P-5567	Tip
<b>Not Shown</b>		
--	5K-5068	Nipple - Pipe Hexagon

## 9U-7995 Head Guide Pin

Model: 3046 Diesel Engine

Warranty: Six Months

Part Number	Description
9U-7995	Head Guide Pin

- Used to align cylinder head during engine assembly — two required
- Simple to use (threaded guide pin has screwdriver slot for easy installation)
- Thread: M12 x 1.75
- Overall length: 115.0 mm (4.5 in)



### Reference

SEN6458, Special Instruction, Disassembly and Assembly of 3046 Engine

## 312-2840 Socket (Head and Flywheel Bolt)

Model: C175

Warranty: Six Months

Part Number	Description
312-2840	Socket (Head and Flywheel Bolt)

- Used to remove and install cylinder head and flywheel bolts
- Used with 3/4 inch drive standard and torque wrenches
- Do not use with impact wrench
- Heavy-duty, twelve-point socket properly fits M16 Bolts (24 mm across flats)

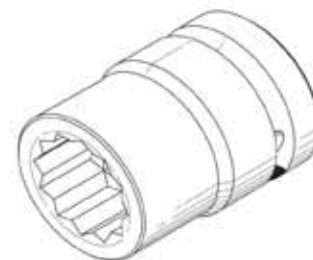

### References

KENR6052, Service Manual, C175-16 and C175-20 Engine, Disassembly and Assembly

REN7466, Service Manual, C175-16 Generator Engine Sets, Disassembly and Assembly

## 359-4208 G3500 Valve Seat Removal Tool

Model Usage: G3500

Warranty: Six Months



- Safely removes valve seats from Gas 3500 engines
- Eliminates insert breakage
- Reduces repair time
- Reduces rework due to broken inserts

Specifications	
Hydraulic Source Requirements	68.9 kPa (10,000 psi)
Dimensions	355.6 x 228.6 x 190.5 mm (14 x 9 x 7.5 in)
Weight	8.85 kg (19.5 lbs)

Part Number	Description
359-4208	G3500 Valve Seat Removal Tool
Service Parts	
371-0351	Cylinder-Puller
359-4286	Collet As.
359-4287	Drawbar
359-4288	Washer
361-0074	Slide-lower

Electrical and Ignition Tools

**FT1031 Bearing Driver**

Model: Prestolite Starters  
 Warranty: None

- Used to properly install Oilite bearings in Prestolite starting motors
- Act as insertion and sizing tool during installation of bearings
- Driver does not destroy bearings self-lubricating qualities

**Reference**

FM035064, Special Instruction

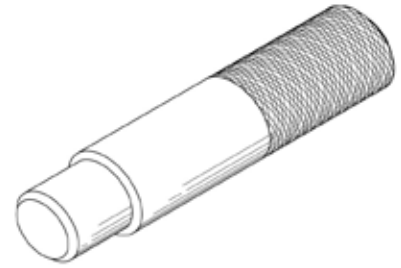

**9U-7226 Installer Group**

Model: 3406E Engine  
 Warranty: Six Months

- Used to install valve stem seals — easily installed using hand force
- Prevents installation damage to valve stem seals
- Seals can be installed with cylinder head on or off the engine
- Knurled handles for better grip and zinc-coated to prevent corrosion
- Diameter: 22.2 mm (0.87 in)
- Overall length: 140.0 mm (5.5 in)

**Reference**

SENR5580, Service Manual

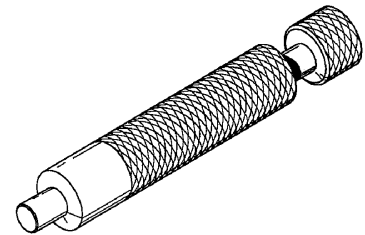

Part Number	Description	Diameter	Overall Length
9U-7226	Valve Seal Installer Group	22.2 mm (0.87 in)	140 mm (5.5 in)

**FT2396 Magneto Wrench**

Model: 3406 Spark Ignited Engines  
 Warranty: None

- Used to disassemble and assemble magneto drive (holds bolt head through mounting hole while tightening magneto drive group)
- Fabricate tool from 4C-9602 Combination Wrench, 23.81 mm (15/16 in), or similar 23.81 mm (15/16 in) combination wrench

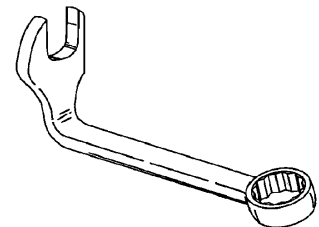

## 1P-2977 Alternator Pulley Tool Group

Model: Delco-Remy Alternators

Warranty: Six Months



- Used to remove pulley retaining nut on shaft of Delco-Remy 20-SI and 25-SI Series Alternators

Item	Part Number	Description
--	1P-2977	Alternator Pulley Tool Group
1	1P-7363	Seal (2)

## FT0753 Bearing Insert

## FT0754 Bearing Insert

Model: Delco-Remy Alternators

Warranty: None

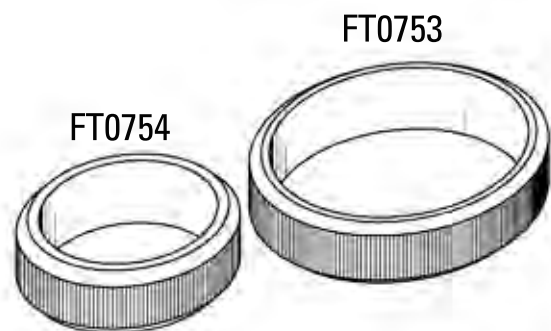

- If alternator bearings fail, 1S-2584 and 1S-2585 End Frames can be salvaged by fabricating FT0753 and FT0754 inserts to replace damaged sleeves

## FT1696 Wrench, FT1697 Socket

Model: Multiple Engine Models

Warranty: None

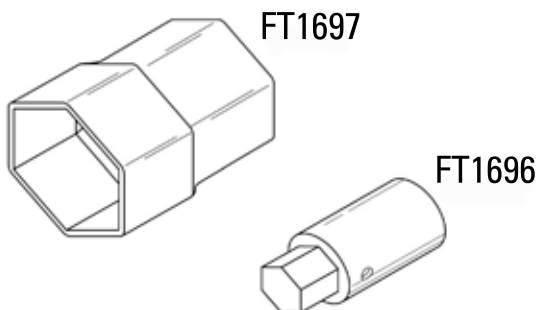

- Two alternator pulley nut tools can be fabricated to tighten the nut for the alternator pulley on 613 and 615 Tractor Scrapers

### 398-6915 Mounting Ring Socket Wrench

Model Usage: Various

Warranty: Manufacturer's

- Used to tighten retaining nut on Emergency Stop Push Button assembly 109-6507 with 124-3176 Guard
- Double ended wrench can be used for 18 mm (.71 in) and 30 mm (1.2 in) pilot light mounting rings



Specifications		
Part Number	Description	Dimensions
398-6915	Mounting Ring Socket Wrench	101.6 x 35.3 mm (4.0 x 1.4 in)

### 1P-5559 Spark Plug Adapter Wrench

### 2P-5481 Spark Plug Wrench

Model: 5.4 inch Bore Natural Gas Engines

Warranty: Six Months

- Used to remove spark plugs and adapters on 137.2 mm (5.4 in) Bore Natural Gas Engines (G342, G353, G379, G398)
- Especially useful because plugs and adapters are deeply recessed in top of engine
- 1P-5559 Wrench:  
Large end: 31.75 mm (1.25 in)  
Small end: 19.05 mm (0.75 in)



Part Number	Description
2P-5481	Spark Plug Wrench
1P-5559	Spark Plug Adapter Wrench

### 176-7129 Terminal Removal and Installation Tool Assembly

Model: All G3500 Non-CSA Electronic Ignition Engines

Warranty: Six Months

Part Number	Description
176-7129	Terminal Removal and Installation Tool Assembly

- Used to remove and install 169-4290 Terminal without removing 169-4295 Extension
- Saves time and money
- Threads easily into terminal
- Design permits quick replacement if shaft [127 mm (5 in) long] breaks during service
- For removal: 1) insert shaft through spring and thread three revolutions into terminal; 2) pull terminal out
- For installation: 1) screw terminal onto shaft; 2) insert through extension; 3) snap onto transformer head; 4) loosen shaft from terminal

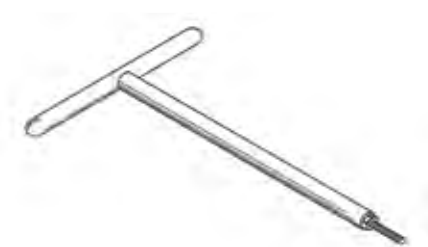

## 132-8263 Terminal Spanner Wrench

Model: All G3500 and G3600 EIS Engines

Warranty: Six Months

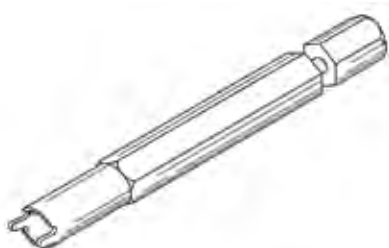

- Used to install and remove 127-8893 Terminal Assembly
- Required to allow proper torquing of terminal assembly ( $2.70 \pm 0.25$  N-m,  $24.0 \pm 2.2$  in-lb)
- Accurate torque is essential to avoid damage to terminal components; necked-down diameter minimizes chance of over-torque

Part Number	Description
132-8263	Terminal Spanner Wrench

## FT1780 Removal and Installation Tool

Model: 3400 Series Spark Ignited Engines

Warranty: None

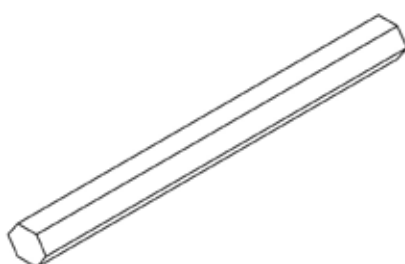

- Needed to remove and install 213-7539 Spark Plug Adapter Assemblies
- Fabricated from 28.6 mm (1.125 in) hexagonal steel rod with sufficient length to reach adapters
- Minimum yield strength of steel: 689,500 kPa (100,000 psi)

## 235-9751 Spark Plug Driver Adapter Assembly

### Essential Tool

Model: G3500C Engines

Warranty: Six Months

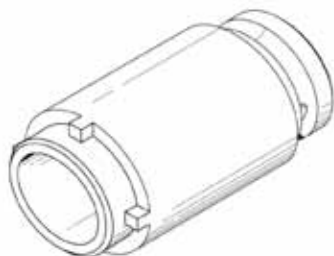

- Used to remove and install 225-0902 Adapter (spark plug)
- Used with 19.05 mm (3/4 in) ratchet
- Built-in pilot for easy engagement

Part Number	Description
235-9751	Spark Plug Driver Adapter Assembly



### 9U-7516 Spark Plug Gauge

Model: 3300, 3400, 3500, and 3600 Spark Ignited Engines

Warranty: Six Months

- Used to check spark plug gap on spark ignited engines
- Compact size — easy to carry from job to job
- Gap wires are retractable — prevents damage when not in use
- Gauge has 2 of each size wires (4 sizes in all)

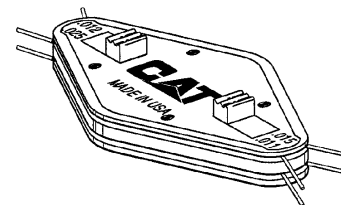

Engine Application	Spark Plug Gap
3600	0.279 mm (0.011 in)
3600 Ionization probe	0.635 mm (0.025 in)
3500	0.279 mm (0.011 in)
3400	0.381 mm (0.015 in)
3400 J-gap	0.304 mm (0.012 in)
3300	0.635 mm (0.025 in)

Part Number	Description
9U-7516	Spark Plug Gauge

### FT2449 Indicator Bracket

Model: 3516 Locomotive Engine

Warranty: None

- Used to check engine to generator alignment
- Threads into hole on main traction generator drive shaft
- Allows 2 alignment readings to be taken at the same time — 1 indicator reads outer coupling diameter and 1 reads coupling face

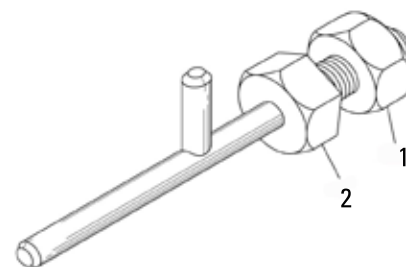

Item	Part Number	Description
1	4K-0367	Nut - Full
2	7X-0344	Bolt, 5/8 - 11

### 192-7039 Driver Assembly

Model: DV096 Generator Set

Warranty: Six Months

- Used to install shaft seal for auxiliary water pump
- Used with hammer and suitable driver with 6.4 mm (0.25 in) pilot
- Drive installer onto shaft until OD of tool contacts housing
- Saves time during pump overhaul by installing seal at exact location every time (eliminates guess work)



#### Reference

Generator Service Manual

Part Number	Description
192-7039	Driver Assembly

## 225-8266 Clamp On Ammeter

Model: All

Warranty: Manufacturer's One Year

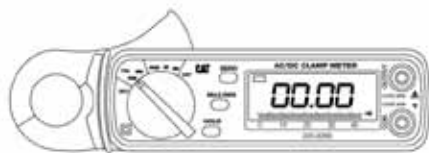

European Union compliant, CE marked

- Used to measure AC or DC current
- Compact size and low cost make this unit indispensable
- Clamp-on probe replaces standard test leads (allows current measurements without breaking circuit)
- Measures current in cables up to 23 mm (0.9 in) diameter
- User selectable 400 ampere and 1200 ampere scales for both AC and DC
- Powered by two 1U-9533 AA Alkaline Batteries
- Designed with a built-in display, push button zero control for DC operation, "display hold" to freeze display, "max/min recording" to display highest and lowest readings, auto power-off (unit turns off automatically after 30 minutes), and low battery indicator
- Shipped with batteries, carrying case, and users guide

### Repair Information

Extech Instruments

9 Townsend West

Nashua, NH 03061

Ph: (781) 890-7440, ext: 220

Fax: (781) 890-7864

Email: repair@extech.com

Weight	190 g (6.7 oz)
Overall size	183 x 61 x 36 mm (7.2 x 2.5 x 1.4 in)
Resolution	1 A

Part Number	Description
225-8266	Clamp On Ammeter (400, 1200 A ranges)
<b>Service/Repair Parts</b>	
1U-9533	AA Alkaline Battery , non-rechargeable, package qty 96 (5 required to power Indicator III)
6V-6014	Cable

## Carrying Case and Accessories for Discontinued 8T-0900 Clamp-on Ammeter

Warranty: Six Months



Item	Description
3	Form SEHS8026 "Electrical Test Kit"

Item	Part Number	Description
1	6V-3072	Case - Plastic, NEEG2574 Group Decal on lid (9U-7402 Group)
2	6V-6040	Foam Insert
4	6V-6014	Cable
5	6V-7070	Digital Multimeter

Lube System

**175-7546 Oil Filter Cutter Group**

Model: All Models

Warranty: Six Months

- Used to cut open spin-on filters to inspect filter media for contaminants, a common practice when diagnosing potential machine problems and internal contaminants.
- Aluminum frame construction
- Designed to cut all types of filters, including aircraft-style filters, without repositioning cutting wheels
- Heavy-duty double roller and cutting wheel design eliminates binding of filters
- All wear parts are heat-treated steel for added durability
- Cutting wheels are ground with a double-taper edge for easier cutting



Engine Tools

Item	Part Number	Description	Required
--	175-7546	Oil Filter Cutter Group	--
1	177-0364	Roller	2
2	177-0365	Cutting Wheel	2
3	177-0367	Pin	4
Not shown	177-0366	Spacer	2

**373-4824 Oil Filter Housing Extension Tube Seal Installer**

Model Usage: CT660 Truck

Warranty: Manufacturer's

- Used to properly install the extension tube seals in the oil filter housing

Specifications	
Dimensions	177.8 x 139.7 x 127.0 mm (7.0 x 5.5 x 5.0 in)
Weight	0.43 kg (0.94 lb)

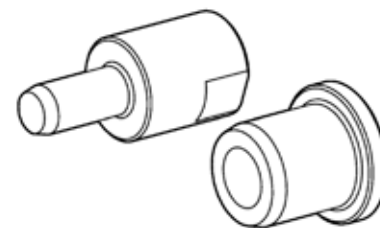

Part Number	Description
373-4824	Oil Filter Housing Extension Tube Seal Installer

**373-4830 Oil Cooler Test Plates**

Model Usage: CT660 Truck

Warranty: Manufacturer's

- Used to pressure test the oil cooler

Specifications	
Dimensions	5 x 4 x 2 in
Weight	0.5 lbs

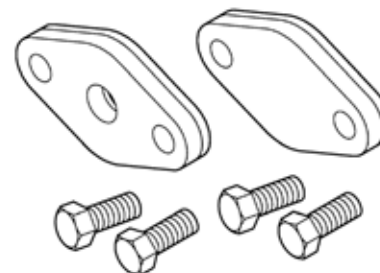

Part Number	Description
373-4830	Oil Cooler Test Plates

## 371-4330 Oil Filter Drainer Group

Model Usage: Any Engine Application

Warranty: Six Months



- Used to cleanly drain an oil filter before removal from engine
- Designed to puncture a hole in side of the inverted oil filters to allow easy oil drainage
- Do not remove oil filter from engine until oil has been completely drained into oil storage container
- Equipped with 101.6 – 165.1 mm (4 - 6 ½ in) attached clamp

Specifications	
Dimensions	64 x 35 x 31.75 mm (2.52 x 1.38 x 1.25 in)
Weight	69.0 kg (1.51 lb)

Part Number	Description
371-4330	Oil Filter Drainer Group

## 4C-5084 Spin-on Oil Filter Cutter

**Discontinued — Service Parts Available**

Warranty: Six Months

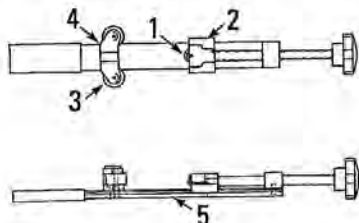

### Reference

SEHS9160, Special Instruction

Item	Description
5	NEEG2002 Decal (not shown)

Item	Part Number	Description
--	4C-5084	Spin-on Oil Filter Cutter
1	5P-4811	Cutting Wheel
1	133-5633	Spacer Insert
1	9U-5354	Shoulder Screw
2	9U-5356	Saddle
3	9U-5353	Roller
4	9U-5355	Roller Bracket

### 4C-6780 Bushing Removal Tool Group

Model: 3208 Engines  
 Warranty: Six Months

- Removes oil pump bushing fast without damaging timing gear cover
- Works on both naturally aspirated and turbo-charged engines
- Marked for each engine for easy use

Item	Part Number	Description
--	4C-6780	Bushing Removal Tool Group
<b>Service/Repair Parts</b>		
1	4C-6781	Bushing Removal Guide
2	4C-6782	Bushing Removal Punch

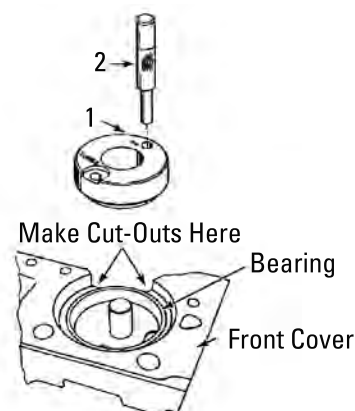

### FT0977 Oil Pump and Pan Removal and Installation Tool

Model: 992 Engine  
 Warranty: None

- Used to remove oil pump and pan as a unit on 992
- Material: SAE 1020 steel

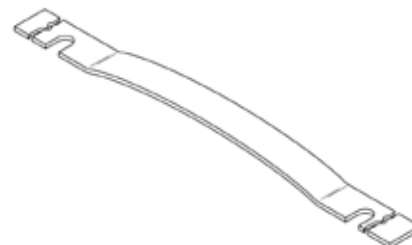

### 9S-9273 Coupler

#### 9S-9274 Plug

Model: D8H, 583H, D9G, DD9G, 594  
 Warranty: Six Months

- Coupler is quick disconnect adapter for equipment that services high speed oil change attachment groups; high speed oil change groups provide convenient method for both fill and evacuation of engine crankcase oil, and a compatible quick disconnect coupler is essential for service equipment that supplies and evacuates oil
- Minimal chance for airborne contaminants to enter engine during oil changes with high speed oil change arrangement
- Three different nipples are used in various attachment groups; 9S-9273 Coupler accommodates all three; steel cable lanyard provided for disconnecting coupler from nipple
- 9S-9274 Plug Assembly used to protect coupler from dirt and other contaminants when not in use
- Easier for customer to meet local regulations concerning oil spillage; leakproof seal created when coupler connected to nipple; also, no leakage occurs when coupler engages nipple or when connection is broken



(Continued)

## 9S-9273 Coupler (Continued)

### 9S-9274 Plug

Model: D8H, 583H, D9G, DD9G, 594

Warranty: Six Months

- Has 41.3 mm (1.62 in) hex for installing 3/4 inch-14 NPTF threaded end into service hose fitting

Length	70.6 mm (2.78 in)
Diameter	50.8 mm (2.00 in)

Item	Part Number	Description
1	9S-9273	Coupler
Not shown	9S-9274	Plug Assembly
2	1P-7919	Nipple, Bulkhead 37 degree Male, 1 1/16 - 12 thd
Not shown	8T-5373	Nipple, Face Seal Male, 1 3/16 - 12 thd
Not shown	9S-9271	Nipple, 3/4 - 14 NPTF thd Male
Not shown	9S-9272	Cap Assembly (for the 3 nipples)

## 246-4268 Coupler Rework Fixture Group

Model: 3524B Engine

Warranty: Six Months

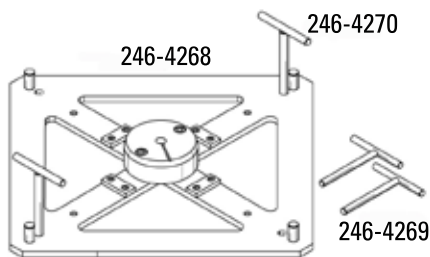

- Used to disassemble and assemble 3524B Engine coupling group
- Used with two 246-4269 Positioning Pin Assembly and two 246-4270 Positioning Pin Assembly (part of group)
- Allows replacement of individual parts rather than entire group
- Mounts easily on 1P-2420 Transmission Repair Stand using four FT0996 Positioning Legs

Part Number	Description
246-4268	Coupler Rework Fixture Group

### Reference

REN2276-02, 3524B Engine Service Manual, Disassembly and Assembly

## 201-2592 Bit

Model: MY2000, C-15, and C-16 Engines

Warranty: Six Months

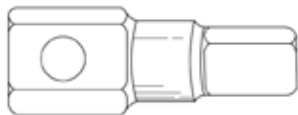

- Special 5/16 inch bit used to remove the square socket oil gallery pipe plugs
- Used with standard 7/16 inch socket and ratchet

Part Number	Description
201-2592	Bit

Male hex	7/16 in
Male square	5/16 in
Overall length	32 mm (1.25 in)

### 301-0285 Alignment Tool

Model Usage: C1.5 and C2.2 Engine

Warranty: Six Months

- Properly orients the oil pump to the engine block
- Provide protection of the oil pump during the installation process

**Reference:**

KENR9149, KENR6948, KENR6229

Part Number	Description
301-0285	Alignment Tool

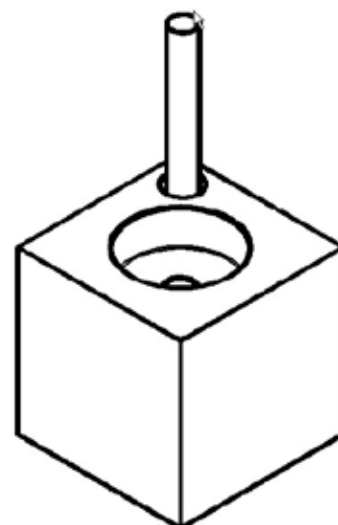

### 385-8485 Dowel Driver

Model Usage: C175

Warranty: Six Months

- Used to insert new oil dowel (371-6466) into C175 Block
- Does not distort dowel during installation

385-8485 Specifications	
Dimensions	153 x 20 mm (6.02 x 0.79 in)



### 126-7538 Transmission Oil Nozzle Assembly

### 126-7539 Crankcase Oil Nozzle Assembly

Model: Multiple Engine Models

Warranty: Six Months

- Used to attach hose of high speed oil change equipment onto component being serviced on D8R Track-Type Tractor (provides leakproof connection when installed)
- Nozzles help customers to more effectively meet local regulations concerning oil spillage
- Using high speed oil change equipment provides fast and convenient way to fill and drain oil from components

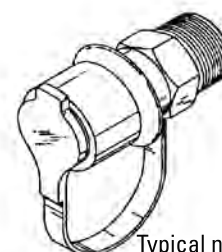

Typical nozzle assembly

Part Number	Description	Length	Diameter	Thread Size	Hex Size	Installed To	Used with
126-7538	Nozzle Assembly	78.7 mm (3.10 in)	48.5 mm (1.91 in)	3/4 -14 NPTF	33.3 mm (1.31 in)	transmission case oil drain	110-8319 Receiver Assembly
126-7539	Nozzle Assembly	83.8 mm (3.30 in)	54.6 mm (2.15 in)	3/4 - 14 NPTF	38.1 mm (1.50 in)	engine crankcase oil drain	110-8827 Receiver Assembly

## Engine Test Tools

Engine Tools

### FT0949 Dynamometer Adapter Storage Rack FT0940 Water Line Adapter, FT0941 Hose Hanger

Model: All Vehicle Engine Models

Warranty: None

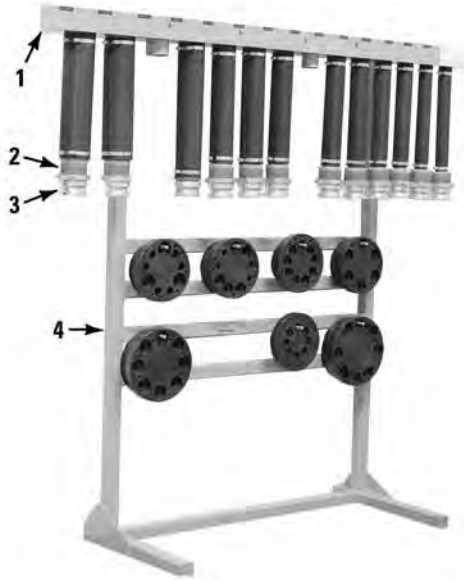

- 2 sets of FT0940 Adapters needed to adapt standard size quick disconnect couplings into water lines between cooling tower and any Cat® engine; one end of adapter connects to male half of quick disconnect coupling; other end sized to fit engine water hose
- FT0941 Hose Hanger used to store complete set of quick disconnect-type water lines for dynamometer testing Cat® engines; can be mounted on FT0949 Storage Rack

Item	Part Number	Description
1	FT0941	Hose Hanger
2	FT0940	Adapter
3		Quick Disconnect Coupling
4	FT0949	Storage Rack



### FT0790 Cooling Tower Group

Model: All Vehicle Engine Models

Warranty: None

- Efficient, economical means for engine cooling for dynamometer installations
- Many parts available from Parts Department; some must be purchased locally; Bill of Material which includes some fabricated items given below; for complete details of construction, request drawings FT0790, FT0789, FT0788, and FT0955

Item	Part Number	Description
8	FT-0955	Adapter
13	FT-0788	Adapter
17	FT-0789	Stand
22	7L489	Heat Exchanger Assembly

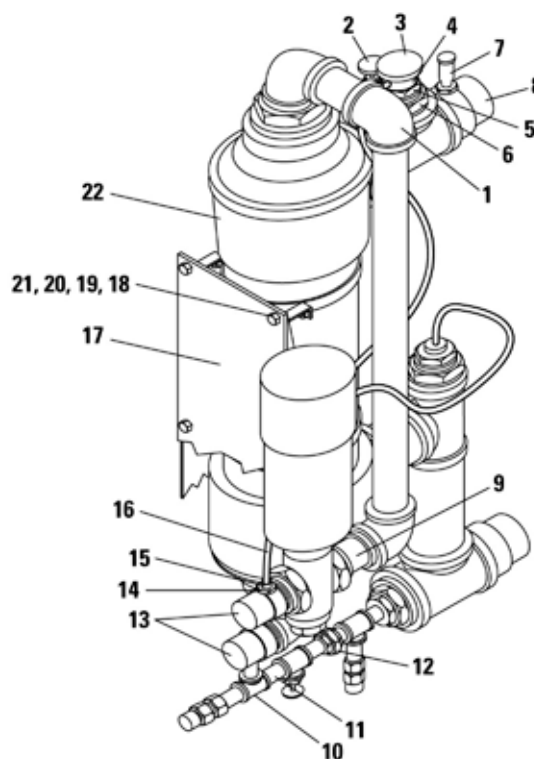

Item	Part Number	Description
1	7B-7138	Street Elbow 90°
2	7B-9684	Globe Valve
3	2S-3080	Cap Assembly
4	3S-5546	Neck
5	2F-5277	Reducing Bushing
6	5L-6669	Reducing Bushing
7	7F-6785	Thermometer
9	3B-7296	Close Nipple (2 in NPT)
10	5B-8979	Tee

Item	Part Number	Description
11	3B-7866	Nipple
12	7B-9685	Pipe Union
14	8B-1931	Reducing Bushing
15	4S-8386	Copper Tubing
16	4S-8759	Vinyl Tube
18	0S-1621	Bolt
19	3B-4508	Lock Washer
20	1D-4719	Nut
21	4B-4280	Washer

### Flywheel Adapters for Dynamometer Testing

Model: Most Vehicle Engine Models

Warranty: Six Months

- Adapters can be fabricated to mount entire line of Cat® engines to either Clayton or Taylor Dynamometers

## Tractors

Model	Serial number	Adapter
D3	6N, 79U, 83U	FT0730-4
D4	6U, 7U	FT0720-01
D4C	39A, 40A, 54A, 55A	FT0719-2
D4D	67A, 78A, 88A, 91A, 22C, 97F, 44H, 18J, 20J, 49J, 58J, 59J, 60J, 61J, 65J, 66J, 82J, 83J, 84J, 69K, 7R	
D4E	27X, 28X, 29X, 70X, 71X	FT0719-2
D5	98A, 81H, 82H, 83H, 84H, 21J, 62J, 63J, 67J, 68J, 93J, 95J, 96J, 97J, 98J, 6R, 12R	
D5B	23X, 24X, 25X, 26X, 43X, 44X, 45X	FT0719-2
D6	8U, 9U	FT0720-01
D6B	37A, 44A, 56A, 57A, 37H, 38H	FT0719-2
D6C	41A, 71A, 73A, 74A, 76A, 82A, 83A, 96A, 90B, 46J, 47J, 56J, 69J, 99J, 10K, 26K, 17K, 69U	FT0719-2
D6D	3X, 4X, 5X, 6X	FT0719-2

## Tractors (Continued)

Model	Serial Number	Adapter
D7	17A	FT0725
D7E	47A, 48A, 75A	FT0725
D7F	91E, 92E, 61G, 93N, 94	FT0719-2
D7G	64V, 91V, 92V, 72W	FT0719-2
D8	113A, 14A, 15A	FT0724-2
D8H	22A, 35A, 36A, 46A, 68A	FT0724-2
D8K	76V, 77V	FT0724-2
D9	18A, 19A, 49A, 50A	FT0722-1
D9	34A	FT0724-2
D9G	66A, 90J, 91J, 29N, 30N	FT0724-2
D9H	90V	FT0724-2
D10	84W	FT1776-1

**Pipelayers**

Model	Serial Number	Adapter
561B	62A	FT0719-2
561C	85H, 92J	FT0719-2
561D	54X	FT0719-2
571A	64A	FT0725
571F	95N	FT0719-2
571G	16W	FT0719-2
572E	21A, 65A	FT0725
572F	96N	FT0719-2
572G	40U	FT0719-2
583C-E	16A	FT0724-2
583H	38A, 61A	FT0724-2
583K	78V	FT0724-2
594	62H	FT0724-2
594H	96V	FT0274-2

**Track-Type Loaders**

Model	Serial Number	Adapter
931	10N, 78U, 81U	FT0730-4
933C-E	11A	FT0728
933F-G	25A, 42A	FT0717-1
941	70H, 75H	FT0719-2
941B	80H	FT0719-2
943	3Y, 31Y, 4Z	FT1617
951	89A, 63K	FT0719-2
951B-C	15F, 32F, 19H, 69H, 79H, 72J, 86J	FT0719-2
953	76Y, 5Z	FT1617
955C-E	12A	FT0720-01
955F	51A	FT0719-2
955H	60A, 72A, 77A, 93A	FT0719-2
955K	48H, 61H, 31J, 64J, 85J	FT0719-2
955L	71J, 13X	FT0719-2
977	20A	FT0720-01
977H	53A	FT0719-2
977K	46H, 76H, 48J, 70J, 11K	FT0719-2
977L	48J, 70J, 14X	FT0719-2
983	38K	FT0775-2

**Excavators**

Model	Serial number	Adapter
215	96L	FT0719-2
215	57X	FT1617
225	51U, 61X	FT1730-4
225	20S, 76U	FT0719-2
235	32K, 62X, 81X	FT0719-2
245	95V	FT1177-3

## Motor Graders

Engine Tools

Model	Serial Number	Adapter
12	80C, 70D, 71D	FT0720-01
12E	99E, 12F, 21F, 29H, 17K	FT0719-2
12F	73G, 59H, 89H, 13K, 33K	FT0719-2
12G	61M	FT0719-2
14B	64C, 78E	FT0720-01
14C	35F	FT0719-2
14D	96F	FT0719-2
14E	72G, 99G, 12K	FT0719-2
14G	96U	FT0719-2
16	49G <sup>1</sup>	FT0718-1
16G	93U	FT1177-3
112	81C, 3U	FT0720-01
112E	68E, 91G	FT0719-2
112F	46D, 82F, 80J, 89J	FT0719-2
120	89G, 60H, 14K, 35K, 10R, 22R, 90R, 13U	FT0719-2
120G	87V	FT0719-2
130G	74V	FT0719-2
140	11R, 24R, 14U	FT0719-2
140G	72V	FT0719-2
212	79C, 95C	FT0728-1
<sup>1</sup> Use FT0775 Adapter on engines equipped with discontinued 4S-9643 or 9S-7536 (not serviced) Crankshaft Replacement Gear Group		

Tractor-Scrapers

Model	Serial Number	Adapter
DW15	45C, 59C, 70C, 75D, 76D	FT0725
DW20	21C, 57C, 67C, 87E, 88E	FT0725
DW21	58C, 69C, 85E, 86E	FT0725
613	71M	FT0730-4
613B	38W	FT0730-4
619B	89E, 90E	FT0725
619C	61F <sup>1</sup> , 62F	FT0718-1
621	23H	FT0723-1
621B	45P, 35V	FT1177-3
623	52U	FT0723-1
623B	46P	FT1177-3
627	50K, 54K, 68M, 69M	FT0719-2
627B	14S	FT0719-2
630A	52F <sup>1</sup>	FT0718-1
630B	14G1-438 <sup>1</sup> , 14G442 <sup>1</sup> , 14G-1443 <sup>1</sup>	FT0718-1 or FT0775-2
630B	14G439, 14G440, 14G441, 14G444 Up	FT0718-1 or FT0775-2
631A	51F <sup>1</sup>	FT0718-1 or FT0775-2
631B	13G1-3062 <sup>1</sup>	FT0718-1 or FT0775-2
631B	13G-3063	FT0775-2
631C	67M	FT0775-2
631D	24W	FT1177-3
632	14G	FT0718-1
63	44J	FT0775-2
<sup>1</sup> Use FT0775 Adapter on engines equipped with discontinued 4S-9643 or 9S-7536 (not serviced) Crankshaft Replacement Gear Group		

## Tractor-Scrapers (Continued)

Model	Serial Number	Adapter
633C	66M	FT1177-3
633D	25W	FT1177-3
637	64M, 91N, 92N	FT0719-2
637	65M	FT0775-2
637D	26W, 27W	FT1177-3
641	64F1-317	FT0729-1
641	64F318, 41M	FT0727-1
641B	65K	FT0776-1
650	63F	FT0729-1
650	63F, 77F	FT0727-1
650B	58K	FT0776-1
651	33G1-154	FT0729-1
651	33G155, 44M	FT1776-1
651B	67K	FT1776-1
657	31G1-174	FT0729-1
657	31G175, 46M	FT0727-1
657	19G1-357 <sup>1</sup>	FT0718-1
657	19G358	FT0775-2
657B	53K, 47M	FT0775-2
657B	68K	FT0776-1
660	77F1, 123, 90F1, 168	FT0729-1
660	77F124, 90F169	FT0727-1
660B	18G, 58K	FT0776-1
666	32G	FT0729-1
666	77F, 64H	FT0727-1
666B	20G1-119 <sup>1</sup>	FT0718-1
666B	20G120	FT0775-2
666B	66K	FT0776-1

<sup>1</sup> Use FT0775 Adapter on engines equipped with discontinued 4S-9643 or 9S-7536 (not serviced) Crankshaft Replacement Gear Group

## Off-Highway Trucks

Model	Serial Number	Adapter
759	99F1-8431 <sup>1</sup> , 99F850 <sup>1</sup>	FT0718-1
769	99F844	FT0775-2
768	79S	FT0775-2
772	11S, 80S	FT0776-1
773	63G	FT0776-1
776	14H	FT0776-1
777	84A	FT0776-1

<sup>1</sup> Use FT0775 Adapter on engines equipped with discontinued 4S-9643 or 9S-7536 (not serviced) Crankshaft Replacement.

**Skidders**

Model	Serial Number	Adapter
518	50S, 55U, 94U, 95U	FT0719-2
528	51S, 78W	FT0719-2
814	90P, 14R	FT0719-2
815	91P, 15R	FT0719-2
816	57U	FT0719-2
824	29C <sup>1</sup>	FT0718-1
824B	36H1-313 <sup>1</sup>	FT0718-1
824B	36H314	FT0775-2
826B	58U	FT0775-2
834	43E1-313 <sup>1</sup>	FT0718-1
834	43E314	FT0775-2
835	44N	FT0775-2

<sup>1</sup> Use FT0775 Adapter on engines equipped with discontinued 4S-9643 or 9S-7536 (not serviced) Crankshaft Replacement Gear Group

**Wheel Loaders**

Model	Serial Number	Adapter
910	80U	FT0730-4
920	62K, 41J, 75J	FT0719-2
922	63A	FT0716
922	59A	FT0717-1
922B	94A, 74J, 88J	FT0719-2
930	41K, 79J	FT0719-2
944	58A	FT0716
944	43A, 70A, 77J, 87J	FT0719-2
950	90A, 99A, 58H, 15J, 43J, 73J, 81J, 31K, 49U	FT0719-2
966	33A	FT0719-2
966B	75A, 57H	FT0719-2
966C	78G, 76J, 30K	FT0719-2
980	42H	FT0723-1
980B	89P	FT0719-2
988	87A1-13081	FT0718-1
9888	7A-1309	FT0775-2
988B	50W	FT1177-3
992	25K	FT0776-1
992C	42X	FT1177-3

## Engines

Engine Tools

Model	Serial Number	Adpater
D311H	51B	FT0717-1
311	7S, 9S, 4V	FT0728-1
D312	1N	FT0720-01
D315	9S, 4V, 5V	FT0720-01
D315G	48B, 52B	FT0720-01
D318	3V, 5V, 6V	FT0720-01
D318G	45B, 53B	FT0720-01
D320A	63B	FT0717-1
D326	25B, 26B, 27B	FT0725
D326F	39B, 40B	FT0725
D330A	56B, 57B, 85B, 86B	FT0719-2
D330B	81B, 82B, 98B, 99B	FT0719-2
D330C	2B, 4B, 5B, 78P, 48V	FT0719-2
3304		FT0719-2
D333A	58B, 59B, 87B	FT0719-2
D333B	79B, 80B, 84B	FT0719-2
D333C	23C, 66D, 67D, 68D, 28M, 62M, 3N, 70R, 76R273, 62U, 49V	FT0719-2
3306		FT0719-2
D334	92B, 93B	FT0723-1
D336	55B, 60B	FT0723-1
D337	22B, 23B, 24B	FT0725
D337F	37B, 38B	FT0725
D339	34B	FT0725
D342C	31B, 32B, 49B, 50B, 71B, 35J	FT0724-2



Engines (Continued)

Model	Serial Number	Adapter
D343	62B1-5738 <sup>1</sup>	FT0718-1
D343A	33B1-2489 <sup>1</sup>	FT0718-1
D343	62B-5739, 97N	FT0775-2
D343A	33B-2490, 63M	FT0775-2
D346	39J, 40J, 98N	FT0776-1
D348	36J, 38J, 57K, 92R	FT0776-1
D349	61P, 62P, 32R, 93R	FT0776-1
D353	46B1-869, 47B1-469	FT0722-1
D353	468870, 478470	FT0724-2
D353D	64B	FT0724-2
D353DE	77B	FT0724-2
D364	19B, 20B, 21B	FT0726-1
D375	16B, 17B, 18B	FT0726-1
D375D	43B, 44B	FT0726-1
D379A-B	68B, 69B, 72B, 76B	FT0721-2
D386	13B, 14B, 15B	FT0726-1
D397	10B, 11B, 12B	FT0726-1
D397D	41B, 42B	FT0726-1
D398	66B, 67B, 73B, 75B, 34J	FT0721-2
D399	35B, 91B, 49C	FT1176-3
1140	36B	FT0730-4

<sup>1</sup> Use FT0775 Adapter on engines equipped with discontinued 4S-9643 or 9S-7536 (not serviced) Crankshaft Replacement Gear Group

## Engines (Continued)

Model	Serial Number	Adapter
1145	97B	FT0730-4
1150	96B	FT0730-4
1160	95B	FT0730-4
3145	96M, 65P	FT0730-4
3150	97M, 66P	FT0730-4
3160	98M, 67P, 68P	FT0730-4
3204	45V	FT0730-4
3208	90N, 40S, 75V, 79V	FT0730-4
1670	61B	FT0719-2
1673	74B	FT0719-2
1673B	70B, 78B	FT0719-2
1673C	69D, 76R	FT0719-2
1674	94B	FT0719-2
1676	54B	FT0719-2
1693	65B1-493 <sup>1</sup>	FT0718-1
1693	65B494, 27U	FT0775-2
3406	90U, 91U, 92U, 70V	FT1177-3
3408	67U, 99U, 28V	FT1177-3
3412	60M, 38S	FT1177-3
3512	49Y, 50Y, 51Y, 24Z	FT1615

<sup>1</sup> Use FT0775 Adapter on engines equipped with discontinued 4S-9643 or 9S-7536 (not serviced) Crankshaft Replacement Gear Group

## Dynamometer Testing Facilities

Miscellaneous drawings available from Division Service Manager:

### Engine Base Assembly for Dynamometer Room, Miscellaneous Drawing 2002

- Provides details for constructing a very versatile base on which any engine and stand can be secured for dyno testing
- Accomplished by movable tee hooks in permanent floor slots

### Single Base Dynamometer Room, Miscellaneous Drawing 2014

### Double Base Dynamometer Room, Miscellaneous Drawing 2001

- Provide construction details for single and tandem engine dyno test arrangements
- Facilities include a roof-mounted exhaust stack which can be pulled up to ceiling level by means of a winch and cable
- Plans include soundproof doors and acoustical walls and ceiling

## FT1003 Water Line Adapter

Model: All Vehicle Engine Models

Warranty: None

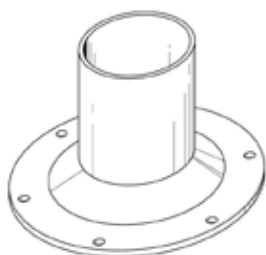

- Used to connect dynamometer cooling line to engine water pump when dyno testing 5.4 inch Bore 60° V-8 Vehicle Engines
- Remove bypass line adapter and regulator housing and bolt adapter directly to water pump
- Material: SAE 1020 steel

### FT1438 Dynamometer Testing Aftercooler

Model: 3176, 3208, 3304B, 3306B, 3406B

Warranty: None

- Air-to-water aftercooler used for dyno testing air-to-air aftercooled engines in 621, 623, 627, 631, 637, 641, 650, 651, 657, 660 and 666 Tractor-Scrapers; 772 and 773 Trucks; and 980 Wheel Loaders
- Designed to maintain 65.56° C (150° F) maximum inlet manifold temperature for engines up to 1000 Hp
- Former FT1198 Test Aftercooler, which was limited to 450 Hp, was discontinued



### 4C-3502 Engine Repair Indicator Kit

Model: All Earthmoving Machines

Warranty: Six Months

- Designed for dealer Product Support Salesmen
- Consolidates many non-technical engine evaluation service tools into convenient, easy-to-carry-and-use kit; includes simple service tools, which measure crankcase pressure, check coolant conditioner and allow for filter inspection
- Allows more accurate check of general engine condition than possible with casual walk-around inspection
- With Engine Overhaul Estimator (ordered separately), allows qualified personnel to predict possible repair options and to recommend improved customer maintenance practices



Consists of 3 parts:

- Non-technical engine evaluation service tools (see consist below) and order form for Engine Overhaul Estimator
- Engine evaluation worksheet which includes guidelines for walk-around inspection of machines engine and cooling system
- Literature discussing proper engine maintenance practices

#### Reference

SEHS9037, Special Instruction

Kit also Includes:
Screwdriver (flat blade)
Water Bottle
SEHS9037 Use of the 4C-3502 Engine Repair Indicator Kit
PEEP7234 Oil Change Labels (English)
PEEP8211 Engine Evaluation Worksheet
SEBD0717 Diesel Fuel and Your Engine
SEBD0518 Know Your Cooling System
PEDP6101 Repair Before Failure Testimonial
PEDP7101 Managing Preventive Maintenance Before Failure
SEBU5596 Identification Number Location Guide
SEBU6250 Caterpillar's Machine Lubricant Recommendations
PEHP9013 Air Filter Indicator Facts Sheet
PEDP7105 Scheduling Oil Sampling
SEBD0640 Oil and Your Engine

Part Number	Description
8T-2844	Temperature Recorder Group
4C-9301	Coolant Test Kit
185-3630	Filter Strap Wrench Assm. <sup>1</sup>

Part Number	Description
239-6825	Ratchet (1/2 in Drive)
9S-1732	Extension -- 127 mm (5.0 in) Long (1/2 in Drive)

(Continued)

## 4C-3502 Engine Repair Indicator Kit (Continued)

Model: All Earthmoving Machines

Warranty: Six Months

Part Number	Description
4C-4732	Filter Minder and Filter Service Indicator
4C-4733	Crankcase Pressure Gauge
4C-4730	Carrying Case
1U-7262	Magnet
8H-8580	Scraper

Part Number	Description
1S-0178	Fitting
5H-8936	Adapter
4C-4731	Block Foam Lower
4C-4729	Block Foam Upper
4C-3502	Engine Repair Indicator Kit

<sup>1</sup>Warranty: Six Months

## 1U-8835 Scale

Model: All Engine Models

Warranty: Six Months

- Optional inch scale used with 8T-0452 Gauge Assembly (slack tube manometer) to check gas pressures such as intake manifold or exhaust back pressure
- Easier to read when inch readings are referenced than standard centimeter scale

Part Number	Description
1U-8835	Scale

## 196-3165 Tool Kit, C-9 Engine

Model: C-9 Engine

Warranty: Six Months

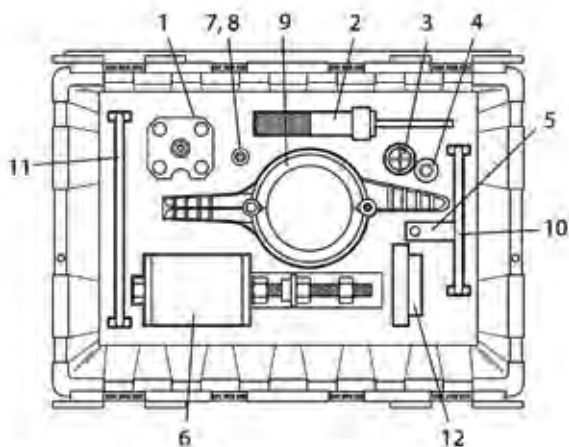

- 196-3165 Tool Kit used to overhaul C-9 Engines (contains all tools unique to this engine)
- 173-5533 Bracket securely attaches C-9 engine to repair stand — bolts to engine using breather assembly mounting holes
- Used with 173-5533 Repair Stand Bracket and 1U-5750 Engine Repair Stand
- Available as a kit or individual parts can be ordered separately

### Reference

Service Manual, for C-9 Engines

Media Number	Description
NEEG2925 (Not Shown)	Decal

Item	Part Number	Description
1	176-5487	Valve Spring Compressor <sup>1</sup>
2	173-5523	Valve Seat Installer
3	173-5525	Valve Seat Puller
4	173-5524	Driver Valve Guide
5	191-6077	Bracket
6	173-5527	Cylinder Pack Puller Group
7	136-4632	Timing Pin
8	139-7064	Timing Pin Adapter

Item	Part Number	Description
9	173-5528	Piston Ring Compressor
10	143-9731	Turbocharger Wrench, 122 mm (4.8 in) reach throat
11	143-9730	Turbocharger Wrench, 30 mm (1.18 in) reach throat
12	1U-7430	Front Crank Seal Installer
13	196-5469	Foam Insert
14	196-5472	Storage Case
--	196-3165	Tool Kit, C-9 Engine

(Continued)

**196-3165 Tool Kit, C-9 Engine (Continued)**

Model: C-9 Engine  
Warranty: Six Months

<sup>1</sup>Includes 176-5484 Plate Assembly, 176-5486 Plug Assembly, and 187-1852 Holding Clamp

**173-5533 Repair Stand Bracket**

Warranty: Six Months

Part Number	Description
<b>Engine Repair Stand with Adapter Bracket</b>	
173-5533	Engine Stand Bracket
1U-5750	Engine Repair Stand

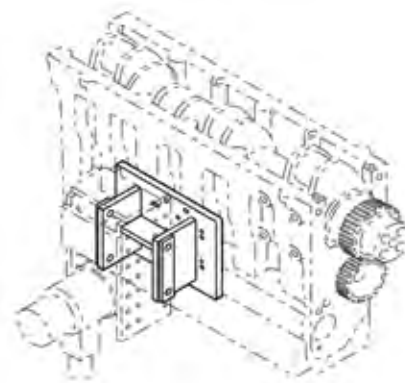

**9U-7530 Tool Kit, 3406E Engine**

Model: 3406E, C-15, C-16  
Warranty: Six Months

- Contains tools to remove and install camshaft and cam bearing, compress valve springs, install valve seals, valve seats, and valve guides, remove and install pendulum damper, adjust injector pre-stroke, remove and install injector sleeve, test and adjust adjustable idler gear, clean injector bores
- Also services cable connectors, and provides necessary electronic cables to test, adjust, and troubleshoot 3406E Engines
- Packaged in 2 plastic containers with foam inserts for ease of handling and storage (Plastic cases and foam inserts are not serviced under Cat® part number; if these items are needed, contact the Dealer Service Tools Division)
- Chart, packaged in each kit, identifies tool requirements by job and lists reference publication form numbers
- Total weight: 48 kg (105 lb)

**Reference**

SENR5580, Service Manual

**NOTE:**

Refer to part number in Tool Guide for individual features/benefits and picture of each tool listed.

Includes	Description
NEEG2581	3406E Tooling Reference Chart

Part Number	Description
9U-7530	Tool Kit, 3406E Engine
<b>Service/Repair Parts</b>	
9U-7256	Guide Assembly
9U-7240	Camshaft Lifting Hook (2 required)
9U-7257	Cradle Assembly
9U-7225	Camshaft Pilot (2 required)
9U-7243	Alignment Sleeve
9U-7210	Puller Plate
9U-7213	Backup Plate
9U-7214	Spacer Plate
9U-7222	Cam Bearing Pilot
9U-7223	Alignment Bushing
9U-7241	Valve Spring Compressor Group

Part Number	Description
<b>Service/Repair Parts (Continued)</b>	
9U-7226	Valve Seal Installer Group
9U-6898	Valve Seat Driver (Exhaust)
9U-6897	Valve Seat Driver (Inlet)
9U-6895	Valve Seat Driver
9U-6894	Guide Collar
9U-6896	Guide Bolt
9U-7227	Injector Height Gauge Assembly
9U-6891	Injector Tool Group
9U-7255	Adjustable Idler Assembly
9U-7324	Indicator Bracket
9U-6862	Small Tapered Brush
9U-6863	Small Bore Brush

(Continued)

## 9U-7530 Tool Kit, 3406E Engine (Continued)

Model: 3406E, C-15, C-16

Warranty: Six Months

Part Number	Description
<b>Service/Repair Parts (Continued)</b>	
9U-7244	End Brush
9U-7237	Drill Extension
4C-5552	Large Bore Brush
7X-1715	Adapter Cable Assembly

Part Number	Description
<b>Service/Repair Parts (Continued)</b>	
7X-1403	Adapter Cable Assembly
7X-1686	Adapter Cable Assembly
7X-1695	Timing Probe Cable
175-3700	Connector Service Kit (less crimp tool)

## 333-0758 Tool Group (Valve Spring Compressor)

### Essential Tool

Model: C175 Engine

Warranty: Six Months

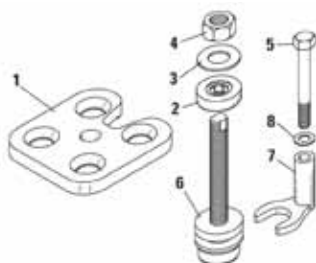

- Used to compress four valve springs to remove valve spring retainer locks
- Allows servicing of valve springs, valve seals, and valves
- Can be used with cylinder head on or off-engine
- Saves time, especially for on-engine applications
- Comes complete with heavy-duty, foam lined carry case (not shown)
- Tool revised to fit Tier I and Tier II cylinder heads

#### References

NEHS0954, Tool Operating Manual, 333-0758 Tool Group (Valve Spring and Injector Sleeve) for C175 Engines

Item	Description	Quantity
1	Base Plate <sup>1</sup>	1
5	Driver (used with Injector Sleeve Puller Installer) <sup>1</sup>	1
6	Spring Compressor Rod Assembly <sup>1</sup>	1
7	Yoke Retainer Assembly <sup>1</sup>	1

<sup>1</sup> Not serviced

Item	Part Number	Description	Quantity
--	333-0758	Tool Group (Valve Spring Compressor)	--
<b>Service/Repair Parts</b>			
2	8S-8287	Thrust Bearing Assembly	1
3	4M-6953	Hardened Washer	1
4	108-2079	Nut	1
8	5P-8245	Hard Washer	1

## 356-8752 G3600 Operator Tool Group

Model Usage: G3606 (3XF), G3608 (4WF), G3612 (1YG), G3616 (4CG)

Warranty: Six Months

- Aids in providing daily service to an engine
- May be used with 169-8373 Bottle Group
- Includes pad of data sheets to record all service information
- Helps to lubricate pivot joints of waste gate, fuel mixing valve, and choke linkage
- Used to remove spark plugs and chase threads
- Helps to clean and gap spark plugs

(Continued)

**356-8752 G3600 Operator Tool Group (Continued)**

Model Usage: G3606 (3XF), G3608 (4WF), G3612 (1YG), G3616 (4CG)

Warranty: Six Months

- Aids in gathering oil samples

Media Number	Description
NEHS0680	Data Sheet Pad

Part Number	Description
356-8752	Operator Tool Group
<b>356-8752 G3600 Operator Tool Group</b>	
1U-9824	Tool Group
245-5829	Coolant Test Kit
4C-4601	Spark Plug Socket
6V-9124	Screwdriver
7X-3387	S·O·S Sampling Valve
8C-3445	Dust Cap (Engine)
8F-9866	Cat® Pro "L" Grease Gun <sup>1</sup>
9U-7511	Spark Plug Seat Cleaner
9U-7516	Spark Plug Gauge

<sup>1</sup>Warranty: Six Months

**360-9664 Diesel Particulate Filter (DPF) Crack Detection Kit**

Model Usage: C13: S/N LEE1-UP, C15: S/N SDP1-UP, B5R1-UP

Warranty: Six Months

- For On-Highway Truck Engines equipped with DPFs (2007 and newer), not for Tier 4 machines
- Used to determine whether a DPF is defective
- Utilized while DPF is still on the engine to take an exhaust sample
- Uses filter paper elements to determine amount of soot leaking through DPF

**Reference**

REHS5017, Special Instructions



<b>360-9664 DPF Crack Detection Kit</b>	
Part Number	Description
360-9664	Diesel Particulate Filter (DPF) Crack Detection Kit
<b>360-9664 DPF Crack Detection Kit</b>	
001-6449	Connector - Flared
360-9665	Box - Filter
360-9666	Orifice - Short
360-9667	Orifice Assembly - Long
360-9668	Cap
360-9669	Foam Assembly
360-9670	Card Comparator
3L-7055	Connector - Pipe

## 399-7930 Crack Detection Group Cap

Model Usage: C7, C9

Warranty: Six Months



- Used with 360-9664 Crack Detection Group to measure leakage of soot through DPF Systems
- Provides proper fitting flanges to restrict exhaust flow during crack detection test
- Fits 4 inch exhaust systems

Serviceable Parts	
Part Number	Description
399-7930	Crack Detection Group Cap
Serviceable Parts	
399-7932	Cap
399-7933	Orifice
399-7934	Plate

## 370-2284 Dummy Injector Tool

Model Usage: 3500 Engines

Warranty: Six Months



- Installs in place of fuel injector and has 1/4" - 18 NPTF tapped port to allow for leak checking of cylinder head

Specifications	
Port Size	1/4" - 18" NPTF
Material	Steel
Seal Installer Dimensions	62mm (2.44in) dia x 147mm (5.79in) long
Weight	1.56kg (3.4 lbs)

Part Number	Description
370-2284	Dummy Injector Tool

## 195-0875 Marine Tool Kit (Not Serviced)

Model: 3116, 3126, 3126B, 3176, 3196 Marine Engines with Metric Fasteners

Warranty: Six Months



- Used for basic engine repairs and maintenance (provides a ride-along tool kit with specific engine tools)
- 195-0875 Tool Kit is not serviced as a group (allows for option of adding or deleting tools to fit the customers needs)
- 202-8643 Tool Box is a plastic, water-tight container (will not rust or scratch like metal boxes)
- Inch sockets and wrenches may be substituted or added to the kit
- Tool box capacity: 9 kg (20 lb)
- Tool box decal: NEEG2916

Included in Kit:
Wrench Group, Metric
Orange Hand Cleaner, 225 mL (7.5 oz)

(Continued)



**195-0875 Marine Tool Kit (Not Serviced) (Continued)**

Model: 3116, 3126, 3126B, 3176, 3196 Marine Engines with Metric Fasteners

Warranty: Six Months

Part Number	Description
195-0875	Marine Tool Kit (Not Serviced)
<b>Recommended Tool List</b>	
1S-0257	Ball Peen Hammer, 0.34 kg (12 oz)
1U-9579	WypAll Paper Wipers (bundle)
285-1145	Combination Padlock
5F-4764	Rolling Head Pry Bar, 40.64 cm (16 in) <sup>1</sup>
6V-6193	Diagonal Cutting Pliers, 44.45 cm (17 1/2 in)
8H-8575	Extension Assembly
8H-8576	Adapter

Part Number	Description
<b>Recommended Tool List (Continued)</b>	
239-6824	Reversible Ratchet, 3/8 in Drive
9U-7290	Screwdriver Set
141-1655	Inspection Light
146-2728	Flex Pickup Tool
185-3630	Filter Strap Wrench Assm. <sup>1</sup>
194-3574	3/8 Drive, 12 Point Metric Socket Set, 12-piece
202-8643	Tool Box (plastic)

<sup>1</sup>Warranty: Six Months

**372-5257 EGR Leak Detection Kit**

Model Usage: CT660 Truck, CT11, CT13, CT15

Warranty: Manufacturer's

- Used to perform leak test on each chamber of the EGR cooler
- Uses compressed air pressure to detect leaks
- Test can be performed in less than 5 minutes
- Kit includes 10 components including a regulator assembly for more accurate test results

Specifications	
Dimensions	495.3 x 393.7 x 165.1 mm (19.5 x 15.5 x 6.5 in)
Weight	7.3 kg (16.0 lb)

Part Number	Description
372-5257	EGR Leak Detection Kit



**373-4725 Seal Installer**

Model Usage: CT660 Truck, CT11, CT13

Warranty: Manufacturer's

- Used to install the crankshaft front oil seal on the 11L and 13L engines

Specifications	
Dimensions	203.2 x 203.2 mm (8.0 x 8.0 in)
Weight	5.0 kg (11.0 lb)

Part Number	Description
373-4725	Front Oil Seal Installer

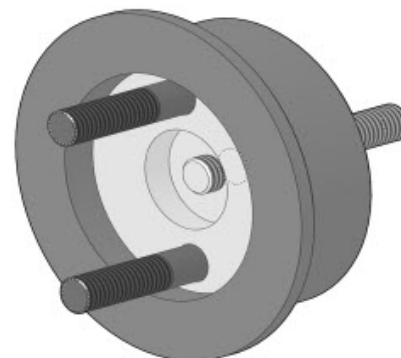

## 373-4726 Seal Installer

Model Usage: CT660 Truck, CT11, CT13

Warranty: Manufacturer's

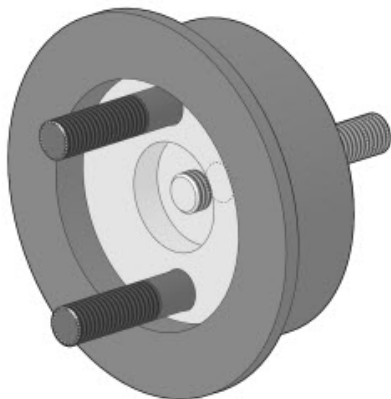

- Used to install the crankshaft rear oil seal on the 11L and 13L engines

Specifications	
Dimensions	182.9 x 177.8 mm (7.2 x 7.0 in)
Weight	4.5 kg (9.9 lb)

Part Number	Description
373-4726	Rear Oil Seal Installer

## 373-4732 Air Intake Guard

Model Usage: CT660 Truck

Warranty: Manufacturer's

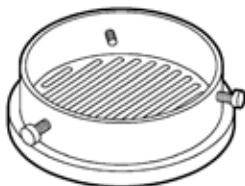

- Used to help prevent foreign material from entering the air intake port

Specifications	
Dimensions	7 in. diameter x 2 in height
Material	Plastic

Part Number	Description
373-4732	Air Intake Guard

## 373-4733 Pilot Bearing Seal Installation Tool

Model Usage: CT660 Truck

Warranty: Manufacturer's

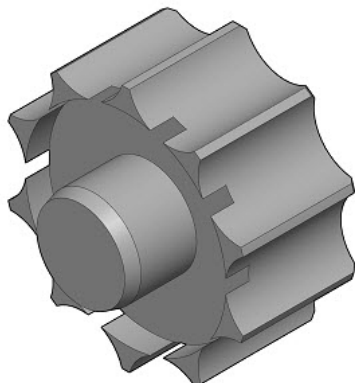

- Used to press the pilot bearing seal into the flywheel housing on 11L and 13L engines

Specifications	
Dimensions	172.7 x 132.1 x 121.9 mm (6.8 x 5.2 x 4.8 in)
Weight	0.63 kg (1.4 lb)

Part Number	Description
373-4733	Pilot Bearing Seal Installation Tool

### 373-4796 High Pressure Pump Drive Holding Plate

Model Usage: CT660 Truck, CT11, CT13

Warranty: Manufacturer's

- Holding fixture used for high pressure pump
- Mounts in a vise for installation of pump drive gear

Specifications	
Dimensions	261.6 x 170.2 x 175.3 mm (10.3 x 6.7 x 6.9 in)
Weight	2.53 kg (5.57 lb)

Part No.	Description
373-4796	High Pressure Pump Drive Holding Plate

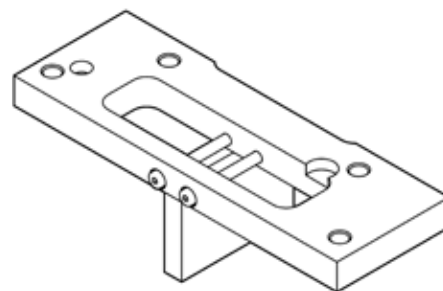

### 373-4797 High Pressure Pump Drive Seal Installer

Model Usage: CT660 Truck, CT11, CT13

Warranty: Manufacturer's

- Used to install high pressure pump drive seal

Specifications	
Dimensions	119.4 x 111.8 x 61.0 mm (4.7 x 4.4 x 2.4 in)
Weight	0.61 kg (1.35 lb)

Part No.	Description
373-4797	High Pressure Pump Drive Seal Installer

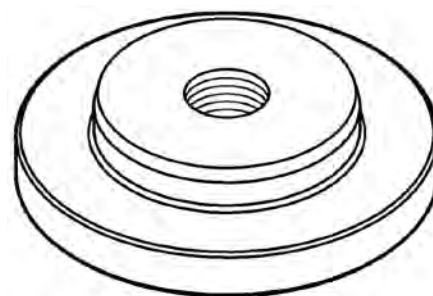

### 373-4798 EGR Coolant Housing Upper Elbow Extension Tube Seal Installer (large)

Model Usage: CT660 Truck, CT11, CT13

Warranty: Manufacturer's

- Used to install the large extension tube seal into the upper EGR coolant housing

Specifications	
Dimensions	119.4 x 111.8 x 61.0 mm (4.7 x 4.4 x 2.4 in)
Weight	0.45 kg (1.0 lb)

Part Number	Description
373-4798	EGR Coolant Housing Upper Elbow Extension Tube Seal Installer (large)

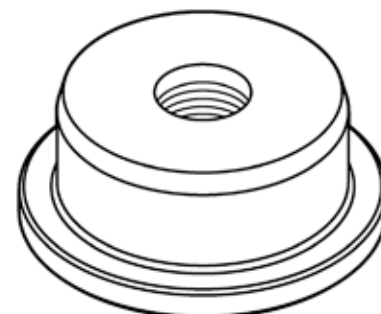

## 373-4799 EGR Coolant Housing Upper Elbow Extension Tube Seal Installer (small)

Model Usage: CT660 Truck, CT11, CT13

Warranty: Manufacturer's

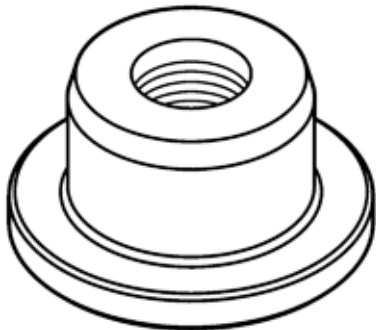

- Used to install the small extension tube seal into the upper EGR coolant housing

Specifications	
Dimensions	25.4 x 25.4 x 25.4 mm (1 x 1 x 1 in)
Weight	0.45 kg (1.0 lb)

Part Number	Description
373-4799	EGR Coolant Housing Upper Elbow Extension Tube Seal Installer (small)

## 374-6394 Sleeve Protrusion Hold Down Clamps

Model Usage: CT660 Truck, CT11, CT13

Warranty: Manufacturer's



- Used to secure cylinder liner in place to accurately measure line protrusion during service
- Clamps are secured in place with four 10.9 grade bolts

Specifications	
Dimensions	101.6 x 88.9 x 33.0 mm (4.0 x 3.5 x 1.3 in)
Weight	1.16 kg (2.85 lb)

Part Number	Description
374-6394	Sleeve Protrusion Hold Down Clamps

## 374-6417 Fey Ring Installation Tool

Model Usage: CT660 Truck

Warranty: Manufacturer's



- Used to align and install fey rings on the exhaust manifold
- Cone positioned on manifold housing as guide to properly seat rings
- Plastic installer used to expand rings over cone to properly seat the fey rings

Specifications	
Dimensions	127.0 x 121.9 x 7.4 mm (5.0 x 4.8 x 2.9 in)
Weight	0.9 kg (1.3 lb)

Part Number	Description
374-6417	Fey Ring Installation Tool

### 376-7698 Crankcase Pressure Test Adapter

Model Usage: CT660 Truck, CT11, CT13

Warranty: Manufacturer's

- Used to measure combustion gas flow out of the engine breather
- Can be used with the digital manometer from the 368-8645 Blow-by Group or the 8T-0452 Water Manometer

Specifications	
Dimensions	2.7 x 8.3 x 1.7 in
Weight	1.2 lbs

Part Number	Description
376-7698	Crankcase Pressure Test Adapter

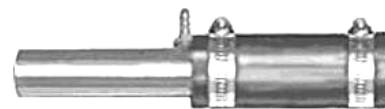

### 384-2804 G3500 Valve Seat and Guide Runout Tool

Model Usage: G3512C, G3512E, G3516C, G3516E, G3520, G3520C and G3520E

Warranty: Manufacturer's

- Used to measure valve guide to valve seat runout
- Checks accuracy of total valve seat runout

#### Reference

SEBF9137-05, Reuse and Salvage Guidelines

NEHS1140 Tool Operating Manual

Part Number	Description
384-2804	G3500 Valve Seat and Guide Runout Tool
<b>384-2804 Gauge Group Service/Repair</b>	
384-2802	Pilot



### 399-2786 Compression Test Adapter

Model Usage: All C3.8 Engines

Six Months

- Used to easily check cylinder compression on the C3.8 engine
- Used with the 9U-6274 Compression Test Group

Part Number	Description	Dimensions
399-2786	Compression Test Adapter	170.2 x 38.1 mm (6.7 x 1.5 in)



## Fuel System Test Tools

### FT2642 Nozzle Block to Filter Block Tubing

### FT2643 Filter Block to Metering Unit Tubing

Model: AVM 12C Fuel Injection Test Bench

Warranty: None

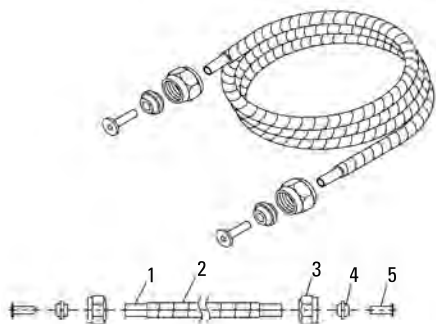

- Provides more durable outer tubing wrap for early test benches
- Used with discontinued 132-9753 AVM 20-12C Fuel Injection Test Bench, discontinued 139-1437 AVM 20-12C Fuel Injection Test Bench, Bench S/N 0001/0023
- Tubing must be cut to identical lengths for metering accuracy
- Both FT2642 and FT2643 can be made from either 9U-7707 [310 cm (122 in)] long or 9U-7702 [3353 cm (110 ft)] long

Part Number	Tubing Length	Spirowrap Length (Installed)	Spirowrap Free Length
FT2642	305 mm (12.0 in)	280 mm (11.0 in)	440 mm (17.3 in)
FT2643	270 mm (10.6 in)	245 mm (9.6 in)	360 mm (14.2 in)

Item	Description		
1	Flexible Tubing (1 1/4 in TFE-White)		
3	Nut (use existing)		

Item	Part Number	Description
2	5P-6039	Spirowrap, 6 mm (0.24 in)
4	9U-7704	Ferrule, 6.35 mm (0.25 in)
5	7K-8332	Insert

### FT2620 Access Cover, AVM

Model: Hartridge AVM 20-12C Fuel Injection Test Bench (Serial Number 1 thru 18)

Warranty: None

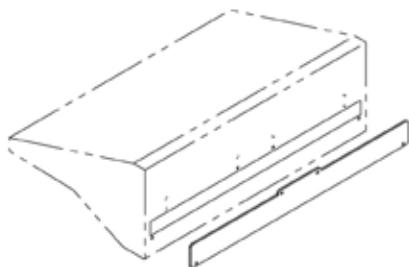

- Drawing provides dimensions to cut access hole and fabricate cover for tip shield access

## 158-2262 AVM 2-PC Fuel Injection Equipment Test Stand

Model: Cat® Engines

Warranty: Manufacturer's One Year

European Union compliant, CE marked

Test benches are capable of operating in the 380-480 Volt range but actual voltage will be checked and or changed during the on-site commissioning by the authorized Hartridge agent.

- Used to test fuel injection system components for pump and line fuel systems on Cat® engines

### Machine Basics

- Advanced Video Metering (AVM)
- Designed to Caterpillar® specifications to test most injection pumps in the Cat® product line (includes all Cat-built pumps, Stanadyne DB2 and DB4 pumps used on 3054 and 3056 pre-emission certified engines, and Zexel and Nippondenso pumps used on 3046, 3064, and 3066)
- Stanadyne, Lucas, and Bosch emission certified pumps may not be serviced by Cat® dealers
- Complies with European CE marking directive and conforms with ECM standards
- Basic machine and metering unit complies with ISO4008, EEC, and UL/CSA standards (pump mounting system, cooled nozzle block, and master nozzles are unique to Cat®)
- "DCdrive" and standard PC architecture allow modem or network connections
- Uses industry standard PC allowing future expansion
- Uses a direct drive, high-torque, 15 kW (20 Hp) DC motor for low RPM performance
- An on-board air supply with electronic readout is available for setting FARC controls
- Electronic dynamic phasing
- Auto Step test plan editor and execution
- Pressure phasing to 80 bars
- Other features are 2 variable DC supplies, cooled metering unit, back leakage temperature measurement at pump outlet, analog speed trim for fine control of governors, digital pressure displays, drive "nudge" control
- This unit has many common parts currently used with standard Hartridge benches, resulting in product support from Delphi Diesel Systems Worldwide

### Machine Displays

- Control panel pivots to permit operation from either side of test stand
- Display modes include; speed, pump output, phasing angle, pressure and test stand self diagnostic information
- With exception of oil pressure control valves and emergency stop buttons, a built-in computer and keyboard control test stand with user friendly Windows®
- Pump output and test stand operating data are displayed on a 38 cm (15 in) color monitor

### Nozzle Block

- Cooled nozzle block dissipates heat, at its source, from high-energy Cat® fuel pumps
- Articulated support arm pivots beneath front of table, allowing master nozzle mount to be repositioned without disturbing pump mounting brackets
- Underslung multi-position master nozzle mount has vertical adjustment

### Injection Pump Mounting Information

- Standard Cat® pump mounting rail uses existing mounting accessories and hardware (not included)

### Testing

- "Intelligent Firing Order Learning" allows pump to be connected to test injectors in most convenient way
- Drive system automatically compensates for load variations (provides a constant, pre-selectable test speed within a range of 30 to 4000 RPM)
- All connections and associated valves are grouped together on the bulkhead, leaving a large unobstructed, self-draining work area at front of table for tools and fittings
- Powerful Hewlett-Packard computer controlled platform is flexible, and upgradeable to meet future requirements and provides accurate metering and information management/documentation capabilities provide compliance with current emissions and ISO standards



(Continued)

## 158-2262 AVM 2-PC Fuel Injection Equipment Test Stand (Continued)

Model: Cat® Engines

Warranty: Manufacturer's One Year

- High-speed, 12-cylinder advanced metering system reduces test time

### Operation

- Control console pivots to permit operation from either side of test stand
- Keyboard height and angle are set to minimize strain
- Floppy and CD-ROM can be accessed from front of machine
- Computer and keyboard allow operator to enter data (speed) and observe results (pump output) on display
- All functions are menu controlled
- On-screen "analog" pressure gauges, a first in the test bench market, allows viewing trends and relative measurements while displaying numerical value for accurate setting
- Dynamic phasing display shows all pump phasing angles ( $\pm 0.1^\circ$ ) simultaneously for rapid adjustment
- Self-diagnostic function will indicate motor over/temperature, air supply failure, dirty filter, stalled motor, and low tank levels
- Built-in PC allows test data to be stored on standard database software or print to color printer (not included). Operating data such as test plans can be entered, stored, removed and executed

### Service

- Built-in, self-diagnostic routines are used to detect internal machine problems, with faults and test results displayed on LCD screen
- All electronic circuits use solid state technology and feature simple plug-in replacement boards
- All test oil supply and lube system components are located on left-hand side of bench
- All electrical and electronic services are on right side of bench

## Worldwide Compatibility

- Machines have multiple language capability (current language choices are Dutch, English, French, German, Greek, Italian, Portuguese, Spanish, and Turkish)
- The machines include the Manual on CD-ROM in the following languages: Dutch, English, French, German, Greek, Italian, Portuguese, Spanish, and Turkish
- Bench is CSA-approved
- Bench meets applicable CE directives when on-site commissioning is completed

## Repair Information

If test stand needs more than general maintenance or adjusting, contact original equipment manufacturer at the following locations.

Hartridge Limited

The Hartridge Building

Network 421

Radclive Road

Buckingham

MK18 4FD

U.K.

Switchboard: 44 (0) 1280 825 600

Fax: 44 (0) 1280 825 601

Service 24-Hour: 44 (0) 1280 825 650

Service Fax: 44 (0) 1280 825 675

Service E-mail address: support@hartridge.com

Web site: www.hartridge.com

## Reference

NEHS0724, Tool Operating Manual (included with bench — may be ordered separately)

## Ordering Information

- Test benches are capable of operating in the 380-480 Volt range, but actual voltage will be checked and or changed during the on-site commissioning by the authorized Hartridge agent. On-site startup is provided by the manufacturer. For 220 to 240 volt applications, a transformer is required.

(Continued)



Worldwide Compatibility (Continued)

Part Number	Description
158-2262	AVM 2-PC Fuel Injection Equipment Test Stand, 380 to 480 volt, 50/60 Hz, 3-phase

Installation Requirements

These items are necessary for installation and must be ordered separately.

- 6V-6067 Calibration Fluid (208.5 L [55 gal]) or 6V-6068 Calibration Fluid (19 L [5 gal])
- 10W Engine lube oil preferred; 10W30 is acceptable
- 380 to 480 volt, 50/60 Hz, 3-phase (45 amp maximum)
- 3 lpm (0.6 gpm) at 20° C (68° F) maximum temperature at 1.5 bar pressure

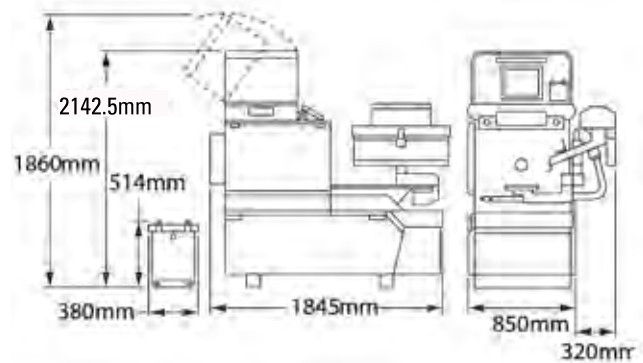

Engine Tools

On-Site Startup and Commissioning

A one-time on-site commissioning and basic bench training is included in the price of the bench. This service is provided by Hartridge.

- Fuel injection pump mounting and drive hardware must be ordered separately (contact your Dealer Service Tools Division representative for ordering assistance)

Specifications

Case size	191 x 114 x 209 cm (75 x 45 x 81 in)
Gross weight	1170 kg (2580 lb)
Net weight	970 kg (2140 lb)
DC motor	14.9 kW (20 Hp) high torque
Flywheel	1.8 kgm <sup>2</sup> (43 ft-lb <sup>2</sup> )
Motor RPM	30 - 4000 RPM load compensating
Electrical supply	For 20 Hp: 380 - 480 V, 3-phase (80 A max.)
Current amp requirements	63 A, but 100 A service is recommended
Transformer requirements	208 - 240 V (45 kva) units require a 50 - 60 Hz
Compressed air supply	6 bar (90 psi)
Water supply	3.0 lpm (0.06 gpm)

## Computer Drive System

Engine Tools

Computer:	
PC	Routeco
Processor	Pentium P633
Hard disk drive	10 GB
RAM	64 MB
Operating system	NT Workstation
Floppy disk drive	3.5 in 1.44 MB
CD-ROM drive	
Mouse	(PS/2 connection)
Serial ports	2
Parallel port	1
Expansion	Standard ISA or PCI card interface
Industrial grade monitor	38 cm (15 in) diagonal color 800 x 600 SVGA
Keyboard	102 key with protection membrane cover
Drive System:	
Motor	DC Thyristor controlled, 15 kW (20 Hp)
Speed range	30 - 4000 RPM
Speed/torque (RPM/N·m)	0/165, 590/165, 1500/95, 2500/51

## Continuous Operation Torque Ratings Speed Control

Speed Control:	
Closed loop speed control system	Zero steady state droop
Digital speed selection	From computer application
Analogue trim adjustment	±10%
Acceleration rate	400 RPM per second
"Nudge" function	Orientates drive to aid pump mounting
Flywheel inertia	1.8 kgm <sup>2</sup> (43 ft-lb <sup>2</sup> )
Flywheel brake	Air-operated friction brake for emergency stop

## Continuous Operation Torque Ratings Calibration System

Calibration System:	
Video display metering	12 line
Color display screen	38 cm (15 in)
Capacity	5 - 500 mm <sup>3</sup> , stroke with 3 measuring modes, calibrate, over-check, and average
Selectable units	(mm <sup>3</sup> /st, cc/50, cc/100, cc/125, cc/250, cc/300, cc/500) and adjustable scale via upper/lower limits entry
Back leakage flowmeter display	50 - 1500 cc/min or 3 - 90 L/hr
Units	cc/min, l/hr, and cc/1000st

**Instrumentation**

Instrumentation						
	On-screen display	Resolution	Stability	Range	Display	Units
Tachometer	Numerical	1 RPM	±1 RPM			
Fuel Supply				1 - 4 bars	On-screen as numerical value and analogue representation	bar, Mpa, psi, mmHg, mbar, hPa, kPa
Auxiliary A				0 - 4 bars	On-screen as numerical value and analogue representation	bar, Mpa, psi, mmHg, mbar, hPa, kPa
Auxiliary B				0 - 16 bars	On-screen as numerical value and analogue representation	bar, Mpa, psi, mmHg, mbar, hPa, kPa
Boost Pressure				0 - 4 bars	On-screen as numerical value and analogue representation	bar, Mpa, psi, mmHg, mbar, hPa, kPa
Pressure Phasing	80 bar displayed as numerical value					bar, Mpa, psi, mmHg, mbar, hPa, kPa
Lube Oil	7 bar displayed as numerical value					bar, Mpa, psi, mmHg, mbar, hPa, kPa
Advance (optional)		0.1 mm		±10 mm		mm, DPA°, DPC°, Stanadyne°, Bosch°
Fuel Supply Temperature				0° to 80° C	Numerical value on-screen	° C (° F)
Back Leakage	Both temperature and flow numerical values			0° to 80° C (0° to 175° F)		Flow units: cc/min, l/hr, and cc/1000str

**Phasing**

Phasing		
Pressure phasing	Standard, dynamic phasing optional, and angle of rotation shown	
Resolution display	0.1°	
	Range	Resolution
Static Phasing	0° to 360°	0.1°
12-line Dynamic Phasing	0° to 360°	0.1°

## Hydraulic System

Engine Tools

Test Oil Supply and Controls	
Electric motor	Direct pump drive
Pressure rating	550 L/hr and 0 - 4 bar (0 - 60 psi)
Pressure phase supply	0 - 80 bar
Tank	45 L (10 gal) capacity
Temperature Control	
Temperature controlling	±2° C
Lube Oil Supply	
Pressure	250 L/hr and 0 - 4 bar
Tank	14 L (3 gal) capacity
Separate hours counters for:	
Fuel pump	
Fuel filter with "change filter" message every 500 hours	
Drive	
Machine	

## Auxiliaries

Two DC supply outlets	0 - 25 V at 3 A, which can be parallel connected to give 6 A
Multi-pin 110V connector	For external single cylinder calibrator and point of injection transducers
Clock display	Real time
Socket	For advance kit transducer

## 6V-7900, 208/240 V; 1U-8212, 440/480 V; 1U-8213, 380/420 V Test Stands (All Discontinued)

### Repair Information



If test stand needs more than general maintenance or adjusting, contact original equipment manufacturer at the following locations.

Hartridge Limited  
 The Hartridge Building  
 Network 421  
 Radclive Road  
 Buckingham  
 MK18 4FD  
 U.K.

Switchboard: 44 (0) 1280 825 600  
 Fax: 44 (0) 1280 825 601  
 Service 24-Hour: 44 (0) 1280 825 650  
 Service Fax: 44 (0) 1280 825 675  
 Service E-mail address: support@hartridge.com  
 Web site: www.hartridge.com

Part Number	Description
6V-7900	Test Stand, 208/240 V
4C-8212	Test Stand, 440/480 V
1U-8213	Test Stand, 380/420 V

### FIETS Nozzle Block and Lines

Model: Fuel Injection Equipment Test Stand  
 Warranty: Six Months

Nozzle block and replacement lines are applicable to all Fuel Injection Equipment Test Stands (discontinued 6V-7900, discontinued 6V-7901, discontinued 6V-7902, discontinued 6V-7903, discontinued 6V-9440, discontinued 1U-8212, discontinued 1U-8213)

#### Cooled Nozzle Block

- Nozzle holding block uses test oil from phasing pressure circuit to carry nozzle-generated heat back to sump where it is removed by heat exchanger
- Improves work environment by eliminating hot test oil vapors at graduates
- Reduces heat-related deterioration of test stands non-metallic lines
- Contains replaceable nozzle tip shields to prevent erosion of nozzle block
- Required when using latest test specifications (in TMI)
- Required when testing pumps from higher horsepower 3400 Servies Engines

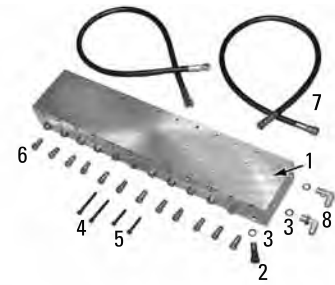

#### FIETS Lines Group

- Contains the following groups:
  - 9U-7694 Nozzle Group Lines
  - 9U-7697 Discharge Conduit Group
  - 9U-7697 Discharge Conduit Group — bypasses constricting joints in swing arm
  - 9U-7694 Nozzle Lines Group — provides nozzle bleed return to test oil sump
- Increases test stand accuracy by minimizing leaks
- Former nylon tubing replaced with teflon tubing for better abrasion resistance of tubes inside swing arm and longer life
- Flexible tubing is fuel, heat, and ozone resistant (used for pulse dampers and lines to graduates)
- Internal routing of teflon lines redirected through front bearing support arm — reduces kinking and makes line replacement faster and easier
- Corrects possible contamination of test oil from table drain tray on certain vintage benches

#### References

NEHS0594-01, Using the TMI System to Retrieve Off Engine Injection Pump Test Specifications for the FIETS  
 NEHS0593, Tool Operating Manual, Installing the Replacement Lines on the FIETS

Cooled Nozzle Block Parts			
Item	Part Number	Description	Quantity
1	128-5093	Block Nozzle	1
2	128-5094	Tip Shield Fitting	12
3	3J-1907	O-ring Seal for 5P-9617 Adapter	14
4	6L-5551	Bolt	2
5	2H-3764	Bolt	2
6	5P-4400	Air Block Connector	12
7	7G-7105	Hose Assembly	2
8	030-7947	Elbow Fitting	2

# Fuel System Test Tools

## 9U-7697 Discharge Conduit Group

Warranty: Six Months

Engine Tools

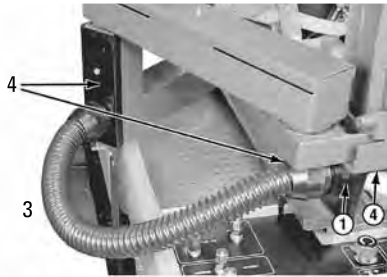

Item	Part Number	Description
--	9U-7697	Discharge Conduit Group
<b>Discharge Conduit Group Consists of:</b>		
1	9U-7457	Conduit Bracket
2	9U-7458	Conduit Fitting
3	9U-7459	Flexible Conduit
4	9U-7701	Arm Lining Tube
Not shown	8D-7712	Head Screw

## 9U-7694 Nozzle Lines Group

Warranty: Six Months



Item	Part Number	Description
--	9U-7694	Nozzle Lines Group
<b>Nozzle Lines Group Consists of:</b>		
1	5R-7136	Sealing Washer
2	9U-7698	Tee Fitting
3	9U-7699	Flexible Tubing
4	9U-7707	Flexible Tubing
5	9U-7706	Hose Clamp
6	068-9941	Wire Tie
Not shown	1S-9593	Cable Strap

## Calibration Fluid

Warranty: None



- Fuel injection test benches
- Pop Testers

Part Number	EAME Part Number	Qty.	Size
6V-6068	185-4665	1	18.9 L (5 gal)
6V-6067	N/A	1	208 L (55 gal)

## Fuel Injection Tube Assemblies

Model: Cat® Fuel Injection Test Bench (FITB) and Fuel Injection Equipment Test Stand (FIETS)

Warranty: Six Months



- Bend-to-fit lines that reduce need for special fuel injection lines
- Data available in TMI uses 9U-6705 Master Nozzles and 9U-5298 and 9U-5299 lines (see SEHS0594)

### Referenes

NEHS0594, Tool Operating Manual, Using TMI to Find Pump Specifications  
LEBQ0724, Technical Marketing Information (TMI)

(Continued)

### Fuel Injection Tube Assemblies (Continued)

Model: Cat® Fuel Injection Test Bench (FITB) and Fuel Injection Equipment Test Stand (FIETS)  
 Warranty: Six Months

Part Number	Overall Length	Use
9U-5298	76 cm (30 in)	Used for testing all in-line pumps and 3208
9U-5299	127 cm (50 in)	Used for testing all 3400 Vee pumps

### 9U-6705 Master Nozzle Group

Model: Cat® Fuel Injection Test Bench (FITB) and Fuel Injection Equipment Test Stand (FIETS), AVM  
 Warranty: Six Months

Part Number	Description
9U-6705	Nozzle Master
Service/Repair Parts	
9U-5037	Bleed Fitting
7W-4486	Sealing Washer

- Replaces discontinued 1U-5500 Master Valve Assembly, 9U-5024 Master Valve Assembly, and 6V-9470 Master Valve Assembly
- Used to test fuel pump delivery rates on FITB and FIETS
- Has improved accuracy of  $\pm 1\%$  with four-orifice tip (greatly improved over former valve assemblies with  $\pm 5\%$  accuracy)
- Required when using new pump performance test specifications available in TMI
- Use with 9U-5298 and 9U-5299 Tube Assemblies (high pressure fuel lines)



#### References

NEHS0594, Tool Operating Manual, Using TMI to Find Off-Engine Test Specs  
 LEBQ0724, Technical Marketing Information (TMI)

### Storage Bags

Warranty: None

- Keep fuel lines sealed and protected from dust and dirt
- Ziplock closure prevents oil and other greases from leakage
- Printed with 2-color Cat® logo, black part number, and a white area that can be written on to identify the parts inside the bag
- Transparent so the parts can be visibly identified
- May be used for a variety of purposes
- 3 sealed hang holes on top of bag spaced to fit standard one inch pegboard hooks

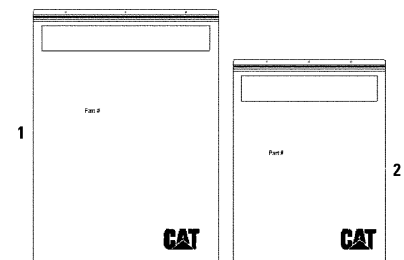

Item	Part Number	Outside Dimensions	Ziplock Closure	Clear Vinyl Back and Front
1	152-0789	55.9 x 76.2 mm (22 x 30 in)	Top of bag (55.9 mm [22 in])	10.0 mm
2	152-0788	45.7 x 60.0 mm (18 x 24 in)	Top of bag (45.7 mm [18 in])	10.0 mm

## NEHS0594 Using TMI for Finding Injection Pump Off Engine Test Specifications

Model: Fuel Injection Equipment Test Stand

Warranty: None

- Contains complete instructions to obtain test specifications through TMI on Caterpillar® Network
- New data format gives larger selection of data for each pump (does not require resetting pump)
- Data can be obtained using injection pump and governor group part number, or engine arrangement number
- Most current data is always available on line

### Reference

LEBQ0724, TMI Technical Marketing Information

## Calibration Fluid

Model: Cat® Fuel Injection Test Bench and Cat® Fuel Injection Equipment Test Stand

Warranty: Six Months

- SAE J967 (ISO 4113) Calibration Fluid recommended by Cat® for use in fuel injection test benches, 5P-4150 Nozzle Tester Group and discontinued 6V-4022 Injector Tester

Part Number	Size
6V-6067	208 L (55 US gal)
6V-6068	18.9 L (5 US gal)

## Pressure Gauges

Model: All Models with Pump and Line Fuel Systems

Warranty: Six Months

Typical Pressure Gauge



- Used to replace original gauges on the discontinued 6V-7900, discontinued 1U-8212, and discontinued 1U-8213 Fuel Injection Test Benches, and discontinued 132-9753 and discontinued 139-1437 (AVM)
- Replaces without modifying test stand
- Displays both kPa and psi
- Diameter: 102 mm (4.0 in)
- 1/4 inch NPT lower back connection
- Liquid-filled, chrome-plated cast brass case
- Clamp and profile ring included for panel mounting

Part Number	Replaces Hartridge Gauge
4C-4617	0 to 7000 kPa (0 to 1000 psi)
9U-6099	-100 to 4000 kPa (-14 to 580 psi)
9U-6100	0 to 700 kPa (0 to 101 psi)
8T-7637	0 to 1400 kPa (0 to 203 psi)



**9U-7840 Calibration Fluid and Diesel Fuel Test Kit**

Model: FIETS, FITB, AVM, All Cat® Engines

Warranty: Six Months

- Used to measure viscosity and specific gravity of SAE J967D (ISO4113) calibration fluid
- Used with fuel injection equipment test stand (FIETS) and fuel injection test bench (FITB) — helps to maintain accuracy of test equipment
- Performs test to make sure calibration fluid in test equipment is within specifications
- Saves money — fluid is not changed prematurely
- Beakers made from durable Nalgene — will not shatter
- Viscosity cup is individually calibrated for each test group — cup and calibration chart marked with individual serial number (matched set)
- Used to correct measured horsepower for density of fuel when testing engines on dynamometers

**References**

NEHS0607, Tool Operating Manual

NEHS0631, Tool Operating Manual, General Maintenance for FIETS

NEHS0640, Tool Operation Manual, Installing Fuel Suction Port on the FIETS

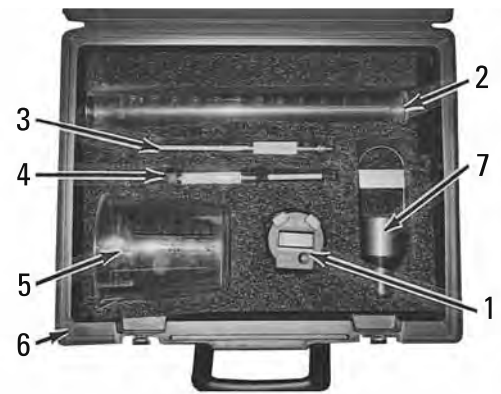

Engine Tools

Case (W x L x D)	33 x 40.5 x 15.3 cm (13.0 x 16.0 x 6.0 in)
Weight	2 kg (5.0 lb)
Viscosity cup	individually serialized (includes calibration sheets)
Beaker material	Nalgene
Also Included (not shown): NEEG2600 Decal	

Item	Part Number	Description
--	9U-7840	Calibration Fluid and Diesel Fuel Test Kit
<b>Service/Repair Parts</b>		
1	9U-7839	Stopwatch
2	1P-7438	Beaker
3	5P-2712	Thermo-Hydrometer, Assembly API Gravity Scale

Item	Part Number	Description
<b>Service/Repair Parts (Continued)</b>		
4	1P-7408	Thermo-Hydrometer, Gravity Scale
5	9U-7842	Beaker
6	4C-3975	Plastic Storage Case
7	9U-7841	Viscosity Cup
Not shown	9U-7917	Button Battery (one required)

## 136-8330 Basic Mounting/Setup Group (Not Serviced)

Model: All Fuel Injection Equipment Test Stands (FITB, FIETS, and AVM)

Warranty: Six Months

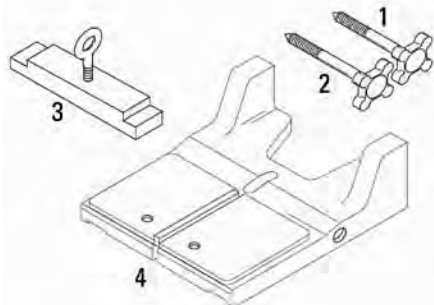

- Replaces discontinued 1U-7426 Pump Adapter Group
- Used to adapt injection pump mounting and drive groups to test stand
- Used with fuel injection equipment test stands (FITB, FIETS, and AVM)
- Group has been updated to eliminate non-current tooling and add new required tooling
- Tooling is required for off-engine testing of injection pumps and governors
- Parts are serviced separately to reduce dealer cost (no need to purchase tools already in inventory)

### References

NEHS0594, TMI Specification  
 NEHS0607, 9U-7840 Calibration Fluid Test Kit  
 NEHS0624, 4C-8192 Heavy Duty Coupling Group (Hartridge Bench UpGrade)  
 NEHS0625, Tool Operating Manual, 3408/12, PEEC NSFS  
 NEHS0631, FIETS General Maintenance and Trouble Shooting  
 NEHS0639, Tool Operating Manual, 3406B and 3406C, PEEC NSFS  
 NEHS0640, Tool Operating Manual, Calibration Fluid Suction Port  
 SEHS8024, 6V-6070 Governor Adjustment Tool Group  
 SEHS9318, 3161 Woodward Test and Adjustment  
 SMHS7013, 5P-4203 SMFS Tool Group

Item	Part Number	Description	Quantity
--	136-8330	Basic Mounting/Setup Group (not serviced)	--
<b>Mounting Hardware</b>			
1	6V-6103	Screw Assembly	2
2	6V-9134	Screw Assembly	2
3	6V-9138	Clamp Assembly	2
4	6V-9132	Fixture Assembly	1

## Lines and Testing Hardware

Warranty: Six Months

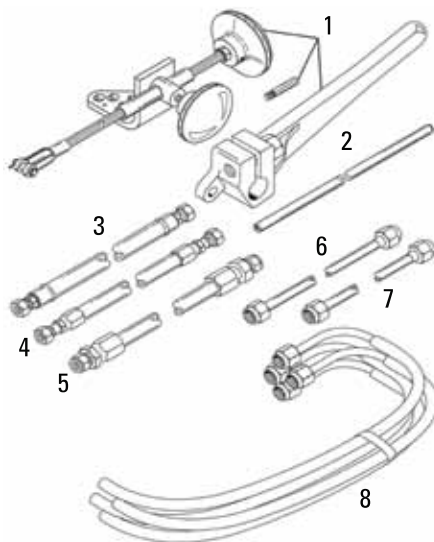

Item	Part Number	Description	Quantity
<b>Lines and Testing Hardware</b>			
1	1P-3520	Control Group	1
2	126-1827	Rod	1
3	7G-7105	Hose Assembly	3
4	3V-2744	Hose Assembly	1
5	031-2125	Hose Assembly - Hyd	1
6	9U-5299	Tube As - Fuel Injection Test	12
7	9U-5298	Tube As - Fuel Injection Test	8
8	5P-6515	Lines Group	2

## Additional Service/Repair Parts

Warranty: Six Months

Service/Repair Parts (without Part Numbers) for discontinued 1P-3520 Control Group		
Item	Description	Qty.
3	Lug	1
9	Pin	1
13	Stud	1
Additional Service Part		
	Hose Assembly	#6 (37 degree) [9/16 - 18 thd x 965 mm (38.0 in) long]

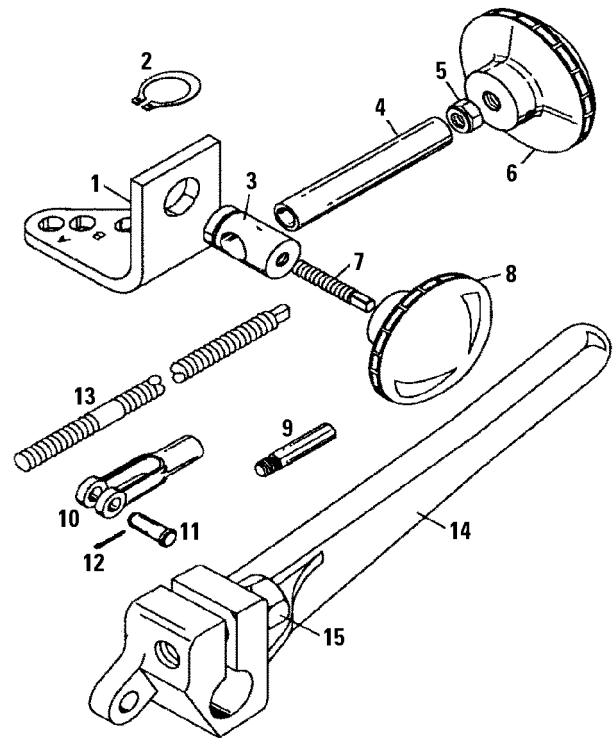

Engine Tools

Item	Part No.	Description	Qty.	Where Used
Service/Repair Parts for discontinued 1P-3520 Control Group				
1	1P-3493	Bracket	1.0	--
2	2J-6356	Ring	1.0	--
3	1P-3487	Lug	1.0	--
4	1P-2335	Sleeve	1.0	--
5	1A-8285	Nut (3)	1.0	--
6 <sup>1</sup>	1P-2333	Knob	2.0	--
7	1P-3492	Stud	1.0	--
9	1P-3486	Pin	1.0	--
10	1P-3494	Yoke	1.0	--
11	1P-3491	Pin	1.0	--
12	3B-4609	Pin	1.0	--
13	1P-3488	Stud	1.0	--
14	6D-4396	Lever	1.0	--
15	1A-2029	Bolt	2.0	--

Item	Part No.	Description	Qty.	Where Used
Additional Hardware (Dependent on Pump Model)				
--	6V-7793	Coupling Group	1.0	drive adapt Hartridge 20.00 mm (0.787 in) jaw
--	1U-5223	Fitting	6.0	bleed return for 1P-1795 (discontinued)
--	3P-1539	Tube Assembly	8.0	1.60 mm (0.063 in) ID x 533.4 mm (21.0 in) long
--	4L-5937	Injection Pump Fuel Line Assembly	6.0	1.60 mm (0.063 in) ID x 431.8 mm (17.0 in) long
Additional Parts				
6	6V-9138	Clamp Assembly	--	fixture assembly to rail system
9	6V-9134	Screw Assembly	--	fixture assembly to bench rails (short)
10	6V-9132	Fixture Assembly	--	target/fixture assembly to bench rails

(Continued)

# Fuel System Test Tools

## Additional Service/Repair Parts (Continued)

Warranty: Six Months

Engine Tools

Item	Part No.	Description	Qty.	Where Used
<b>Additional Parts (Continued)</b>				
10	6V-6103	Screw Assembly	--	fixture assembly to bench rails (long)
--	3P-1539	Tube Assembly	8.0	1.60 mm (0.063 in) ID x 533.4 mm (21.0 in) long
--	3V-2744	Hose Assembly	--	#4 (37 degree) [7/16 - 20 thd x 610 mm (24.0 in) long]
--	4L-5937	Injection Pump Fuel Line Assembly	6.0	1.60 mm (0.063 in) ID x 431.8 mm (17.0 in) long
--	6V-7793	Coupling Group	1.0	drive adapt Hartridge 20.00 mm (0.787 in) jaw
--	8N-5132	Clamp	--	for master nozzle

Item	Part No.	Description	Qty.	Where Used
<b>Additional Parts (Continued)</b>				
--	9U-5298	Tube As - Fuel Injection Test	--	1.83 mm (0.072 in) ID x 762.0 mm (30.0 in) long
--	9U-5299	Tube As - Fuel Injection Test	--	1.83 mm (0.072 in) ID x 1270.0 mm (50.0 in) long
--	1U-5223	Fitting	6.0	bleed return for 1P-1795 (discontinued)
--	1T-0416	Bolt	--	for master nozzle
--	9U-6705	Nozzle Master	--	for master nozzle
--	031-2125	Hose Assembly - Hyd	--	#4 (37 degree) [7/16 - 20 thd x 1016 mm (40 in) long]
--	126-1827	Rod	--	drive coupling rotation (Cat <sup>®</sup> heavy duty)

<sup>1</sup> 1P-2333 Knob, is Item 6 and 8

### 135-2916 Mounting Drive Group (Not Serviced)

Model: 3406B, 3406C, and 3406 PEEC Engines

Warranty: Six Months

- Replaces discontinued 6V-4990 Adapter Group
- Used to mount and test fuel injection pumps
- Used with fuel injection equipment test stands (FITB, FIETS, and AVM)
- Tooling is required for off-engine testing of injection pumps
- Parts are serviced separately to reduce dealer cost (no need to purchase tools already in inventory)

#### References

NEHS0594, TMI Specification

NEHS0624, Tool Operating Manual

NEHS0639, Tool Operating Manual

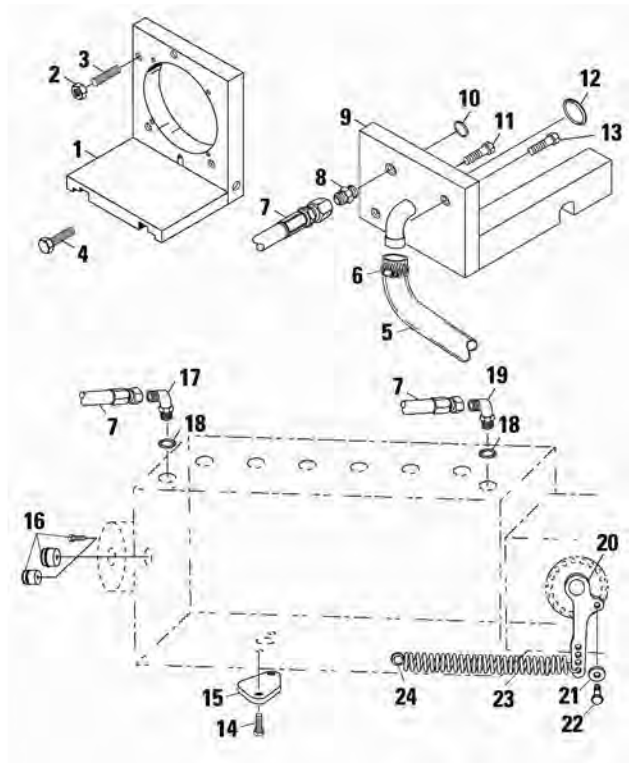

Item	Part Number	Description	Qty.
1	6V-6101	Plate Assembly <sup>1</sup>	1
2	6V-8801	Nut	5
3	1J-8668	Stud	5
4	0L-1143	Bolt	3
5	9U-7709	Drain Tube	1
6	5D-1026	Hose Clamp	1
7	7G-7105	Hose Assembly	3
8	5P-6661	Fitting	1
9	6V-6102	Support Assembly	1
10	1S-0004	O-ring Seal	1
11	0S-1591	Bolt	1
12	3J-1907	O-ring Seal for 5P-9617 Adapter	2
12	8S-5953	O-ring Seal	1
13	3B-1915	Bolt	1

Item	Part Number	Description	Qty.
14 <sup>2</sup>	2A-0762	Bolt	2
15	9U-5297	Cover	2
16	8T-2849	Plug	1
16	4W-4616	Quad Ring Seal	1
16	4W-0435	Quad Ring Seal	1
16	8T-2848	Plug	1
16	7H-2069	Bolt	1
17	030-7947	Elbow Fitting	1
19	1W-3151	Orifice Fitting	1
20	6N-3646	Lever	1
21	5P-0537	Hard Washer	1
23	9M-3858	Spring	1
24	6V-8918	Bolt	1
--	135-2916	Mounting Drive Group (not serviced)	--

<sup>1</sup> Some later 6V-6101 Plate Assemblies do not include shield.

<sup>2</sup> 2A-0762 Bolt, is item 14 (Qty. 2) and item 22 (Qty. 1)

## Additional Required Hardware for 135-2916 Mounting Drive Group

Warranty: Six Months

The following list of hardware is required, but not included as part of the 135-2916 Mounting Drive Group (not serviced). This tooling can be purchased as needed.

### Drive Adapters for 4C-8723 Jaw Assembly

Item	Part No.	Description	Where Used	Qty.
1	6V-6097	Camshaft Drive Adapter Assembly	camshaft drive (10 degree helix with 50 teeth)	--
2	1U-8700	Camshaft Drive Adapter Assembly	camshaft drive (15 degree helix with 50 teeth)	--
3	4C-8249	Camshaft Drive Adapter Assembly	camshaft drive (15.615 degree helix with 52 teeth)	--
4	6V-6099	Camshaft Drive Shield Assembly <sup>1</sup>	--	1
5	4L-7124	Bolt - Hex Socket Head <sup>2</sup>	--	4
6	0L-1143	Bolt	bolt, drive adapter to injection pump cam	3

<sup>1</sup> Some later 6V-6101 Plate Assemblies do not include shield.

<sup>2</sup> Part of 1P-0520 Driver Group

### Drive Adapters for Discontinued 4C-8192 Heavy-Duty Coupling

Warranty: Six Months

Item	Description
4	Pusher Bolt

Item	Part Number	Description	Quantity
1	4C-8193	Camshaft Drive Adapter Assembly	--
2	4C-8194	Camshaft Drive Adapter Assembly	--
3	126-1826	Camshaft Drive Shield Assembly	--
5	0L-1143	Bolt	3
6	8H-0707	Bolt	4

### Adapter Part Numbers and Usage

Usage	4C-8723 Jaw Assembly	4C-8192 Heavy-Duty Coupling Group <sup>1</sup>
3406B PEEC Engine - 8TC, 3406B Truck Engine - 4MG3600-UP, 15 degree Helix with 50 teeth	1U-8700	4C-8193 <sup>2,3</sup>
3406B PEEC Engine - 3ZJ, 3406B Truck Engine - 4MG3600-UP, 15.615 degree Helix with 52 teeth	4C-8249	4C-8194 <sup>2,3</sup>
3406 Truck Engine - 7FB and 4MG3600-DOWN, 10 degree Helix with 50 teeth	6V-6097	6V-6097 <sup>4</sup>

<sup>1</sup> Discontinued

<sup>2</sup> Requires 126-1826 Oil Shield Assembly on 6V-6101 Plate Assembly.

<sup>3</sup> Requires 4C-8189 Drive Tube.

<sup>4</sup> Attach the 4C-8723 Jaw Assembly onto the discontinued 4C-8192 Heavy-Duty Coupling Group.

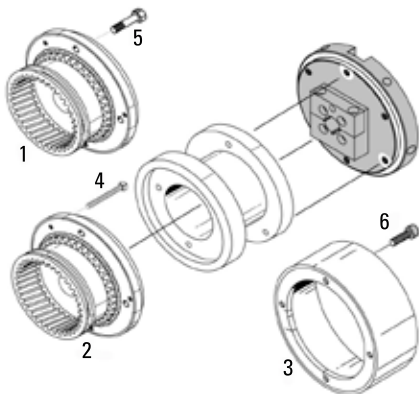
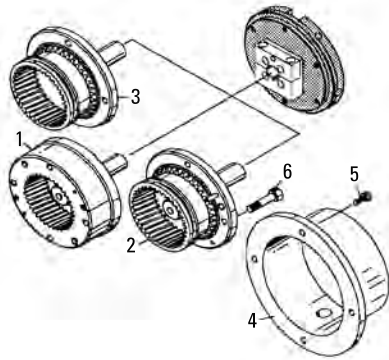

## Test Hardware (PEEC and Non-PEEC Engines)

Item	Part Number	Description	Quantity
1	8T-1002	Position Probe (X4)	1
2	5P-4160	Point - Indicator Contact, 19.05 mm (0.75 in) long	1
3	5P-4814	Collet As - Clamp	1
4	7B-2742	Bolt	1
5	8T-9198	Rack Indicator Bracket Assembly	1
6	0S-1615	Bolt <sup>1</sup>	1
7	9U-6705	Nozzle Master	6
8	9U-5298	Tube As - Fuel Injection Test	6
9	6V-4186	Pin - Fuel Pump Timing	1
10	9U-5296	Rack Positioning Assembly <sup>2</sup>	--
11	4F-7957	Bolt	--

<sup>1</sup>Parts serviced separately.

<sup>2</sup>Non-PEEC, 3406B and 3406C Rack Adjustment

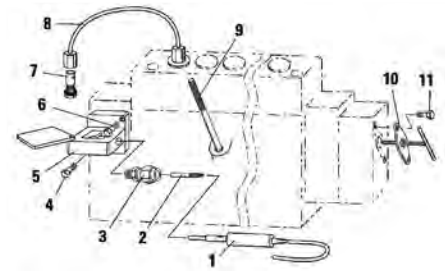

## Rack Positioning Hardware (3406 PEEC Engines)

Item	Part Number	Description
1	9U-5292	Rack Pre-load Assembly
2	9U-5295	Rack Positioning Assembly
3	9U-5120	Spanner Wrench

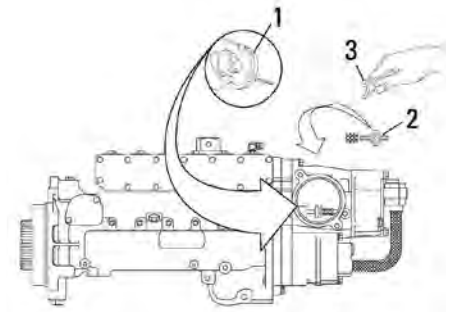

## Zexel and Nippondenso Fuel Pump and Governor Disassemble and Assemble Tools

Model: 3046, 3064 and 3066 Engines

Warranty: Six Months

- Used to disassemble and assemble fuel injection pump and governor
- Makes overhaul of pump and governor simpler and faster
- Using this specialized tooling reduces the risk of part and component damage

### References

SEN6572, Supplement for Fuel Injection Pumps for 3064 and 3066 Engines

SEN6573, Supplement for Fuel Injection Pumps for 3046 Engines

Part Number	Description	Use
4C-6608	Holding Tray	keep parts organized (reduces chance of lost or damaged parts)



## Fixture Group / Mounting Plate



Item	Part Number	Description	Use
1	4C-5602	Fixture Group <sup>1</sup>	hold pump in any position for ease of repair (can greatly increase mechanic's efficiency during overhaul)
2	4C-5603	Mounting Plate	bolts to fuel injection pump and attaches to 4C-5602 Fixture Group; allows attachment of Nippondenso, Zexel, and Stanadyne pump, all to the same plate

<sup>1</sup>Includes support assembly, 4C-5712 Base Assembly, 4C-5715 Bushing, and lock pin assembly

## Assemble Tools for Zexel and Nippondenso Fuel Pump



Item	Part Number	Description	Use
1	4C-5567	Torque Adjusting Socket	remove and adjust torque control spring
2	126-2370	Wrench (3046 only)	remove and adjust torque control spring
2	4C-5085	Wrench (3064 and 3066 only)	remove and adjust torque control spring
3	5P-1720	Seal Pick	remove shims under plunger springs
4	4C-6605	Tweezers	remove and install delivery valve (care must be taken not to damage this part)
5	4C-5574	Seal Protector	Protects seal face during front cover installation (seals can be damaged by camshaft keyway slot, if not protected)
6	4C-4025	Bearing Installer	install bearing on camshaft (reduces bearing damage and part replacement cost)
7	4C-4098	Seal Installer	install seals in front pump cover

## Disassemble Tools for Zexel and Nippondenso Fuel Pump



Item	Part Number	Description	Use
1	4C-5601	Plunger Compressor	compresses plunger spring and roller so plunger holders can be installed and removed
2	4C-6381	Lower Plier	designed to reach through pump case and remove/install plungers
3	4C-6597	Plunger Holder	hold plungers off camshaft so it can be removed or installed
4	4C-5580	Pulling Adapter	removes 4C-4024 Camshaft Holder from camshaft
5	4C-4024	Camshaft Holder	hold camshaft while removing and installing retaining nut that holds flyweights to camshaft
6	4C-6380	Plunger Holder	makes removal and installation of roller much easier

(Continued)



**Disassemble Tools for Zexel and Nippondenso Fuel Pump (Continued)**

Item	Part Number	Description	Use
7	4C-4956	Nut Socket	removes and installs flyweight retaining nut (specially designed)

**195-0768 Thread Adapter**

This adapter is used to adapt the 4C-5601 Plunger Compressor to Zexel pumps with M28 threaded plugs.

**To remove existing M26 thread adapter:**

1. Remove block with spring fingers (heat may be required to loosen thread lock compound).
2. Remove washer and current M26 thread adapter (silver).
3. Install new M28 thread adapter (black oxide).
4. Install washer and block with spring fingers (use 4C-4030 Thread Lock to secure block with spring fingers).

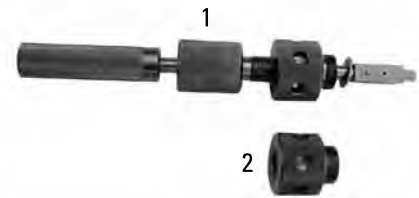

Item	Part Number	Description
1	4C-5601	Plunger Compressor
2	195-0768	Thread Adapter

**Zexel and Nippondenso Fuel Pump and Governor Test and Adjust Tools**

Model: 3046, 3064 and 3066 Engines

Warranty: Six Months

- Used to test and adjust fuel pump and governor after an overhaul
- Used with discontinued 8T-1001 Electronic Position Indicator, 8T-1002 Indicator Probe, 6V-3075 Indicator, and 5P-4163 Indicator Tip

**References**

NEHS0622, Tool Operating Manual, Testing and Adjusting Fuel Injection Pump and Governor on 3064 and 3066 Engines  
 SENR6573, Supplement, Nippondenso Fuel System



Item	Part Number	Description	Use
<b>Mounting Tools</b>			
1	8S-2264	Puller Group	helps remove drive adapter from pump
2	9U-7493	Drive Adapter	attaches pump to test stand drive spindle
3	0T-0722	Bolt	attaches pump to test stand base plate
4	4S-9191	Flat Washer	attaches pump to test stand base plate
5	9U-7494	Pump Mounting Plate	attaches pump to test stand base plate

Item	Part Number	Description	Use
<b>Mounting Tools (Continued)</b>			
6	6V-9138	Clamp Assembly	pump mounting base (part of Fuel Injection Test Stand)
7	0T-0924	Bolt	attaches pump to test stand base plate
8	3B-4506	Lock Washer	attaches pump to test stand base plate
9	6V-9134	Screw Assembly	pump mounting base (part of Fuel Injection Test Stand)

(Continued)

# Fuel System Test Tools

## Zexel and Nippondenso Fuel Pump and Governor Test and Adjust Tools (Continued)

Model: 3046, 3064 and 3066 Engines

Warranty: Six Months

Engine Tools

Item	Part Number	Description	Use
<b>Mounting Tools (Continued)</b>			
10	6V-9132	Fixture Assembly	pump mounting base (part of Fuel Injection Test Stand)
11	118-1713	Washer	attaches pump to test stand drive spindle
12	118-1711	Nut	attaches pump to test stand drive spindle
13 <sup>1</sup>	2A-4639	Bolt	attaches pump to test stand drive spindle

<sup>1</sup>Item 13 includes: item 8, 3B-4506 Lock Washers (2)

<sup>2</sup>See FT2559 for plate modification.

### FT2560 Plate Modification for Guard

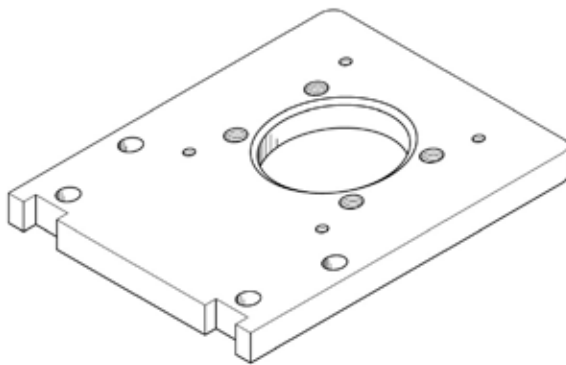

Part Number	Description
FT2560	Plate Modification for Guard

### Adjustment Tools



Item	Part Number	Description	Use
<b>Adjustment Tools</b>			
1	8T-1001	Electronic Position Indicator	obtain measurement specifications
2	8T-1002	Position Probe (X4)	obtain rack measurement specifications
3	6V-3075	Indicator - Dial	obtain measurement specifications
4	5P-4163	Point - Indicator Contact, 120.65 mm (4.75 in) long	obtain measurement specifications
5	4C-2982	Indicator Collet	as an assembly to measure plunger lift
6	4C-5713	Nozzle Overflow Assembly	allows mechanic to see when fuel stops flowing and then check timing angle

(Continued)

**Adjustment Tools (Continued)**

Item	Part Number	Description	Use
<b>Adjustment Tools (Continued)</b>			
7	4C-5085	Wrench (3064 and 3066 only)	adjusts the setting of torque idling screw
8	4C-5567	Torque Adjusting Socket	adjusts the setting of torque idling screw
9	4C-6509	Plunger Spring Retainer	replace adjustment shims (holds plunger spring off top of roller)
10	5P-1720	Seal Pick	replace adjustment shims (holds plunger spring off top of roller)
11	4C-6605	Tweezers	helps to remove and install delivery valve
12	9Y-6051	Locknut	as an assembly to measure plunger lift
13	4C-5604	Copper Washer (2)	as an assembly to measure plunger lift
14	4C-4658	J-tube Fitting	as an assembly to measure plunger lift
15	4C-4766	Plunger Adapter	as an assembly to measure plunger lift

**Calibration Fluid and Lube Line Tooling**

Item	Part Number	Description	Use
1	127-4365	Fuel Injector Test Tube Assembly (6)	connect injection pump to master nozzle
2	4C-4909	Transfer Pump Cover	covers transfer pump opening during testing
3	4C-5708	Copper Washer (2)	returns test oil from pump back to test stand
4	4C-5707	Copper Washer (2)	supplies test oil to fuel pump
5	4C-5706	Copper Washer (2)	supplies lube oil to pump
6	4C-6609	Lube Oil Supply Fitting	supplies lube oil to pump
7	4C-5711	Calibration Fluid Supply Fitting	supplies test oil to fuel pump
8	4C-5710	Calibration Fluid Return Fitting	returns test oil from pump back to test stand

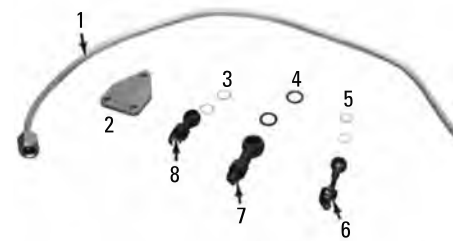

**Indicator Tools**

Item	Description	Use
1	Electronic Position Indicator	obtain rack measurement specifications



(Continued)

## Indicator Tools (Continued)

Item <sup>1</sup>	Part Number	Description	Use
<b>Indicator Tools</b>			
2	8T-1002	Position Probe (X4)	obtain rack measurement specifications
3	5P-4160	Point - Indicator Contact, 19.05 mm (0.75 in) long	obtain rack measurement specifications
4	3P-1567	Indicator	obtain rack measurement specifications
5	4C-5569	Measurement Adapter <sup>2</sup>	attaches indicator to pump for rack measurement
6	4C-2982	Indicator Collet	as an assembly to measure plunger lift
7	146-7774	Nylon Screw <sup>3</sup>	attaches indicator to pump for rack measurement

<sup>1</sup>Item 1: Electronic Position Indicator, Use: obtain rack measurement specifications

<sup>2</sup>Used for FIETS with original coupling

<sup>3</sup>Used for FIETS and AVM with heavy duty coupling

### 146-7780 Rack Position Bracket Group (not serviced)

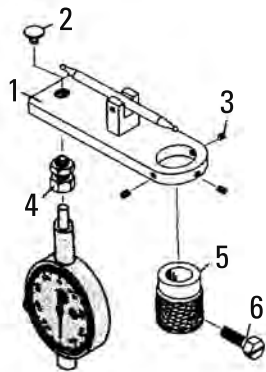

Item	Part Number	Description	Qty.
1	146-7777	Arm Assembly <sup>1</sup>	--
2	6V-2057	Contact Point	1
3	5B-9324	Set Screw <sup>1</sup>	3
4	3P-1565	Collet Clamp	--
5	146-7771	Rack Measurement Adapter <sup>1</sup>	--
6	146-7774	Nylon Screw <sup>1</sup>	1
--	146-7780	Rack Position Bracket Group (not serviced)	--
<b>Not Shown</b>			
--	6V-2030	Extension <sup>1,2</sup>	1

<sup>1</sup>Used for FIETS and AVM with heavy duty coupling

<sup>2</sup>Part of 6V-6042 Indicator Contact Point Group

### 4C-8145 Throttle Control Indicator Group

Sets rack and throttle control angle

Item	Includes
1	Base Assembly and Upper Plate
2	Indicator Assembly and Adjusting Block
3	Column Assembly and Upright Bar
4	Throttle Control Linkage, Sleeve and Pin
5	Adjusting Block and Guide
7	Dial Assembly

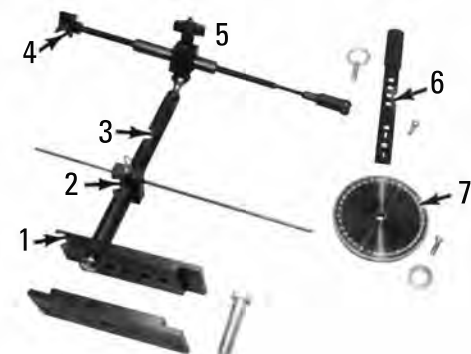

Item	Part Number	Description
1	9X-8873	Bolt
1	4C-8135	Lower Plate
2	4C-8143	Pointer
2	6V-0672	Knob (thumb screw)
3	6V-8183	Nut
3	8R-0739	Washer
3	8T-8889	Bolt
3	4K-4726	Rod End
4	6V-6961	Knob

Item	Part Number	Description
4	4C-8138	Nut
4	4C-8146	Rod End Yoke
5	3W-6756	Knob
5	6V-8189	Nut
7	7S-1114	Spring Washer <sup>1</sup>
7	4M-5281	Bolt
7	4C-8144	Degree Wheel
--	4C-8145	Throttle Control Indicator Group

<sup>1</sup> Not serviced

### Engine Governor Adjustment Tools

#### Essential Tool

Model: C0.5, C0.7, C1.1, C1.5, C1.6 and C2.2 Engines

Warranty: Six Months

- Used to adjust governor on specific model Industrial engines
- Used with 8C-4982 Allen Head Screw (M4 x 20 x 0.70 mm) and 9U-7400 Multitach Tool Group

#### Reference

KENR6228-00, Testing and Adjusting C0.5, C0.7, C1.1, C1.5, C1.6 and C2.2 Industrial Engines

Item	Part Number	Description	Use
1	330-7396	Dial Indicator	graduated in 0.01 mm increments and has a 20 mm (.8 in) long extension tip
2	330-7397	Dial Indicator Holder	fits over indicator shaft and collet locks it in position
3	330-7398	Engine Block Adapter	installs in cylinder block and allows dial indicator holder to thread into adapter
4	330-7399	Spring	replaces start spring during testing and adjusting procedures

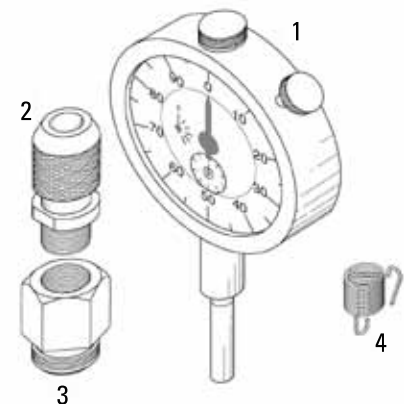

## Injection Pump Off-Engine Disassembly, Assembly, and Bench Test

Model: Early 3054 and 3056 Pre-Emission Engines

Warranty: Six Months



- Used to disassemble and assemble Stanadyne DB2 and DB4 fuel injection pump and governor used on pre-emission 3054 and 3056 engines
- Makes adjustments to fuel pump and governor simpler and faster
- Specialized tooling reduces the risk of parts and/or component damage
- Not for use on 3054-3056 Engines with Stanadyne, Lucas, or Bosch emission pumps

### References

SENR6574, Stanadyne Fuel System (Supplement)

ENG95-1 IRM, for 3054 and 3056 Engine Fuel Systems

Part Number	Description	Use
4C-6608	Holding Tray	keep parts organized (reduces chance of lost or damaged parts)

## Disassembly and Assembly Tools for Injection Pump Off-Engine

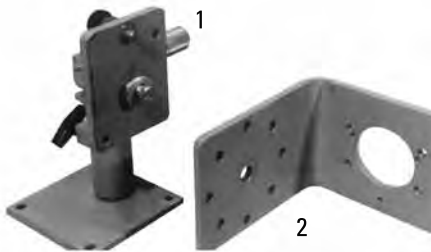

Item	Part Number	Description	Used
1	4C-5602	Fixture Group <sup>1</sup>	disassembly and assembly
2	4C-5603	Plate	hold pump during disassembly and assembly

<sup>1</sup> Includes support assembly, 4C-5712 Base Assembly, 4C-5715 Bushing, and lock pin assembly

## Disassembly and Assembly Tools for Injection Pump Off-Engine

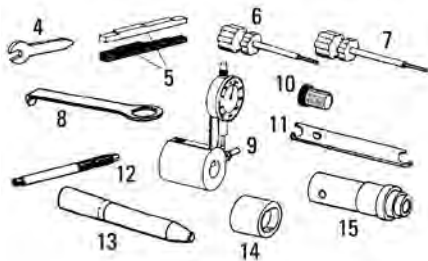

Item	Part Number	Description	Use
<b>Disassembly and Assembly Tools</b>			
10	4C-6621	Bushing	advance cam screw
11	4C-8053	Remover	--
12	4C-8128	Extractor	with screwdriver
13	4C-6829	Installer	install pump shaft
14	4C-6989	Socket	remove pump end cap
15	4C-6841	Mandrel	remove pump bearing
4	4C-6839	Wrench	adjust governor linkage
5	4C-8124	Linkage Kit	set clearance between rear of throttle shaft and vertical tab on linkage hook
6	4C-6842	Screwdriver	set timing trimmer screw
7	4C-6827	Screwdriver	with 4C-8128 to remove delivery valve and stop screw
8	4C-8129	Wrench	remove spring side advance piston hole plug hole plug
9	4C-6845	Fixture	with shop air to measure roller-to-roller dimension

## Bench Mounting Tools and Testing Tools

Item	Description	Use
2	Pump Mounting Plate	mount pump on 6V-9132 Base Plate Rail Adapter

Item	Part Number	Description	Use	Quantity
<b>Bench Mounting Tools and Testing Tools</b>				
1	8S-2264	Puller Group	remove 9U-7493 Drive Adapter from pump	--
2	1U-5366	Pump Mounting Plate	mount pump on 6V-9132 Base Plate Rail Adapter	--
3	0T-0772	Bolt	connect fuel injection pump to mounting plate	3
4	4S-9191	Flat Washer	connect fuel injection pump to mounting plate	3
5	118-1713	Washer	connect 9U-7493 to pump	--
6	118-1711	Nut	connect 9U-7493 to pump	--
7	9U-7493	Drive Adapter	connect 9U-7501 Drive Adapter to bench drive	--
8	8T-6864	Valve Shut-off	--	--
9	9U-7501	Drive Adapter	--	--
10	2A-4639	Bolt	bolt 9U-7501 to 9U-7493	2
11 <sup>1</sup>	5M-2894	Washer	bolt 9U-7501 to 9U-7493	2
12	6V-9134	Screw Assembly	secure base plate to rails	--
13	6V-9132	Fixture Assembly	--	--
14	6V-9138	Clamp Assembly	secure base plate to rails	--
16	0T-0924	Bolt	--	4
17	146-7767	Guard Assembly <sup>2</sup>	--	--
18	2H-0191	Bolt	--	4

<sup>1</sup>Item 11: 2M-2894 Flat Washer (Qty. 2) is also Item 15: 2M-2894 Flat Washer (Qty. 4)

<sup>2</sup>See FT2559 for plate modification.

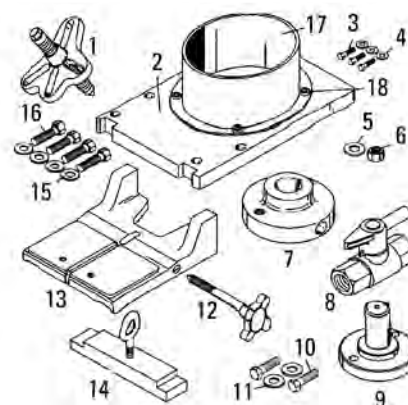

## FT2559 Plate

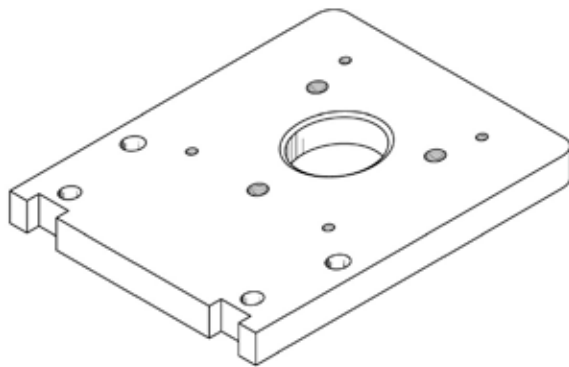

Part Number	Description
FT2559	Plate

## Calibration Fluid and Lube Line Tooling

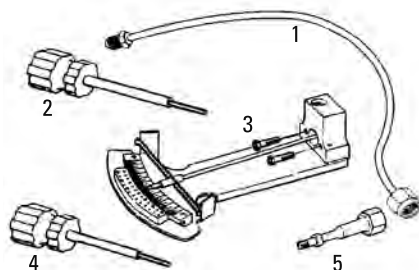

Item	Part Number	Description	Y
1	127-4365	Fuel Injector Test Tube Assembly	connect injection pump to master nozzle
2	4C-6827	Screwdriver	--
3	4C-8126	Indicator Assembly	measure advance
4	4C-6842	Screwdriver	--
5	4C-8054	Tap Fitting	check transfer pump pressure

## 4C-6907 Governor Drive Group

## 4C-8740 Air Supply and Test Group

Model: 3500 and 3600 Family Engines with Woodward 3161 Governors

Warranty: Six Months

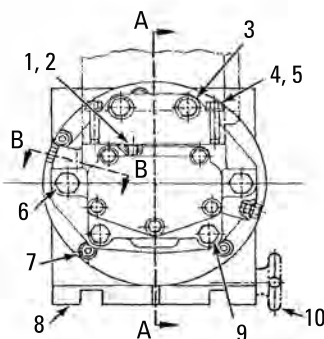

- Used for off-engine bench testing and adjusting Woodward 3161 Governors on Fuel Injection Pump Test Stand
- Used with either Fuel Injection Equipment Test Stand (discontinued 6V-7900, discontinued 1U-8212 or discontinued 1U-8213 made by Hartridge) or non-current fuel injection test bench (made by Kent-Moore) and 4C-6100 Torque Control Tool Group
- Eliminates need for specialized governor test bench
- 4C-6907 Governor Drive Group used to mount and drive 3161 Governor with fuel injection equipment test stand; parts from 1W-2135 Drive Group (used on 3500 Series Engines) were modified and used in drive gear box; modified parts are called out and identified; parts of gear box that were not modified are shown in 3500 Series Engine parts books
- 4C-8740 Air Supply and Test Group contains pressure gauges and regulators to perform pneumatic tests and adjustments

### References

NEHS0545, 3161 Governor Test

SEHS9318, Test and Adjust of 3161 Governors On Fuel Injection Test Stand

SEHS9351, Schedules for On Fuel Injection Test Stand

(Continued)



**4C-6907 Governor Drive Group (Continued)**

**4C-8740 Air Supply and Test Group**

Model: 3500 and 3600 Family Engines with Woodward 3161 Governors

Warranty: Six Months

Item	Part Number	Description	Quantity
--	4C-6907	Governor Drive Group	--
<b>4C-6907 Governor Drive Group - Serviced</b>			
1.0	9F-2247	Pipe Plug	4
2.0	3P-0647	Seal	4
3.0	0S-1621	Bolt	2
4.0	0L-2070	Bolt	4
5.0	5M-2894	Washer	4
6.0	1D-4588	Bolt	2
7.0	1L-0509	Socket Head Cap Screw (3/8-16)	4
8.0	6V-6101	Plate Assembly <sup>1</sup>	--
9.0	1A-7669	Bolt	2
10.0	6V-6103	Screw Assembly	--
<b>Required but not included</b>			
--	4L-7124	Bolt - Hex Socket Head <sup>2</sup>	4
--	6V-6099	Camshaft Drive Shield Assembly <sup>1</sup>	1

<sup>1</sup>Some later 6V-6101 Plate Assemblies do not include shield.

<sup>2</sup>Part of 1P-0520 Driver Group

**Section A-A**

Item	Part Number	Description
11	4C-6906	Adapter
12	4C-6905	Drive Shaft Assembly
13	4C-6904	Pinion
14	4C-6903	Housing Assembly

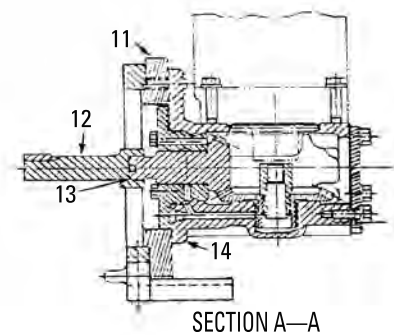

## Section B-B

Item	Part Number	Description	Qty.
15	9S-4182	Plug	2
16	6V-5048	Seal	2
17 and 18	9F-2247	Pipe Plug	2

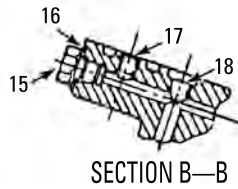

Engine Tools

## 4C-8740 Air Supply and Test Group



Item	Description
6	9.53 mm (3/8 in) Tubing, 0.46 m (1.5 ft)
7	Air Bulb (W.A. Baum Co. Inc. Catalog No. 1890)

Item	Part Number	Description	Size	Qty.
1	8T-0841	Plastic Case	--	--
2	8T-0839	Diff Pressure Gauge	--	--
3	9U-6100	Gauge	--	--
4	4C-3974	Union Fitting	--	4
5	1U-5469	Pressure Gauge	--	--
--	4C-8740	Air Supply and Test Group	--	--
<b>Not Shown<sup>1</sup></b>				
--	8T-0821	Tubing	16 m (52.5 ft)	--
--	4C-3973	Fitting	3.18 x 3.18 mm (1/8 x 1/8in)	4
--	3J-7354	O-ring Seal	--	2
--	5D-9231	Fitting	--	2

<sup>1</sup> Also not shown: Male Connector, 6.35 x 3.18 mm (1/4x 1/8in) (Qty. 2) and Bulkhead Union, 3.18 mm (1/8in) (Qty. 2)

### 4C-6100 Tool Group, 3161 Governor Torque Control

Model: Multiple Engine Models

Warranty: Six Months

- Used to perform variety of in-vehicle engine governor and fuel system settings for D11 Track-Type Tractor and the 777, 785 and 789 Off-Highway Trucks
- Easily installed on governor without removing surrounding components such as alternator or water hoses
- With correct combination of lever arms and weights, a specific torque is applied to 3161 Woodward Governor speeder and terminal shafts; allows for setup of governor, setting fuel injection timing, derating of governor for high altitude applications, and evaluation of governor schedule



Item <sup>1</sup>	Part Number	Description	Weight
1	4C-3975	Plastic Storage Case	--
1	4C-6102	Torque Arm Weight	2.27 kg (5 lb)
2	4C-6099	Torque Arm	--
3	4C-6103	Torque Arm Weight	4.08 kg (9 lb)
4	4C-6101	Torque Arm	--
5	4C-6098	Torque Arm	--
6	4C-6105	Insert	--
--	4C-6100	Tool Group, 3161 Governor Torque Control	--

<sup>1</sup> Not shown: NEEG2435 Decal

### Vehicle Application with Tooling Combinations for 4C-6100 Tool Group, 3161 Governor Torque Control

Vehicle Application with Tooling Combinations		
Tool Usage	Part Number	Description
<b>D11 Track-Type Tractor</b>		
Terminal shaft tools <sup>1</sup>	4C-6102	Torque Arm Weight
Speeder shaft tools <sup>1</sup>	4C-6103	Torque Arm Weight
<b>777, 785 and 789 Off-Highway Trucks</b>		
Terminal shaft tools <sup>1</sup>	4C-6102	Torque Arm Weight
Speeder shaft tools <sup>1</sup>	4C-6103	Torque Arm Weight

<sup>1</sup> Includes: Torque Arm

### 1U-9361 Governor Torque Arm

Model: 3500 Marine and Industrial Generator Sets

Warranty: Six Months

- Used to test and adjust 3161 governor
- Applies consistent torque to governor and fuel system linkage for more accurate fuel system adjustments
- Can be installed on terminal shaft of 3161 governor
- Arm applies 10.3 N·m (7.60 ft·lb) of torque to governor linkage when torque arm is installed with center line of cylinder-shaped weight in horizontal position

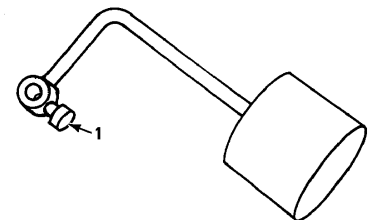

#### Reference

SEHS9240-01, Special Instruction

Item	Part Number	Description
1	3F-7147	Bolt
--	1U-9361	Governor Torque Arm

## 1U-6661 Tester

### Discontinued — Service/Repair Parts Available

#### References

SEHS8867, Using the 1U-6661 Pop Tester

SEHS8858, Using the 6V-4022 Injector Tester to Test 1.1 L Fuel Injectors

SEHS8922, Installation of 1U-6667 Conversion Group

SEHS8884, Unit Injector Test Specifications for 1.1 L Engines, 1.7 L Engines and 3500 Family Engines

NEEG2565, Decals for Pop Tester

Service Magazine, June 6, 1994, pages 8-9

1U-6661 Tester Service/Repair Parts	
Part Number	Description
4C-3407	Spring Ret
4C-3408	Cover
4C-3411	Panel
4C-3413	Back Cover
4C-3414	Screw
4C-3415	Screw
4C-3417	Knob
4C-3420	Torsion Bar Assembly
4C-3422	Vinyl Grip
4C-3423	Needle Valve
4C-3424	Valve Meeting Group
4C-3425	Back Panel
4C-3426	Stopper
4C-3430	Pivot Link
4C-3431	Pump Lever
4C-3432	Clevis Pin
4C-3433	Shaft Top
4C-3434	Lower Pivot
4C-3435	Spring
4C-3437	Shaft
4C-3438	Clevis Pin
4C-3439	Spring

1U-6661 Tester Service/Repair Parts	
Part Number	Description
4C-3440	Connector
4C-3441	Spacer Ring
4C-3442	Nylon Bearing
4C-3443	Bushing
4C-3444	Nylon Bearing
4C-3445	Swivel Stop
4C-3446	Filter Stem
4C-3447	Brass Insert
4C-3448	Connector
4C-3449	Pipe Tee
4C-3450	Pipe Elbow
4C-3451	Check Valve
4C-3452	Pipe Elbow
4C-3453	Connector
4C-3454	Priming Valve
4C-3455	Connector
4C-3456	Valve Check
4C-3457	Pipe Nipple
4C-3458	Pipe Connect
4C-3459	Line Return
4C-3460	Pipe Elbow
4C-3461	Pipe Elbow

1U-6661 Tester Service/Repair Parts	
Part Number	Description
4C-3462	Hose Assembly
4C-3463	Swivel
4C-3464	Pipe Elbow
4C-3465	Line
4C-3466	Pipe Connector
4C-3467	Line Gauge
4C-3468	Insert
4C-3469	Washer
4C-3470	Squeeze Bulb
4C-3471	Lines Group
4C-3474	Cap
4C-3475	Bushing
4C-3476	Primary Pump
4C-3477	Ring
4C-3478	O-ring
4C-3479	Piston
4C-3482	Sleeve
4C-3483	Pad
4C-3485	O-ring Seal
4C-3487	Cylinder
4C-3658	Col Spring
4C-9674	Screw
1U-6661	Tester

## 6V-4172 Injector Sleeve

Model: D11N, 3508, 3512, 3516, 777B, 785, 789, 3500

Warranty: Six Months



- Used to cover fuel ports when cleaning injectors on D11N, 777B, 785, 789, and 3500 Series Engines

Part Number	Description
6V-4172	Injector Sleeve

**5P-4150 Nozzle Tester Group**

Model: 1100, 3100, 3208, 3400

Warranty: Six Months

- Used to test all fuel nozzles, including pencil-type nozzles on 1100 and 3100 Series and 3208 Engines, direct injection capsule-type fuel nozzles on 3400 Series Engines, and capsule-type nozzles used on all other engines

**Reference**

SEHS7292, Special Instruction

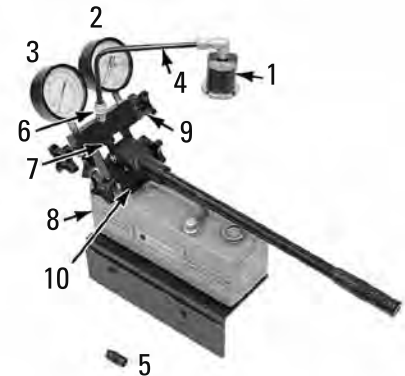

Item	Part Number	Description	Notes
1	5P-8744	Adapter Assembly	If desired, quick disconnect fittings may be installed for faster changing of nozzle adapters; refer to Engine News of October 3, 1979, for installation instructions
3	8T-0856	Gauge	6000 kPa (870 psi) SEHS7605 Caution Label
4	5P-4721	Tube	End fittings not included; included with 5P-4719 and 5P-4720
5	5P-4244	Adapter	--
6	5P-4719	Fitting	Includes connecting fitting for 5P-4721
7	5P-4243	Fitting	--
8	8T-5313	Filter	--
9	4J-7533	Seal	one on each hand valve, qty. 5
10	6V-0183	Gasket	between reservoir and pump
11	8T-0859	Gauge - Pressure	25000 kPa (3600 psi)
--	5P-4150	Nozzle Tester Group	--
<b>Available separately (not shown)</b>			
--	1U-9578	Repair Kit	--

**Service/Repair Parts for 5P-8744 Adapter Assembly (Sold Separately)**

Item	Description
2	Adapter
3	Retainer

Service/Repair Parts for 5P-8744 Adapter Assembly (Sold Separately)		
Item	Part Number	Description
1	5P-4720	Fitting <sup>1</sup>
2	5P-8741	Adapter
3	5P-8740	Retainer
4	5P-8742	Piston Assembly
5	2S-4663	Seal

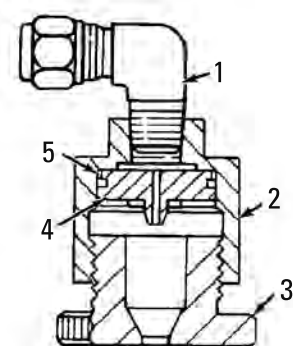

<sup>1</sup> Includes connecting fitting for 5P-4721

## 1U-9578 Repair Kit

Model: Cat® Engines

Warranty: Six Months

- Used to disassemble and assemble 5P-4150 Nozzle Tester Group
- Contains gaskets, seals, O-rings, steel balls and filter, along with printed parts breakdown if parts not included in the kit are needed
- Allows worn or broken 5P-4150 Nozzle Tester Group to be repaired and put back into operation when used along with other service parts listed in Tool Guide

Part Number	Description
1U-9578	Repair Kit

## 5P-7448 Adapter

Model: Flat Seat Fuel Injection Valves

Warranty: Six Months



- Used to test and adjust flat seat fuel injection valves on 5P-4150 Tester and also discontinued 1P-1795 Master Valve from fuel injection test bench

Part Number	Description
5P-7448	Adapter <sup>1</sup>

<sup>1</sup> Not included with tube assemblies, must be ordered separately

## 8S-2270 Fuel Collector

### 1U-8857 Extension Tube and FT1384 Extension

Model: All Fuel Systems

Warranty: 1U-8857: Six Months

1U-8857  
FT1384



8S-2270

#### 1U-8857 Extension Tube

- Used with 8S-2270 Fuel Collector to collect spray from 5P-4150 Nozzle Tester or 8S-2242 Nozzle Tester
- Increases height of 8S-2270 Fuel Collector to prevent splashing of test fluid; made of plastic and can be cut shorter to meet varying heights required by different mounting arrangements of Nozzle Tester Group
- Originally offered as FT1384 drawing, dealer now has option of purchasing or fabricating because the necessary plastic is difficult to purchase in some areas

Part Number	Description
FT1384	Extension

Part Number	Description
1U-8857	Extension Tube
8S-2270	Fuel Collector

**Tube Assemblies**

Model: D6D, 528, 3300, 3046, 3054, 3056, 3064, 3066

Warranty: Six Months

- Used with 5P-4150 Nozzle Tester and 5P-7448 Adapter to test fuel nozzles in 3300 Series DI Engines
- 6V-2170 and 5P-7448 are used on 3054, 3056, 3064 and 3066 Engines (14 mm x 1.5 thd)
- 5P-4718 Adapter is used for, 3034 and 3046 Engines (12 mm x 1.5 thd)



Item	Part Number	Description	Used to Test
1	6V-2170	Tube Assembly	8N-7001 Fuel Nozzle <sup>1</sup>
2	6V-2171	Tube Assembly	7N-0449 Fuel Nozzle
3	3J-1906	Nut (Part of 6V-2170 and 6V-2171)	--
4	3J-1905	Sleeve (Part of 6V-2170 and 6V-2171)	--
5	5P-7448	Adapter <sup>2</sup>	--
Not shown	5P-4718	Adapter (not included with tube assemblies; must be ordered separately)	--

<sup>1</sup>Discontinued

<sup>2</sup>Not included with tube assemblies, must be ordered separately

**FT1743 Line Assembly**

Model: Fuel Systems

Warranty: None

- Used to test 8N-7006, 8N-7007, 4W-7012 and 4W-7013 Fuel Nozzles
- Designed to be used with 5P-4150 Nozzle Tester Group
- Attached to 5P-4721 Tube by using 5P-4244 Adapter (parts of Nozzle Tester Group)

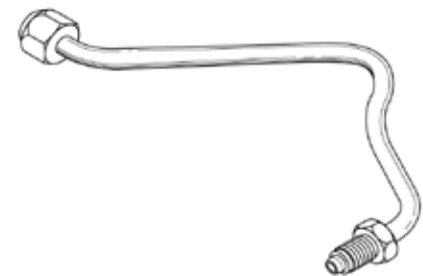

**Reference**

SEHS7292, Special Instruction

**1U-7326 Governor Calibration Bench**

Model: 3114, 3116, and 3126 MUI Engines

Warranty: Six Months

- Used to disassemble, assemble, test, and calibrate governor groups
- All tools in 1U-7326, 1U-9087 (not serviced), and 1U-9088 (discontinued) are serviced separately (groups can be assembled ordering only tools not currently in a dealers inventory)
- Tools are required to service various governor groups, including Type V (1994 truck versions) and type VI (dual horsepower) governors

**1U-7326 Governor Calibration Bench**

- Used to adjust governor on 1.1 Liter Engines
- Used with 9U-7401 Multitach II, 9U-5104 LED Photo Pickup, and 4C-3024 Charger (not included) to read speed



**References**

SENR6454, Service Manual, Governor

SEHS8868, Special Instruction, Using the 1U-7326 Governor Calibration Bench

(Continued)

## 1U-7326 Governor Calibration Bench (Continued)

Model: 3114, 3116, and 3126 MUI Engines

Warranty: Six Months

Part Number	Description
1U-7326	Governor Calibration Bench
<b>Service/Repair Parts</b>	
4C-4167	Motor Pump Unit, 230 VAC
4C-4168	Motor Pump Unit, 115 VAC <sup>1</sup>
4C-4169	Pump Inlet Strainer/Filter
8F-0212	O-ring for Collector Cup
9U-6629	Oil Gearbox

<sup>1</sup>230 VAC single-phase power is not always available to operate 1U-7326 Governor Calibration Bench; 4C-4168 is the only special part needed to convert 1U-7326 to 115 VAC operation so it can be plugged into any 20 A, 115 V outlet.

## 1U-9088 Governor Disassembly and Assembly Tool Group

Discontinued

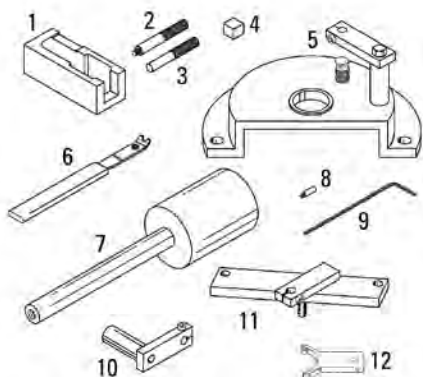

- Used to disassemble and assemble governor groups (many tools in this group were part of discontinued 1U-7315 Governor Repair Group)
- Used with 1U-7326 Governor Calibration Bench
- 1U-7606 Servo Disassembly and Assembly Block — properly positions governor assembly to disassemble and assemble output clevis from servo piston, and press backup spring pin in or out (can also be used on older style servos to safely hold assembly while driving spring pin in or out)
- 1U-7635 Servo Disassembly Driver — used to push servo valve shoulder to avoid damaging valve when removing output clevis from servo piston (use with 1U-7606)
- 1U-7636 Servo Assembly Driver — used to press output clevis into servo piston (use with 1U-7606)
- 6V-9072 Piston Seal Guide — guides new fuel ratio control piston and seal into housing

Not Shown	
NEEG2650	Decal

Service/Repair Parts		
Item	Part Number	Description
1	1U-7606	Servo Block
2	1U-7635	Clevis Driver
3	1U-7636	Servo Driver
4	1U-7313	Gauge Block
5	1U-7309	Shim Adjustment Tool (Governor Riser)
6	4C-4354	Applicator
7	1U-7314	Shim Weight
8	9S-0229	Contact Point
9	1U-7311	Torque Wrench (1.5 mm hex-torque cam adjust)
10	1U-7308	Shim Adjustment Tool (governor spring)
11	1U-7310	Torque Adjustment Tool
12	9U-5120	Spanner Wrench
--	1U-9088	Governor Disassembly and Assembly Tool Group

(Continued)



**1U-9088 Governor Disassembly and Assembly Tool Group (Continued)**

Discontinued

Service/Repair Parts		
Item	Part Number	Description
Not shown <sup>1</sup>		
1	6V-7145	Case
--	1U-7307	Governor Repair Fixture
--	1U-7637	Foam Insert Set
--	6V-6106	Dial Indicator
--	8S-3675	Point - Indicator
--	1U-7312	Calibration Plate

<sup>1</sup>Also not shown: NEEG2650 Decal

**FT2804 Bracket and FT2805 Plate**

- Used to hold 9U-7401 Multitach II onto 1U-7326 Governor Bench
- Used with 1U-7326 Governor Bench
- Allows Multitach II to read governor speed
- Both FT tools are made from SAE 1018 steel

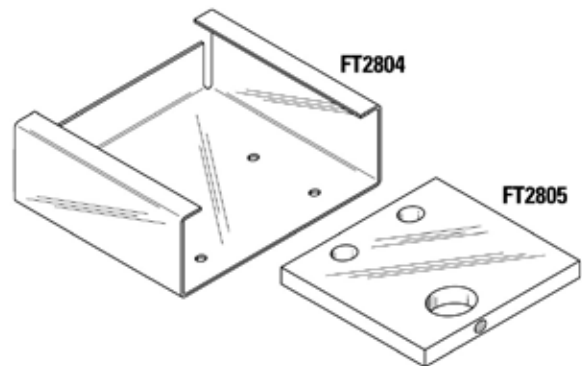

**1U-9087 Governor Adjust Tool Group (Not Serviced)**

- Used to calibrate governors (some tools in this group were part of discontinued 1U-7315 Governor Repair Group or 9U-6880 Throttle Lever Tool Group)
- Used with 1U-7326 Governor Calibration Bench
- 1U-7299 Adjusting Wrench — adjusts governor output (load stop) position and fuel ratio control setting on Type V and later model governors (used with 1U-7300)
- 1U-7431 Adjusting Tool — adjusts low power load stop setting on Type VI governors (used with 1U-7300)
- 1U-7316 Calibration Pin Group — used to calibrate Type V and later model governors and is designed to avoid interference with fuel ration control (cannot be used for on-engine fuel setting adjustment)



Not Shown	
NEEG2649	Decal

Item	Part Number	Description
1	4C-9594	Wrench, 1/2 in (low idle adjustment)
2	1U-5548	Wrench, 8 mm (high idle adjustment)
3	5P-4205	Wrench <sup>1</sup>

Item	Part Number	Description
4 <sup>2</sup>	1U-6673	Wrench - Fuel Ratio Control Adjusting and Synchronizing
5	1U-6672	Rack Adjusting Wrench

(Continued)

## 1U-9087 Governor Adjust Tool Group (Not Serviced) (Continued)

Engine Tools

Item	Part Number	Description
6	1U-7299	Adjustment (FRC) Wrench ("Type V" 1994 and later Trucks)
7	1U-7300	Wrench (3 mm Hex)
8	1U-8815	Point - Indicator Contact
9	1U-7316	Calibration Pin Group
10	1U-7431	Adjusting Tool (dual horse-power screw)
--	1U-9087	Governor Adjust Tool Group
<b>9U-6880 Throttle Lever Tool Group Serviced</b>		
11	9U-6877	Thrust Bearing
12	9U-6876	Puller Stud
13	9U-6874	Puller Bracket
14	9U-6875	Shoulder Screw

Item	Part Number	Description
<b>9U-6880 Throttle Lever Tool Group Serviced (Continued)</b>		
15	9U-6883	Pusher Block Assembly
16	9U-6881	Adjustable Arm Assembly
18	9M-1974	Washer
19	6V-0299	Full Nut
20 <sup>3</sup>	369-2607	Digital Indicator
<b>Not Shown</b>		
1	6V-3072	Case - Plastic, NEEG2574 Group Decal on lid (9U-7402 Group)
3	9U-5120	Spanner Wrench
--	9U-6885	Top Cover Assembly
--	5P-8245	Hard Washer
--	6V-6106	Dial Indicator

<sup>1</sup> Warranty: Six Months

<sup>2</sup> 159-1783 Fuel Ratio Control Adjusting Wrench is 51 mm (2 in) shorter than 1U-6673; required for 3116-3126 Engines in Challenger 35, 45, and 55

<sup>3</sup> 369-2607 Digital Dial Indicator (not part of group, but shown)

## 159-1783 Fuel Ratio Control Adjusting and Synchronizing Wrench

### Essential tool

Model: 3114, 3116, 3126 MUI Engines Used in Challenger 35, 45, and 55 Tractors

Warranty: Six Months



- Used to adjust fuel ratio control (similar to 1U-6673)
- Shorter length provides necessary clearance for Challengers
- May be used in place of 1U-6673 for most applications
- Overall length: 145.9 mm (5.74 in)
- Hex wrench size: 2 mm

#### References

SENR6454, Service Manual, Governor  
SEHS8868, Special Instructions, Using the 1U-7326 Governor Calibration Bench

Part Number	Description
159-1783	Fuel Ratio Control Adjusting and Synchronizing Wrench

## 148-3605 Wrench

Model: 3116 Engines

Warranty: One Year

Part Number	Description
148-3605	Wrench

Model: 3116 Engines

- Replaces discontinued 131-5009 Wrench
- Used to remove and install tamper resistant plugs on 3116 governors installed after 01/01/96
- Used with standard socket and ratchet or flat wrench
- Short hex design works well in confined spaces
- 3/8 square drive (required for dual Hp governors)
- Tamper resistant plugs protect load stop and fuel air ratio control settings on some Type IV governors and fuel air ratio control setting only on some Type V governors
- Hex head diameter: 22.23 mm ( 7/8 in)

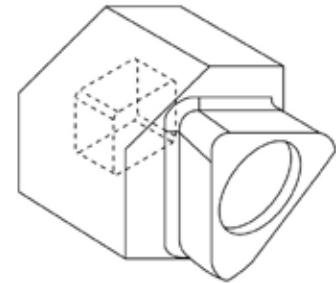

### Reference

SENR6454, Service Manual Module, 3114/3116 and 3116 Engine Governors (MUI)

## 4C-9309 Adapter

Model: 3114, 3116

Warranty: Six Months

Part Number	Description
4C-9309	Spanner Pin Group

- Used to test 2.3 gain governor (available in 1991) for 1.1 L Engines on 1U-7326 Governor Calibration Bench (adapters for earlier pumps included with 1U-7326)
- Used on governor transfer pump outlet fitting
- Use 3K-0360 or 8M-5260 O-ring Seal with adapter

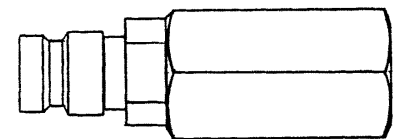

### Reference

SEHS8868, Special Instruction

## Fuel System Tools

### Essential Tool

Model: C4.4 and C6.6 Engines

Warranty: Six Months except 298-5564 which is Manufacturer's Lifetime

#### 300-4988 Fuel Leak Kit

- Used to measure fuel leak rates on C4.4 and C6.6 engines
- Aids in diagnosing faulty fuel injectors on hard-to-start engines

#### 298-5564 T40 Torx Socket

- Used to install injector hold down bolt on C4.4 and C6.6 engines
- Eliminates risk of damaging injector or inlet rocker arm
- 3/8 inch square drive with T40 Torx bit
- Overall length: 114.3 mm (4.5 in)



(Continued)

## Fuel System Tools (Continued)

### Essential Tool

Model: C4.4 and C6.6 Engines

Warranty: Six Months except 298-5564 which is Manufacturer's Lifetime

#### References

SEBD9416, Service Manual (298-5564)

TIBU4874, Bulletin (300-4988)

Part Number	Description
300-4988	Fuel Leak Kit
298-5564	T40 Torx Socket

Engine Tools

### 301-1501 Air-in-Fuel Test Kit

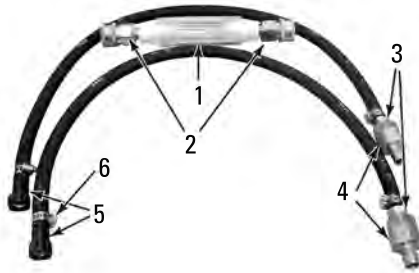

- Used to check for air in fuel in C4.4 and C6.6 engines

Item	Part Number	Description
--	301-1501	Air-In Fuel Test Kit
Service/Repair Parts		
1	2P-8278	Fuel Flow Tube
2	3P-2233	Coupler Assembly
3	102-5758	Hose End
4	3P-2234	Nipple
5	215-9513	Connector
6	124-6275	Hose Clamp

### 304-3107 Pressure Adapter



- Used to check transfer pump pressure on C4.4 and C6.6 engines

Item	Part Number	Description
--	304-3107	Pressure Adapter
Service/Repair Parts		
1	8T-0854	Gauge
2	6V-1739	Pipe Reducing Tee
3	3P-2236	Nipple
4	3P-2233	Coupler Assembly

### 334-3221 Nozzle

#### Essential Tool

Model: C6.4 Engines

Warranty: Six Months

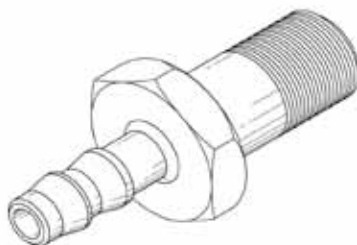

- Used to connect fuel leak kit to 297-7658 Manifold Block (for measuring test fuel system leaks)
- Used with 300-4988 Fuel Leak Kit
- M14 x 1.5 threaded end installs into manifold block
- Barbed end fits 8.25 mm (5/16 in) ID hose from fuel leak kit

Part Number	Description
334-3221	Nozzle

### FT1979 Forcing Screw Assembly

Model: 3204 Engine  
 Warranty: None

- Used to remove fuel injection pump housing and governor from 3204 Engine in D3C, D4C, IT12, 931C, 935C
- Mounts in timing gear cover in place of cover plug and forces fuel injection pump camshaft out of its drive gear
- Consists of 6V-2467 Bolt and bored and tapped 4B-8586 Plug



#### Reference

SENR4038, Disassembly and Assembly Service Manual Supplement for IT12 Integrated Toolcarrier 3204 Vehicular Engine (fuel injection pump housing and governor removal procedures)

### 323-3949 and 362-9754 Fuel Delivery Test Kits

Model Usage: C6.6, C4.4 Engines  
 Warranty: Six Months

- Used to check volumetric flow rates for high-pressure rail fuel systems
- Provides a method to flush fuel outlet ports on high-pressure rail fuel systems
- Steel fitting, orifice, and tube assembly connects to each outlet individually
- Includes five high-pressure cap assemblies to block fuel outlets not being tested
- Drilled orifice meters fuel flow at a precise rate
- Volumetric fuel flow (volume over a specific time) from each outlet, can be compared to determine if fuel pump output is acceptable

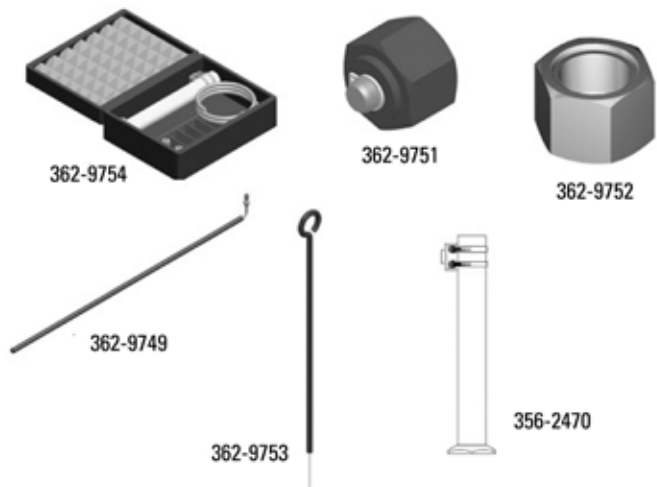

#### Reference

KENR6938 High Leakoff of the Electronic Unit Injector on C6.6 and C4.4 Engines

Part Number	Description
356-2470	Graduated Cylinder
362-9749	Discharge Orifice Assembly
362-9751	Rail Plug Assembly
362-9752	Nut
362-9753	Pin Gauge

## 370-4657 Rocker Arm Assembly Aid

Model Usage: C7.1, C6.6, C4.4

Warranty: Six Months

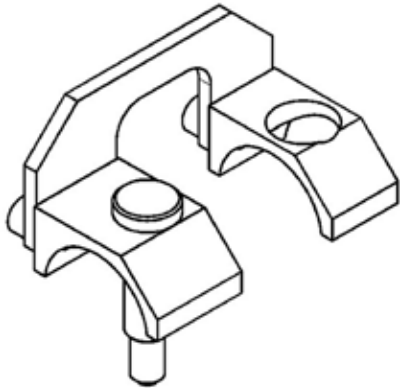

- Used to hold rocker arms in place for assembly and disassembly
- One required for each cylinder

Specifications	
Dimensions	59 x 52 x 37 mm (2.3 x 2.0 x 1.5 in)
Weight	0.08 kg (0.18 lb)

Part Number	Description
370-4657	Rocker Arm Assembly Aid

## 367-8608 Engine Timing Pin

Model Usage: C7.1, C6.6, C4.4

Warranty: Six Months

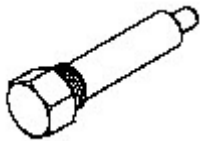

- Determines when crankshaft is positioned at top dead center
- Locks crankshaft in TDC position

Specifications	
Dimensions	87 x 22 x 22 mm (3.4 x .87 x .87 in)
Weight	.14 kg (.31 lb)

Part Number	Description
367-8608	Engine Timing Pin

Fuel System Repair and Adjust

**Connector Assemblies**

**Essential Tool**

Model: C175-16 Engine - S/N WYB1-UP

Warranty: Six Months

- Used to back flush common rail fuel system on C175 Engines
- Used with 295-5490 Filter Cart, 170-8500 Particle Analyzer, and various cap/plugs (part of 276-7018 Cap and Plug Kit)
- Provides a method of flushing fuel systems on C175 engines with out removing fuel system components

**Reference**

SEBF9107, Reuse and Salvage Guideline, Procedure for Back Flushing the Common Rail Fuel System of C175 Engines  
 SEBF9109, Reuse and Salvage Guideline, Handling Procedures for the Components of the Common Rail Fuel System for C175 Engines  
 PEBJ0002, Caterpillar Dealer Contamination Control Guidelines  
 PEBJ9180, Contamination Control Guideline, Diesel Fuel Cleanliness By Particle Analyzer  
 RENR7466, Disassembly and Assembly, C175-16 Generator Set Engine  
 RENR9338, Systems Operation, Testing and Adjusting, C175-16 Generator Set Engine  
 RENR9339, Troubleshooting, C175-16 Generator Set Engine  
 NEHS0799, 170-8500 Analyzer Group Tool Operating Manual

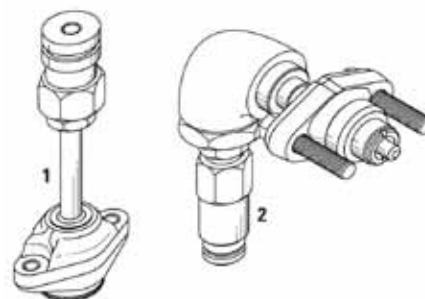

Engine Tools

Includes:	
FT1979	Forcing Screw Assembly

Item	Part Number	Description	Use
1	330-7185	Connector Assembly	installed in place of high pressure fuel line on number two cylinder
2	334-4442	Connector Assembly	installed in place of high pressure fuel line at pump outlet
--	301-1501	Air-In Fuel Test Kit	--
--	304-3107	Pressure Adapter	--

**Timing Fixture Plates**

Model: Cat® Engines

Warranty: Six Months

- Used to time accessory drive shaft to engine with fuel pump housing and governor removed

Part Number	Engine
8S-5417	4.75 in Bore, 4- and 6- Cylinder 2-valve engines (scroll pumps)
8S-4625	951B Traxcavator with 4.5 in Bore engine and hydraulic governor
5P-0143	3204 Engine
5P-4240	D8K Engine (14 degree 17 in timing)



## 8T-5246 Engine Timing Indicator Group

Model: Multiple Engine Models

Warranty: Six Months

- Used to determine piston true top dead center (TDC) and fuel injection pump timing of most Cat® engines
- Replaces discontinued 3S-2954 Indicator Group
- Components for timing each engine in accordance with procedure described in Special Instruction SMHS7083 listed in application chart below
- 6V-2056 Rod and 6V-2057 Contact Point available separately for 3300 Series DI Engines

Model	Adapter	Rod	Contact Point	Dial Indicator and Collet
D336,1676	8T-5340	3S-3264	9S-8883	6V-3075,5P-4814
1100 and 3100 Series 3208, 3204 and 3406 DI <sup>1</sup>	8T-3206	8S-2296	9S-8883	6V-3075,5P-4814
3204 PC <sup>2</sup>	8T-5339	3S-3264	9S-8883	6V-3075,5P-4814
3300 Series DI <sup>1</sup>	8T-3206	6V-2056	6V-2057	6V-3075,5P-4814
3400 Series DI	8T-5340	3S-3264	5P-7261	6V-3075,5P-4814
3400 Series PC <sup>2</sup>	8T-5340	3S-3264	5P-2393	6V-3075,5P-4814
D353, D379, D398, D399	8T-5338	3S-3264	5P-6531	6V-3075,5P-4814
Engines Not Listed Above <sup>2</sup>	8T-5338	3S-3264	5P-7261	6V-3075,5P-4814
3406A	8T-3205	3S-3264		6V-3075,5P-4814
3406B, 3408B, 3412B	8T-3206	5S-8090	6V-2057	6V-3075,5P-4814
<sup>1</sup> DI — Direct Injection				
<sup>2</sup> PC — Precombustion Chamber				



Item <sup>1</sup>	Part Number	Description	Size
1	3S-3269	Contact Point	25.40 mm (1 in)
1	5P-6531	Point	57.20 mm (2.25 in)
1	5P-7276	Container	--
1	8S-3675	Point - Indicator	3.10 mm (0.12 in)
1	6V-2057	Contact Point	3.17 mm (0.12 in) <sup>2</sup>
1	3S-3268	Point - Indicator Contact	6.35 mm (0.25 in)
1	9S-8883	Contact Point	12.70 mm (0.50 in)
1	5P-7261	Contact Point	31.80 mm (1.25 in)
1	5P-2393	Contact Point	38.10 mm (1.50 in)
1	5P-4809	Point Indicator	50.80 mm (2 in)
1	3S-3270	Point - Indicator Contact, 44.45 mm (1.75 in) long	44.50 mm (1.75 in)
2	6V-3075	Indicator - Dial	--
3	5P-4814	Collet As - Clamp	--

(Continued)



## 8T-5246 Engine Timing Indicator Group (Continued)

Model: Multiple Engine Models

Warranty: Six Months

Item <sup>1</sup>	Part Number	Description	Size
4	6V-6105	Block	--
5	6V-3072	Case - Plastic, NEEG2574 Group Decal on lid (9U-7402 Group)	--
6	8T-5247	Block (not serviced)	--
7	8T-5339	Adapter	--
8	8T-5340	Adapter	--
9	8T-5338	Adapter	--
10	3S-3264	Rod	180.90 mm (7.12 in)
11	8S-2296	Rod	133.40 mm (5.25 in)
12	8T-3206	Adapter	--
13	9S-0239	Adapter Assembly	--
14	5S-8090	Rod Assembly	--
15	6V-2056	Rod Assembly	--
16	1T-0416	Bolt	--
17	8N-5132	Clamp	--
18	8T-3205	Adapter	--
--	8T-5246	Engine Timing Indicator Group	--

<sup>1</sup>Item 6: 8T-5247 Block (Not serviced)

<sup>2</sup>9.52 mm (0.375 in) diameter flat face

## 6V-6175 Torque Adapter

## 4C-9874 Torque Adapter

Model: D25C, 3304B, 3306B

Warranty: Six Months

Part Number	Description
4C-9874	Torque Adapter
6V-6175	Torque Adapter

- 4C-9874 replaces discontinued 6V-6176 Torque Adapter
- Bolted to fuel pump drive gear on 3300 Series Engines so that specific torque can be applied to gear by tightening center bolt to specified torque value
- 6V-6175 Adapter used on standard engines; 4C-9874 Adapter used on engines with automatic timing advance
- Both adapters have 1/2 inch square drive



## 2P-8256 Timing Decal

Model: 1100, 3100

Warranty: Six Months



- Attach to crankshaft pulley or damper pulley on 1100 and 3100 Series Engines as alternate method for flow checking static timing without removing rocker arm shaft and injection nozzle

Part Number	Description
2P-8256	Timing Decal

## 5P-0950 Timing Plate

Model: 1100, 3100, 3208

Warranty: Six Months



- Used to time fuel injection pump and governor with front cover removed

Part Number	Description
5P-0950	Timing Plate

## 4C-9287 Timing Advance Holding Tool

Model: 3406B

Warranty: Six Months



- Used when pin timing 1988 and newer 3406B Engines, serial numbers 4MG3600 and up, that have large cone-type retainer on fuel timing advance
- Mounted on timing advance
- Required to hold timing advance at bottom of its travel (retarded position) while pin timing engine; if not used, position can slip and proper timing is not achieved

### Reference

SEBR0544-02, Truck Engine Manual

Part Number	Description
4C-9287	Timing Advance Holding Tool

## 127-1069 Timing Pin

Model: 3054 and 3056 Engines

Warranty: Six Months

- Used to set engine piston at 100° before top dead center (BTDC) when timing Lucas fuel pump (at this location, the piston can be more accurately set to a specific position)
- Whistle on top of timing pin confirms that piston is on compression stroke
- Installs into nozzle bore and is held in place with nozzle clamp
- Material: SAE 1020 steel

### Reference

SENR6525, Supplement, Lucas Fuel System



Part Number	Description
127-1069	Timing Pin

## 329-6925 Timer Tool Assembly

### Essential Tool

Model: 3054B Engine

Warranty: Six Months

Part Number	Description
329-6925	Timer Tool Assembly

- Used to remove and install balancer (maintains timing)
- Also used during disassembly and assembly of balancer
- Black oxide coated for corrosion resistance

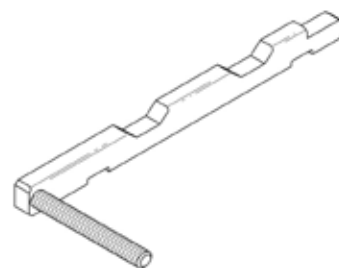

## Timing Setting Tools

### Essential Tool

Model: 3054E and 3056E Engines

Warranty: Six Months

- Used to set timing of engine

Item	Part Number	Description	Engine Used On
1	230-6283	Locking Pin	3054E
2	231-8848	Balancer Fitting Pin	3054E
3	231-8849	Locking Pin	3054E
4	230-6284	Locating Pin	3054E
5	226-2270	Timing Piston	3056E
6	226-2268	Plug Installer	3056E

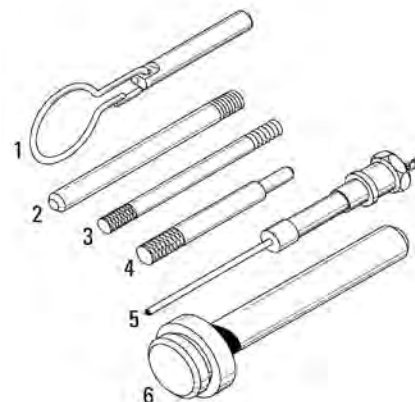

## 136-4632 Timing Pin

## 220-2793 Timing Pin

Model: 1.1L, 1.2L, 3300, 3176 and 3400 Engines

Warranty: Six Months

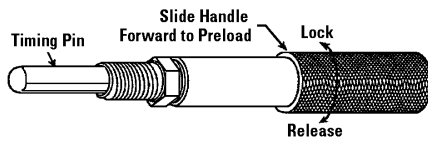

- Used to determine when crankshaft is positioned at top dead center
- Spring loaded pin presses against flywheel; as engine is rotated pin will drop into hole as number one cylinder reaches TDC
- Adapters furnished to fit models listed with sufficient clearance behind timing hole
- Easier to use than a bolt — allows one man operation
- Hardened pin to resist bending
- No adapter needed for 3300 and 3400

Part Number	Description	Size	Use
136-4632	Timing Pin	--	--
220-2793	Timing Pin	--	--
139-7064	Timing Pin Adapter	1/2in - 20	3176 C10/12 Engines
139-7063	Timing Pin Adapter	7/16in - 201	1.1 and 1.2 L Engines

## 208-9387 Timing Pin, 208-9388 Adapter

### Essential Tool

Model: 3176C Engine, D7R Track-Type Tractor and C-9 Engine, D6R Track-Type Tractor

Warranty: Six Months

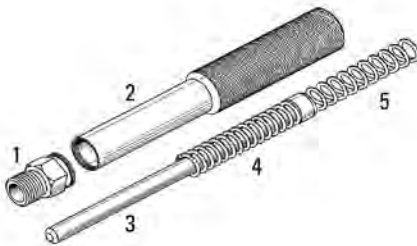

- Pin and adapter allows use of 136-4632 Timing Pin with D6R and D7R flywheel housings
- Used with 208-0888 Crankshaft Turning Tool
- Easily determines when crankshaft is positioned at top dead center
- Spring loaded pin presses against flywheel. As engine is rotated pin drops into hole when number one cylinder reaches TDC
- Easy to use — allows 1-man operation
- Hardened pin resists bending

Item	Description
4	Spring (part of timing pin)
5	Spring (part of timing pin)

Item	Part Number	Description
1	208-9388	Adapter
2	136-4632	Timing Pin
3	208-9387	Pin

## 268-1966 Timing Adapter Pin

### Essential Tool

Model: C6.6 Engines

Warranty: None

Part Number	Description
268-1966	Timing Adapter Pin

- Allows use of a timing pin



## 364-9107 Fuel Pump Locking Pin

Model Usage: C7.1, C6.6, C4.4

Warranty: Six Months

- Used to lock the fuel injection pump in the correct timing position
- Engages into rear of pump drive gear

Part Number	Description
364-9107	Fuel Pump Locking Pin

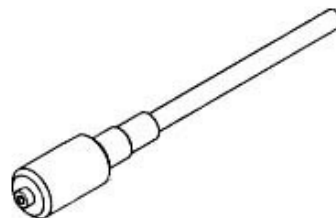

## 9U-6188 Timing Fixture Group

Model: 3054 and 3056 Engines

Warranty: Six Months

- Four separate tools used in combination to check accuracy of timing mark location on fuel injection pump or engine
- Needed to determine location of timing mark on engine if front cover is replaced

### Reference

SEN95547, Service Module in SEN95555 Service Manual

Item	Part Number	Description
--	9U-6188	Timing Fixture Group
1	9U-6189	Drive Adapter
2	9U-6190	Gear Adapter
3	9U-6192	Timing Fixture
4	9U-6191	Pointer

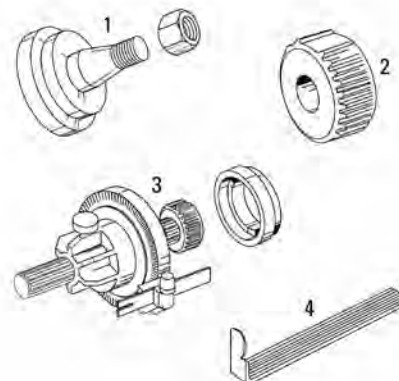

## 338-1054 Pump Timing Tool Group

### Essential Tool

Model: C6.6 Engines

Warranty: Six Months

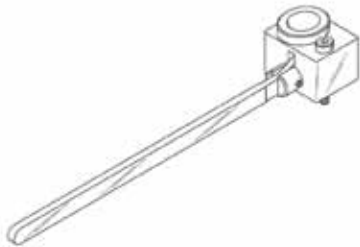

- Used to set timing of common rail fuel pump
- Required for installation to ensure proper operation of fuel pump

Part Number	Description
338-1054	Pump Timing Tool Group

## 157-3719 Fuel Spanner

Model: 3054 and 3056 Engines with Bosch Fuel Pumps

Warranty: Six Months

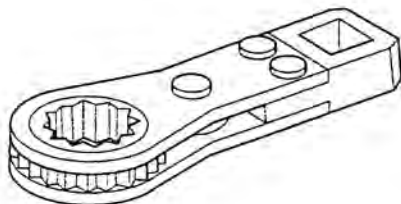

- Used to remove and install Bosch fuel injection pumps
- Built-in ratchet mechanism reduces removal/installation time
- Square drive: 3/8 inch
- Socket size: 13 mm, 12-point

Part Number	Description
157-3719	Fuel Spanner

## 192-3331 Timing Gauge

Model: 3056 Engines with Bosch Pumps

Warranty: Six Months

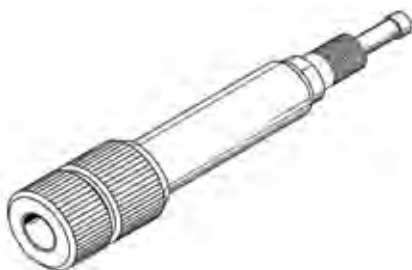

- Replaces discontinued 136-3113 Timing Gauge
- Used to hold dial indicator while checking injection pump timing on engines with Bosch EPVE fuel pump

Part Number	Description
192-3331	Timing Gauge

## 299-9126 Crankshaft Turning Group

### Essential Tool

Model: C4.2, C6.4, 3054, and 3096 Engines

Warranty: Six Months

Part Number	Description
299-9126	Crankshaft Turning Group

- Used to rotate engine crankshaft
- Used with 1/2 inch drive
- Designed with internal bearings for smooth rotation
- Bolts to access hole in flywheel housing

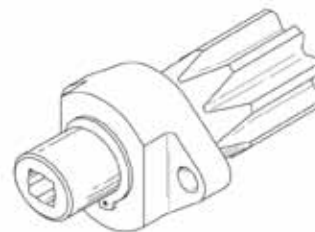

## 285-5989 Engine Turning Group

Model: 3516, 3520, and 3524 Large Mining Truck Engines

Warranty: Six Months

Part Number	Description
285-5989	Engine Turning Group

- Used to rotate engine crankshaft
- Used with 1 inch socket
- Heavy-duty design uses two needle bearings for smoother rotation
- Bolts to access hole in flywheel housing

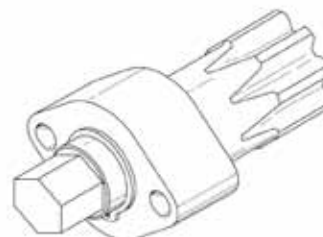

## 329-3831 Barring Group

Model: 3500, 3600, and C175 Engines

Warranty: Six Months

- Used to rotate engine during valve setting and timing procedures
- Used with shop air supply and dealer supplied connectors
- Makes engine rotation much easier and enables one-person operation
- Rugged design provides maximum durability and dependability
- 620 kPa (90 psi) air pressure produces more than 203 N·m (150 ft·lb) of torque
- Reversible-vane, air motor provides precise control in both clockwise and counterclockwise directions
- Incorporates pull pin locking device that engages/disengages barring motor
- Air supply and lock-out valves prohibit unintentional tool operation
- Dual pendant levers control direction (CW/CCW) and speed (pressing lever farther down increases rotation speed)
- Opposing male/female disconnects between air motor and control pendant for easy assembly and to ensure consistent directional control (rotation)
- Control pendant group and air motor group disconnects can be coupled together to provide air line contamination control when tooling is not assembled
- Depending on engine, use access cover or remove starter to install barring tool
- Air motor mounting flange can be positioned through 360 degrees of rotation for different applications
- 328-2307 Muffler offered as serviceable part
- 334-3258 Service Kit available for air motor rebuild

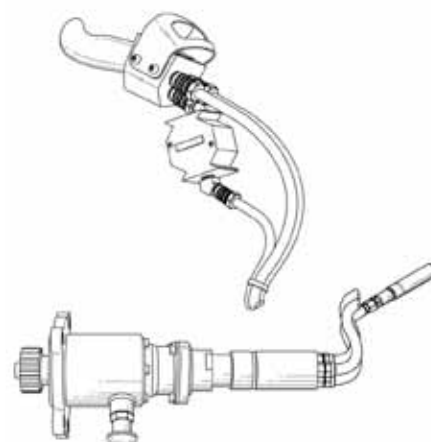

(Continued)

# Fuel System Repair and Adjust

## 329-3831 Barring Group (Continued)

Model: 3500, 3600, and C175 Engines

Warranty: Six Months

Part Number	Description
329-3831	Barring Group
Service/Repair Parts	
328-2307	Muffler
334-3258	Service Kit

## 279-3473 Barring Device

Model: C175 Engines

Warranty: Six Months



- Used to manually rotate crankshaft on C175 Engine
- Used with M34 Socket
- Bolts to starter access hole in flywheel housing

Part Number	Description
279-3473	Barring Device

## Tools for Rotating Crankshaft

Model: C15, C16, 3400, 3508, 3512 Engines and 5.4 inch Bore Engine

Warranty: Six Months

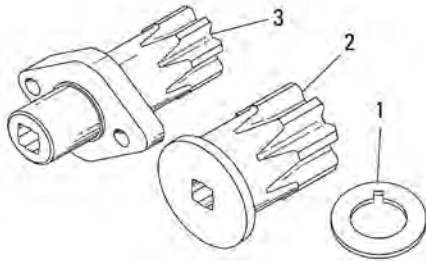

Item	Part Number	Description	Use
1	9S-9114	Spacer	Position 1P-7410 Timing Plate on discontinued 8S-2346 Shaft Assembly when setting lifters off engine
2	9S-9082	Turning Tool, 1/2 in drive	Rotate crankshaft
3	238-9586	Turning Tool, 1/2 in drive	Contains internal needle bearings; bolts to flywheel housing for easier rotation of crankshaft

## Tools for Rotating Crankshaft

Model: 3114, 3116 and 3126 Engines

Warranty: Six Months

- Used to rotate crankshaft (makes setting valves and engine timing procedures easier)
- Used with 5P-7305 Engine Turning Gear and 1/2 inch square drive ratchet
- Fastens to starter mounting hole using starter mounting bolts
- Rotate gear shaft housing assembly until 5P-7305 Engine Turning Gear engages flywheel gear before tightening starter mounting bolts

(Continued)



## Tools for Rotating Crankshaft (Continued)

Model: 3114, 3116 and 3126 Engines

Warranty: Six Months



Part Number	Description	Size
<b>Measure dimension X on starter housing to determine which part to use</b>		
9U-6943	Shaft Housing Assembly	146 mm (5.75 in)
9U-7336	Shaft Housing Assembly	127 mm (5.00 in)
5P-7305	Engine Turning Gear	6/8 and 8/10 pitch

## 9U-6198 Crankshaft Turning Tool

Model: 3054 and 3056 Engines

Warranty: Six Months

Part Number	Description
9U-6198	Crankshaft Turning Tool

- Used to rotate crankshafts (connects directly to front of crankshafts)
- Has 1/2 inch drive in center to connect ratchet or breaker bar
- Dimensions: 50 x 140 mm (2.0 x 5.5 in)

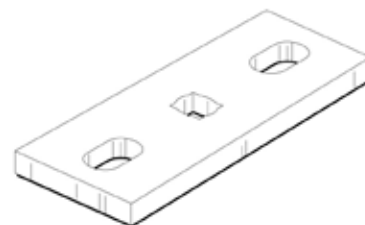

### Reference

SENR5555, Service Manual

## 208-0888 Engine Turning Tool

### Essential Tool

Model: 3176C and C-9 Engines

Warranty: Six Months

Part Number	Description
208-0888	Engine Turning Tool

- Used to turn crankshaft in engines with rear PTO flywheel housing (engages forward spline of upper PTO gear)
- Used in applications where no flywheel turning tool access is provided
- Heat-treated for added durability
- To install: remove cover plate or hydraulic pump as needed

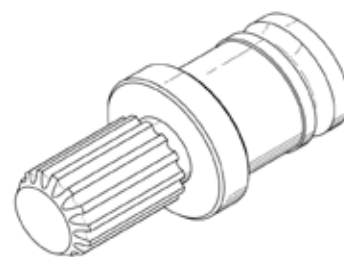

Square drive	3/4 in
Spline	14-tooth

## 178-8615 Socket

Model: 3114, 3116, 3126 MUI, HEUI, and 3126B Engines  
 Warranty: Six Months

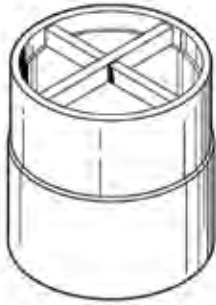

- Used to turn engine crankshaft by hand
- Socket crossbars engage all four bolt heads in front pulley hub
- Prevents over-tightening or loosening of a single bolt when it used to turn crankshaft clockwise or counterclockwise
- Square drive: 3/4 inch
- Overall length: 90 mm (3.5 in)

Part Number	Description
178-8615	Socket

## 350-7549 Socket Assembly (C9.3 Engine)

### Essential Tool

Model Usage: All C9.3 Engines  
 Warranty: Six Months

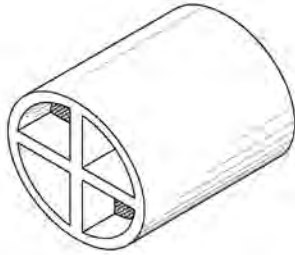

- Used to rotate crankshaft by hand
- Used with 3/4 inch square drive ratchet
- Socket cross-bars engage four front pulley hub bolts eliminating need for removal to attach turning tool

Part Number	Description	Size
350-7549	Socket Assembly (C9.3 Engine)	Overall diameter: 79 mm (3.11 in) x 87 mm (3.43 in) long

## 5P-7306 Gear Shaft Housing Assembly

### 5P-7305 Engine Turning Gear

Model: Cat® Engines  
 Warranty: Six Months

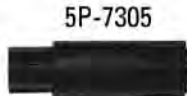

- Makes engine rotation much easier for valve setting and timing procedures, especially on engines with no compression release
- Any engine that will accept standard short and long nose electric starters can be rotated
- Pinion gear has 6/8 pitch gear on one end and 8/10 pitch on other
- Both ends of pinion have 1/2 inch square drive hole to accommodate standard ratchet

Part Number	Description
5P-7305	Engine Turning Gear
5P-7306	Gear Shaft Housing Assembly

## 5F-2807 Cap

## 2F-2990 Plug

Model: D5B, D6D, D9N, IT28, 943, 953, 963, 973

Warranty: Six Months

Part Number	Description
2F-2990	Plug
5F-2807	Cap

- Used to protect fuel pumps (cap) and lines (plug) when removing them from engine



## 6V-4089 Reamer Assembly

Model: 1100, 3100, 3200 and 330 Series Direct Injection Engines

Warranty: Six Months

Part Number	Description
6V-4089	Reamer Assembly

- Removes carbon deposits from bores of pencil-type fuel nozzles



## 5B-1401 Fuel Injection Valve Orifice Cleaning Tool Group

Model: Cat® Engines

Warranty: Six Months

- Used to remove carbon from orifice in nozzle end of flat seat-type fuel injection valves
- Chuck has hollow handle to store drills
- Do not use these tools to clean capsule-type valves

Item	Part Number	Description	Size
1	5B-1254	Chuck	--
2	7F-1522	Drill, 0.711 mm (0.028 in)	--
2	6H-8639	Drill, 0.813 mm (0.032 in)	--
--	5B-1401	Fuel Injection Valve Orifice Cleaning Tool Group	--
2	5B-2177	Drill	0.5 mm (0.0197 in)
2	5B-2178	Drill	0.610 mm (0.024 in)
2	7B-5724	Drill	0.445 mm (0.0175 in)

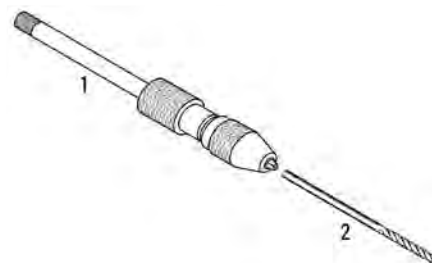

## 8S-2245 Cleaning Tool Group

Model: 1100, 3100, 3208

Warranty: Six Months



- Used to properly service pencil-type injection nozzles used in 1100 and 3100 Series and 3208 Engines

### Reference

SEHS7292

Item	Description
4	Pad

Item	Part Number	Description	Size
1	8S-2262	Case Assembly	--
2	8S-2256	Vise Assembly	--
3	5P-0958	Retractor Assembly	--
5	8S-2246	Wire Assembly	0.20 mm (0.008 in)
6	8S-2247	Wire Assembly	0.28 mm (0.011 in)
7	5P-4813	Socket	--
8	8S-2259	Lapping Compound	--
9	8S-2257	Loupe	--
10	6V-4979	Carbon Stop Seal Tool	--
11	2P-5487	Adapter	--
12	8S-2250	Holding Tool	--
13	6V-9124	Screwdriver	--
14	8S-2254	Retractor Assembly	--
15	8S-2255	Scraper	--
16	8S-2251	Drill	--
17	8S-2258	Brass Wire Brush	--
18	8S-2260	Honing Stone	--
--	8S-2245	Cleaning Tool Group	--

## 5P-6229 Extractor

Model: 3400 Series Direct Injection Engine

Warranty: Six Months



- Used to remove fuel nozzle adapter body on 3400 Series Direct Injection Engines and most other engines with precombustion chambers

Part Number	Description
5P-6229	Extractor

## Fuel Injection Valve Nut Removal Tools

Model: Cat® Engines  
Warranty: Six Months

- Used for fuel injection valve nut removal on early engines

Item	Description	Size
2	Wrench	17/8 in hex

Item	Part Number	Description	Size
3	4B-9918	Handle	--
1	9B-2029	Wrench	1 3/4 in hex

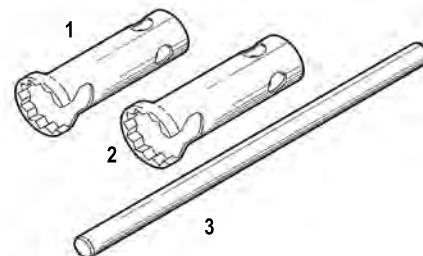

## FT1533 Nozzle Adapter

Model: Cat® Engines  
Warranty: None

- Recommended for use with 1P-0074 Slide Hammer for nozzles that are difficult to remove

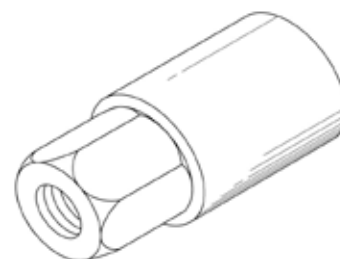

## 6V-4061 Nozzle Puller Group

Model: D5B, D6D, 225B, 225B-3208, 3208, 518  
Warranty: Six Months

Item	Part Number	Description
1	1B-4206	Nut
2	2S-5658	Washer
3 <sup>1</sup>	6V-4153	Plate
4 <sup>1</sup>	6V-4152	Screw
5	6V-4150	Leg
6	6V-4149	Jaw
7	6V-4151	Leg
--	6V-4061	Nozzle Puller Group

- 6V-4061 Nozzle Puller Group used to remove direct injection fuel nozzles from 1100, 3100, 3200 and 3300 Series DI Engines



<sup>1</sup>Also part of 6V-4061 Puller Group

## 6V-4054 Nozzle Puller Group

Model: D5B, D6D, 225B, 225B-3208, 3208, 518

Warranty: Six Months



- 6V-4054 Puller Group used with 6V-4061 Group to remove 7N-0449 Nozzles in 3300 Series DI Engines (all parts of 6V-4061 Puller Group, except 6V-4153 Plate, needed)

Item	Part Number	Description
1	0S-1618	Bolt
--	6V-4054	Nozzle Puller Group

## FT1663 Fuel Nozzle Holder

Model: Cat® Engines

Warranty: None



- Holds and identifies up to 8 fuel injection nozzles
- Fabricated from 9L-7276 Cover

## 6V-6980 Nozzle Puller Group

Model: 3300

Warranty: Six Months



- Replaces discontinued 6V-3129 Puller
- Used for removing 8N-7003 and 8N-7005 Nozzles used in 3300 Series Engines; can also be used for removal of discontinued 8N-7001 and 8N-7002 Nozzles
- Required because carbon build-up around nozzle stems prevent nozzles from being removed by hand

### NOTE:

The 6V-6980 Puller Group should only be used when less than 150 pound-inches torque is required to pull the nozzle. The nozzle stem will bend or break if more than 150 pound-inches torque is applied with the 6V-6980 Puller. For nozzles that are extremely difficult to remove, the FT1533 Adapter and 1P-0074 Slide Hammer are still recommended. When using these tools, it is often necessary to remove various engine components.

Item <sup>1</sup>	Part Number	Description
--	6V-6980	Nozzle Puller Group
1	6V-6197	Screw
2	6V-6198	Clip
3	6V-6199	Button
4 <sup>2</sup>	6V-6130	Puller

<sup>1</sup> Item 4: 6V-6130 Puller (not serviced)

<sup>2</sup> Not serviced

## 6V-6976 Puller Group

Model: 3204

Warranty: Six Months

Item	Part Number	Description
1	1B-4206	Nut
2 <sup>1</sup>	2S-5657	Washer
3 <sup>1</sup>	6V-4153	Plate
4 <sup>1</sup>	6V-4152	Screw
5	6V-6979	Leg
6	6V-6978	Head
7	6V-6977	Leg
8	1D-4716	Nut
--	6V-6976	Nozzle Puller Group

- Used to remove discontinued 1W-3996 Direct Injection Fuel Nozzles on 3204 Engines; nozzles tend to stick in their bores due to carbon deposits, etc.

**NOTE:**

As indicated in the parts list, several parts of the 6V-6976 Puller Group are also used in the existing 6V-4061 Nozzle Puller Group. If the dealer already has the 6V-4061 Group, only the last 4 parts (items 5, 6, 7 and 8) are needed to assemble the 6V-6976 Group.



<sup>1</sup> Also part of 6V-4061 Puller Group

## 6V-7020 Nozzle Puller Group

Model: Cat® Engines

Warranty: Six Months

- Combines all components of 5 nozzle puller groups listed below without duplicating commonly-used components
- Also included are various maintenance items, such as 6V-4979 Carbon Stop Seal Tool, 25 extra carbon stop seals and 6V-4089 Reamer for carbon removal; socket, extension and handle included for removal of 5/16 inch-12 point hold down screws used on some nozzle clamps

**Reference**

SEHS8094, Special Instruction

Nozzle Puller Group	Engine Used On	Nozzle Part Number
6V-6981	3406	8N-7006
6V-6980	3300 Series	8N-7005, 8N-7003
6V-6976	3204	--
6V-4061	1100, 3100 and 3200 Series	9N-2366, 9N-3299, 1W-5829, 9L-6969, 9N-3299
6V-4054	3300 Series	7N-0449



Part Number	Description	Quantity
6V-7020	Nozzle Puller Group	--
<b>Service/Repair Parts</b>		
5P-4199	Handle	1
5P-7276	Container	1
6V-3072	Case - Plastic, NEEG2574 Group Decal on lid (9U-7402 Group)	1
6V-4054	Nozzle Puller Group	1
6V-4089	Reamer Assembly	1
6V-4149	Jaw	1
6V-4150	Leg	1

Part Number	Description	Quantity
<b>Service/Repair Parts (Continued)</b>		
6V-4151	Leg	1
6V-4979	Carbon Stop Seal Tool	1
6V-6976	Nozzle Puller Group	1
6V-6980	Nozzle Puller Group	1
6V-6982	Sleeve Assembly	1
6V-6983	Adapter	1
6V-7031	Block	1
9L-9098	Carbon Stop Seal	25
9S-1715	Socket	1
9S-1721	Extension	1

## 6V-6981 Nozzle Puller Group

Model: 3406

Warranty: Six Months



- Used for removal of 8N-7006 Direct Injection Fuel Nozzles from 3406 Engines
- Uses several parts from earlier 6V-4061 Nozzle Puller Group

Item	Part Number	Description
1	1B-4206	Nut
2	2S-5658	Washer
3	6V-4152	Screw
4 <sup>1</sup>	6V-6982	Sleeve As- sembly
5 <sup>1</sup>	6V-6983	Adapter
--	6V-6981	Nozzle Puller Group

<sup>1</sup>These parts are needed to make the 6V-6981 Nozzle Puller Group from the earlier 6V-4061 Nozzle Puller Group.

## 9U-6278 Injector Puller Connector

Model: 3054, 3056, 3064, and 3066 Engines

Warranty: Six Months

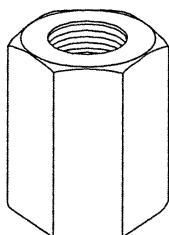

- Used to remove stuck injector nozzles due to carbon deposit build-up in bore
- Used with 1U-7600 Puller Group
- 1/2 - 20 thread (female) on one end and M12 x 1.5 thread (female) on other end

Part Number	Description
9U-6278	Injector Puller Con- nector

## Tools for 3406B Engine Fuel Nozzle and Fuel Nozzle Adapter

Model: 3406B

Warranty: Six Months



- Smaller tools required to remove and install cylinder heads on 3406B Engines, which were redesigned with smaller diameter fuel injection nozzle adapters

Item	Part Number	Description
1	1B-4206	Nut
2	8T-3199	Screw
3	6V-6983	Adapter
4	8T-3198	Sleeve As- sembly



## 4C-8175 Nozzle Puller Assembly

Model: 3306 Engine

Warranty: Six Months

Part Number	Description
4C-8175	Nozzle Puller Assembly

- Used to remove 104-9450 Direct Injection Fuel Nozzle Assembly
- Required for nozzle removal (carbon build-up around nozzle stems prevents removal by hand)
- Using specialized puller makes nozzle removal faster, easier, and helps prevent damage
- As of June 1, 1994 the 104-9450 Fuel Injection Nozzle is used only in the European market



4C-8175

## 134-2570 Nozzle Retainer Spanner Wrench

Model: 3406B, 3406C, 3408, 3408B, and 3412 Engines with P and L Fuel Systems

Warranty: Six Months

- Replaces discontinued 8T-3139 Spanner Wrench and 9U-5840 Spanner Wrench
- Used to remove and install 7W-2315 Fuel Injection Nozzle Retainer
- Provides additional clearance for 3406B and 3406C Engines equipped with Jacobs Engine Brake
- Made from SAE 4140 steel and heat-treated for long tool life

Hex size	14.28 mm ( 9/16 in)
Overall height	20.5 mm (0.81 in)
Overall diameter	41.0 mm (1.61 in)
Distance between pins	28.5 mm (1.12 in)

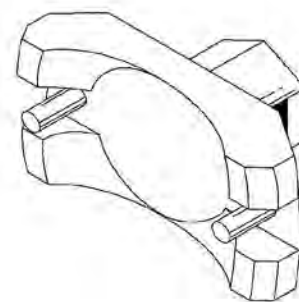

Part Number	Description
134-2570	Nozzle Retainer Spanner Wrench

## 1U-9725 Wrench

Model: See below

Warranty: Six Months

- Used on following engines to remove and replace nozzle adapters
- Larger and stronger to eliminate breakage when removing tight adapters
- Works on both 7W-1645 (old style) and 7W-5435 (new style) Nozzle Adapters
- Has 1/2 inch square drive for normal usage, and 28.57 mm (1 1/8 in) hex so larger drive socket can be used when removing tight adapters

Engine	Serial No.
3406B	All
3408	S/N 78Z-1277-up
	S/N 67U-11092-up (DI only)
3412	S/N 81Z-4579-up
	S/N 38S-13223-up
	S/N 60M-2477-up

Part Number	Description
1U-9725	Wrench



## 9U-7227 Injector Height Setting Gauge

### 187-0482 Spacer Sleeve

Model: 3406E Engines

Warranty: Six Months

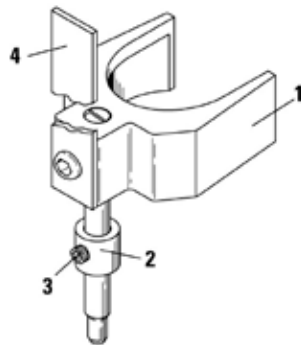

#### 9U-7227 Injector Height Setting Gauge

- Used to adjust injector Prestroke
- Leaves both hands free to make adjustments

#### 187-0482 Spacer Sleeve

- Used to help prevent improper injector height settings
- Used with 9U-7227 Injector Height Gauge with a straight indicator pin (spacer sleeve can be ordered separately)
- Sleeve rests against injector spring to keep gauge square on spring retainer
- Earlier gauges with a support flare machined onto the indicator pin do not need this spacer
- All new gauges include a spacer sleeve

#### References

SENR5580, Service Manual

SENR6421, Service Manual Module, Disassembly and Assembly 3406E Engines

Item	Part Number	Description
1	9U-7227	Injector Height Gauge Assembly
2	187-0482	Spacer Sleeve
3	4L-5966	Setscrew
4	1U-9084	Flag

## 1U-8780 Nozzle Puller Group

Model: 3200, 3300

Warranty: Six Months



- Works to pull all 7000 Series Fuel Nozzles on 3200 and 3300 Series Engines; short enough to use on rear cylinders on 3208 Engines in highway trucks
- Strong enough to pull stuck nozzles on 3300 Series Engines
- Replaces two nozzle pullers: 6V-6980 Nozzle Puller Group for 3300 Series Engines and 6V-6976 Nozzle Puller Group for 3204 Engines
- Has two adapters, one with full clamp for 3300 Series Engines and one with half clamp for 3200 Series Engines

Part Number	Description
1U-8780	Nozzle Puller Group

## 6V-7025 Guide

Model: 3406

Warranty: Six Months



- Replaces discontinued 5P-4755 Guide
- Used to properly install 5P-2060 Seal onto 4N-3761 Direct Injection Capsule Valve Adapter on 3406 Engines

Part Number	Description
6V-7025	Guide

## 9U-5127 Tool Group, 3408 PEEC, and 3412 PEEC

Model: 3408 and 3412 PEEC Engine

Warranty: Six Months

- Replaces discontinued 4C-9579 Tool Group
- Used to test and adjust fuel pump timing on 3408 and 3412 PEEC Engines
- Increased accuracy
- On-engine field adjustments expand capability of field service mechanics
- Increases service revenue opportunities
- Durable, high quality design — convenient case protects tool investment
- 90 mm (3.54 in) long timing pin
- Two 89 mm (3.50 in) long rack zero pins
- Modified 19.05 mm ( 3/4 in) crowsfoot with 3/8 inch drive
- Slotted 1 5/16 inch socket with 1/2 inch drive
- Solenoid spanner wrench with 3/8 inch square drive
- 6V-2112 Pin for Haliburton Engines

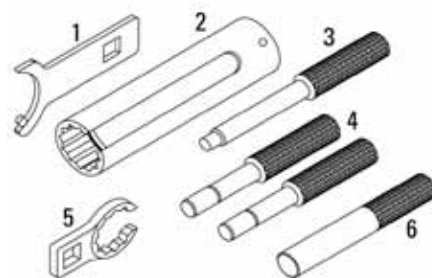

Item	Part Number	Description
1	9U-5120	Spanner Wrench
2	136-3124	Socket-Sensor (rack)
3	6V-2112	Pin
3 and 6	6V-4186	Pin - Fuel Pump Timing
4	4C-9581	Pin
5	4C-9582	Crowfoot Wrench, 19.05 mm ( 3/4 in)
--	9U-5127	Tool Group, 3408 PEEC, and 3412 PEEC
<b>Not Shown</b>		
4	6V-3073	Case - Plastic
--	9U-5128	Foam

## 9U-5219 Tool Group 3406 PEEC Engines

Model: 3406B PEEC Engine

Warranty: Six Months

- Replaces discontinued 1U-5540 Tool Group (to update former 1U-5540, order 9U-5103 Slotted Socket, 9U-5225 Foam Block, and NEEG2516 Decal
- Used to set clearance dimension between engine speed sensor and 4W-2485 Slotted Retainer (pulse wheel)
- Establish zero rack position, necessary before discontinued 8T-8697 ECAP can be used to calibrate rack position sensor without breaking governor seals
- Remove and install 6T-9675 Solenoid (fuel shutoff)
- Set timing position sensor, necessary before 8T-5282 DDT and/or discontinued 8T-8697 ECAP can be used to calibrate timing position sensor
- Remove and install water temperature sensor



### Reference

SEHS8746, Special Instruction

Item (not shown)	Description
NEEG2516	Decal

(Continued)

# Fuel System Repair and Adjust

## 9U-5219 Tool Group 3406 PEEC Engines (Continued)

Model: 3406B PEEC Engine

Warranty: Six Months

Engine Tools

Item	Part Number	Description	Size
1	8T-9198	Rack Indicator Bracket Assembly	--
2	5P-4814	Collet As - Clamp	--
3	9U-5120	Spanner Wrench	--
4	6V-4186	Pin - Fuel Pump Timing	90 mm (3.54 in)
5	1U-5426	Zero Rack Compressor Assembly	--
5	6D-3982	Nut	--
5	7F-2359	Spring	--
5	9S-8903	Point	2.4 mm (0.094 in) <sup>1</sup>
6	9U-5103	Slotted Socket	--

Item	Part Number	Description	Size
7	5P-0326	Crowfoot Wrench	19.05 mm ( 3/4 in)
8	1U-5536	Crowfoot Wrench	33.33 mm (1 5/16 in)
9	1U-5425	Timing Gauge Assembly	--
--	9U-5219	Tool Group 3406 PEEC Engines	--
<b>Not shown</b>			
1	6V-3072	Case - Plastic, NEEG2574 Group Decal on lid (9U-7402 Group)	--
--	9U-5225	Foam Block	--

<sup>1</sup> 12.7 mm (0.5 in) diameter flat face with a bevel to 9.7 mm (0.38 in) diameter

## 9U-5292 Rack Preload Assembly (3400 PEEC)

Model: 3406, 3408, and 3412 Series NSFS (PEEC) Engines with Fuel Injection Pump and Governor Group

Warranty: Six Months

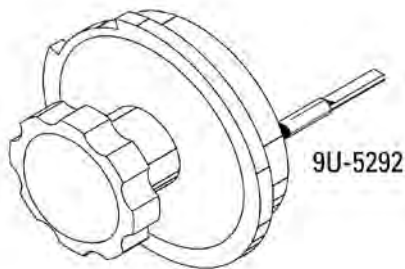

- Used to set the PEEC injection pump rack position without an electronic control system

### 9U-5292 Rack Preload Assembly

- Used to hold pressure against (preload) rack in plus direction
- Fits in place of pumps electronic control unit (BTM)
- Fluted knob provides easy adjustment
- Outside diameter: 82.6 mm (3.25 in)
- Knob: 1V-5044

Part Number	Description
9U-5292	Rack Pre-load Assembly

## 9U-5295 Rack Position Group (3400 PEEC)

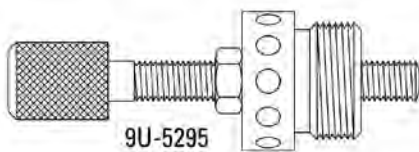

### 9U-5295 Rack Positioning Group

- Used to limit travel of rack and make precision rack adjustments
- Fits in place of the rack shut-off solenoid
- Knurled surfaces provide better grip while adjusting rack position
- Parts are serviced individually

### References

NEHS0625, Tool Operating Manual

NEHS0639, Tool Operating Manual

Part Number	Description	Size
9U-5295	Rack Positioning Assembly	--
<b>Rack Positioning Group Consists of:</b>		
9U-5294	Threaded Bushing	--
9U-5293	Rack Adjusting Screw	1 3/16 - 12
3S-2713	Full Hardened Nut	--

## 8T-5160 Gas Regulator Setting Tool Group

Model: All gas engines with Fisher Gas Regulators (Use FT2613 for gas engines with the discontinued 7E-3407 Sprague Gas Regulator)

Warranty: Six Months

- Used to adjust gas line pressure regulator on entire current and non-current lines of spark ignition engines
- Can service engines equipped with both smaller regulator used on 3304 and 3306 and 2 of the larger regulators used on larger engines
- Allows adjustment of gas regulator spring with no leakage at air side of regulator; air leakage during adjustment causes incorrect settings

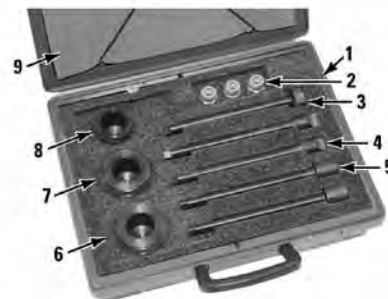

Item	Part Number	Description	Quantity
1	6V-3072	Case - Plastic, NEEG2574 Group Decal on lid (9U-7402 Group)	--
2	8T-5149	Fitting	3
3	8T-5164	Tool	--
4	8T-5163	Tool	2
5	8T-5165	Tool	2
6	8T-5159	Foam Block	--
7	8T-5162	Adapter	2
7	6L-7141	Gasket	2
8	3H-8012	Gasket	--
8	8T-5161	Adapter	--
9	6V-6105	Block	--
--	8T-5160	Gas Regulator Setting Tool Group	--

### Assembled Setting Tool

Model: All gas engines with Fisher Gas Regulators (Use FT2613 for gas engines with the discontinued 7E-3407 Sprague Gas Regulator)

Warranty: Six Months

#### Application Procedure

1. Select appropriate tool, adapter and gasket for regulator being set and assemble using 8T-5149 Fitting
2. To install, remove gas regulator cap and thread adapter into regulator in place of cap; push tool shaft down until it engages adjustment screw or nut and tighten fitting just enough to seal off any air leaks around shaft



Assembled Setting Tool

(Continued)

## Assembled Setting Tool (Continued)

Model: All gas engines with Fisher Gas Regulators (Use FT2613 for gas engines with the discontinued 7E-3407 Sprague Gas Regulator)

Warranty: Six Months

3304, 3306 Positive Pressure Regulator	1 each	Adapter
		Tool
		8T-5149 Fitting
		Gasket
3304, 3306 Vacuum Regulator	1 each	Adapter
		Tool
		8T-5149 Fitting
		Gasket
3400, 3500 Positive Pressure Regulator	1 each	Adapter
		Tool
		8T-5149 Fitting
		Gasket
3400, 3500 Vacuum Regulator	1 each	Adapter
		Tool
		8T-5149 Fitting
		Gasket
379, 398, 399 Positive Pressure Regulator	2 each	Adapters
		Tools
		8T-5149 Fittings
		Gaskets
379, 398, 399 Vacuum Regulator	2 each	Adapters
		Tools
		8T-5149 Fittings
		Gaskets

## FT2613 Gas Regulator Cap Assembly

Model: All Models with discontinued 7E-3407 Gas Regulators

Warranty: None

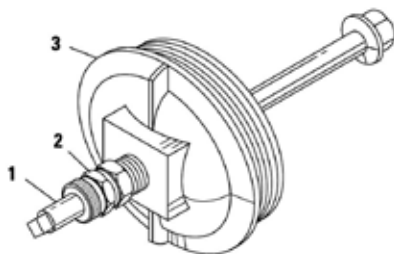

- Used to adjust gas line pressure on discontinued 7E-3407 Gas Regulators
- Adjust regulator while engine is running
- Eliminates costly engine downtime
- Allows adjustment of regulator with no leakage

### Application Procedure

1. To install, push 155-3062 through FT2613 and 8T-5149. Position hex/washer end into regulator and tighten cap. Make sure 123-5974 O-ring is in place.
2. Tighten fitting around adjusting tool to prevent leakage, but loose enough to adjust regulator.
3. Adjust regulator and remove tools when finished.

Item	Part Number	Description
3	FT2613	Cap Assembly

(Continued)

## FT2613 Gas Regulator Cap Assembly (Continued)

Model: All Models with discontinued 7E-3407 Gas Regulators

Warranty: None

Item	Part Number	Description
<b>Gas Regulator Adjusting Tool</b>		
1	155-3062	Regulator Adjusting Tool
2	8T-5149	Fitting
3	123-5974	O-ring

## Fuel Injection Pump Extractors

Model: 1100, 3100, 3200

Warranty: Six Months

- Use the extractor and wrenches to remove and install fuel injection pumps and retaining bushings

### Buttress Taps

- Bottoming
- For cleaning threads on 3300 NSFS and 3400 NSFS fuel system pumps



Size	Threads Per Inch	Part Number	Pitch Diameter
1.375 in	12	1U-6725	33.746 ± 0.090 mm (1.329 ± 0.004 in)
1.750 in	12	1U-6726	43.276 ± 0.090 mm (1.704 ± 0.004 in)

Item	Part Number	Description	Use
1	8S-2244	Extractor	--
2	8S-2243	Wrench	With 8S-2244 Extractor to remove and install fuel injection pumps on 1100 and 3100 Series Engines and engines with Sleeve Metering Fuel Systems
3	8T-5287	Wrench	With 8S-2244 Extractor to remove and install fuel injection pumps on engines with compact fuel systems; replaces discontinued 8S-4613 Wrench
4	5P-1668	Wrench, 3/8 in drive	Remove and install fuel pump retaining bushings where space does not permit use of 8S-2243 Wrench on 1100, 3100 and 3200 Series Engines

## 6V-7050 Compressor Group

Model: 3406

Warranty: Six Months

- Used for servicing fuel pump plunger and barrel assemblies on 3406 Engines with New Scroll Fuel System
- Needed to compress heavier pump lifter springs on these engines when plunger and barrel assemblies are removed and installed

### Reference

SMHS8278, Special Instruction



Item	Part Number	Description
1	2N-3476	Screw (4)
2	6V-7015	Clamp Assembly
3	5M-7418	Nut

(Continued)

# Fuel System Repair and Adjust

## 6V-7050 Compressor Group (Continued)

Model: 3406

Warranty: Six Months

Item	Part Number	Description
4	4B-1228	Screw
5	4B-2046	Nut
--	6V-7050	Compressor Group
<b>Not shown<sup>1</sup></b>		
--	148-5677	Block
--	148-5675	Case

<sup>1</sup> Also not shown: Block

## 6V-4180 Off-Engine Lifter Setting Tool Group

Model: All Engines with Forged Body or Compact Fuel Systems

Warranty: Six Months

- Replaces 5P-6600 Tool Group
- Includes lifter setting tools for all current engines, including 3400 Series Engines
- Also included are shaft assemblies which clamp positively to camshafts, eliminating movement between camshaft and degree wheel
- Tools required for individual engines are listed in the application chart below
- Additional tools needed, but not included, with 6V-4180 Group are also illustrated



6V-4180 Off-Engine Lifter Setting Tool Group		
Item	Part Number	Description
1	6V-4181	Tool Holder Block
1	9S-8105	Liner
1	9S-6332	Box Assembly
--	6V-4180	Off-Engine Lifter Setting Tool Group



## Additional Tools Needed But Not Included in 6V-4180 Group

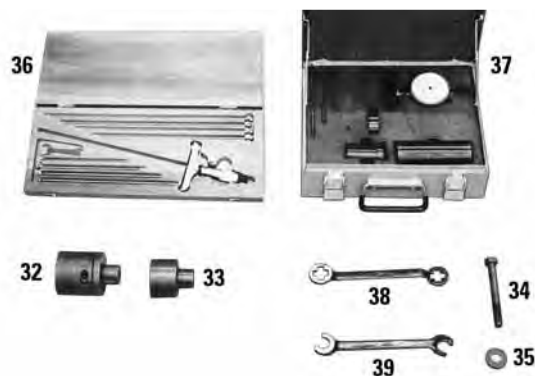

Engine Tools

Additional Tools Needed But Not Included in 6V-4180 Group		
Item	Part Number	Description
32	5P-6570	Shaft
33	8S-2272	Shaft Assembly
34	1B-3680	Bolt
35	3F-1417	Washer
36	6V-2012	Gauge Group
37	6V-7926	Indicator Group
38	9M-4567	Wrench
39	9M-4568	Wrench

## Application Charts for 6V-4180 Tool Group

Components of 6V-4180 Tool Group (Fig. 1)								
Item	Part Number	Description	D311, D312, D315, D318, D339, D342, D364, D375, D386, D397, D468, D3400, D4400, D4600, D6100, D6600, D7700, D8800, D11000, D13000, D17000	D326, D337, D343, 619C, 824A, 1693	D346, D348, D349	D349	D379, D398, D399	641, 650, 651, 657, 660, 666
<b>Forged Body Fuel System</b>								
2	5P-6574	Shaft	--	--	1	--	--	--
3	5P-6564	Shaft	--	--	--	--	1	--
5	5P-6568	Shaft	--	--	--	1	--	--
9	2S-6160	Washer	1	1	1	--	1	1
11	0S-1594	Bolt	1	--	1	1	1	--
12	0S-0509	Bolt (3/8 - 16)	1	1	1	--	1	--
13	0S-1617	Bolt	--	1	--	--	--	--
18	1P-7415	Pointer	1	--	1	--	--	--
19	5P-6572	Shaft	--	1	--	--	--	--
31	1P-7410	Degree Wheel	1	1	1	1	1	1
38 <sup>1</sup>	9M-4567	Wrench	1	--	--	1	1	--
39	9M-4568	Wrench	1	1	--	1	1	1

(Continued)

# Fuel System Repair and Adjust

## Application Charts for 6V-4180 Tool Group (Continued)

Engine Tools

Components of 6V-4180 Tool Group (Fig. 1)								
Item	Part Number	Description	D311, D312, D315, D318, D339, D342, D364, D375, D386, D397, D468, D3400, D4400, D4600, D6100, D6600, D7700, D8800, D11000, D13000, D17000	D326, D337, D343, 619C, 824A, 1693	D346, D348, D349	D349	D379, D398, D399	641, 650, 651, 657, 660, 666
<b>Additional Tools Needed But Not Included in 6V-4180 Tool Group</b>								
32	5P-6570	Shaft	--	1	--	--	--	--
36 <sup>1</sup>	6V-2012	Gauge Group	1	1	1	1	1	1
37	6V-7926	Indicator Group	1	1	1	1	1	1
38 <sup>1</sup>	9M-4567	Wrench	1	--	--	1	1	--

<sup>1</sup>Optional

### Compact Fuel System

Item	Components of 6V-4180 Tool Group (Fig.1)	D311H, D320, D330D, D333, 1670, 1673, D8, 583, 3204, 3304, 3306	D334, D343, 1674, 6193	D336, 1676	1140, 1145, 1150, 1160, 3145, 3150, 3160	3406	3408, 3412
14	Pointer				1		

Components of 6V-4180 Tool Group (Fig.1)								
Item	Part Number	Description	D311H, D320, D330D, D333, 1670, 1673, D8, 583, 3204, 3304, 3306	D334, D343, 1674, 6193	D336, 1676	1140, 1145, 1150, 1160, 3145, 3150, 3160	3406,	3408, 3412
<b>Compact Fuel System</b>								
7	5P-4158	Gauge	1	1	1	1	1	1
8	1F-1375	Bolt	--	--	2	--	--	--
9	2S-6160	Washer	1	1	1	--	1	1
10	2S-0932	Washer	--	--	--	1	--	--
11	0S-1594	Bolt	--	--	1	1	1	--
12	0S-0509	Bolt	1	1	1	--	1	--
13	0S-1517	Bolt	--	1	--	--	--	1
15	6V-6019	Pin	--	--	--	--	--	1
16	1J-6298	Bolt	--	--	--	1	--	--
17	2M-5218	Shaft	1	--	--	--	--	--
18	1P-7415	Pointer	--	--	1	--	--	--
19	5P-6572	Shaft	--	1	--	--	--	--
22	7S-5803	Shaft	--	--	1	--	--	--
23 <sup>1</sup>	6V-3035	Shaft	1	--	--	--	--	--
24 <sup>2</sup>	5P-1768	Pointer	--	--	--	--	1	1
25	9S-4446	Shaft	--	--	--	1	--	--

(Continued)

## Compact Fuel System (Continued)

Components of 6V-4180 Tool Group (Fig.1)								
Item	Part Number	Description	D311H, D320, D330D, D333, 1670, 1673, D8, 583, 3204, 3304, 3306	D334, D343, 1674, 6193	D336, 1676	1140, 1145, 1150, 1160, 3145, 3150, 3160	3406,	3408, 3412
<b>Compact Fuel System (Continued)</b>								
26	5P-3601	Adapter	--	--	--	--	--	1
27	1P-7420	Pointer	1	1	--	--	--	--
28	5P-1761	Shaft	--	--	--	--	1	--
29 <sup>3</sup>	6V-3066	Shaft	1	--	--	--	--	--
30 <sup>4</sup>	5P-0129	Sleeve	1	--	--	--	--	--
31 <sup>2</sup>	1P-7410	Plate	1	1	1	1	1	1
<b>Additional Tools Needed But Not Included in 6V-4180 Tool Group</b>								
33 <sup>5</sup>	8S-2272	Shaft	--	--	--	1	--	--
34 <sup>5</sup>	1B-3680	Bolt	--	--	--	1	--	--
35 <sup>5</sup>	3F-1417	Washer	--	--	--	1	--	--
36 <sup>6</sup>	6V-2012	Gauge Group	--	1	1	1	1	1
37	6V-7926	Indicator	--	1	1	1	1	1
--	6V-2112	Pin	--	--	--	1	1	--
--	2A-0762	Bolt	--	--	--	--	--	1

<sup>1</sup> 3204 (10X S/N)

<sup>2</sup> Early pointer groups have a discontinued 5P-6219 Dowel, 15.8 mm (0.622 in) diameter installed for 3408 and 3412 engines. Also the 7.14 mm (0.281 in) diameter hole must be increased to 8.5 mm (0.328 in) diameter for use on later 3408 and 3412 fuel pump housings.

<sup>3</sup> 3304 (9Z) and 3306 (10Z)

<sup>4</sup> 3204 (45V S/N)

<sup>5</sup> Max-Min governor only

<sup>6</sup> Optional

## 6V-7870 Fixture Group

Model: Cat® Engines

Warranty: Six Months

Item	Part No.	Description
1	4B-6060	Setscrew (2)
2	4B-2046	Nut
3	6V-7015	Clamp Assembly
4	2N-3476	Screw (4)
--	6V-7870	Fixture Group

- Designed with adjustable clamp and 5-position turret
- 1 position used for 3406B Engines with New Scroll Fuel Systems and remaining 4 positions for other engines with fuel pumps having reverse flow check valves
- 6V-7871 Repair Kit, consisting of turret and detent, also available

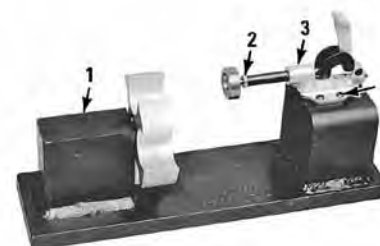

### Reference

SMHS8378, Special Instruction

## Tools for Accessory Drive Gear

Model: 3204 Vehicular Engines

Warranty: None



- 4 fabricated tools needed to loosen accessory drive gear from shaft without removing radiator on 3204 Vehicular Engines
- FT1537 Socket and FT1539 Puller used on 45V Vehicular Engines
- FT1537 Socket, FT1538 Puller and FT1540 Puller used on 10X Vehicular Engines
- 8H-8561 Adapter and 5P-8676 Extension also required

Item	Part Number	Description
1	FT1539	Puller
2	FT1540	Puller
4	FT1538	Puller
6	FT1823	Socket

Item	Part Number	Description
3	8H-8561	Adapter
5	5P-8676	Extension

## 9S-8520 Puller Group

### Discontinued — Service Parts Available

Service Parts Warranty: Six Months



Item	Part Number	Description
1	9S-8527	Bolt
2	5P-3031	Thrust Washer
3	9S-8528	Bolt Assembly
--	9S-8520	Puller Group

## FT0887 Timing Pin

Model: 1100, 3100

Warranty: None

- Used to set timing dimensions on 1100 and 3100 Series Engines
- Can be used without removing fuel lines and air inlet pipe

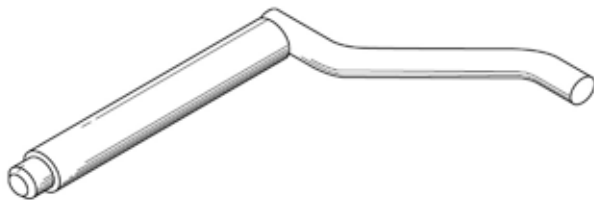

## Sockets for Special Applications

Model: 3208, 1100, D379, D398, D399

Warranty: Six Months



Item	Part Number	Description	Size	Use
1	9S-5031 <sup>1</sup>	Deep Well Socket	5/8 in, 3/8 in drive	Required for tachometer drive adapter shaft removal on 1100 and 3100 Series Engines equipped with hydraulic governors; also used for removal and tightening cap on 9L-6969 Nozzle for 3208 Engines
2	8S-2357	Deep Well Socket	9/16 in, 3/8 in drive	Required to loosen bolt which retains automatic timing advance unit to fuel injection pump camshaft on 1100 Series Engines equipped with max-min governor
3	9S-6054	Socket Assembly	3/4 in drive	Turning injection pump camshaft when setting lifters on D379, D398 and D399 Engines

<sup>1</sup> Comes with insert for removing spark plugs

## Timing Pins

Model: 1100, 3100, 3406, 3408, 3412, 3306, 3304 D.I.

Warranty: Six Months

Item	Part Number	Description	Model
1	6V-2112	Pin	1100 and 3100 Series and 3406 Engines
2	6V-6019	Pin	3408 and 3412 Engines
3	6V-4186	Pin - Fuel Pump Timing	3306 and 3304 D.I. Engines
<b>Not Shown</b>			
--	3P-1544	Pin	328 SMFS
--	4C-9581	Pin	3408/12 PEEC



## Timing Pins

Model: 3054 and 3056 Engines

Warranty: Six Months

- Used to install injection pumps on 3000 Series engines

Part Number	Description	Use
150-3992	Timing Pin	Required to install Bosch injection pumps
150-3993	Timing Pin	Required to install Lucas and Stanadyne injection pumps

## Decal for 1P-7410 Degree Wheel

Model: 3406B

Warranty: Six Months



- Used to time 3406 Direct Injection Truck Engines (1978 Truck Model Year) with static fuel injection timing
- Decal, SEHS7306, must be applied to early 1P-7410 Degree Wheels for accurate timing
- Decal provides timing marks in increments less than one degree

Part Number	Description
1P-7410	Degree Wheel

## 9U-5692 Spring Compressor

Model: 3406, 3408 and 3412 Engines

Warranty: Six Months



- Works on all three engines — 3406, 3408 and 3412
- Used to compress heavier lifter springs in pump when fuel pump plunger and barrel assemblies are removed and installed
- Clamps on side of pump housing and eliminates need to attach to adjoining pump

Part Number	Description
9U-5692	Spring Compressor

### References

SENR5148, Service Manual

SENR4658, Service Manual

## 318-6237 Rethreading Die Essential Tool

Model: 613C II, DV-613C II Scraper

Warranty: Six Months

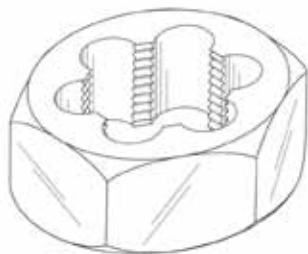

- Used to cut additional threads on 214-5491 Filler Neck
- Used with large wrench (dealer supplied)
- Additional threads allow gasket in fuel cap to seal against filler neck and prevent fuel/vapor leaks
- Current threads align die onto filler neck during use

Part Number	Description
318-6237	Rethreading Die

Thread size (inch)	4-12
Hex size	178 mm (7.0 in)
Material	steel

## 5P-6217 Fixture

### 5P-6218 Bearing Driver

Model: 3408, 3412

Warranty: Six Months

Part Number	Description
5P-6217	Fixture
5P-6218	Bearing Driver

- Used to install tapered fuel rack bearings on 3408 and 3412 Engines



## FT1251 Pump Housing Stand

Model: Cat® Engines

Warranty: None

- Fuel system components conveniently serviced on this stand
- Has rails that fit holding fixture from Fuel Injection Test Bench; by using appropriate FITB adapter plate and holding fixture, injection pump housings can be mounted on stand for disassembly and assembly, then easily moved to Test Bench for final adjustment and testing



## FT0960 Adapter Assembly

Model: 4.75 inch Bore Engines

Warranty: None

- Used to hold fuel rack in centered position when installing fuel pumps on all 12.07 cm (4.75 in) bore engines with compact fuel systems except D334 and 1674 Engines
- Material: mild steel

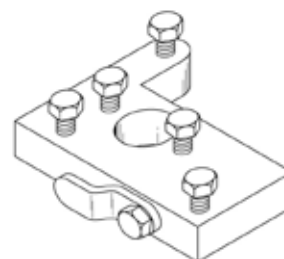

## 6V-4824 Driver

### 6V-4825 Plate

Model: 3406B

Warranty: Six Months



- Used to install D-shaped rack bearing in fuel injection pump housing on 3406B Engines
- 6V-4825 Plate, bolted to pump housing, pilots bearing as it is driven into position with 6V-4824 Driver
- Assure bearing installation to correct depth and angle

Part Number	Description
6V-4824	Driver
6V-4825	Plate

#### Reference

3406B Service Manual

## 7S-7113 Rack Setting Gauge

Model: D333, D330, D320, D311H

Warranty: Six Months



- Replaces 8M-0530 Gauge
- Measures rack travel in both fuel on and fuel off directions

Part Number	Description
7S-7113	Rack Setting Gauge

## 6V-7941 Overfueling Spring Compressor

Model: Cat® Engines

Warranty: Six Months



- Used to make fuel rack and fuel ratio control settings on engines with New Scroll Fuel Systems
- Replaces discontinued 6V-2128 Overfueling Spring Compressor
- Plunger travel in former 6V-2128 Compressor was limited by mechanical stops and would not permit checking full range of rack settings on above engines; 6V-7941 Compressor does not have internal stops, and thus will accommodate full range of rack settings

Part Number	Description
6V-7941	Compressor Assembly



## 6V-7942 Hook

Model: Cat® Engines  
Warranty: Six Months

Part Number	Description
6V-7942	Hook

- Used to pull rack against rack centering pin on engines with negative rack settings
- Necessary because on some of these engines, overfueling spring may not move rack against centering pin



## 158-8665 Rack Set Tool

### Essential Tool

Model: 3034 Engines  
Warranty: Six Months

Part Number	Description
158-8665	Rack Set Tool

- Used to adjust maximum fuel setting if timing case or fuel pump linkage are removed or repaired

### Reference

SENR5013, Disassembly and Assembly of 3034 Engine

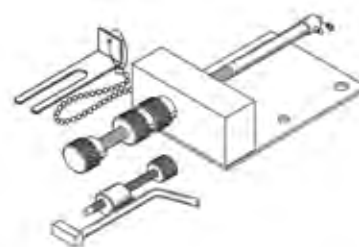

## 9U-5296 Rack Positioning Assembly

Model: 3204, 3300, and 3406 Series NSFS (Non-PEEC) Engines  
Warranty: Six Months

- Used to set injection pump rack while pump is being tested on test bench
- Used with FITB, FIETS, and AVM test benches

### Reference

NEHS0639, Tool Operating Manual

Overall length	171.4 mm (6.75 in)
Thread size	1/4 - 28
Bolt hole diameter	7.5 mm (0.30 in)
Distance between holes	63.6 mm (2.50 in)
Service part	6V-8187 Nut

Part Number	Description
9U-5296	Rack Positioning Assembly <sup>1</sup>

<sup>1</sup> Non-PEEC, 3406B and 3406C Rack Adjustment

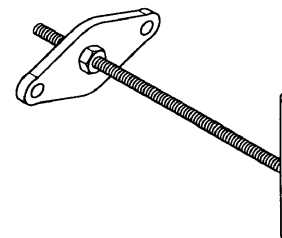

## 6V-9128 Rack Position Tool Group

Model: Cat® Engines

Warranty: Six Months

Engine Tools

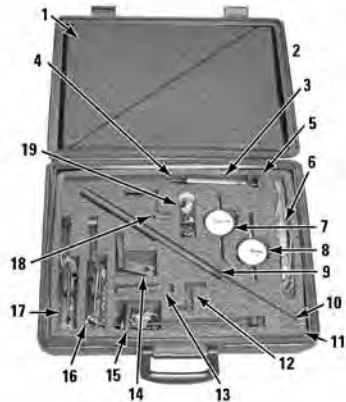

- Provides convenient and accurate way to set or check rack position on Cat® Engines
- Used to measure fuel rack position during normal operation of engine, or measure fuel rack position and make any necessary adjustments while engine is shut down
- Rack setting can be made or checked without removing injection pump
- Replaces discontinued 9S-0240 Rack Position Tool Group; both groups are identical, except new group contains metric dial indicators and low cost plastic case

### Reference

SEHS8436, Special Instruction

Item	Description
12	Spring

Item	Part Number	Description	Size
1	6V-9127	Liner	--
2	6V-7145	Case	--
3	9S-0239	Adapter Assembly	--
3 <sup>1</sup>	0S-1616	Bolt	25.4 mm (1/4 in - 20 x 1.00 in)
4 <sup>2</sup>	5S-8086	Contact Point	6.35 mm OD (0.25 in OD)
4	5S-8090	Rod Assembly	--
5	9S-8521	Rod	--
6	8T-0500	Light - Continuity Testing	--
7	6V-3075	Indicator - Dial	--
8	6V-6106	Dial Indicator	--
9	5S-8157	Extension	--
10	5S-8088	Rod Assembly	--
11	177-9037	Block	--
13	9S-7344	Clamp Assembly	--
14	9S-7343	Bracket Assembly	--
14	2A-0762	Bolt	16.0 mm (1/4in - 20 x 7/8 in)
15	9S-0227	Bracket Group	--
16	9S-0238	Bracket Group (not serviced)	--
17	9S-7350	Bracket Group (not serviced)	--
18	2H-0191	Bolt	16.0 mm (10 - 24 x 0.625 in)
18	9S-0225	Bracket Assembly	--
19	9S-8903	Point	9.50 mm (0.4 in)
19	8S-3675	Point - Indicator	3 mm (0.12 in)
19	3P-1565	Collet Clamp	--
19	5P-4814	Collet As - Clamp	--
19	9S-8518	Plug	--
19	3S-3268	Point - Indicator Contact	6.35 mm (0.25 in)
19	9S-0229	Contact Point	9.5 mm (0.4 in)
19	9S-8883	Contact Point	12.7 mm (0.5 in)
19	3S-3269	Contact Point	25.4 mm (1.0 in)
19	5P-7276	Container	--
19	9S-8519	Plug	--

(Continued)

## 6V-9128 Rack Position Tool Group (Continued)

Model: Cat® Engines  
Warranty: Six Months

Item	Part Number	Description	Size
--	6V-9128	Rack Position Tool Group	--
<b>Not Shown</b>			
--	4C-3474	Cap	--

<sup>1</sup>Also Item 13

<sup>2</sup>Also Item 10 and 19

## 9S-0227 Bracket Group

Item	Part No.	Description
--	9S-0227	Bracket Group
<b>Service/Repair Parts</b>		
2	8S-9456	Rod Assembly
5	9S-0234	Spacer
6	2A-0762	Bolt
7	5S-7348	Screw

Item	Description
1	Bracket Assembly
3	Plug
4	Rod

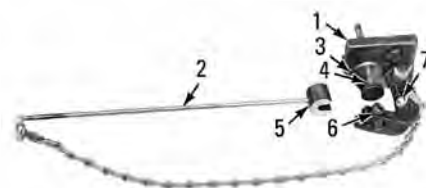

## Service / Repair Parts for Rack Position Tool Group

Item	Part No.	Description
<b>Service/Repair Parts</b>		
3	9S-0234	Spacer
4	8S-9456	Rod Assembly
5	2A-0762	Bolt
6	5S-7348	Screw
7	3F-9190	Dowel
9	9S-0231	Ring
9	9S-0213	Rod

Item	Description
1	Bracket Assembly
2	Plug
8	Hole Attachment

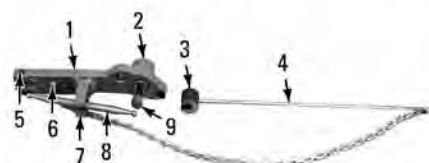

## 9S-0228 Rack Position Tool Group

### Discontinued — Service Parts Available

All part numbers in the table: Six Month Warranty

#### Reference

SEHS6995, rack setting procedure

Item	Part Number	Description
1	9S-0225	Bracket Assembly
1	2H-0191	Bolt
2	9S-8883	Contact Point
3	8S-2283	Indicator
--	9S-0228	Rack Position Tool Group



## 6V-6070 Tool Group

Model: Cat® Engines

Warranty: Six Months



- Used to check and adjust rack and fuel ratio control linkage on all engines with New Scroll Fuel Systems (NSFS) — new procedure now used to check and adjust rack on these engines
- Replaces discontinued 6V-4095 Group and discontinued 6V-4096 Group; all tools in discontinued groups, except 6V-2128 Compressor (which was discontinued), are still available for parts service

### Reference

SEHS8024, Special Instruction

Included in Group
Arm
Arm (Part of 6V-2014) (2)
Form SEHS8024
Form NEEG2119 (Label)
Form SEES5641 (Layout Chart)

Part Number	Description	Qty.
6V-6070	Tool Group	--
<b>6V-6070 Tool Group Contains</b>		
021-7956	Bolt	--
0S-1614	Bolt	2
0S-1615	Bolt <sup>1</sup>	2
2A-0762	Bolt	--
2P-8264	Socket	--
2P-8265	Socket	--
5B-5689	Gasket	--
5P-4814	Collet As - Clamp	2
6V-2014	Bracket Assembly <sup>2</sup>	--
6V-2017	Tool	--
6V-2030	Extension <sup>3,4</sup>	--
6V-2105	Tool As. - Rack ADJ	--

Part Number	Description	Qty.
<b>6V-6070 Tool Group Contains (Continued)</b>		
6V-3072	Case - Plastic, NEEG2574 Group Decal on lid (9U-7402 Group)	--
6V-3075	Indicator - Dial	--
6V-4186	Pin - Fuel Pump Timing	--
6V-6104	Block	--
6V-6105	Block	--
6V-6106	Dial Indicator	--
6V-6151	Adapter (Overfueling Spring Compressor)	--
6V-7941	Compressor Assembly	--
6V-7942	Hook	--
8H-3128	Bolt - Hex Socket Head	3
8H-9178	Bolt	2
8T-9198	Rack Indicator Bracket Assembly	--
9S-0229	Contact Point	--
9S-8903	Point	--

<sup>1</sup> Parts serviced separately.

<sup>2</sup> NOTE for 6V-2014, Bracket Assembly: An FT2532 Shield is available for the 6V-2014 Bracket Assembly. Refer to the separate article for specifications to make the oil shield.

<sup>3</sup> Used for FIETS and AVM with heavy duty coupling

<sup>4</sup> Part of 6V-6042 Indicator Contact Point Group

## FT2532 Oil Shield

Model: 3304 and 3306 Engines equipped with New Scroll Fuel Systems

Warranty: None

- Used to create a shield to prevent oil leaking from indicator bracket when checking fuel-to-air ratio with engine running
- Used with 6V-2014 Bracket Assembly, which is part of 6V-6070 Tool Group
- Oil shield fits over lever shaft mounting ears of indicator bracket
- Can be easily made from aluminum or steel
- Attaches to indicator bracket with 3S-6252 RTV Adhesive/Sealant
- After oil shield is installed, check for free movement of indicator lever



## 6V-4069 Body Group

Model: 3208

Warranty: Six Months

Item	Part Number	Description
--	6V-4069	Body Group
1	5L-4041	Bolt (2)
2	2H-0191	Bolt
3	6V-4088	Washer

- Used to remove fuel pump drive gear from taper on drive shaft before removing sleeve metering fuel system on 3208 Engines
- Replaces 5P-2371 Puller Plate (provides more pulling force than 5P-2371)
- Needed because of lack of space in vehicle



## 5P-4203 Sleeve Metering Field Service Tool Group

Model: Cat® Engines

Warranty: Six Months

- Used for disassembly, assembly, testing and adjusting Sleeve Metering Fuel System; used for fuel setting
- Metric tools; values for testing and adjusting given in metric pressures

As a result of changes and improvements in test and adjust procedures, the discontinued 3P-1550 Sleeve Metering Field Service Tool Group was converted to the 5P-4203 S.M.F.S. Tool Group. Dealers should check the list to determine what tools are required to convert their discontinued 3P-1550 Group to the 5P-4203 Group. Some parts of the discontinued 3P-1550 Group are no longer needed, but a number of items should be retained in case of the need for dynamic checking of sleeve shaft movement.

### Reference

SMHS7013, Special Instruction

Item	Description
9	FT1632 Bolt <sup>1</sup>
<sup>1</sup> FT1632 Bolt is made from 2H-3740 Bolt. Refer to following article.	

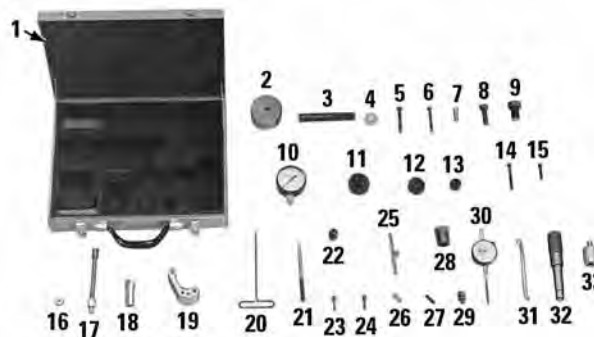

(Continued)

# Fuel System Repair and Adjust

## 5P-4203 Sleeve Metering Field Service Tool Group (Continued)

Model: Cat® Engines

Warranty: Six Months

Engine Tools

Item	Part Number	Description	Size	Qty.
1	3P-1549	Block	--	--
1	2P-8306	Box Assembly	--	--
2	5P-0301	Driver	--	--
3	1P-0529	Handle	--	--
4	4B-4280	Washer	--	2
5	1D-4538	Bolt	--	--
6	1D-4533	Bolt	--	--
7	3K-4910	Screw	--	--
8	0S-1603	Bolt	--	--
10	8B-8817	Plug (Not shown)	--	--
10	8T-0853	Gauge, 0 - 400 kPa(0 - 60 psi)	--	--
11	5P-0319	Driver	--	--
12	5P-0318	Driver	--	--
13	1P-0463	Plate	1.000 in Diameter	--
14	6L-5551	Bolt	2 1/4 in long	--
15	4L-7124	Bolt - Hex Socket Head <sup>1</sup>	1 1/4 in long	--
16	4B-4276	Flat Washer	--	4
17	6J-3958	Coupling	--	--
17	3B-7734	Adapter STR	76.2 long (1/8 in NPT x 3 in)	--
17	3J-7354	Seal - O-ring - STOR for 8C-3446 (not pictured)	--	2
17 <sup>2</sup>	5D-9231	Connector	--	2
18	3P-2210 <sup>3</sup>	Socket	--	--
19 <sup>45</sup>	5P-6602	Adapter	--	--
20 <sup>4</sup>	5P-4205	Wrench <sup>6</sup>	--	--

Item	Part Number	Description	Size	Qty.
21	3P-1544	Pin	--	--
22	4H-0553	Fitting	--	--
23	5P-0299	Pin	19.2831 mm (0.7592 in)	--
24	5P-0298	Pin	17.8587 mm (0.7028 in)	--
25 <sup>4</sup>	5P-4209	Gauge	--	--
26	3J-6956	Spring	--	--
27	8S-7271	Setscrew	--	--
28	8S-2243	Wrench	--	--
29	3P-1565	Collet Clamp	--	--
31	5P-0302	Bar (Injector Removal)	--	--
32	6V-0029	Roll Pin Depth Gauge Tool <sup>2</sup>	--	--
33 <sup>2</sup>	6V-3071	Seal Guide	--	--
--	5P-4203	Sleeve Metering Field Service Tool Group	--	--
<b>3P-1567 Indicator, Includes:</b>				
30	3P-1567	Indicator	--	--
30 <sup>4</sup>	5P-6531	Point	57.2 mm (2.25 in)	--
30 <sup>4</sup>	5P-4228	Spring	--	--
<b>The following parts which, were in the discontinued 3P-1550 Tool Group, should be retained in case of the possible need for dynamic checking of sleeve shaft movement<sup>7</sup></b>				
--	3K-6896	Gasket	--	--
--	0S-1616	Bolt	--	--
--	7B-2742	Bolt	--	--

<sup>1</sup> Part of 1P-0520 Driver Group

<sup>2</sup> Not included in early 5P-4203 Groups

<sup>3</sup> Special socket

<sup>4</sup> Tools which must be procured to convert the discontinued 3P-1550 Tool Group to the 5P-4203 Tool Group. The 3P-1567 Indicators from discontinued 3P-1550 Tool Groups must have the 5P-4228 Spring and 5P-6531 Contact Point installed. Some 3P-1567 Indicators had 5P-4809 Points, 50.8 (2.0 in) long.

<sup>5</sup> NOTE: The discontinued 5P-4226 Adapter was replaced by the 5P-6602 Adapter, which is required for 3208 Engines with EGR systems.

<sup>6</sup> Warranty: Six Months

<sup>7</sup> Also retain: Basket

## FT1632 Bolt

Model: D5B, D6D, D7G, 225B, 225B-3208, 3208, 518, 613C

Warranty: None

- Fabricated by modifying 2H-3740 Bolt in 5P-4203 Field Service Tool Group
- Used to remove 4N-2954 Sleeve modification prevents damage to threads

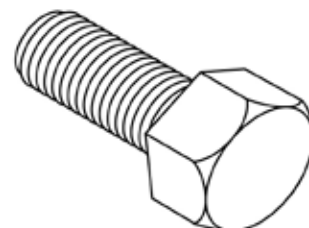

## 3P-2200 Sleeve Metering Calibration Tool Group

Model: Cat® Engines

Warranty: Six Months

- Used for calibrating (similar to lifter setting) sleeve metering fuel pumps in shop
- Several tools from 5P-4203 Tool Group also needed for this operation
- Metric tools; values for testing and adjusting are given in metric terms, with exception of torque values and pressures

### Reference

SMHS6988, Special Instruction



Item	Part Number	Description	Size
1	7W-8120	Bushing	--
10 <sup>1</sup>	5P-6557	Spring	--
2	1P-7379	Microgauge	--
3	3P-1568	Indicator	--
4	6V-3186	Collet	--
4	6V-3185	Base	--
5	5P-6510	Box Assembly	--

Item	Part Number	Description	Size
6	1S-9836	Wrench	--
7	3P-1546	Pin	15.9410 mm (0.62 in)
8	3P-1545	Pin	17.3734 mm (0.68 in)
9	3P-1540	Pump Assembly	--
--	3P-2200	Sleeve Metering Calibration Tool Group	--

<sup>1</sup> Part of pump assembly

## Additional Calibration Tools

Engine Tools



Item	Part Number	Description
<b>Additional Tools from 5P-4203 Tool Group Required for Pump Calibration</b>		
1	8S-2243	Wrench
2	5P-6602	Adapter
3	5P-4205	Wrench <sup>1</sup>
4	5P-4206	Wrench
5	1D-4533	Bolt
6	1D-4538	Bolt
7	5P-4209	Gauge
8	8S-7271	Setscrew
9	2P-8264	Socket
10	6V-0190	Clamp (2)

<sup>1</sup>Warranty: Six Months

## 5P-3516 Reaming Tool Group

Model: 225B, 225B-3208, 3208, 613C

Warranty: Six Months

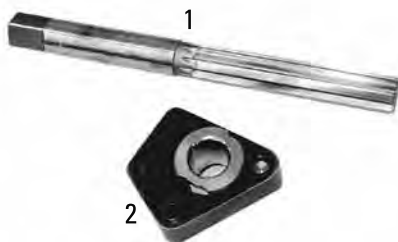

- Used to ream 5P-4810 Camshaft Bearing when front bearing requires replacement in sleeve metering fuel system pump housings

Item	Part Number	Description
--	5P-3516	Reaming Tool Group
1	5P-3515	Reamer
2	5P-3057	Fixture Assembly

## 6V-4164 Driver

### 6V-4163 Bit

Model: Cat® Engines

Warranty: Six Months



- Capable of applying torque required to remove and install mounting bolts for later 8N-2663 Flyweight Carrier in sleeve metering fuel systems

Item	Part Number	Description	Size
1	6V-4164	Driver	1/4 in Hex, 3/8 in Square Drive
2	6V-4163	Bit	1/4 in and 1/8 in Hex



**5P-6577 Fuel Setting Tool Group**

Model: Cat® Engines  
 Warranty: Six Months

- Contains only those tools needed for checking and adjusting fuel setting on engines with Sleeve Metering Fuel Systems
- All tools in this group also contained in 5P-4203 Field Service Tool Group

Item	Part Number	Description
1	1D-4533	Bolt
2	1D-4538	Bolt
3	5P-4205	Wrench <sup>1</sup>
4	3P-1544	Pin
5	3J-6956	Spring
6	5P-0299	Pin
7	5P-0298	Pin
8	5P-6602	Adapter
8	3P-1565	Collet Clamp
8	3P-1567	Indicator
8	8S-7271	Setscrew
8 <sup>2</sup>	5P-6531	Point
9	5P-7319	Box
--	5P-6577	Fuel Setting Tool Group

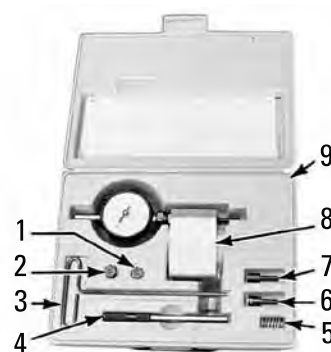

<sup>1</sup>Warranty: Six Months

<sup>2</sup>Part of 3P-1567

**Calibration Tools**

Model: 3208 Engines with Heavy Sleeve Metering Fuel System  
 Warranty: Six Months

- Used to set, test, and adjust heavy sleeve metering fuel pumps — these tools are not available as a group and should be ordered to supplement existing tool groups
- Used with 3P-2200 Sleeve Metering Calibration Tool Group, 5P-4203 Sleeve Metering Field Service Tool Group, and 5P-6577 Fuel Setting Tool Group
- The 3P-1565 Collet, 8S-7271 Setscrew, and 3J-6956 Spring are required for this operation and are part of 5P-4203 Sleeve Metering Field Service Tool Group or 5P-6577 Fuel Setting Tool Group
- A 6V-6082 Bit, 5/64 Hex, part of 6V-4980 Torque Screwdriver Tool Group, is required for 8S-7271 Setscrew to adjust the injection pumps
- 146-5068 Hex Key required for on engine adjustment for aftercooled engines
- All tools can be stored in a 6V-3073 Case; 6V-4094 foam (convoluted) is used in the lid; two foam blocks are required in the case bottom, 6V-4873 topped with 2P-8289 (convoluted); all foam is cut to fit the case

**References**

REHS0063, Special Instructions, Sleeve Setting  
 SENR3688, Service Manual

Item	Description
5	Original Load Stop Cover Bolts

(Continued)

## Calibration Tools (Continued)

Model: 3208 Engines with Heavy Sleeve Metering Fuel System  
 Warranty: Six Months

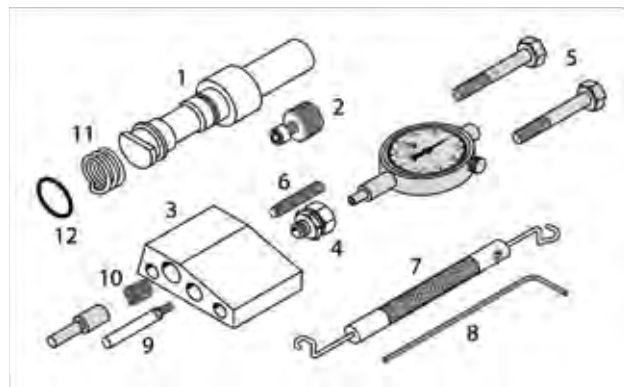

Item	Part Number	Description	Used with	Used to
1	141-6727	Calibration Pump Assembly, 3208 HSMFS	3P-2200 Calibration Tool Group for sleeve lever setting	Set sleeve lever position on control shaft during injection pump assembly
2	141-6737	Adjustable Micro-Gauge	3P-2200 Calibration Tool Group for sleeve lever setting	Preset sleeve lever position before final calibration (use a wicking sealant to lock screw in place the first time this gauge is used)
3	145-1853	Calibration Fixture	3P-2200 Calibration Tool Group for sleeve lever setting 5P-4203 or 5P-6577 for fuel setting adjustments	Hold calibrating and zero pins for rack setting and positioning control shafts for sleeve setting (required for all 3208 HSMFS and 3208 SMFS injection pumps)
4	3P-1565	Collet Clamp	--	--
6	8S-7271	Setscrew	--	--
7	131-3459	Sleeve Holder	--	Position sleeve during pump disassembly and assembly - simplifies assembly and protects sleeve from damage
8	146-5068	Hex Key-Ball End	--	--
9	5P-4809	Point Indicator	--	--
10	3J-6956	Spring	--	--
<b>Service parts for 141-6727 Calibration Pump Assembly</b>				
11	5P-6557	Spring	--	--
12	8T-0116	O-ring	--	--
<b>Recommended but not shown</b>				
--	6V-3073	Case - Plastic	--	--
--	2P-8289	Holder Block	--	--
--	6V-4873	Foam - Block	--	--
--	6V-4094	Foam - Convoluted	--	--

## FT1525 Alignment Pin, FT1526 Fixture

### FT1698 Driver

Model: 3208

Warranty: None

- Used to salvage governor housings on 3208 Engines with Sleeve Metering Fuel Systems
- Provide accurate method for maintaining proper location when reworking throttle shaft bushing bores; FT1525 Pin and FT1526 Fixture formerly used to rework only outer bore; with addition of FT1698 Driver and a longer drill and reamer, both bores can be reworked

#### Reference

SMHS7760-01, Special Instruction



## 6V-4141 Sleeve Metering Calibration Tool Group

Model: 3208

Warranty: Six Months

- Makes adjustment of sleeve levers easier on Sleeve Metering Fuel Systems
- When used with 6V-4980 Torque Screwdriver Tool Group, adjustment to sleeve levers on 3208 Engine takes about 5 minutes instead of 15 to 30 minutes
- Formerly, tolerances on sleeve lever had to be exact to 0.002 mm (0.00008 in); it was necessary to use 3P-2220 Calibration Tool Group to make an adjustment this exact; tolerances were changed to 0.05 mm (0.002 in) with a maximum of 0.05 mm (0.002 in) between each lever, and 6V-4141 Tool Group can make this adjustment accurately and faster

#### Reference

SMHS7835, Special Instructions



Item	Part Number	Description	Size
1	6V-4137	Fixture Group	--
2	3P-1545	Pin	17.3734 mm (0.68 in)
3	8T-0888	Washer	--
4	3P-1546	Pin	15.9410 mm (0.62 in)
--	6V-4141	Sleeve Metering Calibration Tool Group	--

## Fabricated Tools for Reconditioning 3208 Engine Fuel Systems

Model: 3208

Warranty: None



- Used to recondition 3208 Engine fuel systems

Item	Part Number	Description
1	FT1693	Holding Fixture
2	FT1690	Holding Fixture
3	FT1691	Parts Basket
4	FT1692	Parts Basket
5	FT1709	Holding Fixture
6	FT1730	Gauge (Weight)
7	FT1689	Holding Fixture
8	FT1776	Holding Fixture
9	FT1686	Remover Installer
10	FT1687	Socket
11	FT1777	Holding Fixture

## 6V-4830 Fixture Group

Model: Cat® Engines

Warranty: Six Months

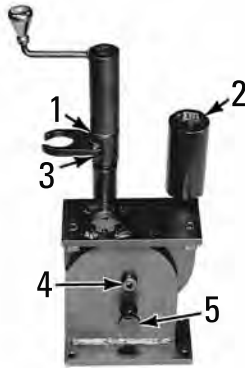

- Used for disassembly and assembly of unit injectors, and to check assembled injectors for free rack movement

Item	Description
4	Screw

Item	Part Number	Description
1	5L-1100	Bearing
2	6V-4092	Socket
3	2N-7229	Spring
5	6V-4875	Stop
--	6V-4830	Fixture Group

## 6V-6188 Cleaning Tray

Model: Cat® Engines

Warranty: Six Months



- Holds specific parts of unit injectors in groups while they are cleaned in ultrasonic cleaner tank
- Plungers, bushings, tips and needles arranged in sequence so that parts which fit together and must be kept together can be cleaned but not mixed
- Tray fits in tank of either ultrasonic cleaner group

Part Number	Description
6V-6188	Cleaning Tray

## 6V-4822 Tip Driver

Model: Cat® Engines  
Warranty: Six Months

Part Number	Description
6V-4822	Tip Driver

- Used to separate tip assembly from nut during disassembly of injector
- Can be used as alignment tool during assembly



## 149-2955 Seal Protector

## 149-2956 Backup Ring Installer

Model: 3126B Engines  
Warranty: Six Months

- Used to quickly install stiff O-ring and both backup rings in top groove of HI300 injector
- Prevents steel backup ring from deforming or damaging injector case during ring installation

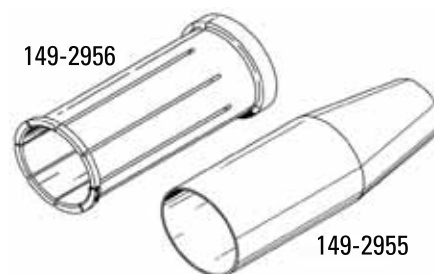

Part Number	Description	Overall Length	Outside Diameter (large end)	Inside Diameter (of large end)	Inside Diameter of taper	Inside Diameter
149-2955	Seal Protector	121 mm (4.76 in)	40 mm (1.57 in)	37.6 mm (1.48 in)	25.2 mm (0.99 in)	--
149-2956	Backup Ring Installer	105 mm (4.13 in)	--	--	--	40.75 mm (1.60 in)
<b>Service Part</b>						
5F-9657	O-ring seal	--	--	--	--	--

## 192-5092 Removal Tool

Model: 3126B Engines  
Warranty: Six Months

Part Number	Description
192-5092	Removal Tool

- Used to easily separate hose from fitting
- Used on #10 fitting on 192-2963 Oil Supply Hose on HEUI high-pressure pump
- Separates fitting from hose collar (insert beveled edge between hose collar and fitting)
- For #6 fitting use 180-0186 Hose Tool

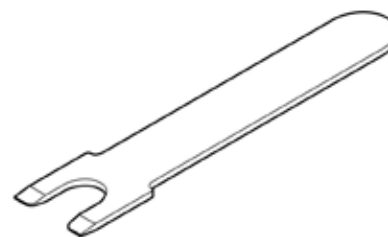

## 180-0186 Removal Tool

Model: 3126B HEUI Engine

Warranty: Six Months

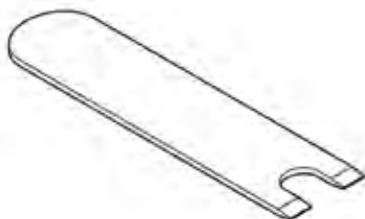

- Used to quickly and easily separate 175-3236 High-Pressure Hose from fitting
- Insert beveled edge between fitting collar and hose collar; hose should release from fitting

Part Number	Description
180-0186	Removal Tool

## 250-6092 Removal Tool

### Essential Tool

Model: C15 and 3456 Engines

Warranty: Six Months

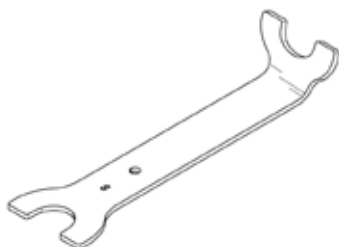

- Used to quickly and easily separate a hose from a #8 fitting
- Used on C15 Engine turbocharger supply line and 3456 Engine crank-gear
- Insert edge of tool between fitting and hose collar to release hose from fitting
- Helps prevent hose damage — angled end of tool allows hose to be pushed off of fitting
- Other hose release tools also available: #6 180-0186 and #10 192-5092

Part Number	Description
250-6092	Removal Tool

## Injector Installation and Removal Tooling

### Essential Tool

Model: 3126B, C7, C9 Engines

Warranty: Six Months

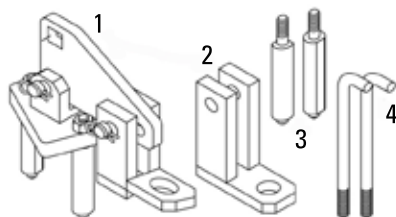

- Used to push injector into bore (attaches to rocker shaft bolt)
- Used with 1/2 inch drive ratchet to apply force to raise or lower injector
- Lever action provides fast and easy installation
- Eliminates injector damage which can occur when using other installation methods
- Order parts separately

#### References

SENR9664, C9 Marine Engine

REN9218, C7 Engine for Cat Built Machines

REN9579, C9 Engine For Cat Built Machines

REN7458, C7 On Highway Engine

(Continued)

## Injector Installation and Removal Tooling (Continued)

### Essential Tool

Model: 3126B, C7, C9 Engines

Warranty: Six Months

Item	Part Number	Description	Used with	Used To	Used On
<b>Injector Installation and Removal Tooling</b>					
1	152-1057	Injector Installation Tool	--	Install injectors	3126B
2	191-6077	Bracket	152-1057 Injector Installation Tool (replaces standard bracket assembly)	Install injectors	C9
3	272-1149	Leg (2 pieces)	152-1057 Injector Installation Tool (replaces standard legs)	Install injectors	C7, C9 (after 06/2004)
4	274-9198	Rod (2 required)	152-1057 Injector Installation Tool	Remove injectors	C7, C9 (after 06/2004)

### 367-3070 Injector Installation and Removal Tooling

Model Usage: C7, C9 Engines

Warranty: Six Months

- Used to safely remove and install injector
- Threaded tabs captured between injector clamp and head, allowing threaded rod to be turned with 4 mm hex wrench to jack out injector clamp
- Threaded rods can be installed into head thread end down and injectors can be pulled into head with M8 nuts
- M8 nuts supplied
- Lubricant suggested on threaded rods to reduce friction

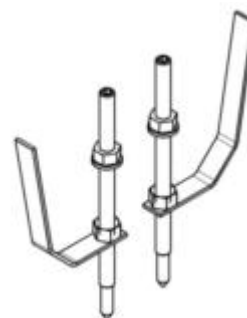

Specifications	
Part Name	Description
Threaded Rods	M8 x 1.25
Hex Wrench	4 mm

Part Number	Description
367-3070	Injector Installation and Removal Tooling

### 6V-4808 Tip Tester Adapter Group

Discontinued — Service Parts Available

Item	Part Number	Description
3	6V-1250	Seal
4	6F-0722	Seal
--	6V-4808	Tip Tester Adapter Group

Item	Description
1	Nut
2	Body



# Fuel System Repair and Adjust

## 9U-5132 Timing Tool Group

Model: 3500 EUI and MUI Engines

Warranty: Six Months

- Replaces discontinued 6V-7880 Tool Group (to upgrade 6V-7880 to 9U-5132, order 6V-3072 Plastic Case, 9U-5138 Set Gauge, 9U-5233 Timing Fixture, 9U-5136 Foam Insert, 129-8602 Solenoid Nut Driver, and Decal NEEG2515)
- Used to test and adjust fuel systems, including fuel timing, rack synchronization, and fuel setting
- Tool group can be used for both MUI (Mechanical Unit Injector) and EUI (Electronic Unit Injector) engines
- 136-4587 Collet Extension and 136-4588 Collet Extension can also be used with this tool group (use 136-4587 for 9U-6273 and 136-4588 for 122-0449)

### Reference

NEHS0666, Tool Operating Manual

	Set Gauge Step	Rod Sleeve Extension	Extension Rod Assembly
For EUI engines use	64.34 mm (2.533 in)	122-0449	122-0451 [124.0 mm (4.78 in) long]
For MUI engines use	87.00 mm (3.425 in)	9U-6273	9U-5220 [181.0 mm (7.12 in) long]

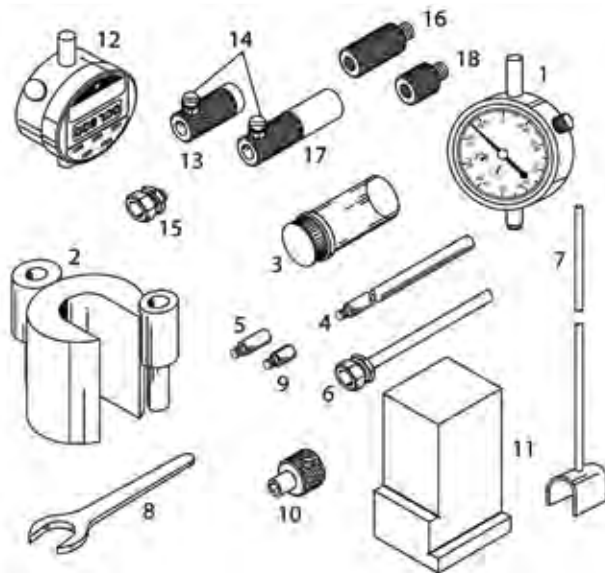

Item	Part Number	Description	Size
1	6V-3075	Indicator - Dial	--
2 <sup>1</sup>	9U-5137	Timing Fixture	--
3	5P-7276	Container	--
4	5P-7263	Indicator Contact Point	76.2 mm (3.0 in)
5	9S-8883	Contact Point	12.7 mm (0.5 in)
6	4C-8753	Extended Collet	--
7	8T-2684	Rack Synchronization Gauge	12.7 mm (0.5 in)
8	6V-7918	Wrench	5/8 in
9	8S-3675	Point - Indicator	3 mm (0.12 in)
10	129-8602	Solenoid Nut Driver	--
11	9U-5138	Set Gauge	--
13 <sup>2</sup>	9U-6273	Rod Sleeve Extension	--
14 <sup>2</sup>	9U-6272	Nylon Screw	--
17 <sup>2</sup>	122-0449	Rod Sleeve Extension	--
--	9U-5132	Timing Tool Group	--

(Continued)



## 9U-5132 Timing Tool Group (Continued)

Model: 3500 EUI and MUI Engines

Warranty: Six Months

Item	Part Number	Description	Size
<b>Optional Tooling</b>			
12	369-2607	Digital Indicator	--
15	5P-4814	Collet As - Clamp	--
16	136-4588	Collet Extension	--
18	136-4587	Collet Extension	--
<b>Not shown</b>			
--	5P-4160	Point - Indicator Contact, 19.05 mm (0.75 in) long	19.0 mm (0.75 in) (for digital indicator)
--	9S-9082	Turning Tool, 1/2 in drive	1/2 in drive
--	6V-3072	Case - Plastic, NEEG2574 Group Decal on lid (9U-7402 Group)	--
--	9U-5220	Extension Rod Assembly	--
--	9U-5136	Foam Insert	--
--	122-0451	Extension Rod Assembly	--

<sup>1</sup>Part of 9U -5233 Magnetic Fixture Group

<sup>2</sup>Additional tooling required, but not part of 9U-5132

## Collet Extensions

Model: 3500 and 3500B Engines

Warranty: Six Months

- Used to hold a dial indicator in 9U-5233 Fixture Group with 5P-4814 Collet Clamp and two (2) 6V-7918 Collet Wrenches
- Released to provide an alternative to the nylon screw-type indicator mount
- Use 136-4587 Extension-Collet with 5P-4814 Collet-Clamp, instead of 9U-6273 Rod Sleeve Extension, to check and adjust fuel timing on 3500 MUI Engines
- Use 136-4588 Extension-Collet with 5P-4814 Collet-Clamp, instead of 122-0449 Rod Sleeve Extension, to check and adjust fuel timing on 3500B EUI Engines

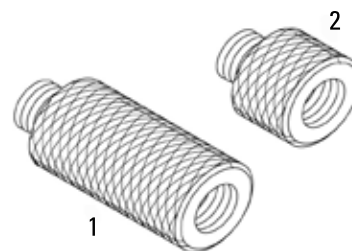

Part Number	Overall Length	Diameter	Extension Length	External Thread	Internal Thread
136-4587	56.5 mm (2.2 in)	19 mm (0.7 in)	47 mm (1.85 in)	7/16 - 20	3/8 - 16
136-4588	23 mm (0.9 in)	19 mm (0.7 in)	13.5 mm (0.53 in)	7/16 - 20	3/8 - 16

## 6V-6999 Lapping Plates

Model: Cat® Engines

Warranty: Six Months

- 3 lapping plates assembled in discontinued 6V-7011 Lapping Plate Case make a complete lapping set
- Lapping set permits distribution of lapping work between the 3 plates
- Makes it possible to lap plates against each other to make them flat after a period of use
- All parts need to be ordered separately

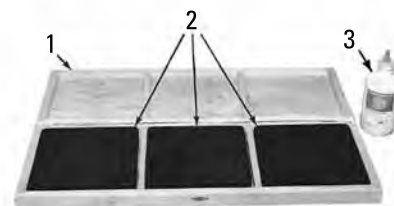

(Continued)

## 6V-6999 Lapping Plates (Continued)

Model: Cat® Engines

Warranty: Six Months

Item	Part Number	Description
1	6V-7011	Lapping Plate Case
2	6V-6999	Lapping Plate
3	6V-7151	Lapping Compound

## 6V-7151 Lapping Compound

Model: Cat® Engines

Warranty: Six Months

- Recommended to lap flat surfaces of parts used inside unit injectors
- Soluble (can be mixed with) in either solvent or water, and can be washed off with water
- Easier to use and to remove than 8S-2259 Compound, part of 8S-2245 Tool Group for pencil-type fuel nozzles, which will give an acceptable surface finish and can be used if desired
- In dispenser-type container (squeeze bottle)
- Contents: 0.454 kg (16.0 oz)

Part Number	Description
6V-7151	Lapping Compound

## 1U-9395 Plate

### 1U-8701 Socket

Model: Cat® Engines

Warranty: Six Months



1U-9395



1U-8701

- Used with 6V-4830 Fixture Group and 6V-4822 Tip Driver to remove and install nozzle on type 2 3500 Engine unit injector (type 2 unit injectors are described in January 1987 Engine News as those with two-piece follower)
- Make it possible to replace nozzle assemblies that plug or fail; with 1U-9395 Plate installed on 6V-4830 Fixture Group, injector can be held properly to remove and install nozzle assembly
- Early nose cones on type 2 injectors have serrations on cone that are damaged during removal; 7C-9795 Replacement Cone available with a hex to tighten it; 1U-8701 Socket required to tighten cone when replacing nozzle

#### Reference

SEHS8993, Special Instruction

Part Number	Description
1U-9395	Plate
1U-8701	Socket

## 223-2454 Fuel System and Governor Tool Group, 3114-3116

Model: 3114, 3116, and 3126 Engines

Warranty: One Year

- Replaces discontinued 1U-6680 Tool Group
- Used to simplify the required testing and adjusting operations
- Allows more precise fuel system adjustments in significantly less time, at less cost, than using previous tooling
- Improvements to tool group are described below

#### References

NEHS0610, Tool Operating Manual

SEBR0551, Service Manual, 3116 Diesel Truck Engine

SENR3583, Service Manual, Systems Operation, Testing and Adjusting, Basic Engine Components — 3114 and 3116 Engines  
Timing

(Continued)

## 223-2454 Fuel System and Governor Tool Group, 3114-3116 (Continued)

Model: 3114, 3116, and 3126 Engines

Warranty: One Year

### 123-4940 Magnetic Base Indicator Group

- Attaches directly to tappet on top of each unit injector
- Saves time — moves from cylinder to cylinder quickly and easily
- Use with 9U-7274 Contact Point

### 369-2607 Digital Indicator

- Has a programmable preset feature
- Allows direct reading of published timing dimensions
- Used with the 9U-7269 Timing Gauge Block

Synchronization

### 9U-7270 Synchronization Gauge Block

- Used to set #1 injector to 3.5 mm (0.14 in) rack (gives more accurate and consistent results)
- Used on 127-8207 Injector

### 220-0123 Synchronization Gauge Block

- Used to set #1 injector to 3.0 mm (0.12 in) rack (gives more accurate and consistent results)
- Used on 127-8213 Injector

### 128-9640 Injector Synchronization Fixture Group

- Used to hold linkage in synchronizing position for all cylinders
- Allows both hands to be free when making adjustments
- Provides more consistent results by applying a constant spring load to the linkage

### 9U-7264 Linkage Lever

- Used to actuate linkage when zeroing rack position at each injector
- Includes 1U-6235 Knob

Fuel Setting

### 128-8827 Governor Pin Assembly

- Used to properly position injector control linkage relative to governor housing face when making static rack power setting
- Required for 1994 and later governors where calibration pin connection is not accessible from rear of governor (also works for earlier version governors)

### 136-4149 Governor Connection Sleeve Pliers

- Used to move linkage cover tube between governor and head to gain access to governor/rack linkage connection
- Pliers have more gripping force than former 6V-0006 Pliers (easier to move stubborn cover tubes)
- Pliers have self-locking feature of Vice-Grip type pliers
- Coated with vinyl material to prevent damage to sleeve (refer to Modifications section for reworking older pliers)

### NOTE:

The discontinued 1U-6681 Holding Tool (not included) is still needed for some model governors.

The following list of tools is broken down into essential tools, recommended tools and improved tools. Many tools used in the discontinued 1U-6680 Tool Group are used again in 223-2454 Tool Group. See footnotes for status of tool.

If desired, the discontinued 1U-6680 Tool Group can be updated to a 223-2454 Tool Group by ordering those items with footnotes 1 and 2. Unless otherwise specified, quantity required is one of each item.

Item	Description
NEEG2688 (not shown)	Decal

(Continued)

# Fuel System Repair and Adjust

## 223-2454 Fuel System and Governor Tool Group, 3114-3116 (Continued)

Model: 3114, 3116, and 3126 Engines

Warranty: One Year

Engine Tools

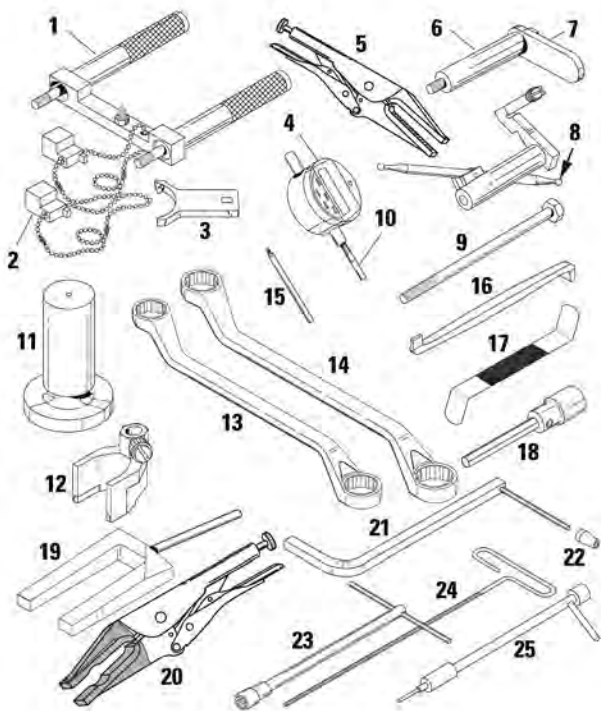

Item	Part Number	Description	Size
1 <sup>1</sup>	128-9640	Injector Synchronization Fixture Group	--
--	223-2454	Fuel System and Governor Tool Group, 3114-3116	--
<b>128-8706 Spring Plunger (serviceable part)</b>			
2	220-0123	Sync Gauge Block	3.0 mm (0.12 in)
2 <sup>1</sup>	9U-7270	Sync Gauge Block	3.5 mm (0.14 in)
3	9U-5120	Spanner Wrench	--
4 <sup>1</sup>	369-2607	Digital Indicator	--
5 <sup>1</sup>	128-8823	Locking Long Nose Pliers <sup>2</sup>	238 mm (9.375 in) long
6	1U-6675	Injector Spring Compressor	--
7	8T-4177	Bolt (spring compressor)	--
8	9U-7282	Indicator Fixture Group	--
<b>9U-6272 Nylon Screw (serviceable part)</b>			
9	8C-4984	Bolt, (indicator stand)	--
10 <sup>1</sup>	9U-7263	Contact Point	18.5 mm (0.73 in) long
<b>Fuel Timing Tooling</b>			
11 <sup>1</sup>	9U-7269	Timing Gauge Block	--
12 <sup>13</sup>	123-4940	Magnetic Base Group	--
13 <sup>1</sup>	128-8824	Deep Offset Wrench	(16 and 18 mm)
14 <sup>1</sup>	128-8825	Deep Offset Wrench (17 and 19 mm)	--
15	9U-7274	Contact Point	85 mm (3.35 in) long

(Continued)

## 223-2454 Fuel System and Governor Tool Group, 3114-3116 (Continued)

Model: 3114, 3116, and 3126 Engines

Warranty: One Year

Item	Part Number	Description	Size
<b>Miscellaneous Engine Tools</b>			
16 <sup>4</sup>	5P-0302	Bar (Injector Removal)	--
17 <sup>1,4</sup>	123-4941	Valve Setting Gauge	--
18 <sup>1,4</sup>	194-3542	Hex Socket Bit Driver	5 mm
<b>Fuel Setting Tooling</b>			
19	130-2711	Fuel Setting Holding Tool	--
20	136-4149	Governor Connection Pliers	--
21 <sup>1</sup>	128-8827	Fuel Setting Pin Assembly	--
22 <sup>1,4</sup>	1U-7523	Pilot - Pin Insertion	--
23 <sup>1</sup>	1U-7299	Adjustment (FRC) Wrench ("Type V" 1994 and later Trucks)	--
24 <sup>1</sup>	1U-7300	Wrench (3 mm Hex)	3 mm
25 <sup>5</sup>	1U-6673	Wrench - Fuel Ratio Control Adjusting and Synchronizing	--
<b>Not shown</b>			
1	6V-7145	Case	--
--	128-8828	Foam Insert Group	--

<sup>1</sup> Recommended or improved tools.

<sup>2</sup> Early 128-8823 were 150 mm (6.0 in)

<sup>3</sup> Some of the former 9U-7305 Groups used the new 123-4940 Magnetic Base; check your specific tool group.

<sup>4</sup> Refer to the appropriate engine Service Manual for additional information on use of these tools.

<sup>5</sup> 159-1783 Fuel Ratio Control Adjusting Wrench is 51 mm (2 in) shorter than 1U-6673. Required for 3116-3126 Engines in Challenger 35, 45 and 55.

### Modifications

#### 180-7956 Clamp Assembly Kit

Part Number	Description
180-7956	Clamp Assembly Kit

Installing 180-7956 Clamp Assembly Kit may interfere with 128-9640 Injector Synchronization Fixture Group during synchronization procedures. Modify the injector synchronization plate by machining an additional 6.5 mm (0.25 in) from plate (Refer to FT2727).

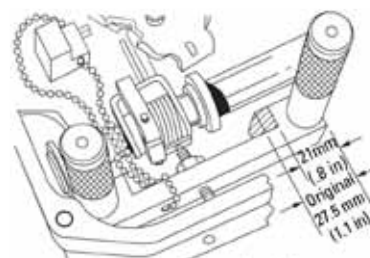

Remove shaded area, as shown

#### FT2727 Injector Synchronization Plate

Part Number	Description
FT2727	Injector Synchronization Plate

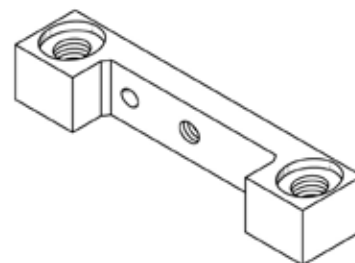

## 136-4149 Governor Connection Pliers

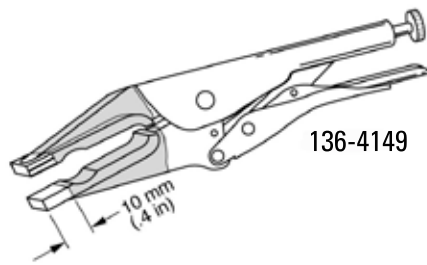

The 136-4149 Governor Connection Pliers can be used for inspection procedures as outlined in Special Instruction REHS0601, if modified. Remove 10 mm (0.4 in) of rubberized coating from tips of pliers to expose metal teeth. This modification will not affect the original function of pliers, and it will allow pliers to fit onto rivet head.

Part Number	Description
136-4149	Governor Connection Pliers

Engine Tools

## 1U-6680 Governor and Fuel Injection Adjusting Tool Group

### Discontinued — Service Parts Available

Warranty: All part numbers in the table have a Six Month warranty



Part Number	Description
1U-8702	Injector Timing Block
1U-6678	Fixture Group
8T-0267	Socket Head Bolt
4C-4716	Injector Timing Fixture
6V-6106	Dial Indicator
1U-8815	Point - Indicator Contact
3S-3268	Point - Indicator Contact
1U-6679	Indicator Group <sup>1</sup>
1U-9563	Offset Wrench
1U-8790	Nut Driver, 6 mm
6V-7918	Wrench
1U-7563	Hex Wrench, 4 mm
1U-7564	Hex Wrench, 5 mm
6V-0006	Electrical Connector Pliers

Part Number	Description
9U-5120	Spanner Wrench
1U-6675	Injector Spring Compressor
1U-6672	Rack Adjusting Wrench
1U-6673	Wrench - Fuel Ratio Control Adjusting and Synchronizing
1U-7523	Pilot - Pin Insertion
1U-7305	Insertion Tool
1U-6680	Governor and Fuel Injection Adjusting Tool Group
<b>Not shown</b>	
4C-5851	Foam Insert
5P-0302	Bar (Injector Removal)
5P-4814	Collet As - Clamp
6V-7145	Case

<sup>1</sup>Includes: 8T-7352 Bolt

## 1U-9563 Offset Wrench

Model: 3114, 3116

Warranty: Six Months

- Replaces discontinued 1U-8771 Offset Wrench
- Special wrench required for adjusting valve lash and injection timing on 3114 and 3116 Engine
- 4 necessary socket sizes — 16, 17, 18, and 19 mm
- Offset for clearing intake manifold

(Continued)

## 1U-9563 Offset Wrench (Continued)

Model: 3114, 3116

Warranty: Six Months

Part Number	Description
1U-9563	Offset Wrench

- Has all metric socket sizes required to adjust valve lash on any 1.1 liter engine; discontinued 1U-8771 Offset Wrench had 2 sizes, 17 mm and 19 mm; world standards for metric fasteners changed and affected 1.1 liter engine; for example, early engines have 17 mm and 19 mm locknuts; later engines have 16 mm and 18 mm locknuts; interim period of engines may have combination of sizes of locknuts; no special serial number break exists for different size locknuts

## 9U-5129 Seal Remover

Model: 3176

Warranty: Six Months

Part Number	Description
9U-5129	Seal Remover

- Used to remove copper combustion gas seal from unit injector tip on 3176 Engines
- Designed for quick removal without damaging injector; stretches copper seal so it can be removed by hand (pliers or chisels would likely damage injector)
- Has short chisel points that indent copper seal when tool is struck with small hammer; chisel points are shorter than seal thickness to prevent damage to injector

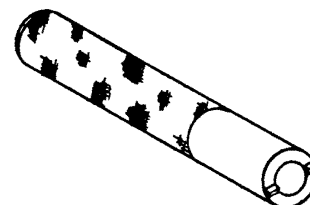

## 5P-2413 Air Regulator Assembly

Model: 16G

Warranty: Six Months

- Enables use of shop air pressure to activate air-fuel ratio controls for checking or setting fuel rack or rack limiter
- Applicable to both mechanical and hydraulically operated controls

### References

SMHS7083, Special Instruction

SEHS7465, Special Instruction

Item	Part Number	Description
1	3B-7262	Nipple
2	4H-0553	Fitting
--	5P-2413	Air Regulator Assembly



## 195-0761 Pressure/Vacuum Pump Group

Model: 3000 Series Engines With Stanadyne Fuel Injection Pumps

Warranty: Manufacturer's 5 year (see details)

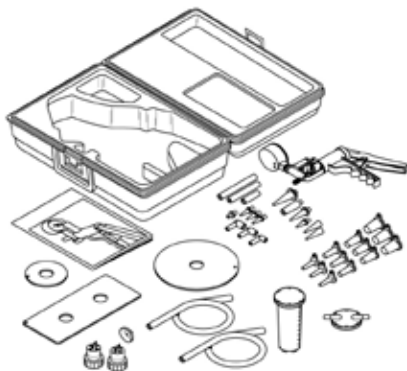

- Used to check and adjust aneroid capsule
- Includes other accessories for general diagnostic, testing, and adjusting procedures requiring vacuum or pressure
- Compound pressure gauge
- Hand-operated, no external power required
- Includes compact carrying case

### Warranty Information

The pump is warranted to be free of all defects in material and workmanship for FIVE FULL YEARS from the date of original purchase. This warranty does not apply to any defects caused by negligence of the user, use of the product in any manner other than in accordance with the instructions provided with the product, or damage caused by accidents. It also does not apply to gauges, which are warranted for a period of 90 days from date of purchase.

### Repair Information

Prism Enterprises, Inc.  
 6952 Fairgrounds Parkway  
 San Antonio, TX 78238  
 Phone: (800) MITYVAC (648-9822)  
 (210) 520-8051  
 Fax: (210) 520-8039  
 Web site: [www.mityvac.com](http://www.mityvac.com)

Maximum vacuum at sea level	-85 kPa (23 - 25 in Hg)
Single stroke volume	16.4 cu cm (1.0 cu in)
Maximum pressure unassisted	100 kPa (15 psi)
Maximum pressure assisted	175 kPa (25 psi)
Compound pressure gauge range	100 kPa (-30 mm Hg) - 200 kPa (30 psi)
Vacuum gauge accuracy -85 kPa (15 - 30 in Hg)	3% of full range

Part Number	Description
195-0761	Pressure/Vacuum Pump Group



## FT1906 Air Test Kit

Model: 16G

Warranty: None

- Used to check leakdown rate of fuel-air ratio controller with engine at low idle
- Used to read dynamic fuel-air ratio control setting
- Used to adjust fuel-air ratio control setting

### Reference

SENR5594, 3306B Engine

Item	Description
9	Air Pressure Bulb, BAUMA NOMETER No. 1890 or equivalent
14	Tubing, 1.2 mm (0.4 in) latex, 6.35 mm (0.25 in) inside diameter

Item	Part Number	Description
1	9S-8138	Gauge or 2.6 V-7775 Gauge
3	3B-6768	Adapter - STR (NPTF)
4	5P-4459	Elbow
5	5P-6011	Air Line
6	5P-4405	Connector
7	6N-3169	Hose Assembly (not serviced)
8	8L-6557	Adapter
10	5P-4476	Connector
11	6K-5741	Drain Cock
12	6V-6757	Elbow
13	7B-0192	Cross Fitting

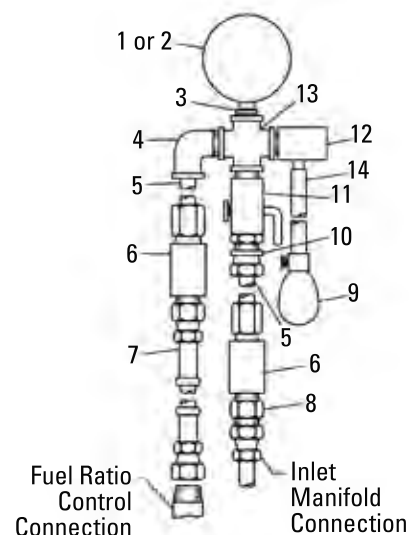

## 6V-9052 Piston Seal Guide

## 6V-9072 Piston Seal Guide

Model: D40D, D400D, 3406, 3406B

Warranty: Six Months

Part Number	Description
6V-9052	Piston Seal Guide
6V-9072	Piston Seal Guide

- Used to help install piston assembly in fuel ratio control body



## FT1820 Assembly Fixture

Model: Cat® Engines  
Warranty: None



FT1820 (Change No. 1)

- Redesigned (simplified) combination of former FT1820 (Change No. 0) and FT1821 Fixtures
- Inexpensive device used to hold fuel ratio controls; fuel ratio controls are awkward to hold during disassembly and assembly

## 159-0271 Solenoid Spanner Wrench

### Essential Tool

Model: 3208 Engine with Air/Fuel Ratio Control Override Solenoids  
Warranty: Six Months



- Used to install solenoid
- Used with 3/8 inch drive torque wrench
- For installation only — DO NOT USE TO REMOVE SOLENOID

Part Number	Description
159-0271	Solenoid Spanner Wrench

Square drive	3/8 in
Solenoid torque specification	20 ± 5 N·m (15 ± 4 ft-lb)
Torque wrench setting	16 ± 4 N·m (12 ± 3 ft-lb)

## FT1585 Plate

Model: 3300, 973, 973LGP  
Warranty: None

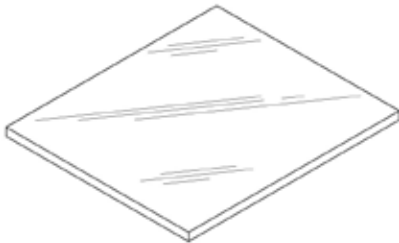

- Used for replacing worn governor spring guides in 8N-2500 Governor Housing on 3300 Direct Injection Engines with scroll fuel systems
- Used to control spring guide depth in governor housing; spring guide installed so its end is 1.40 ± 0.25 mm (0.055 ± 0.010 in) below surface of housing
- Material: 17-gauge mild steel

## 8T-3226 Ring Expander

Model: 3300, 3406

Warranty: Six Months

- Used for ring expanding and seal protection on all 3300 New Scroll Fuel Systems and on all 3406 New Scroll Fuel Systems
- Primary function: expander tool used with 6V-2163 Spring Compressor to install 7N-8821 Retaining Ring on weight carrier shaft; upon compression of spring assembly, 8T-3226 Ring Expander is inserted over end of weight carrier shaft; 7N-8821 Ring is then slid down over ring expander to its proper place on shaft
- Separate but important function: tool used to protect 4N-0820 Tachometer Drive Seal when assembling rear governor housing by placing ring expander over weight carrier shaft prior to assembling governor housing; rear governor housing that includes tachometer drive seal is then installed by placing it over ring expander; pre-assembled seal is protected from damage due to its position on housing; rounded top of ring expander guides seal into its proper position on carrier shaft

8T-3226 Ring Expander used as Seal Guide shown protecting seal



Part Number	Description
8T-3226	Ring Expander

## 8T-5223 Reamer

Model: 3406B

Warranty: Six Months

Part Number	Description
8T-5223	Reamer, Same as FT1949

- Used to bore 8N-9679 Governor Housing on 3406B Engine to install 8N-3945 Bushing and to salvage terminal shaft (throttle) bearing bores
- Released as supplement to existing FT drawing for dealers who do not have facilities to make FT tool

Part Number	Description
FT1951	Bushing-Drill (Part of FT1950)

## 8T-3222 Governor Adjusting Tool Group

Model: 3406B

Warranty: Six Months

Item	Part Number	Description
--	8T-3222	Governor Adjusting Tool Group
1	5P-4205	Wrench <sup>1</sup>

- Socket handle assembly along with the 5P-4205 Wrench used to adjust high idle on 3406B Engine while in the vehicle
- Remove high idle adjusting screw cover, install 8T-3222 Governor Adjusting Tool Group over locknut, loosen locknut, adjust high idle screw using 5P-4205 Wrench and retighten locknut; remove tool group and replace cover on governor



<sup>1</sup>Warranty: Six Months

## 4C-4354 Applicator

Model: 3114, 3116

Warranty: Six Months

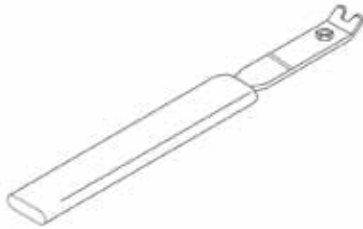

- Required to install Waldes Truarc ring (9X-2315 Retaining Ring, Series 5139-18) on servo on the 3114 and 3116 Governor
- Truarc ring requires a special applicator for installation; 4C-4354 Applicator grasps ring in a recess on underside of tool and holds it tightly under spring tension with an arm which extends over center section; tool angled so ring can be flattened to enter groove; when prongs have cleared shaft and ring is locked in groove, applicator can be withdrawn easily

Part Number	Description
4C-4354	Applicator

## FT1069 Driver

Model: 621

Warranty: None

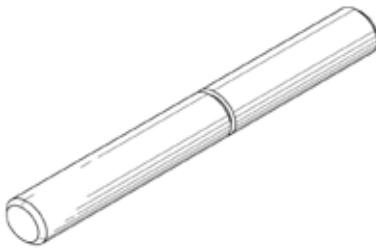

- Used to remove seal and cage assemblies from fuel transfer pump on 621 Engine

## Fuel Transfer Pump Assembly Tools

Model: 3406, 3408, 3412

Warranty: Six Months



- Used for assembly of fuel transfer pump on 3406, 3408 and 3412 Engines

Item	Part Number	Description
1	5P-2391	Seal Driver
2	5P-2392	Seal Driver

## 6V-6169 Check Valve Installer

Model: 3204, 3304B, 3306B, 3406B Series Engines with New Scroll Fuel Systems (NSFS)

Warranty: Six Months

Part Number	Description
6V-6169	Check Valve Installer

- Used to install check valves in fuel transfer pumps



## 1P-2385 Protractor Assembly

Model: D10, D6H, D7G, D8H, 224, 977L

Warranty: Six Months

Part Number	Description
1P-2385	Protractor Assembly

- Precision tool for measuring all governor linkage angles
- Used on any linkage assemblies that are adjusted by "angle" method

### Reference

SMHS7188, Special Instruction illustrates Woodward Governor linkages including correct linkage dimensions and angles



## 2P-8278 Fuel Flow Tube

Model: Cat® Engines

Warranty: One Year

Part Number	Description
2P-8278	Fuel Flow Tube

- Install this tube in engine fuel inlet line to determine amount of air entrained in fuel



# Fuel System Repair and Adjust

## 377-5782 High Pressure In-Line Flow Sight

Model Usage: C13, C15, 3204, 3300, 3406B, 3406C

Warranty: Six Months

Engine Tools

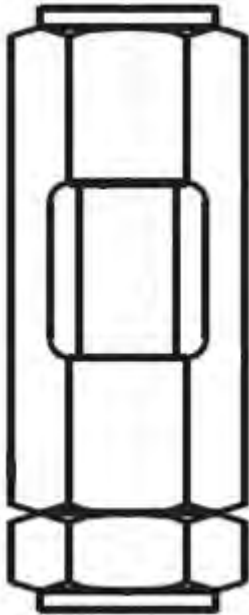

- Used to view fuel passing through fuel line during priming on engines
- Also used to inspect fluid clarity for other applications
- Used in applications where a higher pressure capacity is required

### Reference:

SEBF8327, RENR9343

Specifications	
Dimensions	27 x 108 mm (1.06 x 4.25 in)
Weight	.06 kg (.13lbs)
Materials	Brass, Buna N Seals, Borosilicate Sight
Port Size	3/8"-18 NPT
Maximum Working Pressure	2930kPa (425 psi)
Maximum Working Temperature	65.6° C (150° F)

Part Number	Description
377-5782	High Pressure In-Line Flow Sight

## 9U-6872 In-line Flow Sight

Model: 777C, 785B, 789B, 793B, D11N, and 994

Warranty: Six Months

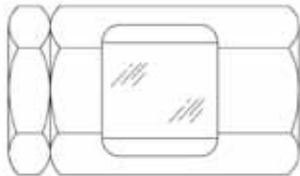

- Used to view fuel passing through fuel line during priming on 3500 EUI Engines
- Also used to inspect fluid clarity for other applications

Length	75 mm (3.0 in)
Width across flats	35.05 mm (1.380 in)
Port size	1/2 - 14 NPTF
Construction	brass with Buna N seals
Maximum working temperature	93° C (200° F)
Maximum working pressure	345 kPa @ 21° C (50 psi @ 70° F)

Part Number	Description
9U-6872	In-line Flow Sight

## 185-3630 Filter Strap Wrench

Model: Cat® Engines

Warranty: Six Months



- Provides quick, efficient service when removing or installing all spin-on type fuel and oil filters
- Capable of applying higher torques required on larger filters without denting filter can

Item	Part Number	Description
1	6H-7378	Retaining Ring
2	1P-0551	Spring Pin
3	2P-8253	Strap
--	185-3630	Filter Strap Wrench Assm. <sup>1</sup>

(Continued)

## 185-3630 Filter Strap Wrench (Continued)

Model: Cat® Engines

Warranty: Six Months

<sup>1</sup>Warranty: Six Months

## Special Sockets for Fast Fill Fuel System Adapters

Model: Cat® Engines

Warranty: Six Months

Item	Part Number	Description
1	3P-2230	Socket

**Fast-fill fuel system adapters require special sockets for their removal and installation**

- 3P-2230 Socket used for Wiggins Adapter
- To remove and install Buckeye Adapter, order HG-190 Socket from Apex Machine and Tool Co, 7659 S. Western Avenue, Chicago, IL 60620

Item	Part Number	Description
2	HG-190	Socket



## 369-2607 Digital Dial Indicator

Model Usage: 3116, 994

Warranty: Six Months

- Replaces 1U-8869 Digital Dial Indicator
- Intended primarily for engine fuel system and governor adjustments but can be used in virtually any location or application that requires an indicator
- Can be used for any rack setting that is not greater than 12 mm (0.47 in); only a few engines, such as some 5.4 bore V engines, have rack settings that are greater than 12 mm (0.47 in)
- Especially useful for timing adjustments on engines with unit injectors
- Has 9.52 mm (3/8 in) stem and can be used with standard 9.52 mm (3/8 in) collets and brackets
- Can directly replace both inch and metric mechanical indicators if measuring task does not require more travel than 369-2607 is capable of; replaces 6V-3075, 6V-6106, 9M-9268, discontinued 8S-2283, and 9S-0215 indicators in most applications
- Digital (LED) display which reads in either millimeters or inches —readings displayed to nearest 0.01 mm (0.0005 in)
- Total travel of 12.7 mm (0.50 in) and can be zeroed at any plunger position which allows 369-2608 to read either positive or negative in either direction of plunger travel
- Can be pre-set to read a specific number at a particular plunger position
- Pre-set feature especially useful for measuring or setting timing dimension on engines with unit injectors (1.1 liter, 3500, 3600); pre-set feature allows indicator to be set (off engine) to set gauge dimension; when indicator and timing fixture placed on injector, actual timing dimension is displayed
- Entire head, with display, can be rotated 270° for ease of readability
- Power is supplied by two SR 44 batteries contained in indicator
- Additional features, such as use with remote printer and computers, described in instructions packaged with indicator
- 369-2607 Indicator is similar in several ways to discontinued 8T-1000 Digital Position Indicator but should not be considered interchangeable; discontinued 8T-1000 Indicator has full 25 mm (1 in) travel, remove readout and dampened transducer which allows it to be used for running rack reading; 369-2607 is less tolerant of vibration than discontinued 8T-1000 and is intended primarily as a versatile replacement for mechanical indicators
- Service Part: 3S-3268 Point

(Continued)

## 369-2607 Digital Dial Indicator (Continued)

Model Usage: 3116, 994

Warranty: Six Months



Part Number	Description
369-2607	Digital Indicator

## FT2650 Vacuum Fuel Cap

Model: 525, 527, and 545 Skidders

Warranty: None

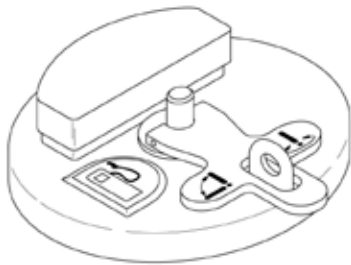

- Used to minimize fuel loss when fuel system must be disassembled
- Special vacuum cap assembly can be installed in place of fuel filler cap
- Applying air pressure to 5P-0306 Vacuum Transducer produces a continuous vacuum in tank
- With 3 to 5 kg/cm<sup>2</sup> (50 psi) air pressure applied, transducer uses 4.65 C.F.M. of compressed air and pulls 8.75 C.F.M. of vacuum flow at 0 kg/cm<sup>2</sup> (0 psi)
- Maximum of 406 mm (16 in) Hg is pulled at 5.6 kg/cm<sup>2</sup> (80 psi) or 254 mm (10 in) Hg at 3 to 5 kg/cm<sup>2</sup> (50 psi)

## 171-1085 Bolt Remover Kit, 171-1088 Torque Screw Locknut Wrench, 171-1089 Idle Adjustment Locknut Wrench

### Essential Tool

Model: 3054 and 3056 Engines with Stanadyne Pumps

Warranty: Six Months

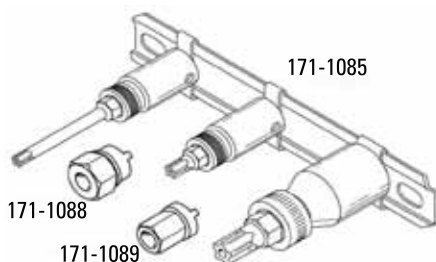

#### 171-1085 Bolt Remover Kit

- Replaces discontinued 154-7151 Bolt Remover Kit
- Used to remove and install tamper resistant bolts on Stanadyne fuel injection pump and aneroid shield
- Used with 1/4 and 3/8 inch square drive ratchets
- Used on 5YS, 7MS, 2PW, 3GW serial number engines
- Includes longer 15IPR Torx bit for adjusting torque and idle screw

#### 171-1088 Torque Screw Locknut Wrench

- Used to loosen and tighten the torque screw locknut
- Used with 1/2 inch open end wrench and 1 1/2 inch long 15IPR Torx bit

#### 171-1089 Idle Adjustment Locknut Wrench

- Used to loosen and tighten the idle adjustment locknut
- Used with open end wrench and screw driver

(Continued)



**171-1085 Bolt Remover Kit, 171-1088 Torque Screw Locknut Wrench, 171-1089 Idle Adjustment Locknut Wrench (Continued)**

**Essential Tool**

Model: 3054 and 3056 Engines with Stanadyne Pumps  
 Warranty: Six Months

**NOTE:**

Use of these tamper resistant fastener tools is subject to Environmental Protection Agency (EPA) regulations. Read warning sheet included with each kit before using these tools.

Part Number	Description
171-1085	Bolt Remover Kit
171-1088	Torque Screw Locknut Wrench
171-1089	Idle Adjustment Locknut Wrench

**173-9774 Bolt Remover**

**Essential Tool**

Model: 3054 Engine, serial number 5HK Used in 914G and 1T14G  
 Warranty: Six Months

Part Number	Description
173-9774	Bolt Remover

- Used to remove and install tamper resistant fasteners used on fuel injection pump access cover
- Hex shank bit fits standard 3/8 inch hex socket
- Use of this tool is subject to EPA regulations (sale of this tool is intended for internal Cat® Dealer use by qualified mechanics)
- Fastener torque: 22 N·m (16 ft·lb)

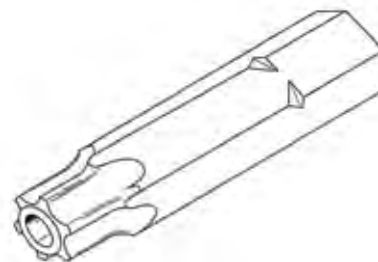

**Overhaul Tools for Discontinued 144-0835 High-Pressure Pump**

**Essential Tool**

Model: 3408E and 3412E HEUI Engines (7PR, 4CR)  
 Warranty: None

- Used to overhaul discontinued 144-0835 High Pressure Oil Pumps

**Reference**

REHS0192, Special Instruction

Item	Part Number	Description
1	FT2606	Yoke Fixture
2	FT2607	Bearing Press Tool (2 required)
3	FT2608	Rear Bearing Installation Tool
4	FT2609	Valve Block Positioning Tool
5	FT2610	Front Bearing Remover
6	FT2611	Front Bearing Support (HEUI)
7	FT2612	Rear Bearing Remover

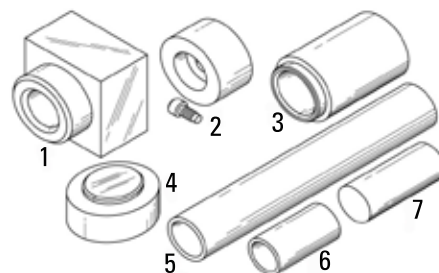

## 342-9517 Pry Bar

### Essential Tool

Model: C9 Engines

Warranty: Six Months

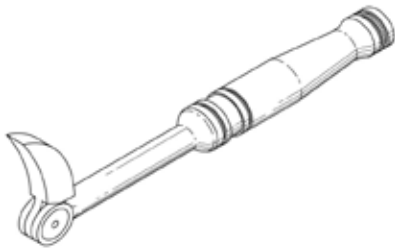

- Used to aid in removal of fuel injectors
- Provides leverage to remove injectors without damage
- Indexable tip allows adjustment to best fit each injector
- Tip can be locked at 17 incremental angles of 15 degrees
- Allen wrench (dealer supplied) used to lock claw into desired position
- Black oxide coated to resist corrosion

Handle length	304.8 mm (12.0 in)
Approximate diameter	12.7 mm (.500 in)
Approximate tip width	15.87 mm (.625 in)

Part Number	Description
342-9517	Pry Bar

## 369-4007 Bearing Driver

Model Usage: All C175 Engines

Warranty: Six Months

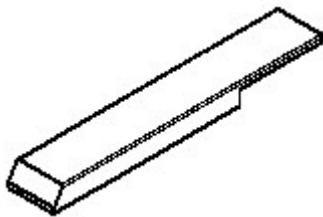

- Used to remove and install main bearings in C175 Engine
- Replaces cancelled 284-8228 Main Bearing Driver
- Made from high-strength Teflon (1E1581) to prevent damage to bearing and bearing seat

Item	Part No.	Description
1	369-4007	Bearing Driver

## 369-4008 Piston Tool Kit

Model Usage: All C175 Engines

Warranty: Six Months

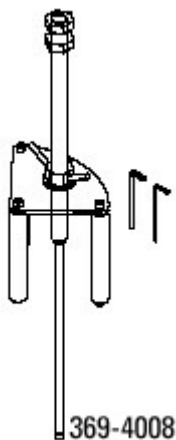

- Used to raise the piston for inspection, removal, or installation of C175 connecting rod bearings

Item	Part No.	Description
1	369-4008	Piston Tool Kit

### 372-5215 High Pressure Rail Block off Plugs

Model Usage: CT660 Truck

Warranty: Manufacturer's

- Used to test high pressure fuel system for leaks
- 6 pieces per set

Specifications	
Weight	0.14 lb per piece (0.90 lb complete set)
Size	1.15 x .875 in per piece
Material	Steel

Part Number	Description
372-5215	High Pressure Rail Block off Plugs

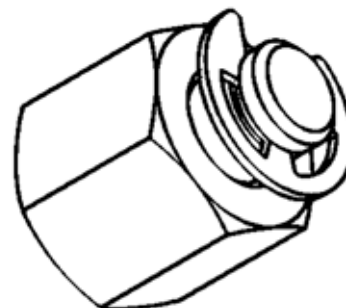

### 372-5239 Fuel Pressure Gauge

Model Usage: CT660 Truck

Warranty: Manufacturer's

- Used to measure fuel pressure, take a fuel sample and check for aerated fuel.

Specifications	
Dimensions	228.6 x 162.6 x 50.8 mm (9.0 x 6.4 x 2.0 in)
Weight	.48 kg (1.05 lb)

Part Number	Description
372-5239	Fuel Pressure Gauge



### 372-5240 Fuel Test Fitting

Model Usage: CT660 Truck

Warranty: Manufacturer's

- Used to connect fuel/oil pressure test coupler to fuel fitting to measure fuel pressure of fuel inlet restriction
  - When measuring fuel inlet restriction, fitting installed at diagnostic port (inlet side) of filter housing
  - When measuring fuel pressure, fitting can be installed in fuel rail instead of Schrader valve

Specifications	
Dimensions	50.8 x 12.7 x 12.7 mm (2.0 x 0.5 x 0.5 in)
Weight	.05 kg (.1 lb)

Part Number	Description
372-5240	Fuel Test Fitting

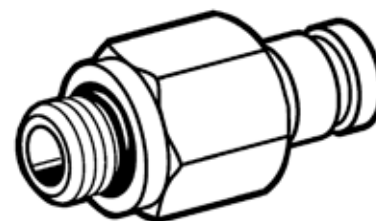

## 372-5258 Fuel Filter Wrench

Model Usage: CT660 Truck

Warranty: Manufacturer's



- Used to loosen the top collar on Fuel Pro 382 models when replacing fuel filter, cap seal and vent cap seal.
- Tool should not be used to tighten the collar after replacement
- Rust free metal with cushion grip handle

Specifications	
Dimensions	391 mm long
Weight	0.25 kg (0.55 lb)

Part Number	Description
372-5258	Fuel Filter Wrench

## 373-4717 Injector Remover

Model Usage: CT660 Truck

Warranty: Manufacturer's

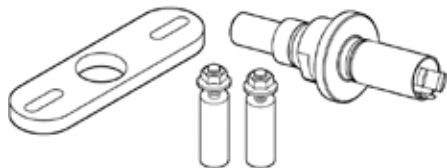

- Used to remove injectors from cylinder head

Specifications	
Dimensions	218.4 x 132.1 x 116.8 mm (8.6 x 5.2 x 4.6 in)
Weight	2.9 kg (6.5 lb)

Part Number	Description
373-4717	Injector Remover

## 373-4719 Fuel Line Disconnect

## 373-4721 Fuel Line Disconnect

Model Usage: CT660 Truck

Warranty: Manufacturer's

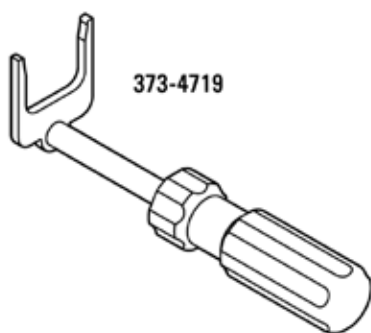

373-4719

- Used to release the locking mechanism to allow fuel line removal

Specifications		
	373-4719	373-4721
Dimensions	127 x 38.1 x 38.1 mm (5.0 x 1.5 x 1.5 in)	127 x 38.1 x 38.1 mm (5.0 x 1.5 x 1.5 in)
Weight	0.06 kg (0.13 lb)	0.06 kg (0.13 lb)

Part Number	Description
373-4719	Fuel Line Disconnect
373-4721	Fuel Line Disconnect

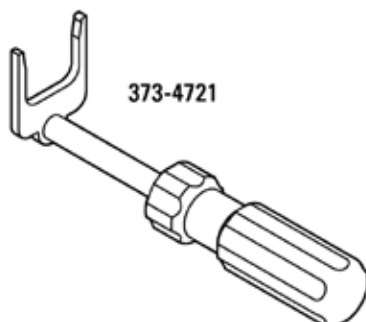

373-4721

## 373-4723 Injector Installer

Model Usage: CT660 Truck

Warranty: Manufacturer's

- Used to manually install injector into cylinder head

Specifications	
Dimensions	50.8 x 25.4 mm (2.0 x 1.0 in)
Weight	0.01 kg (0.4 oz)

Part Number	Description
373-4723	Injector Installer

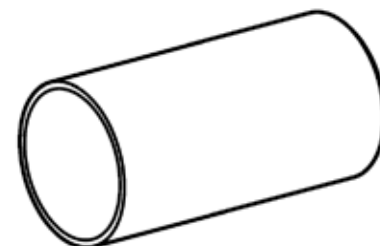

## 373-4727 Fuel Line Restriction and Aeration Tool

Model Usage: CT660 Truck

Warranty: Manufacturer's

- Used to assist in diagnosis of fuel loss or degradation

Specifications	
Dimensions	340.4 x 127 mm (13.4 x 5.0 in)
Weight	0.64 kg (1.4 lb)

Part Number	Description
373-4727	Fuel Line Restriction and Aeration Tool

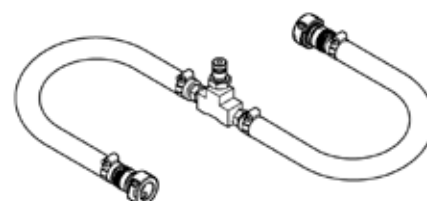

## 373-4728 High Pressure Fuel Rail Return Tester

Model Usage: CT660 Truck

Warranty: Manufacturer's

- Used to properly test the high pressure return line
- 17 mm (.70 in)

Specifications	
Dimensions	203.2 x 152.4 x 25.4 mm (8 x 6 x 1 in.)
Weight	0.077 kg (0.2 lb.)

Part Number	Description
373-4728	High Pressure Fuel Rail Return Tester

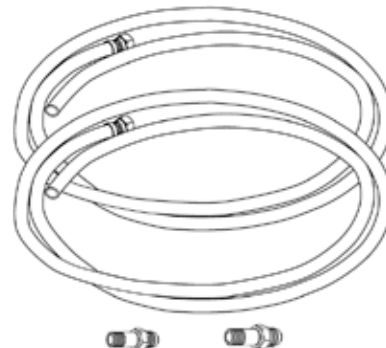

## 373-4730 Air & Fuel System Caps

Model Usage: CT660 Truck

Warranty: Manufacturer's

- Used to prevent dirt and debris from entering system during service

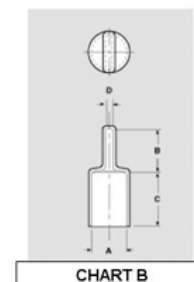
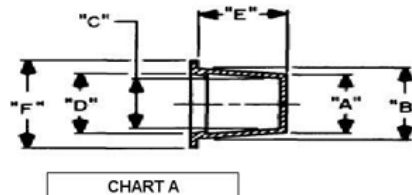

(Continued)

# Fuel System Repair and Adjust







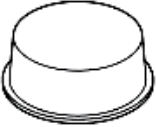

## 373-4730 Air & Fuel System Caps (Continued)

Model Usage: CT660 Truck

Warranty: Manufacturer's



Part Number	Description
373-4730	Air & Fuel System Caps

### Fuel System Caps

	TYPE	Dim A	Dim B	Dim C	Dim D	Dim E	Dim F	CHART
	Tapered cap/plug	4.990	5.200	4.920	5.100	1.000	5.630	A
	Tapered cap/plug	4.090	4.320	4.010	4.240	1.250	4/620	A
	Tapered cap/plug	0.690	0.788	0.628	0.726	0.560	0.940	A
	Tapered cap/plug	0.815	0.930	0.753	0.868	0.625	1.090	A
	Tapered cap/plug	0.964	1.090	0.901	1.025	0.750	1.250	A
	Tapered cap/plug	0.390	0.456	0.327	0.394	0.380	0.590	A
	Tapered cap/plug	1.094	1.215	1.031	1.152	0.750	1.410	A
	Tapered cap/plug	2.760	2.990	2.685	2.947	1.000	3.130	A

**Air System Caps**

**Chart B**

	TYPE	Dim A	Dim B	Dim C	Dim D	Dim E	Dim F	CHART
	Cap with Pull-Tab	0.475	0.625	1.000	0.125	1.625		B
	Cap with Pull-Tab	0.427	0.625	1.000	0.125	1.625		B

Engine Tools

**373-4731 Fuel Injector Cups**

Model Usage: CT660 Truck

Warranty: Manufacturer's

- Used to protect and prevent dirt and debris from damaging injectors while out of engine

Specifications	
Dimensions	304.8 x 203.2 x 76.2 mm (12 x 8 x 3 in.)
Weight	0.23 kg ( 0.5 lb.)

Part Number	Description
373-4731	Fuel Injector Cups

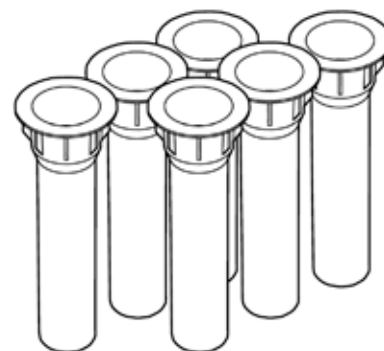

**373-4734 Fuel Block Off Tool**

Model Usage: CT660 Truck

Warranty: Manufacturer's

Specifications	
Dimensions	50.8 x 12.7 x 12.7 mm (2 x .5 x .5 in)
Weight	0.1 kg (0.2 lb)

Part Number	Description
373-4734	Fuel Block Off Tool

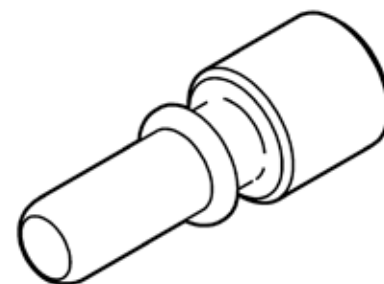

**373-4735 Fuel Line Coupler**

Model Usage: CT660 Truck

Warranty: Manufacturer's

- Used for in-line testing and diagnostics during tool usage

Specifications	
Dimensions	45.7 x 106. x 20.3 mm (1.8 x 4.2 x 0.8 in)
Weight	0.1 kg (0.2 lbs)

Part Number	Description
373-4735	Fuel Line Coupler

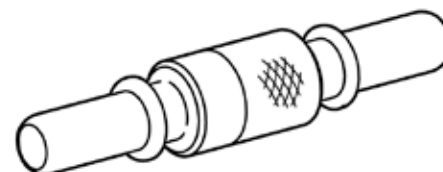

## 380-8305 Timing Case Cover Alignment Tool

Model Usage: C4.4

Warranty: Six Months

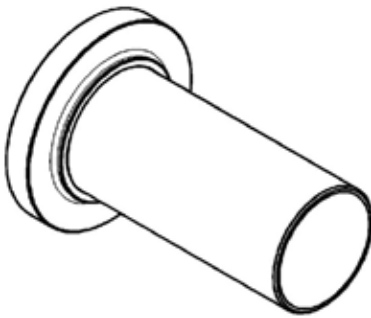

- Used to correctly align pressed steel timing case cover to the timing case

Specifications	
Dimensions	150 x 95 x 95 mm (5.9 x 3.7 x 3.7 in)
Material	Steel
Weight	0.77 kg (1.7 lb)

Part Number	Description
380-8305	Timing Case Cover Alignment Tool

## 375-2691 Air in Fuel Sight Gauge

Model Usage: C7.1, C6.6, C4.4

Warranty: Six Months



- Used in test procedures to view air in fuel
- Quick disconnects for easy insertion and removal
- Used to temporarily replace low-pressure fuel line to make observation

Part Number	Description	Dimensions
375-2691	Air in Fuel Sight Gauge	1263 x 119 x 19 mm (50 x 4.7 x 0.7 in)



Pistons, Rings and Connecting Rods

**5P-3519 Piston Ring Groove Gauge**

Model: Cat® Engines  
 Warranty: Six Months

- Used to check top and intermediate ring grooves (rectangular) to determine piston reusability
- Includes 5 plug-type gauges that cover all widths of top and intermediate grooves (gauges numbered 1 through 5)
- Attached tag identifies gauges and their use

**Reference**

SEBF8049, Guideline for Reusable Parts

Items Included	Description
Form SEHS7758	Instruction Card



Item	Part Number	Description
1	5P-4227	Tag Holder, Form SEES5544 Instruction Card
2	6V-3191	Gauge (#2)
2	6V-3194	Gauge (#5)
2	6V-3190	Gauge (#1)
2	6V-3192	Gauge (#3)
2	6V-3193	Gauge (#4)
--	5P-3519	Piston Ring Groove Gauge
<b>Also available for 3500 Engines</b>		
--	4C-4519	Gauge Assembly (not part of 5P-3519)

**342-6241 Piston Gauge (3600 Diesel)**

**Essential Tool**

Model: 3600 Engine  
 Warranty: Six Months

Part Number	Description
342-6241	Piston Gauge (3600 Diesel)

- Used on 197-6700 and 314-2700 Pistons
- Used to determine piston crown to skirt torque
- Used to indicate piston wear and reuse capability
- Used to measure angle on bolt that holds piston crown to piston skirt
- Made from aluminum with red anodizing — etched markings appear gray for better visibility
- Marked at 0, 30, 45, 60, and 90 degrees

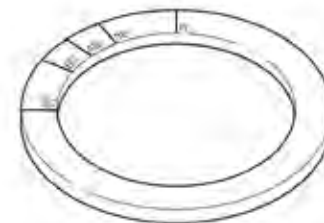

## 1U-6431 Gauge Group

Model: 3406B

Warranty: Six Months



- Used for checking ring groove wear on 7C-0473, 7C-3496 and 7W-3668 Pistons found in some 3406B Truck Engines beginning with 1985 production
- Replaces discontinued 8T-3150 Gauge Group; consists of 6 gauges from 8T-3150 plus 1U-6432 Gauge and revised SEES5678-02 Instruction Card; 1U-6432 and SEES5678-02 Instruction Card can be used to upgrade existing 8T-3150 Gauge Group

Item	Part Number	Description
1	8T-3144	Gauge Assembly
2	8T-3145	Gauge Assembly
3	8T-3146	Gauge Assembly
4	8T-3147	Gauge Assembly
5	8T-3148	Gauge Assembly

Item	Part Number	Description
6	8T-3149	Gauge Assembly
7	1U-6432	Gauge Assembly
8	5P-4227	Tag Holder, Form SEES5544 Instruction Card
9	6V-3196	Gauge Assembly
--	1U-6431	Gauge Group

### Reference

Service Magazine, June 1, 1987, page 15

Truck Engine News, May 1987, Page 8, "Use Correct Pistons and Rings for 3406B Truck Engines"

### Description

SEES5678-02 Instruction Card

1U6431 KEYSTONE PISTON RING GROOVE GAUGE GROUP

BORE SIZE	TYPICAL ENGINES	GAUGES TO USE	
		TOP GROOVE	INTERMEDIATE GROOVE
4.75"	3300, 1674	B	B
5.4"	D343, 1603	D	D
5.4"	D346, D348, D349	B	A
5.4"	3406, 3408, 3412 (With 1/8" top ring)	A	A
5.4"	3406, 3408, 3412 (With larger top ring)	E	A
5.4"	3406B Truck (1985-UP)	G	A
5.75"	D342	C	C
6.25"	D353	C	C
170 mm	3508, 3512, 3516	F	F



CHECK GROOVES AT TWO POSITIONS ON MAJOR DIAMETER, 90° FROM EACH PIN BORE. BODY OF GAUGE MUST ALWAYS BE OVER CAST BAND (SEE DRAWINGS).

DO NOT USE AGAIN

### 9U-5931 Piston Ring Groove Gauge

Model: 3114 and 3116 Engines

Warranty: Six Months

Part Number	Description
9U-5931	Piston Ring Groove Gauge

- Used to measure piston ring groove
- Checks top and intermediate ring grooves to determine piston reusability
- Used on one-piece aluminum pistons: 7C-5668, 9Y-7452, 9Y-5536, 7E-1298, 7E-3428, 7E-3578
- Dimensions: 12.7 x 9.52 x 47.62 mm (0.5 x 0.37 x 1.87 in)



### Piston Ring Groove Gauge Groups

#### Essential Tool

Model: See below

Warranty: Six Months

- Used to quickly and accurately check top ring groove pistons for wear (checks top ring groove only)
- Uses a simple Go/No-Go design (if piston passes through gauge it cannot be reused)
- Improves reliability of inspection and reduces inspection time
- Gauge repair and recalibration done only by manufacturer (damaged blades can be replaced and adjustable design allows gauge to be easily recalibrated)

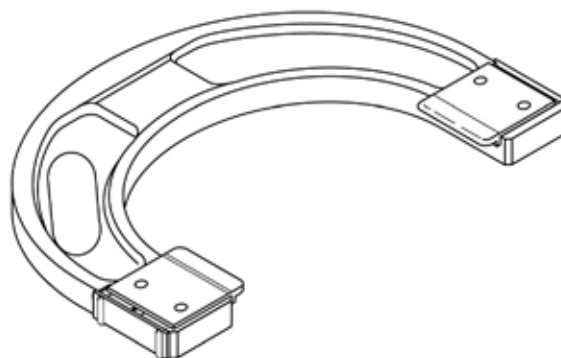

#### References

NEHS0775 Tool Operating Manual

NEHS0834 Tool Operating Manual

NEHS0909 Tool Operating Manual

SEBF8059 Inspection Procedures and Specifications for Pistons

Note: SEBF8059 also specifies the correct gauge for a given piston part number

Piston Ring Groove Gauges (Horseshoe Type)		
Part Number	Engine Model	Manufacturer Recalibration
4C-8164	3114 and 3116	No
186-0190	3126	Yes
4C-8165	3176	No
4C-8168	3300	No
4C-8169	3400	No
325-8422	3406	Yes
325-8418	3406 to 3412	Yes
132-4389	3406E	No
9U-7360	3500 with Keystone Rings	No

Piston Ring Groove Gauges (Horseshoe Type)		
Part Number	Engine Model	Manufacturer Recalibration
246-1176	3500A and B with Monotherm Pistons	Yes
204-8041	3500HD and 3524B	Yes
208-7632	C12, C13, and 3196	Yes
208-7636	C16	Yes
325-8425	C18 and 3412D	Yes
325-8419	C18 to C30	Yes
325-8423	C32	Yes
325-8420	C7	Yes
325-8417	C9	Yes
325-8421	C9	Yes

## Piston Ring Groove Gauges

Model: 3500B Engines: Serial Numbers 7TR, 2GR, and 7RN

Warranty: Six Months

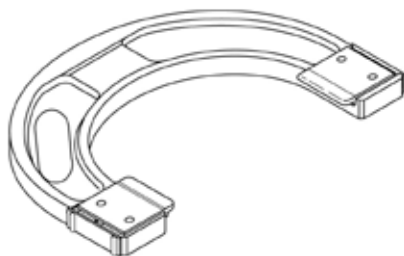

- Used to quickly and accurately check 278-0247 Monotherm Piston Ring Grooves for wear
- Uses a simple Go/No-Go design (if piston passes through gauge it cannot be reused)
- Improves reliability of inspection and reduces inspection time
- Gauge repair and recalibration done only by manufacturer (damaged blades can be replaced and adjustable design allows gauge to be easily recalibrated)

Part No.	Description	Used On
329-2630	Ring Groove Gauge	top piston ring groove
329-2631	Ring Groove Gauge	second piston ring groove

### References

NEHS0909, Tool Operating Manual

SEBF8059, Procedure to Clean and

Inspect One-Piece Pistons

## Piston Ring Groove Gauges

Model: C175 Engines

Warranty: Six Months

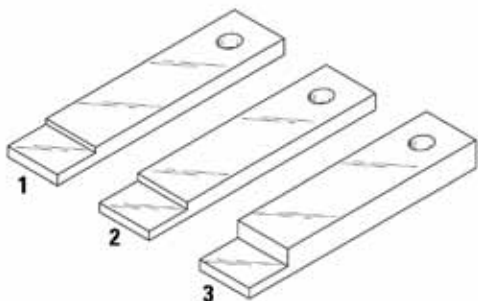

- Used to check piston ring groove wear to determine usability of C175 Engine piston
- Simple to use Go/No-Go design. If the scribe line is visible, then the piston ring groove is good. If the line is not visible, then the piston is nonreusable.
- Three separate gauges check all three piston ring grooves
- Gauges clearly marked with TOP RING, SECOND RING, and OIL RING for easy identification
- Made from heat treated steel for wear resistance
- Size (length x width): 75 x 19 mm (3.0 x 0.75 in)
- Hole in each gauge [0.125 mm (0.250 in)] allows gauges to be grouped together on a tether

Item	Part Number	Description
1	327-8644	Ring Groove Gauge (top ring)
2	327-8645	Ring Groove Gauge (second ring)
3	327-8646	Ring Groove Gauge (oil ring)

## FT1022 Gauge

Model: 1100, 3100

Warranty: None

- Used to determine if correct pistons and crankshaft have been installed in 1100 and 3100 Series Engines
- Material: SAE 1020 steel

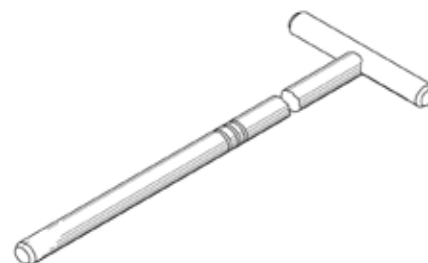

Engine Tools

## 1U-7616 Compressor Group

Model: 3500

Warranty: Six Months

- Band-type piston ring compressor used for servicing 3500 Series Engines
- Similar to former band-type 6V-4021 Ring Compressor Group — improvements allow 1U-7616 to provide better seating of band assembly on cylinder liner to minimize possibility of ring breakage
- Has lock to secure compressed piston rings in place on piston
- Two handles for easier handling of piston, rings and rod assembly



Item	Part Number	Description
1	1U-7615	Band Assembly
2	6V-4027	Handle Assembly
--	1U-7616	Compressor Group

## 329-8877 Piston Ring Compressor Tool Group

Model: 3600 Engines

Warranty: Six Months

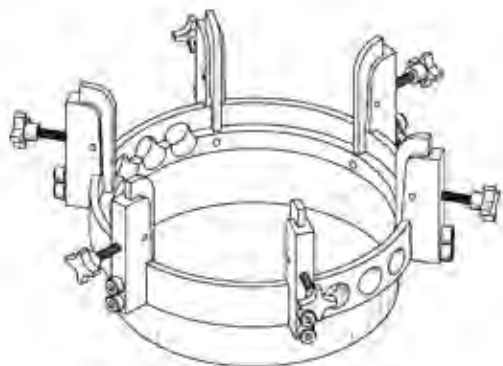

- Used to compress piston rings for piston installation on 3600 Engines (fits into top of cylinder liner and guide piston into cylinder)
- Used with overhead lifting device to lower piston/connecting rod assembly into cylinder
- Guide arms hold rings in ring grooves to prevent liner damage during piston insertion
- Guides are hardened (RKW C58-62) and black oxide coated for long wear and resistance to corrosion
- Tool weight: 11.3 kg (25 lbs)

### Application Procedure

1. Fully open all six adjustable guide arms.
2. Place tool over piston opening in cylinder block.
3. Lower piston until piston rings aligned with guide arms.
4. Lubricate piston rings and grooves.
5. Turn adjustment knobs to press rings into piston grooves.
6. Lower piston assembly into cylinder block.

Part Number	Description
329-8877	Piston Ring Compressor Tool Group
Service/Repair Parts	
329-8876	Adjustable Guides
8T-9515	Socket Head Bolts
5M-2894	Washer

## 255-8897 Ring Compressor Group

### Essential Tool

Model: C175 Engine

Warranty: Six Months

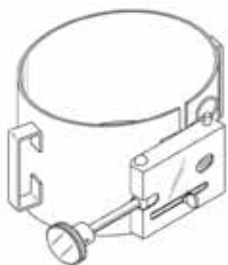

- Used to compress piston rings

### Reference

REN7466, C175 Engine Disassembly and Assembly Manual

Part Number	Description
313-4079	Band Assembly (not serviced)

Part Number	Description
255-8897	Ring Compressor Group
Service/Repair Parts	
313-4079	Band Assembly (not serviced)
6V-4027	Handle Assembly
142-8546	Set Screw

### Piston Ring Expanders

Model: Cat® Engines  
 Warranty: Six Months

- Used to easily and safely remove and install piston rings
- When removing or installing piston rings without suitable tool, rings apt to be broken or overstressed so they no longer fit cylinder wall properly



Engine Bore	Expander
114.3 mm (4.50 in)	5F-9059
120.7 mm (4.75 in)	7S-9470
130.2 mm (5.13 in) <sup>1</sup>	4C-3601
137.2 mm (5.40 in)	7M-3978
139.7 mm (5.50 in)	149-7179
146.1 mm (5.75 in)	7B-7974
158.8 mm (6.25 in)	5H-9621
170 mm (6.69 in)	271-0498
175 mm (6.89 in)	271-0504
280 mm (11.02 in)	271-0505
300 mm (11.81 in)	4C-8995

<sup>1</sup> Also available in Engine Bore: 133.4 mm (5.25 in)

### Piston Ring Compressors

Model: Cat® Engines  
 Warranty: Six Months

- Simple, but practical, one-piece piston ring compressors save time and prevent damage to rings when installing pistons in older engines
- Taper on inside is ground to a smooth surface so rings slide through easily
- 2B-8184 and 6H-4140 Compressors no longer available but may be fabricated by requesting drawings for FT1400 and FT1401 Compressors
- Scissors-type piston ring compressors used on more current Cat® engines; much easier and faster to use; ring breakage and injury to fingers practically eliminated



Typical One-Piece Ring Compressor

Engine Bore	Compressor
146.10 mm (5.75 in)	2B-8184 {1} or FT1400
158.80 mm (6.25 in)	6H-4140 {1} or FT1401
{1} Discontinued	

Engine Bore	Compressor
108 mm (4.25 in)	1U-6684

### Scissors Type Ring Compressor

Engine Bore	Compressor
<b>Scissors Type Ring Compressor</b>	
105 mm (4.13 in)	187-1462
114.30 mm (4.50 in)	5P-3524
120.70 mm (4.75 in)	5P-3525
125 mm (4.92 in)	161-4163
130.10 mm (5.12 in)	161-4164
137.20 mm (5.40 in)	5P-3526
139.70 mm (5.50 in)	149-7180
145 mm (5.71 in)	200-3914

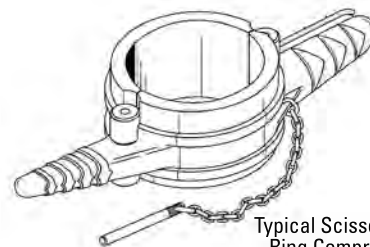

Typical Scissor-Type Ring Compressor

(Continued)

## Scissors Type Ring Compressor (Continued)

Engine Bore	Compressor
<b>Scissors Type Ring Compressor (Continued)</b>	
146.10 mm (5.75 in)	5P-3527
158.80 mm (6.25 in)	5P-3528
<b>Scissors Type Ring Compressor (3126 and 3126B Engines)</b>	
110 mm (4.33 in)	173-5529
<b>Scissors Type Ring Compressor (C9.3 Engines)</b>	
114.85 mm (4.52 in)	363-4046

## Piston Ring Expansion Pliers

Model: 3600 Engines  
Warranty: Six Months

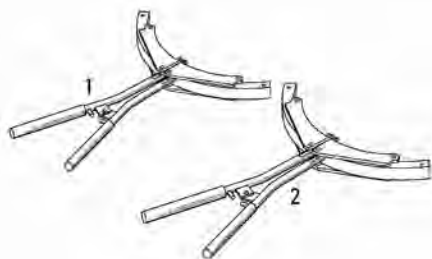

- Used to remove and install piston rings
- Will not damage or deform piston rings or piston
- Designed to the correct piston ring diameter
- Handle design provides leverage to expand piston ring

Item	Part Number	Description	Sized For
1	318-3117	Ring Expanders	280 mm (11.0 in) rings
2	318-4874	Ring Expanders	300 mm (11.8 in) rings

## 1U-6683 Expander

### 4C-3601 Ring Expander, 1U-6684 Compressor

Model: 3114, 3116, 3176  
Warranty: Six Months



- 1U-6683 Expander used to expand piston rings to install them on piston on 3114 and 3116 Engines
- 4C-3601 Ring Expander used to remove and install piston rings on 3176 Engine
- 1U-6684 Compressor used to compress piston rings to install piston into cylinder on 3114, 3116 and 3176
- 1U-6684 Compressor capacity: 76.2 mm (3 in) to 127.0 mm (5 in)

#### References

SENR3582, Specification Module  
SENR3583, System Operation Testing and Adjusting  
SENR3611, Disassembly and Assembly Manual  
SEHS8868, Special Instruction, operation

Part Number	Description
1U-6683	Expander
1U-6684	Compressor
4C-3601	Ring Expander



**FT2984 Piston Pin Installer**

**FT2985 Piston Pin Installer**

Model: 3500A and B; 3500B HD Engines

Warranty: None

- Used to properly align piston crown, piston skirt, and connecting rod bores prior to installing the piston pin
- Eliminates damage to piston components during installation
- FT2984 is used on 3500B High Displacement Engines and FT2985 is used on 3500A and B Standard Stroke Engines
- To use, place piston pin on installer; align crown, skirt, and connecting rod bores; coat all mating surfaces with clean engine oil; push large end of tool through bores until piston pin is in place; remove installer
- Made from Polyurethane (95 Durometer)



**9U-5945 Rod Locating Group**

**9U-5948 Expanding Segment Group (1.1)**

Model: 3114 and 3116 Engines

Warranty: Six Months

- Aligns 3114 and 3116 connecting rods in discontinued 5P-3550 Connecting Rod Boring Machine prior to boring rod eye bushings
- 5P-3550 Connecting Rod Boring Machine is discontinued and not available from Cat®

**9U-5948 Expanding Segment Group (1.1):**

- Consists of three 50.8 mm (2 in) long segments of split collet and an O-ring (segments sold only as a group)
- Sold separately — not part of 9U-5945 Rod Locating Group

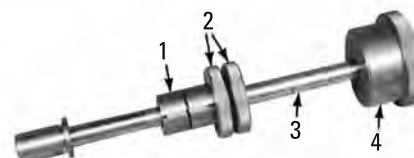

Item	Part Number	Description
1	9U-5948	Expanding Segment Group (consists of 3 segments and one 7T-0507 O-ring)
--	9U-5945	Rod Locating Group
<b>9U-5945 Rod Locating Group includes:</b>		
2	9U-5944	Expander Nut (2) (not serviced)
3	9U-5943	Bushing Locating Rod
4	9U-5946	Bushing (not serviced)
Not shown	9U-5947	Expander Cone (not serviced)

# Pistons, Rings and Connecting Rods

## 9U-5917 Pin Mandrel, Bushing Out

## 9U-5918 Pin Mandrel, Bushing In

Model: 3114 and 3116 Engines

Warranty: Six Months



- Used to check connecting rods
- Provides accurate method for measuring bore misalignment and rod distortion
- Rod can be checked before and after rebuild with rod eye bushing in or out
- Length: 140 mm (5.5 in)
- Composition: steel

Part Number	Description
9U-5917	Pin Mandrel, Bushing Out
9U-5918	Pin Mandrel, Bushing In

## Tools for Connecting Rod Pin Bearing Removal and Installation

Model: Cat® Engines

Warranty: Six Months

- Used to remove and install both tapered and standard connecting rod pin bearings
- Basic 5P-8639 Press Group required for all engines in addition to other tools for each family of engines; refer to table for hydraulic service tools for use with 5P-8639 Press Group
- 5P-8655 Tool Group required for current engines with standard rods

Refer to table below to select appropriate hydraulic pump and for comparison of hydraulic pump press time.

Hydraulic Service Tools for use with 5P-8639 Press Group	
Description	Qty.
Hydraulic Pump (Electric or Hand)	1

Hydraulic Service Tools for use with 5P-8639 Press Group					
Part Number	Description	Press Time Seconds	Loading and Unloading Time Seconds	Total Time Seconds	Qty.
2P-5500	(230V) Electric Hydraulic Pump	10 - 15	45	55 - 60	--
2P-5550	(115V) Electric Hydraulic Pump	10 - 15	45	55 - 60	--
3S-6224	Pump Group - Hydraulic (115V)	3 - 5	45	48 - 50	--
8S-8033	Pump Grp - Hydraulic (230V)	3 - 5	45	48 - 50	--
Hydraulic Service Tools for use with 5P-8639 Press Group					
1P-2375	Coupler Assembly Quick Connective (Male)	--	--	--	1
1P-2376	Coupler Assembly Quick Connective (Female) (2)	--	--	--	1
8F-0024	Hose Assembly	--	--	--	1

## Service Parts for 5P-8639 Connecting Rod Bearing Press Group (Basic)



Item	Part Number	Description
1	5P-8640	Clamp Bar
2	5P-8642	Clamp Pin
3 <sup>1</sup>	5P-9725	Cylinder Group
4 <sup>2</sup>	1P-2375	Coupler Assembly Quick Connective (Male)
4 <sup>2</sup>	1P-7437	Protective Cap
--	5P-8639	Connecting Rod Bearing Press Group

<sup>1</sup>5P-9724 Repair Kit is available

<sup>2</sup>Part of 5P-9725

**Service Parts for 5P-8655 Connecting Rod Tool Group (Standard)**

Item	Part Number	Description
1	5P-8663	Adapter
2	5P-8661	Spacer
2	5P-8662	Spacer
2 <sup>1</sup>	5P-8654	Spacer
2 <sup>2</sup>	5P-8647	Spacer
3	5P-8656	Adapter, D320 or 3204, 3208, D330 and 3300
3	5P-8657	Adapter, D330 and D330
3	5P-8658	Adapter, 1693, 3400
3	5P-8659	Adapter, D342, D353
3	5P-8660	Adapter, D353, D398
--	5P-8655	Connecting Rod Tool Group

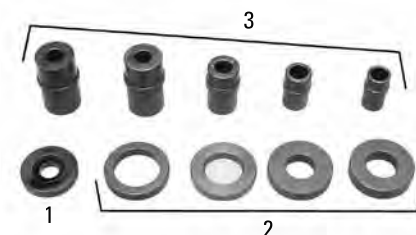

<sup>1</sup> Also in discontinued 5P-8652

<sup>2</sup> Also in 5P-8644

**Tools for Removing and Installing Tapered Connecting Rod Bearings**

Model: Cat® Engines

Warranty: Six Months

- Following is a complete list of tools required for bearing removal and installation. Use the application chart to select the tools for each engine connecting rod assembly.

Engine Model	Rod Assembly	Push Adapter	Spacer	R and L Adapter	Bar Clamp	Rod Part Number Position
D346	4N-9001	5P-8645	5P-8647	5P-8646	--	UP
D348	4N-9002	5P-8645	5P-8647	5P-8646	--	DOWN
D349	4N-4261	5P-8645	5P-8647	5P-8646	--	UP
	--	5P-8645	5P-8647	5P-8646	--	UP
	--	5P-8645	5P-8647	5P-8646	--	UP
3204	--	5P-8645	6V-4819	5P-8653	--	DOWN
3208	--	5P-8645	6V-4819	5P-8653	--	UP
3300	8N-1721	5P-8645	6V-3029	6V-2049	--	
3400	7N-3229-6	5P-8649	5P-8651	5P-8650	5P-8640	UP
	7N-3231-6	5P-8649	5P-8651	5P-8650	5P-8640	UP
	8N-1726-9	5P-8645	6V-3197	5P-8646	5P-8640	
	8N-2486-9	5P-8645	6V-3197	5P-8646	5P-8640	UP
3500	--	5P-8649	6V-3043	6V-3042	5P-8640	DOWN
6°	--	5P-8649	6V-3043	6V-3042	5P-8640	DOWN
3500	--	4C-8725	4C-8726	4C-8727	5P-8640	DOWN
10°	--					DOWN
1.1 L	--	4C-9749	4C-9751	4C-9750	--	
12.5°						

(Continued)

# Pistons, Rings and Connecting Rods

## Tools for Removing and Installing Tapered Connecting Rod Bearings (Continued)

Model: Cat® Engines

Warranty: Six Months

Engine Tools



Item	Part Number	Description
1	5P-8653	Adapter
2	6V-2049	Adapter
3	6V-4819	Spacer
4	5P-8650	Adapter
5	5P-8645	Adapter
6	5P-8646	Adapter
7	5P-8649	Adapter
8	6V-3042	Adapter
8	8T-5261	Adapter
9	6V-3043	Spacer
10	6V-3197	Spacer
11	5P-8647	Spacer
12	5P-8651	Spacer
13	6V-3029	Spacer

### 1U-6242 Pin Bushing Adapter

### 1U-6244 Spacer, 1U-6243 Push Adapter

Model: 3176 Engine

Warranty: Six Months



- Used to remove and install piston pin bearing on 9Y-1170 and 4P-2232 Connecting Rod Assemblies
- Used with 5P-8639 Press Group
- The base plate of the 5P-8639 Press Group must be modified in order to remove and install the piston pin bearing; drill and tap a 5/8-11 hole, 225.00 mm (8.858 in), from the center of the largest bore; refer to diagram

Part Number	Description
1U-6242	Pin Bushing Adapter
1U-6243	Push Adapter
1U-6244	Spacer

## Base Plate

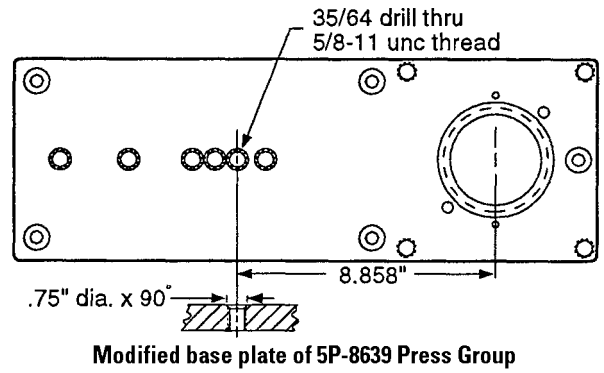

Engine Tools

### 1U-9032 Pin Bushing Adapter

### 1U-9033 Spacer, 1U-9034 Push Adapter

Model: 3406E Engine

Warranty: Six Months

- Used to remove and install connecting rod pin bearing (9Y-6054 Connecting Rod Assembly)
- Used with 5P-8639 Press Group
- Specifically designed for connecting rods with 12° taper



Part Number	Description
1U-9032	Pin Bushing Adapter
1U-9033	Spacer
1U-9034	Push Adapter

### FT1888 Slide Hammer Adapter

Model: 3208

Warranty: None

- Used with 1P-0074 Slide Hammer to install bolts
- Used to replace bolt without removing piston/rod assembly when connecting rod bolt is damaged



## Reconditioning Connecting Rod Tools

Model: Cat® Engines  
Warranty: Six Months



- Used to produce smoother surface finish (10 MU or less required) in piston pin bearing when new piston pin bearing is installed in connecting rod and 4W-7402 Piston is used
- Smoother surface finish required only for new piston pin bearings
- 8T-2841 (discontinued) and 8T-2842 Pin Mandrel used with discontinued 5P-2050 Rod Checking Fixture to check bend, twist, and center distance

### References

SMHS7366, Special Instruction  
SEBF8075, Guideline for Reusable Parts

Item	Part Number	Description
1	8T-3103	Buffing Tool Group (not serviced)
2	8T-3104	Polishing Compound (not serviced)
3	8T-2840	Bushing Compound
4	8T-3171	Tool Bit (not serviced)
5	8T-3170	Set Screw
Not shown	8T-2841	Pin-Mandrel (Bushing Out)
Not shown	8T-2842	Pin-Mandrel (Bushing In)

## 139-9039 Snap Ring Pliers

Model: 3400 Engines  
Warranty: Six Months

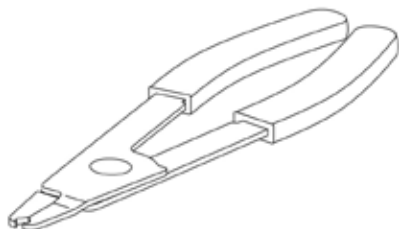

- Used to remove specially designed piston pin retaining rings without holes such as 7E-5665 and 7E-1177
- Holds ring in tight clearance against piston pin
- Overall length: 213 mm (8.4 in)

Part Number	Description
139-9039	Snap Ring Pliers

## 4C-8725 Pin Bushing Adapter

### 4C-8726 Spacer, 4C-8727 Push Adapter

Model: 3500 Family Engines with discontinued 7C-8608 (10°) Connecting Rod Assemblies  
Warranty: Six Months



- Allow 5P-8639 Press Group to be used to remove and install piston pin bearings in 3500 Family Engines with discontinued 7C-8608 Connecting Rod Assemblies (10° taper on piston pin end)
- Fits rods with 10° taper

Part Number	Description
4C-8725	Pin Bushing Adapter
4C-8726	Spacer
4C-8727	Push Adapter

**4C-9749 Push Adapter**

**4C-9750 Bushing Adapter, 4C-9751 Spacer**

Model: All 1.1 Liter Engines

Warranty: Six Months

- Used to remove and install connecting rod bearings
- Provides economical means to rebuild connecting rods

Part Number	Description
4C-9749	Push Adapter
4C-9750	Bushing Adapter
4C-9751	Spacer



**313-5978 Pin Bushing Adapter, 313-5979 Spacer**

**Essential Tool**

Model: C27 and C32 Engines

Warranty: Six Months

- Used together to remove and install connecting rod bearings
- Used with a suitable press
- Provides an efficient way to rebuild connecting rods, without damaging components
- Durable, black-oxide coating

Part Number	Description
313-5979	Spacer
313-5978	Pin Bushing Adapter

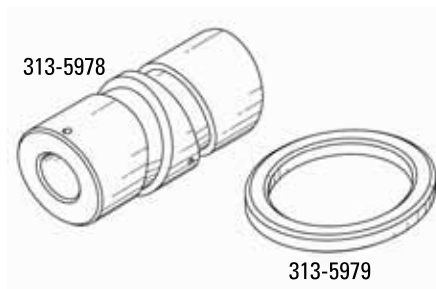

**FT1571 Piston Storage Cabinet and Connecting Rod Assembly**

Model: Cat® Engines

Warranty: None

- After reconditioning, piston and connecting rod assemblies must be covered with oil and placed in a clean storage area; cabinet keeps these components clean and provides good access
- Cabinet doors made of Plexiglass front and back permitting piston and rod assemblies to be put into cabinet on one side and removed from other side
- Doors are fastened to rollers and slide past each other
- Clear Plexiglass keeps dirt out but permits service personnel to see how many assemblies are available
- Rear of cabinet can be made from sheet metal if it is not necessary to enter cabinet from both sides
- Size (H x W x D): 2134 x 2159 x 1219 mm (84 x 85 x 48 in)



## Fabricated Tools for Use in Reconditioning Piston and Connecting Rod Assemblies

Model: Cat® Engines

Warranty: None



- Used when reconditioning large numbers (batch processing) of pistons and/or connecting rod assemblies
- Make it possible to work on several pistons and/or connecting rod assemblies at same time decreasing amount of time needed for reconditioning

Part Number	Description
FT1694	Piston and Rod Disassembly Fixture

## FT1716 Bolt Installation Tool



Part Number	Description
FT1716	Bolt Installation Tool

## FT1765 Fixture, Holding, Connecting Rod

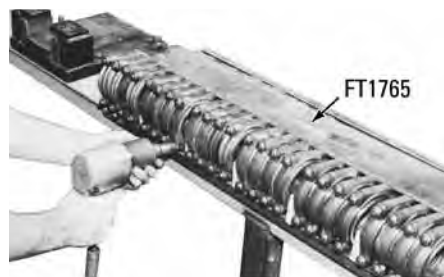

Part Number	Description
FT1765	Connecting Rod Holding Fixture

## Ring Heater

Model: All Models

Warranty: Six Months

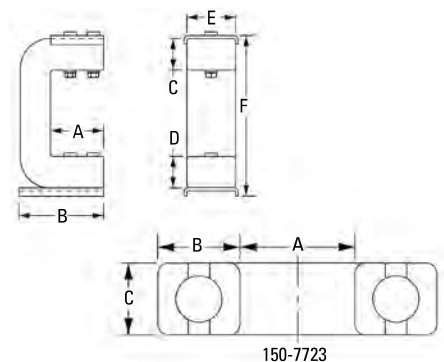

- 150-7723 Ring Heater replaces discontinued 1U-5454 Heater Ring

150-7723 Ring Heater	
Item	Size
A	60 mm
B	95 mm
C	35 mm
D	35 mm
E	55 mm
F	180 mm

Part Number	Description
150-7723	Ring Heater



**360-3040 and 364-1170 Induction Heaters**

**Essential Tool**

Model: All models

Warranty: Manufacturer's

European Union compliant, CE marked

- Replaces canceled 6V-6996 and 6V-7118 Bearing Heaters
- Used to heat metal bearings, gears, rings, and bushings where a press fit is required
- Part heated by low voltage and high current induction to ensure equal temperature over the entire part (inner and outer ring)
- Suitable for use with sealed bearings, shielded bearings, pre-greased bearings, and bearings with polyamide cages
- Pivoting yoke design reduces unnecessary handling, reduces risk of contamination
- Suitable for continuous use — without any additional cooling system
- Includes a temperature detector (sensor) for monitoring part temperature during normal heating only
- If higher temperatures are required, use 164-3310 Infrared Thermometer
- Includes five different size induction yokes for maximum versatility
- Intelligent, programmable electronic unit:
  - includes IR remote control
  - set time and temperature to heat parts uniformly
  - program count down before heater start
  - probe and microprocessor constantly monitor heating process
  - power can be set manually from 0 to 100%



**Repair Information**

TM Induction Heating US Sales

Office: 720-266-4403

Mobile: 720-838-5980

Fax: 303-646-4880

E-mail: rick@tminduction-us.com

Website: www.tminduction-us.com

Part Number	Description
360-3040	Induction Heater
364-1170	Induction Heater

# Pistons, Rings and Connecting Rods

## 360-3040 and 364-1170 Induction Heaters (Continued)

Engine Tools

Voltage	
360-3040	110 V
364-1170	220V
Frequency	50 or 60 Hz
Power	3.6 kVA
Residual magnetism	less than 2 A/cm
Temperature mode	maximum 240° C (464° F)
Temperature control accuracy	±2° C (3.6° F)
Timer accuracy	.01 seconds
Weight	36 kg (68.3 lb)
Dimensions	420 x 260 x 360 mm (16.8 x 10.2 x 14.7 in)
U-core width (D)	180 mm (11.0 in)
U-core height (E)	160 mm (6.3 in)

### 360-3040 and 364-1170 Induction Heaters - Yoke Dimensions

Induction Yoke Size	Part-Minimum Bore (A)	Part-Maximum Outside Diameter (B)	Part-Maximum Outside Diameter (B) With Optional Extension Yoke <sup>1</sup>	Part-Maximum Width (C)	Part-Maximum Weight
10 x 10 x 280 mm (0.39 x 0.39 x 11.02 in)	15 mm (0.59 in)	330 mm (12.99 in)	570 mm (22.44 in)	180 mm (11.02 in)	5 kg (11 lb)
14 x 14 x 280 mm (0.55 x 0.55 x 11.02 in)	20 mm (0.78 in)	345 mm (13.58 in)	585 mm (23.03 in)	180 mm (11.02 in)	15 kg (33 lb)
25 x 25 x 280 mm (0.98 x 0.98 x 11.02 in)	35 mm (1.37 in)	355 mm (13.97 in)	595 mm (23.42 in)	180 mm (11.02 in)	25 kg (55 lb)
40 x 40 x 280 mm (1.58 x 1.58 x 11.02 in)	60 mm (2.36 in)	360 mm (14.17 in)	600 mm (23.62 in)	180 mm (11.02 in)	40 kg (88 lb)
50 x 50 x 280 mm (1.96 x 1.96 x 11.02 in)	70 mm (2.75 in)	410 mm (16.14 in)	600 mm (23.62 in)	180 mm (11.02 in)	35-70 kg (77-154 lb)

<sup>1</sup>Optional Extension Yoke 50 x 50 x 120 mm (1.96 x 1.96 x 4.72 in)

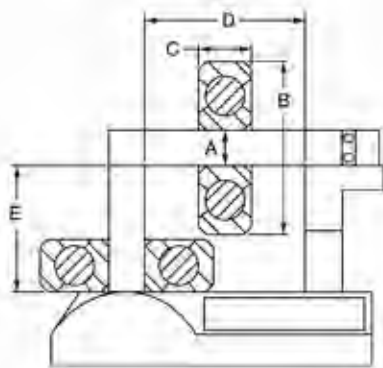

### 274-5875 Connecting Rod Guide Assembly

#### Essential Tool

Model: C175 Engine  
Warranty: Six Months

- Used in pairs to position C175 Engine connecting rods during removal and installation
- Covers connecting rod end to prevent crankshaft and bearing journal damage
- Helps guide connecting rod over crankshaft rod journal during disassembly and assembly
- Guides are made from lightweight plastic
- Spring pins locate guide on connecting rod
- Guide is attached to connecting rod using 276-0100 Bolt installed through center opening
- Two guides used on each connecting rod — order in pairs

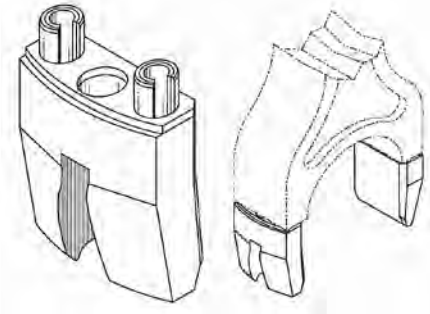

#### Reference

REN7466, C175-16 Generator Set Engine, Disassembly and Assembly, Pistons, Liners, and Connecting Rods, Remove and Install

Part Number	Description
274-5875	Connecting Rod Guide Assembly

### 339-6503 Bolt

#### Essential Tool

Model: C175 Cat® Engines  
Warranty: Six Months

- Replaces canceled 276-0010 Bolt
- Used to attach 274-5875 Connecting Rod Guide Assembly to connecting rod to protect engine components during engine disassembly and assembly
- M10 socket head bolt has M13 x 1.5 threads and is 82 mm (3.2 in) long
- Two required for use with connecting rod guide assembly

#### References

KENR6052, C175-16 and C175-20 Engines for Caterpillar Built Machines, Disassembly and Assembly  
REN7466, C175-16 Generator Set Engine, Disassembly and Assembly

Part Number	Description
339-6503	Bolt

### 370-9186 Spacer, 322-6227 Center Plug

#### Essential Tool

Model Usage: C15 Engine  
Warranty: Six Months

- Used to remove and install connecting rod wrist pin bearing
- Used with base plate of 5P-8639 Press Group
- Material: steel

#### Reference

SEBF8242, Engine Service Manual, Procedure for Removing and Installing Connecting Rod Bearing

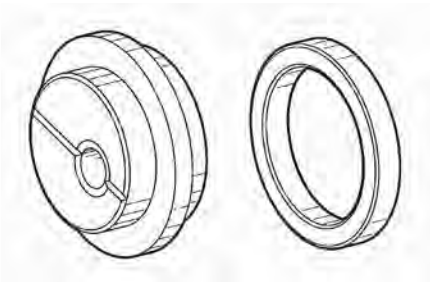

Part Number	Description	Overall Size	Weight
322-6227	Center Plug	100 mm (3.9 in) dia x 15.6 mm (.61 in) thick	0.381 kg (0.83 lb)
370-9186	Spacer	124 mm (4.9 in) dia x 50.0 mm (1.96 in) thick	3.1 kg (6.8 lb)

## 364-2837 Installer Assembly (Ring Compressor)

### Essential Tool

Model Usage: G3512E and G3520E Engines

Warranty: Six Months

Engine Tools

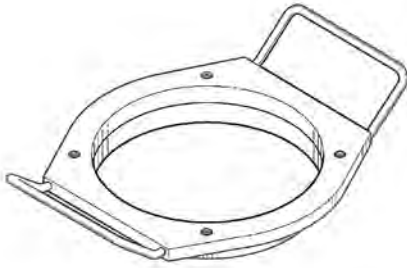

- Used to install piston and connecting rod assembly into engines with 350-0074 Cuffed Liners
- Fits inside of liner allowing rings to pass through cuffed section
- One-piece design
- Heat-treating and electrolysis nickel plating make tool very durable
- Teflon coating reduces friction of rings passing through tool during assembly

Part Number	Description	Overall Size	Weight
364-2837	Installer Assembly (Ring Compressor)	30.4 x 21.1 x 3.18 cm (12 x 8.3 x 1.25 in)	1.5 kg (3.3 lb)

## Camshaft and Timing Gear Tools

### FT0751 Camshaft Alignment Sleeve

Models: D379, G379, D398, G398, D399, G399

Warranty: None

- Used when installing camshaft
- Fits over tapered end of camshaft and guides it into position, minimizing possibility of bearing damage

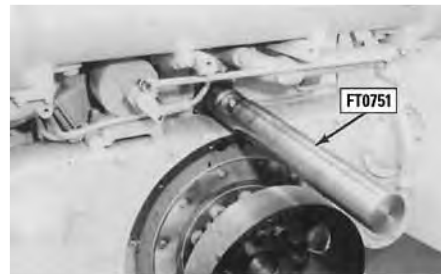

Engine Tools

### 131-1525 Camshaft Alignment Pilot Assembly

Model: C-10 and C-12 Engines

Warranty: Six Months

- Used to remove and install camshafts (threads directly onto end of camshaft)
- Made from aluminum to prevent damage to cam bearings
- 2 cross-drilled holes provide means of removing pilot assemblies after camshaft is installed
- 2 required — thread 4 into the other to make installation between engine and firewall easier

#### References

SENR1002, Service Manual Module

SENR1007, Service Manual Module

Length	98 mm (3.9 in)
Outside diameter	74.74 mm (2.943 in)
Stud	M10 x 1.5 thd

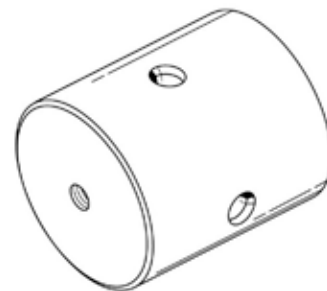

Part Number	Description
131-1525	Camshaft Alignment Pilot Assembly

### Camshaft Installation Tools

Model: 3500

Warranty: Six Months

- Direct replacement for discontinued 6V-4019 Pilot Group; new tooling can be used on all earlier engines
- When installing camshaft into camshaft bearings in cylinder block, it is necessary to provide pilot/guide for camshaft to prevent damage to bearings; because of changes in camshafts of 3500 engines, there are new installation tools that pilot camshaft from both ends until camshaft is in place
- Designed so camshaft can be installed from either end of engine

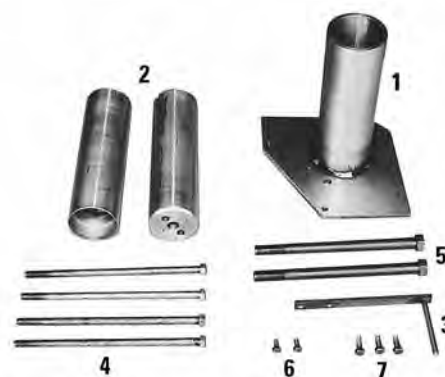

(Continued)

# Camshaft and Timing Gear Tools

## Camshaft Installation Tools (Continued)

Model: 3500

Warranty: Six Months

Engine Tools

Item	Part No.	Description	Size	Qty.
1	8T-3167	Guide As-sembly	--	1
2	8T-3168	Pilot Assembly	--	2
3	8T-3169	Crank As-sembly	--	1

Item	Part No.	Description	Size	Qty.
4	8S-3887	Bolt	1/2 in - 13 x 11 inL	4
5	4J-7945	Bolt	3/4 in - 10 x 1 1/2 inL	2
6	OS-1617	Bolt	5/16 in - 18 x 3/4 inL	2
7	OS-1594	Bolt	3/8 in - 16 x 1 inL	3

### Application Procedure

1. Use three OS-1594 Bolts, finger tight, to install 8T-3167 Guide Assembly on flywheel housing or front cover as shown
2. Install 8T-3168 Pilot Assemblies and 8T-3169 Handle Assembly on camshaft as shown. 2-piece camshafts should be separated for installation.
3. Put engine oil on all bearings and camshaft journals. Install pilot and camshaft through guide assembly until pilot is located in first bearing. Tighten bolts on guide assembly while turning camshaft.
4. On 3508 Engines, complete the installation of the camshaft while rotating camshaft. Remove tooling and complete engine assembly.

On 3512 and 3516 Engines, one end of separated camshaft is rotated and installed as far as camshaft joint. Attach other end of camshaft and complete installation while rotating camshaft. Remove tooling and complete assembly of engine.

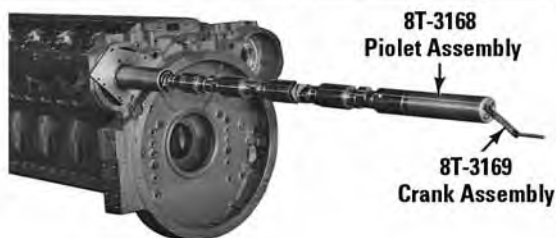
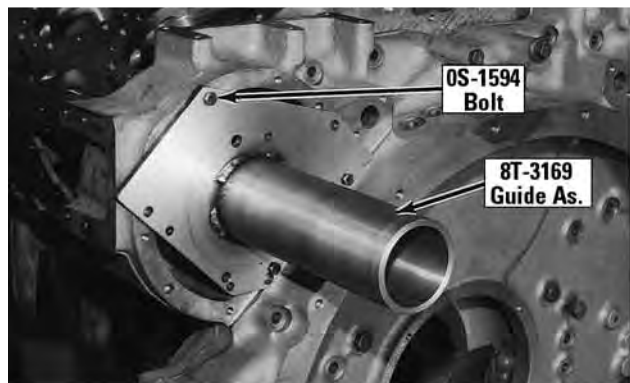

## Camshaft Removal and Installation Tools

Model: C175 Engine  
 Warranty: Six Months

Part Number	Description
255-2820	Camshaft Pilot Assembly
8T-3169	Crank Assembly
282-9962	Camshaft Guide Assembly

- Used to remove and install camshaft from front or rear of engine
- Pilot assembly used with 8T-3169 Turning Handle
- Guide can be mounted to cylinder block or to front or rear engine rollover adapter plates
- Pilot assembly simultaneously engages two cam bearings to ensure proper alignment
- Camshaft pilot and turning handle provide smooth access into cam bearings



### Reference

REN7466, C175-16 Engine Disassembly and Assembly Manual

## 125-0200 Camshaft Pilot

Model: 3500B Engine with Large Diameter Camshaft  
 Warranty: Six Months

- Used to remove and install 106-4584 Camshaft — simply threads onto end of camshafts and functions as a guide during installation or removal
- Used with 8T-3169 Crank Assembly to help rotate camshaft during engine assembly and disassembly (use two 0S-1617 Bolts to attach crank assembly to camshaft)
- Length of pilot is designed to be supported by 2 camshaft journals at the same time (prevents camshaft from dropping as it is installed through each bearing journal)
- Groove in end of pilot provides clearance for dowel pin in camshaft (eliminates removal of dowel)
- Made from aluminum to prevent scratching or other damage to journal surfaces
- Diameter: 91.9 mm (3.62 in)
- Length: 305.0 mm (12.0 in)

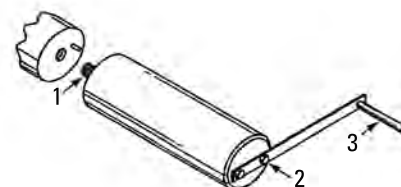

Item	Part Number	Description	Quantity
1	2P-1303	Taperlock Stud (part of 125-0200)	--
2	0S-1617	Bolt	2
3	8T-3169	Crank Assembly	--
--	125-0200	Camshaft Pilot	--

## 125-0201 Camshaft Guide Assembly

Model: 3500B Engines

Warranty: Six Months

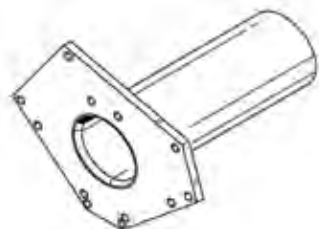

- Used to install camshaft from either end of engine
- Reduces installation time and helps prevent camshaft bearing damage
- Used with front or rear housing in place (does not bolt to bare block face)
- Overall length: 303.0 mm (11.9 in)
- Tube inside diameter: 91.98 mm (3.621 in)

Part Number	Description
125-0201	Camshaft Guide Assembly

## Camshaft Removal and Installation Tools

Model: 3406E Engines

Warranty: Six Months

- Used to remove and install camshaft in chassis
- Prevents damage to camshaft and bearings
- Provides way to lift camshaft without pinching fingers

### References

SEN5580, Service Manual, 3406E Engines

SEN6421, Disassembly and Assembly Manual

Camshaft Removal and Installation Tools Specifications	
9U-7256 Guide Assembly (Item 1)	
Tube (outside diameter x length)	102 x 195 mm (4.0 x 7.7 in)
Plate (W x L x T)	205 x 296 x 9.5 mm (8.0 x 11.6 x 0.38 in)
Plate offset from end of tube	65 mm (2.5 in)
274-7932 Guide Assembly - Front (Item 1)	
Tube (outside diameter x length)	102 x 228 mm (4.0 x 8.9 in)
Plate (W x L x T)	203.2 x 203.2 x 9.5 mm (8.0 x 8.0 x 0.38 in)
Plate offset from end of tube	80 mm (3.15 in)
274-7933 Guide Assembly - Rear (Item 1)	
Tube (outside diameter x length)	102 x 203 mm (4.0 x 8.0 in)
Plate (W x L x T)	249 x 279 x 9.5 mm (9.8 x 11.0 x 0.38 in)
Plate offset from end of tube	65 mm (2.5 in)
9U-7243 Alignment Sleeve (Item 2)	
Material	Steel tube
Tube (diameter x length)	85 x 430 mm (3.3 x 17.0 in)
9U-7225 Camshaft Pilot (Item 3)	
Material	Aluminum
Rod (diameter x length)	84 x 85 mm (3.3 x 3.3 in)
Threaded stud (serviced by 3D-0490 Stud)	1/2 in-13 x 1.0 in
9U-7240 Camshaft Lifting Hook (Item 4)	
Handle (diameter x length)	25 x 120 mm (1.0 x 4.8 in)
Hook (diameter x length)	6.4 x 180 mm (0.25 x 7.0 in)
9U-7257 Cradle Assembly (Item 5)	
Rod (diameter x length)	40 x 140 mm (1.5 x 5.4 in)
Plate (W x L x T)	91 x 130 x 7.9 mm (3.5 x 5.0 x 0.31 in)

(Continued)



## Camshaft Removal and Installation Tools (Continued)

Model: 3406E Engines

Warranty: Six Months



Item	Part Number	Description
1	9U-7256	Guide Assembly
1	274-7932	Guide Assembly - Front
1	274-7933	Guide Assembly - Rear
2	9U-7243	Alignment Sleeve
3	9U-7225	Camshaft Pilot
4	9U-7240	Camshaft Lifting Hook
5	9U-7257	Cradle Assembly

## 177-8003 Cam Tool Group

Model: 3406E, 3456, C-15, C-16, C27/C32

Warranty: Six Months

- Used to remove camshaft through front or rear of cylinder head
- Used with three 6L-4697 Bolts to connect adapter to camshaft (not included)
- Used on many machines, cab over trucks, or when cylinder head is off for repair
- Saves time by allowing cam removal without removing other components
- Pilot sleeve simultaneously engages 2 cam bearings to guide cam without damaging bearings — loosely assemble components to prevent tool alignment problems
- To remove camshaft through front of cylinder head, screw only pilot sleeve into opposite end of camshaft
- To remove cam through rear of head: 1) remove cam gear; 2) bolt adapter onto camshaft; 3) screw pilot sleeve onto adapter
- Minimum pilot sleeve clearance between head and other components: 368.0 mm (14.5 in)

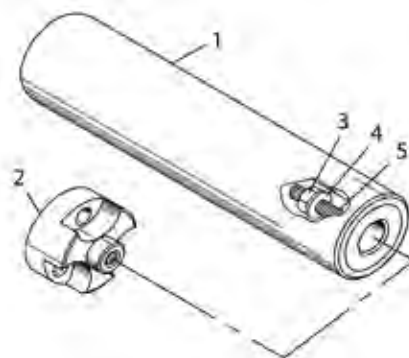

(Continued)

# Camshaft and Timing Gear Tools

## 177-8003 Cam Tool Group (Continued)

Model: 3406E, 3456, C-15, C-16, C27/C32

Warranty: Six Months

Item	Part Number	Description
1	177-8001	Pilot Sleeve
2	249-2936	Adapter (C27/C32 front install)
2	177-8002	Adapter (3406, C-15, C-16, C27/C32 rear install)

Item	Part Number	Description
3	1F-7958	Full Nut (1/2 - 13) (fork mounting hardware)
4	5P-8245	Hard Washer
5	3D-0472	Taperlock Stud
--	177-8003	Cam Tool Group

## 8S-2241 Camshaft Bearing Installation and Removal Group

Model: Cat® Engines

Warranty: Six Months

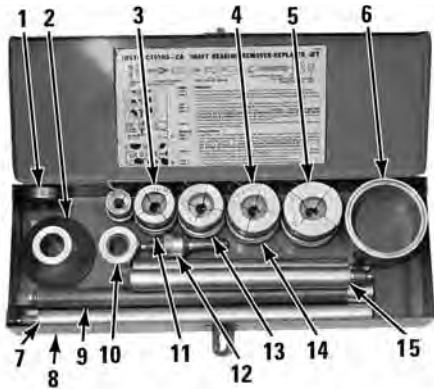

- Used to remove and install camshaft bearings in most Cat® Engines
- Each collet designed to handle bearing diameter range listed in chart; replacement O-ring seals used to retain collets also listed

Item	Description
13	Backup Nut
Collet Assembly Specifications	
Collet	Inner Diameter Size Range Replacement O-Ring Seals
8S-8285	60.33 - 69.85 mm (2.375 - 2.750 in) 4J-0524

Item	Part Number	Description
1.0	8S-8287	Thrust Bearing Assembly
2.0	8S-8288	Cone
3.0	8S-8282	Collet Assembly
4.0	8S-8284	Collet Assembly
5.0	8S-8285	Collet Assembly
6.0	8S-8289	Tube
7.0	8S-8293	Long Extension
8.0	8S-8281	Tool Box

Item	Part Number	Description
9.0	8S-8291	Threaded Shaft
10.0	8S-8290	Nut
11.0	8S-8884	Backup Nut
12.0	8S-8286	Screw Expander
14.0	8S-8882	Backup Nut
15.0	8S-8292	Short Extension
--	8S-2241	Camshaft Bearing Installation and Removal Group

## 5P-1666 Puller Plate

## 5P-1667 Spacer Tube

Model: D379B, D398B, D399, 657E

Warranty: Six Months



- Used with 8S-2241 Group for camshaft bearing removal and installation on 6.25 inch bore V Engines (two 8S-8292 Short Extensions and one 8S-8293 Long Extension required from 8S-2241 Group)

Item	Part Number	Description
1	5P-1666	Puller Plate
2	5P-1667	Spacer Tube
3	8S-8292	Short Extension
4	8S-8293	Long Extension

## 1P-5545 Adapter Group

Model: 1100, 3100, 3208

Warranty: Six Months

Part Number	Description
1P-5545	Adapter Group
0S-0509	Bolt (3/8 - 16)

- Used with 8S-2241 Tool Group to install camshaft bearings on 1100 and 3100 Series and 3208 Engines



## 6V-4869 Adapter

### 6V-6174 Plug

Model: 3400

Warranty: Six Months

Part Number	Description
6V-4869	Adapter
6V-6174	Plug

- Used with 8S-2241 Tool Group to remove and install camshaft bearings in 3400 Series Engines
- 6V-4869 Adapter used for collet assembly
- 6V-6174 Plug used for cone



## Camshaft Bearing Remove/Install Tools

Model: 3500B Engines

Warranty: Six Months

Part Number	Description
125-2739	Cam Bearing Pilot
125-2740	Backup Plate
125-2741	Cam Bearing Sleeve

- Used to remove and install 2 sizes of camshaft bearings — makes overhaul much simpler and reduces chance of bearing damage during installation
- Used with 6V-4077 Camshaft Bearing Tool Group and 8S-2241 Camshaft Bearing Installation and Removal Group
- Designed to trap camshaft bearing between camshaft bearing pilot and backup plate — can be pushed (removed) or pulled (installed) using 6V-4077 and 8S-2241 Tool Groups
- Install thin-walled bearings by placing 125-2741 Camshaft Bearing Sleeve over the camshaft bearing pilot
- Parts are plated and hardened for durability and long life

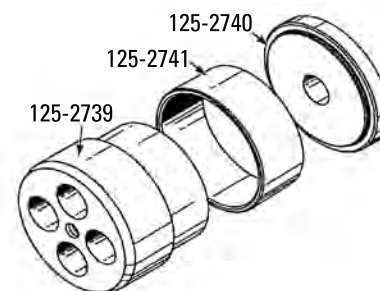

# Camshaft and Timing Gear Tools

## Installation of Camshaft Bearing

Typical Installation of camshaft bearing

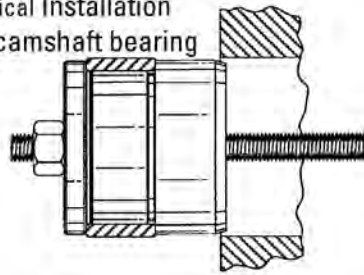

Larger diameter of pilot	97.9 mm (3.85 in)
Small diameter of pilot	85.9 mm (3.38 in)
Outside diameter of sleeve	92.1 mm (3.63 in)

Engine Tools

## 6V-4077 Camshaft Bearing Tool Group

Model: D11N, 3512, 3516, 777B, 785, 789, 994

Warranty: Six Months



- Used with components of 8S-2241 Tool Group for manual removal and installation of camshaft bearings in 3500 Series Engines
- Otherwise 316-1493 Hydraulic Puller can be used

Item	Part Number	Description
--	6V-4077	Camshaft Bearing Tool Group
1	6V-4011	Spacer
2	6V-4015	Pulling Bar
3	6V-4013	Screw
4	2J-3506	Nut
5	5P-8248	Washer
6	0S-1621	Bolt
7	6V-3177	Pilot Group
8	6V-4012	Plate
9	6V-4010	Pulling Plate
10 <sup>1</sup>	6V-4005	Spacer
<b>Not Shown</b>		
--	6V-2054	Shield Driver

<sup>1</sup>Qty. 2

## Camshaft Bearing Remove/Install Tools

Model: C-10 and C-12 Engines

Warranty: Six Months

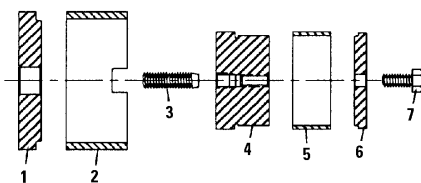

- Used to remove and install camshaft bearings
- Used with 8S-2241 Camshaft Installation and Removal Group, 0S-1629 Bolt, and 8M-8778 Taperlock Stud
- Tools can be used to remove or install camshaft bearings (for installation, assemble parts as shown in illustration)
- Large diameter of bearing pilot guides bearing into bearing bore on engine for easier installation
- Reaction sleeve is designed with clearance for bolts on engine front housing

### References

SENR1002, Special Instruction C-10 Disassembly and Assembly  
SENR1007, Special Instruction C-12 Disassembly and Assembly

(Continued)

## Camshaft Bearing Remove/Install Tools (Continued)

Model: C-10 and C-12 Engines

Warranty: Six Months

129-6673 Bearing Pilot	
Overall outside diameter	80.92 mm (3.186 in)
Outside diameter of bearing pilot	74.850 mm (2.9469 in)
Item	Description
5	Camshaft Bearing

Item	Part Number	Description
<b>Camshaft Bearing Tooling</b>		
1	129-6672	Puller Plate
2	129-6671	Reaction Sleeve
3	8M-8778	Taperlock Stud
4	129-6673	Bearing Pilot
6	129-6674	Backup Plate
7	0S-1629	Bolt
<b>Not Shown</b>		
--	8S-2241	Camshaft Bearing Installation and Removal Group

## Camshaft Plates, Pilots, and Sleeves

Model: C-11 and C-13 Engines

Warranty: Six Months

Part Number	Description
<b>Service/Repair Parts</b>	
201-4208	Backup Plate
201-4209	Bearing Pilot
201-4211	Pilot Assembly
201-4212	Pilot Assembly
201-4213	Puller Plate
201-4214	Receiving Sleeve

- Used to remove and install camshaft bearings
- Used with 8S-2241 Camshaft Installation and Removal Group
- Large diameter of bearing pilot guides bearing into bearing bore on engine block for easier installation
- Receiving sleeve designed with clearance for front housing engine bolts

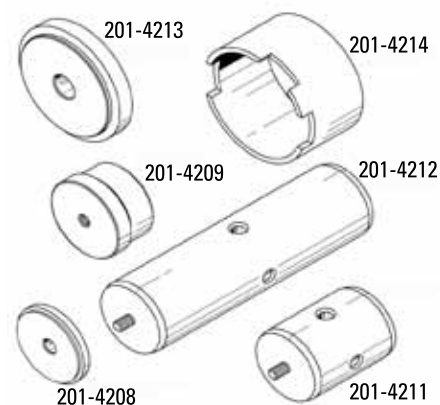

## Camshaft Bearing Removal and Installation Tools

Model: 3406E Engines

Warranty: Six Months

- Used to remove and install camshaft bearing with head removed
- Used with 8M-8778 Stud, 6V-4013 Threaded Screw, 8S-8292 Short Extension, (2 required), 8S-8293 Long Extension, (2 required), 2J-3506 Nut, 5P-8248 Washer, 316-1493 Hydraulic Puller Assembly and hydraulic pump
- Hydraulic force easily removes bearings and prevents damage during installation



### References

SEN5580, Service Manual, 3406E Engine

SEN6421, Disassembly and Assembly Manual

(Continued)

## Camshaft Bearing Removal and Installation Tools (Continued)

Model: 3406E Engines

Warranty: Six Months

Item	Part Number	Description	Overall Dimensions (Diameter x Thickness)
1	9U-7210	Puller Plate	95.0 x 19.0 mm (3.75 x 0.75 in)
2	9U-7223	Alignment Bushing	85.0 x 32.0 mm (3.30 x 1.25 in)
3	9U-7222	Cam Bearing Pilot	90.0 x 70.0 mm (3.50 x 2.75 in)
4	9U-7213	Backup Plate	108.0 x 57.0 mm (4.25 x 2.25 in)
5	9U-7214	Spacer Plate	90.0 x 4.0 mm (3.50 x 0.16 in)

## 132-3904 Camshaft Retainer

Model: 3406E Engines

Warranty: Six Months

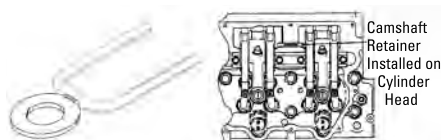

- Used to hold camshaft in cylinder head during removal and installation
- Install retainer across camshaft bearing between 2 camshaft lobes
- Failure to use retainer can result in damaged camshafts (retainer is extremely cost-effective when compared to price of new camshaft)

Part Number	Description
132-3904	Camshaft Retainer

## 1U-7638 Magnetic Lifter Holder

### Essential Tool

Model: C7, C9, C11, and C13 Engines

Warranty: Six Months

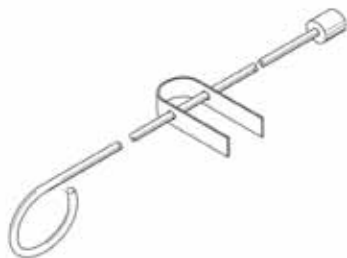

- Used to hold lifters in up position when removing and installing camshaft
- Eliminates interference between lifters and camshaft for faster removal and installation
- 1 tool required for each lifter bore on engine
- Easily adjustable

Part Number	Description
1U-7638	Magnetic Lifter Holder

### References

REN9707, C7/C9 Disassembly and Assembly Manual

REN9705, C11/C13 Disassembly and Assembly Manual

### Gear Installation Tools

Model: 933, 951, 955, 977

Warranty: Six Months

Item	Part Number	Description
2	4M-3251	Adapter
1	1B-4210	Nut

- Necessary only when installing accessory drive shaft with engine installed in 933 Traxcavators and in 951, 955, and 977 Traxcavators with 114.3 mm (4.5 in) bore engines equipped with mechanical governors

Item	Description
3	Spacer



### 173-2021 Puller Group

Model: 3300 Engine

Warranty: Six Months

Part Number	Description
173-2021	Puller Group

- Used to quickly and easily remove or install idler gear stub shaft with a common slide hammer
- Used with 1U-7600 Slide Hammer or similar tool with 1/2 - 20 threads
- Helps eliminate damage to bore of cylinder block and stub shaft
- Used by slipping cup over the stub shaft; insert puller pin through side of cup and oil feed hole in the stub shaft
- Inside bore diameter: 35 mm (1.38 in)
- Service Part: 173-2023 Pin

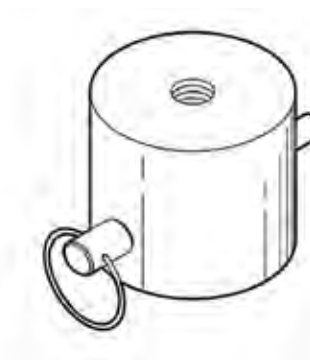

### 393-2573 Idle Gear Removal and Installation Tool

Model Usage: C3.8

Warranty: Manufacturer's

- Used to easily remove and install idler gear

Specifications	
Dimensions	198.1 x 47.81 mm (7.72 x 1.88 in)
Weight	.957 kg (2.1 lbs)

Part Number	Description
393-2573	Idle Gear Removal and Installation Tool



## 8F-3672 Gear Removal Plate

Model: Cat® Engines

Warranty: Six Months



- Removal of camshaft or accessory drive gear with hydraulic puller (2) is simple operation combining use of plate (1) and push-puller (3)

Item	Part Number	Description
1	8F-3672	Plate
2	6V-3160	Cylinder Group
3	8B-7548	Puller Assembly - Bearing

## 167-3834 Puller Group

Model: 3176, 3176B, 3196, C-10, and C-12

Warranty: Six Months

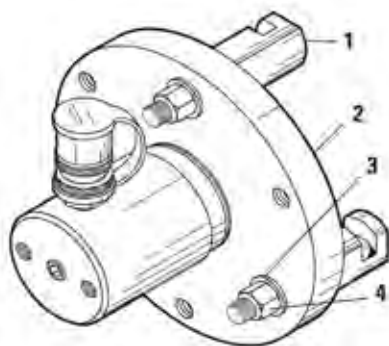

- Used to remove press fit camshaft gear without pulling camshaft or disturbing overhead components
- Used with dealer supplied 10,000 psi 1U-5230 Single Acting Hand Pump, 3S-6224 Electric Hydraulic Pump, or equivalent
- Used with induction gear heater to install cam gear (not included)
- Saves time on front cover repairs
- For engines built through May 1998
- Only works on cam gears with lightening holes; will not fit solid hub gears

### Reference

NEHS0760, Tool Operating Manual

Hydraulic ram	single action
Ram stroke	51 mm (2.0 in)
Ram capacity	25 ton

Item	Part Number	Description
1	167-1999	Puller Leg
2	167-1998	Puller Plate
3	5P-8247	Hard Washer
4	6B-6683	Nut
--	167-3834	Puller Group
<b>Required parts, not included</b>		
1	5P-8245	Hard Washer
3	5P-2566	Hex Head Bolt
--	138-7575	Bracket - Link



## 9U-6896 Guide Bolt

Model: 3406E Engines

Warranty: Six Months

Part Number	Description
9U-6896	Guide Bolt

- Used to easily align camshaft gear during installation by supporting weight of camshaft gear
- Used with 1P-7405 Eyebolt
- Length: 127 mm (5.0 in)
- Thread: 5/8 in - 11

### References

SENR5580 Service Manual

SENR6421 Service Manual Module, Disassembly and Assembly 3406E Engines

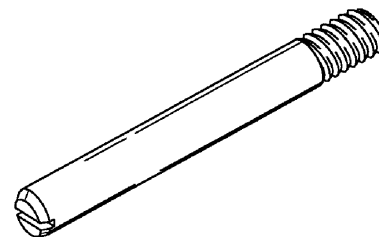

## 8S-2264 Puller Group

### 8S-8375 Sleeve

Model: D330C, D333C, 3304 and 3306 Engines

Warranty: Six Months

Item	Part Number	Description
--	8S-2264	Puller Group
<b>8S-2264 Puller Group</b>		
1.0 <sup>1</sup>	8S-8375	Sleeve
2.0	8S-5133	Plug
3.0	8S-6470	Screw
4.0	8S-5132	Puller Plate

Used for various pulling operations such as:

- Removing accessory drive gears on D330C, D333C, 3304 and 3306 Engines
- Removing crankshaft front pulley on 1100 and 3100 Series Engines
- Water pump disassembly and assembly on D342, D353 and 3406 Engines
- Used with an 8S-8375 Sleeve to remove the accessory drive gear on 12.07 cm (4.75 in) bore 2-valve engines
- Also used in other general purpose applications
- Available separately: 6V-7837 Screw, length 71.37 mm (2.81 in), 3/4 inch-16 thread

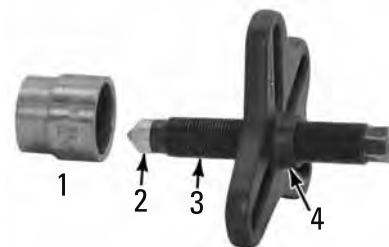

Item	Description
4	Puller Plate

<sup>1</sup>Not part of 8S-2264 Group

## 4C-5613 Puller Group

Model: 3406

Warranty: Six Months

- Used to remove air compressor drive gear



(Continued)

# Camshaft and Timing Gear Tools

## 4C-5613 Puller Group (Continued)

Model: 3406

Warranty: Six Months

- Has wide puller jaws that distribute load across more surface area on gear and prevent damage to splined teeth; conventional puller jaws will not properly grab under gear hub due to clearance problems, so they are used to grab in spline tooth area where they may damage gear teeth
- Can be used for general purpose pulling operations
- 3-leg, 10-ton puller with wide, flat puller jaws

Item	Part Number	Description
--	4C-5613	Puller Group
1	4C-5628	Crossarm Body
2	4C-5626	Forcing Screw
3	4C-5625	Puller Jaw
4	4C-5624	Spring Clip
5	4C-5627	Tip

## 132-5451 Air Compressor Gear Holder

Model: 3406E, C-10, and C-12 Engines

Warranty: Six Months

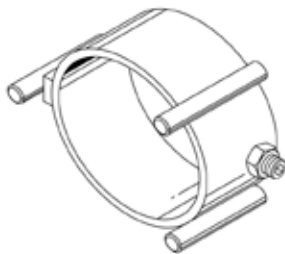

- Used to keep air compressor shaft from turning while removing or tightening drive gear retaining nut
- Holder makes removing and installing nut much simpler and faster — also reduces possibility of damage during overhaul procedure
- Use shop vise to hold air compressor assembly
- Service Part: 6B-6683 Nut

Part Number	Description
132-5451	Air Compressor Gear Holder

Inside diameter	127 mm (5.0 in)
Height including pins	88.9 mm (3.50 in)
Pin diameter	12.7 mm (0.50 in)
Retaining nut final torque	462 ± 54 N·m (340 ± 40 ft-lb)

## 4C-9991 Idler Shaft Retrofit Tool Group

Model: 3500

Warranty: Six Months



- Used to retrofit idler gear shaft on 3500 Vee engines
- Easily and accurately aligns drill and tap for drilling and tapping bolt holes from 1/2 - 13 to 5/8 - 11 thread
- Eliminates replacing cylinder block
- Used with 1P-3048 Wrench Assembly and 1U-9218 Drill, 12.7 mm ( 1/2 in)

### Reference

SEBF8166, Guideline for Reusable Parts

Item	Part Number	Description	Size
--	4C-9991	Idler Shaft Retrofit Tool Group	--
1	9U-5033	Core Drill	17/32 in, 4-fluted
2	9U-5034	Bottoming Tap	-5/8 in - 11 thd
--	1A-5822	Bolt (not part of 4C-9991 Tool Group)	1/2 in to 13 x 2 3/4 in

(Continued)

**4C-9991 Idler Shaft Retrofit Tool Group (Continued)**

Model: 3500

Warranty: Six Months

Item	Part Number	Description	Size
4	9X-8883	Bolt	5/8 in to 11 x 2 3/4 in
5	6V-4857	Lockscrew (2)	--
6	4C-9993	Guide Plate	--
7	4C-9994	Drill Bushing	12.7 mm (0.50 in)
8	4C-9995	Drill Bushing	0.531 in
9	4C-9996	Drill Bushing	0.625 in
10	4C-9997	Drill Bushing	0.635 in (pilot for 0.625 in tap)
<b>Not Shown</b>			
--	4C-9992	Idler Shaft Retrofit Pilot	--

**9U-7255 Adjustable Idler Assembly**

Model: 3406E Engines

Warranty: Six Months

Part Number	Description
9U-7255	Adjustable Idler Assembly

- Used to set backlash between camshaft gear and adjustable idler gear
- Used with 9U-7324 Indicator Bracket, 7H-1942 Dial Indicator, 3S-3268 Contact Point, and 7H-1940 Universal Attachment (assures correct setting of backlash after tightening mounting bolts to adjustable idler gear)
- Holds adjustable idler gear in correct position while tightening mounting bolts
- Distance between centers: 204.03 mm (8.033 in)



**References**

SENR5580, Service Manual  
SENR6421, Service Manual Module, Disassembly and Assembly 3406E Engine

**9U-6148 Idler Shaft Removal Group**

Model: 3064 and 3066 Engines

Warranty: Six Months

Item	Part Number	Description
1	9U-6147	Removal Stud
2	8T-4244	Nut (M12 x 1.75)
3	9U-6146	Sleeve Assembly
--	9U-6148	Idler Shaft Removal Group

- Used to remove idler gear shaft
- Reference**  
SENR5553, Service Manual, 3066 Diesel Engines

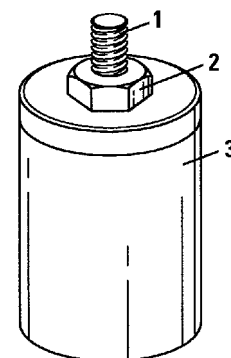

(Continued)

# Camshaft and Timing Gear Tools

## 9U-6148 Idler Shaft Removal Group (Continued)

Model: 3064 and 3066 Engines

Warranty: Six Months

Item	Part Number	Description
<b>Not Shown</b>		
--	6V-8231	Nut (M10 x 1.25)

Engine Tools

## FT2781 Alignment Tool

Model: G3600 Engines

Warranty: None

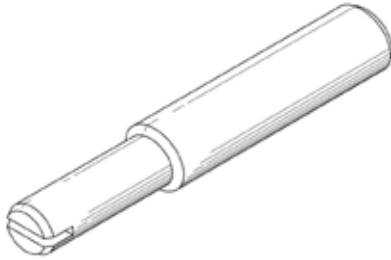

- Used to accurately align ADEM III timing wheel with magnetic pickup
- Procedure for use: Insert tool through magnetic pickup hole and lock onto indicated timing wheel tooth; tighten slotted wheel to correct torque
- Material: SAE 1018 steel

## 9U-7324 Indicator Bracket

Model: 3406E Engines

Warranty: Six Months

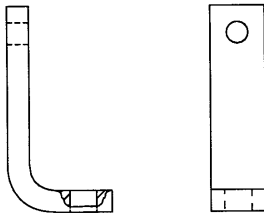

- L-shaped bracket used to fasten dial indicator to front housing (allows backlash between camshaft gear and idler gear to be measured)
- Used with 7H-1942 Dial Indicator, 3S-3268 Contact Point, and 7H-1940 Universal Attachment

Part Number	Description
9U-7324	Indicator Bracket

### References

SENR5580, Service Manual

SENR6421, Service Manual Module, Disassembly and Assembly 3406E Engine

Height	66 mm (2.6 in)
Threaded hole in long leg	1/4 in - 20
Clearance hole in short leg	8.20 mm (0.312 in)

**398-9615 Air Gap Measuring Gauge**

Model Usage: C3.8

Warranty: Manufacturer's

European Union Compliant, CE marked

- Used to measure the crankshaft position sensor
- Provides a quick and efficient method for checking crankshaft position sensor
- Use with 9S-0215 Dial indicator

Specifications	
Part Number	Dimensions
398-9615	104 x 65.6 mm (4.09 x 2.58 in)



### FT0201 Clutch Adjustment Tool

Model: Cat® Engines  
Warranty: None



- Used to adjust clutch on 53.98 mm (2 1/8 in) bore, 53.98 mm (2 1/8 in) stroke starting engines

### 277-7088 Spanner Wrench

#### Essential Tool

Model: G3516B and G3520B Engines  
Warranty: Six Months

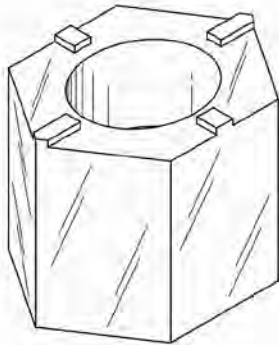

- Used to disassemble and assemble air starter gear box

#### Reference

REN2269, G3516B and G3520B Disassembly and Assembly Manual

Part Number	Description
277-7088	Spanner Wrench

### FT0625 Starting Motor Adjusting Tool

Model: Prestolite Starting Motors  
Warranty: None

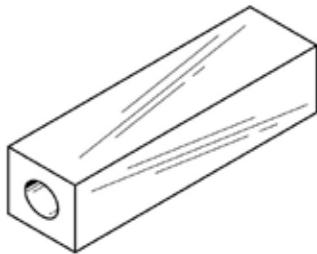

- Used with 8H-8568 Socket, 8H-8505 Wrench, and hollow head wrench to check solenoid shifting adjustment on engines equipped with Prestolite starting motors
- Material: mild steel

**FT3089 Offset Socket****Essential Tool**

Model: 3500 Engines

Warranty: None

- Used to remove top bolt of starting motor on 3500 Engines (5/8 inch socket with offset provides access)
- Used with 1/2 inch square drive wrench
- Made from 8S-1595 Bolt Socket
- Not for use with impact wrenches

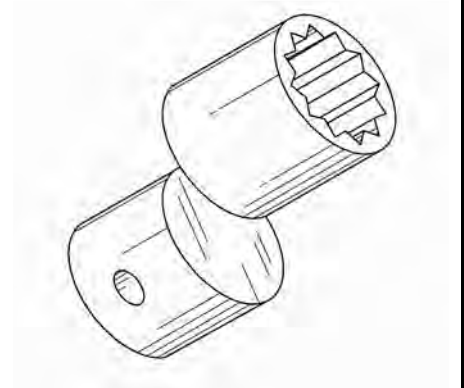

## Engine Lifting and Positioning

### 6V-0097 Engine Rebuild Stand

Model: All engine models from 3204 through D348 and 3412

Warranty: Six Months



- Designed to provide most efficient means for engine reconditioning
- Design permits dynamometer testing of engine on stand
- Normally used with 9S-9081 Sling Assembly and 9S-9060 Dual Hook Hoist to rotate engine during disassembly and assembly
- Superior to former 9S-8500 Stand because of its rigid, 1-piece construction and polyurethane rather than steel wheels
- Portable with use of discontinued 1P-0090 Dolly and channel construction allows handling with lift truck with 2 sides

#### Reference

SMHS7861, Special Instruction

#### NOTE:

To mount D348 or 3412 Engine on earlier 6V-0097 Stands, it is necessary to modify front supports to provide clearance for oil coolers.

Also, to mount 3208 Engines, right rear support must be modified to provide clearance for starting motor. If these modifications are required, request the following drawings from Division Service Manager:

FT1513 — Modification for D348 or 3412 Engines

FT1530 — Modification for 3208 Engines

Length	1854 mm (73 in)
Width	1016 mm (40 in)
Height	610 mm (24 in)
Weight	272 kg (600 lb)

Part Number	Description	Quantity
6V-0097	Engine Rebuild Stand	--
<b>Service/Repair Parts</b>		
6V-2026	Wheel	2
3B-4629	Cotter Pin	4
0S-1587	Bolt	4

Part Number	Description	Quantity
<b>Service/Repair Parts (Continued)</b>		
5P-8245	Hard Washer	12
1A-1135	Bolt	2
5P-8247	Hard Washer	2
1H-1200	Pin	2
4B-4283	Washer	2



## 4C-9832 Large Engine Roll-Over Stand

Model: 3508, 3512 and 3516 Engines

Warranty: Six Months

- Used for disassembly and assembly of 3508, 3512 and 3516 Engines
- Self-contained hydraulic system
- Air-driven hydraulic pump and hoses included
- Protective valve arrangement for positive rotational control
- Portable — heaviest component 86.18 kg (190 lb)
- Does not need permanent mounting
- Does not need electrical power
- Enhances safety of large engine repair
- Minimizes engine handling time — improves work efficiency
- Adaptable for on-site marine engine repair
- Stand-to-engine mounting bolts and brackets for 3500 Engines included
- Engine can be positioned vertically in any of 4 positions by one person without the need of overhead lifting equipment
- Complete 360° rotation of engine
- Each full cylinder stroke provides 90° of engine rotation
- Pivot lock pin provides positive anti-rotational locking every 30°
- Bolt-on feet allow engine stand members to stand alone during installation or storage
- Low enough to be installed on engine resting on its oil pan on floor
- Additional brackets for other engines and off-highway front struts planned for the future
- Two 12-ton jacks included

### Reference

NEHS0566, Tool Operating Manual

Capacity	9072 kg (20,000 lb)
Item	Description
Not Shown, Sold Separately)	NEEG2004, Decal

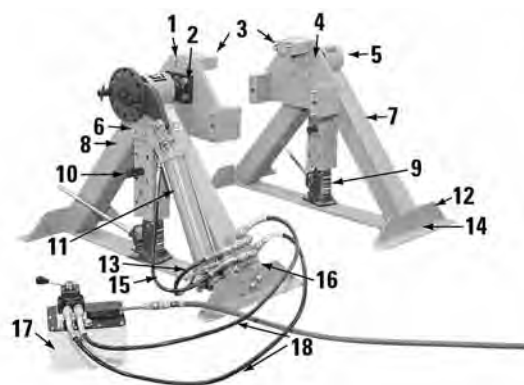

Item	Part Number	Description
9.0	1U-9754	Hydraulic Jack, 12 ton
--	4C-9832	Large Engine Roll-Over Stand
14.0	5P-2228	Bolt, 1/2 in - 13 thd x 25.4 mm (1.0 in)
4.0	6V-8182	Full Nut, 3/4 in - 10 thd
1.0	7X-0341	Bolt, 1/2 in - 13 thd x 177.8 mm (7 in)
2.0	8C-6857	Bolt, 3/4 in - 10 x 69.8 mm (2 3/4 in)
6.0	8T-9313	Bolt, 3/4 in - 10 thd x 177.8 mm (7 in)
7.0	9U-5753	Outboard Frame (not serviced)
8.0	9U-5754	Cylinder End Frame (not serviced)
5.0	9U-5755	Outboard Tube Weldment

Item	Part Number	Description
11.0	9U-5760	Hydraulic Cylinder
3.0	9U-5770	Mounting Bracket, 3500
12.0	9U-5772	Foot (not serviced)
16.0	9U-5773	Counterbalance Valve
17.0	9U-5774	Air/Hydraulic Pump
10.0	9U-5775	Pin Assembly
18.0	9U-5778	Hydraulic Hose, 1828.8 mm (72.0 in)
13.0	9U-5779	Hydraulic Hose, 609.8 mm (24.0 in)
15.0	9U-5780	Hydraulic Hose, 990.6 mm (39.0 in)

(Continued)

# Engine Lifting and Positioning

## 4C-9832 Large Engine Roll-Over Stand (Continued)

Model: 3508, 3512 and 3516 Engines

Warranty: Six Months

Engine Tools

Item	Part Number	Description
<b>Additional Service/Repair Parts (Not Shown, Sold Separately)<sup>1</sup></b>		
--	1J-8136	Roll Pin, 3/8 in x 50.8 mm (2.0 in)
--	1P-2375	Coupler Assembly Quick Connective (Male)
--	1P-2376	Coupler Assembly Quick Connective (Female) (2)
--	2K-3549	Roll Pin, 3/8 in x 101.6 mm (4.0 in)
--	3D-8913	Elbow Pipe, 90 degree - 30 degree NPSM-EXT
--	5S-2201	Hex Socket Head Bolt, 5/8 in - 11 thd x 31.75 mm (1 1/4 in)

Item	Part Number	Description
<b>Additional Service/Repair Parts (Not Shown, Sold Separately) (Continued)<sup>1</sup></b>		
--	6K-8328	Bearing Cup
--	7X-0265	Bolt, 1/4 in - 20 thd x 69.8 mm (2.75 in)
--	8T-0238	Bearing Cone
--	9U-5758	Cylinder End Shaft Weldment
--	9U-5759	Outboard Shaft Weldment
--	9U-5761	Cylinder Mount Pin
--	9U-5762	Spacer
--	9U-5763	Spacer
--	9U-5764	Special Washer
--	9U-5767	Bearing Shield
--	9U-5781	Cotterless HitchPin
--	9U-7828	Index Plate

<sup>1</sup>Also: 457012 Spring Pin

## 171-4660 Engine Stand Adapter Assembly

Model: 3408 and 3412

Warranty: Six Months

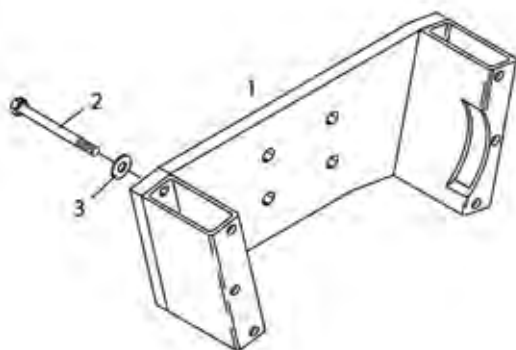

- Used to mount engines to roll-over stand (does not require removal of front gear train)
- Used with 4C-9832 Large Engine Roll-Over Stand
- Front and rear plates are interchangeable
- Camshaft work must be done with front bracket removed
- Flywheel housing and front gear housing must be removed
- Works best as a short block tool

Item	Part Number	Description
1	171-4660	Engine Stand Adapter Assembly
2	4F-0411	Bolt
3	5M-2894	Washer

## C175 Engine Rollover Plates

### Essential Tool

Model: C175 Engine

Warranty: Six Months

- Used with 4C-9832 Engine Rollover Stand to rotate engine for maintenance work
- Front and rear plates are marked and cannot be interchanged
- Center hole in each plate permits attachment of cam guide for cam removal and installation

### Reference

REN7466, C175-16 Engine Disassembly and Assembly Manual

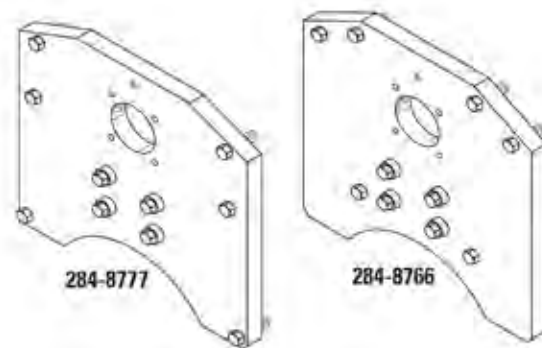

Part Number	Description
284-8766	Front Plant
284-8777	Rear Plate

## 1U-6238 Mount Bracket Group

Model: D379, D398, D399, G379, G398, G399 Engines (6.25 Inch Bore)

Warranty: Six Months

- Used to attach engines to 4C-9832 Large Engine Roll-Over Stand during disassembly and assembly
- Makes engine overhaul simpler and faster while providing a more convenient workspace for mechanic
- Two 1A-7669 Bolts and ten 1D-5499 Bolts included (attaches mounting brackets to engine block)
- Bolts meet or exceed SAE Grade 8

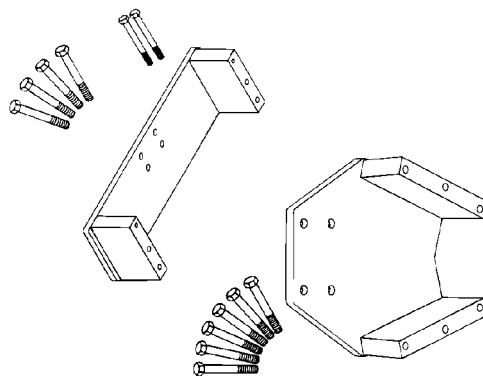

Part Number	Description	Size	Qty.
1U-6238	Mount Bracket Group	--	--
1A-7669	Bolt	1/2 - 13 thd x 178 mm (7.0 in)	2
1D-4599	Bolt	5/8 - 11 thd x 178 mm (7.0 in)	10

## FT1858 Engine Stand Adapter

Model: 3204

Warranty: None

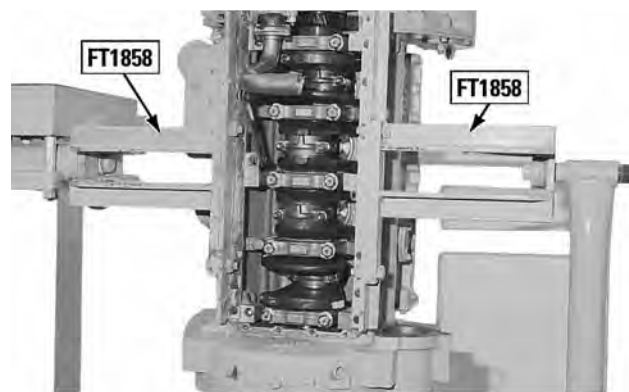

- Used with 1U-7502 Engine Stand for rebuilding 3204 Engines
- Holds engine at convenient working height during disassembly or assembly

## 1U-9352 Engine Stand, 1000 lb

Model: Engines within 1000 lb

Warranty: Six Months



- Use for lift truck, car, and light truck engine service
- 4 adjustable attachment arms make engine mounting fast and easy
- Engine can be rotated full 360° with turn of handle
- Locking pin secures work in any of 8 positions
- Both rear wheels lock tightly to anchor stand; 2 swivel casters in front provide great mobility
- Disassemble by removing only 1 bolt for easy transport

Capacity	454 kg (1000 lb)
Weight	45.4 kg (100 lb)

Part Number	Description
1U-9352	Engine Stand, 1000 lb

## 1U-5750 Diesel Engine Repair Stand, 2722 kg (6000 lb)

Model: Engines within 6000 lb

Warranty: Six Months

- 1U-5750 includes universal engine adapter assembly which permits use of engine mounting adapters
- Integral, 10.89 MT (12 ton) jack raises work to provide swing radius needed to turn work
- Turning even a 2.72 MT (3 ton) diesel 360° is easy — a 96 to 1 ratio worm and gear set does the job easily
- Crank handle can be locked in any position
- 2 front wheels and 2 rear casters permit easy mobility; floor locks anchor 1U-5750 in place
- Required floor space (W x L): 1219.2 x 1409.7 mm (48.0 x 55.5 in)
- Weight: 317 kg (698 lb)

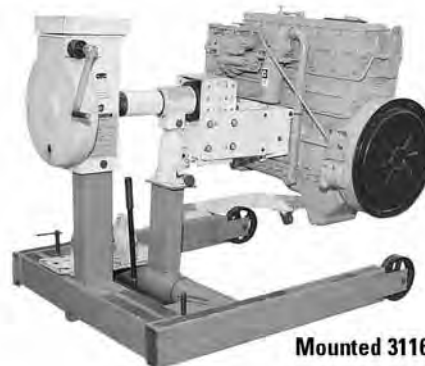

Mounted 3116 Engine

### Reference

Tool Guide, Lifting, Blocking and Clamping Section

Part Number	Description
1U-5750	Engine Repair Stand

### Engine Adapter Plates for 1U-5750

- Order only adapters needed for engines being worked on; universal adapter assembly required for mounting all but John Deere adapters to stand
- Warranty: Manufacturer's

### NOTE:

Products are shipped F.O.B. Searcy, Arkansas. Each Engine mounting plate includes all the necessary hardware and an engine application chart.



## 374-6393 Engine Mounting Adapter

Model Usage: CT660 Truck

Warranty: Manufacturer's

- Adapter for 1U-5750 Diesel Engine Repair Stand

Specifications	
Dimensions	26.85 x 18.25 x 11.5 in
Weight	70 lbs

Part Number	Description
374-6393	Engine Mounting Adapter

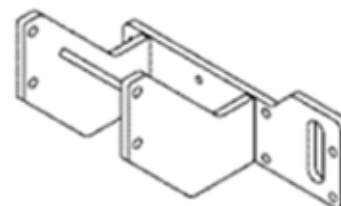

# Engine Lifting and Positioning

## Adapter Plates Sold Separately

Engine Tools

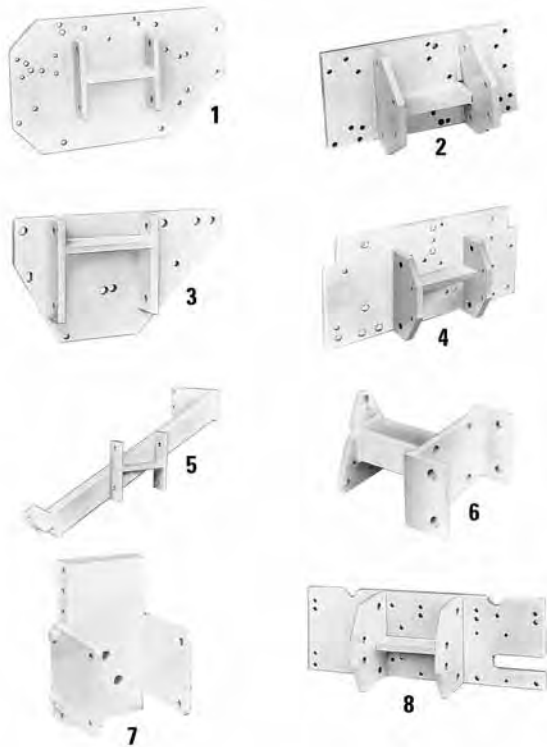

<b>Sold Separately</b>			
<b>Item</b>	<b>Part Number</b>	<b>Description</b>	<b>Model Use</b>
1 <sup>1</sup>	1U-7517	Adapter Plate	For International Harvester engines: DT-466 in-line 6-cylinder; DV-550, MV-404, MV-446, V304, V345, V392, 4-152, 4-196, 4-194, 9.0 liter V-8 and the 6.9 L (Ford). Wt., 28.1 kg (62.0 lb)
2 <sup>1</sup>	1U-7510	Adapter Plate	For Cummins engines: All NH, NTC and NTE 855 Series in-line 6-cylinder; 378 Series V-6; 504, 555 and 903 Series V-8; KT 1150 Series in-line 6-cylinder, L10. Wt., 18.6 kg (41.0 lb)
3 <sup>1</sup>	1U-7513	Adapter Plate	For Mack engines: V-8 1000 and 1980 thru current 672 in-line 6-cylinder and 477 Scania series. Note: No. 206629 supersedes No. 205100. Wt., 14.5 kg (32.0 lb)
4 <sup>1</sup>	1U-5749	Adapter Plate	For Cat <sup>®</sup> engines; Nos. 1673, 1674, 1693, 3304, 3306 and 3406 in-line 6-cylinder; Nos. 1100 and 3208 V-8; No. 3408 V-8. Wt., 30.8 kg (68.0 lb)
5 <sup>1</sup>	1U-7518	Adapter Plate	Allison transmission mounting plate, for use with 1750-A engine stand. Handles Allison transmission Nos. AT500, MT600, MT 6-speed, VH, VS and V730. Wt., 11.3 kg (25.0 lb)
7 <sup>1</sup>	1U-7509	Adapter Plate	For Detroit engines: 53 Series in-line 6-cylinder, 6V and 8V; 71 Series in-line 6-cylinder, 6V, 8V and 12V; 92 Series 6V and 8V; 8.2 liter V-8. Wt., 26.3 kg (58.0 lb)
<b>Not Shown</b>			
--	9U-5161	Adapter Plate	For Cat <sup>®</sup> Engines: 1.1 and 1.7, C11

<sup>1</sup>Must be used with universal adapter plate assembly

## FT2942 Transmission Support Assembly

Model: 924G and 928G Medium Wheel Loader

Warranty: None

- Used to mount transmission to an engine repair stand
- Used with 1U-5750 Engine Repair Stand

### Reference

Service Manual, 924G and 928G Power Train Disassembly and Assembly

Material for item 1	SAE 1020M steel
Material for item 2	ASTM A513 steel

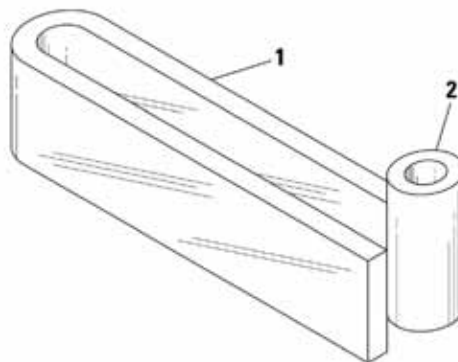

## 350-4401 Transmission Adapter

Model: CX28, CX31, CX35 Transmissions

Warranty: none

- Used to mount transmissions to engine repair stand
- Used with 1U-5750 Engine Repair Stand
- Supports transmission during disassembly and assembly

### References

KENR8152, CX31-P600 Petroleum Transmission Well Servicing, Disassembly and Assembly

KENR8128, CX35-P800 Petroleum Transmission and Petroleum Power Train Packages, Disassembly and Assembly

KENR5098, CX28 On-Highway Transmission, Disassembly and Assembly

Part Number	Description
350-4401	Transmission Adapter

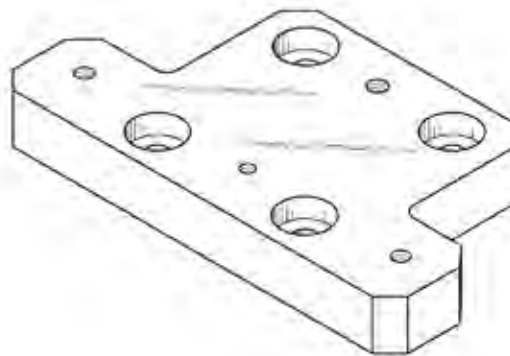

## 206-0030 Foot Plate

Model: 1U-5750 Rollover Stand

Warranty: Six Months

- Used to provide a place for operator to stand and/or a place for tools or parts
- Used with 1U-5750 Engine Repair Stand
- Enhances usability of rollover stand
- Specially shaped to fill in space between hydraulic jack and end post
- Coated with anti-skid material and painted with high visibility yellow paint
- Steel construction 9.5 mm (0.38 in) thick

### Installation Instructions

1. Installs without disassembling rollover stand.
2. Parking brake pins must be unscrewed and reinstalled when positioning plate.

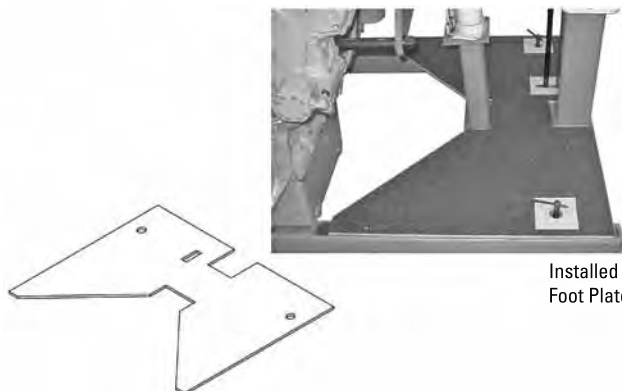

Installed Foot Plate

(Continued)

# Engine Lifting and Positioning

## 206-0030 Foot Plate (Continued)

Model: 1U-5750 Rollover Stand

Warranty: Six Months

Part Number	Description
206-0030	Plate

## 173-5533 Repair Bracket Assembly

### Essential Tool

Model: C-9 Engine

Warranty: Six Months

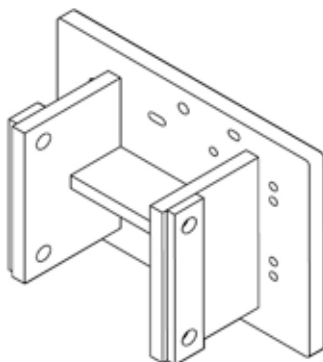

- Used to mount C-9 Engine on 1U-5750 Diesel Engine Repair Stand
- Using this bracket allows engine to be rotated 360 degrees
- Attaches in place of crankcase breather cover (breather cover must first be removed)

Part Number	Description
173-5533	Engine Stand Bracket

## 180-2877 Adapter Group

Model: MY2000 C-15 and C-16 Engines and 3406E Engines

Warranty: Six Months

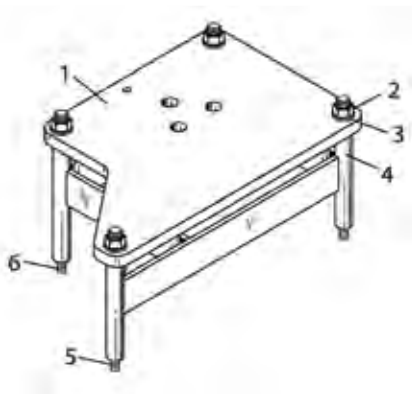

- Used to mount MY2000 C-15 and C-16 "Weight-Reduced" engines onto 1U-5750 Engine Repair Stand
- Allows 360 degree rotation of engine
- Attachment location minimizes number of components that must be removed
- Also fits 3406E Engines at the same attachment location

### Application Procedure

1. Remove filter assembly from inlet manifold side of engine.
2. Install discontinued 180-2874 Special Studs into two 3/4 inch threaded holes below head gasket joint.
3. Install discontinued 180-2873 Special Studs into two 3/4 inch threaded holes midway down cylinder block.
4. Screw studs in as far as possible (some may bottom-out before stud shoulder contacts cylinder block).
5. Install 180-2875 Spacer Assembly (not serviced), 180-2876 Plate (not serviced), and 5P-8248 Hard Washers.
6. Securely tighten 2J-3506 Full Nuts.
7. Attach 180-2876 Plate (not serviced) to head of 1U-5750 Engine Repair Stand.

(Continued)



## 180-2877 Adapter Group (Continued)

Model: MY2000 C-15 and C-16 Engines and 3406E Engines

Warranty: Six Months

Item	Part Number	Description
1	180-2876	Plate (Not serviced)
2	2J-3506	Nut
3	5P-8248	Hard Washer

Item	Part Number	Description
4	180-2875	Spacer Assembly (Not serviced)
5	205-9315	Special Stud (long)
6	205-9314	Special Stud (short)
--	180-2877	Adapter Group

## 179-9561 Mounting Bracket Group

Model: 950F Wheel Loader

Warranty: Six Months

- Used to mount transmission on 1U-5750 Engine Repair Stand
- Used with three 8L-3745 Socket Head Cap Screws to mount bracket to engine repair stand
- Used with four 1D-4622 Bolts to mount transmission to bracket
- Eyebolt allows bracket to be lifted in place with a hoist
- Provides safe handling of transmission during disassembly, maintenance, and assembly
- Allows 360 degree rotation for easy access and repair

Engine repair stand capacity	2721.6 kg (6000 lb)
------------------------------	---------------------

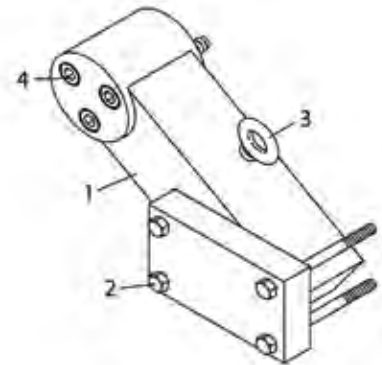

Item	Part No.	Description	Thread	Length
1	179-9561	Mounting Bracket Group	--	--
2	1D-4622	Bolt	3/4 - 10	203 mm (8 in)
3	3L-9168	Eyebolt	--	--

Item	Part No.	Description	Thread	Length
4	8L-3745	Socket Head Cap Screw	1 - 8	127 mm (5 in)

## 179-9562 Mount Bracket Assembly

Model: 924 Wheel Loader

Warranty: Six Months

- Used to mount transmission on 1U-5750 Engine Repair Stand
- Used with three 8L-3745 Socket Head Cap Screws to mount bracket to engine repair stand
- Used with four 8C-3413 Socket Head Cap Screws to mount transmission to bracket
- Provides safe handling of transmission during disassembly, maintenance, and assembly
- Allows 360 degree rotation for easy access and repair

Engine repair stand capacity	2721.6 kg (6000 lb)
------------------------------	---------------------

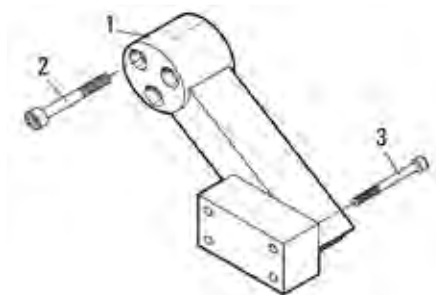

Item	Part Number	Description	Thread	Length
1	179-9562	Mount Bracket Assembly	--	--
2	8L-3745	Socket Head Cap Screw	1 - 8	127 mm (5 in)
3	8C-3413	Socket Head Cap Screw	M12 x 1.75	120 mm (4.7 in)

## FT0864 Jib Crane

Model: 773

Warranty: None



- Mounted underneath canopy of 773 Truck to lift tie-arch or engine components and deposit them on service truck
- Used with 9S-8535 Trolley and 8S-9906 Ratchet
- Can be used in other applications where a crane is not available

Capacity	227 kg (500 lb)
----------	-----------------

## FT1032 Mounting Group

Model: 621

Warranty: None



- Required when mounting 621 Tractor engines on former 9S-8500 Engine Stand
- Short bars installed on both sides of pan at rear of engine and long bar mounted across front

## 9U-7847 Bolt

Model: 3046 Diesel Engine

Warranty: Six Months



- Used to fasten 3046 Engine to engine stand for disassembly and assembly (4 bolts required)
- Used with 1U-9352 Engine Stand
- Provides a source for this special hard-to-find bolt (most common fine-threaded bolts are not long enough)
- Size: M10 x 1.25 x 90 mm (3.5 in)
- Metric bolt class (grade): 10.9

### Reference

SEN6458, Special Instruction, Disassembly and Assembly of 3046 Engines

Part Number	Description
9U-7847	Bolt

## 8F-2550 Engine Tilting Group

Model: D364, D375, D379, G379, D386, D397, D398, G398, D399, G399

Warranty: Six Months

- Used to remove and install crankshafts; refer to charts (many parts are part of 8F-2250 Engine Tilting Group)

Item	Description	Qty.
6	Spacer	
7	Upper Stud	4
17	Turn Buckle	4



Item	Part Number	Description	Qty.
1	8F-4228	Hinge Yoke	4
2	0L-1178 <sup>1</sup>	Bolt	4
3	8F-4235	Plate	2
4	8F-4233	Hinge Block	4
5	1D-4616	Hex Head Cap Screw Bolt	4
8	8F-4224	Pivot Bracket Assembly	4
9	8F-4225	Bolt	4
10	8F-4234	Upper Hinge Block	4
11	8F-4227	Hinge Yoke	4
12	5B-9385	Bolt	12
13	5F-9892 <sup>1</sup>	Coupling Pin (70 ton)	16

Item	Part Number	Description	Qty.
14	8F-4239	Hinge Block	4
15	8F-4226	Yoke	8
16	8F-4231	Lower Stud	4
18	8F-4230	Upper Stud	4
19	1B-4334 <sup>1</sup>	Nut	8
20	6F-7058	Pivot Bracket Nut	4
--	8F-2550	Engine Tilting Group	--
<b>Not shown</b>			
--	3B-4618	Cotter Pin	32
--	1B-4209	Nut - Full	2
--	0S-0107	Washer	12

<sup>1</sup> Discontinued, part of the 8F-2550 Engine Tilting Group

# Engine Lifting and Positioning

## 8F-2550 Engine Tilting Group Parts

Engine Tools

Part Number	No. Req'd D399, G399	No. Req'd D398, G398	No. Req'd D379, G379	Description	Length mm (in)	Thread Ends
FT0733-2	3	2	2	Stud	203,2 (8.00)	RH
FT0111	3	2	2	Stud	254,0 (10.00)	RH
FT0111-A	3	2	2	Stud	520,7 (20.5)	RH
FT0733-10	3	2	2	Stud	596,9 (23.5)	RH
FT0733-1	3	2	2	Stud	152,4 (6.00)	RH, LH
FT0733-5	3	2	2	Stud	292,1 (11.5)	RH, LH
FT0733-7	3	2	2	Stud	469,9 (18.5)	RH, LH
FT0733-9	3	2	2	Stud	546,1 (21.5)	RH, LH
	12	8	8	Block		
	6	4	4	Stud, 368, 3 mm (1 1/4in - 14 1/2in) L		
	6	4	4	Stud, 228, 6 mm (1 1/4in - 9 in) L		
	12	8	8	Yoke		
	6	4	4	Hinge Yoke		
	6	4	4	Hinge Block		
	2	2	2	Eyebolt 5/8 in		

## 8F-2550 Engine Tilting Group Parts (Continued)

Part Number	No. Req'd D399, G399	No. Req'd D398, G398	No. Req'd D379, G379	Description
5B-1181 <sup>1</sup>	6	4	4	Turnbuckle
FT0731	1			Support Beam, LH
FT0735	1			Support Beam, RH
FT0734	6	4	4	Support Beam
FT0736	6	4	4	Support Bracket
FT0732	2	2	2	Lifting Channel
FT0113A		1	1	Support Beam
FT0113		1	1	Support Beam
		2	2	Guide Pin, 254 mm (7/8 - NF) long
	2			Guide Pin 254 mm (1 in - NF, 10 in) long
	2	2	2	Small Hoist

<sup>1</sup> Discontinued, part of the 8F-2550 Engine Tilting Group

Part Number	No. Req'd: D399, G399	No. Req'd: D398, G398	No. Req'd: D379, G379	Description	Size
0S-1587	18	12	12	Bolt	12.7 - 44.45 mm (1/2 - 1 3/4 in) long
1B-4334 <sup>1</sup>	12	8	8	Nut	1 1/4in
5F-9892 <sup>1</sup>	30	20	20	Coupling Pin (70 ton)	--
3B-4618	60	40	40	Cotter Pin	--
1D-4609	12	8	8	Bolt	19.05 - 76.2 mm (3/4 - 3 in) long
1A-5964	12	8	8	Bolt	9.53 - 114.3 mm (3/8 - 4.5 in) long

(Continued)

## 8F-2550 Engine Tilting Group Parts (Continued) (Continued)

Part Number	No. Reqd: D399, G399	No. Reqd: D398, G398	No. Reqd: D379, G379	Description	Size
1D-4717	12	8	8	Nut	9.53 mm (3/8 in)
6V-6546	6	4	4	Bolt, 1/2-13 x 356 mm (14 in) long	12.7 - 342.9 mm (1/2 - 13.5 in) long
8F-4225	6	4	4	Bolt	19.05 - 254 mm (3/4 - 10 in) long
0L-1178 <sup>1</sup>	6	4	4	Bolt	19.05 - 50.4 mm (3/4 - 2 in) long
4B-4281	2	2	2	Washer	--
1D-4720	2	2	2	Nut	5/8 in
8F-4423	2	2	2	Lifter - Flywheel	--

<sup>1</sup> Discontinued, part of the 8F-2550 Engine Tilting Group

## Fabricated Tools used with the 8F-2550 Engine Tilting Group

Part Number	Description
FT0113	Support Beam, LH
FT0113A	Support Beam, RH
FT0731	Support Beam, LH
FT0735	Support Beam, RH

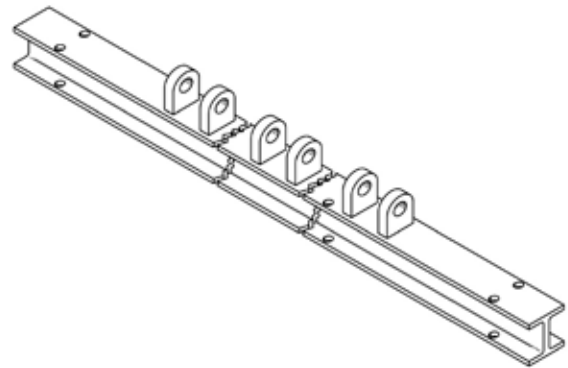

## Support Beam

Part Number	Description
FT0734	Support Beam

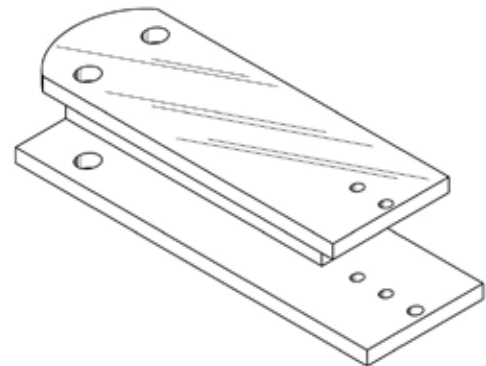

# Engine Lifting and Positioning

## Studs

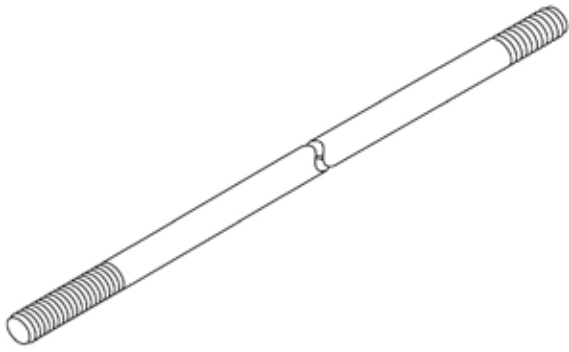

Part Number	Description
FT0111	Stud
FT0111A	Stud
FT0733	Stud

## Support Bracket

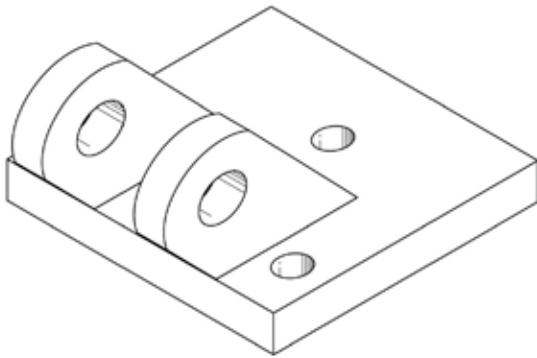

Part Number	Description
FT0736	Support Bracket

## Lifting Channel

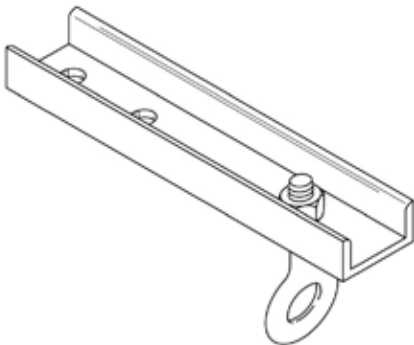

Part Number	Description
FT0732	Lifting Channel

## FT2972 Engine Adapter

Model: 303C CR Mini Excavator

Warranty: None

- Used to remove and install engine
- Used with 6V-2082 Hook Group
- Adapter prevents front and rear engine lifting chains from slipping while lifting with an overhead lifting device

### Reference

REN5585, 303C CR Excavator Disassembly and Assembly

Maximum lifting capacity	136 kg (300 lb)
Item 1 material	MC3 x 7.1 channel ASTM A-36 steel
Item 2 material	ASTM A-36 steel

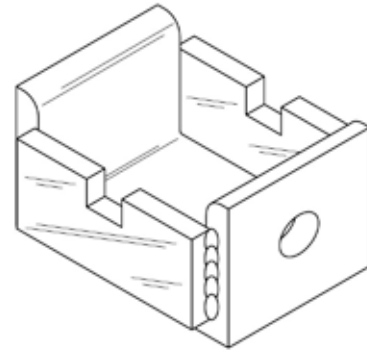

## FT0962 Ladder

Model: 773

Warranty: None

- Makes 773 engine components accessible for in-chassis removal and installation
- Telescoping hooks adjustable to fit truck frame

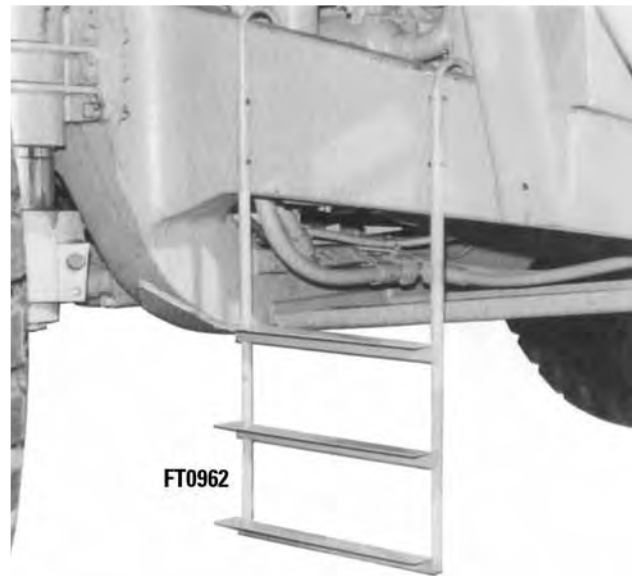

## FT2792 Engine Lift Bracket

Model: 3512 Engine

Warranty: None



- Used to lift the engine out of the D10R track-type tractor using 2 normal lift points at front of engine and this bolt-on bracket at rear of engine
- Bracket mounts to top, rear side of engine (use bolts supplied with engine)
- Only 1 bracket required

## Motor Grader Rear Engine Support Groups

Model: All G-Series Motor Grader Engines

Warranty: Six Months

- Used to service all G-Series Motor Grader engines
- Allow removal of motor grader transmission without removing engine
- Saves about 4 hours of labor
- Motor grader model serial number listed in chart coincides with release of load sensing hydraulic systems, threaded gland hydraulic cylinders, and corporate electrical systems
- Contain 2 support assemblies which bolt to both sides of flywheel housing to support engine; forcing bolt and locknut properly position support assembly, which is attached to rear of engine, against top surface of motor grader frame

Model	Serial Number	Tool Group
12G	61M-12027 & Up	A
	3WC1067 & Up	A
14G	96U-7046 & Up	D
	3L193 & Up	D
16G	93U-2679 & Up	E
120G	87V-8360 & Up	C
	11W-1251 & Up	C
	61W591 & Up	C
	2AB62 & Up	C
130B	74V-2321 & Up	B
	12W-1082 & Up	B
	59K82 & Up	B
140G	72V-10334 & Up	A
	13W741 & Up	A
	50H-1261 & Up	A
160G	4JD141 & Up	A

(Continued)



## Motor Grader Rear Engine Support Groups (Continued)

Model: All G-Series Motor Grader Engines

Warranty: Six Months

Part Number	Description	Qty.
<b>Engine Support Group A<sup>1</sup></b>		
4N-7862	Support Assembly, Right	1
1D-5118	Jam Nut	2
8H-6508	Forcing Bolt	2
0S-1595	Bolt	8
4B-4280	Washer	8
<b>Engine Support Group B<sup>2</sup></b>		
1D-5118	Jam Nut	2
8H-6508	Forcing Bolt	2
7B-3235	Bolt (English)	4
<b>Engine Support Group C<sup>3</sup></b>		
1D-5118	Jam Nut	2
8H-6508	Forcing Bolt	2
0S-1595	Bolt	8

Part Number	Description	Qty.
<b>Engine Support Group D (Use 3 washers between support assembly and flywheel housing at each 7K-4370 bolt)</b>		
2P-8913	Support Assembly	2
1D-5118	Jam Nut	2
8H-6508	Forcing Bolt	2
7K-4370	Bolt	4
4B-5275	Washer	12
<b>Engine Support Group E (Use shims as required between support assembly and flywheel housing at both support locations)</b>		
4N-7358	Support Assembly	2
1D-5119	Jam Nut	2
4B-6208	Forcing Bolt	8
8S-9092	Bolt	4
4N-6063	Shim	12

<sup>1</sup> Includes: Support Assembly, Left, Qty. 1

<sup>2</sup> Includes: Support Assembly, Qty. 2

<sup>3</sup> Included: Support Assembly, Qty. 2

## 326-5851 Adjustable Engine Stand

### Essential Tool

Model: C175 Engine

Warranty: Six Months

- Used to support C175-16, C175-20, and 797 Off-Highway Truck retro-fit engines for storage, shipping, and reconditioning
- Used with 323-1146 Lifting Group — attaches to engine stand mounting brackets (for lifting and moving stand with engine installed)
- Has built-in lift truck pockets for moving empty stand only (not to be used to move stand while engine is installed)
- Steel wheels on one end of stand allows engines to be loaded/unloaded from shipping containers
- Stand segments unbolt and expand to fit larger C175-20 engine
- Stackable design allows empty stands to be stored in less space

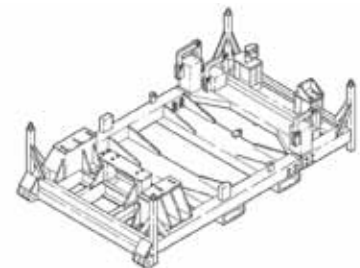

Length (closed)	3831mm (150.8 in)
Width	2299 mm (90.5 in)
Height	1073 mm (42.2 in)
Weight	2196 kg (4842.0 lb)

Part Number	Description
326-5851	Adjustable Engine Stand

## 368-0005 Lifting Bracket

### Essential Tool

Model Usage: Skid Steer Loaders

Warranty: Six Months

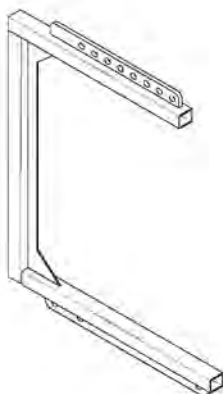

European Union compliant, CE marked

- Used to remove and install 3034, 3024C, and 3044C Engines
- Used with an overhead lifting device
- Top rail of bracket has multiple lifting points for center-of-gravity adjustments
- Bottom rail has three lifting points for various engines

#### Reference

NEHS1113, Tool Operating Manual

Part Number	Description	Working Load Limit	Overall Size	Weight
368-0005	Lifting Bracket	340 kg (750 lb)	79 x 112 cm (31 x 44 in)	24 kg (53 lb)

## 795F AC Engine Rail System

Model Usage: 795F AC

Warranty: Six Months

European Union compliant, CE marked

- Used to support the C175 engine during removal and installation in the 795F AC Off-Highway Truck
- Includes rear and front rail tool groups and various support brackets that are used with both groups
- Rear rail tool group can be used independently without using the front rail tool group
- Due to overhead obstruction, rails allow engine to be rolled forward and backward for removal and installation

#### Reference

NEHS1096, Tool Operating Manual

KENR8726, 795F AC Off-Highway Engine Supplement

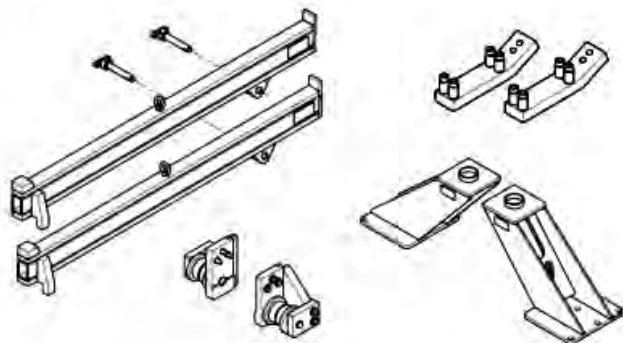

335-1617

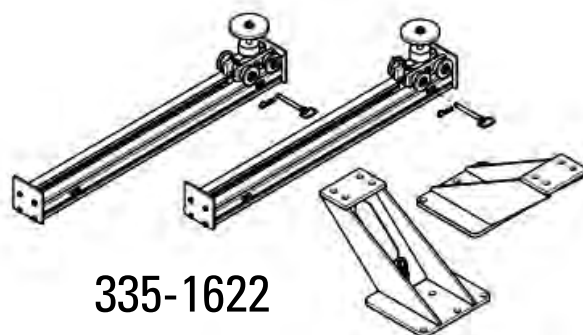

335-1622

Part Number	Description	Weight
335-1617	Rear Rail Group	42 kg (92 lb)
335-1622	Front Rail Group	158 kg (349 lb)

## 394-0867 793F AC Engine R&I Rail Tool Group

Model Usage: 793F AC

Warranty: Six Months

- Used to support the C175 engine during removal and installation
- Allows removal and installation of engine without removing electrical cabinet off the machine
- Used with Front Rails that are part of the 335-1622 Front Rail Group

### Reference

NEHS1096, Tool Operating Manual

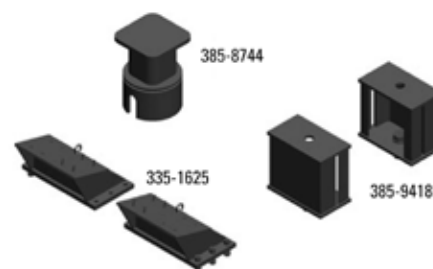

Part Number	Description	Weight
394-0867	793F AC Engine R&I Rail Tool Group	--
Specifications		
335-1625	Mounting Bracket Group	98 kg (216.1 lb)
385-8744	Lift Cap Assembly	10 kg (22.0 lb)
385-9418	793F AC Front Rail Tool Group	41 kg (90.4 lb)

**8T-9209 Turbocharger Blocking Tool**

Model: 3600 Engines

Warranty: Six Months

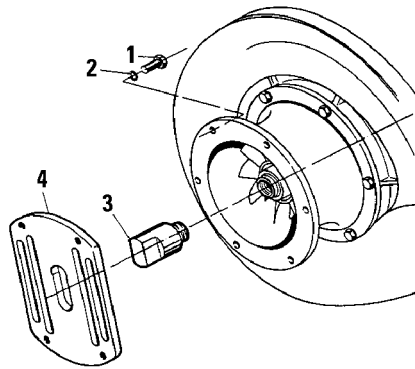

- Prevents rotation of turbocharger impeller (allows emergency engine operation at reduced power)
- When rotation of turbocharger is prevented, air flow through turbo is maintained and lubricating oil flow must be stopped; (for procedure to stop lubricating oil, refer to Special Instruction SEHS8704) The output power of the engine must then be limited so exhaust gas temperature at cylinders does not exceed 480° C (900° F)
- To stop rotation, disconnect air inlet; install key (3) into impeller bushing; secure with plate (4)

Item	Description
3	Key
4	Plate

Item	Part No.	Description	Size	Qty.
1 <sup>1</sup>	0S-1595	Bolt	1/2 - 13 x 11/4 inL	4
2 <sup>1</sup>	0S-1593	Lock Washer	--	4

<sup>1</sup> Items are not part of 8T-9209

**137-7024 Turbocharger Wash Group**

Model: 3600 Engines

Warranty: Six Months

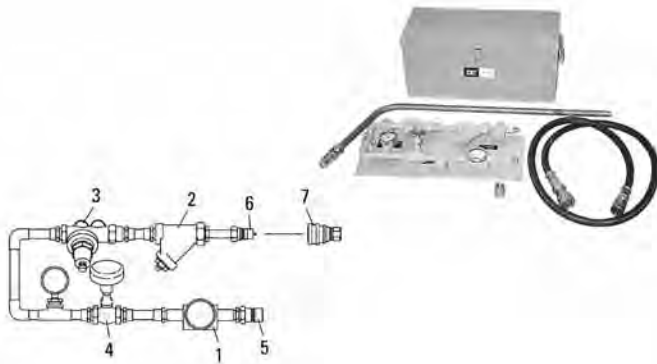

- Used to remove deposits which form on the diffuser and turbine blades when an engine is operated on heavy fuels
- Washer provides cleaner turbines resulting in increased performance of turbocharger
- Use only with fresh, clean water (additives, solvents, salt, and dirt in water tend to form deposits on diffuser and turbine blades)

Item	Part Number	Description
1	130-3298	Flow Meter
2	130-3299	Screen
3	130-3300	Regulating Valve
4	130-3301	Needle Valve

Item	Part Number	Description
5	130-3295	Quick Disconnect Nipple
6	130-3296	Quick Disconnect Nipple
7	130-3297	Quick Disconnect Coupler
8	129-4891	Hose Assembly
--	137-7024	Turbocharger Wash Group

**4C-8769 Valve Seat Driver**

Model: 3600 Engines  
Warranty: Six Months

- Used to install water-cooled valve seat inserts
- Serves as guide and driver, helping to prevent insert damage during installation and ensuring insert is uniformly installed in cylinder head
- Overall length: 355.0 mm (14.0 in )
- Diameter of knurl handle: 65.0 mm (2.5 in )

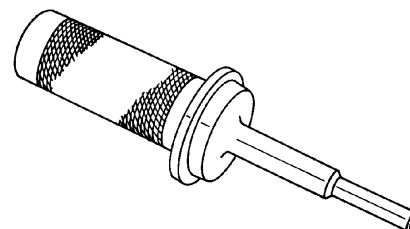

Part Number	Description
4C-8769	Valve Seat Driver

**200-5958 Wear Sleeve Installer, 1U-6241 Seal Installer  
121-7705 Stud Assembly, 121-7700 Distorter Block**

Model: 3600 Engines  
Warranty: Six Months

- Used to remove and install crankshaft wear sleeve — essential to correctly remove and install sleeve without damage to sleeve or crankshaft
- 1U-6241 installs seal after wear sleeve is installed

**Removal**

- Use the 121-7700 Distorter Block with 5P-7409 Distorter
- Distorter block bolts directly to engine housing using one of the cover mounting holes and bolt
- Tools work together to make an indentation in the sleeve (helps to loosen sleeve from crankshaft)
- Distorter tool is rotated between distorter block and wear sleeve to create an indentation in the metal (similar to using a hammer and chisel to make the indentation)
- Making four indentations around the crankshaft wear sleeve should allow sleeve to easily slide off crankshaft

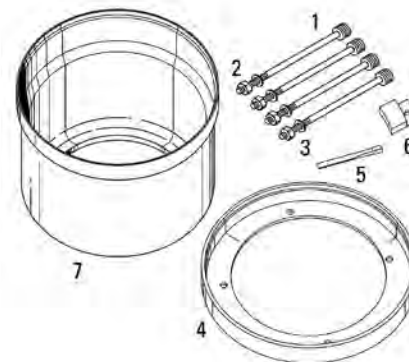
**Installation**

1. Install wear sleeve in installer.
2. Thread four studs into crankshaft.
3. Install sleeve and installer onto studs.
4. Install washers and nuts.
5. Tighten nuts to pull wear sleeve onto crankshaft.
6. When inside face of installer bottoms against end of crankshaft, sleeve is installed to correct depth.
7. Install seal.

**Reference**

SENR3594, Service Manual Module, Disassembly and Assembly

Item	Part Number	Description	Size
1	121-7705	Stud Assembly	Threads on large end: 11/8 - 12, Threads on small end: 1/2 - 13
2	1F-7958	Full Nut (1/2 - 13) (fork mounting hardware)	1/2-13
3	5P-8245	Hard Washer	--
4	200-5958	Wear Sleeve Installer	--
5	5P-7409	Sleeve Distorter	--
6	121-7700	Distorter Block	--
7	1U-6241	Seal Installer	--

## 4C-6593 Valve Lash Tool

Model: 3600 Engines

Warranty: Six Months

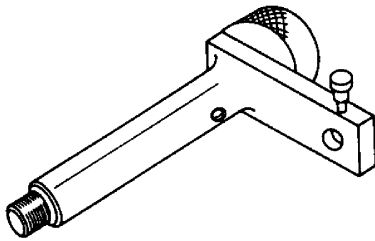

- Used to easily check and adjust valve lash clearance of intake and exhaust valve
- Part of 4C-6594 Timing and Fuel Setting Tool Group
- Used with 6V-3075 Dial Indicator and 8S-3675 Contact Point (parts of 4C-6594 Tool Group); both can be secured in valve lash tool by tightening nylon thumb screw
- 11.11 cm (4 3/8 in) fabricated steel bracket with:  
1/4 - 24 plastic thumb screw to hold a dial indicator in place  
3/8 - 16 bolt with 38.1 mm (1 1/2 in) diameter knurled knob for ease of installing to valve rocker cover base

Part Number	Description
4C-6593	Adjusting As - Valve Lash

## 4C-6585 Cylinder Pressure Measuring Indicator Group, 3000 psi

Model: 3600 Engines

Warranty: Manufacturer's Six Months



- Troubleshooting tool used to check cylinder pressure on 3600 Family Diesel Engines
- Easily provides relative average peak cylinder pressure on running engine
- Not recommended for use on other than diesel engines because static pressure indication would require too much tapping to bring pointer to correct reading
- Used with 7E-1699 Manual Valve Group designed so any movement of valve stem due to engine vibration tightens valve stem against its seat; prevents valve from accidentally opening during engine operation
- K-107 cylinder pressure indicator manufactured by Kiene Diesel Accessories, Inc.
- Equipped with 3 1/2 inch Zytel nylon Bezel and case, threaded Bezel, Bourdon tube gauge, dual range 0 through 3000 psi and 0 through 210 kg/cm<sup>2</sup>, metal case and service tool
- Kiene AX-13A standard indicator connection (M) by 1 1/16-10 Whitworth (F), wing nut and plug, 45° bend, 15.2 cm (6 in) long

### Repair and Service

Kiene Diesel Accessories, Inc.  
325 So. Fairbanks Street  
Addison, IL 60101

Phone: 708-543-5950

Fax: 708-543-5953

Part Number	Description
4C-6585	Cylinder Pressure Measuring Indicator Group

**4C-6987 Socket**

Model: All 3600 Engines except 3618

Warranty: Six Months

Part Number	Description
4C-6987	Socket

- Used for removal and installation of cylinder head nuts
- Saves time by installing nuts prior to use of tensioners and removing nuts after releasing torque
- Used with hydraulic stud tensioners of 4C-5858 Tool Group
- Maximum torque: 340 N·m (250 ft·lb)

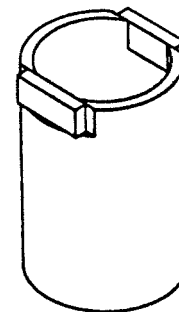
**184-3131 Cylinder Head Stud Socket Assembly**

Model: 3618 Engines

Warranty: Six Months

Part Number	Description
184-3131	Cylinder Head Stud Socket Assembly

- Used to quickly remove and install cylinder head nuts after tensioning is released
- Also known as a nut spinner

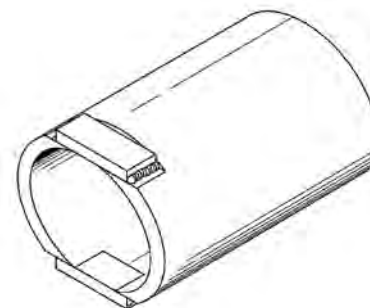
**4C-9839 Safety Retainer Group**

Model: 3600 Engines

Warranty: Six Months

- Used for disassembly and assembly of cylinder head assembly
- Steel strap safety retainer for pulling rod in case pulling rod accidentally breaks
- Fits around 316-1493 Hydraulic Puller Assembly (fastened to bottom with 2 screws)
- If the pulling rod accidentally breaks and the retainer becomes deformed, the retainer should be replaced.
- Dimensions (thickness x width x length): 3.175 x 44.45 x 290 mm ( 1/8 x 1 3/4 x 11.4 in) long (length allows full stroke of 316-1493 Puller Assembly)

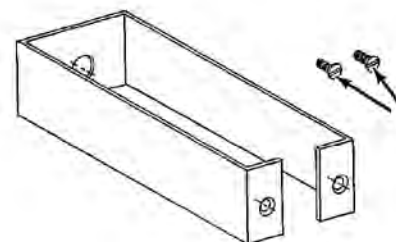

Item	Part Number	Description
1	2M-5139	Screw (2)
--	4C-9839	Safety Retainer Group

## 130-6993 Injector Seat Cleaning Brush

Model: 3600 Engines

Warranty: Six Months

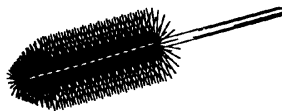

- Used to clean injector bore seats (also part of 9U-5106 Diesel Tool Group)
- Used with 1/4 inch drive drill
- Made of stainless steel — provides best cleaning results without causing damage to injector bore seat (other brushes may not have the stiffness to clean or be too stiff and cause damage)

Overall length	31.8 cm (12.5 in)
Brush diameter	47.6 mm (1.88 in)
Wire diameter	0.25 mm (0.010 in)

Part Number	Description
130-6993	Injector Bore Brush

## 130-2534 Bridge Dowel Gauge

Model: 3600 Engines

Warranty: Six Months

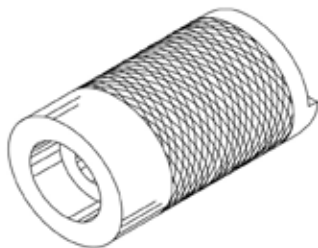

- Used to check straightness and projection of 4W-5441 Bridge Guide Dowel
- Bridge dowels that are not straight will not go through gauge and must be replaced (fast and easy method of determining reusability)
- Also used to check projection of dowel above cylinder head
- Gauge quickly and accurately measures  $105 \pm 2$  mm ( $4.1 \pm 0.08$  in) height requirement for bridge guide dowels
- Inside diameter: 19.09 mm (0.752 in)

Part Number	Description
130-2534	Bridge Dowel Gauge

## Valve Guide Gauges

Model: 3600 Engines

Warranty: Six Months



- Used to check wear and correct installation of valve guide
- 9U-6401 Gauge quickly gives use again or do not use again status of valve guides
- 9U-6399 Gauge used to check newly installed valve guides (passing gauge through valve guide determines straightness (deformation) of inside diameter and shows if an area is below minimum diameter)

Part Number	Description	Diameter x Length (Go)	Diameter x Length (No-Go)
9U-6401	Valve Guide Gauge	16.106 x 50.8 mm (0.634 x 2.0 in)	16.209 x 50.8 mm (0.6381 x 2.0 in)
9U-6399	Valve Guide Gauge	16.003 x 175 mm (0.630 x 6.9 in)	16.059 x 50.8 mm (0.6322 x 2.0 in)



**1U-9570 Dowel Puller Group**

Model: 3600 Engines

Warranty: Six Months

- Used for pulling 15.875 mm ( 5/8 in) and 19.05 mm ( 3/4 in) dowels
- Makes the job quick and easy

Stand height	88.9 mm (3.5 in)
Shaft length	452.6 mm (17.81 in)
Slide hammer weight	2.72 kg (6 lb)

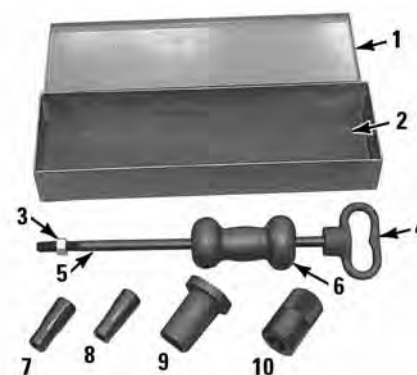

Item	Part Number	Description
1	1U-9568	Metal Box (not serviced)
10	1U-9577	Forcing Collar
2	1U-9569	Foam Block (not serviced)
3	8T-9413	Nut (not serviced)
4	1U-9571	Handle
5	1U-9574	Shaft

Item	Part Number	Description
6	1U-9575	Slide Hammer
7	1U-9573	Extractor, 19.05 mm (3/4 in)
8	1U-9572	Extractor, 15.875 mm (5/8 in)
9	1U-9576	Dowel Retriever Stand
--	1U-9570	Dowel Puller Group

**229-3639 Overhaul Protection Kit**

Model: 3600 Engines

Warranty: Six Months

- Each kit contains enough plastic protective covers and plugs for one cylinder
- Easily installed and quickly removed
- Protect fuel lines and openings in cylinder head from dust and dirt and serve as moisture seal while engine is overhauled
- 4 plastic web sleeves in each kit reduce impact damage to threads of cylinder head studs

Part Number	Description	Quantity
229-3639	Overhaul Protection Kit	--
<b>Service/Repair Parts</b>		
6P-6605	Plug, intake hole in block	1
7H-2902	Protective Plug, water jacket in block	4
4C-9517	Protective Plug, injector hole in head	1
4C-9518	Protective Plug, 3/16 - 16 thd, fuel lines	4
4C-9519	Protective Cap, 3/16 - 16 thd, fuel line connectors on head and block	4
4C-9521	Protective Cap, 9/16 - 18 thd, oil line connectors in head and block	2
4C-9524	Protective Web Sleeve, threads on cylinder head studs	4
229-3608	Protective Plug, Cylinder Liner and Bore	2
229-3611	Rod Journal Cover	1

## 128-5113 Thread Repair Insert

Model: 3600 Engines

Warranty: Six Months

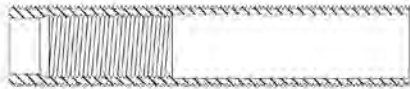

- Replaces discontinued 4C-6409 Thread Repair Insert
- Used to repair stud holes with damaged threads (only one of four holes per head can be repaired using this insert)
- Install by drilling damaged hole to 23.41 mm (1 59/64 in) and threading hole using a 2-12 tap
- Threaded repair insert is locked into place with 9S-3265 Retaining Compound

### Reference

SEBF8151, Guideline for Reusable Parts

Outside thread	2-12
Inside thread	1 5/8 - 12
Overall length	270.0 mm (10.6 in)
Drill	4C-6415 Drill
Tap with pilot	4C-6417 Tap
Extension tap	4C-6416 Tap

Part Number	Description
128-5113	Thread Repair Insert

## Ring Groove Gauges

Model: 3600 Engines

Warranty: Six Months



- Used to check piston ring groove wear to determine reusability of piston
- Simple to use. If the scribe line is visible, then the piston ring groove is good. If the line is not visible, then the piston is nonreusable.
- Three separate gauges (checks all four piston ring grooves)
- Gauges clearly marked with "top and second ring", "third ring", and "oil ring" for easy identification
- Made from heat treated steel for better wear resistance
- Size (L x W): 75 x 19 mm (3.0 x 0.8 in)

Part Number	Description
1U-9029	Ring Groove Gauge (oil ring)
1U-9030	Ring Groove Gauge (third ring)
4C-3654	Ring Groove Gauge (top and second ring)

Part Number	Description
<b>Not shown</b>	
197-3710	Ring Groove Gauge (top and second ring), 3618 only

### 133-1531 Threaded Insert

Model: 3600 Engines with Turbochargers

Warranty: Six Months

- Used to repair stripped or damaged threads in turbocharger housings
- Used with 4C-9730 Tap and 8T-2793 Installation Tool
- Will withstand 540° C (1000° F) temperatures
- Thread specification: M10 x 1.5



Part Number	Description
133-1531	Threaded Insert

### 9U-5107 Spark Ignited Tool Group

Model: 3600 Series Spark Ignited Engines

Warranty: Six Months

Part Number	Description
9U-5107	Spark Ignited Tool Group
<b>The 9U-5107 Group consists of the following tools (each is discussed separately)</b>	
369-2607	Digital Indicator
4C-4601	Spark Plug Socket
4C-6593	Adjusting As - Valve Lash
4C-8568	Liner Puller Group
4C-8995	Ring Expander Group
4C-9043	Compressor Group
5P-4160	Point - Indicator Contact, 19.05 mm (0.75 in) long
9U-5156	Cleaning Tool Group

### 4C-8568 Liner Puller Group (part of 9U-5107 Group)

Model: 3600 Spark Ignited Engines

Warranty: Six Months

- Used to remove and install cylinder liner using hydraulic pressure (hoist attaches to puller to easily handle tool and cylinder liner)
- Hydraulic pump connects to two hydraulic puller assemblies for a combined pulling force of 11 tons at 34,474 kPa (5000 psi)
- Used with 3S-6224 Hydraulic Pump (115 Volt) or 8S-8033 Hydraulic Pump (230 Volt); other required tooling is 8T-3035 Lines Group and 8T-0820 Pressure Gauge

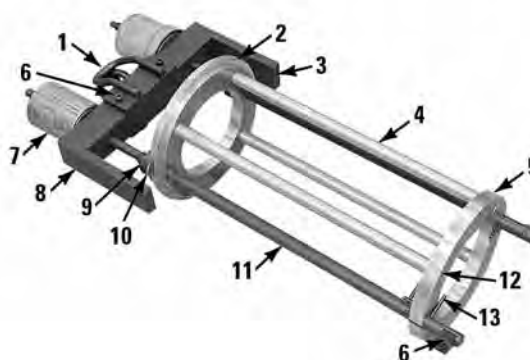

#### References

SENR4255, Service Manual

SENR5500, Service Manual

Item	Part Number	Description	Qty.
1	8T-2835	Lifting Bracket	--
2	4C-8565	Top Ring	--
3	6V-7078	Support Bridge	2

Item	Part Number	Description	Qty.
4	6V-7069	Rod Spacer	4
5	4C-8566	Bottom Ring	--
6	2J-5245	Bolt - Hex Socket Head	4

(Continued)

## 4C-8568 Liner Puller Group (part of 9U-5107 Group) (Continued)

Model: 3600 Spark Ignited Engines

Warranty: Six Months

Item	Part Number	Description	Qty.
7	316-1493	Hydraulic Puller Group	2
8	6V-7079	Bridge	--
9	8T-2836	Nut	2
10	4B-5278	Washer	2
11	299-5231	Leg Assembly	2
12	4D-3120	Bolt	8

Item	Part Number	Description	Qty.
13	4H-6996	Spring Pin	8
--	4C-8568	Liner Puller Group	--
<b>Not shown</b>			
--	4B-5276	Bolt Washer	2
--	2K-6073	Bolt	4
--	1B-4331	Nut	2

## 4C-8995 Ring Expander Group (part of 9U-5107 Group)

Model: 3600 Spark Ignited Engines

Warranty: Six Months



- Used to remove and install piston rings without damage to rings or piston
- Designed to fit 30 cm (11.8 in) piston rings

Part Number	Description
4C-8995	Ring Expander Group

## 4C-9043 Piston Ring Compressor Group (part of 9U-5107 Group)

Model: 3600 Spark Ignited Engines

Warranty: Six Months



- Used to install piston and connecting rod assemblies
- Band-type ring compressor for 30 cm (11.8 in) piston
- Over-center adjustable lock
- Proper seating of band assembly on cylinder liner to minimize possibility of ring breakage
- 4 tabs for support while securing to piston
- 2 handles for easier positioning of piston and rings

### References

SEN4255, Service Manual

SEN5535, Service Manual

Item	Part Number	Description
--	4C-9043	Compressor Group
1	6V-4027	Handle Assembly

## 9U-5156 Cleaning Tool Group (part of 9U-5107 Group)

Model: 3600 Spark Ignited Engines

Warranty: Six Months



- Used to clean prechamber seats on cylinder heads
- Used with 3/8 inch drive speed handle (easily removes rust with 10 to 20 turns of handle)
- Pilot helps to keep tool aligned

Extension length	23 cm (9.0 in)
Major OD	78 mm (3.0 in)
Drive end	3/8 in square (female)
Extension end	1/4 - 20 thd

(Continued)

**9U-5156 Cleaning Tool Group (part of 9U-5107 Group) (Continued)**

Model: 3600 Spark Ignited Engines

Warranty: Six Months

Item	Part Number	Description
1	150-5431	Pad Cut Down Disc <sup>1</sup>
2	150-5483	EXL Unitized Roloc Disc
3	1U-9023	Pilot Assembly
--	9U-5156	Cleaning Tool Group

<sup>1</sup>Warranty: Manufacturer's, 120-Day**9U-5105 Basic Tool Group**

Model: 3600 Engines

Warranty: Six Months

Part Number	Description	Qty	Part Number	Description	Qty
9U-5105	Basic Tool Group	--	<b>The 9U-5105 Group consists of the following tools (each is discussed separately) (Continued)</b>		
<b>The 9U-5105 Group consists of the following tools (each is discussed separately)</b>			8T-0970	Camshaft Bearing Tool Group	--
1F-7958	Full Nut (1/2 - 13) (fork mounting hardware)	--	8T-3022	Rod Guide Group	--
1P-7405	Eyebolt	--	8T-3029	Camshaft Segment Support Group	--
1P-7407	Eyebolt (1/2 - 13)	--	8T-3034	Water Pump Seal Driver	--
1P-7409	Eyebolt	--	9U-5932	Extension Camshaft Torque	--
1U-8692	Piston Pin Guide	--	9U-5981	Snap Ring Retainer	--
1U-9392	Damper Guide Pin	2	9U-6244	Support	--
1U-9393	Damper Guide Pin	2	9U-6248	Guide Bolt	3
1U-9824	Tool Group	--	9U-6251	Suspension Yoke Assembly	--
4C-6173	Fuel Drain Tray Assembly	--	9U-6461	Phoenix Screwdriver	--
4C-6357	Guide Group	--	121-7700	Distorter Block	--
235-0632	Cylinder Installation Tool Group	--	121-7705	Stud Assembly	--
4C-9426	Damper Guide Pin	--	126-6918	Head Lifting Bracket	--
4C-9451	Idler Rear Wrench	--	126-6919	Head Lifting Bracket	--
4C-9452	Idler Rear Wrench	--	126-6920	Handle Rod	--
4C-9818	Hex Shank	--	134-0932	Main Bearing Driver	--
4C-9819	Universal Joint	--	136-1452	Internal Pliers Assembly	--
5D-1972	Bolt (2)	--	138-7573	Bracket Assembly - Link	2
5P-7409	Sleeve Distorter	--	138-7574	Link Bracket	2
5P-8245	Hard Washer	--	138-7575	Bracket - Link	2
8T-0890	Puller Group	--	145-5190	Piston Support Group	--
8T-0914	Flywheel Guide Pin	2	191-1135	Cylinder Space Assembly	2
8T-0960	Handling Tool Group	--	200-5958	Wear Sleeve Installer	--

## 9U-5105 Basic Tool Group for Miscellaneous Tools 8T-3034 Water Pump Seal Driver (Part of 9U-5105 Group)

Model: 3600 Engines  
Warranty: Six Months

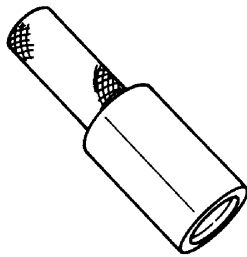

- Used to seat ceramic ring and rubber seat into water pump housing (knurled handle for better grip)
- Also installs carbon seal onto pump shaft (pressed onto shaft until light contact with ceramic seal face is made)
- Length: 210.0 mm (8.3 in)
- Seal diameter: 63.0 mm (2.5 in)

### References

SENR3594, Service Manual Module of SENR3590 Service Manual  
SENR3600, Service Manual Module of SENR3595 Service Manual  
SENR4259, Service Manual Module of SENR4255 Service Manual

Part Number	Description
8T-3034	Water Pump Seal Driver

## 1U-9824 Oil Drain Tool Group (Part of 9U-5105 Group)

Model: 3600 Engines  
Warranty: Six Months



- Used to drain oil from filter housing (keeps engine clean, captures all used oil, reduces cleanup cost)
- 9U-9822 and 9U-9821 Trays catch oil; 5N-5566 Hose routes it to a container (trays attach to filter housing with four 9S-8752 Nuts)
- 1U-9823 Scoop provides convenient way to carry used filters to a disposal area (filter is also too hot to handle without scoop)
- Allows filter replacement while engine is running
- Drain trays and scoop made from heavy-gauge sheet metal
- Scoop diameter: 203 mm (8.0 in)

### References

SENR3594, Service Manual Module of SENR3590 Service Manual  
SENR3600, Service Manual Module of SENR3595 Service Manual  
SENR4259, Service Manual Module of SENR4255 Service Manual

Item	Part Number	Description	Qty.
1	1U-9823	Filter Scoop Assembly	--
2 <sup>1</sup>	9S-8752	Nut - Full (3/8 - 16)	2
3	1U-9822	Tray Assembly, Upper	--
4	1U-9821	Tray Assembly, Lower	--
5 <sup>1</sup>	5N-5566	Hose (not part of 4C-6173)	--
--	1U-9824	Tool Group	--

<sup>1</sup> Not part of 1U-9824

**4C-6173 Fuel Drain Tray Assembly (Part of 9U-5105 Group)**

Model: 3600 Engines  
 Warranty: Six Months

- Used to drain fuel from filter housing (keeps engine clean, captures all fuel, reduces cleanup costs)
- 7V-0198 Hose and 4C-6173 Tray catches fuel; 5N-5566 Hose routes it to a container (tray attaches to filter housing with two 4F-4879 Bolts)
- 1U-9823 Scoop, from 1U-9824 Oil Drain Tool Group, provides convenient way to carry used filters to a disposal area
- Allows filter replacement while engine is running
- Drain tray made from heavy-gauge sheet metal with 25 mm (1.0 in) spout

**References**

SENR3594, Service Manual Module of SENR3590 Service Manual  
 SENR3600, Service Manual Module of SENR3595 Service Manual  
 SENR4259, Service Manual Module of SENR4255 Service Manual

Item	Part Number	Description
1	7V-0198	Hose (not part of 4C-6173)
2	4F-4879	Bolt, (2) (not part of 4C-6173)
3	4C-6173	Fuel Drain Tray Assembly
4	5N-5566	Hose (not part of 4C-6173)

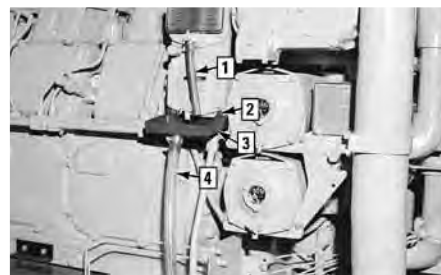
**4C-9451 and 4C-9452 Idler Gear Wrench (Part of 9U-5105 Group)**

Model: 3600 Engines

- Used to remove and install bolts on rear idler gear of 3612 and 3616 Engines (accesses hard to reach bolts)
- Has 3/4 inch square-drive to connect torque wrench
- Torque extensions of 101.6 and 254 mm (4 and 10 in) are etched on each wrench so correct torque can be calculated (refer to SEHS7150 Special Instruction for correct torque wrench setting)
- 2 opposite L-shaped wrenches  
 12-point socket: 1 1/8 inch  
 Square drive end: 3/4 inch

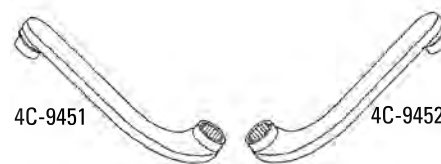
**Reference**

SENR3594, Service Manual Module of SENR3590 Service Manual

Part Number	Description
4C-9451	Idler Rear Wrench
4C-9452	Idler Rear Wrench

**Engine Tools****9U-6461 Phoenix Screwdriver (Part of 9U-5105 Group)**

Model: 3600 Engines  
 Warranty: Manufacturer's

- Used to tighten Phoenix connectors to correct torque (prevents over-torque and thus damage to terminals)
- Length: 180.0 mm (7.0 in)

Part Number	Description
9U-6461	Phoenix Screwdriver



## 8T-0890 Puller Group (Part of 9U-5105 Group)

Model: 3600 Engines

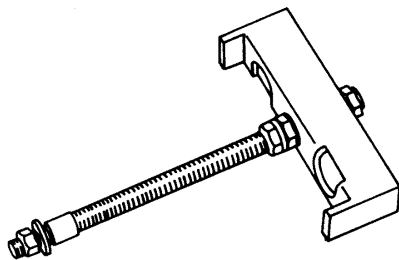

- Used to remove rotor cover from centrifugal oil filter (allows replacement of 7C-8390 Rotor Liner)

### References

SEN3594, Service Manual Module of SENR3590 Service Manual  
 SENR3600, Service Manual Module of SENR3595 Service Manual

Bolt size and length	1/2 - 13 x 10.5 in
Nuts (3)	1/2 - 13 thd
Bridge	35 x 40 x 169 mm (1.4 x 1.6 x 6.7 in)

Part Number	Description
8T-0890	Puller Group

## Cylinder Head

### 8T-0960 Handling Tool Group (Part of 9U-5105 Group)

Model: 3600 Engines

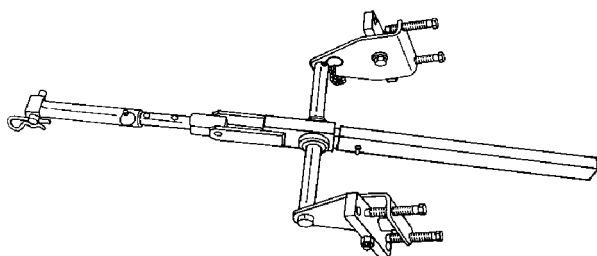

Assembled Handling Tool Group

- Used to raise and lower crankshaft main bearing cap and 207-5034 Stud Tension Tool Group
- 4C-8357 Tray Support Rail is installed in oil pan baffle holes and supports discontinued 8T-0872 Stud Tensioner Tray (tray used as work table to support main bearing caps or stud tensioner tooling before they are lifted into place)
- 8T-0947 Tee Handle is used as handhold to aid in alignment of 207-5034
- Discontinued 8T-0956 Bracket Group is installed into crankcase access cover openings on each side of engine (adjustment screws allow precise leveling of 207-5034); discontinued 8T-0956 includes discontinued 8T-0806 Block, discontinued 8T-0954 Screw, and 8T-7238 Handle
- Two 8T-0916 Pins connect this handling group to main bearing caps (use 4K-0367 Nuts on pins)
- Most parts in the group are assembled with pins and spring clips (clips prevent tooling from falling into oil pan)

### References

SEN3594, Service Manual Module of SENR3590 Service Manual  
 SENR3600, Service Manual Module of SENR3595 Service Manual  
 SENR4259, Service Manual Module of SENR4255 Service Manual



Item	Description
15	No Longer Available

(Continued)



**References (Continued)**

SENR3594, Service Manual Module of SENR3590 Service Manual  
 SENR3600, Service Manual Module of SENR3595 Service Manual  
 SENR4259, Service Manual Module of SENR4255 Service Manual

Item	Part Number	Description
1	8T-0916	Pin
2	8T-0959	Hitch Pin
3	8T-0955	Tensioner Lift Tube Group
4	8T-0948	Lift Lever Group
5	8T-0872	Stud Tensioner Tray
6	8T-0961	Rail Retainer Bushing
7	4C-8357	Tray Support Rail

Item	Part Number	Description
8	4K-0367	Nut - Full
9	8T-0947	Tee Handle
10	1B-4430	Jam Nut
11	8T-0946	Tension Lift Stud
12	8T-0963	Shaft
13	5P-0370	Lock Pin
14 <sup>1</sup>	8T-0956	Bracket Group
--	8T-0960	Handling Tool Group

<sup>1</sup>Includes 8T-0806 Block, 8T-0954 Screw, and 9U-7238 Handle

**126-6918 Head Lifting Bracket (3600 Vee), 126-6919 Head Lifting Bracket (3600 In-line)  
 126-6920 Handle Rod (Part of 9U-5105 Group)**

Model: 3600 Engines  
 Warranty: Six Months

- Replaces discontinued 8T-2860 Head Lifting Bracket (3600)
- Used to remove and install heads on 3600 Engines — 126-6918 used for Vee engines and 126-6920 used for in-line engines
- Lifting bracket for Vee engines is designed with 25° angle (keeps bottom of head parallel to 25° block angle)
- Attach lifting bracket bolt to head with two 5D-1972 Bolts (3/4 in - 10 11 3/4 in) (part of 9U-5105 Group)
- Handle rod screws into either bracket and helps mechanic position head during assembly
- Not shown: 5D-1972 Bolt (3/4 in -10, 11 3/4 in)

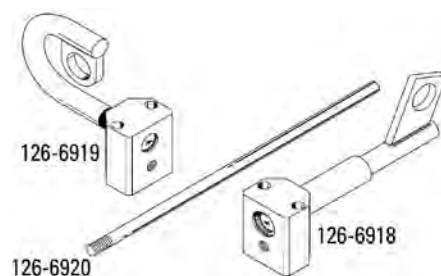

Working load limit for either lifting bracket
227 kg (500 lb)

Part Number	Description
126-6918	Head Lifting Bracket
126-6919	Head Lifting Bracket
126-6920	Handle Rod

**Crankshaft and Camshaft**

**8T-3029 Camshaft Segment Support Group (Part of 9U-5105 Group)**

Model: 3600 Engines

- Used to support camshaft segments during removal and installation (weight of camshaft segments 28 kg [62 lb])
- Swivel assembly is adjustable for easier alignment of segment during installation
- Discontinued 8T-3050 Bracket bolts directly into the bottom 2 bolt holes of camshaft cover on 3606 and 3608 Engines
- 1U-6311 Cam Support Adapter allows the discontinued 8T-3050 to be mounted in bottom 2 holes of camshaft covers on 3612, 3616 and 3618 Engines (use two 3/8-16 bolts to attach 1U-6311 to discontinued 8T-3050)

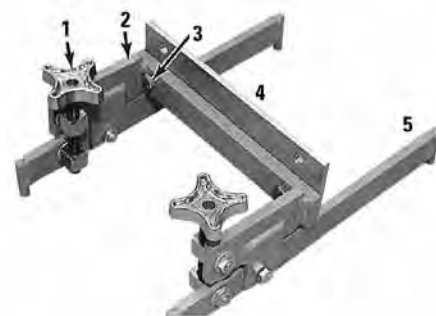

**References**

SENR3594, Service Manual Manual Module of SENR3590 Service Manual  
 SENR3600, Service Manual Module of SENR3595 Service Manual  
 SENR4259, Service Manual Module of SENR4255 Service Manual

(Continued)

## Crankshaft and Camshaft (Continued)

### 8T-3029 Camshaft Segment Support Group (Part of 9U-5105 Group)

Model: 3600 Engines

Item	Description
3	3/8 in - 16 Bolt (not part of 8T-3029)

Item	Part Number	Description
1	8T-3049	Swivel Assembly
2	8T-3050	Bracket
4	1U-6311	Camshaft Support Adapter
5	8T-3048	Lifting Bar
--	8T-3029	Camshaft Segment Support Group

### 9U-5932 Camshaft Torque Extension (Part of 9U-5105 and 9U-5106 Groups)

Model: 3600 Engines



- Used to remove and install bolts retaining thick-flange camshaft segments
- Designed with minimum clearance to fit onto the bolts (conventional sockets cannot reach the bolts)
- Using the extension requires a calculation to determine the correct torque; the extension uses a 100 mm (4 in) lever arm (use Form SEHS7150 to calculate the proper torque wrench setting)

Square drive	1/2 in
Socket (12 point)	15/16 in
Length of extension	100 mm (4.0 in)

Part Number	Description
9U-5932	Extension Camshaft Torque

### 8T-0970 Camshaft Bearing Tool Group, 3600 Engines (Part of 9U-5105 Group)

### 156-7155 Camshaft Bearing Tool Group, 3618 Engines (Not Part of 9U-5105 Group)

Model: 3600 Engines

- Used to remove and install camshaft bearings (not possible by any other means)
- Discontinued 8T-0968 Bridge will pilot in bearing bore on one side and when reversed, pilot in cylinder block bearing bore on other side
- Used with 3S-6224 Hydraulic Pump (115 V) or 8S-8033 Hydraulic Pump (230 V); other required tooling is 8T-3035 Lines Group and 8T-0820 Pressure Gauge

Part Number	Description
8T-0970	Camshaft Bearing Tool Group
156-7155	Camshaft Bearing Tool Group

**References**

SENR3594, Service Manual Module of SENR3590 Service Manual  
 SENR3600, Service Manual Module of SENR3595 Service Manual  
 SENR4259, Service Manual Module of SENR4255 Service Manual

Cylinder	
Capacity	180 kN (20 ton)
Stroke	76 mm (3.0 in)
Maximum operating pressure	69,000 kPa (10,000 psi)

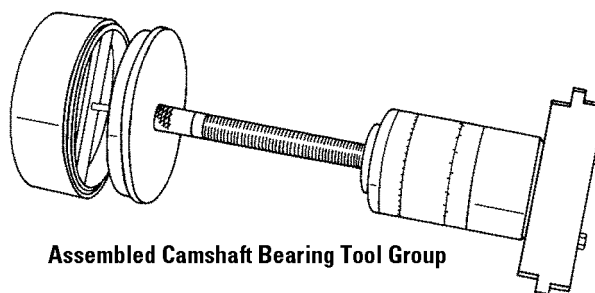

Assembled Camshaft Bearing Tool Group

Engine Tools

**Camshaft Bearing Tools**



Item	Part Number	Description
<b>8T-0970 Camshaft Bearing Tool Group, 3600 Engines</b>		
1 <sup>1</sup>	316-1496	Cylinder
2	8T-0969	Rod
2 <sup>1</sup>	184-5397	Threaded Rod
3	8T-0968	Bridge
4	8T-0972	Pilot
5	8T-0971	Plate
6	0L-1143	Bolt
7 <sup>1</sup>	0S-1619	Bolt
8 <sup>1</sup>	8T-0973	Insert for Cylinder

Item	Part Number	Description
<b>156-7155 Camshaft Bearing Tool Group, 3618 Engines</b>		
1 <sup>1</sup>	316-1496	Cylinder
2 <sup>1</sup>	184-5397	Threaded Rod
3	156-7157	Bridge
4	156-7154	Pilot
5	156-7156	Plate
6	0L-1143	Bolt
7 <sup>1</sup>	0S-1619	Bolt
8 <sup>1</sup>	8T-0973	Insert for Cylinder
9	317-7104	Insert for 316-1496 Cylinder
<b>Not Shown</b>		
9	317-7104	Insert for 316-1496 Cylinder

<sup>1</sup> Common to both groups

## 134-0932 Main Bearing Driver (Part of 9U-5105 Group)

Model: 3600 Engines

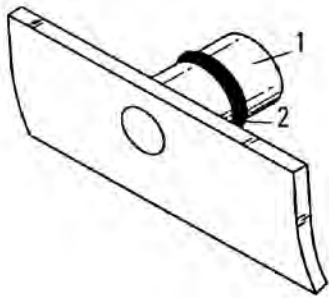

- Used to remove and install crankshaft main bearings (older 6I-4528 Main Bearing and new 111-3378 Main Bearing) without removing crankshaft
- Bearings are easily removed by inserting tool into crankshaft journal lubrication hole and rotating crankshaft clockwise to roll bearing out
- Will also roll in new bearings by rotating crankshaft in a counterclockwise direction
- Threaded hole in pin allows easy removal from oil passage if tool shears (tool is designed to shear to prevent damage to crankshaft)

### References

SENR3594, Module of SENR3590

SENR3600, Module of SENR3595

SENR4259, Module of SENR4245

SENR5535, Module of SENR5500

Blade width	90 mm (3.54 in)
Blade thickness	6.35 mm (0.250 in)
Pin diameter	19.48 mm (0.767 in)
Threaded puller hole in pin 8 -32	

Item	Part Number	Description
1	134-0932	Main Bearing Driver
2	8F-3469	Seal

## Piston and Connecting Rod Assembly

### 145-5190 Piston Support Group, (Part of 9U-5105)

Model: All 3600 Engines



- Used to safely support piston and connecting rod assembly on all 3600 Engines when replacing connecting rod bearing
- Mounted in place of oil cooling jet with two 0S-1619 Bolts (after engine rotated until piston at top dead center position)
- Lightweight aluminum for ease of installation
- Knurled for firm grip
- Not shown: 0S-1619 Bolts, 3/8-16 x 3 inch (2)

### References

SENR3594, Service Manual Module of SENR3590 Service Manual

SENR3600, Service Manual Module of SENR3595 Service Manual

Support capacity	102 kg (225 lb)
------------------	-----------------

Part Number	Description
145-5190	Piston Support Group

## 8T-3022 Rod Guide Group (Part of 9U-5105 Group)

Model: 3606 and 3608 Engines

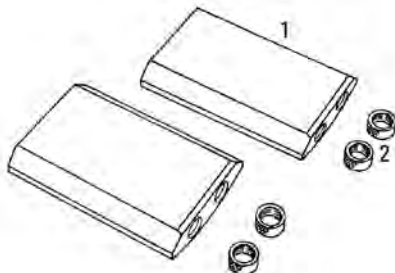

- Used to protect crankshaft bearing journal from damage
- Guides help align connecting rod onto crankshaft during installation (held to connecting rod studs with 8T-2859 Nut)
- Both parts constructed from aluminum to help prevent scratching of finished machined surfaces
- Guide dimensions: 163 x 109 x 32 mm (6.4 x 4.3 x 1.2 in)
- Knurled nut: 3/4 - 16 thread

### References

SENR3600, Service Manual Module of SENR3595 Service Manual

SENR4259, Service Manual Module of SENR4255 Service Manual

(Continued)

**8T-3022 Rod Guide Group (Part of 9U-5105 Group) (Continued)**

Model: 3606 and 3608 Engines

Item	Description
1	Guide (not serviced separately)

Item	Part Number	Description
--	8T-3022	Rod Guide Group
<b>Rod Guide Group Consists of:</b>		
2	8T-2859	Nut

**4C-6357 Guide Group (Part of 9U-5105 Group)**

Model: 3612 and 3616 Engines

- Used to protect crankshaft bearing journal from damage
- Guides help align connecting rod onto crankshaft during installation (held to connecting rod studs with 8T-2859 Nut)
- Both parts constructed from aluminum to help prevent scratching of finished machined surfaces
- Guide dimensions: 163 x 96.5 x 30.5 mm (6.4 x 3.8 x 1.2 in)
- Knurled nut: 3/4 - 16 thread

**Reference**

SENR3594, Service Manual Module of SENR3590 Service Manual

Item	Description
1	Guide (not serviced separately)

Item	Part Number	Description
--	4C-6357	Guide Group
<b>Guide Group Consists of:</b>		
2	8T-2859	Nut

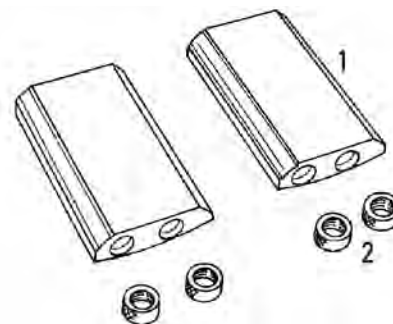
**1U-8692 Guide, Piston Pin (Part of 9U-5105 Group)**

Model: 3600 Engines

- Used to easily install piston pin into piston and rod assembly (pin is put onto guide which helps align piston and rod bores)
- Constructed of lightweight aluminum

**References**

SENR3594, Service Manual Module of SENR3590 Service Manual

SENR3600, Service Manual Module of SENR3595 Service Manual

SENR4259, Service Manual Module of SENR4255 Service Manual

Part Number	Description	Diameter	Length	Weight
1U-8692	Piston Pin Guide	22.8 cm (9.0 in)	64.2 cm (25.3 in)	7 kg (14 lb)

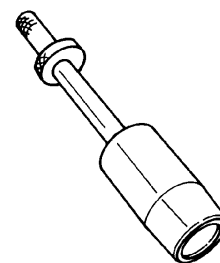

## 136-1452 Internal Pliers Assembly (Part of 9U-5105 Group)

Model: 3600 Engines

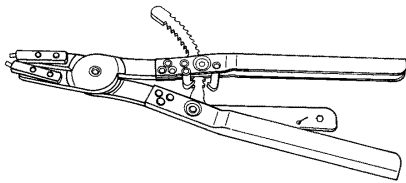

- Used to remove and install piston pin retainer or snap ring (pliers have locking handles for easier installation)
- Use with 9U-5981 Snap Ring Retainer to provide added protection if snap ring slips off pliers
- Replaceable tip makes pliers more economical
- Service Part: 1U-6728 Tip Set

### References

SEN3594, Service Manual Module of SENR3590 Service Manual  
 SENR3600, Service Manual Module of SENR3595 Service Manual  
 SENR4259, Service Manual Module of SENR4255 Service Manual

Part Number	Description	Length
136-1452	Internal Pliers Assembly	40 cm (16 in)

## 9U-5981 Snap Ring Retainer (Part of 9U-5105 Group)

Model: 3600 Engines

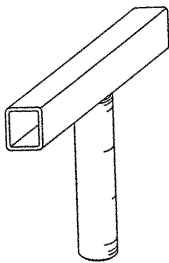

- Used to contain piston pin retainer (snap ring)
- Used with 136-1452 Internal Pliers Assembly during disassembly and assembly of piston and connecting rod

### References

SEN3594, Service Manual Module of SENR3590 Service Manual  
 SENR3600, Service Manual Module of SENR3595 Service Manual  
 SENR4259, Service Manual Module of SENR4255 Service Manual

Handle	31.8 mm (1.25 in) square tubing
Body diameter	42.9 mm (1.68 in)
Body length	20 x 20 cm (7.8 x 7.8 in)

Part Number	Description
9U-5981	Snap Ring Retainer

## Block

### 235-0632 Cylinder Installation Tool Group (Part of 9U-5105 Group)

Model: 3600 Engines

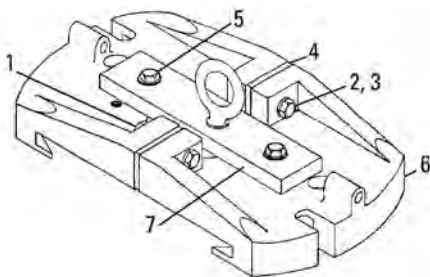

- Replaces discontinued 4C-9041 Cylinder Installation Tool Group
- Used to remove and install cylinder assembly, cylinder liner, and piston and connecting rod assembly (provides convenient method of attaching a hoist)
- Piston and connecting rod assembly can be removed separately using 235-0612 Bracket, 9S-1366 Bolt, and 5P-1076 Washer

### References

SEN3594, Service Manual Module of SENR3590 Service Manual  
 SENR3600, Service Manual Module of SENR3595 Service Manual  
 SENR4259, Service Manual Module of SENR4255 Service Manual

Item	Part Number	Description	Quantity
--	235-0632	Cylinder Installation Tool Group	--
<b>Cylinder Installation Tool Group Consists of:</b>			
1	1F-7958	Full Nut (1/2 - 13) (fork mounting hardware)	2
2	9S-1366	Bolt (1/2-13)	2
3	5P-1076	Hard Washer, 13.5 mm ID x 30 mm OD	6
4	1U-7619	Spacer	2

(Continued)

**235-0632 Cylinder Installation Tool Group (Part of 9U-5105 Group) (Continued)**

Model: 3600 Engines

Item	Part Number	Description	Quantity
<b>Cylinder Installation Tool Group Consists of: (Continued)</b>			
5	0V-0375	Bolt	2
6	4C-9040	Bracket	2
7	235-0612	Bracket Assembly	1

**4C-9818 Shank-Hex (Part of 9U-5105 Group)****4C-9819 Universal Joint (Part of 9U-5105 Group)**

Model: 3600 Engines

- Used to easily rotate crankshaft
- Used with 213-3110 Socket, or similar part, and 12.7 mm (1/2 in) drill (reversible variable speed drill works best, but is not necessary)

<b>4C-9818 Hex Shank</b>	
Shank size	7/16 hex
Shank length	32 mm (1.3 in)
Drive end	1/2 in square drive with lock button
Overall length	70 mm (2.8 in)
<b>4C-9819 Universal Joint</b>	
Outside diameter	30 mm (1.9 in)
Overall length	63 mm (2.5 in)
Male drive end	1/2 in square drive with lock button
Female drive end	1/2 in square drive



Item	Part Number	Description
1	213-3110	Socket, 1 1/8 in
2	4C-9819	Universal Joint
3	4C-9818	Hex Shank

**191-1135 Cylinder Liner Spacer Assembly (Part of 9U-5105 Group)**

Model: 3600 Engines

- Used to install cylinder liner into block (using two will easily and evenly seat the liners)
- Steel tube designed to fit over head studs
- Used with 2 head-stud nuts, 4C-6987 Socket (184-3131 Socket for 3618 Engines) and 239-6826 Ratchet (1/2 inch Drive)
- Length: 31.432 cm (12.375 in)
- 2 required



Part Number	Description
191-1135	Cylinder Space Assembly

## Vibration Damper and Flywheel 4C-9426 Damper Guide Pin (Part of 9U-5105 Group)

Model: 3600 Engines

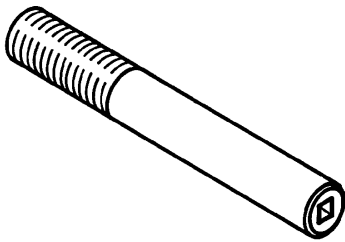

- Used to align and support vibration damper during assembly and disassembly of 3606, 3608, and 3612 Engines (2 required)
- 1/2 inch square drive socket for easy installation and removal

### References

SEN3594, Service Manual Module of SENR3590 Service Manual  
SEN3600, Service Manual Module of SENR3595 Service Manual  
SEN4259, Service Manual Module of SENR4255 Service Manual

Part No.	Description	Diameter	Length	Thread	Weight
4C-9426	Damper Guide Pin	25 mm (1 in)	15.2 cm (6.0 in)	1 - 14 thd	0.6 kg (1.3 lb)

## 1U-9393 Damper Guide Pin (Part of 9U-5105 Group)

Model: 3600 Engines

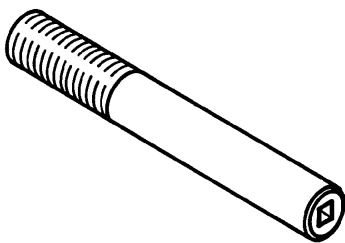

- Used to align and support single vibration dampers (2 required)
- 1/2 inch square drive socket for easy installation and removal

### References

SEN3594, Service Manual Module of SENR3590 Service Manual  
SEN3600, Service Manual Module of SENR3595 Service Manual  
SEN4259, Service Manual Module of SENR4255 Service Manual

Part No.	Description	Diameter	Length	Thread	Weight
1U-9393	Damper Guide Pin	25 mm (1 in)	15.2 cm (6.0 in)	1 - 8 thd	0.6 kg (1.3 lb)

## 1U-9392 Damper Guide Pin (Part of 9U-5105 Group)

Model: 3600 Engines

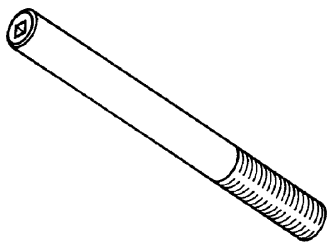

- Used to align and support outer vibration damper of dual vibration dampers (2 required)
- 1/2 inch square drive socket for easy installation and removal

### References

SEN3594, Service Manual Module of SENR3590 Service Manual  
SEN3600, Service Manual Module of SENR3595 Service Manual  
SEN4259, Service Manual Module of SENR4255 Service Manual

Part No.	Description	Diameter	Length	Thread	Weight
1U-9392	Damper Guide Pin	28.4 mm (1.12 in)	25.4 cm (10.0 in)	1 1/8 - 8 thd	1.3 kg (2.9 lb)

## 8T-0914 Flywheel Guide Pin (Part of 9U-5105 Group)

Model: 3600 Engines

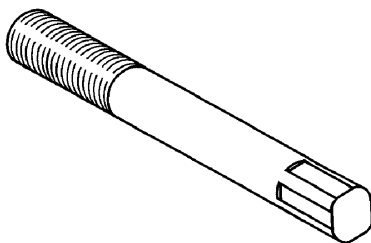

- Used to align and support flywheel and rear gear support assembly during installation and removal (2 required)
- 1/2 inch external square drive for easy installation and removal

### References

SEN3594, Service Manual Module of SENR3590 Service Manual  
SEN3600, Service Manual Module of SENR3595 Service Manual  
SEN4259, Service Manual Module of SENR4255 Service Manual

Part No.	Description	Diameter	Length	Thread	Weight
8T-0914	Flywheel Guide Pin	28.4 mm (1.12 in)	61 cm (24 in)	1 1/8 - 12 thd	3 kg (6 lb)



### 9U-5106 Diesel Tool Group

Model: 3600 Diesel Engines

Warranty: Six Months

Part Number	Description
9U-5106	Diesel Tool Group
<b>9U-5106 Consists of:</b>	
130-6993	Injector Bore Brush
1U-8795	Governor Torque Arm
4C-5719	Piston Ring Compression Group
4C-6594	Timing Tool Group

Part Number	Description
<b>9U-5106 Consists of: (Continued)</b>	
5P-0328	Crowfoot Wrench, 7/8 in (Fuel Line)
5P-0329	Crowfoot Wrench, 15/16 in (Fuel Line)
6V-7073	Liner Puller Group
8T-3268	Bolt (2)
9U-5932	Extension Camshaft Torque

### 6V-7073 Liner Puller Group (Part of 9U-5106 Group)

Model: 3600 Diesel Engines

- Used to remove and install cylinder liner using hydraulic pressure (hoist attaches to puller to easily handle tool and cylinder liner)
- Hydraulic pump connects to two hydraulic puller assemblies for a combined pulling force of 11 tons at 5000 psi
- Used with 3S-6224 Hydraulic Pump (115 Volt) or 8S-8033 Hydraulic Pump (230 Volt); other required tooling is 8T-3035 Lines Group and 8T-0820 Pressure Gauge

#### References

SENR3594, Service Manual Module of SENR3590 Service Manual

SENR3600, Service Manual Module of SENR3595 Service Manual

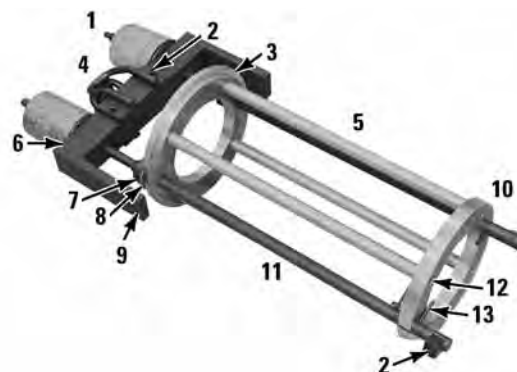

Item	Part Number	Description
--	6V-7073	Liner Puller Group
<b>6V-7073 Liner Puller Group Consists of:</b>		
3.0	6V-7074	Top Ring
4.0	8T-2835	Bracket
6.0	6V-7079	Bridge
7.0	8T-2836	Nut
10.0	6V-7075	Bottom Ring
11.0	299-5231	Leg Assembly
2.0	2J-5245	Bolt - Hex Socket Head
1.0	316-1493	Hydraulic Puller Group

Item	Part Number	Description
<b>6V-7073 Liner Puller Group Consists of: (Continued)</b>		
8.0	4B-5278	Washer
12.0	4D-3120	Bolt
13.0	4H-6996	Spring Pin
5.0	6V-7069	Rod Spacer
9.0	6V-7078	Support Bridge
<b>Not shown</b>		
--	1B-4331	Nut
--	4B-5276	Bolt Washer
--	2K-6073	Bolt

## 8T-3268 Bolt (Part of 9U-5106 Group)

Model: 3600 Engines

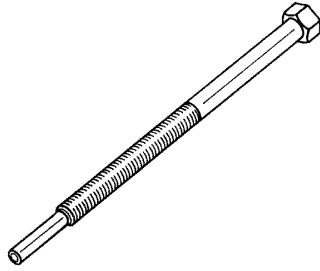

- Used to remove unit injector by evenly tightening two bolts at the same time

### References

SENR3594, Service Manual Module of SENR3590 Service Manual

SENR3600, Service Manual Module of SENR3595 Service Manual

Part No.	Description	Overall Length	Pilot Diameter	Pilot Length	Thread
8T-3268	Bolt	13.9 cm (5.5 in)	6 mm (0.24 in)	27 mm (1.1 in)	15/16 - 18

## 4C-6594 Timing and Fuel Setting Tool Group (Part of 9U-5106 Group)

Model: 3600 Diesel Engines

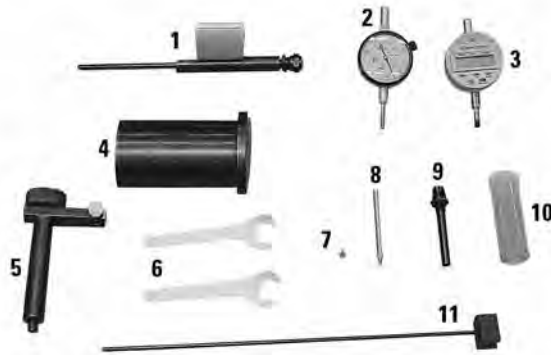

- Replaces discontinued 6V-6170 Timing and Fuel Setting Tool Group
- Used to accurately test and adjust injector synchronization and fuel timing dimension
- 4C-6593 Valve Lash Tool is used to check and adjust valve lash clearance of intake and exhaust valves using a dial indicator (used with 6V-3075 Dial Indicator and 8S-3675 Contact Point)
- 6V-3075 Dial Indicator has black numbers and markings for positive travel and red markings for negative travel (369-2607 is an optional digital indicator)

### References

- SENR3593, Service Manual Module of SENR3590 Service Manual
- SENR3599, Service Manual Module of SENR3595 Service Manual
- SEHS9599, Special Instruction

Item	Part Number	Description
<b>4C-6594 Timing and Fuel Setting Tool Group Consists of:</b>		
1	6V-9058	Fixture Assembly
2	6V-3075	Indicator - Dial
3	369-2607	Digital Indicator
4	6V-9056	Set Gauge
5 <sup>1</sup>	4C-6593	Adjusting As - Valve Lash
6	6V-7918	Wrench
7	8S-3675	Point - Indicator
8	5P-7263	Indicator Contact Point

Item	Part Number	Description
<b>4C-6594 Timing and Fuel Setting Tool Group Consists of: (Continued)</b>		
9 <sup>1</sup>	4C-8753	Extended Collet
10	5P-7276	Container
11	6V-9057	Rack Synchronizing Gauge
--	4C-6594	Timing Tool Group
<b>Not shown<sup>2</sup></b>		
--	6V-7145	Case
--	4C-6596	Bottom Insert <sup>1</sup>
--	4C-6595	Top Insert <sup>1</sup>

<sup>1</sup>Parts used to upgrade a discontinued 6V-6170 to a 4C-6594 (also order an NEEG2491 Decal)

<sup>2</sup>Parts used to upgrade a discontinued 6V-6170 to a 4C-6594 (also order an NEEG2491 Decal)

**1U-8795 Governor Torque Arm (Part of 9U-5106 Group)**

Model: 3600 Engines

- Holds governor or actuator terminal shaft to fuel "ON" position while injectors are being adjusted
- When torque arm is installed with weight in horizontal position, 18.6 N·m (13.65 ft-lb) is applied to governor linkage
- Shaft clearance hole diameter: 16.3 mm (0.64 in)

**References**

SENR3594, Service Manual Module of SENR3590 Service Manual

SENR3600, Service Manual Module of SENR3595 Service Manual

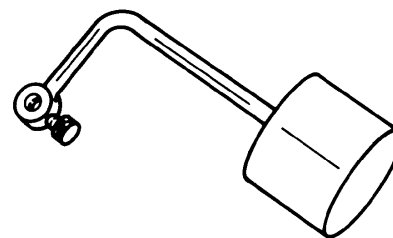

Part Number	Description
1U-8795	Governor Torque Arm

**9U-5932 Camshaft Torque Extension (Part of 9U-5105 and 9U-5106 Groups)**

Model: 3600 Engines

- Used to remove and install bolts retaining thick-flange camshaft segments
- Designed with minimum clearance to fit onto the bolts (conventional sockets cannot reach the bolts)
- Using the extension requires a calculation to determine the correct torque; the extension uses a 100 mm (4 in) lever arm (use Form SEHS7150 to calculate the proper torque wrench setting)

Square drive	1/2 in
Socket (12 point)	15/16 in
Length of extension	100 mm (4.0 in)



Part Number	Description
9U-5932	Extension Camshaft Torque

**191-1135 Cylinder Liner Spacer Assembly****Essential Tool**

Model: All 3600 and G3600 Engines

Warranty: Six Months

- Used to install cylinder liner into cylinder head
- Used with 4C-6987 Socket and two cylinder head stud nuts
- Used with 184-3131 Socket for 3618 Engines
- Steel tube fits over cylinder head studs
- Using two spacer assemblies will easily and evenly seat cylinder liners
- Overall length: 314.32 mm (12.375 in)

Part Number	Description
191-1135	Cylinder Space Assembly

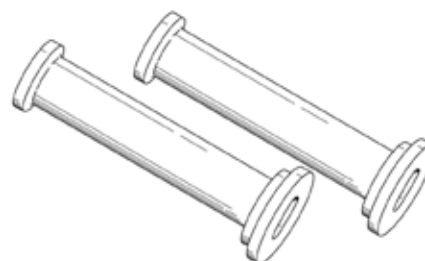
**146-2726 Maintenance Tool Group**

Model: G3600 Engines

Warranty: Six Months

- Used to perform routine maintenance tasks on G3600 Engines

Item (Not shown)	Description
NETG5044	Software License Card (required to activate software)

(Continued)

## 146-2726 Maintenance Tool Group (Continued)

Model: G3600 Engines

Warranty: Six Months

Engine Tools

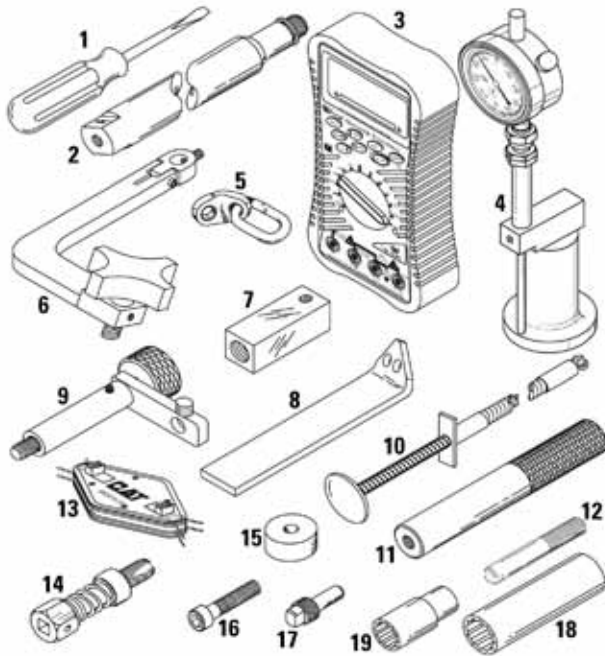

Item	Part Number	Description	Use
1	6V-9124	Screwdriver	Used for terminal strips
2	146-2739	Cylinder Pressure Adapter	Connects outside air pressure source to cylinders on 3500 and 3600 Engines during cylinder leak down testing
3	257-9140	Fluke 87V Multimeter	Test and adjust electrical circuits
4	148-2997	Valve Recession Tool Kit	Measures valve seat recession by placing magnetic block on top of valve rotator with rod extending to top of cylinder head (used with 6V-3075 Dial Indicator or 369-2607 Digital Indicator)
5	138-7573	Bracket Assembly - Link	Turbo lift bracket
6	146-2742	GAV Lash Tool	Set gas admission valve (GAV) lash by installing in valve cover base rear bolt hole and adjusting 5P-2056 Indicator Tip on gas admission rocker arm flat (use with 147-5536 Indicator Contact Point and 6V-3075 Indicator on gas admission rocker arms with pin)
7	143-8995	Leak Down Check Tool	Tests check valves in prechamber
8	9U-6244	Support	Turbo support
9	4C-6593	Adjusting As - Valve Lash	Check and adjust valve lash
10	146-2728	Flex Pickup Tool	Remove check valve seal
11	1P-0529	Handle	Waste gate tool
12	9U-6248	Guide Bolt	Install equally spaced bolts in outer ring of holes in back of turbocharger compressor housing during assembly
13	9U-7516	Spark Plug Gauge	Check spark plug gap
14	9U-7511	Spark Plug Seat Cleaner	Spark plug seat cleaner
15	1P-0462	Plate, 0.937 in Diameter	Waste gate tool

(Continued)

**146-2726 Maintenance Tool Group (Continued)**

Model: G3600 Engines

Warranty: Six Months

Item	Part Number	Description	Use
16	6L-5897	Bolt, 7/8 in long	Waste gate tool
17	143-8997	Dummy Check Valve	Checks leak down fixture (143-8995) before testing check valves
18	4C-4601	Spark Plug Socket	Remove and install spark plugs
19	9S-5031 <sup>1</sup>	Deep Well Socket	Removes combustion sensor spark plug
--	146-2726	Maintenance Tool Group	--
<b>Not shown</b>			
--	285-0901	Blowby Pickup Group	Check blow by volume
--	368-9910	Multi-tool Group	Measures volume of blowby gas coming from crankcase breather and air velocity through radiator

<sup>1</sup> Comes with insert for removing spark plugs**143-8995 Leak Down Check Tool****143-8997 Check Valve (Dummy)**

Model: G3606, G3608, G3612, and G3616 Engines

Warranty: Six Months

- Used to test prechamber check valves for leakage
- When 827 kPa (120 psi) air pressure is applied, pressure cannot leak down below 689 kPa (100 psi) within five seconds
- Used with external compressed air supply, air pressure gauge with a maximum 1378 kPa (200 psi) capacity, and quick action shut-off valve
- 143-8997 Dummy Check Valve is used to verify that leak down check tool does not have any leaks
- A 2M-4453 O-ring Seal is included with leak down check tool and is a service part
- When connecting air supply, it must be as close as possible [within 300.0 mm (12.0 in) max] to inlet side of air pressure gauge
- Maximum air pressure (pressure gauge): 1378 kPa (200 psi)
- Maximum length between tool and leak down check valve: 304.0 mm (12.0 in)

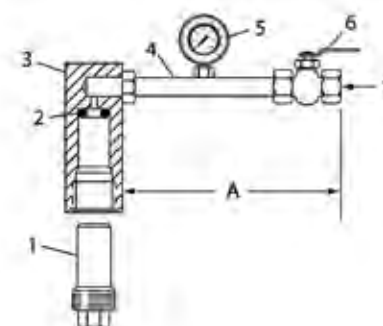

Item	Description
4	Tube
5	Pressure gauge
6	Ball valve
7	Air supply
A	305 mm (12.0 in) maximum length

Item	Part Number	Description
1	143-8997	Dummy Check Valve
2	2M-4453	O-ring Seal
3	143-8995	Leak Down Check Tool

## 4C-6583 Governor Calibration Tool

Model: 3600 Locomotive Engine with PGEV Governor

Warranty: Six Months

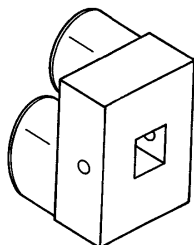

- Holds the governor shaft to the fuel on position when synchronizing injectors
- Makes it easier to rotate governor terminal shaft and easier to hold it in position when adjusting power setting
- Has 2 dowels on one side to fit into 2 holes on governor shaft position indicator
- 1/2 inch square drive connection on other side for attaching socket wrench as lever arm

Part Number	Description
4C-6583	Governor Calibration Tool

## 9U-5102 Main Bearing Journal Cover Assembly

Model: 3600 Engines

Warranty: Six Months



- Used to protect crankshaft bearing journals from impact damage during removal, installation, and transportation
- Made from oil resistant rubber
- Spring and hook latching device makes attaching simple and easy
- Overall size (L x W): 830.0 x 120.0 mm (32.0 x 4.7 in)

Part Number	Description
9U-5102	Main Bearing Journal Cover Assembly

## 147-2285 Diesel Valve Seat Group

Model: 3600 Diesel Engines

Warranty: Six Months

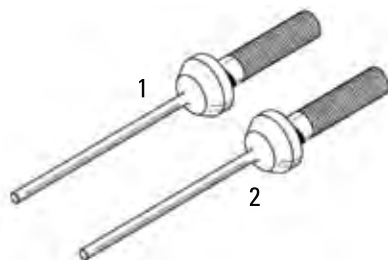

- Used to measure valve seat angle after machining of seat
- Pilots in valve guide to ensure that seat is perpendicular to guide
- Features knurled handle for positive grip
- Lightly oiling tool before storage is recommended to prevent corrosion of precision machined surfaces
- Tool group includes case and foam insert

### References

SEBF8129, Guideline for Reusable Parts

SEHS0095, Special Instruction

Item	Part No.	Description	Seat Angle	Overall Length	Pilot Diameter
1	147-1642	Valve Seat Angle Gauge	30.5°	344.50 mm (13.56 in)	16 mm (0.630 in)
2	147-1643	Valve Seat Angle Gauge	31°	344.50 mm (13.56 in)	16 mm (0.630 in)
--	147-2285	Diesel Valve Seat Group	--	--	--

(Continued)

**147-2285 Diesel Valve Seat Group (Continued)**

Model: 3600 Diesel Engines

Warranty: Six Months

Item	Part No.	Description	Seat Angle	Overall Length	Pilot Diameter
Not Shown					
—	6V-3072	Case - Plastic, NEEG2574 Group Decal on lid (9U-7402 Group)	--	--	--

**207-5034 Stud Tensioner Tool Group**

Model: 3600 Engines

Warranty: Six Months

- Used to tension cylinder head studs and main bearing studs
- Used with 8T-0820 Pressure Group and 8T-3035 Lines Group
- Used with one of these pumps: 3S-6224 Hydraulic Pump (115V) or 8S-8033 Hydraulic Pump (230V); 8T-0820 Pressure Gauge and 8T-3035 Lines Group also required (Cannot be used with 156-7166, 227-6724, 227-8834, 191-5347, and 156-7167 Hydraulic Pumps which are used with the other stud tensioning tools)
- Used with 8T-0960 Handling Tool Group to remove and install main bearings
- Simultaneously tension four cylinder head studs or two crankshaft main bearing studs (use 8T-0960 Handling Tool Group when removing crankshaft main bearings)
- 4C-5816 Retainer Collar attaches as protective device to 8T-0895 Cylinder Group before tightening or loosening crankshaft main bearing studs (helps contain 207-4607 Collar and stud in case of breakage)
- 8T-0493 Cylinder Test Stud, 8T-0495 Test Stud Spacer, and two 207-4607 Thread Collars are used to test 8T-0895 Cylinder Group
- 9U-5141 Nut Turning Handle used to loosen and tighten nuts while studs are extended (9U-5141 Nut Turning Handle replaces discontinued 4C-6986 Nut Turning Handle)
- 4C-6987 Socket used to pre-torque cylinder head nuts

**References**

SENR3594, Service Manual Module of SENR3590 Service Manual

SENR3600, Service Manual Module of SENR3595 Service Manual

SENR4259, Service Manual Module of SENR4255 Service Manual

SEHS9342, Special Instruction

8T-0895 Cylinder Group	
Applied force of each cylinder at maximum pressure	1540 N @ 69 000 kPa (173 ton @ 10,000 psi)
Piston area	223 cm <sup>2</sup> (34.6 sq in)
Weight	20 kg (45.0 lb)



(Continued)

## 207-5034 Stud Tensioner Tool Group (Continued)

Model: 3600 Engines

Warranty: Six Months

Engine Tools

Item	Part Number	Description
--	207-5034	Stud Tensioner Tool Group
1	207-4607	Threaded Collar (bearing stud)
2	8T-0889	Threaded Collar (head stud)
3	8T-0898	Cylinder Head Pedestal
4	8T-0891	Threaded Collar (head stud)
5	8T-0896	Bearing Pedestal
6	8T-0494	Test Stud Spacer
7	8T-0493	Cylinder Test Stud
8	8T-0897	Cylinder Head Pedestal
9	4C-6987	Socket
10	9U-5141	Nut Turning Handle
11	1B-0581	Bolt
12	4C-5816	Collar Retainer
13	0L-1351	Bolt
14	8T-0895	Cylinder Group
<b>Not shown</b>		
--	8T-0911	Cap
--	8T-0913	Piston
--	8T-0912	Body
--	8T-0901	Valve
--	8T-0902	Screw
--	8T-0903	Screen
--	8T-0904	Ring
--	8T-0907	Spring
--	8T-0908	Bolt
--	8T-0909	Wiper
--	8T-0915	Ring
--	8T-0917	Ring

## 8T-0820 Pressure Gauge

Model: 3600 Engines



- Used to provide pressure reading of hydraulic pumps when used with 207-5034 Stud Tensioner Group or 8T-0970 Cam Bearing Tool Group or 6V-7073 Liner Puller Group or 4C-8568 Liner Puller Group
- Used with 3S-6224 Hydraulic Pump (115 Volt) or 8S-8033 Hydraulic Pump (230 Volt); 2N-1931 Fitting, 45° Street Ell can be used to make gauge face more visible
- Liquid-filled gauge has face calibrated with both kPa and psi

### References

SENR3594, Service Manual Module of SENR3590 Service Manual

SENR3600, Service Manual Module of SENR3595 Service Manual

SENR4259, Service Manual Module of SENR4255 Service Manual

Pressure range	0 - 70,000 kPa (0 - 10,000 psi)
Operating temperature	-20° to 65° C (-4° to 150° F)
Male-threaded connection	1/4 - 18 NPTF
Gauge diameter	102 mm (4.0 in)

(Continued)



**8T-0820 Pressure Gauge (Continued)**

Model: 3600 Engines

Part Number	Description
8T-0820	Standard Pressure Gauge

**8T-3035 Lines Group**

Model: 3600 Engines

- Used to connect hydraulically operated tool to hydraulic pump — 3S-6224 Hydraulic Pump (115V) or 8S-8033 Hydraulic Pump (230V); used in the following applications: remove and install cylinder head and crankshaft main bearings, camshaft bearings, and cylinder liners
- Used with 207-5034 Stud Tensioner Tool Group, 6V-7073 Liner Puller Group, 8T-0970 Camshaft Bearing Tool Group, 6V-7073 Liner Puller Group or 4C-8568 Liner Puller Group

**References**

SENR3594, Service Manual Module of SENR3590 Service Manual

SENR3600, Service Manual Module of SENR3595 Service Manual

SENR4259, Service Manual Module of SENR4255 Service Manual

6D-7726 Hose Assembly	
Length	3480 mm (137.0 in)
Maximum pressure rating	70,000 kPa (10,000 psi)
Threaded connections (both ends)	1/4 - 18 NPTF
1P-2375 Coupler Assembly (male)	
Threaded connection	3/8 - 18 NPTF
Proof pressure	82,000 kPa (12,000 psi)
Burst pressure	137,000 kPa (20,000 psi)
1P-2376 Coupler Assembly (female)	
Threaded connection	1/4 - 18 NPTF
Proof pressure	82,000 kPa (12,000 psi)
Burst pressure	144,000 kPa (21,000 psi)
8T-5206 Manifold	
Number of ports	6
Threaded connection (female)	3/8 - 16 NPTF
Plug ( 3/8-18 NPTF)	3J-5390 Plug



(Continued)

## 8T-3035 Lines Group (Continued)

Model: 3600 Engines

Engine Tools

Item	Part Number	Description
--	8T-3035	Lines Group
1	6D-7726	Hydraulic Hose (2)
2	3J-5390	Plug - NPTF (Ext Hex) 3/8 in-18 NPTF external to 1/8 in-27 NPTF internal
3	8T-5206	Manifold
4	1P-2375	Coupler Assembly Quick Connective (Male)
5	1P-2376	Coupler Assembly Quick Connective (Female) (2)

## 156-7159 Camshaft Separation Assembly

Model: 3618 Engines (serial numbers 2MW1-UP)

Warranty: Six Months



- Used to separate camshaft segments
- Replaces separating method which used jacking screws (these holes are no longer available in current camshafts)
- Used with 9X-8881 Bolt
- Bolt length: 57.2 mm (2.25 in)
- Bolt size: 5/8 - 11

Part Number	Description
156-7159	Camshaft Separation Assembly

### Reference

REN1333-01, Service Manual

## 156-7160 Piston Support

Model: 3618 Engines

Warranty: Six Months

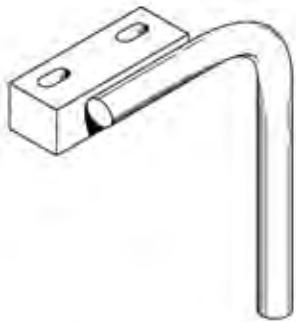

- Used to safely support piston and connecting rod assembly while replacing connecting rod bearings
- Made of lightweight aluminum for easy installation
- Mounts in place of cooling jet with existing bolts

Part Number	Description
156-7160	Piston Support

**178-5063 Rod Cap Guide (3618)**

Model: 3618 Engines (2MW1-Up)

Warranty: Six Months

Part Number	Description
178-5063	Rod Cap Guide

- Used to easily remove and install connecting rod cap
- Guides (2) thread into lower portion of connecting rod
- Helps prevent damage to connecting rod cap
- Thread: M24 x 3.0

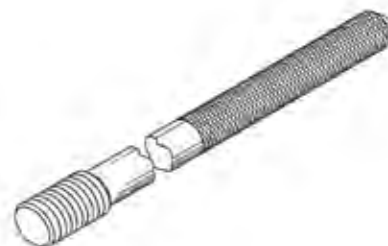
**145-0316 Cleaning Kit**

Model: 3600 Gas Engines with Two-Stage After Coolers

Warranty: Six Months

- Used to clean water tubes in 2-stage after coolers
- Soft deposits left by coolant are removed by inserting brushes into after cooler tubes and working back and forth through the length of coolant tubes
- Kit includes 9.5 mm (0.38 in) diameter brushes, rods, handle, and connector
- Rotate cleaning rods and brushes in clockwise direction to prevent parts from unscrewing

Item	Description	Quantity
1	Handle	1
2	Rod	3
3	Brush	12
4	Connector	2

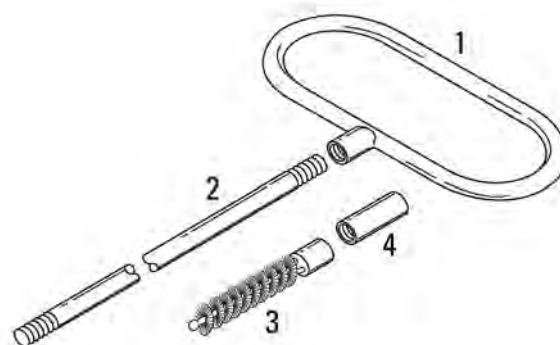

Part Number	Description
145-0316	Cleaning Kit

**187-6273 Prechamber Machining Tool Group (G3600)**

Model: All G3600 Engines

Warranty: Six Months

- Used to remove pitting and corrosion in lower sealing surface of prechambers
- Machines lower sealing surface of prechamber
- Maximum material removal: 0.5 mm (0.02 in)

**Reference**

NEHS0790, Using the 187-6273 Prechamber Machining Tool Group (G3600)

NOTICE
Use with caution and as a last resort to salvage cylinder heads. Excessive material removal could result in loss of core credit of the cylinder head. Follow step-by-step directions in NEHS0790 Tool Operating Manual provided with this tool.

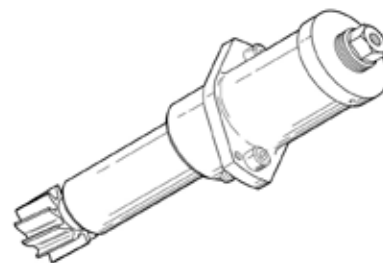

Part Number	Description
187-6273	Prechamber Machining Tool Group

## 151-8689 Template Seal

Model: 3600 and G3600 Engines

Warranty: Six Months

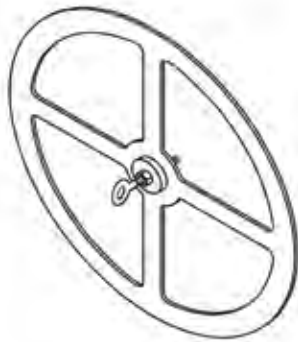

- Just outline ID and OD of template to reveal sealing surface
- Used to easily and quickly identify area of cylinder head that needs a smooth sealing surface
- Any nicks, gouges, and/or damage in this area may result in incorrect sealing

Part Number	Description
151-8689	Template Seal

## 9U-7522 Head Repair Tool Group

Model: All 3600 and G3600 Engines

Warranty: Six Months

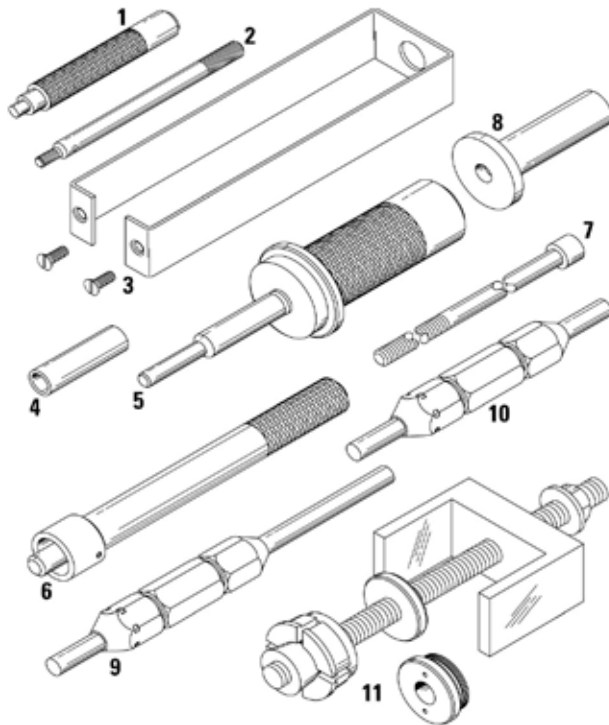

- Used for general disassembly and assembly of cylinder head

### References

3600 and G3600 Engine Service Manuals Cylinder Head Disassembly and Assembly Module

Item	Part Number	Description
1	4C-8540	Dowel and Plug Driver
2	4C-8731	Dowel Pulling Rod
3	4C-9839	Safety Retainer Group
4	8T-2673	Stop Sleeve
5	8T-2674	Valve Seat Driver
6 <sup>1</sup>	8T-2676	Valve Guide Driver Assembly

Item	Part Number	Description
7	8T-2679	Pulling Rod Assembly
8	8T-2781	Cylinder Support Pedestal
9	9U-6399	Valve Guide Gauge
10	9U-6401	Valve Guide Gauge
11	130-1449	Valve Seat Puller Group
12	8T-2660	Compressor Group

(Continued)

### 9U-7522 Head Repair Tool Group (Continued)

Model: All 3600 and G3600 Engines

Warranty: Six Months

Item	Part Number	Description
--	9U-7522	Head Repair Tool Group

<sup>1</sup>Includes discontinued 8T-2677 Driver and discontinued 8T-2678 Sleeve

### Compressor Group (Item 12)

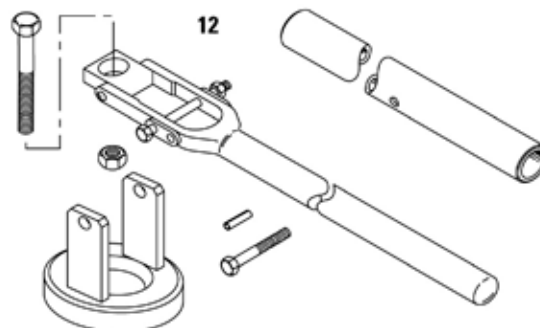

### 148-9704 Seal Installer Group

Model: 3600 Diesel and Heavy Fuel Oil Engines

Warranty: Six Months

- Used to install seals on high pressure aftercoolers (HPAC)
- Group contains seal compressors and pliers to consecutively install both seals — makes installation easier and faster, while helping to eliminate seal damage during installation

Item	Part Number	Description
1	148-6442	Ring
2	148-6443	Ring Insert
3	148-6444	Seal Driver
4	148-6445	Seal Installer

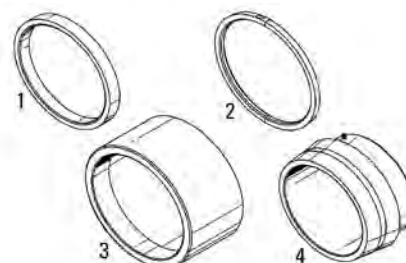

### 148-9704 Seal Installer Group (Continued)

Item	Part Number	Description	Qty.
--	148-9704	Seal Installer Group	--
1	148-9705	Seal Ring Compressor	2
2	148-9707	Ring Compressor Pliers	2

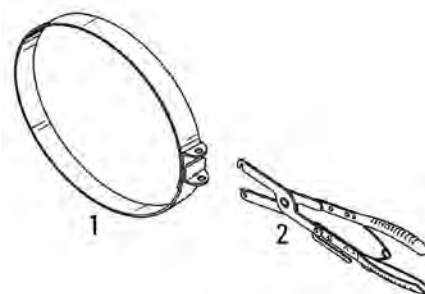

## 9U-6249 Cylinder Tool Group

## 9U-6250 Pump Tool Group

Model: 3600 Engines

Warranty: Six Months



- Both tool groups used together to disassemble and assemble 3600 Engine turbochargers
- Used with 6V-7030 Micrometer Depth Gauge Group (metric) or 6V-2012 Micrometer Depth Gauge Group (inches), and 8T-5096 Dial Indicator Group
- Hoses and fittings working pressure: 10,000 psi (68,900 kPa)

### Reference

NEHS0615, Tool Operating Manual, 3600 Turbocharger Disassembly and Assembly

9U-6249 Group Includes (not shown)	
Media Number	Description
NEEG2543	Decal
9U-6250 Group Includes (not shown)	
Media Number	Description
NEEG2544	Decal

Item	Part Number	Description	Qty.
<b>9U-6249 Cylinder Tool Group (3600 Turbo) Service/Repair Parts</b>			
--	9U-6249	Cylinder Tool Group	--
2 <sup>1</sup>	9U-6244	Support	2
5	316-1493	Hydraulic Puller Group	1
6 <sup>1</sup>	9U-6251	Suspension Yoke Assembly	1
11	9U-6255	Removal Housing Assembly	1
13	1D-4614	Bolt	1
14	1D-5119	Jam Nut	1
15	9U-6256	End Plug	1
16	126-8290	Spanner Wrench	1
<b>Not shown</b>			
--	4C-9658 <sup>2</sup>	Case - Protective	1
--	9U-6685	Foam Block	1
--	9U-6686	Foam Block (top)	1
--	1U-7566	Hex Wrench	1
--	1U-7564	Hex Wrench, 5 mm	1

Item	Part Number	Description	Qty.
<b>9U-6250 Tool Group, Pump (3600 Turbo) Service/Repair Parts</b>			
--	9U-6250	Pump Tool Group	--
1	8F-0024	Hose Assembly	2
3	9U-6246	Adapter Assembly	1
4	1U-5230	Hand Pump	1
7	9U-6253	Removal Shaft Assembly	1
8	9U-6254	Installation Shaft Assembly	1
9	9U-7262	Plate	1
3	2J-3506	Nut	1
12	9U-6243	Extension Handle	1
17 <sup>1</sup>	9U-6248	Guide Bolt	3
<b>Not shown</b>			
--	4C-9664 <sup>3</sup>	Travel Vault	1
--	9U-6252	Foam Block	1
--	9U-6684	Foam Block (top)	1
--	7J-9108	O-ring Seal <sup>4</sup>	4
--	133-8951	Screw Thrust	--

<sup>1</sup> Part of 9U-5105 Basic Tool Group, 3600

<sup>2</sup> Fold-down handle

<sup>3</sup> Supplied with regular foam; Pick-N'Pluck is not available

<sup>4</sup> Part of 9U-6253 Removal Shaft Assembly and part of 9U-6254 Installation Shaft Assembly (both assemblies are part of 9U-6250 Pump Tool Group)

**195-8104 ABB Turbocharger Tool Kit (TPL61)**

Model: 3612 Marine Engines

Warranty: Six Months

- Used to disassemble and assemble ABB TPL61 turbochargers

**Reference**

REHS0811, Special Instruction, Disassembly and Assembly of TPL61 Turbocharger

Item	Description	Qty.
1	Tool Box	
2	Shackle	
3	Ring Bolt	2
4	Guide Tube	
5	Radial Bearing Pin	
6	Press On Bushing	
7	Bar	
8	Forcing Screw	4
9	Mounting Supports	2
10	Puller Screw	3
11	Stud	2
12	Press on Tool Assembly	2
Not shown	NEEG2923 Decal	

Part Number	Description
195-8104	ABB Turbocharger Tool Kit

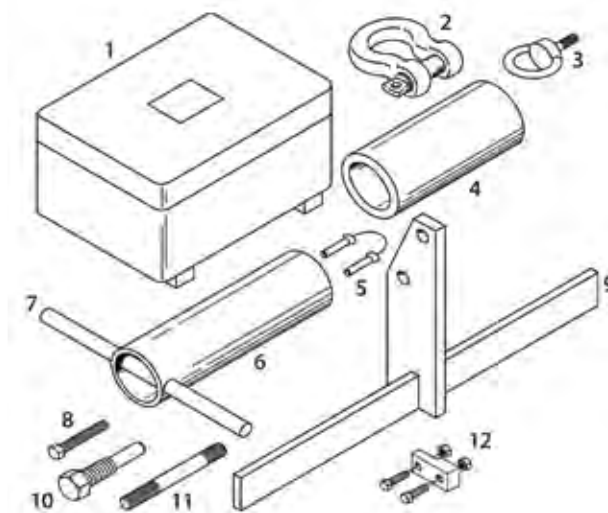
**187-3703 Tool Group (NA297)****Essential Tool**

Model: 3600 Engines

Warranty: Six Months

- Used to disassemble and assemble Napier NA297 Turbochargers

**Reference**

REHS0285, Special Instruction, Disassembly and Assembly of the Napier NA297 Turbocharger

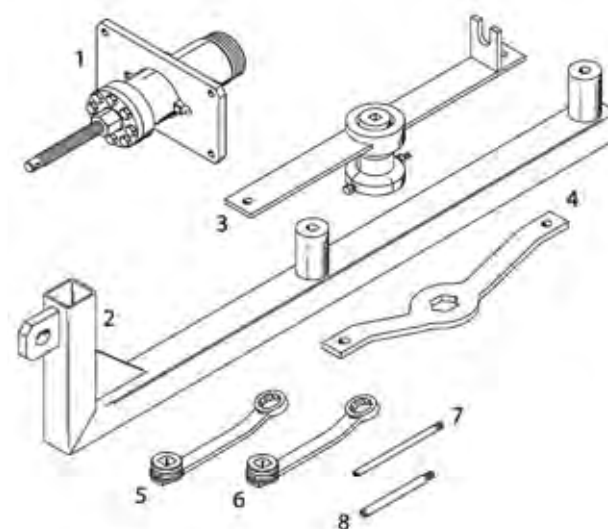

(Continued)

## 187-3703 Tool Group (NA297) (Continued)

### Essential Tool

Model: 3600 Engines

Warranty: Six Months

Item	Part Number	Description
--	187-3703	Tool Group (NA297)
1	177-9811	Turbo Thrust Collar Tool Group
2	177-9781	Turbo Compressor Lifting Bracket Assembly

Item	Part Number	Description
3	177-9856	Turbo Impeller Removal Tool Group
4	177-9791	Turbine Locking Tool
5	178-0193	Torque Adapter (30 mm)
6	178-0196	Torque Adapter (1 1/8 in)
7	177-9809	Turbo Bearing Guide Rod
8	177-9852	Insert Guide Rod

## 179-1904 Stud Tensioner Tool Group

### Essential Tool

Model: 3618 Engines

Warranty: Six Months

European Union compliant, CE marked

### Stud Tensioner Tool Group

- Used to simultaneously tension four cylinder head studs or two crankshaft main bearing cap studs
- Comes with seal kits for cylinder groups and pump group

### Cylinder Groups

- Smaller, lighter cylinders with convenient carrying handles
- Pistons return automatically when hydraulic pressure is released
- Gear driven turning sleeve allows stud nut rotation with 1/2 inch square drive ratchet

### Main Bearing Cap Handling Group

- Part of 179-1904 Stud Tensioner Tool Group
- Air cylinder raises and lowers main bearing caps for main bearing inspection or replacement
- Made of lightweight aluminum for easier use
- Allows one-person operation
- Ideal for tight engine compartments

### 160-0475 Support Tray

- Used to place 153-8488 Cylinder Group onto 156-7168 Main Bearing Cap Handling Group
- Used with 160-4901 Tray Support Rail
- Recommended but not included

### References

NEHS0762, Tool Operating Manual, Operation and Maintenance of the 179-1904 Stud Tensioner Tool Group Used on 3618 Engines

REN1333, Service Manual, Disassembly and Assembly of 3618 Engines

Hydraulic Pump (Electric)	
Maximum pressure	150 mPa (21,755 psi)
Voltage	230/400 V ( 50/60 Hz)
Weight	33 kg (73 lb)

(Continued)



**179-1904 Stud Tensioner Tool Group (Continued)**

**Essential Tool**

Model: 3618 Engines

Warranty: Six Months

Part Number	Description	Tensioning Force at Max. Pressure	Maximum Stroke	Overall Dimensions	Weight
153-8487	Stud Tensioner Cylinder Group (Cylinder Head)	1100 kN at 150 mPa (247,289 lb at 21,755 psi)	8 mm (0.31 in)	161.5 mm (6.36 in) high x 143.0 mm (5.63 in) diameter	9.6 kg (21.16 lb)
153-8488	Stud Tensioner Cylinder Group (Main Bearing)	2015 kN at 150 mPa (452,990 lb at 21,755 psi)	10.0 mm (0.32 in)	182.2 mm (7.17 in) high x 188 mm (7.4 in) diameter	18.2 kg (40.12 lb)
179-1904	Stud Tensioner Tool Group	--	--	--	--

**Stud Tensioner Tool Group**

Parts Included (not shown):
Socket Extension (1/2 in drive, 127 mm (5.0 in) long)
Swivel Head Ratchet (1/2 in drive)

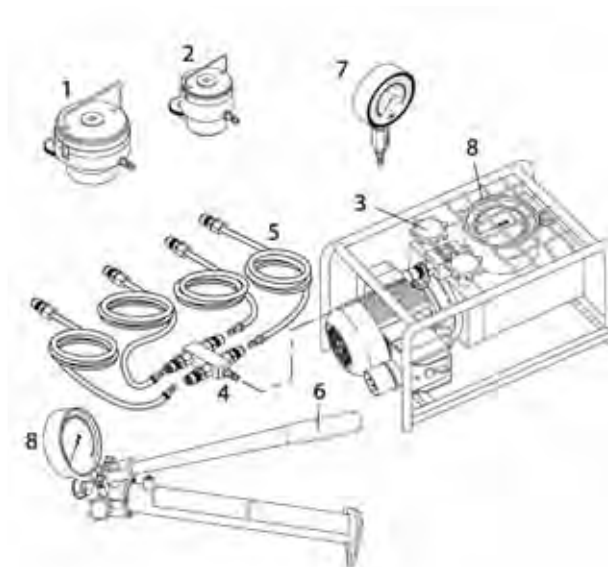

Item	Part Number	Description
1	153-8488	Stud Tensioner Cylinder Group (Main Bearing)
2	153-8487	Stud Tensioner Cylinder Group (Cylinder Head)
3	156-7166	Hydraulic Pump, Electric
4	178-9313	Distribution Coupler
5	178-9312	Hose Assembly
6	156-7167	Hydraulic Pump, Manual
7	185-0683	Comparison Gauge
8	185-4436	Pressure Gauge (service part for 227-6724, 227-8834, 1 and 191-5347 Pumps)

Item	Part Number	Description
<b>Not shown</b>		
--	178-9051	Bushing, M45 x 3 thread (Cylinder Head)
--	178-9058	Seal Kit (for 191-5322 Cylinder Head Cylinder Group)
--	175-0184	Bushing, M56 x 4 thread (Main Bearing)
--	175-0185	Sleeve (Main Bearing)
--	175-0191	Seal Kit (for 191-5323 Main Bearing Cylinder Group)
--	178-9314	Pump Seal Kit

Engine Tools

## Main Bearing Cap Handling Group

Engine Tools

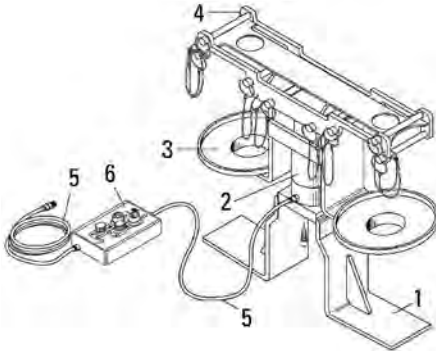

Item	Part Number	Description
<b>156-7168 Main Bearing Cap Handling Group (part of 179-1904 Stud Tensioner Tool Group)</b>		
1	160-0476	Bearing Cap Lift Base
2	160-0464	Air Cylinder
3	160-0473	Lift Assembly
4	178-9141	Bearing Cap Lift Bracket
5	5P-6011	Air Line
6	160-0465	Air Control Box

## 301-5215 Stud Tensioner Tool Group

## 229-9453 Pump Accessory Group

### Hydraulic Pumps

Model: All 3600 Engines Except 3618

Warranty: Six Months

European Union compliant, CE marked

- Used to simultaneously loosen or tighten nuts on four cylinder head studs or two crankshaft main bearing cap studs
- Used with 8T-0960 Handling Tool Group for easier removal and installation of main bearing caps
- Requires one 301-5215 Group, one 229-9453 Group, and one of optional pumps listed (cannot be used with any other pumps except the ones listed as item 10)
- Compact, lightweight cylinders have convenient carrying handles
- Optional gear drive permits faster installation of nut onto stud (1/2 inch square drive ratchet)
- ISO9001 Certified

### References

NEHS0866, Operation and Maintenance of Stud Tensioner Tooling Group used on 3600 Engines (except 3618)

SENR4259, Disassembly and Assembly G3606 and G3608 Engines

SENR5535, Disassembly and Assembly G3612 and G3616 Engines

SENR3600, Disassembly and Assembly 3606 and 3608 Engines

SENR3594, Disassembly and Assembly 3612 and 3616 Engines

Part Number	Description
301-5215	Stud Tensioner Tool Group
229-9453	Pump Accessory Group

## Basic Tooling Required for 301-5215 Stud Tensioner Tool Group

Item	Description	Qty.
6	Spanner Wrench	2
7	Swivel Head Ratchet (1/2 in square drive)	2

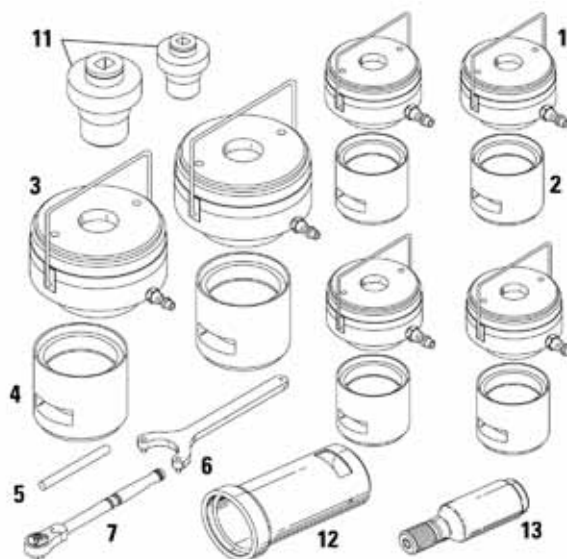

Item	Part Number	Description	Qty.
<b>301-5215 Stud Tensioner Tool Group (required)</b>			
1	191-5322	Cylinder Head Cylinder Group	4
2	191-5333	Cylinder Head Support	4
3	191-5323	Main Bearing Cylinder Group	2
4	191-5335	Main Bearing Support	2
5	9U-5141	Nut Turning Handle	2
11	191-5324	Bushing (for 191-5322 Group)	4

Item	Part Number	Description	Qty.
<b>301-5215 Stud Tensioner Tool Group (required) (Continued)</b>			
11	191-5326	Bushing (for 191-5323 Group)	2
12	225-5637	Support (used with 191-5322 and 191-5324)	2
13	225-5636	Adapter (used with 191-5322 and 191-5324)	2
<b>Not Shown</b>			
--	253-3272	Main Bearing Cylinder Group (C175)	2

**NOTE:**

Adapter and support bushing are required for front cylinder heads adjacent to support bracket. Taller adapter and support provides necessary clearance.

## Basic Tooling Required

Engine Tools

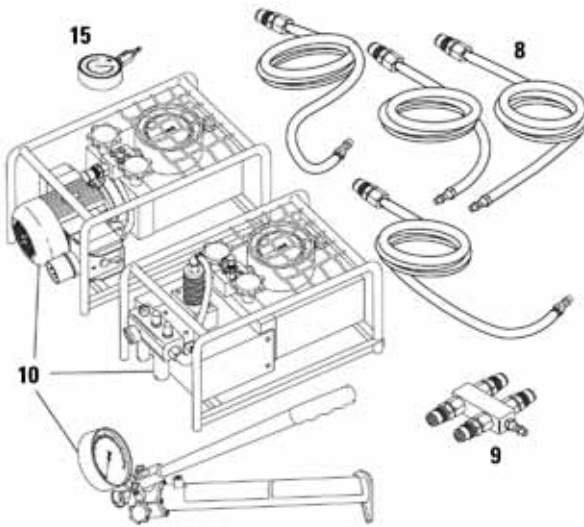

Item	Part Number	Description	Qty.
--	253-3274	Pump Accessory Group (Not shown)	--
<b>Pumps, Hose, and Coupler (requires one 229-9453 Group and one pump option)</b>			
10	227-6724	Hydraulic Pump, Electric, 120 V	1
10	156-7167	Hydraulic Pump, Manual	--
10	191-5347	Hydraulic Pump, Pneumatic	1

Item	Part Number	Description	Qty.
<b>Pumps, Hose, and Coupler (requires one 229-9453 Group and one pump option) (Continued)</b>			
10	227-8834	Hydraulic Pump, Electric, 240 V	1
<b>229-9453 Pump Accessory Group Includes:</b>			
8	178-9312	Hose Assembly	4
9	178-9313	Distribution Coupler	1
15	185-0683	Comparison Gauge	1
<b>253-3274 Pump Accessory Group Includes:<sup>1</sup></b>			
--	253-3276	Distribution Coupler	--

<sup>1</sup> Also includes part numbers 178-9312 and 185-0683

## Optional Tooling

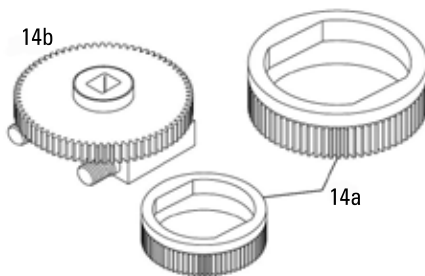

Item	Part Number	Description	Qty.
<b>Optional Gear Drive Group (permits faster rotation of nut onto stud)</b>			
14	191-5341	Gear Drive Group (optional, includes items 14a and 14b)	1
14a	191-5343	Turning Sleeve (for 191-5322 Cylinder Head Cylinder Group)	4
14a	192-4316	Turning Sleeve (for 191-5323 Main Bearing Cylinder Group)	2
14b	191-5342	Gear Drive Assembly	6

Service/Repair Parts

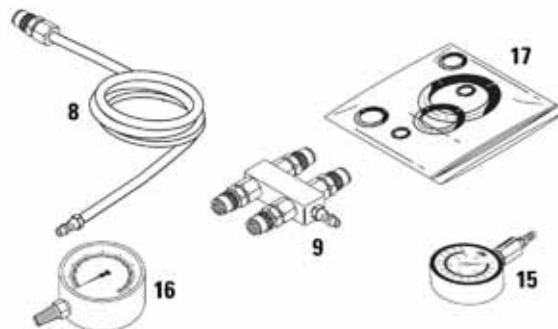

Engine Tools

Item	Part Number	Description	Qty.
<b>Service/Repair Parts</b>			
8	178-9312	Hose Assembly	1
9	178-9313	Distribution Coupler	1
15	185-0683	Comparison Gauge	1
16	185-4436	Pressure Gauge (service part for 227-6724, 227-8834, 1 and 191-5347 Pumps)	1
17	178-9058	Seal Kit (for 191-5322 Cylinder Head Cylinder Group)	1

Item	Part Number	Description	Qty.
<b>Service/Repair Parts (Continued)</b>			
17	175-0191	Seal Kit (for 191-5323 Main Bearing Cylinder Group)	1
17	227-6725	Seal Kit (for 227-6724 Pump and 227-8834 Pump)	1
17	194-8202	Seal Kit (for 191-5347 Pump)	1
<b>Not Shown</b>			
--	253-3275	Seal Kit (for 253-3272 Main Bearing Cylinder Group)	--
--	253-3276	Distribution Coupler	--

## Optional Tooling

Engine Tools

191-5322 Cylinder (Cylinder Head Studs)	
Maximum tensioning force	1100 kN (247,289 lb)
Maximum operating pressure	150 mPa (21,755 psi)
Effective piston surface	73.2 cm <sup>2</sup> (11.35 in <sup>2</sup> )
Stroke	10.0 mm (0.39 in)
Weight	9.5 kg (21 lb)
191-5323 Cylinder (Main Bearing Cap Studs)	
Maximum tensioning force	2015 kN (452,990 lb)
Maximum operating pressure	150 mPa (21,755 psi)
Effective piston surface	134.3 cm <sup>2</sup> (20.8 in <sup>2</sup> )
Stroke	10.0 mm (0.39 in)
Weight	19.5 kg (43 lb)
227-6724 and 227-8834 Electric Hydraulic Pump	
Oil quantity	3.8 L (0.84 gal)
Maximum operating pressure	150 mPa (21,755 psi)
Voltage, frequency	120/240 V, 60/50 Hz
Weight	33 kg (73 lb)
191-5347 Pneumatic Hydraulic Pump	
Oil quantity	4.0 L (0.88 gal)
Maximum operating pressure	150 mPa (21,750 psi)
Air pressure	3.5 - 8 bar (51 - 116 psi)
Air consumption	104 - 206 gpm
Weight	22 kg (48.5 lb)
Oil Specifications	
Oil viscosity at 50° C (122° F)	1.75 E-9.1 Centistokes
Oil temperature (maximum)	60° C (140° F)
Oil approval	HLP10 nach/acc.to VDMA 24318 bzw./resp. DIN51525

Part Number	Description
227-8834	Hydraulic Pump, Electric, 240 V
191-5347	Hydraulic Pump, Pneumatic
191-5322	Cylinder Head Cylinder Group
191-5323	Main Bearing Cylinder Group
227-6724	Hydraulic Pump, Electric, 120 V

## 160-0475 Support Tray

Model: 3618 Engines

Warranty: Six Months

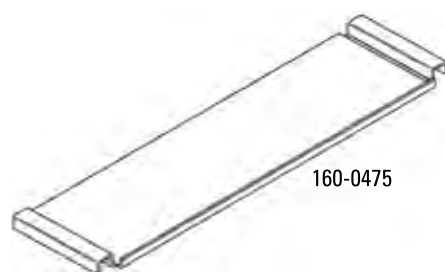

- Used to support 153-8488 Tensioning Cylinder being manually placed onto 156-7168 Bearing Cap Handling Group
- Tray support rail easily fits onto engine oil pan baffles

### Reference

REN1333, Service Manual, Disassembly and Assembly of 3618 Engines

Part Number	Description
160-0475	Support Tray

**160-4901 Support Tray Rail**

Model: 3618 Engines

Warranty: Six Months

- Used to support 153-8488 Tensioning Cylinder being manually placed onto 156-7168 Bearing Cap Handling Group
- Tray support rail easily fits onto engine oil pan baffles

**Reference**

REN1333, Service Manual, Disassembly and Assembly of 3618 Engines

Part Number	Description
160-4901	Support Tray Rail

