

# Body Electrical System

## General

Generals .....	BE - 3
Specifications .....	BE - 6
Diagnosis .....	BE - 7

## Fuses and Relays

Component Location .....	BE - 12
Components .....	BE - 14
Relay	
Inspection .....	BE - 16
Fuse	
Inspection .....	BE - 17

## Indicators and Gauges

Instrument Cluster	
Components .....	BE - 18
Circuit Diagram .....	BE - 20
Connector Configuration .....	BE - 23
Fuel Gauge	
Inspection .....	BE - 25
Water Temperature Gauge	
Inspection .....	BE - 26
Tachometer	
Inspection .....	BE - 27
Speedometer	
Inspection .....	BE - 28
Door Warning Indicator	
Inspection .....	BE - 29
Seat Belt Warning Indicator	
Inspection .....	BE - 30
Parking Brake Switch	
Inspection .....	BE - 31
Tilting Lock Sensor	
Inspection .....	BE - 32
Hazard Switch	
Inspection .....	BE - 33
Working Lamp Switch	
Inspection .....	BE - 34
Front/Rear Fog Lamp Switch	
Inspection .....	BE - 35
Idle Adjust Switch	
Inspection .....	BE - 36

## Multi Function Switch

Components .....	BE - 37
Inspection .....	BE - 38

## Windshield Wiper/ Washer

Component Location .....	BE - 40
Windshield Wiper/Washer	
Removal .....	BE - 41
Inspection .....	BE - 42
Circuit Diagram .....	BE - 42
Connector .....	BE - 42

## Power Windows

Power Window Motor	
Connector Configurations .....	BE - 43
Circuit Diagram .....	BE - 43
Inspection .....	BE - 43
Power Window Switch	
Inspection .....	BE - 44
Circuit Diagram .....	BE - 45

## Lighting System

Components .....	BE - 46
Head Lamp	
Replacement .....	BE - 47
Inspection .....	BE - 48
Adjustment .....	BE - 49
Turn Signal Lamp	
Replacement .....	BE - 51
Room Lamp	
Replacement .....	BE - 52
Fog Lamp	
Replacement .....	BE - 53
Inspection .....	BE - 53
Adjustment .....	BE - 54

## Head Lamp Leveling Device

Description .....	BE - 56
Components .....	BE - 56
Part Circuit Diagrams .....	BE - 57

## Keyless Entry System

Components .....	BE - 59
Description .....	BE - 60
Operation .....	BE - 61
Inspection .....	BE - 71
Adjustment .....	BE - 72
Specification .....	BE - 72
Door Lock Actuator	
Inspection .....	BE - 73

## **Digital Tachograph**

Specifications .....	BE - 74
Description .....	BE - 74
Components .....	BE - 75
Part Circuit Diagram .....	BE - 76
Replacement .....	BE - 77
DTC Chart .....	BE - 77

## **Audio System**

Audio Unit	
Components .....	BE - 78
Replacement .....	BE - 80
Cleaning .....	BE - 80
Speaker	
Replacement .....	BE - 81
Inspection .....	BE - 82

## **Horns**

Horns	
Component Location .....	BE - 83
Replacement .....	BE - 84
Inspection .....	BE - 84

## **Electronic Time And Alarm Control System**

Components .....	BE - 85
Circuit Diagram .....	BE - 86
Connector .....	BE - 88
Specifications .....	BE - 90
Generals .....	BE - 91
Operating Principle .....	BE - 91

## General

### Generals

1. For servicing the electric system, the battery (-) terminal should be disconnected first.

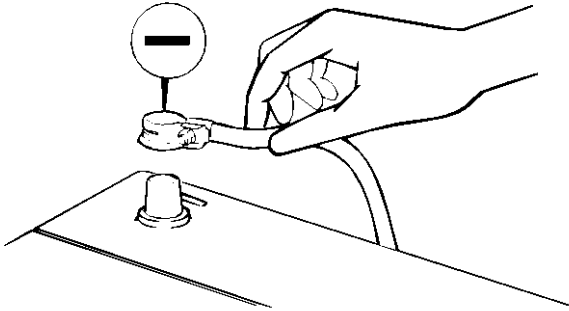

KMTBE5001A

#### **CAUTION**

Before connecting or disconnecting the (-) terminal, all lamp switches should be turn "OFF". (Otherwise, the semiconductor devices would be damaged)

2. If the harness can be contacted with a sharpened part or corner, wrap those portion with a tape for preventing the harness from being damaged.

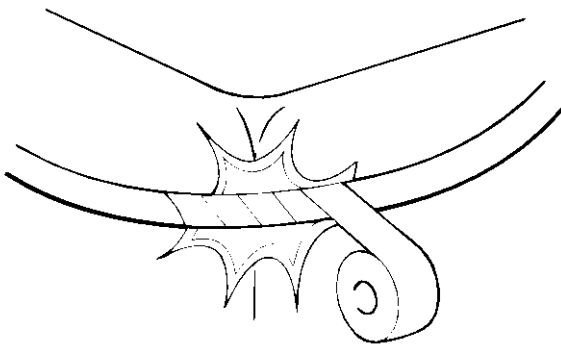

KMTBE5002A

3. When the parts are installed at the vehicle, be careful that the wiring harness is not torn off or damaged.

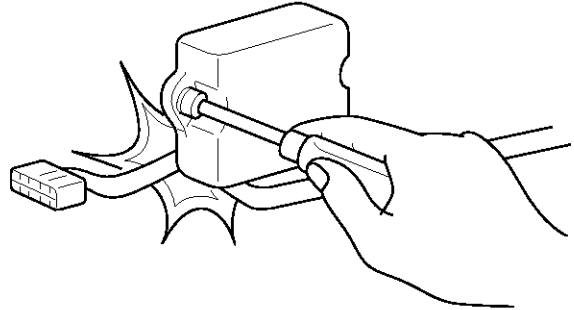

KMTBE5003A

4. When the fuse is burn-out, replace it with a new one of rated ampere. If one of higher than nominal capacity is used, the electric parts may be damaged or fire may be occurred.

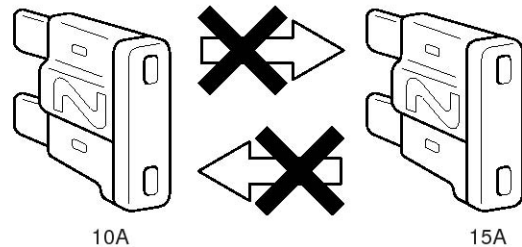

KMTBE5004A

- 5. Be careful that the sensors or the relays are not shocked. Do not drop them down to the floor. Do not throw them recklessly.

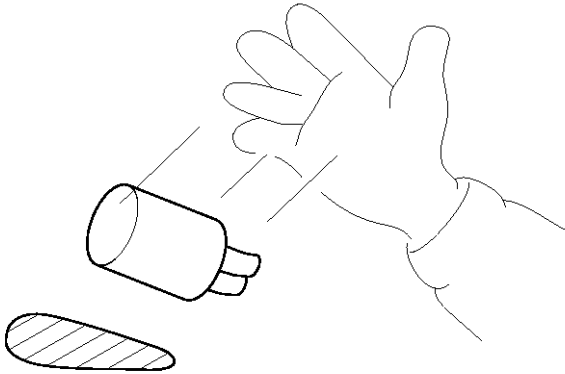

KMTBE5005A

- 6. As the electric components used for computer or relay are easily damaged by a heat, if the service is performed under the high temperature over 80°C, these electric components should be removed in advance.

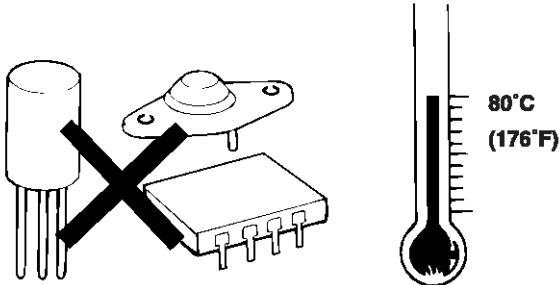

KMTBE5006A

- 7. As the loosened connector may be the causes of troubles, connecting of the connector should be ensured.

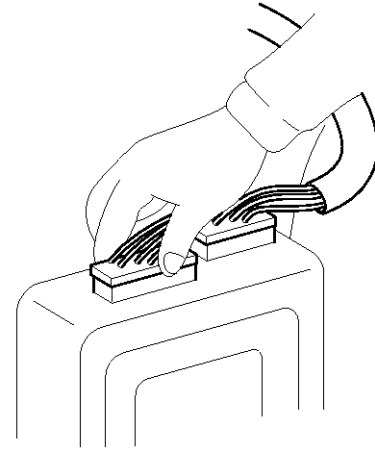

KMTBE5007A

- 8. When disconnecting the harness, hold the connector and pull it. Do not pull the harness to disconnect it.

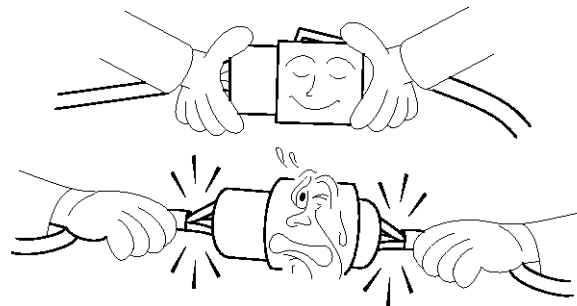

KMTBE5008A

- 9. When disconnect the connector having a locking device, press the lock to the arrow direction as shown in the following figure to remove the connector.

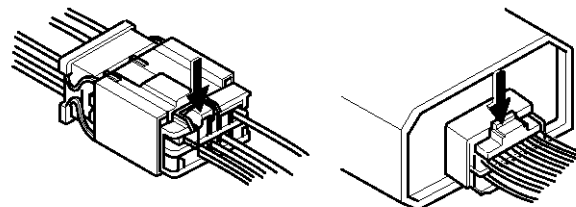

KMTBE5009A

10. When connecting the connector, insert the connector until "Tag" sound can be heard.

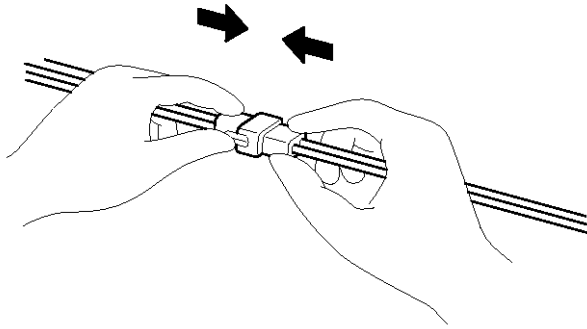

KMTBE5010A

11. When checking the electric current or voltage at the connector terminal using a circuit tester, insert the tester probe from the harness side. When the connector is the sealed type, insert the probe through the hole in the wiring rubber cap. At that time, be careful that the insulating of the wire is not damaged. Insert the probe until it contacts with the connector terminal completely.

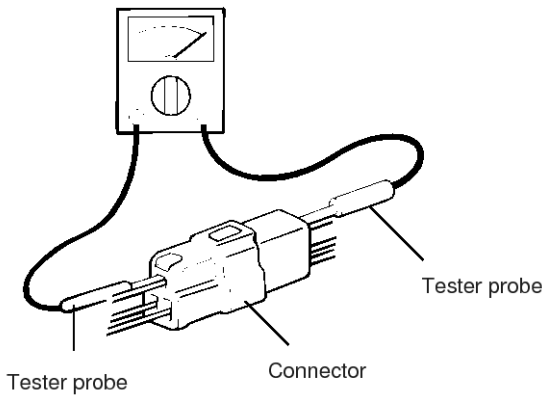

EMTBE5007A

## Inspection of Cable and Wire

1. Check that the connecting portion is loosened or rusted.
2. Check that the terminal or wire is corroded by the battery electrolyte.
3. Check that the circuit of the terminal or the wire is opened.
4. Check that the wire is properly insulated or the sheath is damaged, cracked or deteriorated.
5. Check that the conductive material of the wire contacts with metal parts of other components (body or other parts).
6. Check that the fixing bolt is electrically connected to the body completely.
7. Check that the wiring is properly performed.
8. Fix the wiring firmly to preventing it from contacting with the sharpened parts of body or the portions making a high temperature (exhaust manifold or exhaust pipe).
9. The wire should be fixed with enough clearance from the fan pulley, the fan belt and other rotating parts or vibrating parts.
10. The wiring between the body, the fixed part, and the engine, the vibrating part, should be fixed after distancing or slacking the wire somewhat.

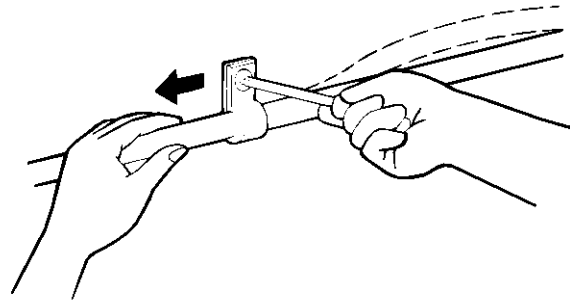

KMTBE5012A

## Specifications

	Item	Specifications	
Indicator and Gauge (Except D4GA engine)	Fuel gauge type Unit type	Cross coil type(Scale fixing type) Variable resistor type	
	Water temperature gauge type Unit type	Cross coil type (Middle fixing type) Thermistor type	
	Tachometer type Sensor type	Cross coil type Moving coil type	
	Speedometer type	Pulse type	
	Odometer type	Gear eddy current type	
	Indicator type	Bulb type	
Indicator and gauge (D4GA engine)	Fuel gauge type	Stepper motor	
	Water temperature gauge	Stepper motor(Middle fixing type)	
	Tachometer type	Stepper motor	
	Speedometer type	Stepper motor	
	Indicator type	LED type	
Multi function switch	Nominal voltage	DC 24V	
	Operating temperature range	-30~+80°C	
	Nominal load Dimmer and Passing switch Lightening switch Turn signal lamp switch Wiper switch Washer switch Exhaust brake Change of volume	0.12A (Relay load) 0.12A (Relay load) 21W x 2 + 1.7W (Lamp load) 0.12A (Relay load) 1.75A (Motor load) 0.8A (Coil load) Max 10mA	
	Insulating resistance	1MΩ or more at 500MV	
	Wind shield wiper/Wa- sher	Wiper motor type	Ferrite magnetic type
		Washer motor type	Ferrite magnetic type
		Washer tank capacity	2.8ℓ or more
	Power window	Power window motor Nominal voltage Operating temperature range	DC 24V -30~+70°C
Power window switch Nominal voltage Operating temperature range Power window switch nominal load current Power window switch max load current Window lock switch nominal load current (Driver's seat) Window lock switch max load current (Driver's seat)		DC 24V -40~+100°C 4A (Switch current) 4A (Switch current) 10A (Flowing current) 4A (Switch current) 10A (Flowing current)	

Item		Specifications
Lightening system	Lamp capacity	
	Head lamp (Up/Down)	75W/70W
	Turn lamp	21W
	Position lamp	5W
	Tail / Brake lamp	5/21W
	Room lamp	10W
	Fog lamp	70W
	Back up lamp	21W
	License plate lamp	12W
	Luminescent lamp	10W
Horn	Type	Flat type
	Nominal voltage	DC 24V
	Frequency	415 ± 20Hz
	Decibel	100~112 dB
Cigar lighter	Type	Bimetal Type
	Nominal voltage	DC 24V
	Nominal current	5A
	Returning time after pressing the plug	13 ± 5 sec.

## Diagnosis

### Ignition Switch

Symptom	Causes	Remedy
When turning the ignition switch to the S-TART, the starter is not working.	The ignition switch is faulty.	Replace
	The battery is discharged.	Charge
	The starter relay or the starter is faulty.	Replace
	The starter fuse is short.	Replace
	The wiring circuit is opened or the contact is faulty.	Repair

## Lighting System

Symptom		Causes	Remedy
General Light	When turning the switch ON, the lamp is not lightened.	The bulb is short.	Replace
		The battery is discharged.	Charge
		The switch is faulty.	Replace
		The fuse is short.	Replace
		The wiring circuit is opened or the contact is faulty.	Repair
	Lamp is dark.	The life time of bulb is over or the bulb is faulty.	Replace
		The battery is discharged.	Charge
		The switch does not properly contact.	Replace
		The wiring or terminal is faulty in contact.	Repair
	Head Lamp	The head lamp is not working.	The lamp switch is faulty.
The dimmer switch is faulty.			Replace
The head lamp relay is faulty.			Replace
Turn, Hazard Lamp	The lamp is not blinking.	The switch of turn or emergency lamp is faulty.	Replace
		The blinking relay is faulty.	Replace
	The lamp is lightening continually.	The blinking relay is faulty.	Replace
	The blinking interval is too long.	The power of the bulb is lower than nominal.	Replace
		The blinking relay is faulty.	Replace
	The blinking interval is too short.	The bulb is short.	Replace
		The blinking relay is faulty.	Replace
Other Lamp	The brake lamp is not lightening.	The brake lamp switch is faulty.	Replace
		The brake lamp switch is not installed properly.	Repair
	The tail lamp, position lamp or the number plate lamp is not lightening.	The light switch is faulty.	Replace
		The tail lamp relay is faulty.	Replace
	Back up lamp is not lightening.	Back up lamp switch is faulty.	Replace
		The Back up lamp switch is not installed properly.	Repair
	The fog lamp is not lightening.	The fog lamp switch is faulty.	Replace
		The fog lamp relay is faulty.	Replace



## Meter and Gauge

Symptom	Causes	Remedy
The speedometer does not work.	The speed sensor is faulty.	Replace
	The fuse is opened or blow.	Replace
	The speedometer is faulty.	Replace
The needle of the speedometer is unstable.	The speed sensor is faulty.	Replace
	The speedometer is faulty.	Replace
The tolerance of the speedometer is too large.	The tire size is not proper.	Replace
	The speedometer is faulty.	Replace
The tachometer does not work.	The tachometer sensor is faulty.	Replace
	The tachometer is faulty.	Replace
	The fuse is short.	Replace
The needle of the tachometer is unstable, or its tolerance is too large.	The tachometer sensor is faulty.	Replace
	The tachometer is faulty.	Replace
	The wiring is faulty	Replace
The coolant temperature gauge does not work.	The fuse is short.	Replace
	The coolant temperature gauge is faulty.	Replace
	The coolant temperature gauge unit is faulty.	Replace
The needle of the coolant temperature gauge is unstable, or its tolerance is too large.	The coolant temperature gauge is faulty.	Replace
	The coolant temperature gauge unit is faulty.	Replace
	The wiring is faulty.	Repair
	The thermostat is faulty.	Replace

## Indicating and Warning Lamp System

Symptom	Causes	Remedy
When switch is ON, each unit is working but the indicating lamp is not lightened.	The bulb is open.	Replace
	The wiring circuit is opened, or it contact is faulty.	Repair
	The switch is working abnormally.	Replace
When the parking brake knob is pulled, the brake lamp is not lightened.	The bulb is short.	Replace
	The spring brake switch is faulty.	Replace
	The fuse is short.	Replace
	The wiring circuit is opened, or it contact is faulty.	Repair
After releasing the parking brake, the brake lamp is not off.	The spring brake switch is faulty.	Replace
	The wiring is faulty.	Repair

Symptom	Causes	Remedy
The brake lamp does not work.	The bulb is short.	Replace
	The fuse is short.	Replace
	The wiring circuit is opened, or its contact is faulty.	Repair
During working of engine, the oil warning lamp turns on.	The engine oil pressure is too low.	Adjust
	The engine oil is leak or its level is too low.	Adjust
	The oil pressure switch is faulty.	Replace
	The oil filter is clogged.	Replace element
During working of engine, the charging warning lamp turns on.	The V-belt is sagging or broken.	Replace or adjust
	The alternator is faulty.	Repair
The overheat warning lamp turns on.	The coolant water is not enough.	Adjust
	The overheat sensor is faulty.	Replace

**Wiper**

Symptom	Causes	Remedy
The wiper does not work.	The wiper motor is faulty.	Replace
	The wiper switch is faulty.	Replace
	The fuse is short.	Replace
	The wiring circuit is opened, or its contact is faulty.	Repair
The wiper can not stop.	The wiper switch is faulty.	Replace
	The wiper motor is faulty.	Replace
The wiper does not perform the intermittent operation.	The ETACS is faulty.	Replace
	The wiper switch is faulty.	Replace
The blade does not stop on proper position.	The wiper link is positioned abnormally.	Adjust
	The wiper motor is faulty.	Replace
The wiping condition is faulty.	The blade is faulty.	Replace
	The wiper arm is faulty.	Replace
During working, the wiper makes an abnormal noise.	The wiper motor is faulty.	Replace
	The blade is faulty	Replace
	The wiper link or the wiper arm contact is faulty.	Repair

## Washer System

Symptom	Causes	Remedy
The washer motor does not work.	The washer motor or pump is faulty.	Replace
	The washer switch is faulty.	Replace
	The fuse is short.	Replace
	The wiring circuit is opened, or its contact is faulty.	Repair
The spraying amount of the washer liquid is too small.	The hose is twisted.	Adjust
	The washer nozzle is clogged.	Clear
	The washer motor or pump is faulty.	Replace
The washer liquid is not sprayed.	The jointing of hose is faulty.	Repair
	The washer nozzle is clogged.	Clear
	The washer motor or pump is faulty.	Replace
	The level of washer liquid is too low	Refill

Fuses And Relays

Component Location (Except D4GA engine)

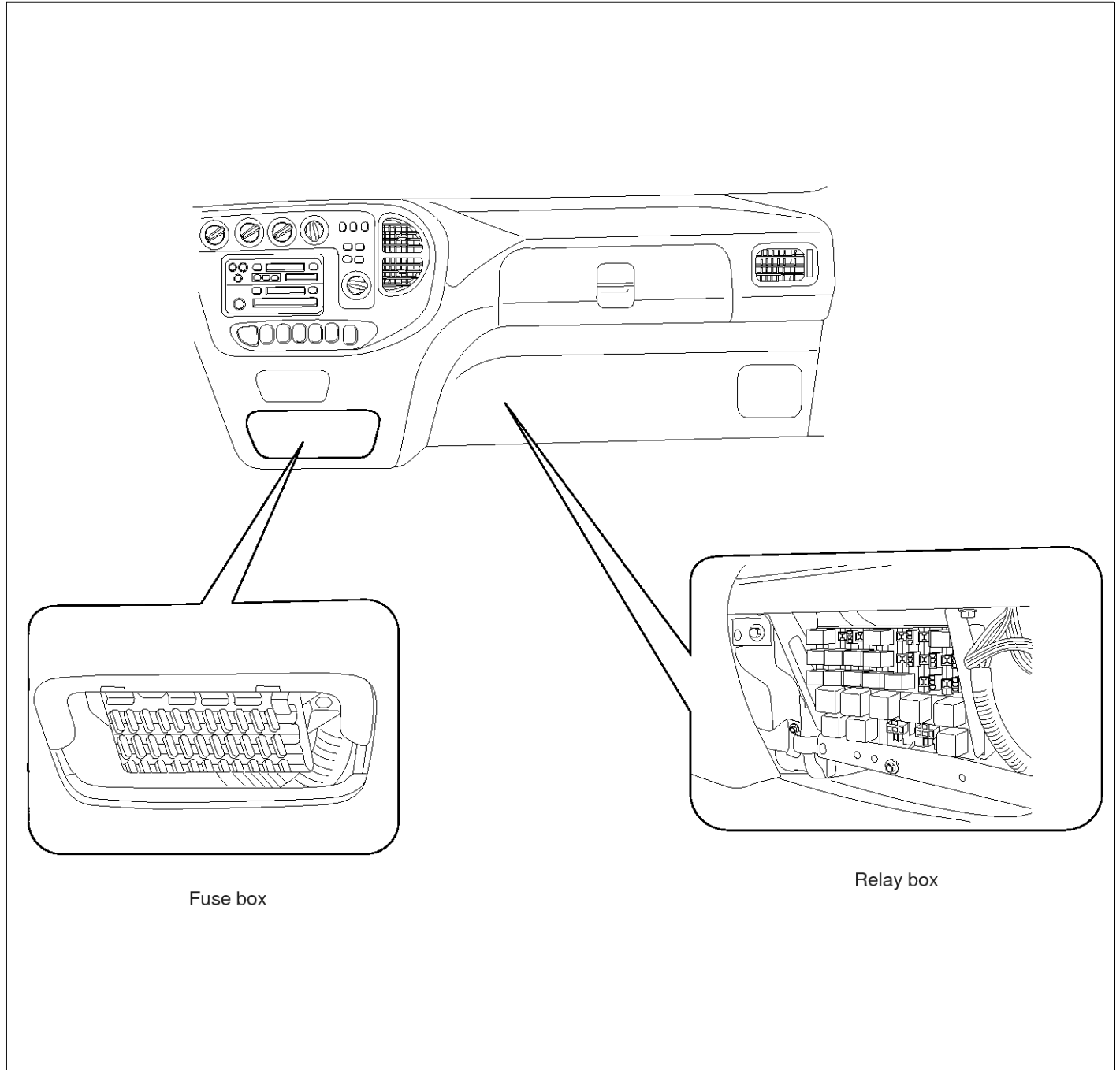

Fuse box

Relay box

## Component (D4GA engine)

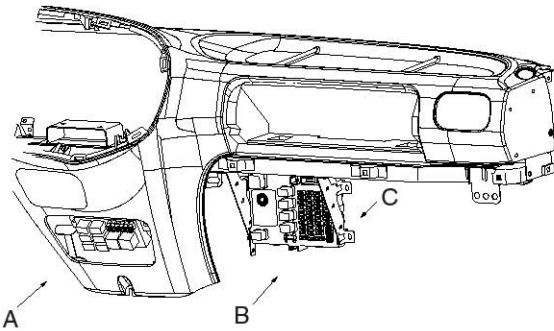

[ LHD ]

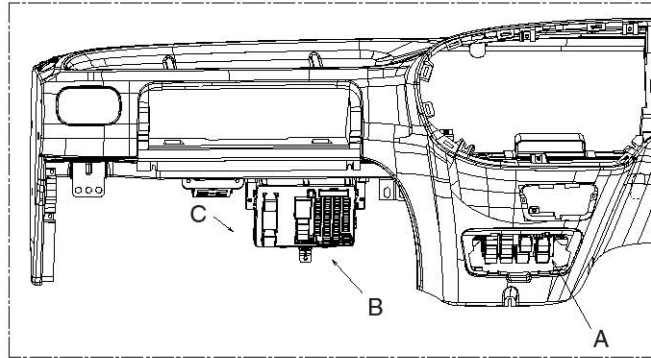

[ RHD ]

### Fuse & relay box

HEAT MIRROR		HLLD 5A	REAR FOG LP 5A						
T/SIG LH (KEYLESS)	T/SIG LH (KEYLESS)			SPARE 5A			FUSE PULLER		
		START INHIBIT		START					
BURGLAR ALARM									

1. USE DESIGNATED FUSE & RELAY ONLY.  
 2. TURN OFF THE KEY SWITCH WHEN EXCHANGING FUSE & RELAY  
 3. DO NOT FLOOD OR KICK.

[ A ]

### Front of junction box

		FRONT OF JUNCTION BOX					
POWER WINDOW	EXH BRAKE	FUEL HEATER 20A	STARTER 5A	HEATER 15A	HEAD LP(DIM,LH) 10A		
		POWER WINDOW 20A	ENG ECU 5A	AIRCON COND 20A	HEAD LP(DIM,RH) 10A		
FOG LP	FOG LP	FOG LP 10A	ABS 5A	HEAD LP RELAY 5A	ENG ECU 5A		
			EXH BRAKE DTG 10A	IND/RES BRAKE 5A	HEAD LP(MAIN,RH) 10A		
DOOR LOCK	DOOR LOCK	CENTRAL LOCK 10A		WIPER 15A	HEAD LP(MAIN,LH) 10A		
		ENG ECU 20A	CIGAR,AUDIO 15A	AIRCON 10A	TAIL LP(LH) 10A		
TAIL LP	DOOR OPEN	STOP LP, HORN 10A	P.T.O 5A	WORKING LP 15A	TAIL LP(RH) 15A		
		TURN SIG 10A	ALTR. REVERSE LP SPEED 10A	CLUSTER ETACS 10A			
		ENG ECU 5A	HEAT MIRROR 15A	P.T.O	FUSE PULLER		
		ROOM LP 10A	DOOR SW(LH)	DOOR SW(RH)			
		KEYLESS 10A	SPARE 5A	SPARE 10A	SPARE 10A	SPARE 15A	SPARE 20A

USE THE DESIGNATED FUSE ONLY

[ B ]

### Back of junction box

BACK OF JUNCTION BOX			
Head lamp (Dimmer)	Wiper (High)	Glow	Fuel heater
Head lamp (Main)			
PTO	Wiper (Low)	Horn	Engine EUC

USE THE DESIGNATED RELAY

[ C ]

## Component(Fuse)

Except D4GA engine

### Fuse box

1 15A	2 5A	3 10A	4 10A	5 15A	6 5A	7 5A	8 10A	9 10A	10 15A	11 10A	12 10A
13 20A	14 10A	15 10A	16 10A	17 10A	18 15A	19 15A	20 20A	21 20A	22 10A	23 10A	24 15A
25 10A	26 10A	27 10A	28 10A	29 10A	30 10A	31 10A	32 5A	33 15A	34 15A	35 10A	36 15A

Fuse	Amperages	Circuit protected	Fuse	Amperages	Circuit protected
1	15A	Working lamp	19	15A	Outside mirror defogger
2	5A	Head lamp relay	20	-	-
3	10A	Blower and A/C control	21	20A	Fuel heater
4	10A	Exhaust brake, tachograph(EC), Cold start switch	22	10A	-
5	15A	Wiper and washer	23	10A	Tachograph, ETACS, audio, instrument cluster, room lamp
6	5A	ABS control(ECU)	24	15A	Starting
7	5A	PTO	25	10A	Head lamp(LOW)_LH
8	-	-	26	10A	Head lamp(LOW)_RH
9	10A	Sub start	27	10A	Head lamp(HIGH)_LH
10	-	-	28	10A	Head lamp(HIGH)_RH
11	10A	Vehicle speed sensor, Back up lamps	29	10A	LH Tail lamp
12	10A	ETACS, Instrument cluster	30	10A	RH Tail lamp
13	20A	Power window	31	10A	Front fog lamp
14	10A	Stop lamp, horn, data link connector	32	5A	Engine ECU
15	10A	Cab tilting switch, hazard lamps	33	15A	Condenser fan relay, A/C relay
16	10A	RR FOG lamp	34	15A	Heater blower
17	10A	Power door lock(unlock)	35	10A	12V converter, ETACS
18	15A	ABS control(valve)	36	15A	Instrument cluster, audio, cigarette lighter, clock

### CAUTION

Use the designated fuse only.

## Components(Relay, Fuse blink)

### Relay

Front Fog Lamp Relay	-	-	-	-	-	-
EXH Brake cut off (ABS) Relay	Central door locking relay	Central door locking relay	Heat'G mirror relay	Washer motor relay	Horn relay	-
PTO Relay	Dump warning relay	Left turn signal relay	Right turn signal relay	Exhaust brake relay	Glow relay	Heated seat relay
	Wiper relay (HIGH)	Wiper relay (LOW)	Head lamp relay (MAIN)	Head lamp relay (DIMMER)	Power window relay	
	Start inhibit relay	Fuel heater relay	Engine ECU relay	-	Tail lamp relay	

### <25A Alternator>

Generator	Ignition
<b>60A</b>	<b>30A</b>
Body	A/Con
<b>40A</b>	<b>30A</b>

**※ Use the designated fuses only.**

### <40, 50A Alternator>

ABS	
<b>30A</b>	
A/Con	Body
<b>30A</b>	<b>40A</b>
Ignition	Generator
<b>30A</b>	<b>50A</b>

**※ Use the designated fuses only.**

Description		Amperages (A)	Circuit protected
Fusible Link	Ignition	30A	Ignition switch
	A/C	30A	Fuse 33, 34
	ABS	30A	ABS relay box
	Generator	60A	Generator
	Body	40A	Head lamp relay (HIGH), Head lamp relay (LOW), Tail lamp relay, Fuse 13~21, Fuse 22,23,31

## Relay

### Inspection

#### Type A relay

- When an electric power is applied between the power relay terminal No.2 and No.4, check that there is an electric current between the terminal No.1 and No.5.

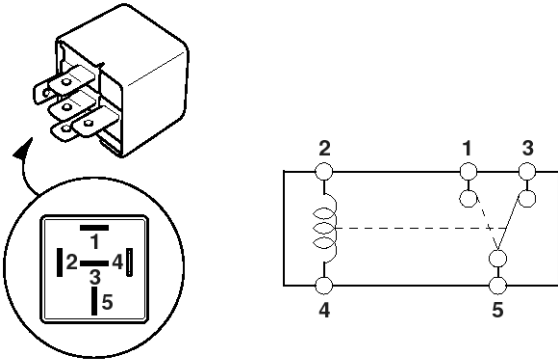

KMTBE5015A

- When the electric power applied between the power relay terminal No.2 and No.4 is off, check that there is an electric current between the terminal No.1 and No.5.

Terminal	1	2	3	4	5
Position					
At power applied	○	—	—	—	○
At power Off			○	—	○

EMTBE5010A

#### Type B relay

- When an electric power is applied between the power relay terminal No.3 and No.5, check that there is an electric current between the terminal No.1 and No.2.

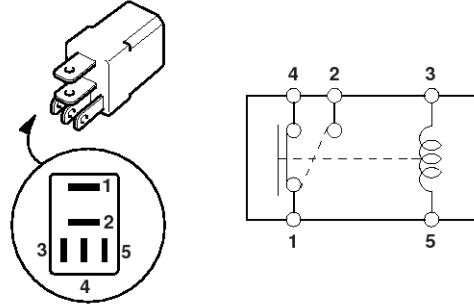

KMTBE5016A

- When the electric power applied between the power relay terminal No.3 and No.5 is off, check that there is an electric current between the terminal No.1 and No.4.

Terminal	1	2	3	4	5
Position					
At power applied	○	○			
At power Off	○			○	

EMTBE5011A



## Fuse

### Inspection

1. When a fuse is burnt-out, check that there is any opened or abnormal component before replacing the fuse. After replacing the opened or abnormal parts, install a new fuse of the same ampere.

Blown fuse due to overcurrent

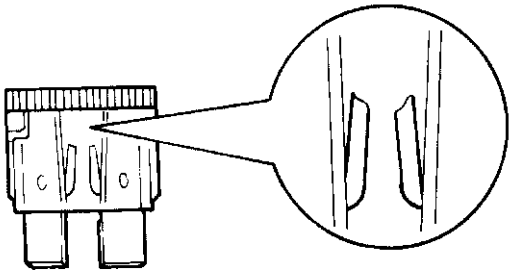

EMTBE5012A

2. When the fuse is intermittently disconnected, it means that the fuse does not satisfy the nominal capacity. If this fuse is used for a long time, it causes a trouble. At this case, replace with a new one of the nominal ampere.

Blown fuse due to thermal fatigue

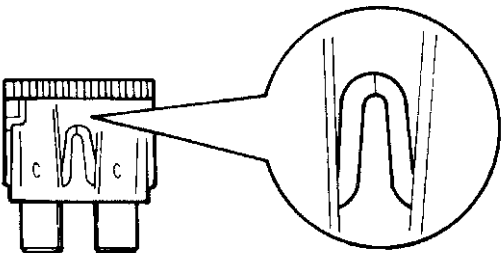

EMTBE5013A

3. A blade type fuse is identified by the numbered value in amperes.

If the fuse is burnt-out, be sure to replace a fuse with the same ampere rating. If a fuse of higher capacity than specified is used, parts may be damaged and the danger of fire also exists.

To remove or insert a fuse, please use the fuse puller in the fuse box.

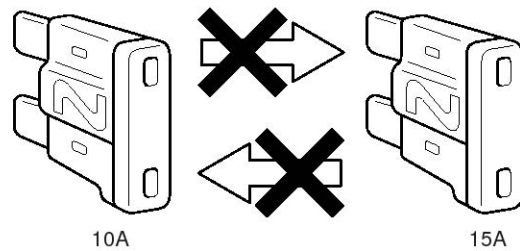

KMTBE5004A

## Indicators And Gauges

### Instrument Cluster

#### Components (Except D4GA engine)

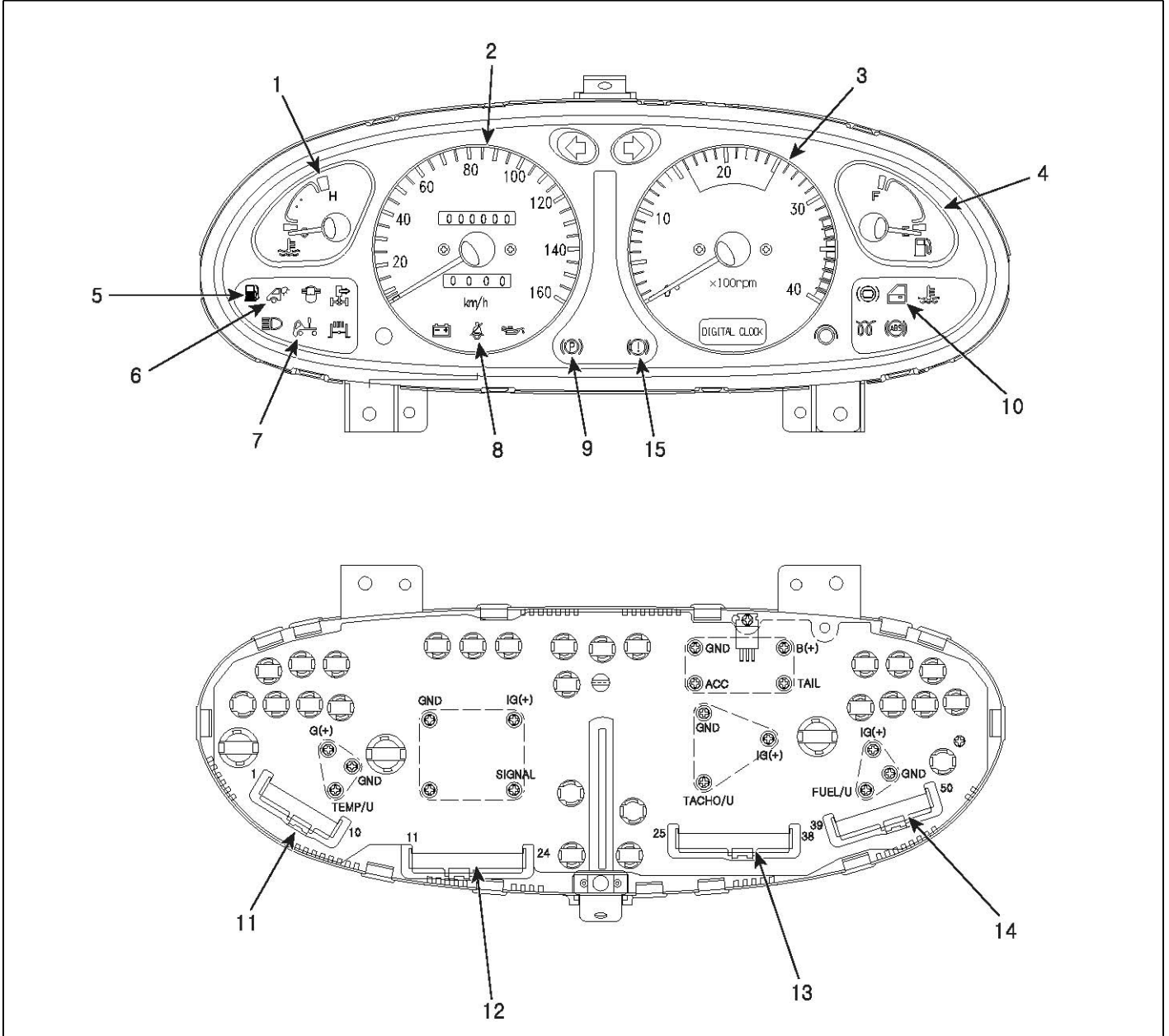

SUDBEA0050L

- |                      |                               |                            |
|----------------------|-------------------------------|----------------------------|
| 1. Temperature gauge | 6. Working lamp               | 11. 1st Connector          |
| 2. Speedometer gauge | 7. Tilting lock warning lamp  | 12. 2nd Connector          |
| 3. Tachometer        | 8. Seat belt warning lamp     | 13. 3rd Connector          |
| 4. Fuel gauge        | 9. Parking brake warning lamp | 14. 4th Connector          |
| 5. Fuel warning lamp | 10. Door warning lamp         | 15. Brake oil warning lamp |

## Components (D4GA engine)

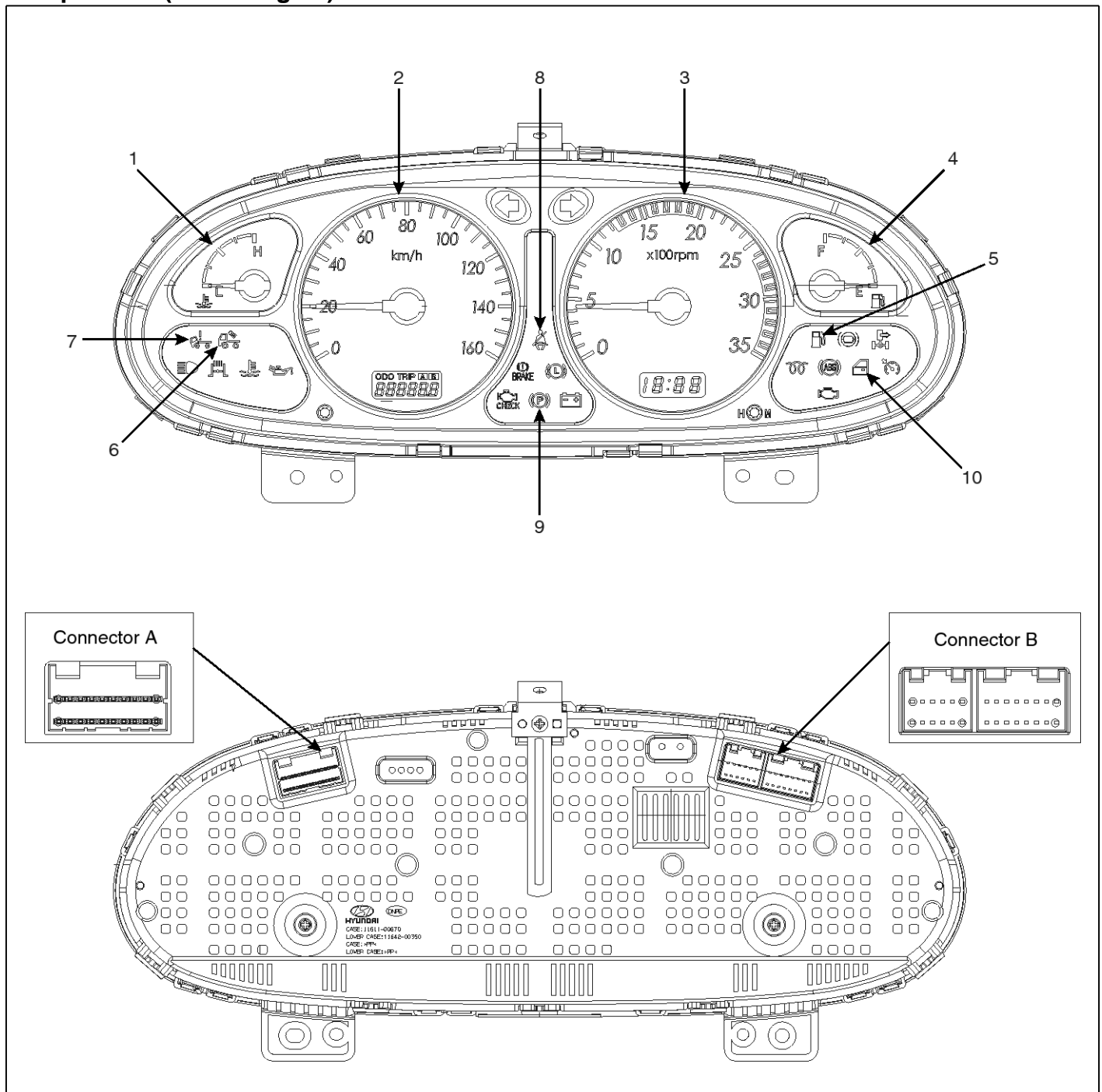

SUDBEA0051L

- |                            |                               |
|----------------------------|-------------------------------|
| 1. Water temperature gauge | 6. Working lamp               |
| 2. Speedometer gauge       | 7. Tilting lock warning lamp  |
| 3. Tachometer              | 8. Seat belt warning lamp     |
| 4. Fuel gauge              | 9. Parking brake warning lamp |
| 5. Fuel warning lamp       | 10. Door warning lamp         |

## Circuit Diagram (Mechanical engine)

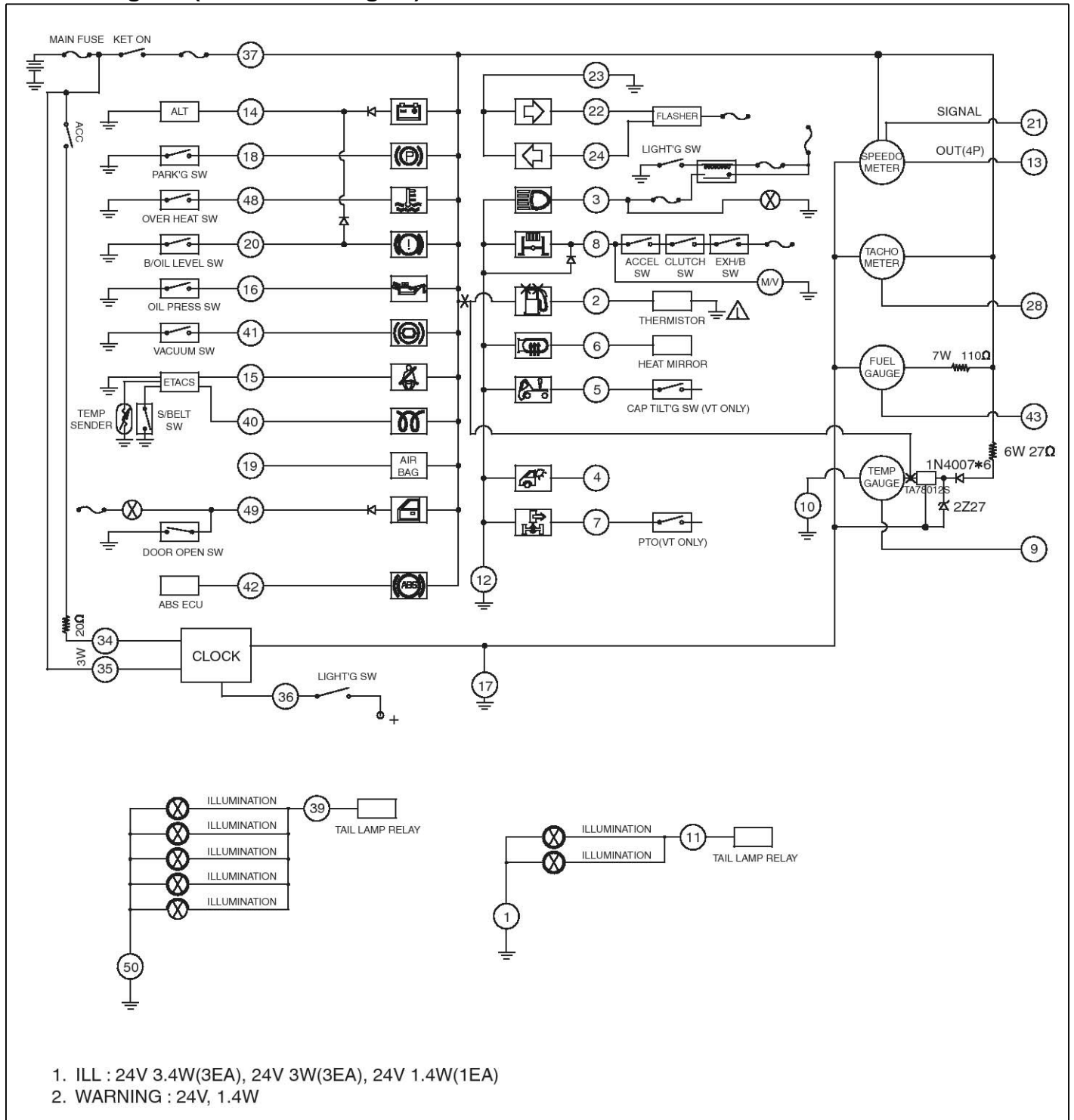



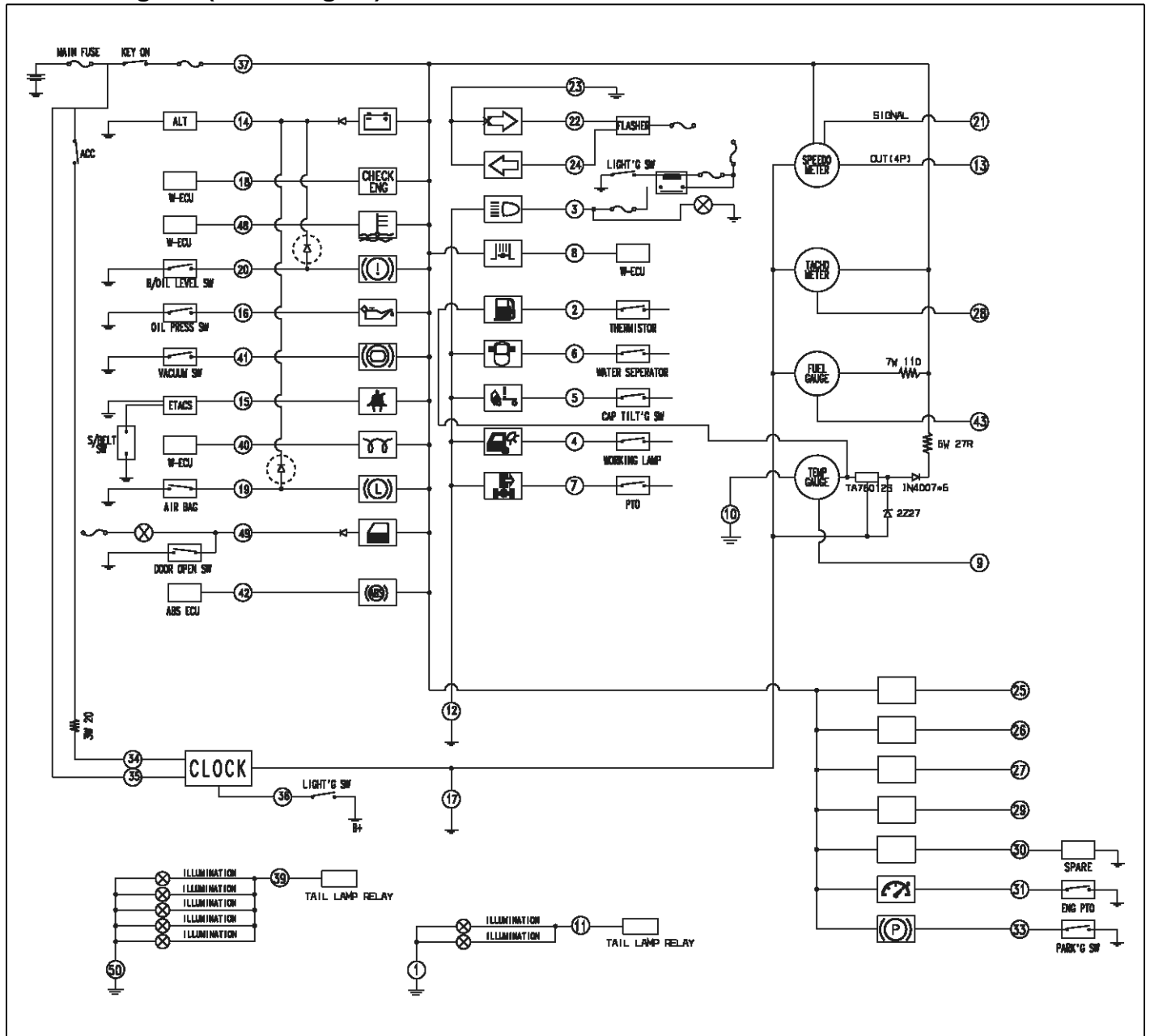

## Circuit Diagram (D4DD engine)

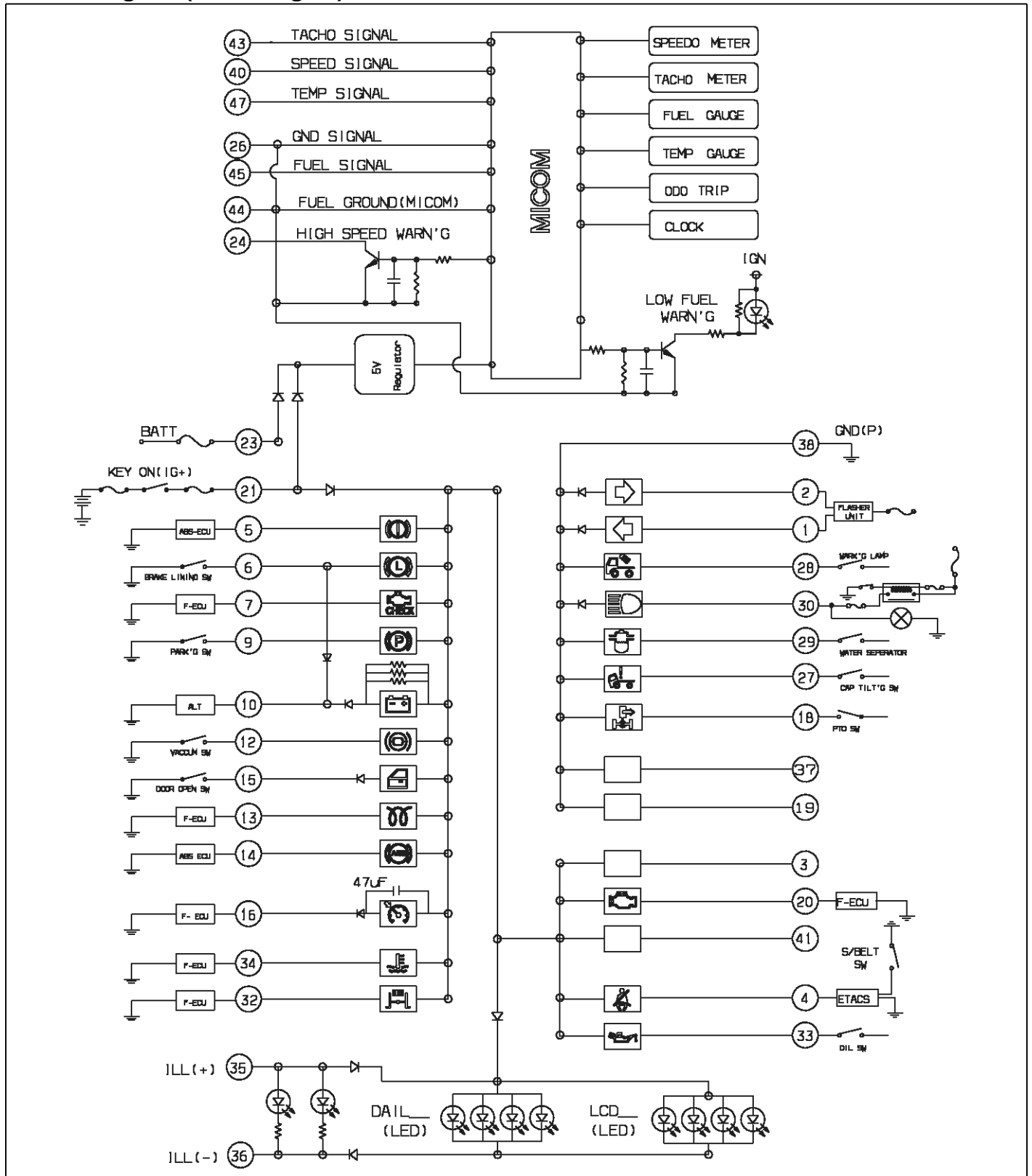

Circuit Diagram (D4GA engine)

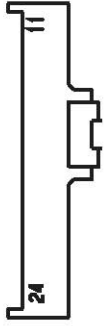

## Connector Configurations (Except D4GA engine)

Pin NO.	Name	Connector	Pin NO.	Name	Connector
1	ILLUMINATION(-)	 1st Connector	25	-----	 3rd Connector
2	LOW FUEL		26	-----	
3	HI-BEAM		27	-----	
4	WORKING LAMP		28	TACHO SIG	
5	CAP TILT'G SW		29	-----	
6	HEATED MIRROR		30	-----	
7	PTO		31	-----	
8	EXE BRAKE		32	-----	
9	TEMP SENDER		33	-----	
10	EARTH(TEMP GAUGE)		34	ACC(CLOCK)	
11	ILLUMINATION(+)	 2nd Connector	35	BATT(+)	 4th Connector
12	EARTH		36	TAIL	
13	S/M OUT(4P)		37	KEY ON	
14	ALTERNATOR		38	-----	
15	SEAT BELT SW(ECU)		39	ILLUMINATION(+)	
16	ENGINE OIL		40	PRE HEAT	
17	EARTH		41	VACCUM	
18	PACKING SW		42	ABS	
19	AIR BAG		43	FUEL SENDER	
20	BRAKE OIL		44	-----	
21	S/M SIGNAL		45	-----	
22	R/TURN SIG		46	-----	
23	EARTH(TURN)		47	-----	
24	L/TURN SIG		48	OVER HEAT SW	
		49	DOOR		
		50	ILLUMINATION(-)		

## Connector Configurations (D4GA engine)

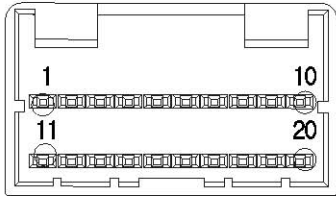

Connector A

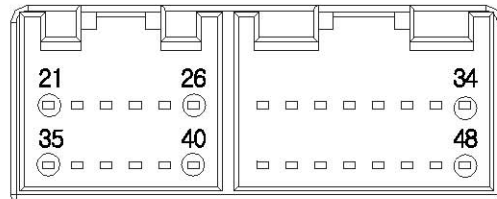

Connector B

1	Turn-LH	11		21	Key ON(IG)	35	ILL(+)
2	Turn-RH	12	Vaccum	22		36	ILL(-)
3	Spare	13	Pre heat	23	B+	37	Spare
4	Seat belt	14	ABS	24	High speed warning	38	GND(P)
5	Brake oil level	15	Door	25		39	
6	Brake lining	16	Engine PTO	26	GND(S)	40	Speed signal
7	Check engine	17		27	Cap tilting	41	Spare
8		18	PTO	28	Working lamp	42	
9	Parking	19	Spare	29	Water seperator	43	Temp signal
10	ALT	20	MIL	30	H-beam	44	Tacho signal
				31		45	Fuel/G GND
				32	Exhaust brake	46	
				33	Engine oil	47	Fuel signal
				34	Over heat SW	48	



## Fuel Gauge

### Inspection

#### Inspection of Fuel Gauge

1. Disconnection the fuel sender connector.
2. After connecting the test bulb to the connector of the harness in serial, and ground it.
3. Turn the ignition switch to the "ON" position.
4. Check that the test bulb is lightened or the needle of the fuel gauge is slowly moving to the "F" position.

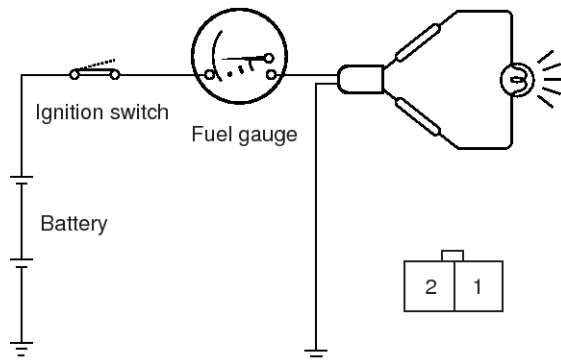

EMTBE5015A

5. If the needle of the fuel gauge is not moving, replace the cluster.

#### Inspection of Fuel Sender

1. Setting the float to the "F" and "E" positions, measure the resistor between the terminal No.1 and No.2, respectively.

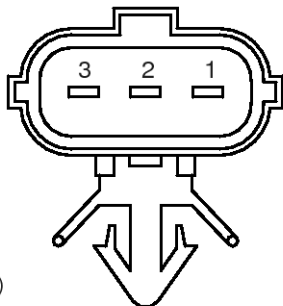

- 1 : Sender(+)
- 2 : Ground
- 3 : Warning lamp

EMTBE5016A

2. Check that the resistor is varying smoothly, when the float is moving from "F" to "E" position.

Except D4GA engine

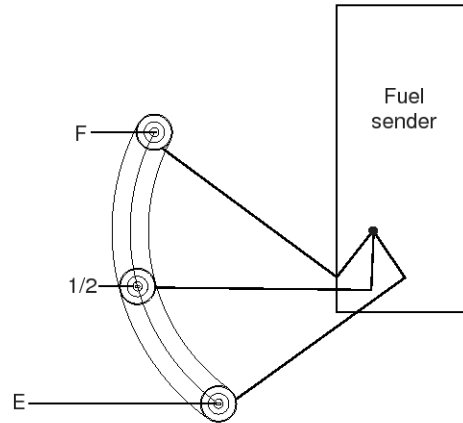

EMTBE5017A

Float Position	F	1/2	E
Reference R( $\Omega$ )	4	32	105
Tolerance of R( $\Omega$ )	$\pm 2$	$\pm 5$	$\pm 2$

D4GA engine

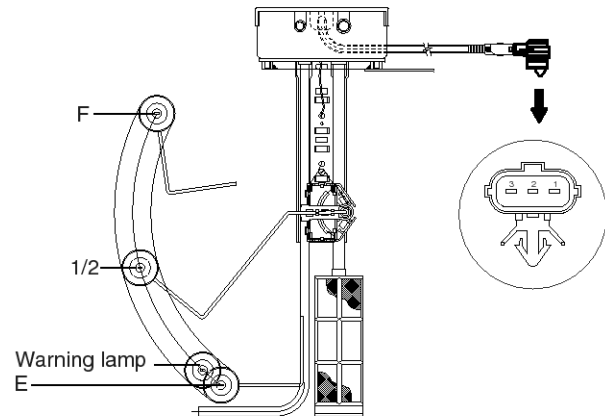

SUDBEA0038L

Float Position	S / F	1/2	Warning lamp	S / E
Reference R( $\Omega$ )	7	32	88	105
Tolerance of R( $\Omega$ )	$\pm 2.5$	$\pm 2.5$	$\pm 2.5$	$\pm 2.5$

## Water Temperature Gauge

### Inspection

#### Inspection of water temperature gauge and water temperature sensor

1. If it is not satisfied the tolerance, replace the cluster and water temperature sensor.

Except D4GA engine

Temperature (°C)	57	85~105	120
Scale Angle (°)	-40	-7	34
Tolerance (°)	-	± 5	-
Resistor (Ω)	120.5	38~23.4	16.6

D4GA engine

Temperature (°C)	50	85~105	115
Scale Angle (°)	-45	-7	25.5
Tolerance (°)	-	-3, +2	-5, +5

2. The temperature indicating range is 50~123°C.

## Tachometer

### Inspection

1. Connect the tachometer for a tune-up test, start the engine.
2. By comparing the values indicated by the tester and the tachometer, if it is over the tolerance, replace the cluster.

Except D4GA engine

STD RPM	500	1,000	2,000	3,000	3,500	4,000
Tolerance (rpm)	±50	±50	±100	±150	±150	±150

D4GA engine

STD RPM	500	1,000	1,500	2,000	2,500	3,100
Tolerance (rpm)	±30	±50	±100	±100	±150	±150

3. When performing the test of tachometer, tap the tachometer to remove the hysteresis.

## Speedometer

### Inspection

- Using the speedometer tester, check the tolerance of the speedometer.

Except D4GA engine

STD Speed (km /h)	20	40	60	80	100	120	140	160
Toler- ance	±3	+3 0	+3.5 0	+4 0	+4.5 0	+5 0	+6 0	+6 0

D4GA engine

STD Speed (km /h)	20	40	60	80	100	120	140	160
Toler- ance	+3 0	+3 0	+5 0	+5 0	+5 0	+5 0	+5 0	-

- Check that the needle of the speedometer is vibrating or the speedometer makes an abnormal noise.
- When performing the test of speedometer, tap it to remove the hysteresis.

## Door Warning Indicator

### Inspection

1. Remove the door switch(A).

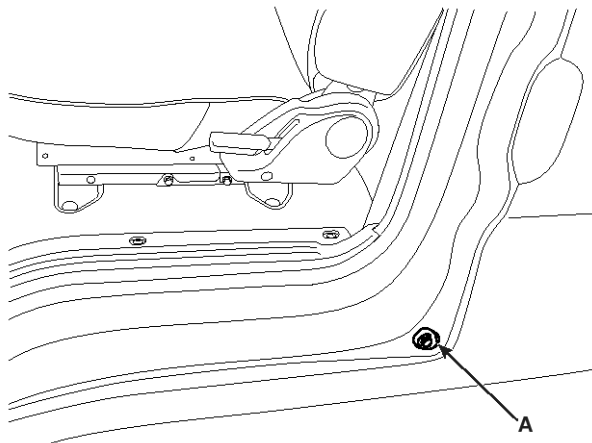

KMTBE5027A

2. Check that there is continuity between the switch's terminal and ground.

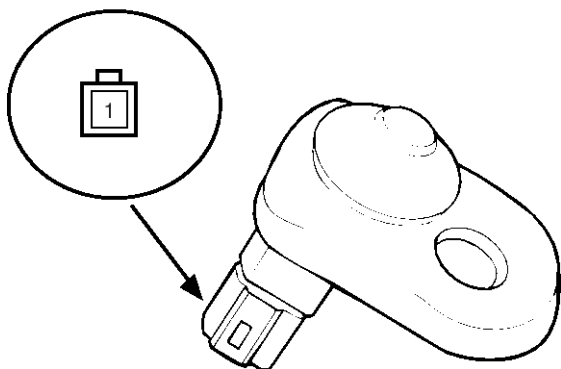

KMTBE5028A

3. If the checking value of the door switch does not satisfy the specifications, replace the door switch.

Terminal Position	Terminal	Ground
Door Open	○—○	○
Door Close		

EMTBE5018A

**Seat Belt Warning Indicator**

**Inspection**

**Inspection of seat belt switch**

1. Disconnect the seat belt switch connector (A).

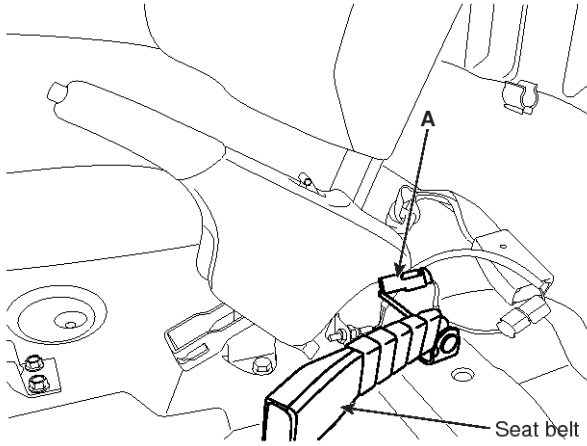

EMTBE5019A

2. Check the continuity of the door switch.

Seat Belt Condition	Fastened	Not fastened
Continuity	Non-Conductive ( $\infty \Omega$ )	Conductive (0 $\Omega$ )

**Inspection of Seat Belt Warning**

Check that the following conditions are satisfied when the ignition switch is ON.

Seat Belt Condition	Fastened	Not fastened
Warning Lamp	OFF	ON

## Parking Brake Switch

### Inspection

The parking brake is lever type. The parking brake switch (A) is installed under the parking brake lever. For adjusting that, release the parking brake, and turn the switch up and down.

1. When the switch is "ON" (when the lever is pulled), check that there is continuity between the terminal and the switch.
2. When the switch is "OFF" (when the lever is released), check that there is no continuity between the terminal and the switch. If the electricity does not satisfied the specification, replace the switch or check the ground connection.

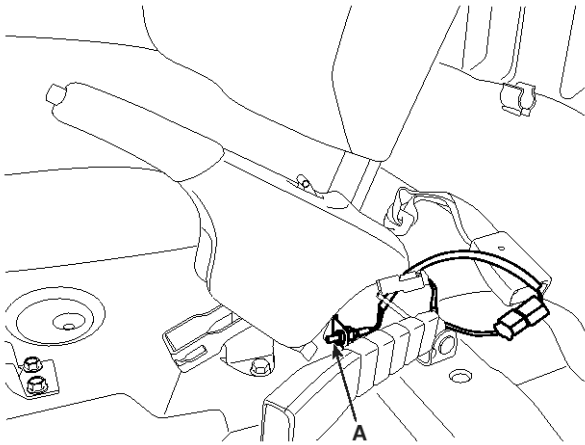

KMTBE5031A

## Tilting Lock Sensor

### Inspection

1. Remove the tilting lock sensor.

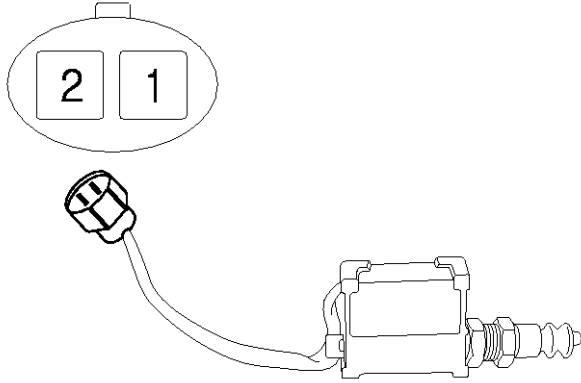

KMTBE5032A

2. Check continuity between the tilting lock sensor and the terminal. If there is no continuity, replace the tilting lock sensor.

Terminal	1	2
Position		
Cap Open	○	○
Cap Close		

EMTBE5020A



## Hazard Switch

### Inspection

1. Remove the instrument facia panel.

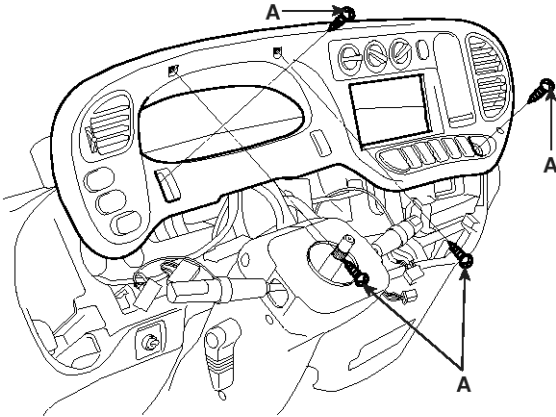

KMTBE5133A

2. Check the continuity between the terminals(A) during the hazard switch operation.

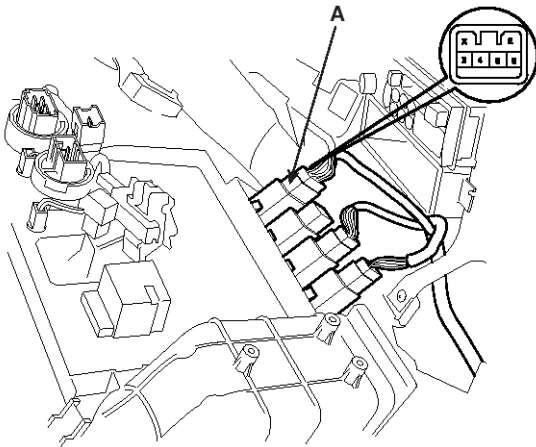

KMTBE5034A

### Circuit Diagram

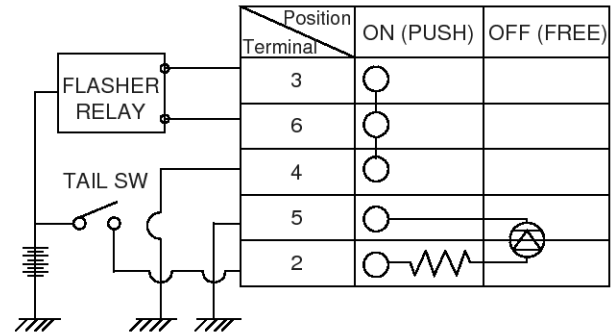

EMTBE5021A

## Working Lamp Switch

### Inspection

1. Remove the instrument facia panel mounting screw(A) and the instrument facia panel.

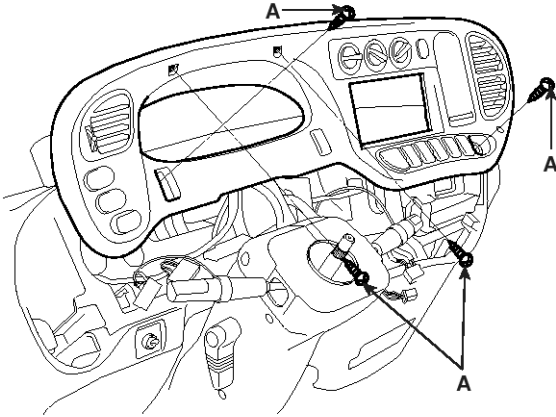

KMTBE5133A

2. Remove the working lamp switch(A).

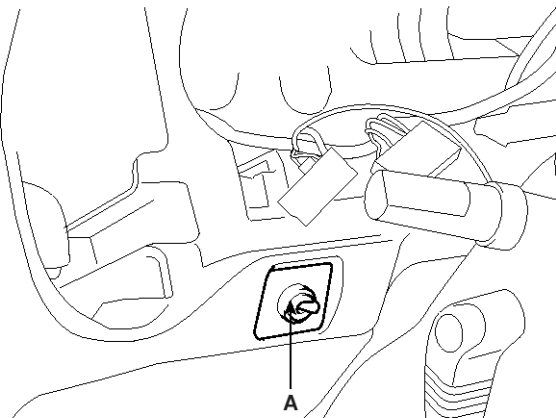

KMTBE5134A

3. Check continuity between the terminals during the switch operation.

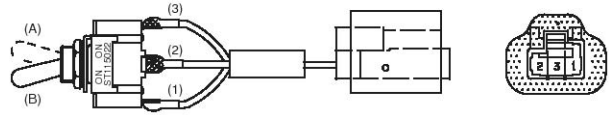

KMTBE5036A

Terminal / Position	1	2	3
ON	○	○	
OFF		○	○

SUDBEA0039L

## Front/Rear Fog Lamp Switch

### Inspection

1. Remove the instrument facia panel mounting screw(A) and the instrument facia panel.

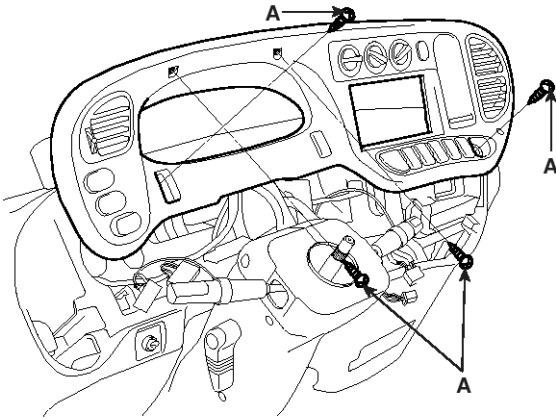

KMTBE5133A

2. Check continuity between the terminals during operating the switch.

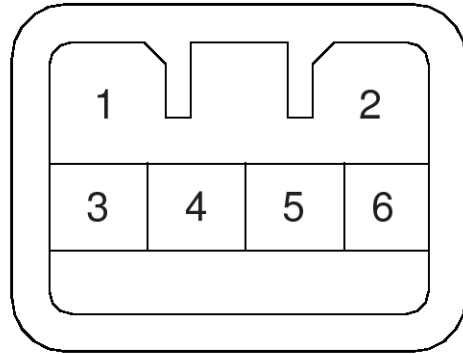

KMTBE5040A

Position Terminal	ON(PUSH)	OFF(FREE)	
5			
4			LOAD
1			IND +
3			IND -
2			ILL +
6			ILL -

EMTBE5024A

## Idle Adjust Switch

### Inspection

1. Remove the instrument facia panel mounting screw(A) and the instrument facia panel.

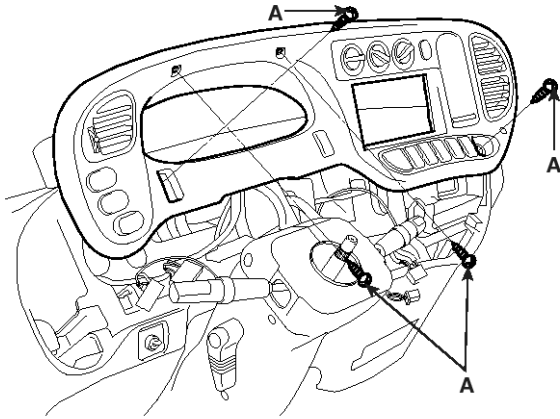

SUDBEA0005L

2. Check continuity between the terminals during operating the switch.

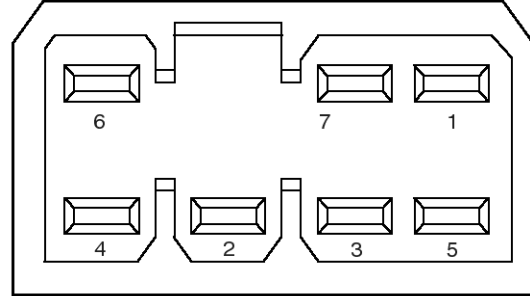

SUDBEA0006L

		I (UP)	N (OFF)	I (DOWN)	
Switch	1	○		○	
	2			○	
	3	○			
Illumination	4				
	5				
	6		○		
	7	○	○		Night illumination

SUDBEA0007L

## Multi Function Switch

### Components

[LHD]

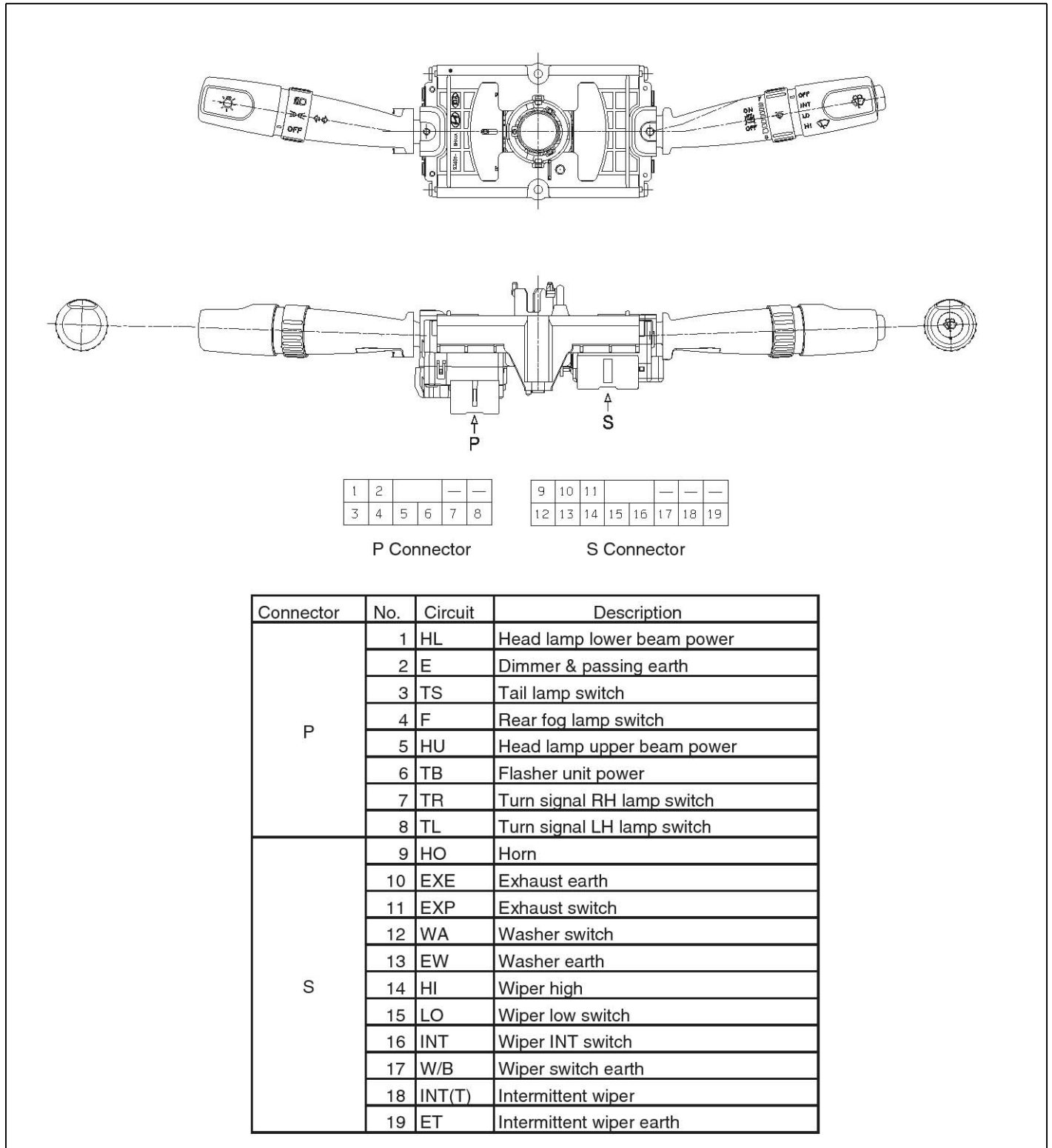

[RHD]

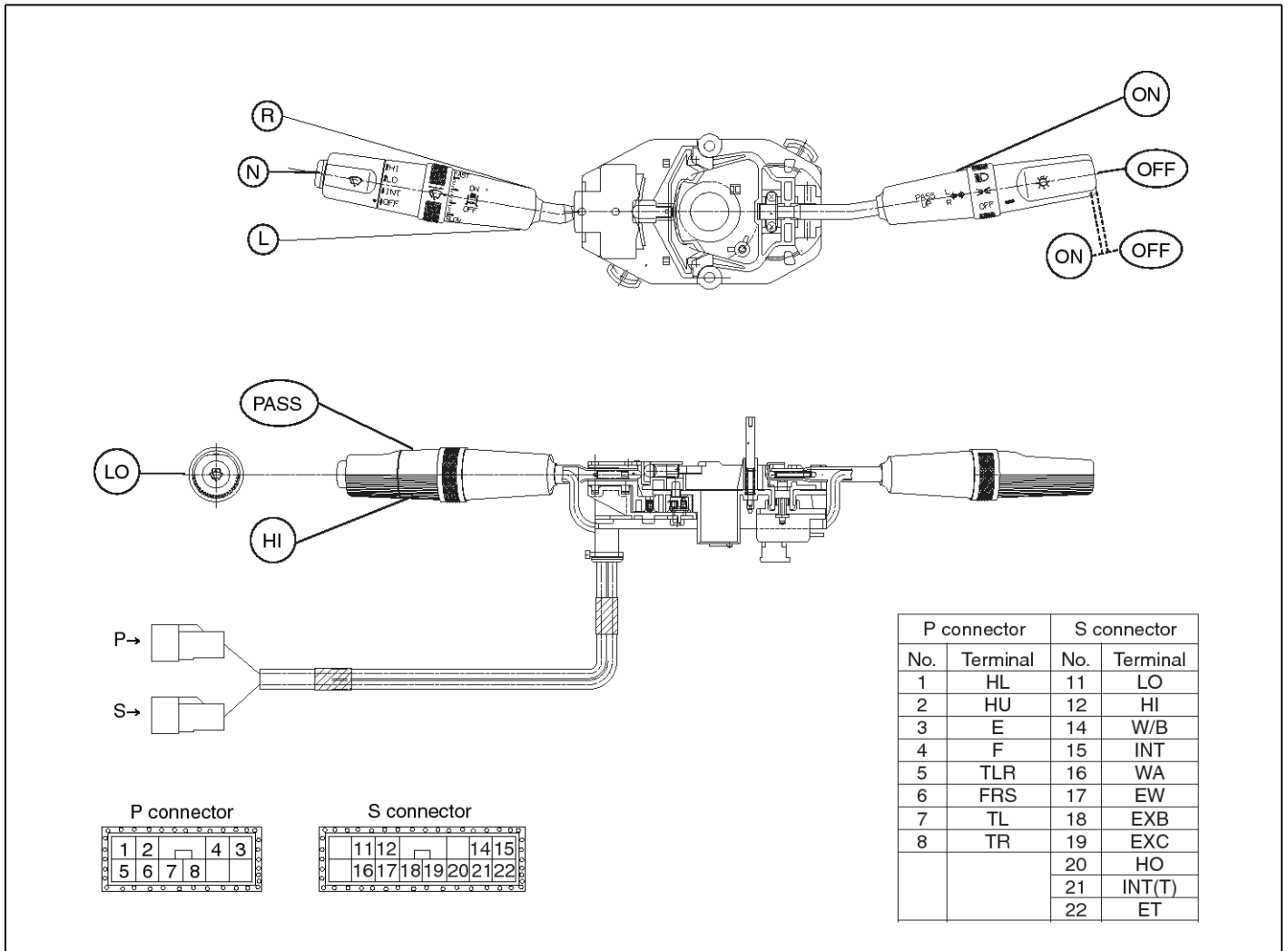

SUDBEA0009L

## Inspection

### LHD type

With operating the switch, check continuity between terminals.

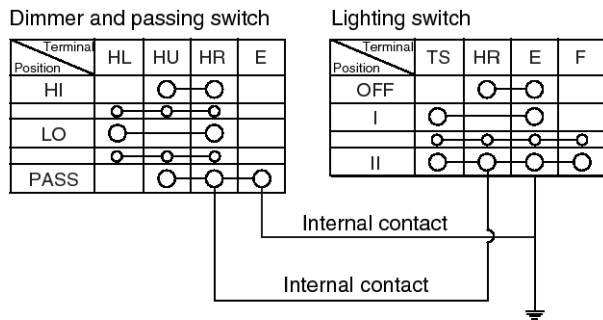

SUDBEA0010L

### Turn signal lamp switch

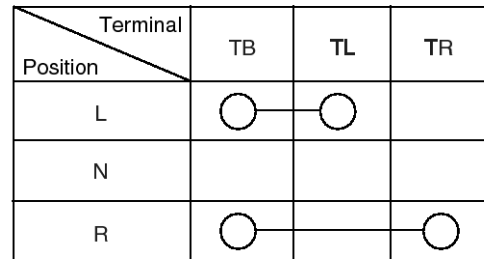

SUDBEA0011L

### Wiper & washer & intermittent time switch

P	T	HI	LO	INT	W/B	WA	EW	Et	INT(T)
OFF						○—○			
INT				○—○		○—○	○—○	○—○	○—○
LOW			○—○		○—○	○—○	○—○		
HI		○—○			○—○	○—○	○—○		

### Wiper & washer & intermittent time switch(Optional)

P	T	HI	LO	INT	W/B	WA	EW	Et	INT(T)
OFF						○—○			
INT						○—○	○—○		
LOW			○—○		○—○	○—○	○—○		
HI		○—○			○—○	○—○	○—○		

SUDBEA0012L

### Exhaust brake switch

Terminal Position	EXP	EXE
OFF		
ON	○—○	○—○

SUDBEA0013L

### Ignition key switch

Terminal Position	B1	ACC	M1	B2	M2	S
Locked						
ACC	○—○					
ON	○—○	○—○	○—○	○—○	○—○	
START	○—○		○—○	○—○	○—○	○—○

### Heating mirror

Switch	1	2	3	4	5	6	7
	○	○	○	○	○	○	○
				Operating lighting at ON			
Lighting							
							Night lighting

SUDBEA0014L

### RHD type

#### Dimmer & passing switch

P	T	HL	HU	HR	E
HI		○—○	○—○	○—○	
LO		○—○	○—○	○—○	
PASS		○—○	○—○	○—○	

#### Light switch

P	T	TLR	HR	E	F
OFF					
I		○—○	○—○	○—○	○—○
II		○—○	○—○	○—○	○—○

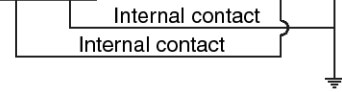

SUDBEA0015L

#### Turn signal switch

P	T	FRS	TL	TR
L		○—○	○—○	
N				
R		○—○		○—○

SUDBEA0016L

#### Wiper & washer switch

P	T	LO	HI	W/B	INT	WA	EW
OFF					○—○	○—○	○—○
INT					○—○	○—○	○—○
LOW		○—○		○—○		○—○	○—○
HI		○—○	○—○	○—○		○—○	○—○

SUDBEA0017L

#### Wiper & washer switch(Optional)

P	T	LO	HI	W/B	INT	WA	EW
OFF						○—○	○—○
LOW		○—○		○—○		○—○	○—○
HI		○—○	○—○	○—○		○—○	○—○

SUDBEA0018L

#### Exhaust brake switch

P	T	EXB	EXC
OFF			
ON		○—○	○—○

SUDBEA0019L

#### Timer variable switch

P	T	INT(T)	ET
INT		○—○	○—○

SUDBEA0020L

## Windshield Wiper / Washer

## Component Location

The parts with asterisk(\*) :  
This illustration shows the LHD type.  
RHD type is symmetrical.

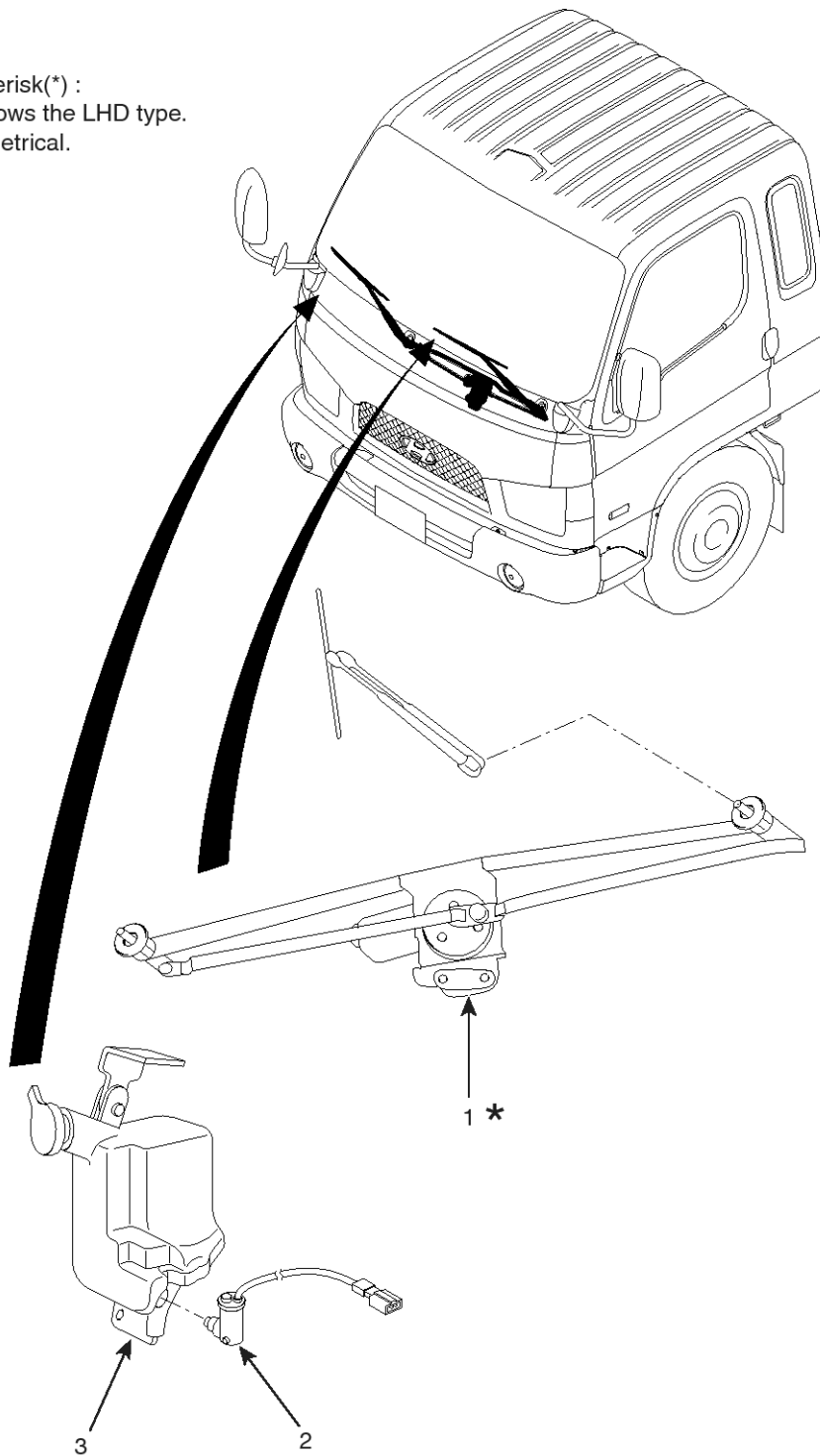

SUDBEA0021L

1. Wiper link
2. Washer motor

3. Washer reservoir



## Windshield Wiper / Washer

### Removal

1. Take off the battery (-) cable(A).

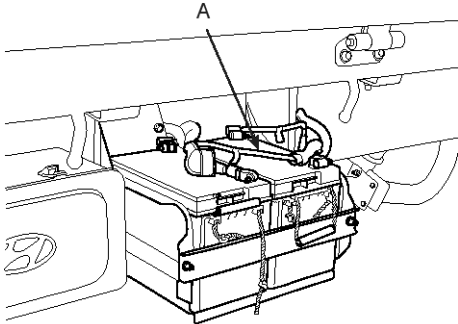

SUDBEA0040L

2. Remove the wiper arm cap(A).  
After loosening the wiper arm mounting nut(B),  
remove the washer hose(C).  
Remove the window shield wiper arm(D) and blade.

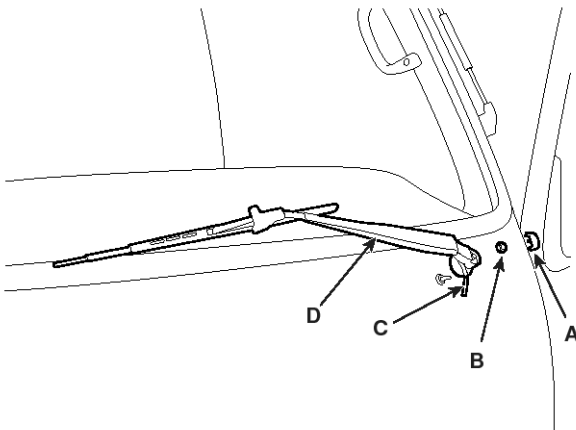

KMTBE5050A

3. After taking off the cover (A), loosen the nut (B) and  
remove the cap and pad (C).

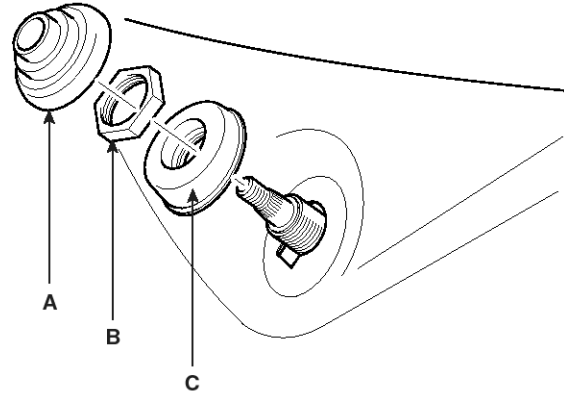

KMTBE5051A

4. Remove the crash pad assembly. (Refer to the  
"Crash Pad of the BD group")
5. After taking off the wiper motor (A) tightening bolt,  
remove the wiper motor assembly and the wiper  
linkage assembly(B).

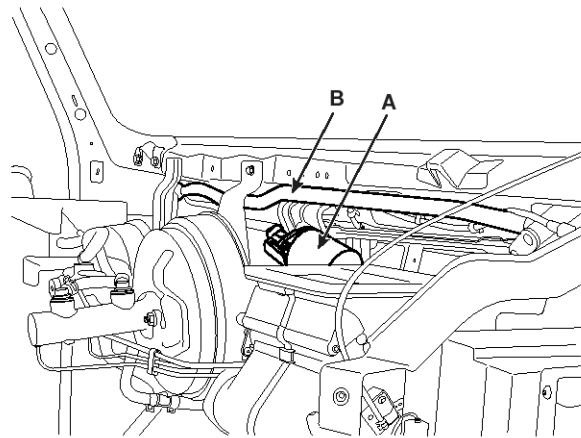

KMTBE5052A

# BE-42

# Body Electrical System

6. Remove the washer motor(B) from the washer reservoir(A).

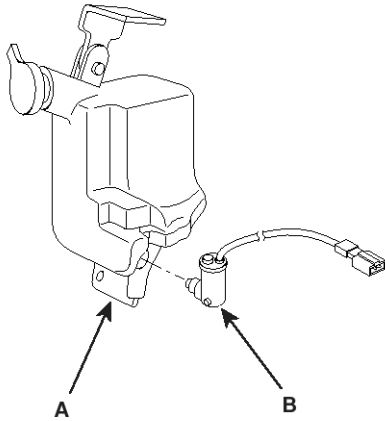

KMTBE5147A

7. The installation is performed in the reverse order of the removal.

## Inspection

### Washer Motor

1. After disconnect the washer motor connector (A) and the check valve (B), connect the battery to the washer motor connector.

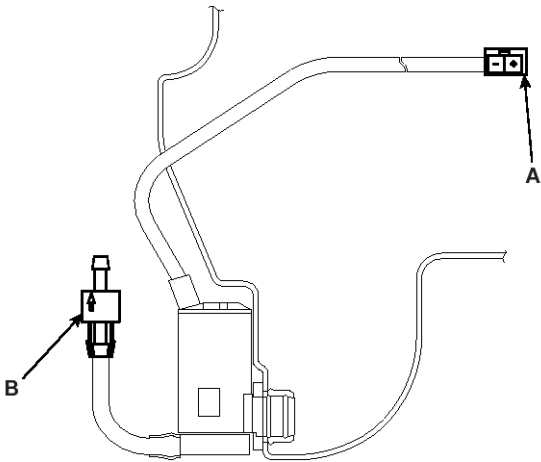

KMTBE5055A

2. If the washer liquid is flown out to the check valve by the operation of the washer motor, it is normal. Otherwise, replace the washer motor.

## Circuit Diagram

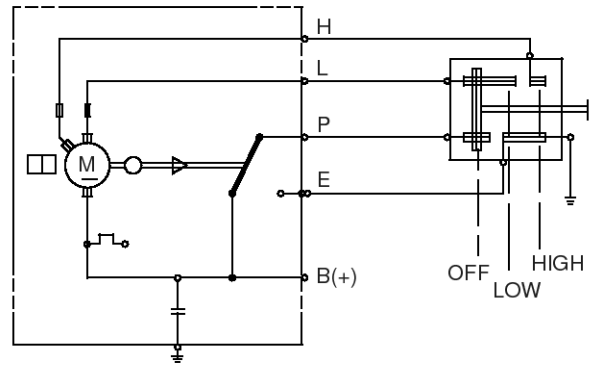

KMTBE5053A

## Connector Configurations

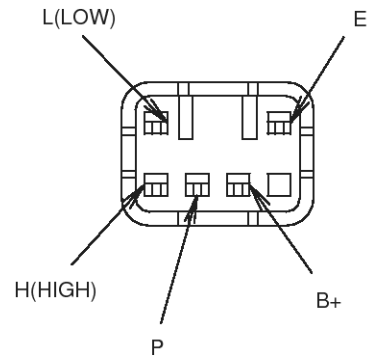

KMTBE5054A

## Power Windows

### Power Window Motor

#### Connector Configurations

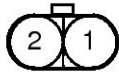

KMTBE5063A

#### Circuit Diagram

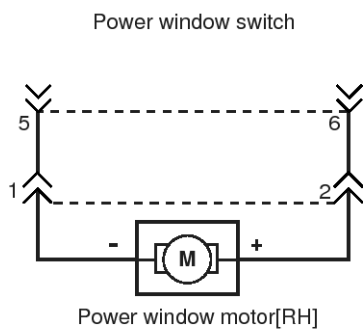

EMTBE5038A

#### Inspection

Connect the battery and then check that the power window motor is working.

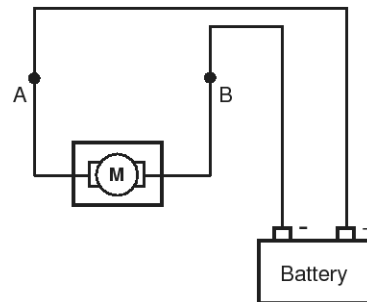

EMTBE5039A

	A	B	Rotational Direction
LH	-	+	CCW
	+	-	CW
RH	-	+	CW
	+	-	CCW

CCW : Counterclockwise

CW : Clockwise

#### **NOTICE**

*The rotational direction of the motor is referred to the output axis of the motor.*

## Power Window Switch

### Inspection

Check the continuity of switch using multi tester. If needed, replace it.

### [Main switch]

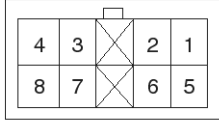

SUDBEA0041L

Power window main switch

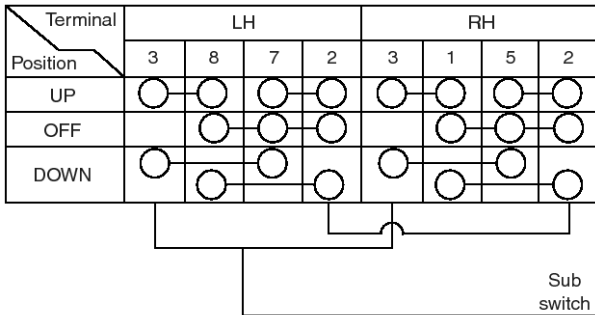

Connecting circuit

SUDBEA0042L

### [Sub switch]

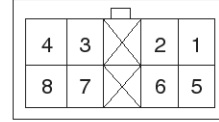

SUDBEA0041L

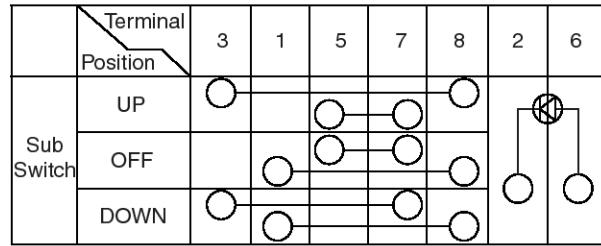

Connecting circuit

SUDBEA0043L

## Circuit Diagram [Main Switch]

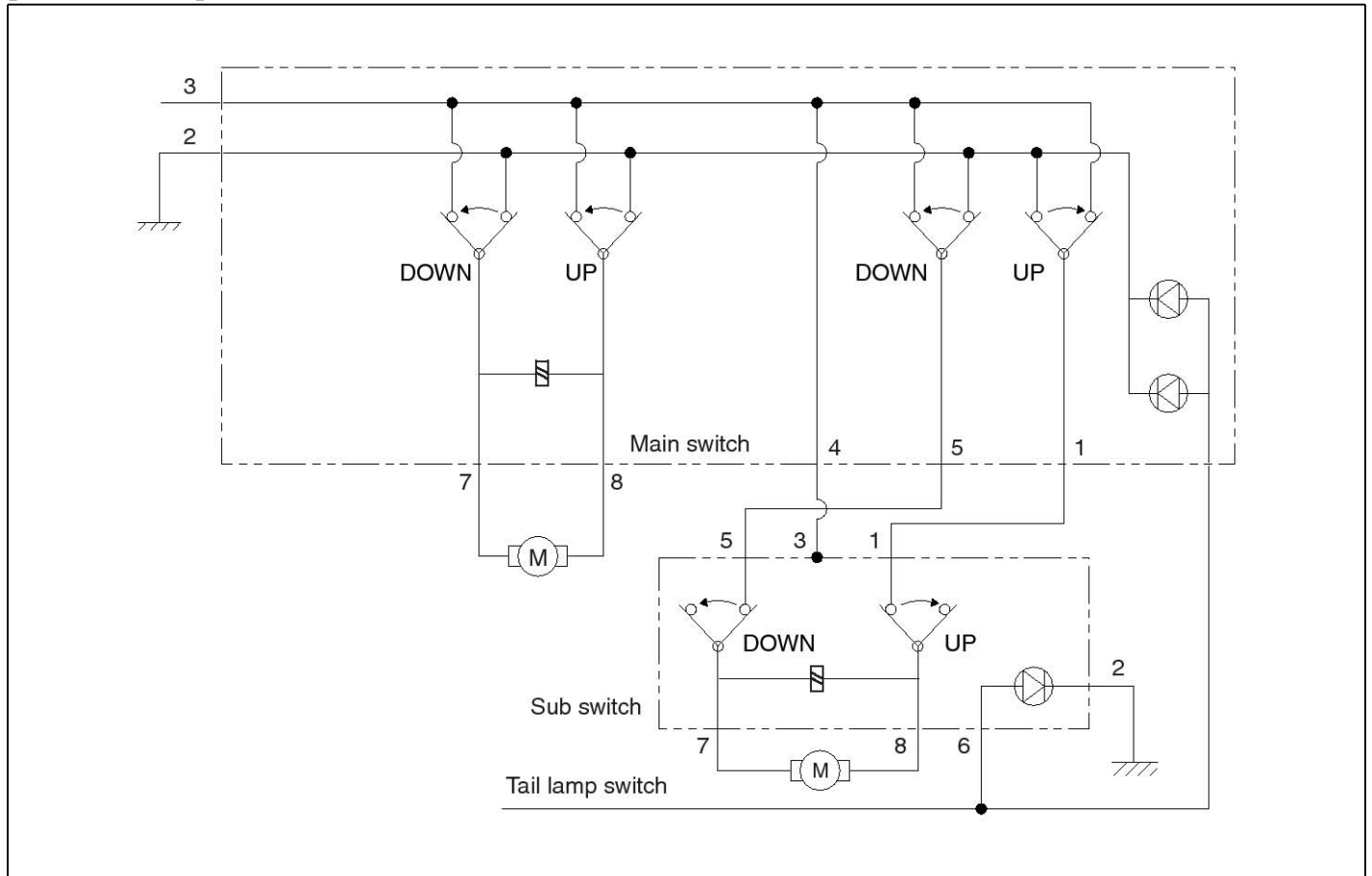

SUDBEA0044L

## [Sub Switch]

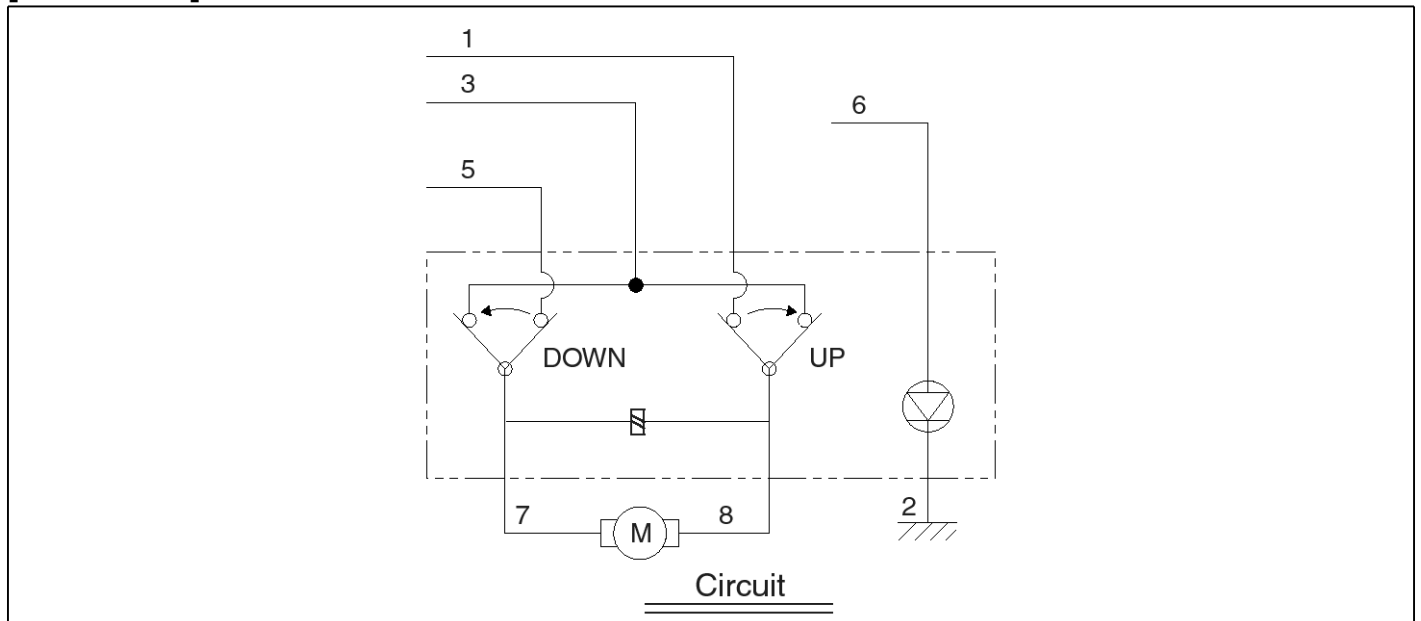

SUDBEA0045L

Lighting System

Components

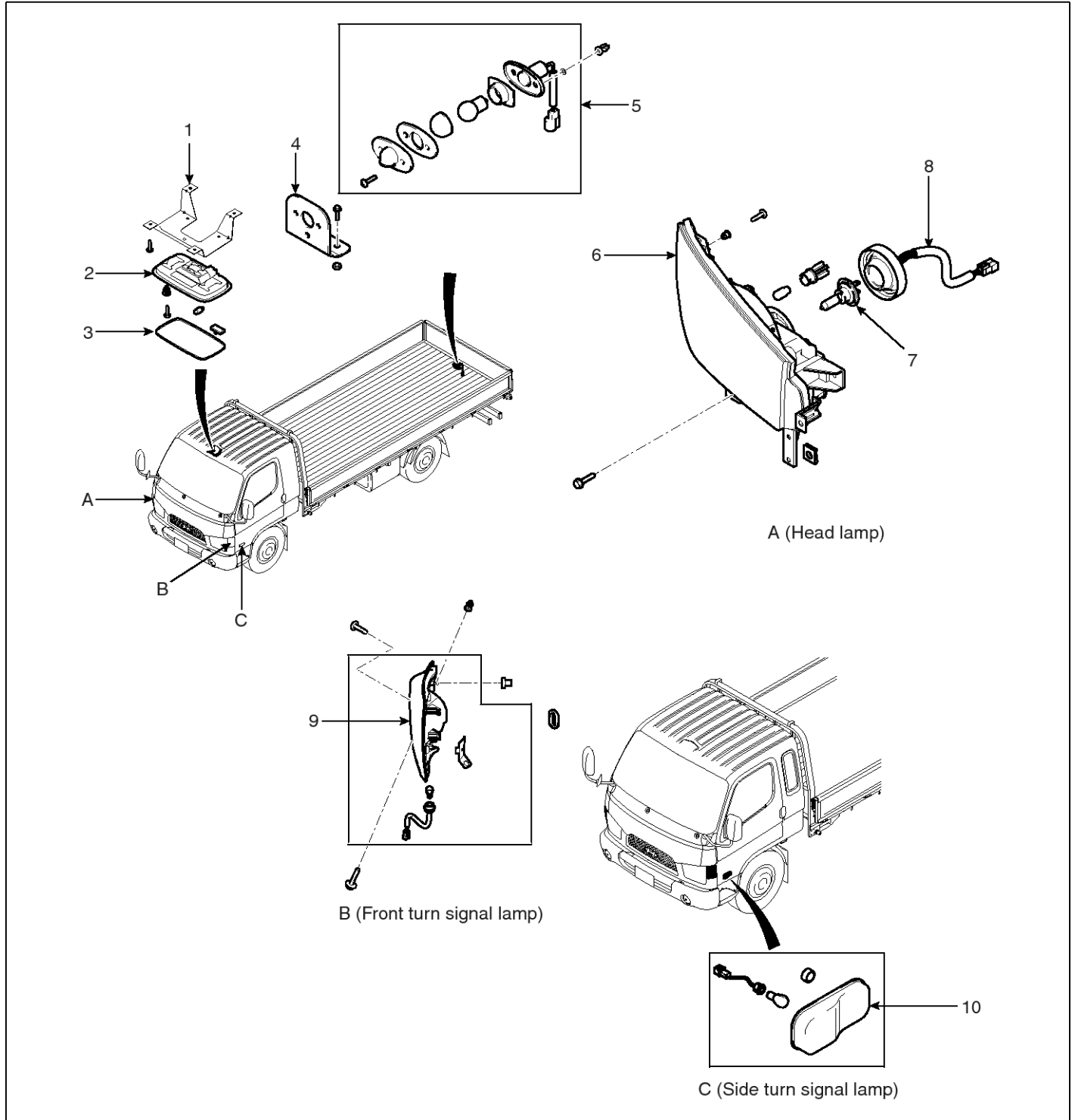

SUDBEA0052L

- 1.Room lamp mounting bracket
- 2.Body assembly
- 3.Room lamp lens

- 4.License plate mounting bracket
- 5.License plate lamp assembly
- 6.Head lamp

- 7.Bulb
- 8.Head lamp wiring assembly
- 9.Front turn signal lamp
- 10.Side turn signal lamp

## Head Lamp

### Replacement

1. Take off the battery (-) terminal.

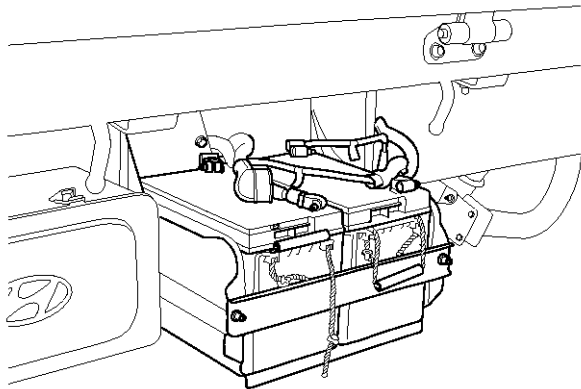

KMTBE5065A

2. Take off the connectors (A) of the both fog lamps.

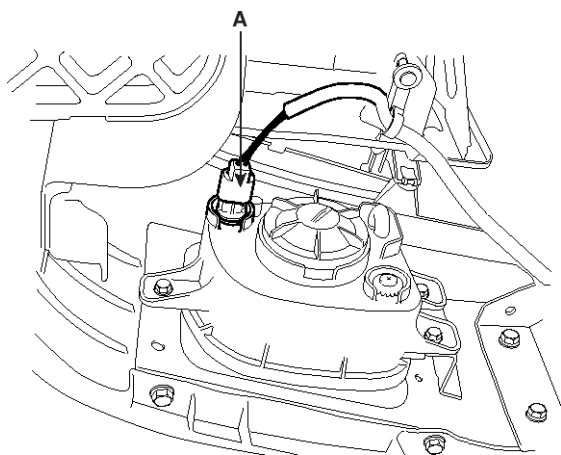

KMTBE5066A

3. After taking off the bolt (A), remove the bumper (B).

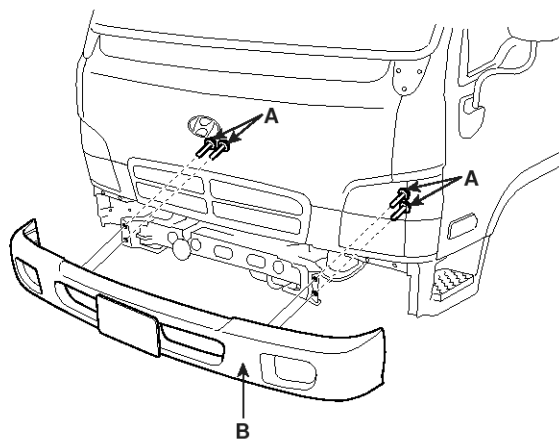

KMTBE5067A

4. Remove the front grill (A).

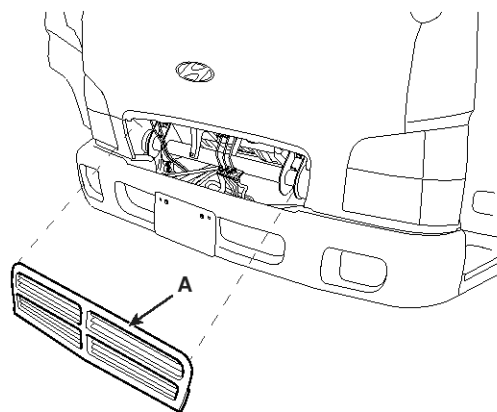

KMTBE5068A

- Remove the front garnish (A) and the combination lamp (B).

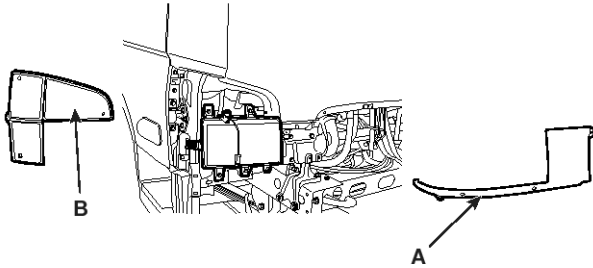

KMTBE5069A

- Remove the head lamp (A).

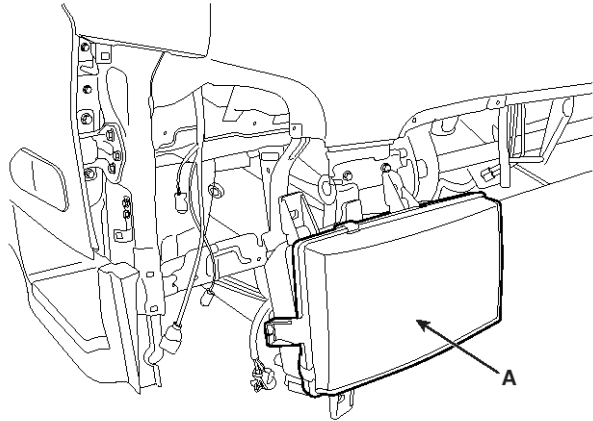

KMTBE5070A

- The installation is performed in the reverse order of the removal.

## Inspection

- Setup the tire pressure to the specifications, park the vehicle on the even ground. Do not tilt the vehicle.
- Do not apply any additional load except for the driver.
- Check that the leaf spring and the shock absorber is damaged.
- Set a screen at 3m from the head lamp.

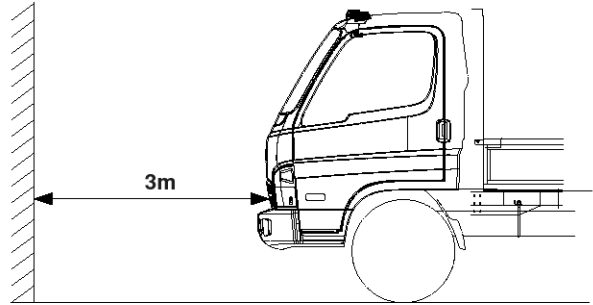

KMTBE5072B

- Check that the width(H1) between the head lamp satisfies the specifications.

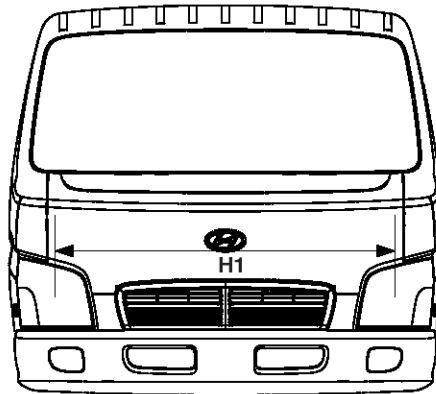

EMTBE5057A

Model	H1(mm)
HD65	1240
HD72, HD78	1240

## NOTICE

H1: Width between the head lamps



6. Check that the height(H2) of the lamp from the ground satisfies the specifications.

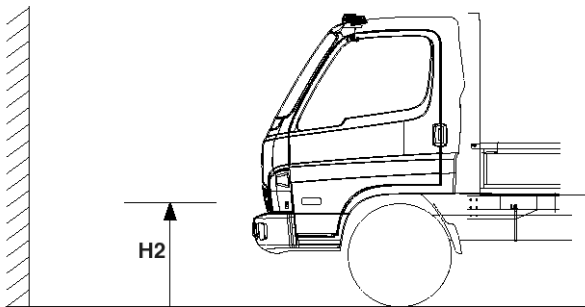

EMTBE5058A

Model	H2(mm)
HD65	760
HD72, HD78	790

**CAUTION**

The tolerance of the height tolerance should be within  $\pm 30$ mm.

**NOTICE**

H2: Height of the head lamp from the ground

7. With lightening the head lamp (low), adjust the CUT-OFF line to be within the permission range.

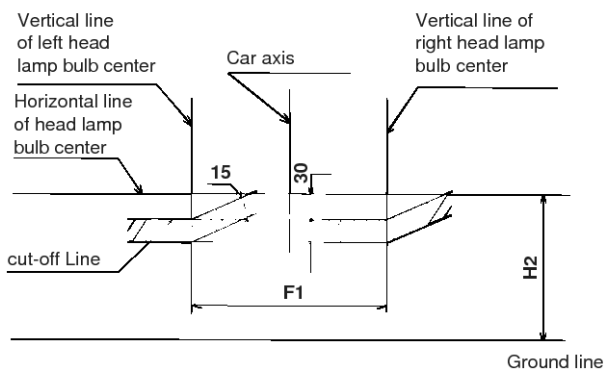

EMTBE5040A

8. With lightening the head lamp (high), adjust the HOT-ZONE to be within the permission range.

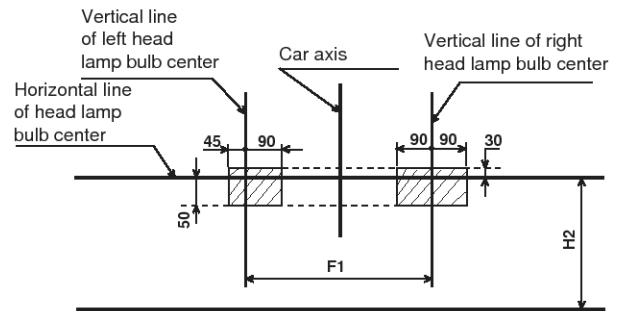

EMTBE5041A

## Adjustment

1. Setup the tire pressure to the specifications, park the vehicle on the even ground. Do not tilt the vehicle.
2. Do not apply any additional load except for the driver.
3. Check that the leaf spring or the shock absorber is damaged.
4. Set a screen at 3m from the head lamp.

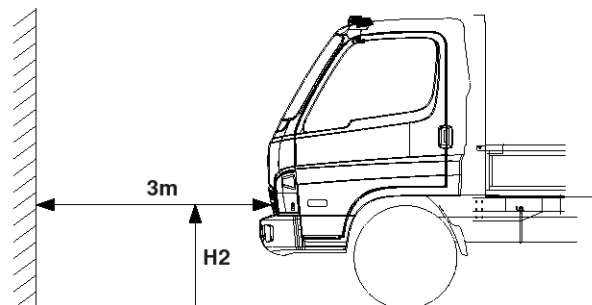

KMTBE5140A

# BE-50

# Body Electrical System

5. Check that the width between the head lamp satisfies the specifications.

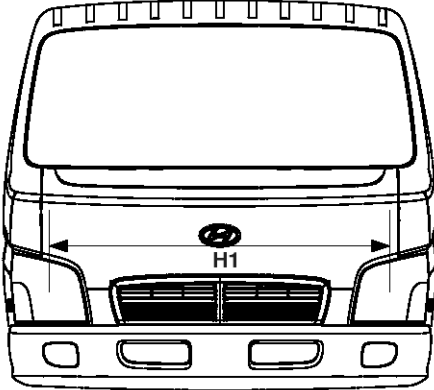

EMTBE5057A

Model	H1(mm)	H2(mm)
HD65	1240	760
HD72, HD78	1240	790

**⚠ CAUTION**

The tolerance of the height tolerance should be within  $\pm 30\text{mm}$ .

**📌 NOTICE**

*H1: Width between the head lamps*

*H2: Height of the head lamp from the ground*

6. Adjust by turning the adjusting hole (A) to clockwise direction or counter clockwise direction using a + driver.

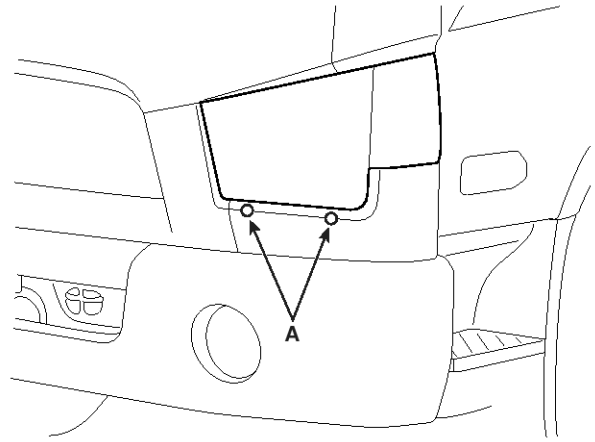

KMTBE5077A

## Turn Signal Lamp

### Replacement

1. Remove the battery (-) terminal.

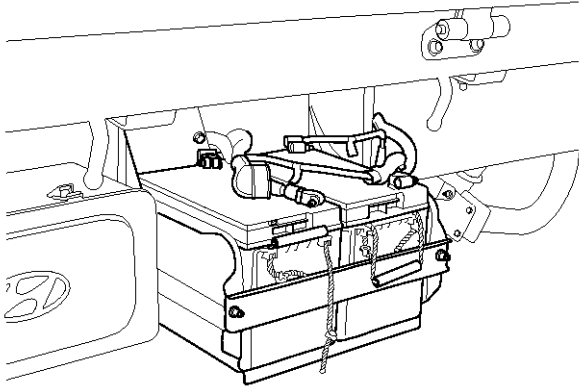

KMTBE5065A

2. Remove the combination lamp (A).

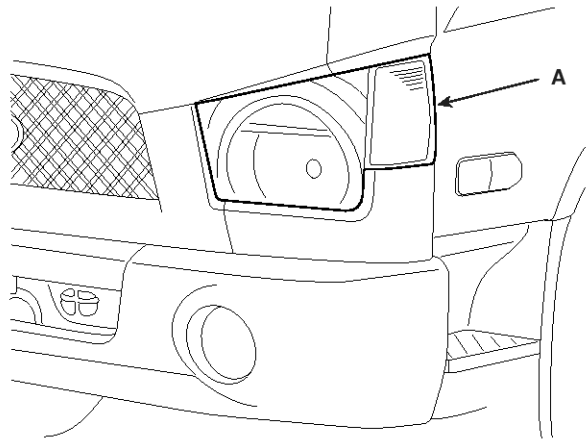

KMTBE5078A

## Room Lamp

### Replacement

1. Take off the battery (-) terminal.

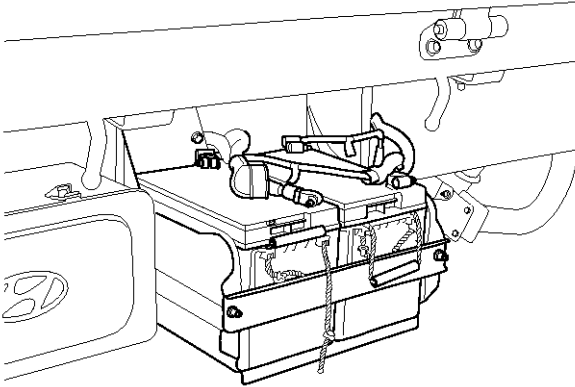

KMTBE5065A

2. After removing the room lamp lens (A), remove the fixing screw.

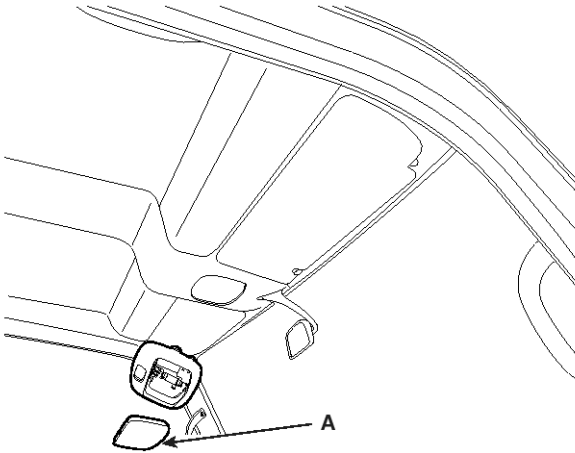

KMTBE5079A

3. After disconnecting the room lamp connector(B), remove the room lamp (A).

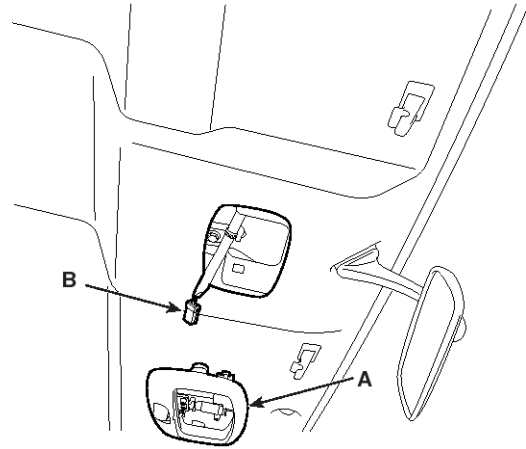

KMTBE5080A

## Fog Lamp

### Replacement

1. Take off the battery (-) terminal.

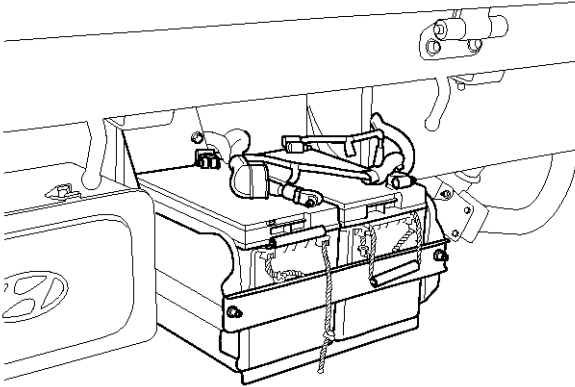

KMTBE5065A

2. After disconnecting the fog lamp connector (A) and the fixing bolt (B), remove the fog lamp (C).

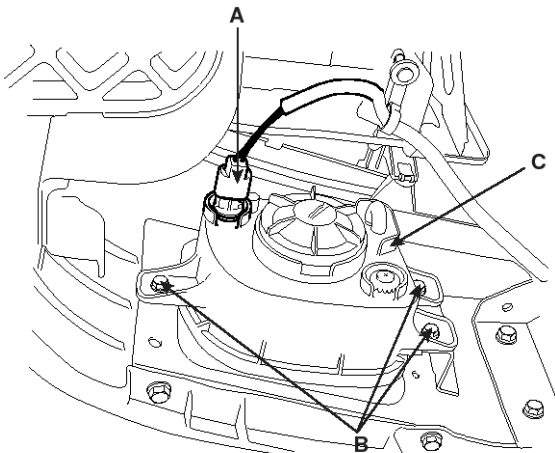

KMTBE5081A

### Inspection

1. Setup the tire pressure to the specifications, park the vehicle on the even ground. Do not tilt the vehicle.
2. Do not apply any additional load except for the driver.
3. Check that the leaf spring or the shock absorber is damaged.
4. Set a screen at 3m from the fog lamp.

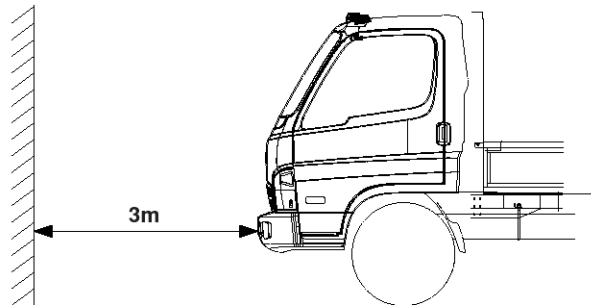

KMTBE5141A

5. Check that the width(A) between the fog lamp satisfies the specifications.

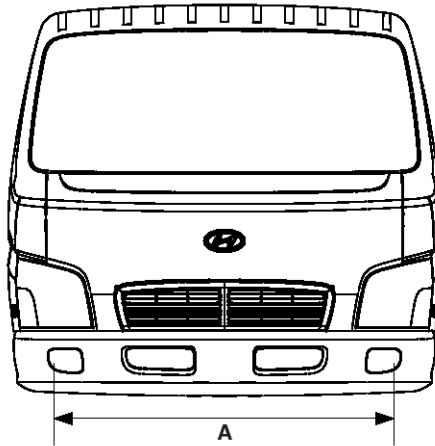

SUDBEA0046L

Model	A(mm)
HD65	1150
HD72, HD78	1150

# BE-54

# Body Electrical System

- Check that the height(A) of the lamp from the ground satisfies the specifications.

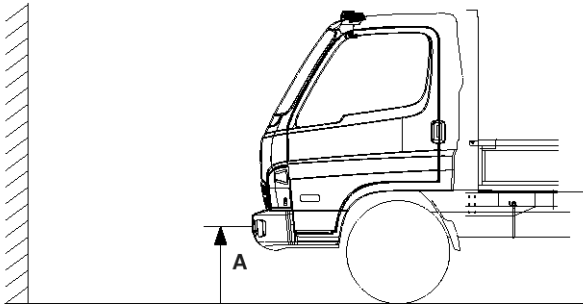

KMTBE5143A

Model	A(mm)
HD65	535
HD72, HD78	555

**CAUTION**

The tolerance of the height tolerance should be within  $\pm 30\text{mm}$ .

**NOTICE**

A : Height of the head lamp from the ground

- With lightening the fog lamp, adjust the CUT-OFF line to be within the permission range.

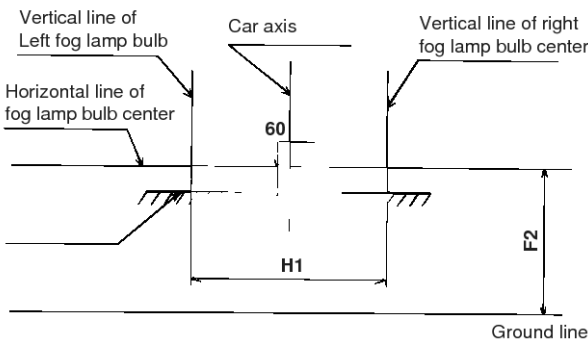

EMTBE5042A

## Adjustment

- Setup the tire pressure to the specifications, park the vehicle on the even ground. Do not tilt the vehicle.
- Do not apply any additional load except for the driver.
- Check that the leaf spring or the shock absorber is damaged.
- Set a screen at 3m from the fog lamp.

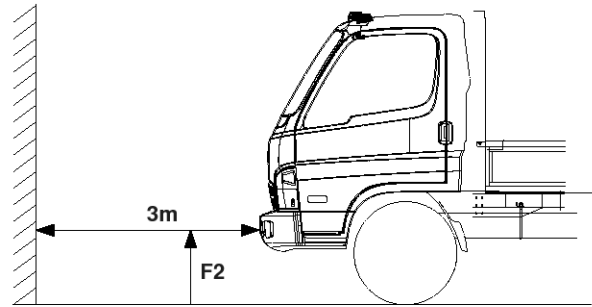

KMTBE5144A

- Check that the width between the fog lamp satisfies the specifications.

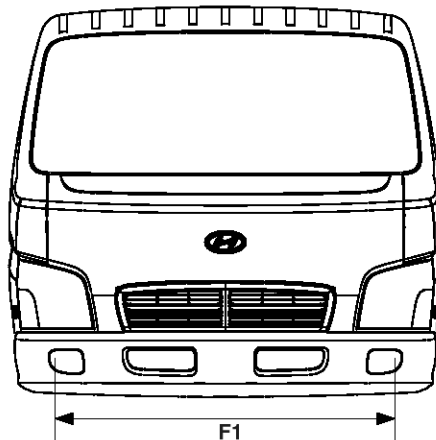

SUDBEA0047L

Model	F1(mm)	F2(mm)
HD65	1150	535
HD72, HD78	1150	555

**CAUTION**

The tolerance of the height tolerance should be within  $\pm 30\text{mm}$ .

**NOTICE**

F1: Width between the fog lamps

F2: Height of the fog lamp from the ground

- Adjust by turning the adjusting screw(A) to clockwise direction or counter clockwise direction using a + driver.

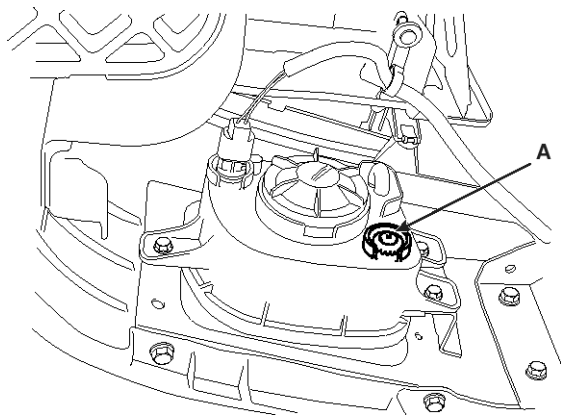

KMTBE5083A

## Head Lamp Leveling Device

### Description

According to driving environment and loading state of vehicle, head lamp lighting direction is changed to keep the driver's visibility range and to protect the driver's vision from glare, aiming at safety driving.

If needed, a driver can change the height of head lamp lighting with operating the head lamp leveling device switch.

### Components

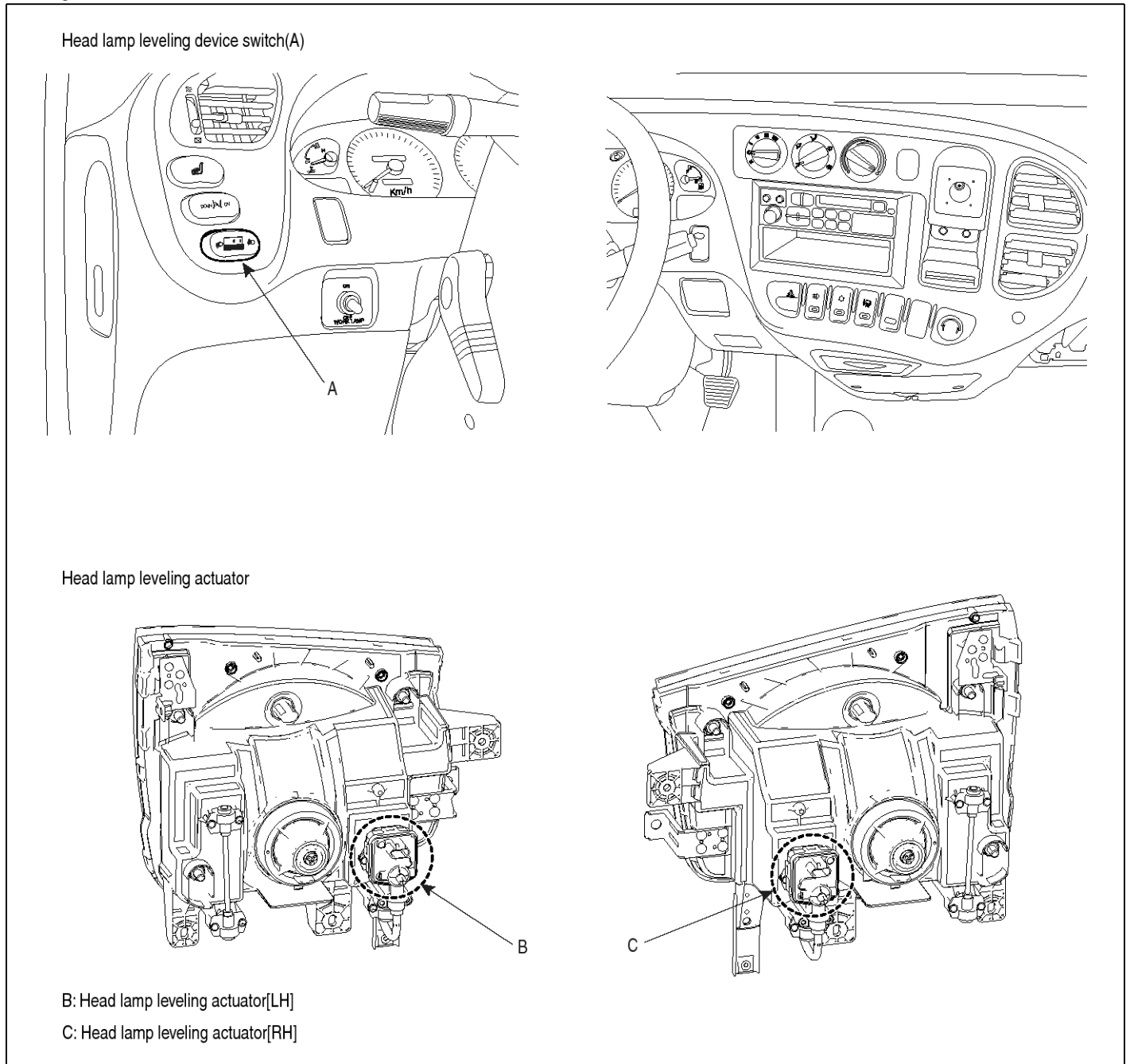



## Part circuit diagrams

### Head lamp leveling switch

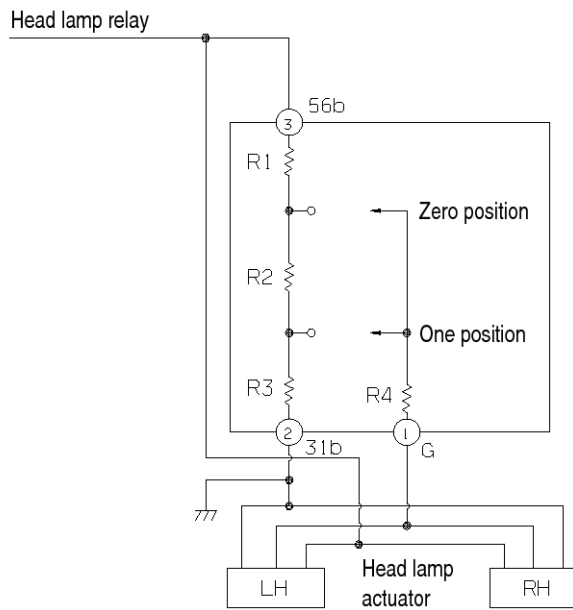

R1=1000ohm, R2=300ohm, R3=3600ohm, R4=390ohm

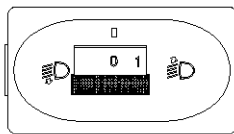

[Front side]

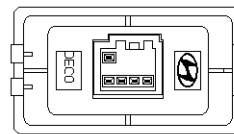

[Rear side]

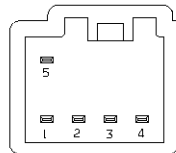

- 1 : ACT(+)
- 2 : E
- 3 : IGN
- 4 : -
- 5 : -

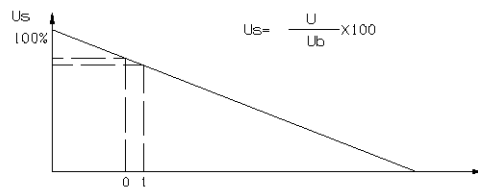

U<sub>b</sub> : Voltage between 56b - 31b

U : Voltage between G - 31b

No	Position	U <sub>s</sub> (±5%)	Rotation angle	U (±1.2V)
0	0	80	0°	22.4
1	1	73.5	30°	20.58

## Head lamp leveling actuator

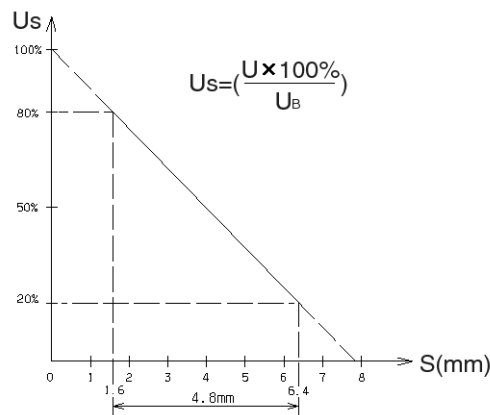
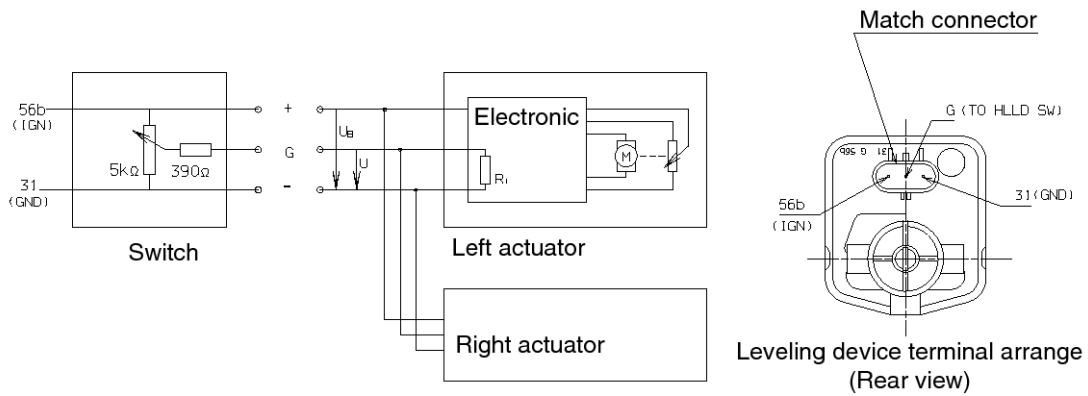

ADJUSTING LENGTH : Adjusting length  
 Slope of characteristic curve 12.5 %/mm  
 Warranted stroke : 80-20 %(4.8 mm)

\* HLLD : Head lamp leveling device

## Keyless Entry System

### Components

### ETACS

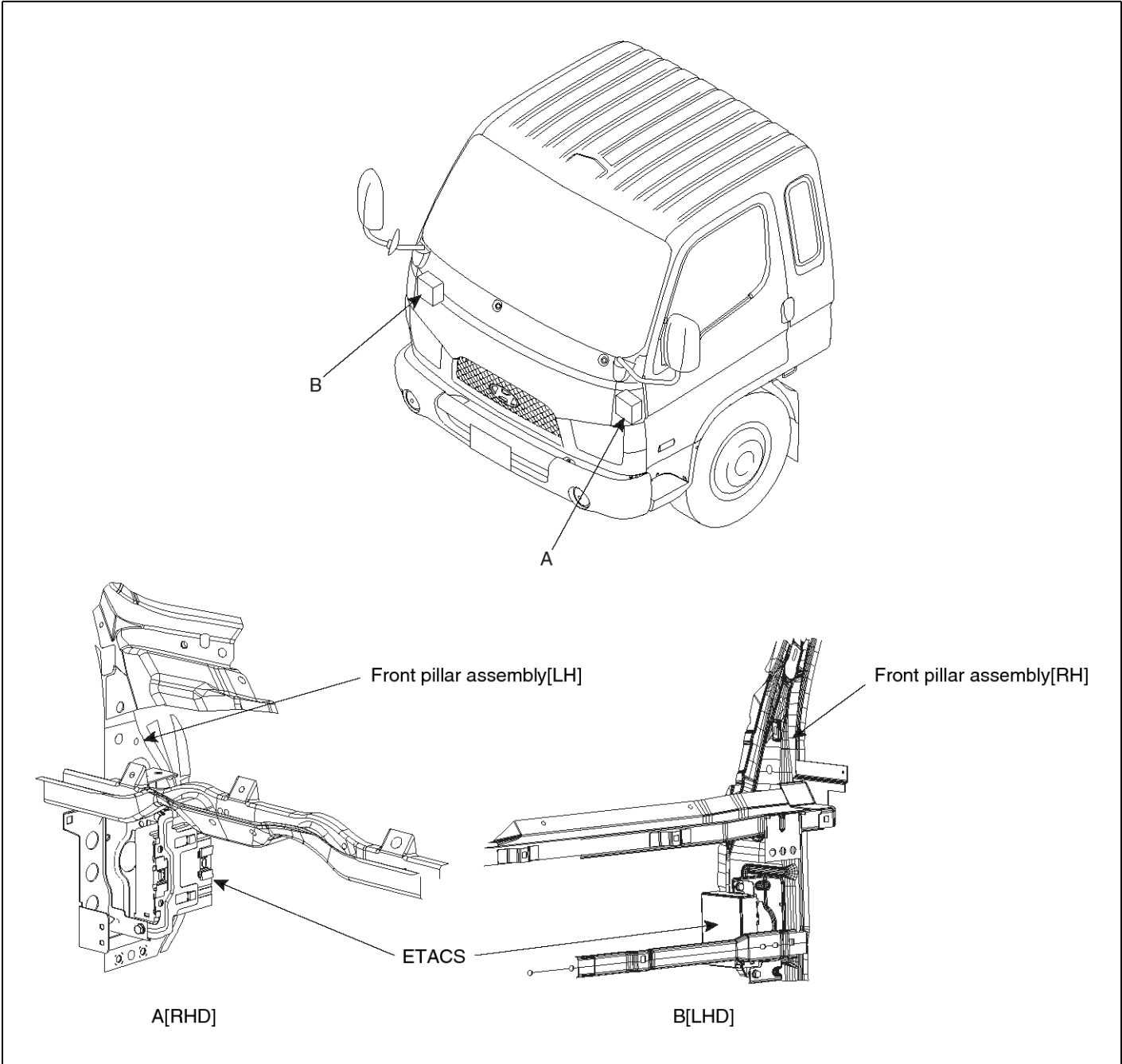

Transmitter assembly

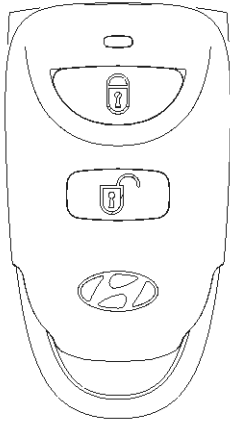

SUDBEA0030L

Burglar alarm horn assembly

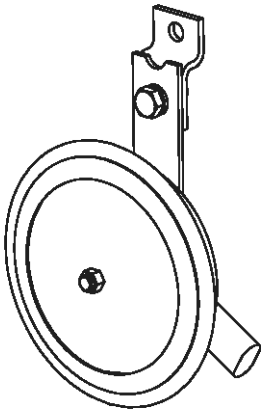

SUDBEA0031L

## DESCRIPTION

The burglar alarm system is armed automatically after the doors are closed and locked by transmitter.

The alarm activates when any of these things occurs :

- A door is forced open.
- A door is unlocked without using the transmitter.
- The cap is tilted.

### Armed stage

The system is applied when the doors are locked by using the transmitter.

The turn signal lamp blinks twice at the moment that the system is on and blinks once when the system is off.

The warning system is not released even though the battery is reconnected after disconnected at the stage that the system is on.

### Disarmed stage

The system is released only when the "UNLOCK" button on the transmitter is pressed.

When the door is unlocked with a key instead of the transmitter, the siren sounds immediately.

If the key is turned to the "ACC ON" position within 15 seconds, the system is released after 30 seconds.

## KEYLESS ENTRY SYSTEM

The burglar alarm system is integrated with the keyless entry system.

The keyless entry system allows you to lock and unlock the vehicle with the remote transmitter.

When you push the LOCK button, all doors lock. When you push the UNLOCK button, all doors unlock.

If you do not open a door, the light will go off in about 30 seconds, the doors will automatically relock, and the burglar alarm system will rearm.

You cannot lock or unlock the doors with the remote transmitter if the key is in the ignition switch.

The system will signal you when the doors lock and unlock, by flashing the hazard lamp once when they lock, and twice when they unlock.

## Operation

### 1. Keyless entry

#### 1) Security code memory

##### 1. Memory method by CODE SAVING mode entry

Entering the CODE SAVING mode, write the beginning code(ID CODE, 66 bits Rolling Code) transmitted by transmitter to EEPROM .

But, every time the Rolling Code is received, it has to be changed.

### 2. CODE SAVING conditions

1) When KEY is ACC OFF and TX REGISTER switch is ON(GND)

2) In other way, after ACC is to do ON/OFF three times within 10 seconds, TAIL switch is ON/OFF three times. (Operation of ACC and TAIL switch must start on OFF state.)

If there is no the TX signal within 5 seconds just after entering the CODE SAVING MODE, this MODE will be canceled (At memorizing two codes, do the TIMER RESET after memorizing first code.)

- Disregard the RKE signal in the CODE SAVING mode.(Not operated LOCK/UNLOCK)

- The HAZARD lamp is ON in the CODE SAVING MODE, it will be turned OFF/ON when transmitter code is saved.(OFF TIME:T1)

- Turn OFF the HAZARD lamp when the CODE SAVING MODE is canceled.

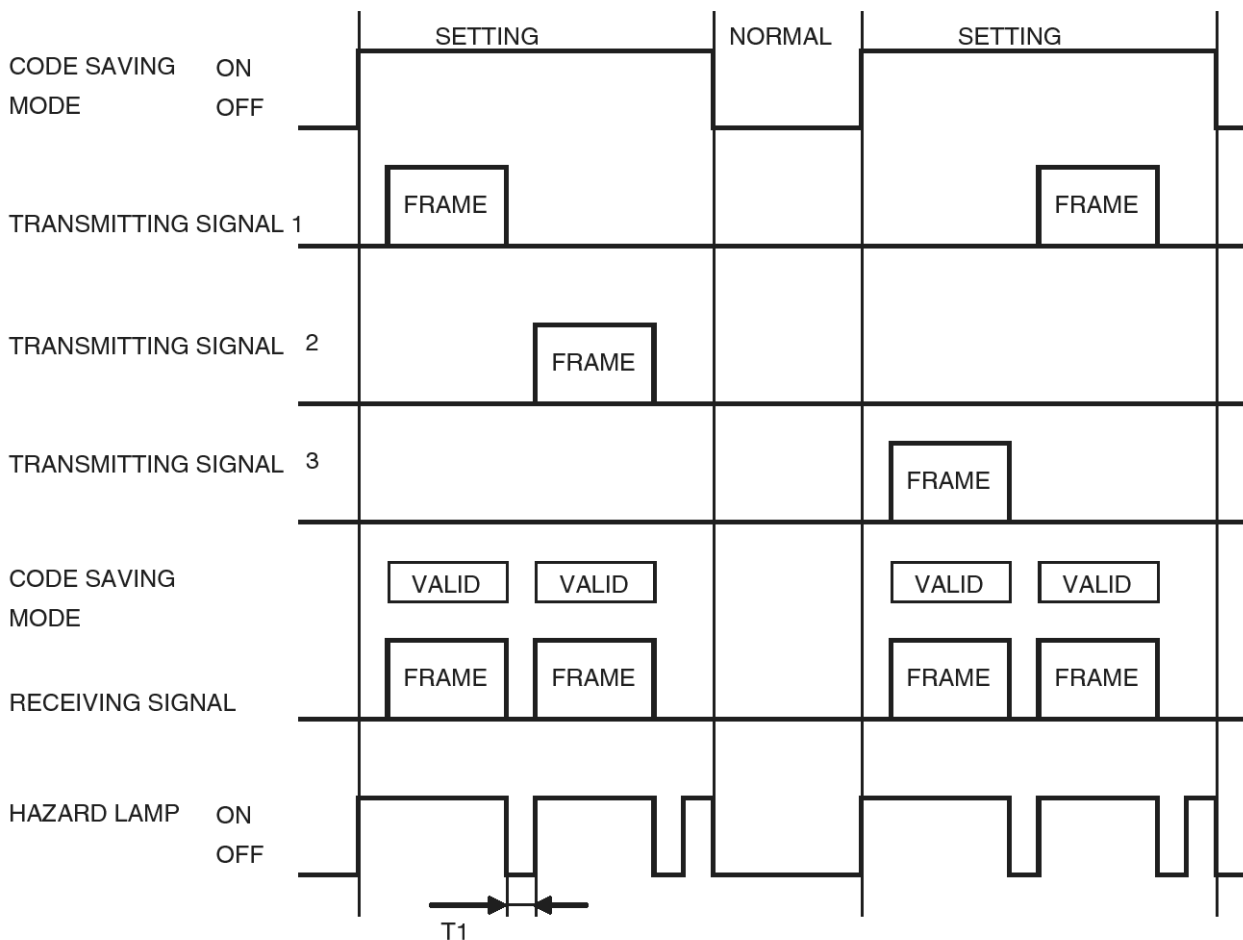

T1 : 1sec±10%

1) KEYLESS ENTRY operating specification.

In the ACC OFF state, according to requesting of LOCK or UNLOCK from the TX, it operates the same sequence as the CENTRAL DOOR LOCK.

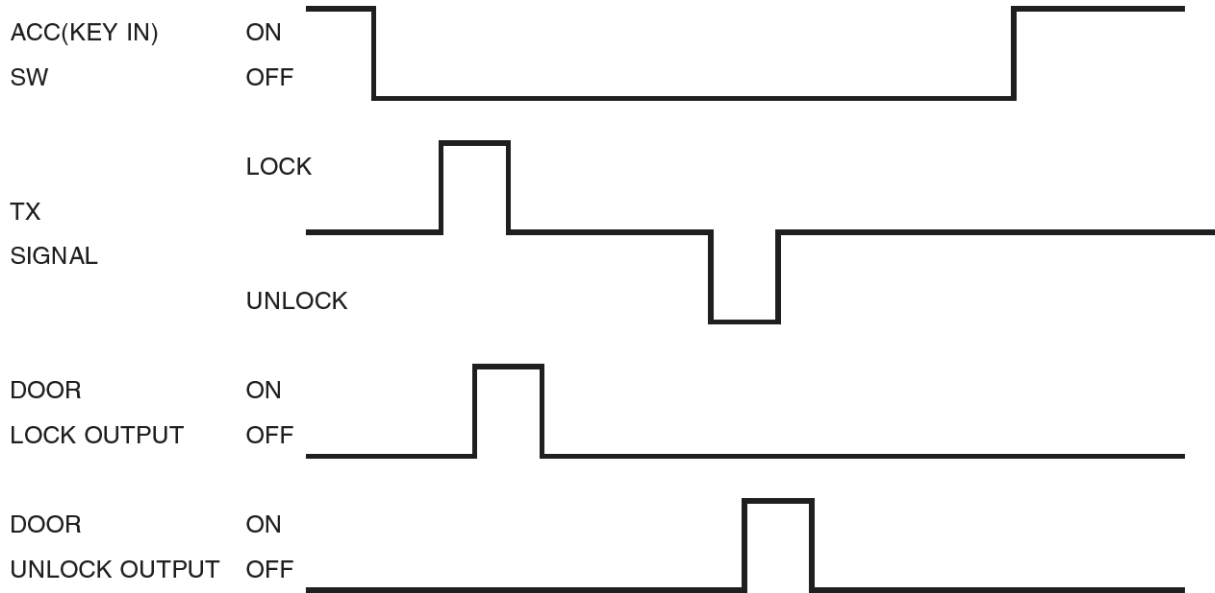

2. Burglar alarm function

1) ARM FUNCTION

1. In case LOCK signal of Tx is received when both Doors are Closed and ACC is OFF as well, output the LOCK state. After confirming LOCK of both Doors LOCK SW, turn on/off the HAZARD LAMP once for TARM cycle and turn on the HORN once for T\_ACK and then enter the ARM stage.

2. If the LOCK signal of Tx is received when any door is opened, LOCK only outputs, HAZARD LAMP and HORN is not outputted, ARM stage also is not entered.

3. After 2. , in case of closing all the opened door, after confirm of two doors LOCK SW, turn on/off HAZARD LAMP once for T\_ARM cycle and then turn on the HORN just one time for T\_ACK and enter the ARM stage.

4. It is only possible to receive LOCK signal of Tx in the ARM stage, but do not be entered ARM stage by DOOR KEY in LOCK stage.

5. And otherwise, relock doesn't output by Tx LOCK in all doors locked, HAZARD LAMP only turns on/off twice for T\_ARM cycle.

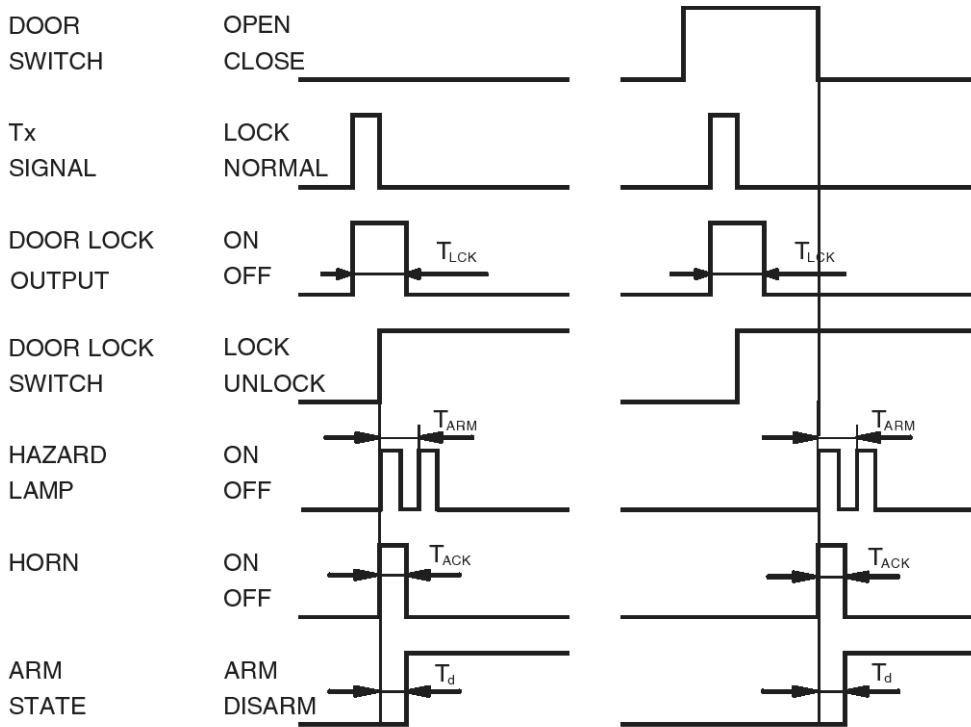

$T_{LCK}$ (DOOR LOCK ACTUATOR OUTPUT TIME)	: $0.5 \pm 0.1$ sec
$T_{ARM}$ (ARM MODE INDICATING LAMP TIME)	: $1.0 \pm 0.2$ sec
$T_{ACK}$ (ACKNOWLEDGE SIGNAL TIME OF HORN)	: $75 \pm 10$ msec
$T_d$ (ARM MODE ENTERING DELAY TIME)	: 0.2 sec MAX.

6. In the states of ACC OFF & ALL DOOR CLOSE & DOOR LOCK, after processing UNLOCK signal from Tx, if there's not the ACC ON, DOOR OPEN or LOCK output (LOCK by Tx, KNOB SW) within 30 seconds, door will be relocked automatically.

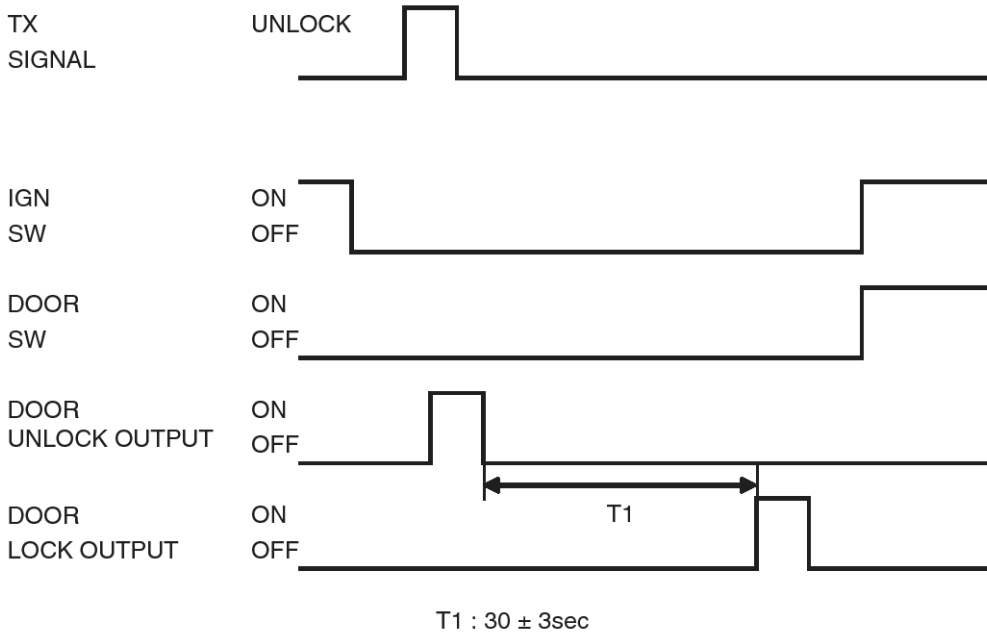

STRBE3028L

2) DISARM FUNCTION

1. Doors are unlocked by Tx UNLOCK and enter DISARM stage.

2. Otherwise, in any case of DOOR UNLOCK stage(DISARM stage), when Tx UNLOCK is to be outputted, the HAZARD LAMP only turns on/off once for T\_DSM.



3. If the ACC is ON in the ARM stage, there should be the DISARM stage.

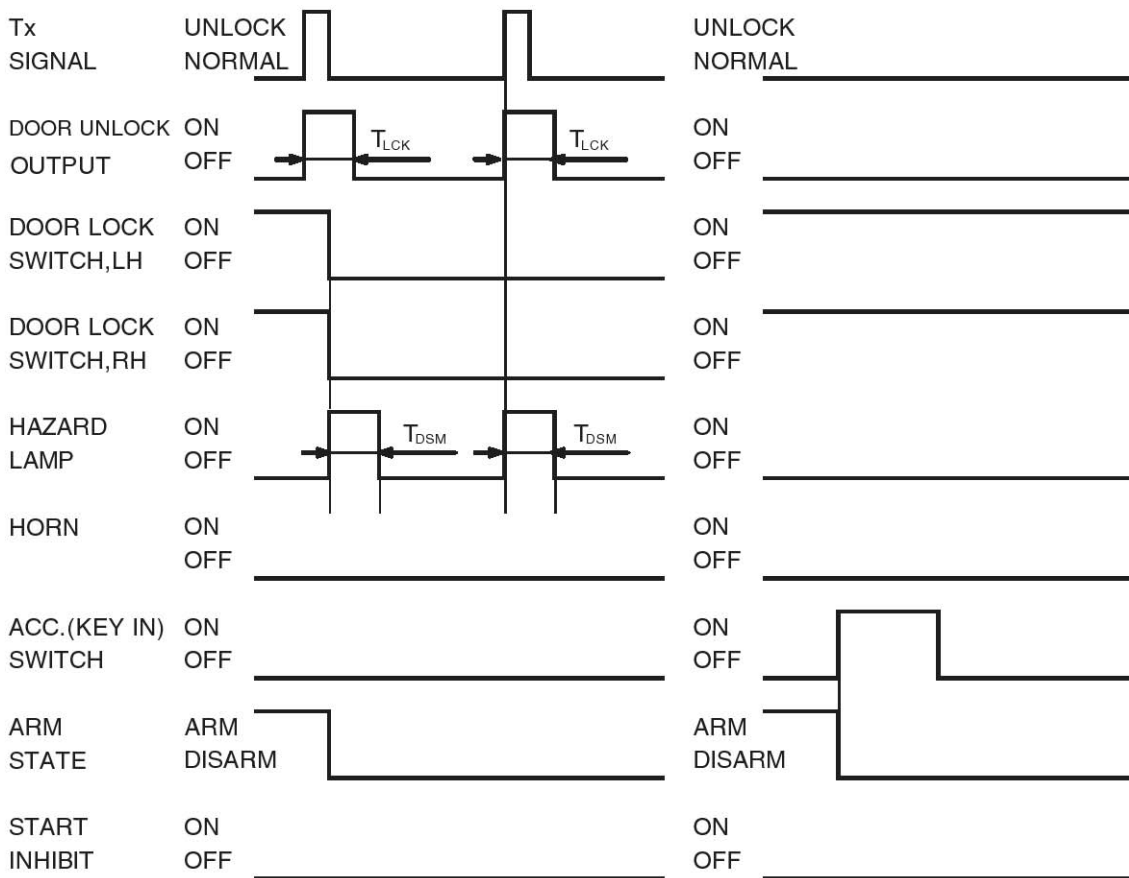

$T_{LCK}$  (DOOR LOCK ACTUATOR OUTPUT TIME) :  $0.5 \pm 0.1$  sec  
 $T_{DSM}$  (DISARM MODE INDICATING LAMP TIME) :  $1 \pm 0.2$  sec

STRBE3029L

### 3) ALARM FUNCTION

1. All Doors are Unlocked regardless of Tx in the ARM MODE. In case Doors is opened more than one, START INHIBIT is ON and prohibit the engine starting for  $T_{INH}$  and HAZARD LAMP is ON/OFF repeatedly in intervals  $T_{HZD}$  (DUTY :50%). The HORN repeats ON/OFF for  $T_{HZD}$  and HORN & HAZARD LAMP is OFF for  $T_{PAU}$  in three times.

The HAZARD LAMP is ON/OFF as much as the time of HORN.

2. Though the door is re-Locked or re-Closed during the alarm, alarm activates for the rest of time.

If anyone makes an invasion again, alarm activates for three times again.

3. The START INHIBIT turns off after turning on for  $T_{INH}$ .

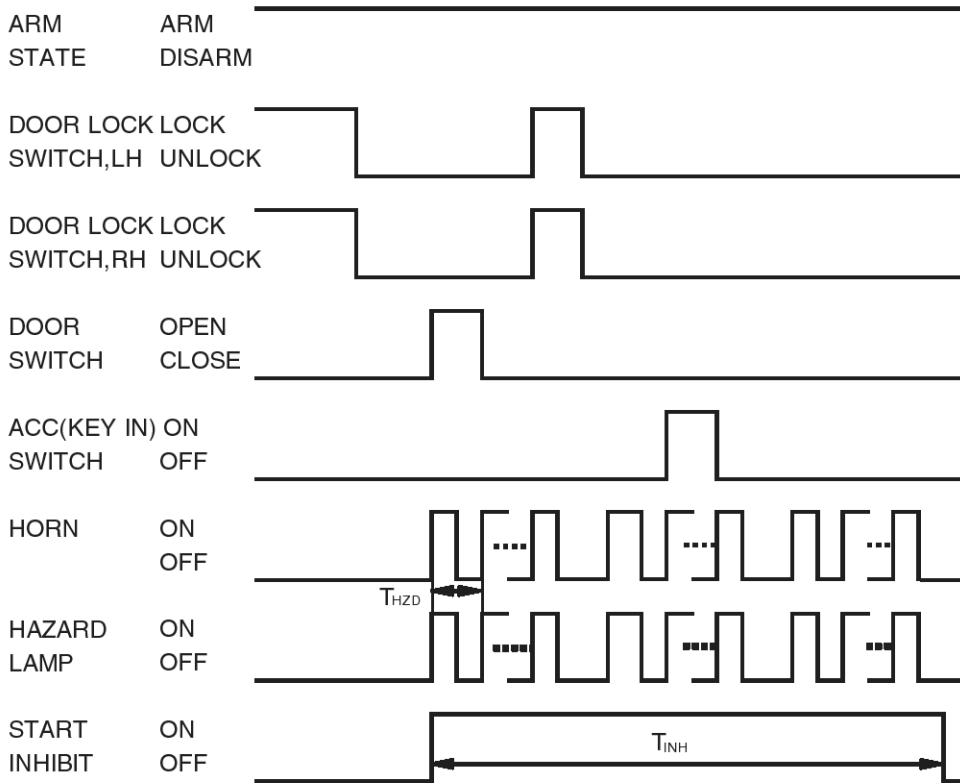

$T_{HZD}$  (HAZARD LAMP & HORN BLINKING CYCLE) :  $1 \pm 0.2$  sec (DUTY:50%)  
 $T_{INH}$  (START INHIBIT HOLDING TIME) :  $10 \pm 2$  min  
 $T_{SIR}$  (HAZARD LAMP & HORN ALARM TIME) :  $27 \pm 2$  sec  
 $T_{PAU}$  (HAZARD LAMP & HORN ALARM PAUSE TIME):  $10 \pm 1$  sec

STRBE3030L

4. If there is received the ACC input within 15 seconds after alarm is starting, and when it is passed by 30 seconds after ACC ON at first, the alarming and warning should be canceled and then ignore ACC input after 15 seconds.

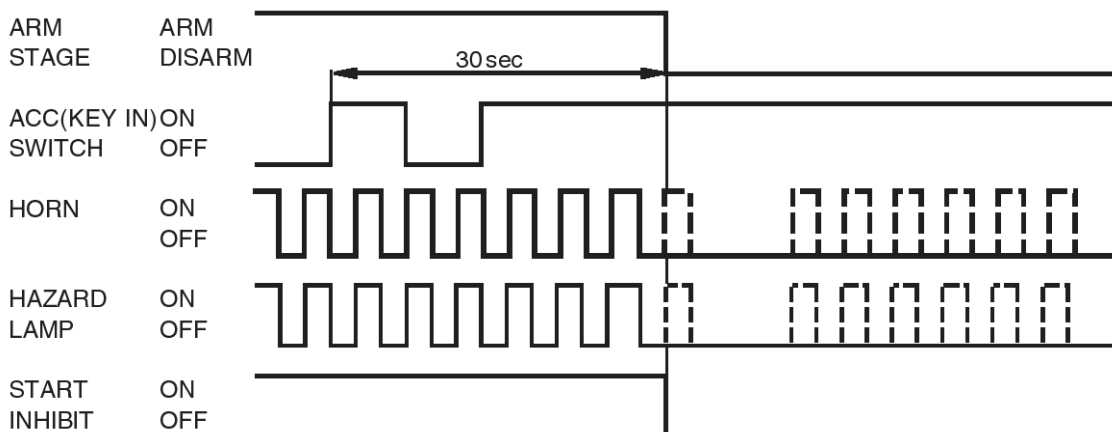

5. In case it is received the LOCK of Tx after closed the invaded DOOR during an alarm, the LOCK output is turned on for  $T_{LCK}$ . The HORN alarm output and START INHIBIT output are turned off. It confirms the two DOOR LOCK SW and turning ON/OFF the HAZARD LAMP one times for  $T_{ARM}$  cycle, the HORN is turned on for  $T_{ACK}$  and remains to the ARM stage.

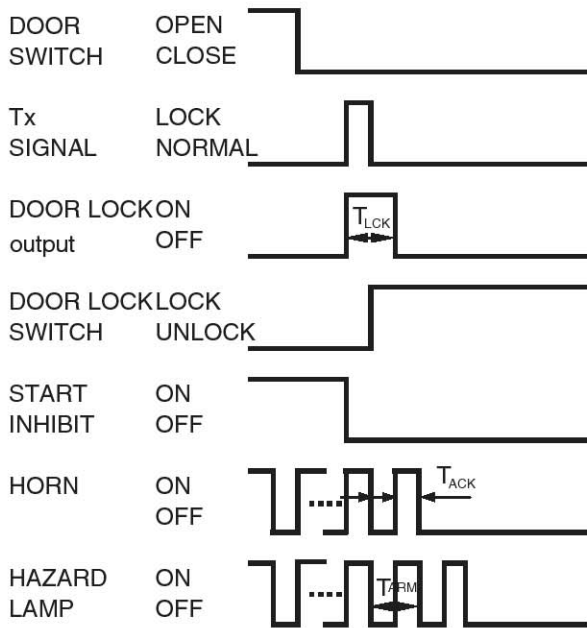

$T_{LCK}$ (DOOR LOCK ACTUATOR OUTPUT TIME)	: $0.5 \pm 0.1$ sec
$T_{ARM}$ (ARM MODE INDICATING LAMP TIME)	: $1.0 \pm 0.2$ sec
$T_{ACK}$ (ACKNOWLEDGE SIGNAL TIME OF HORN)	: $75 \pm 10$ msec

6. In case of Tx LOCK in the DOOR OPEN state during an alarm.

When the invaded DOOR is Opened during alarm and the LOCK of Tx is received, turn ON the LOCK output for T<sub>LCK</sub> and turn off the HORN alarm output and START INHIBIT output. It confirms the two DOOR LOCK Switches. When the opened DOOR is closed, the HAZARD LAMP is turned ON/OFF once for T<sub>ARM</sub> cycle, it turns ON the HORN for T<sub>ACK</sub> and remains to the ARM stage.

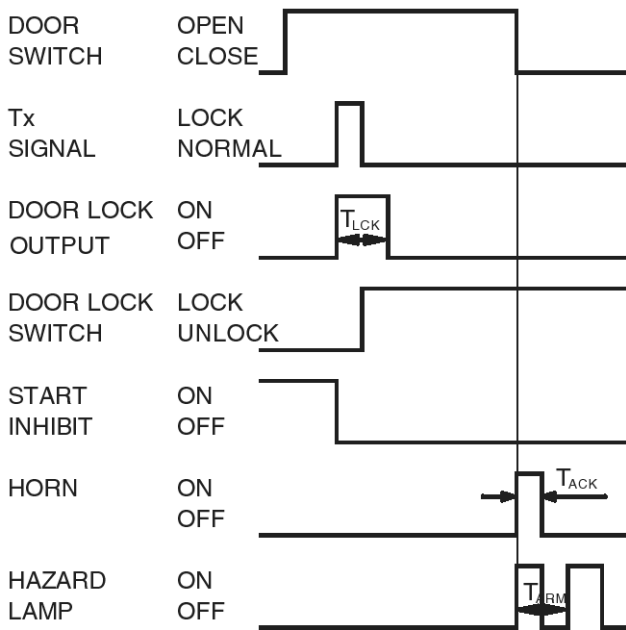

- T<sub>LCK</sub> (DOOR LOCK ACTUATOR OUTPUT TIME) : 0.5 ± 0.1 sec
- T<sub>ARM</sub> (ARM MODE INDICATING LAMP TIME) : 1.0 ± 0.2 sec
- T<sub>ACK</sub> (ACKNOWLEDGE SIGNAL TIME OF HORN) : 75± 10 msec

7. In case of removing the BATTERY(ARM state, NO ALARM state)

If the BATTERY is removed and then re-connected in ARM stage, START INHIBIT should be ON.

Alarm the HORN and HAZARD LAMP. If UNLOCK of Tx is to input during an alarm, the state will be the DISARM and immediately stop the HORN. HAZARD LAMP will be ON/OFF twice for  $T_{DSM}$ .

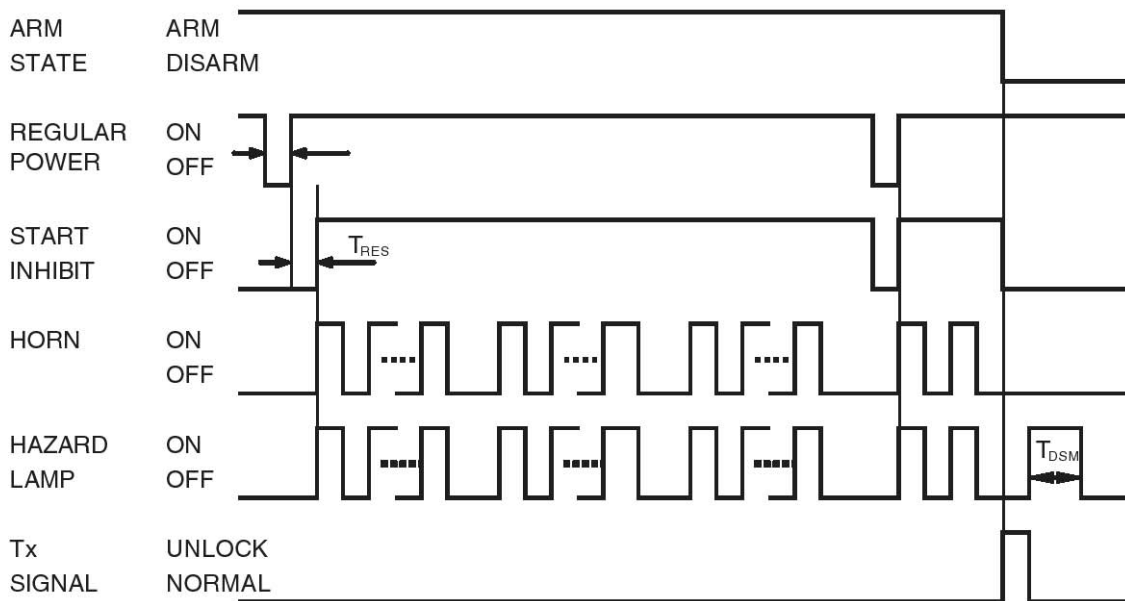

$T_{DSM}$  (DISARM MODE INDICATING LAMP TIME) :  $1.0 \pm 0.2$  sec (DUTY:50%)  
 $T_{RES}$  (CPU RESTART TIME) :  $2 \pm 1$  MAX

8. In case of removing the BATTERY(ALARM state)

If the BATTERY is removed and then re-connected during an alarm, START INHIBIT will be ON and alarm the HORN and the HAZARD LAMP.

If UNLOCK of Tx is to input during an alarm, the state is the DISARM and the HORN is immediately stopped.

HAZARD LAMP should be ON/OFF twice for  $T_{DSM}$ .

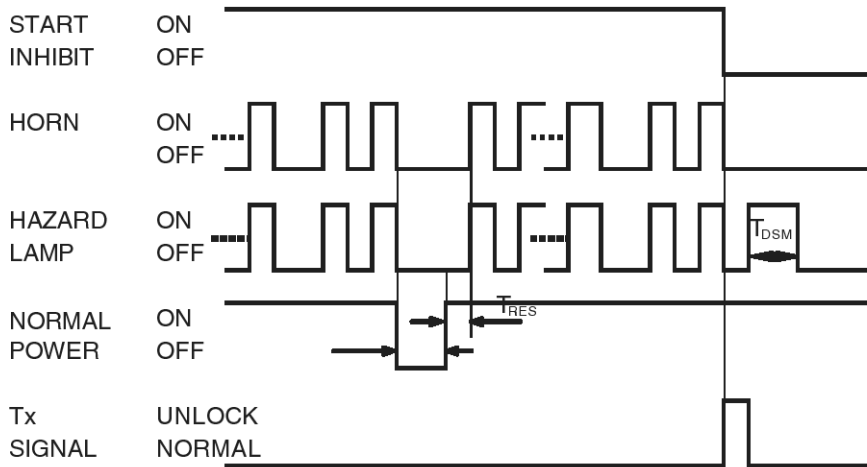

$T_{DSM}$ (DISARM INDICATING LAMP TIME) :  $1.0 \pm 0.2$  sec (DUTY:50%)  
 $T_{RES}$ (CPU RESTART TIME) :  $2 \pm 1$  MAX

STRBE3035L

9. ALARM function according to the CAB condition of the ARM MODE ENTRY.

1) If the CAB is Opened in the ARM MODE entry, ALARM function will have nothing to the CAB condition.

2) If the CAB is Closed in the ARM MODE entry, ALARM function will be operated in case the CAB is opened.

## INSPECTION TRANSMITTER

1. Check that the red light flickers when the door lock or unlock button is pressed on the transmitter.
2. Remove the battery and check voltage if the red light doesn't flicker.

Standard voltage : 3V

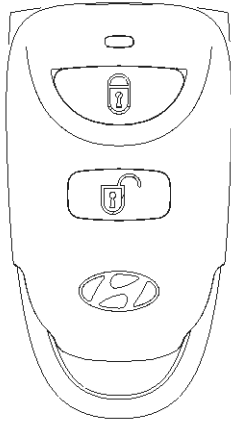

SUDBEA0048L

3. Replace the battery after removing the battery cover.
4. Replace the battery without delay if the battery is run down.

If the transmitter doesn't operate after replacing the battery, register again according to the transmitter code registration procedures, then check the operation.

Replace the remote transmitter only if the transmitter doesn't operate normally.

ADJUSTMENT

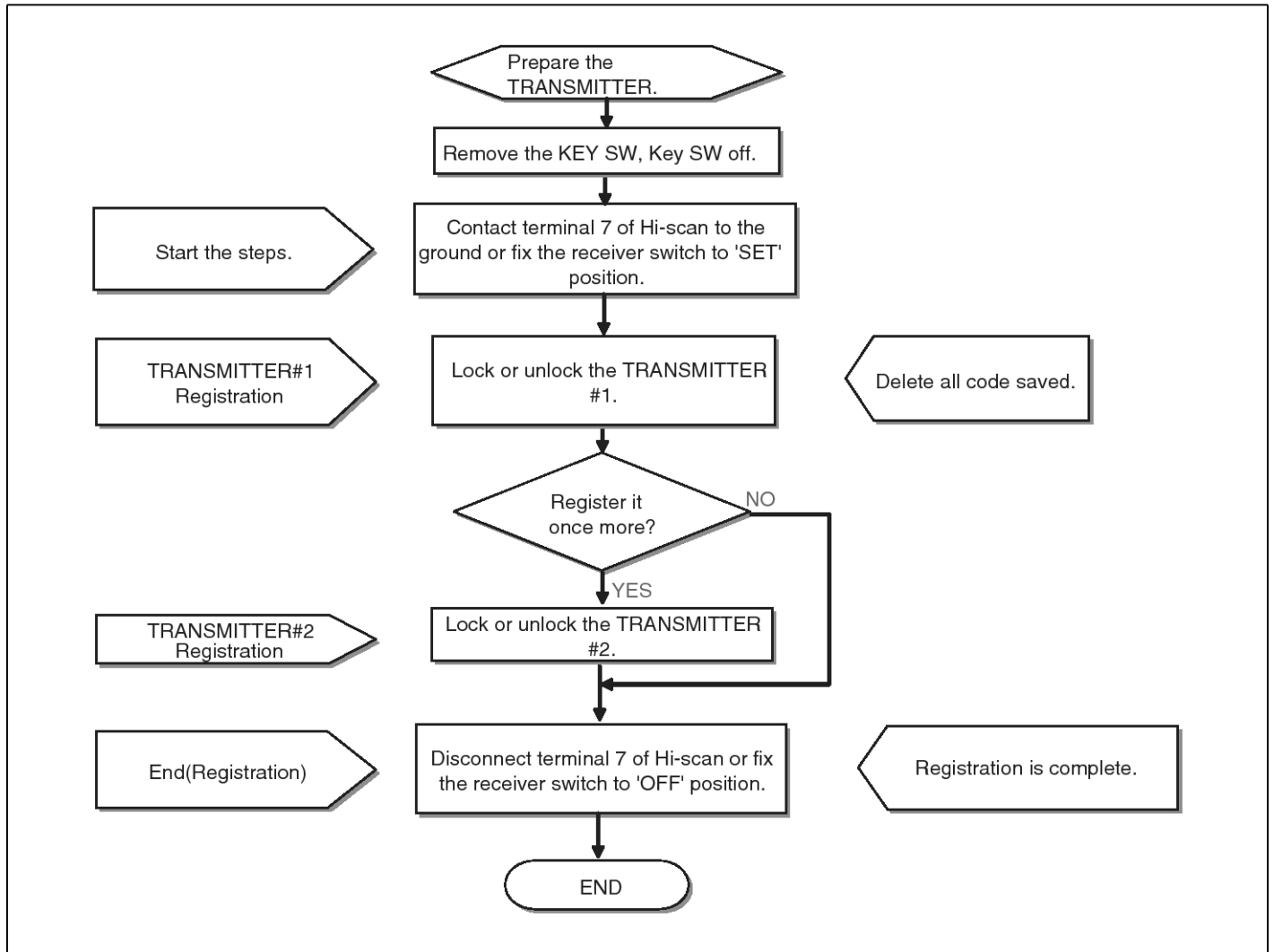

STRBE3009L

Specifications

Items	Specifications
Keyless entry transmitter power source	Lithium 3V battery (1EA)
Transmissible distance	10m or more
Life of battery	2 years or more (at 20 times per day)
Button	Door lock
	Door unlock
Transmission frequency	433.92 MHz



## Door Lock Actuator

### Inspection

1. After disconnect the door lock actuator connector(A), remove the door lock actuator mounting bolts(B)
2. After connecting the battery power to each terminals, check that the door lock actuator is normal operating.

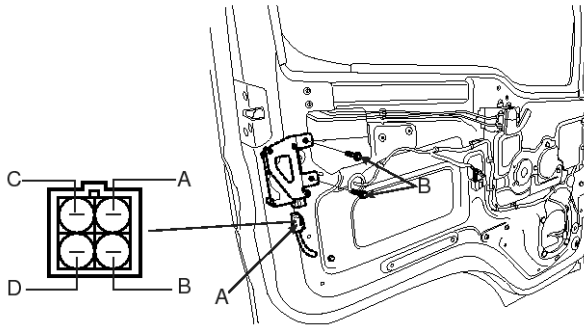

KMTBE5104A

State Terminal	LH	Lock	Unlock
	RH	Unlock	Lock
A		-	+
B		+	-

EMTBE5043A

## Digital Tachograph

### Specification

Items	Specification
Rated voltage	24 V DC
Range of voltage	18~32 V DC
Range of temperature	-30 ~ + 80 °C
Range of storage temperature	-35 ~ + 85 °C
Operating current	500 mA or low
Insulation resistance	100 MΩ or high (measured by 500V Megger)
Dark current	2mA or low

### Description

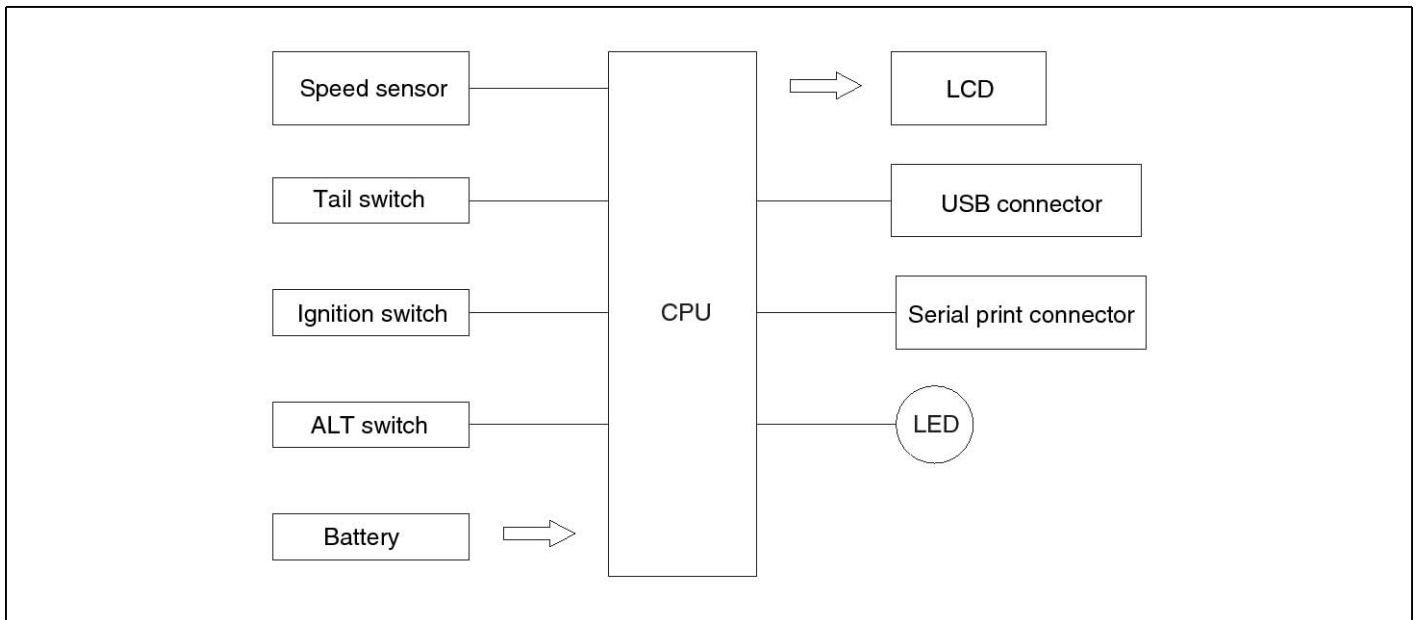

SUDBEA0035L

### Structure of menu

1. Inquiry : Date
2. Trip report : USB Download, Print
3. Configure : Date/Time, Vehicle ID No. , Language
4. Personalize : Driver select, Driver input, Driver upload, License plate, Fleet name
5. Firmware upgrade : Firmware version information

## Components

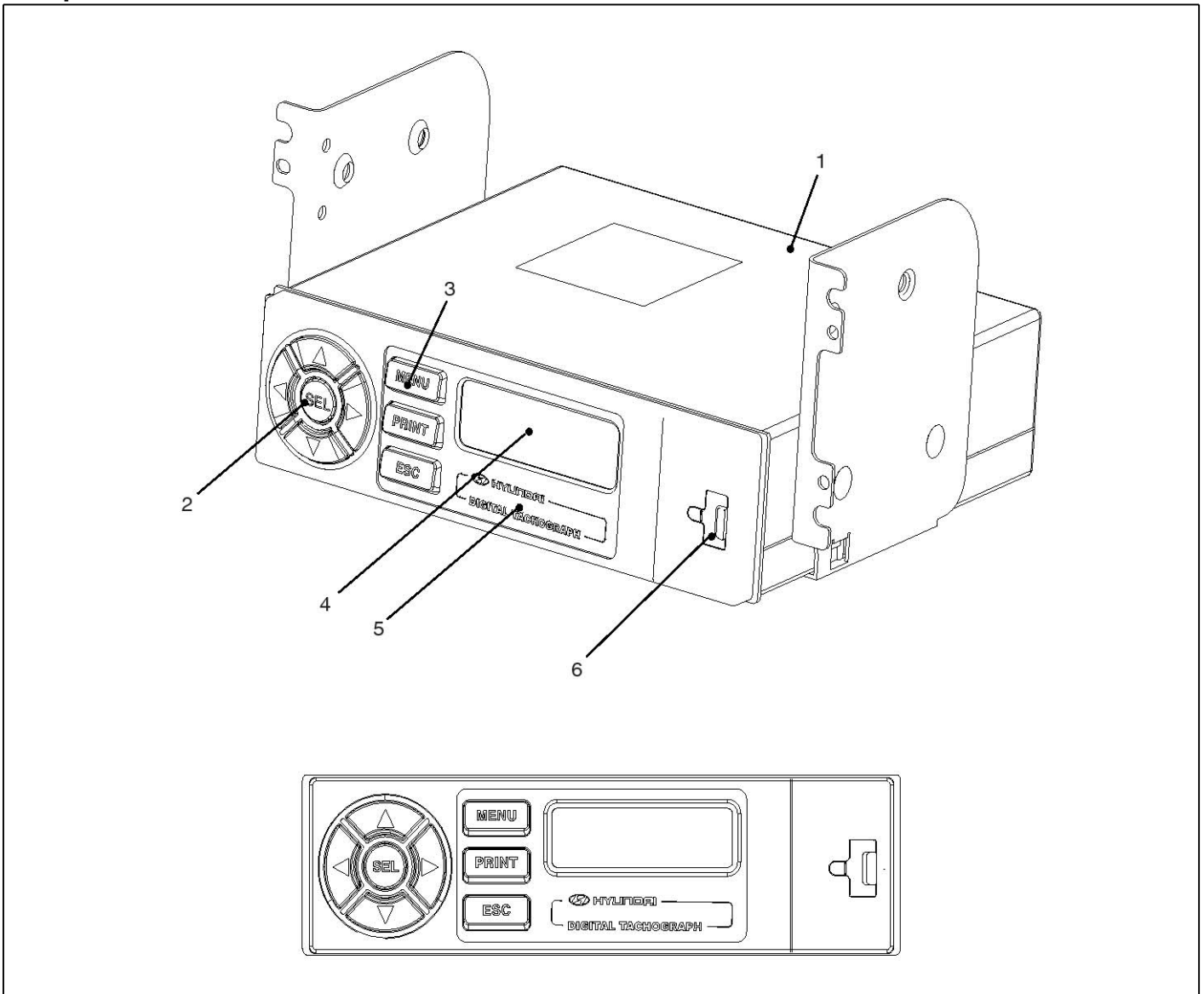

SUDBEA0036L

- 1. Upper case
- 2. Select switch
- 3. Switch

- 4. LCD monitor
- 5. Front case
- 6. USB terminal

Part circuit diagram

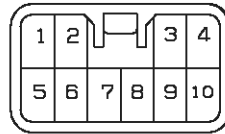
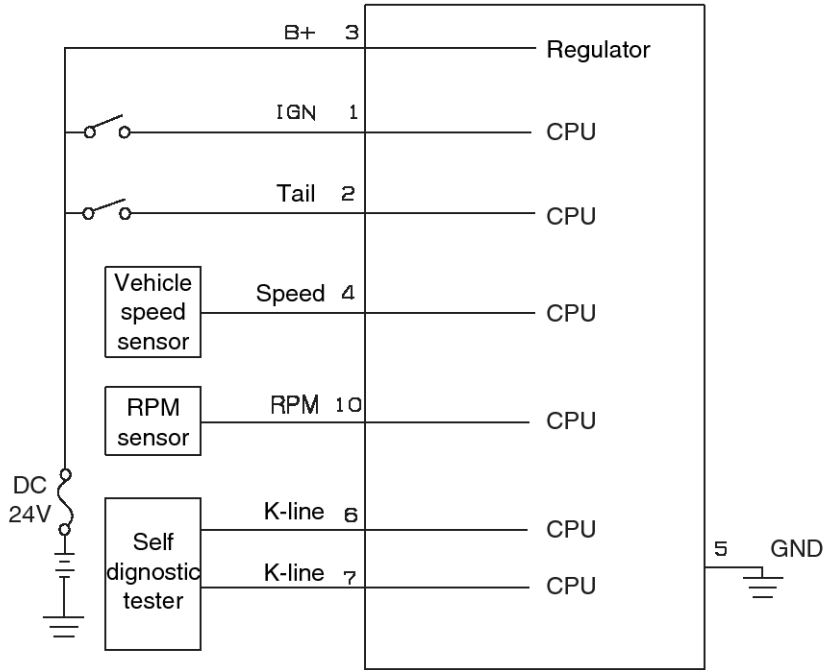

Pin number	Description
1	Ignition ON signal
2	Tail lamp signal
3	Battery(B+)
4	Vehicle speed input
5	Ground(GND)
6	K-line
7	L-line
8	AUX signal
9	AUX input
10	RPM signal input

### Replacement

- 1. Remove the center facia panel.
- 2. Disconnect the connector and remove the digital tachograph.
- 3. The installation is in the reverse order of removal.

### DTC chart

DTC code	Description
C1271	Engine rpm sensor open/short
C1212	Vehicle speed sensor open/short

## Audio System

### Audio Unit

#### Components

[ H0420 ]

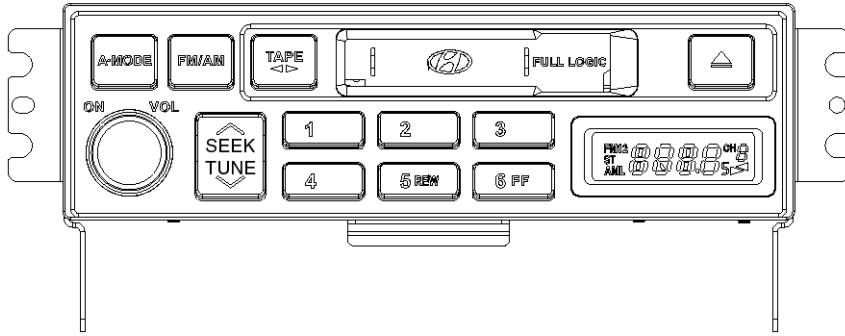

<Front side>

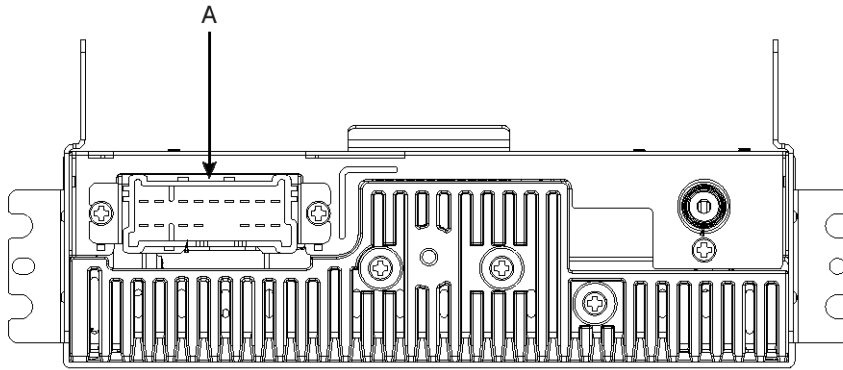

<Rear side>

Connector - 16 pins(A)

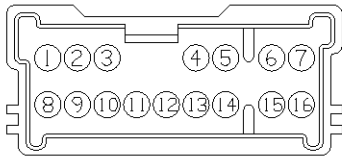

No.	Description	No.	Description
1	-	9	Rear speaker LH(+)
2	Rear speaker LH(-)	10	Front speaker LH(+)
3	Front speaker LH(-)	11	
4	Front speaker RH(-)	12	
5	Rear speaker RH(-)	13	Front speaker RH(+)
6		14	Rear speaker RH(+)
7	ACC(+)	15	Tail(+)
8	Ground	16	Back-up(+)

[ H0440 ]

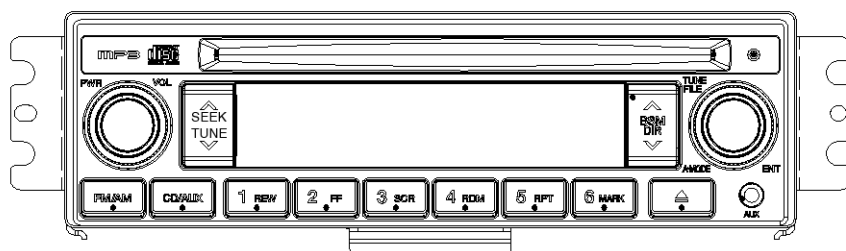

<Front side>

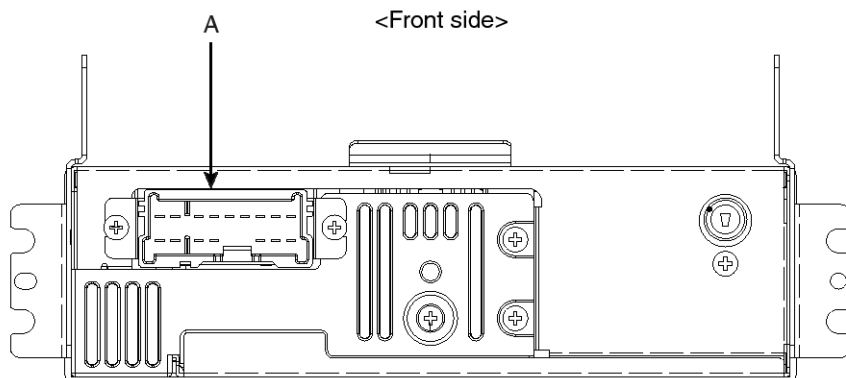

<Rear side>

Connector - 16 pins(A)

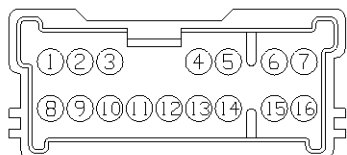

No.	Description	No.	Description
1	ANT, 12V	9	N.C
2	N.C	10	Front speaker LH(+)
3	Front speaker LH(-)	11	Remote control ground
4	Front speaker RH(-)	12	Remote control(+)
5	N.C	13	Front speaker RH(+)
6	Tail ground	14	N.C
7	ACC	15	Tail(+)
8	Ground	16	Back-up(+)

## Replacement

1. Disconnect the battery (-) cable.
2. Remove the left overhead facia panel.
3. Loosen the mounting bolt of audio unit. Disconnect the connector on the rear side and remove the audio unit.
4. The installation is in the reverse order of the removal.

## Cleaning

1. To maintain the best condition, clean the head and capstan periodically.

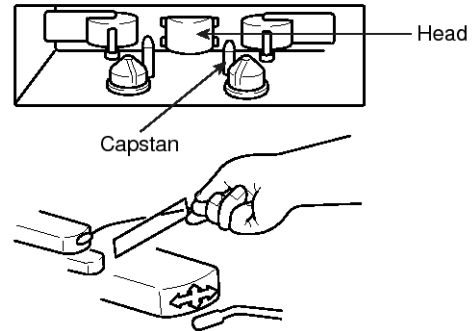

EMTBE5045A

2. When cleaning the tape head and capstan, use a cotton wet by alcohol.



## Speaker

### Replacement

1. Remove the tightening screw (A) for the power window switch assembly.

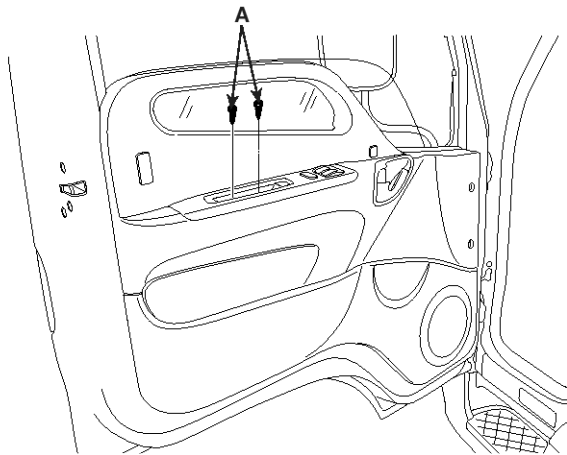

KMTBE5110A

2. Remove the power window switch assembly (A) by lifting it up from the front part. Remove the power window connector (B).

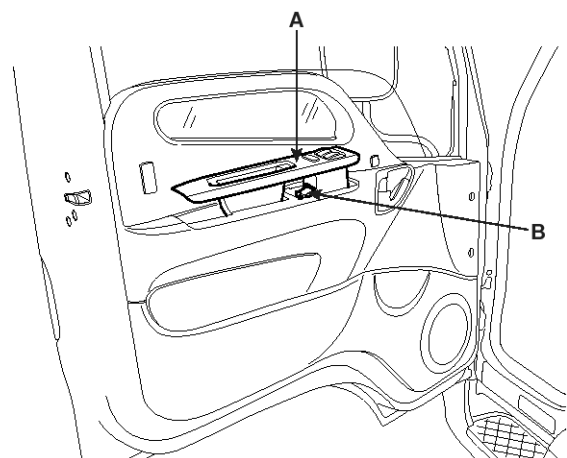

KMTBE5111A

3. Loosen the tightening screw (A) of the inside handle housing. Disassemble the inside handle housing (B) from the door trim (C).

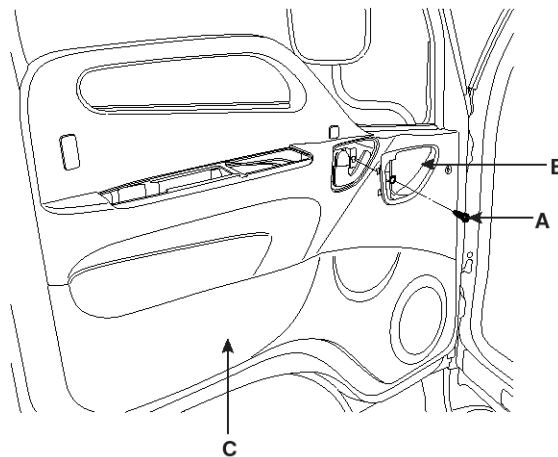

KMTBE5112A

4. Taking off the tightening screw (A) and bolt (B) from the door trim, remove the door trim (C).

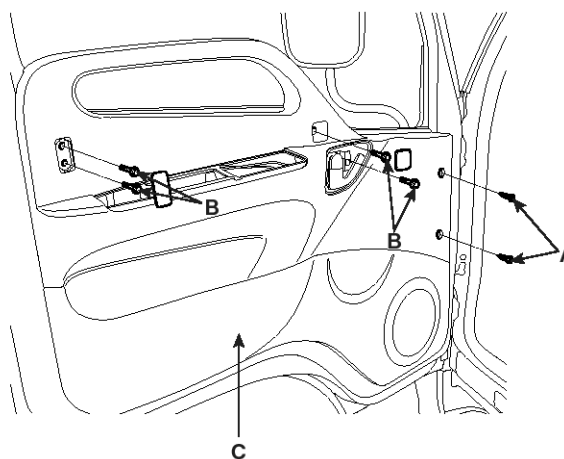

KMTBE5113A

5. Disconnect the speaker connector (A) and loosening the tightening screw (B), remove the speaker (C).

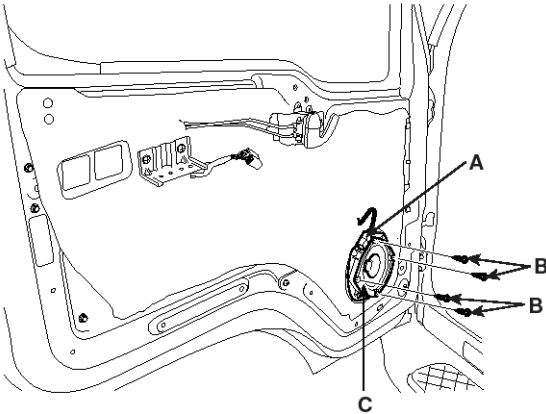

KMTBE5114A

6. Installation is performed in the reverse order of the removal.

## Inspection

1. Check the speaker using a resistance meter. When checking the (+) and the (-) of the same channel speaker, if the resistor meter indicates the impedance value, the speaker is normal.
2. If the speaker makes a sound when the plug of the resistor meter contacts to the speaker terminal, it is normal.

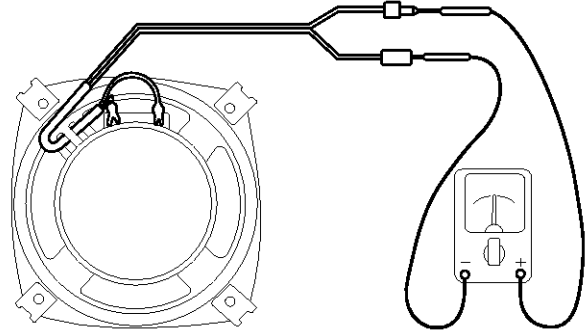

KMTBE5115A

## Horns

## Horns

## Component Location

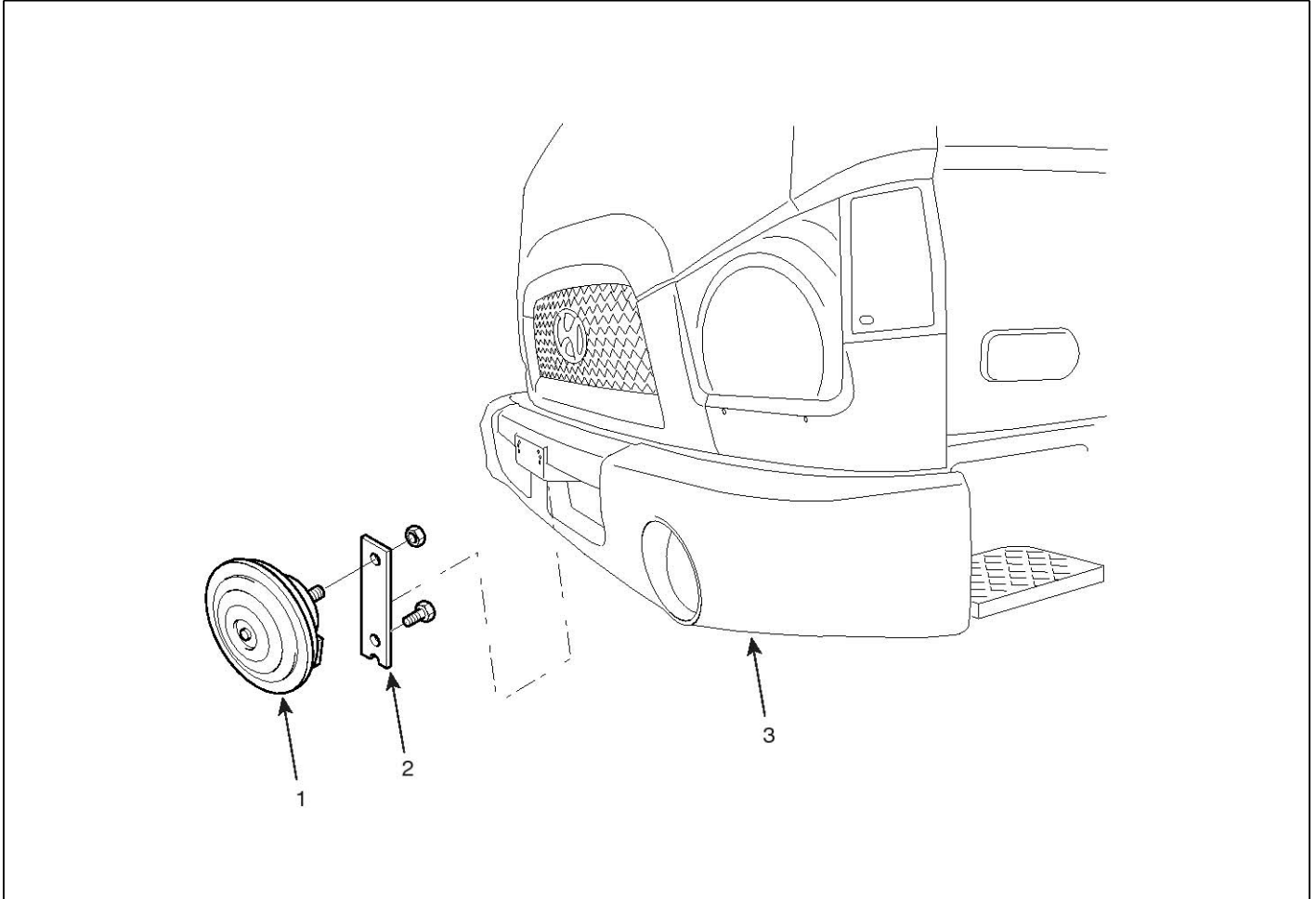

- 1. Horn
- 2. Bracket

- 3. Bumper

SUDBEA0049L

## Replacement

1. Disconnect the both fog lamp connectors (A).

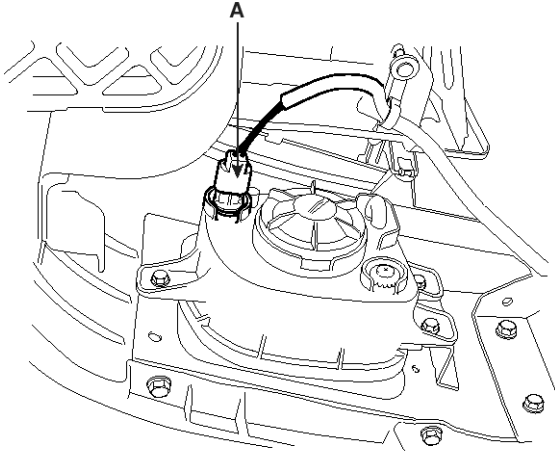

KMTBE5066A

2. After taking off the bolt (A), remove the bumper (B).

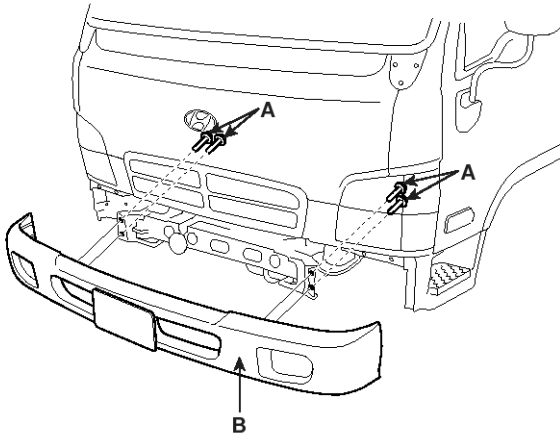

KMTBE5067A

3. After disconnect the horn connector(A), remove the mounting bracket(B).

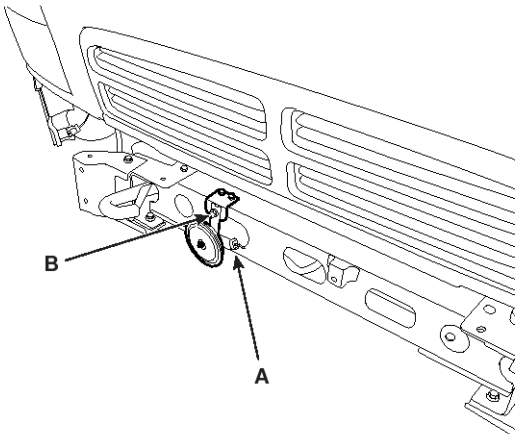

KMTBE5117A

4. The installation is performed in the reverse order of the removal.

### NOTICE

*Be ensure that the connector should be firmly connected.*

### Inspection

1. After connecting the battery power to the horn connector, check that the horn makes the sound.

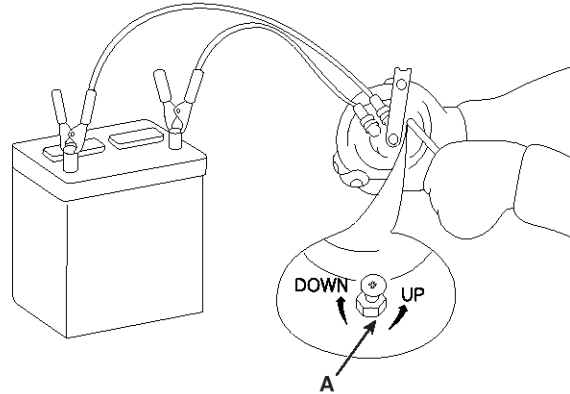

KMTBE5118A

2. If the sound pressure is not proper, adjust the sound pressure by rotating the adjusting screw (A).
3. If the horn does not make the sound, replace the horn.

## Electronic Time and Alarm Control System

### Components

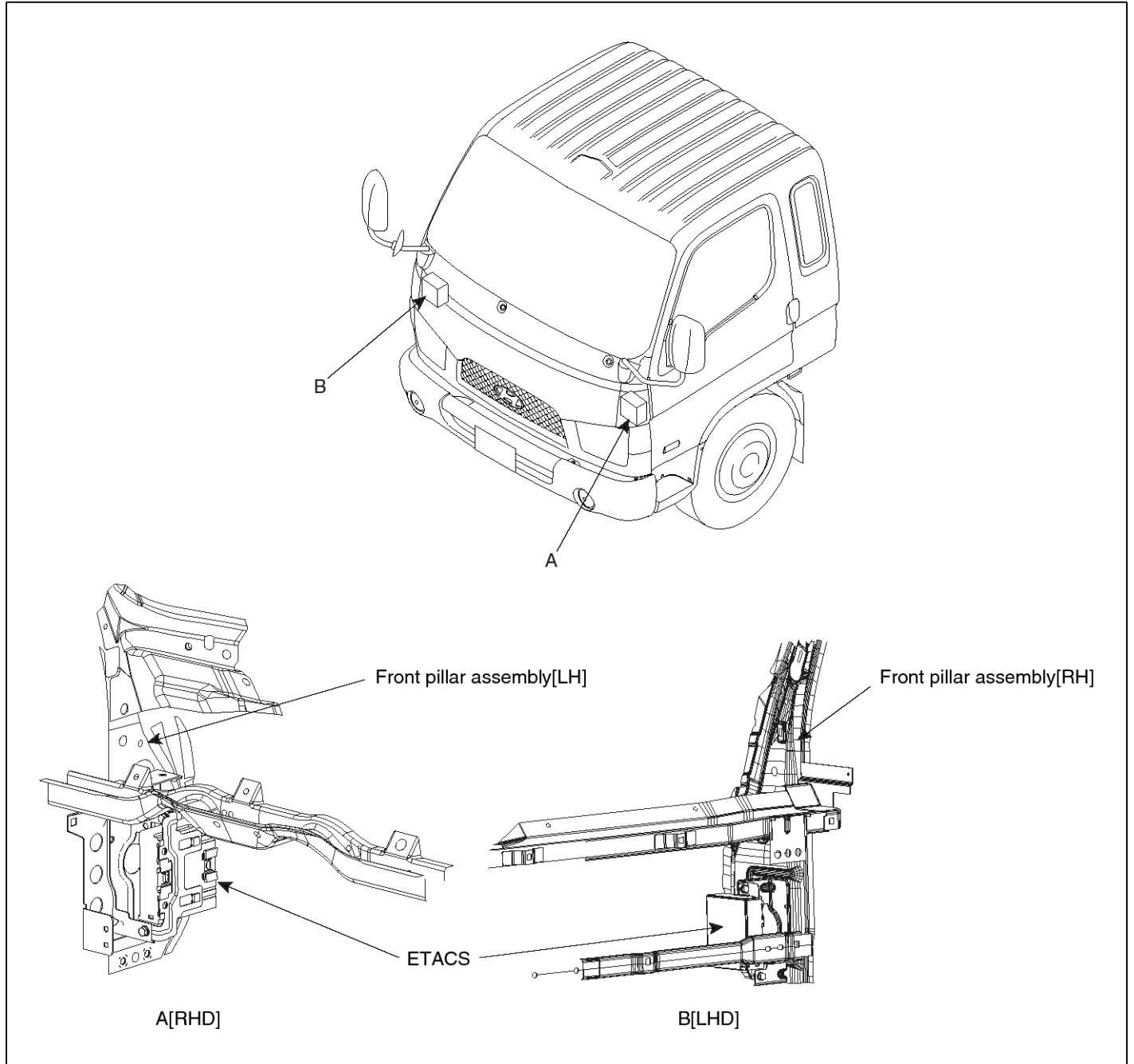

## Circuit Diagram

Except D4DD, D4GA engine

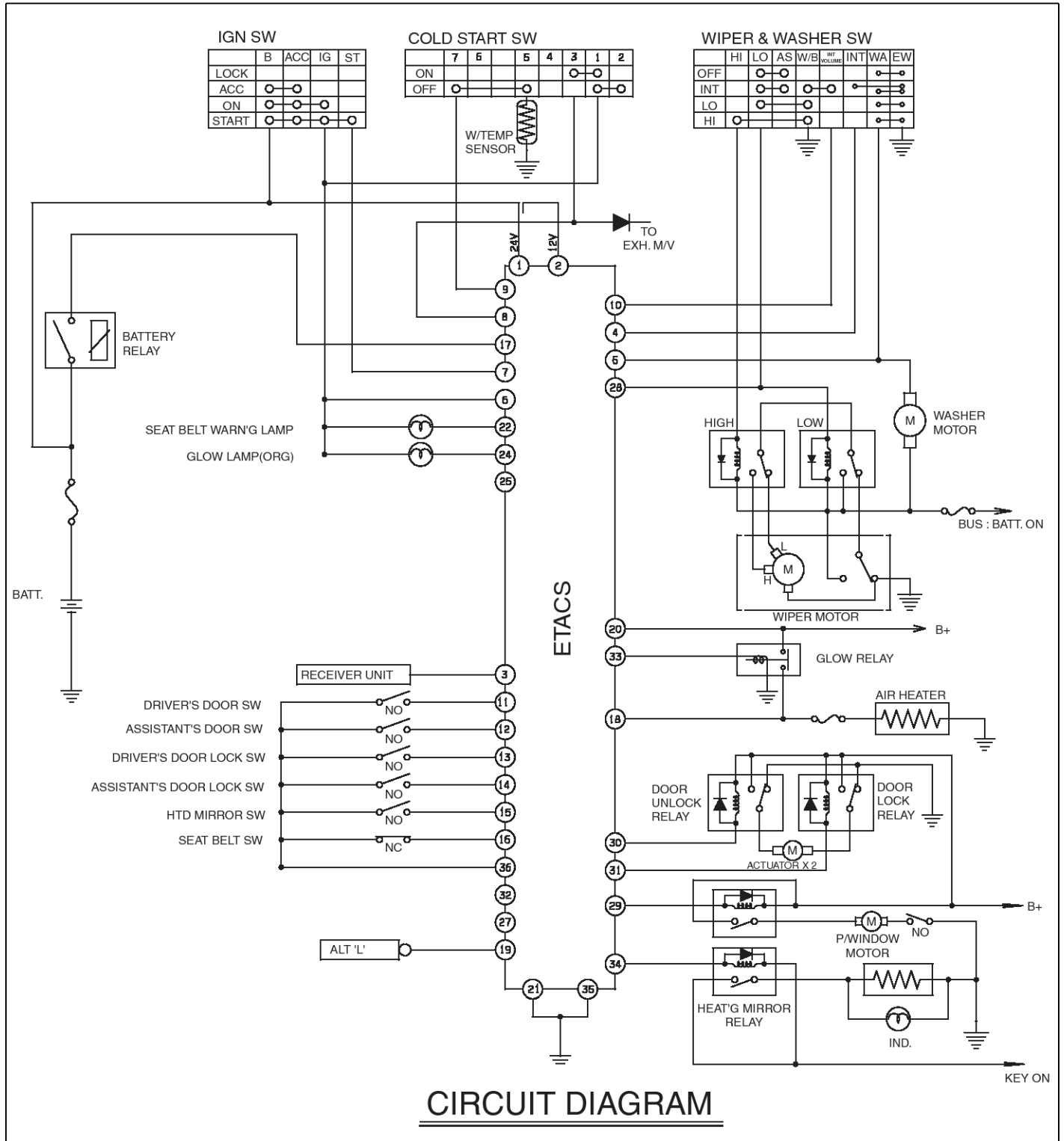

CIRCUIT DIAGRAM

D4DD, D4GA engine

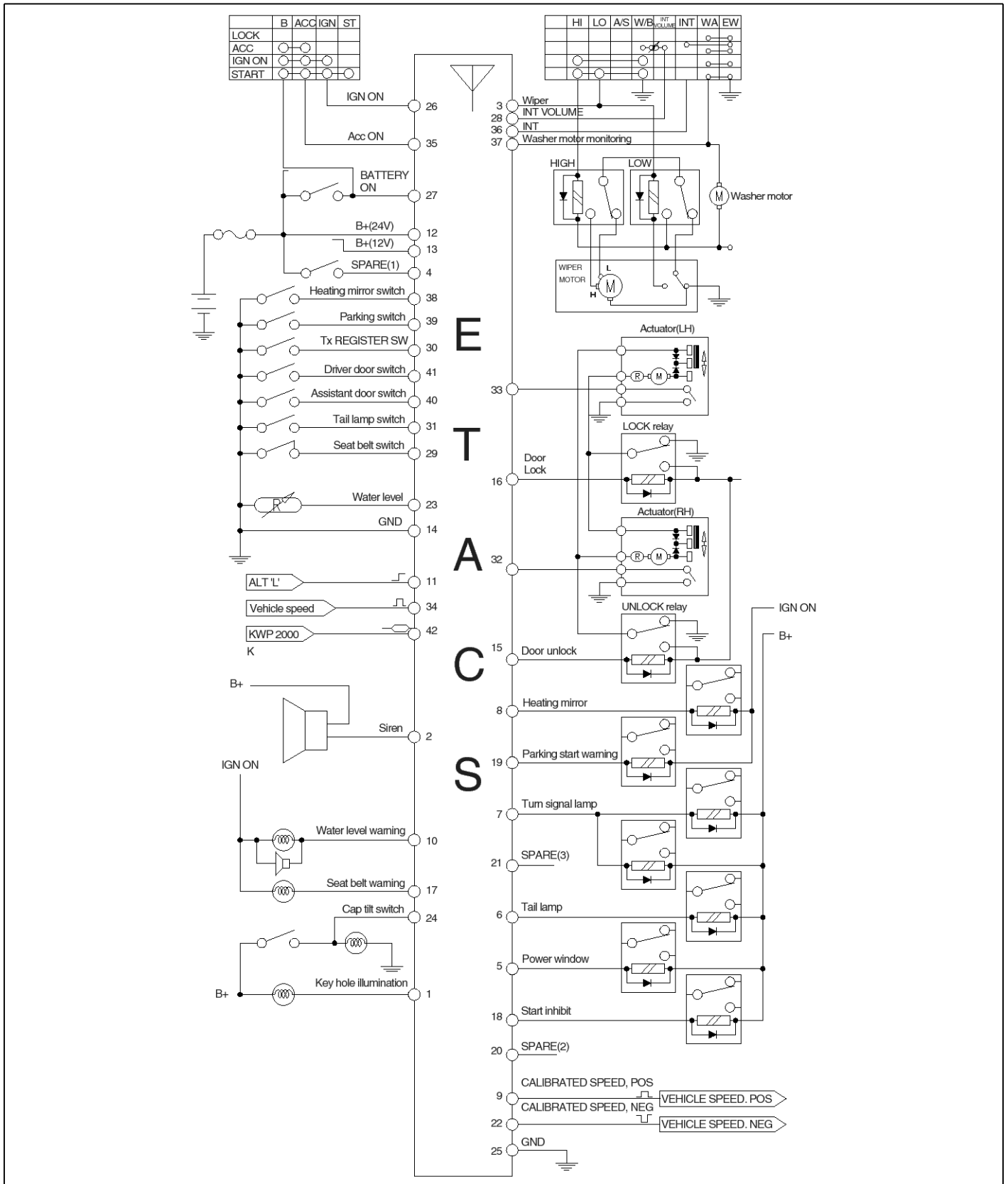

## Connector

Except D4DD, D4GA engine

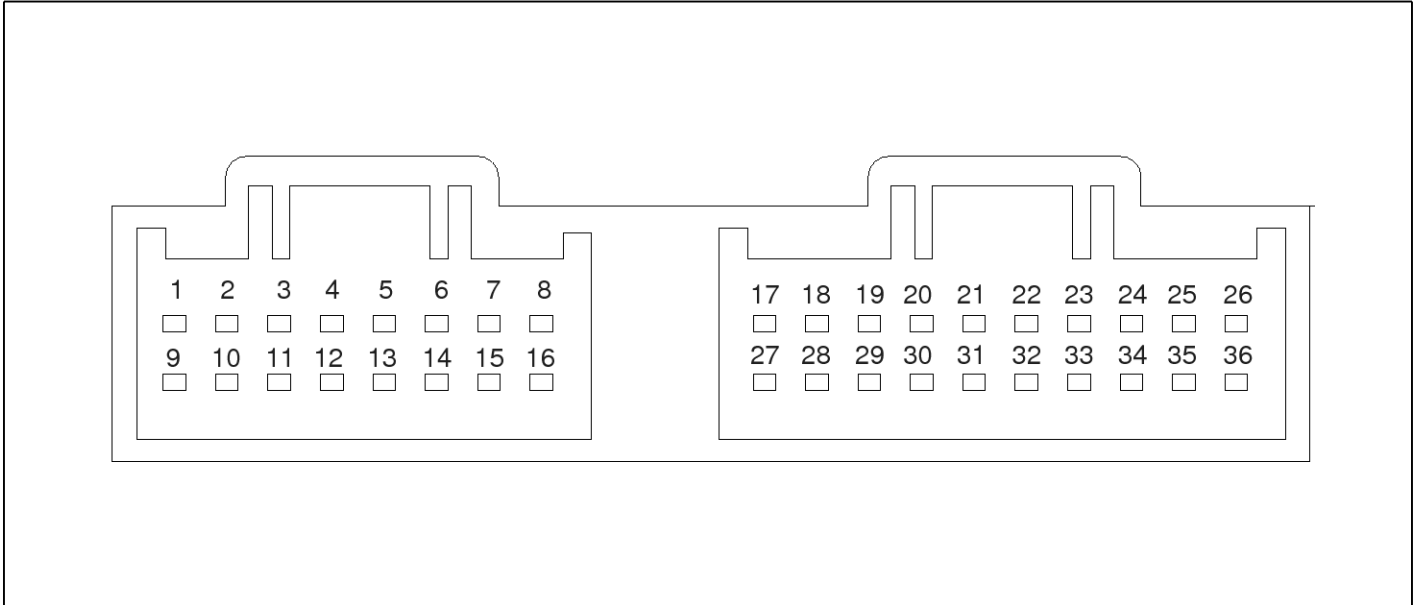

ECOB5027A

NO.	PIN FUNCTION	NO.	PIN FUNCTION
1	B+ (24V)	19	ALTERNATOR "L" TERMINAL
2		20	B+(SOURCE VOLTAGE)
3		21	GND
4	INT. WIPER SW	22	SEAT BELT WARN'G LAMP
5	WASHER SW	24	GLOW LAMP(AMBER)
6	MAIN SW(KEY ON)	25	
7	START SW	28	WIPER RELAY COIL
8	COLD START SW	29	POWER WINDOW RELAY
9	THERMISTOR	30	DOOR UNLOCK RELAY
10	INT. VOLUME	31	DOOR LOCK RELAY
11	DRIVER'S DOOR SW	32	
12	ASSISTANT'S DOOR SW	33	GLOW RELAY COIL
13	DOOR LOCK SW(LH)	34	HEAT'G MIRROR RELAY
14	DOOR LOCK SW(RH)	35	GND
15	HEAT'G MIRROR SW	36	GND
16	SEAT BELT SW		
17	BATTERY SW(BATT.ON)		
18	GLOW RELAY LOAD READ'G		

EMTBE5048A



D4DD, D4GA engine

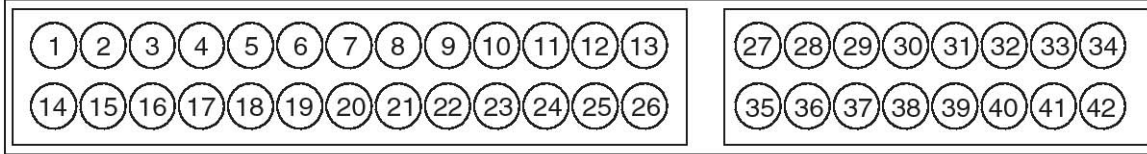

KMTBE5130A

PIN NO.	PIN NAME	PIN NO.	PIN NAME
1	KEY HOLE ILL.	22	CALIBRATED SPEED, NEG
2	SIREN	23	COOLANT LEVEL
3	WIPER LOW	24	-
4	SPARE(1)	25	GND(2)
5	POWER WINDOW RELAY	26	IGN ON
6	TAIL LAMP RELAY	27	BAT. ON
7	T/SIG LAMP RELAY	28	INT, VOLUME
8	HEATING MIRROR RELAY	29	SEAT BELT SW
9	CALIBRATED SPEED, POS	30	TX REGISTER SW
10	COOLANT LEVEL WARN'G IND.	31	TAIL LAMP SW
11	ALT 'L'	32	DR LOCK ACT, RH
12	B+ (24V)	33	DR LOCK ACT, LH
13	B+ (12V)	34	VEHICLE SPEED INPUT
14	GND(1)	35	ACC ON
15	DOOR LOCK	36	INT. SW
16	DOOR UNLOCK	37	WASHER MOTOR MONITOR
17	SEAT BELT WARNING IND.	38	HEAT, G MIRROR SW
18	START INHIBIT RELAY	39	PARKING SW
19	PARKING START WARNING RELAY	40	DOOR SW, RH
20	SPARE(2)	41	DOOR SW, LH
21	SPARE(3)	42	KWP2000, K

KCOBE5027A

**Specifications**

Item	Specifications
Nominal Voltage	DC 24V
Operating Voltage	DC 20~ 32V
Operating Temperature	-30 ~ +80°C (-22 ~ +176°F)
Dark Current	5mA or less
Nominal Load Seat Belt Warning Indicator Coolant Level Warning Lamp Wiper Relay Warning Relay Power Window Relay Door Lock/Unlock Relay Mirror Heater Relay Tail Lamp Relay Turn Signal Lamp Relay Siren Coolant Level Buzzer & Lamp	1.4W (Lamp Load) 1.4W (Lamp Load) 200mA (Coil Load) 300mA (Coil Load) 200mA (Coil Load) 200mA (Coil Load) 200mA (Coil Load) 200mA (Coil Load) 200mA (Coil Load) 200mA x 2 (Coil Load) 200mA (Coil Load) 200mA, 1.4W (Lamp Load)

## Generals

The ETACS is the system for automatic controlling the seat belt warning lamp, the pre-heating indicator, the pre-heater relay, the intermittent wiper relay, the mirror-heater relay, the door lock/unlock relay, the power window relay, and the tail relay. By receiving various switch signals, it outputs the functions related to the TIME control and ALARM control.

## OPERATING PRINCIPLE

### Except D4DD, D4GA engine

#### 1. Variable Intermittent Wiper

- 1) In the state that the ignition switch is ON.
- 2) In the state that the intermittent wiper switch is ON.

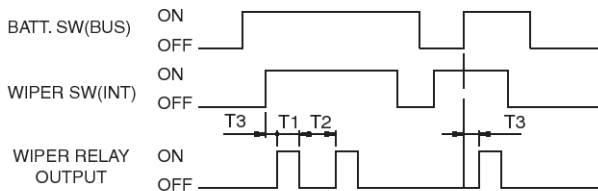

T1 : 0.6 ± 0.2 SEC  
 T2 : 2 ± 0.5 SEC (AT VR=0) ~ 11 ± 2 SEC (AT VR=50 KΩ)  
 T3 : 0.3 SEC MAX

ECOB5023A

#### 2. Washer related Wiper

- 1) At the ON of the ignition switch, if the washer switch is ON, after 1 sec, the wiper output is ON. When the washer switch input is within T3, after T4, the wiper output is OFF.
- 2) At the ON of the ignition switch, if the washer switch is ON, after 1 sec, the wiper output is ON. When the washer switch input is over T4, the washer switch is OFF and then the wiper output is ON for T2. After that, the washer switch is OFF.

- 3) This function is prior to the intermittent wiper function.

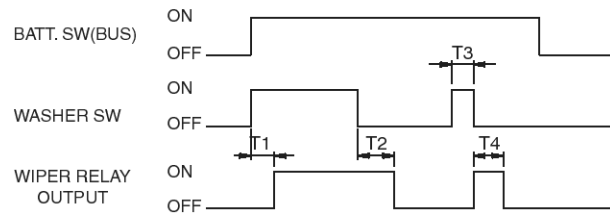

T1 : 0.5 ± 0.1 SEC  
 T2 : 2 ~ 3 CYCLE WIPER ROTATION  
 T3 : 0.2 ~ 0.4 SEC  
 T4 : 0.6 ± 0.2 SEC

ECOB5024A

#### 3. Central Door Lock Control

- 1) According to the input of the inside lock knob of the driver's or assistant's seat, the door lock/unlock can be performed.
- 2) Installation of battery should not change the locks. (KNOB is lock or unlock state, do not perform the lock output even if a battery is connected).

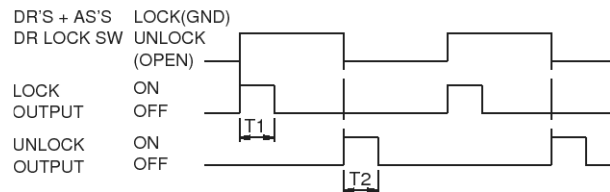

T1, T2 : 0.5 ± 0.1 SEC

EMTBE5052A

#### 4. Seat Belt Warning Timer

- 1) From the ignition switch ON, the seat belt warning lamp (with 0.6 periods) is output for T1.
- 2) Within the set time interval, if the ignition is OFF, the seat belt warning lamp is stopped.
- 3) Within the set time interval, if the seat belt switch is ON, the seat belt warning lamp continues for remained time. During output for remained time, if the seat belt is released again, the timer is reset.

- At the ON state of the ignition, if the seat belt is fastened and then released again, the warning lamp is output for T1.

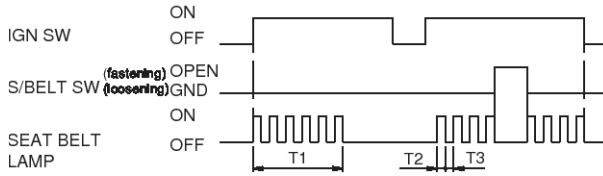

T1 : 6 ± 1 SEC  
T2, T3 : 0.3 ± 0.05 SEC

ECOBE5207A

## 5. Heating mirror Timer

- At the ON state of the ignition switch, if the heatwire switch is ON after the alternator "L" is ON, the heat-wire output is ON for T2.
- During heat-wire output ON, if the heat-wire switch is ON again, the heat-wire output is OFF.
- During heat-wire output ON, if the alternator "L" is OFF or the ignition is OFF, the heat-wire output is OFF.

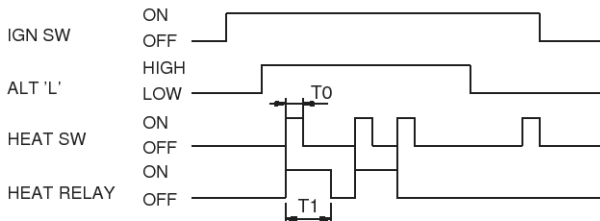

T0 : 60 msec MIN.  
T1 : 15 ± 2 MINUTE

EMTBE5050A

## 6. Water level warning

- At the ON state of the ignition switch, if the coolant level sensor is maintained over T1 with 30kΩ, the warning lamp is ON.
- If the coolant level sensor is maintained over T2 with less than 30kΩ, the warning lamp is OFF.

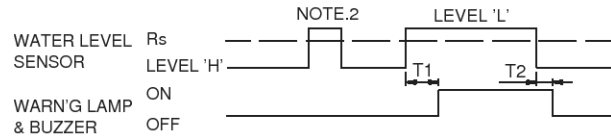

Rs : 30 ± 15 KW  
T1 (WARNING LAMP LIT DELAY TIME) : 1.5 ± 0.5 SEC  
T2 (WARNING LAMP OFF DELAY TIME) : 1 SEC MAX  
NOTE.2) IF 'L' LEVEL TIME < T1, WARNING LAMP NOT BE ON.

EMTBE5055A

## D4DD, D4GA engine

### 1. Variable Intermittent Wiper

- In the state that the ignition switch is ON.
- In the state that the intermittent wiper switch is ON.

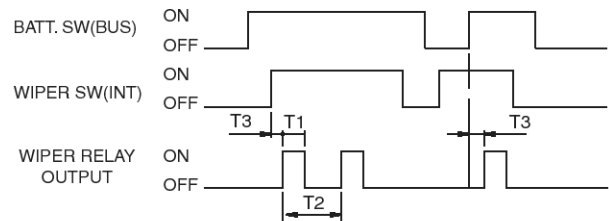

T1 : 0.6 ± 0.2 SEC  
T2 : 2.6 ± 10% SEC (AT VR=0) ~ 18 ± 10% SEC (AT VR=50 KΩ)  
T3 : 0.3 SEC MAX

SNBBE9010L

## 2. Washer related Wiper

- 1) At the ON of the ignition switch, if the washer switch is ON, after 1 sec, the wiper output is ON. When the washer switch input is within T3, after T4, the wiper output is OFF.
- 2) At the ON of the ignition switch, if the washer switch is ON, after 1 sec, the wiper output is ON. When the washer switch input is over T4, the washer switch is OFF and then the wiper output is ON for T2. After that, the washer switch is OFF.
- 3) This function is prior to the intermittent wiper function.

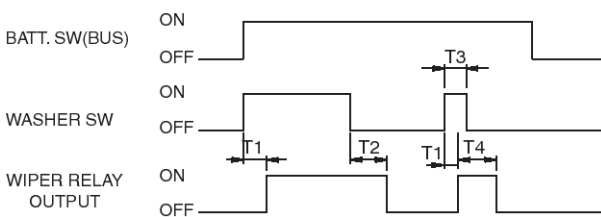

T1 : 0.6 ± 0.1 SEC  
 T2 : 3.7 ± 0.5 SEC(2 ~ 3 CYCLE WIPER ROTATION)  
 T3 : 0.2 ~ 0.6 SEC  
 T4 : 0.6 ± 0.2 SEC

SNBBE9011L

## 3. Central door lock control

- 1) It is possible to do LOCK/UNLOCK output of all doors according to the inside lock knob input of the driver or passenger.
- 2) There must be no error when the battery is connected. (when the battery is connected, there must be no lock output in states of KNOB LOCK or UNLOCK.)

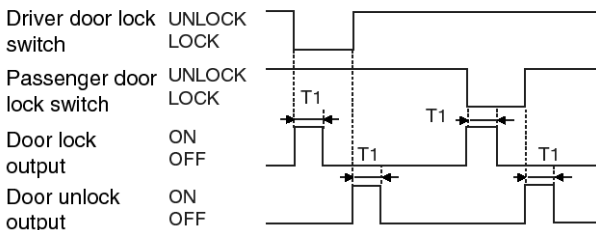

T1 : 0.5 ± 0.1 sec.

SUDBEA0025L

## 4. Ignition key reminder

- 1) When ACC is ON, open the driver's door and then if door is locked by pushing DOOR LOCK KNOB, should confirm actuator after the UNLOCK output for 1 second. If the LOCK is continuously maintained, it should be the UNLOCK output three times for 0.5 second.
- 2) Confirming the actuator during the three times of output, if there is the UNLOCK state, the next output will be stopped.
- 3) When the door is closed or ACC is off during the three times of output, the next output will be stopped.
- 4) Confirming the actuator during the three times of output, if it's continuously LOCKed, should maintain its state and then input the ACC. If there is any changes of driver door switch or driver door lock switch, it should make the reset.
- 5) When the door is open and ACC is ON in the LOCK state, UNLOCK should be outputted.
- 6) When the door is closed within 0.5 second in the LOCK state. Output UNLOCK for 1 second.
- 7) When the door state change from open to close and is locked within 0.5 second, output UNLOCK for 1 second.
- 8) If there is input of speed sensor(over 3~5 km/h), do not operate ignition key reminder function.
- 9) In case of the ACC OFF and ignition switch ON, do not operate key reminder function.

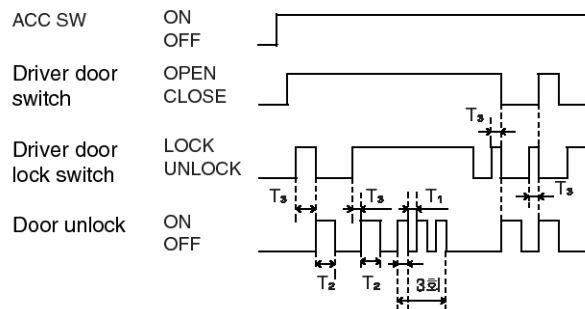

T1 : 0.5 ± 0.1 sec.  
 T2 : 1.0 ± 0.2 sec.  
 T3 : 0 sec. < T3 < 0.5 sec.

SUDBEA0026L

## 5. Ignition key hole illumination control

- 1) When the driver's door(or passenger's door) is opened and the ignition switch is OFF, the ignition key hole illumination turns on.
- 2) In the condition of 1), when the driver's door and passenger's door are closed, turn on the ignition key hole illumination for 20 seconds and then turn it off.
- 3) During the 1) and 2) operating, if ignition input is received, it should immediately turn off the ignition key hole illumination.

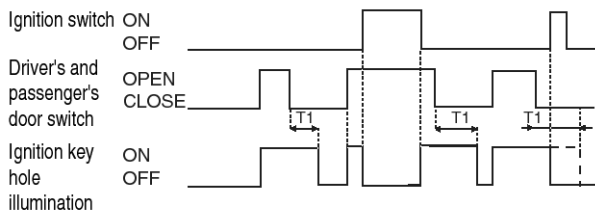

T1 : 20 ± 2 sec.

SUDBEA0027L

## 6. Power window timer

- 1) When ignition switch is ON, turn on the power window output.
- 2) When ignition switch is OFF, turn it off after maintaining the output for 30 seconds.
- 3) In the condition of 2), if the driver's door or passenger's door are opened and then closed, output should be OFF immediately.

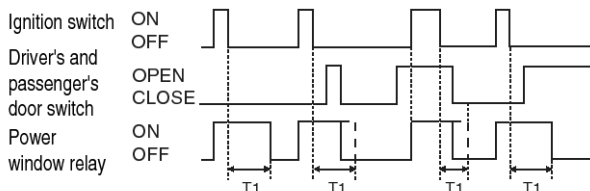

T1 : 30 ± 3 sec.

SUDBEA0028L

## 7. Seat belt warning timer

- 1) At the ON state of the ignition switch, if the seat belt is released, the seat belt warning lamp is output for T1.
- 2) If the ignition is OFF, the output of seat belt warning lamp is stopped.
- 3) While the seat belt warning lamp is output, if the seat belt switch is ON, the output of seat belt warning lamp is stopped immediately.
- 4) If the seat belt is fastened and then released in the state of IG ON, the warning lamp is again output.

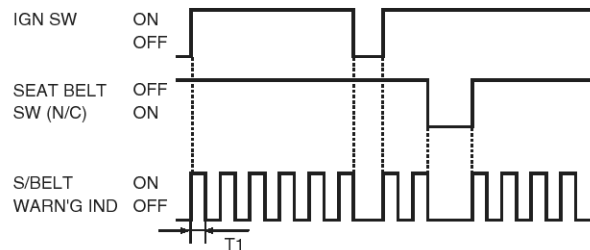

T1 : 0.3 ± 0.1 sec

SNBBE9012L

## 8. Heating mirror Timer

- 1) At the ON state of the ignition switch, if the heatwire switch is ON after the alternator "L" is ON, the heat-wire output is ON for T2.
- 2) During heat-wire output ON, if the heat-wire switch is ON again, the heat-wire output is OFF.
- 3) During heat-wire output ON, if the alternator "L" is OFF or the ignition is OFF, the heat-wire output is OFF.

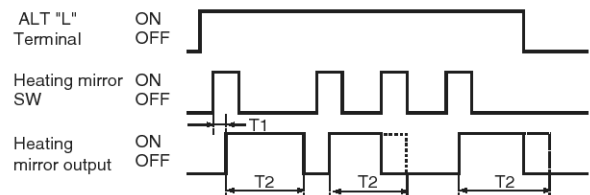

T1 : Max 60±20 msec

T2 : 15 ± 2 minute

SNBBE9013L

## 9. Tail auto cut

- 1) After ACC SW is On, if Tail SW is On, then ACC SW shall be OFF; when the driver's door is opened, then the Tail Lamp shall be OFF automatically.
- 2) Also, in the state that the ACC SW is ON, after the driver's door is opened, if the ACC SW is OFF, then the Tail Lamp shall be OFF automatically.
- 3) After the Auto Cut, if the Tail SW is ON after OFF again, the Tail Lamp shall be ON, and the Auto Cut function shall be canceled.
- 4) After the Auto Cut, when ACC SW is ON again, TAIL LAMP shall be ON, and the Auto Cut function shall be canceled.

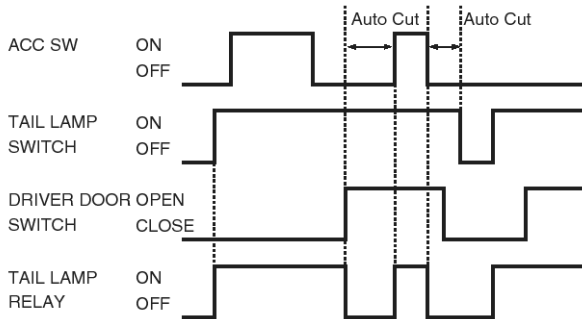

SNBBE9015L

## 10. Parking start warning

- 1) In the state that the ignition switch is ON, if the parking switch is ON and the speed of vehicle is maintained over  $7 \pm 1$  km/h for 1~2 seconds or more, then the warning relay should be operated.
- 2) In the state that the warning relay is operated, if the ignition switch(or the parking switch) is OFF or the speed of vehicle is maintained below 4 km/h, the warning relay should be stopped.

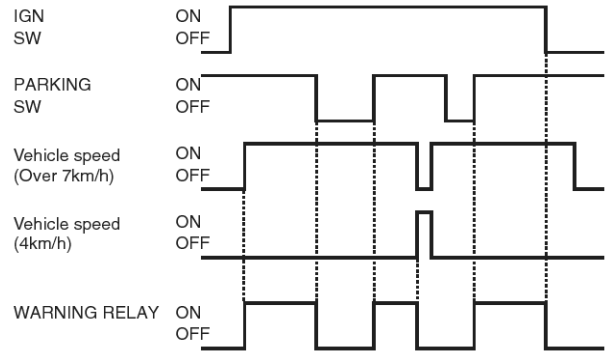

SNBBE9016L

## 11. Vehicle speed calibration

- 1) When IGN is ON, according to input PULSE, output the calibrated SPEED PULSE using the following form.

$$\text{OUTPUT PULSE} = \text{INPUT PULSE} \times K$$

$$K = [2\pi \times TR \times 5,096] / [1,000 \times AR \times N]$$

( if N = 1, fix the K = 1, when goods is delivered, initialize.)

- AR : REAR AXLE RATIO
- TR : TIRE DYNAMIC RADIUS, unit: (m)
- N : PULSE NUMBER PER ROTATION OF SENSOR

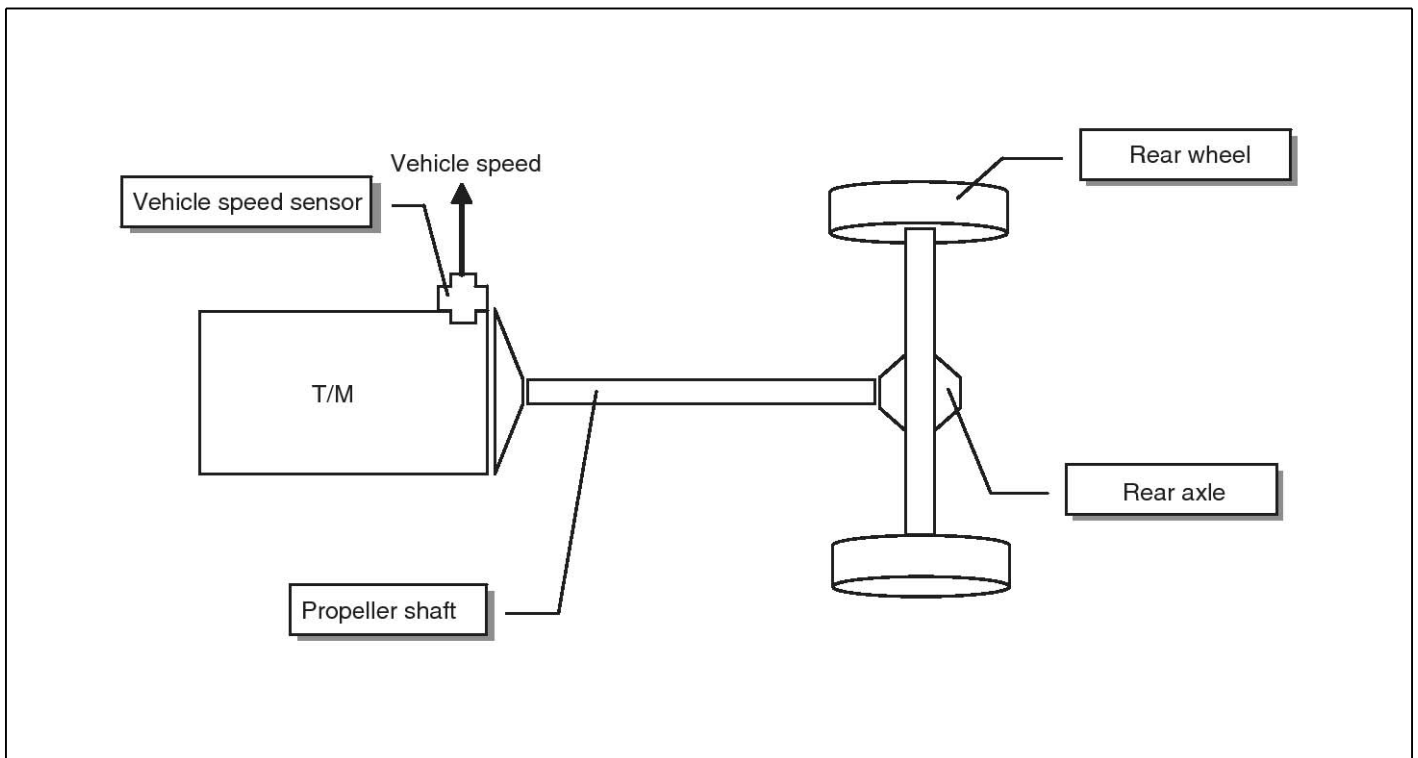

SPYBE7039L

## 2) Output Specifications of Speed Pulse

1. RISE TIME : 300us MAX
  2. FALL TIME : 200uS MAX
  3. LOAD MAX : 20mA MAX
  4. OUTPUT TYPE : OPEN COLLECTOR
  5. PULSE RATE : 5096 PULSE/km(+5%)
  6. OUTPUT RANGE : 0 - 227Hz
  7. DUTY RATIO : 50%(±15%)
- (The tolerance of output signal must be positive.)



3) when the IGN is OFF, CALIBRATED SPEED\_POS and CALIBRATED SPEED\_NEG maintain the reverse phase each other.

