

All information in this Owner's manual is current at the time of publication. However JAC reserves the right to make changes at any time so that our police of continual product improvement may be carried out.

This manual applies to all current JAC models equipped with 4DA1series engine explanation of option as well as standard equipment. As a result, you may find material in this manual that does not apply to your specific vehicle.

## Foreword

Thank you for choosing JAC. We are pleased to welcome you to the growing number of different people who drive JAC. The advanced engineering and high-quality construction of each JAC we build is something of which we are proud.

This Owner's Manual will introduce you the features and operation of your new vehicle. It is suggested that you read it carefully since the information it contains can contribute greatly to the satisfaction you receive from your new vehicle.

The manufacturer also recommends that all service and maintenance on your vehicle be performed by an authorized JAC dealer. JAC dealers are prepared to provide high-quality service, maintenance and any other assistance may be required.

ANHUI JIANGHUAI AUTOMOBILE CO., LTD.

May. 2008

## Contents

	Page
Importance .....	1
Locations of chassis number and engine number .....	2
Location of the vehicle nameplate .....	2
Overload .....	3
Information about new vehicles .....	5
Vehicle operation and management .....	7
Maintenance .....	7
Cabin tilting mechanism .....	8
Cabin lockup .....	10
Controller and instrument .....	13
Cabin heater, defroster, air conditioning .....	35
CD and Radio .....	43
Before driving .....	51
Operation of controllers .....	52
Daily check list for drivers .....	60

Driving .....	71
Preparations before startup .....	72
Engine startup .....	73
Before vehicle running .....	74
Engine stopping .....	76
Parking .....	77
Attention points for driving .....	78
Economic driving .....	83
Vehicle management and maintenance in winter .....	86
Running on ice or snow .....	88
In emergency cases .....	90
Repair and maintenance .....	101
Schedule of regular maintenance .....	104
Guide to maintenance .....	108
Recommended brands of lubricants and diesels .....	139
Lubrication .....	140
List lubrication point .....	141
Guide to lubrication .....	142
Technical specification .....	149

## Importance

The followings are very important for the correct management and economic use of JAC vehicles, and they shall be read carefully before use and maintenance.

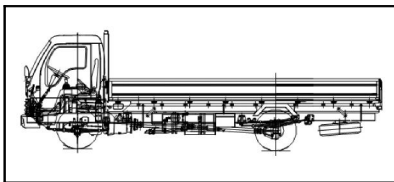

#### Locations of chassis number and engine number

Please note down the chassis number and engine number, so as to give them to the specified JAC maintenance stations in case of repair and maintenance.

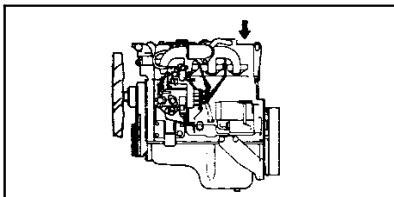

#### Chassis number

The chassis number, which is VIN code number, is stamped on the outer side of the right longeron end of the frame.

#### Engine number

The engine cylinder head is affixed with the engine tag, on which it is marked with information about the engine, such as its model, serial number, nominal horse power, rated engine speed, ex-works date, etc.

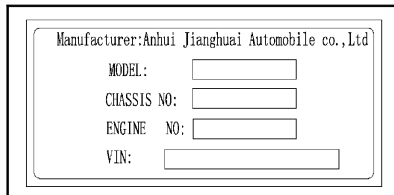

#### Location of the vehicle nameplate

The embossed number of VIN code for vehicle and Type II chassis is located on the outer side of the right longeron of the frame as well as, on the back side of the rear support of the rear leaf spring. Besides, an individual tablet of VIN

code is attached on the dashboard near the right column.

#### Overload

Overloading will shorten vehicle's service life, but also bring about potential risk to safe driving.

The loading mass must be limited to the specified range of the max. total mass for vehicle, and the load distributions on the front and rear shafts shall not be more than the carrying capacity of the vehicle shafts. Please refer to the technical specification sheet for the rated total mass value and shaft loading capacity.

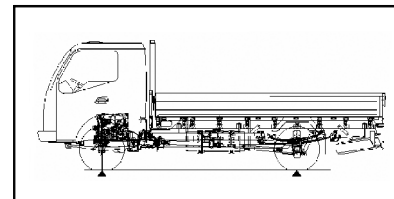

## Information about new vehicles

Careful driving and maintenance during the run-in period will play a crucial role in improvement of the performance and service life. So, the followings must be strictly abided by during the initial run-in period of 3000km:



1. During the initial 3000km driving, the vehicle speed shall not be more than 70% of the max. engine speed. Attention should be paid to the tachometer during driving to avoid engine over speed running.

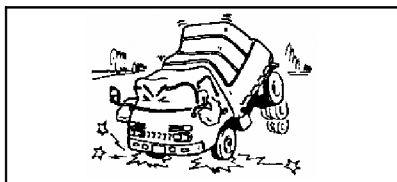

2. Try to avoid engine over speed running, abrupt startup or unnecessary emergency braking.

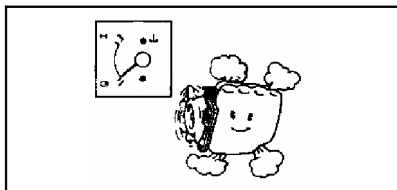

3. It is necessary to have the engine in idle running before driving each time, until it comes up to the normal working temperature.

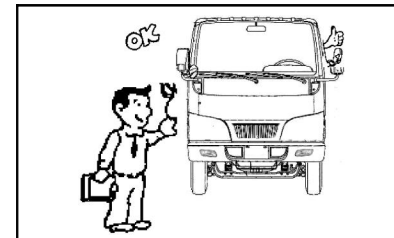

#### Vehicle operation and management

All the components and devices of the vehicles shall be checked according to the requirements in sections of "Controllers and instruments" and "Driving";

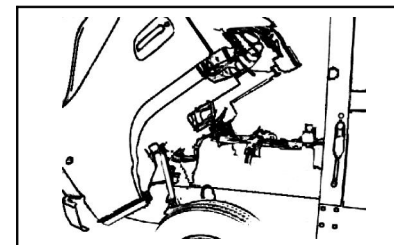

#### Maintenance

For driving safety, vehicle reliability and good performance, the requirements in the section "Maintenance" should be followed in check and adjustment.

#### Note:

1. No refitting or unauthorized installation of any equipment is allowed on JAC vehicles. Our Company will not be responsible for any losses due to unauthorized refitting or installation of any equipment!
2. If any problem occurs during the use of our products, make sure to have them sent to the specified JAC service station for maintenance; please see clearly the genuine parts of JAC vehicles if any parts need to be changed.

3. Correct run-in of new vehicle has much to do with longer service life, reliability and economy. It is specified that new

vehicle run-in mileage is 2500-3000km, with the max. speed not more than 80km/hour.

4. During your use of our products, please have maintenance in time referring to the "Instruction Manual" attached with the vehicle, in order to bring your vehicle's good performance into full play.

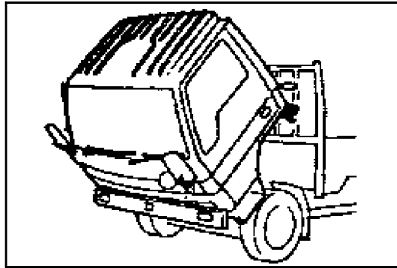

#### Cabin tilting mechanism

As shown in the figure, single cabin or one-and-half-row cabin can be tilted upward and forward by 40 degrees for easy maintenance.

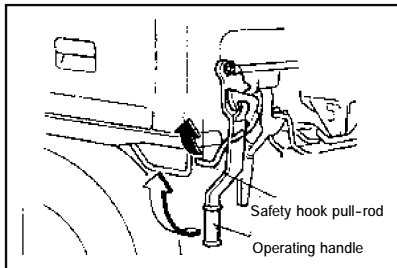

To begin tilting, turn the pulling support with left hand to pull out the safety hook tie bar, and pull outward the operating handle with right hand.

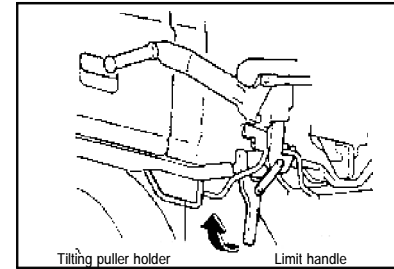

With the operating handle released, hold firm the tilting puller support with left hand, and pull the limit handle outward with right hand. The cabin will tilt forward for a certain degree after the handle opened.

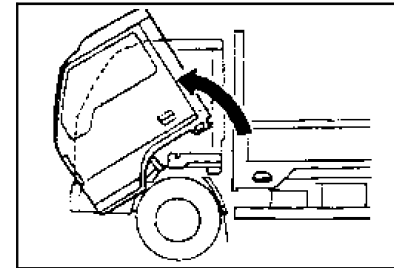

When the cabin tilts to a certain angle, hold the tilting puller support with right hand, continue tilting the cabin upward with force.

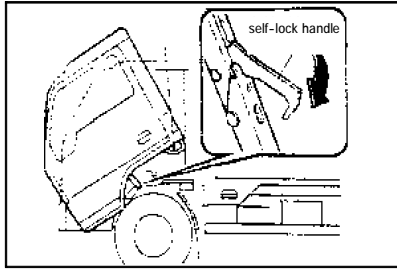

When the cabin tilts to a certain angle, the self-locking handle on the tilting support will automatically lock in by the spring tension, and the handle will support the cabin then.

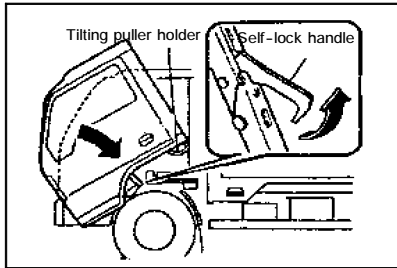

#### Cabin lockup

With left hand holding firmly the tilting puller support, open the self-lock handle upward and backward with right hand. The cabin will tilt downward by itself due to the deadweight.

Attention: Keep your head and hands away from under the cabin when it is tilting downward by itself.

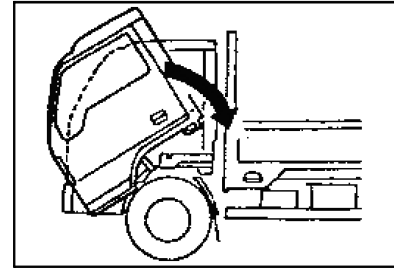

When going down to a certain angle, the cabin will slow down. Hold the tilting puller support and press it down with left hand, until the lock hook get engaged in the hook limit support on the frame.

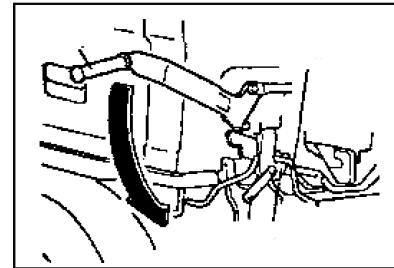

Then hold the operating handle with right hand and press it down, until the safety hook securely locks the operating handle.



## Controller and instrument

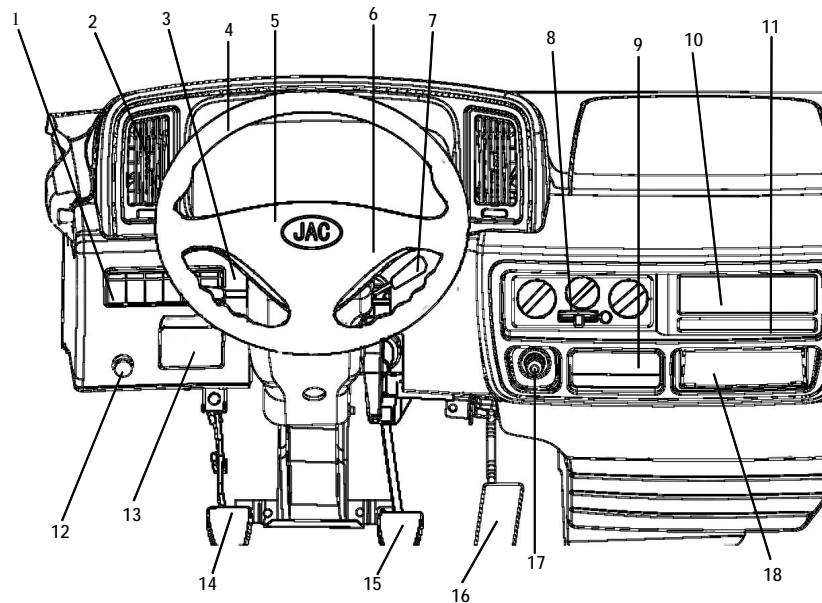

1. Switch
2. Instrument panel vent
3. Combined switch handle
4. Steering wheel
5. Instruments
6. Horn button
7. Windshield wiper/cleaner handle
8. Air conditioner switch
9. Ashtray
10. Radio
11. Tea cup holder
12. Manual accelerator knob
13. Ashtray
14. Clutch pedal
15. Brake pedal
16. Accelerator pedal
17. Cigarette lighter
18. Glove compartment

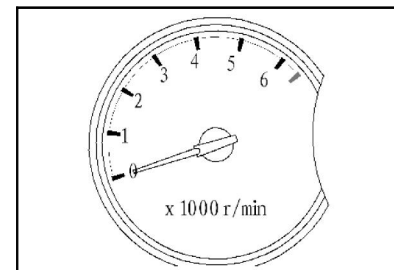

#### Tachometer

The tachometer indicates the engine 's round per minute. The red zone means the critical rpm.

When the tachometer hand is in the red zone of the scale plate, driving is not allowed. If a driver does not stop the vehicle when the tachometer hand is getting into the red zone, serious damage will occur to the engine.

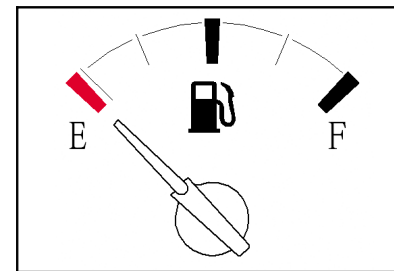

#### Fuel gauge

It indicates the present fuel level in the fuel tank, "F" stands for "Full", and "E" stands for "Empty".

Fuel tank should be always replenished in time to avoid fuel shortage during driving.

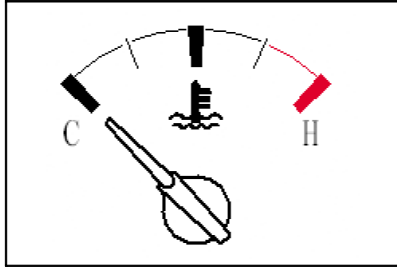

#### Temperature gauge

It shows the engine coolant temperature. If the hand is in the red zone when engine is running, it means the engine is overheat. Always pay attention to keeping the engine temperature at normal degrees.

#### Note:

There will be some difference between the actual temperature and the temp. reading of the tachometer due to the surrounding and driving conditions.

If the temperature inside and outside the vehicle is below -30 or above 70 degrees, it will bring about inexact temperature reading values.

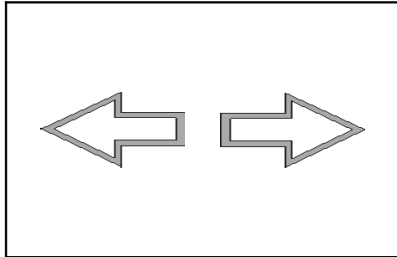

#### Turn signal indicator light (green)

When a turn signal lamp is flashing, its indicator light will flash on and off. If the flash is very short in interval, it is possible that the turn signal connected with it has some problem or maybe one of the bulbs is burnt down.

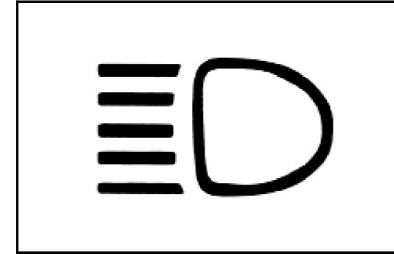

#### High beam indicator light (blue)

The indicator light will be on when the high beam is on.

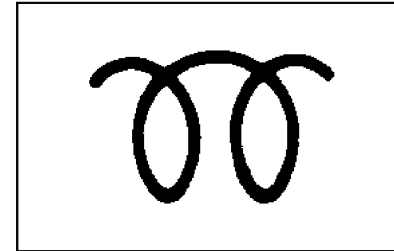

#### Diesel warm-up indicator light (light yellow)

When pressing the warm-up switch in "ON" position, this indicator light is on. The time when the indicator light is on depends on the water temperature.

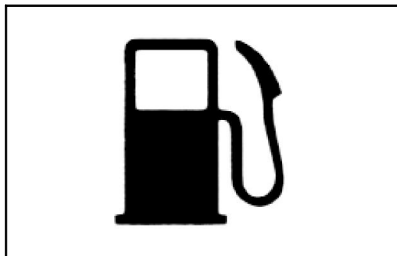

Low fuel level warning light (light yellow)

This light will be on when the fuel oil level is very low in the tank. Fuel oil should be added at once.

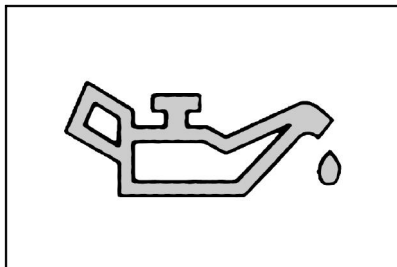

Oil pressure warning light (red)

It is on when the ignition switch is in "ON", and is off after the engine is started. If this light is on during engine running, stop the engine immediately, and get in touch with the nearest JAC vehicle dealer.

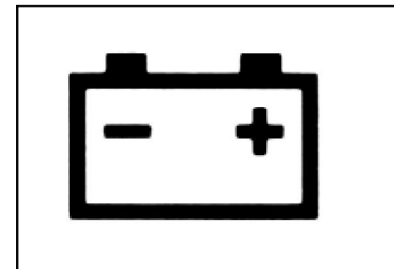

Charging warning light (red)

When the ignition switch is in "ON" position, this light is on, and becomes off after the engine is started. If the light remains on during the engine running, it means something wrong with the charging system. Check the V belt for any damage, and contact the nearest JAC vehicle dealer.

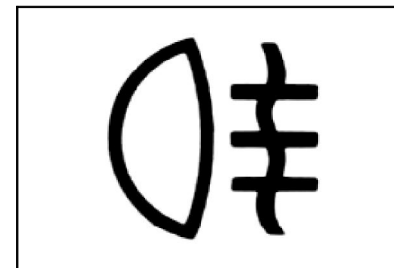

Rear fog light indicator light

This indicator light gets on when the rear fog light is turned on.

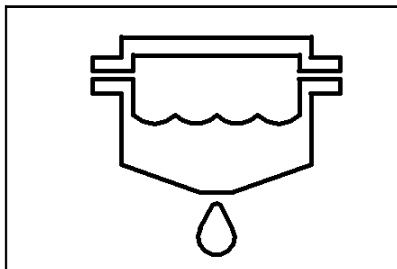

#### Water quantity indicator light of the fuel filter

When water in the oil/water separator reaches a dangerous level, the water quantity indicator light of the fuel filter is on. If the indicator light remains on during the engine running after it is on, it means that water in the oil/water separator should be drained out.

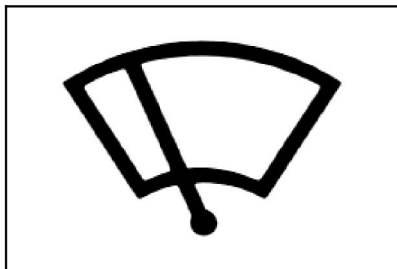

#### Windshield wiper working indication

Turning the operation handle in horizontal clockwise may control the windshield wiper. Turn the operation handle 12 degrees clockwise into the INT position, the windshield wiper will work intermittently in 5-10 seconds; turn the handle 12 degrees clockwise into the L0 position, the wiper will work at the low speed level; turn the handle further 12 degrees clockwise, and the wiper will work at high speed level; when the handle gets into the starting position, the wiper will automatically be turned off or reset.

#### Washer indication

The washer control button is at the end of the operation handle, and the windshield washer is installed near the right door and below the instrument panel. When the washer control button is pressed in, detergent (anti-freeze solution for winter time) will be injected out of the washer through the nozzles onto the windshield.

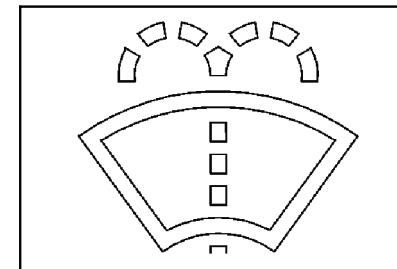

#### Danger warning switch

Pressing this switch, located in the lower left corner of the dashboard, will sound an alarm, at this moment all the turn signal lamps will be flashing, and have nothing to do with the positions where they are. Press it again, the switch will reset.

When vehicle meets with any danger that may cause traffic accident, this danger warning light shall be used in day and night to sound an alarm to other drivers.

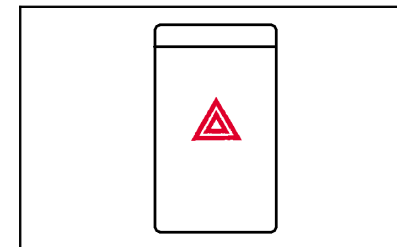

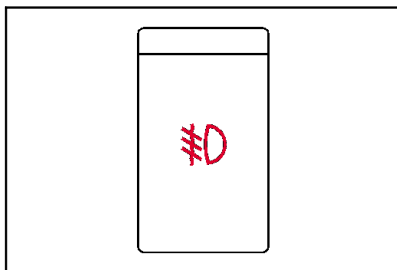

#### Fog light switch

When this switch, located in the lower left corner of the dashboard, is pressed, all the fog lights will be turned on, and one more press will have a reset.

When vehicle meets with any danger that may cause traffic accident, this danger warning light shall be used in day and night to sound an alarm to other drivers.

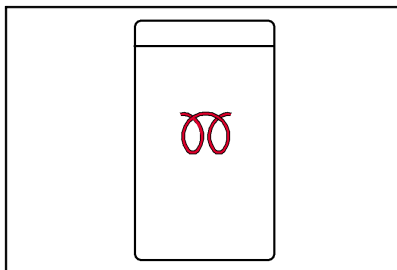

#### Preheating switch

When this switch, located in the lower left corner of the dashboard, is pressed and held down in "ON" position, the indicator light is on. The holding down time is dependent on the water temperature, normally about 30 seconds.

If the ambient temperature is below zero or even lower, press this preheating switch before starting the vehicle in order to raise the inlet air temperature for the engine to achieve smooth startup.

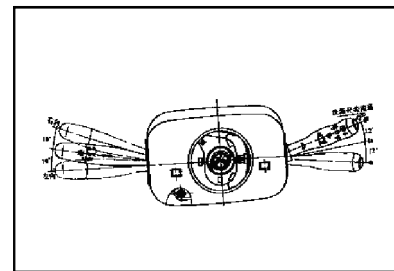

#### Combination switch

Located below the steering wheel, it consists of steering shaft lock seat, ignition startup lock and the ignition switch.

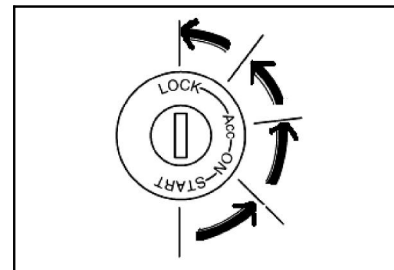

#### Ignition switch

Located to the right of the combination switch, the ignition switch serves as 4 functions like LOCK, ACC, ON and START. See left Fig. for the positions shown. Insert the key into LOCK position, the ignition switch is powered on and unlock the steering gear. Turn the key clockwise into ACC position, the auxiliary devices circuits are powered on, such as radio and tape player, etc. Turn the key to ON position, the instruments circuits are powered on. Go on to turn the key to START position, the engine is started. Release the key as soon as the engine is started, and the key will go back to ON position under the spring force.

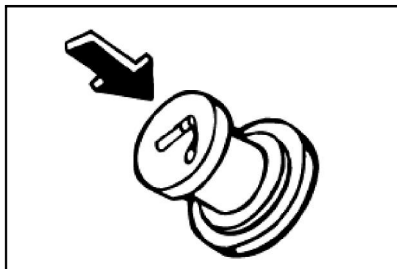

#### Cigarette lighter

It is in the lower right to the steering wheel. If you want to use it, press it inward for about 15 seconds, with the ignition switch key in "ON" position, and then release it. It will heat up enough for use before automatically going back to its normal position.

1. Do not hold on the cigarette lighter after it is pushed in, otherwise it will be overheated and may cause fire.
2. If the cigarette lighter fails to auto come back to its normal position in 18 seconds, it means it has something wrong, and you must manually pull it back to its normal position.
3. Do not leave the cabin with the cigarette lighter pushed in, otherwise it may cause unexpected fire.
4. A deformed cigarette lighter cannot correctly recoil to its original position. If it is found deformed, please replace it with a true JAC spare part.

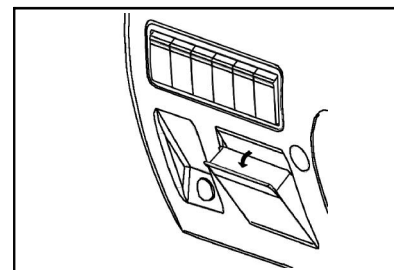
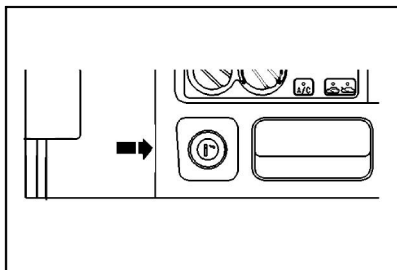

#### Left ashtray

Pull out the ashtray for use. Pull out the ashtray further while pressing the positioning spring, and it may be taken out for cleaning purpose. Turn back and close the ashtray after use, otherwise the still burning cigarette may ignite other butts and cause possible fire.

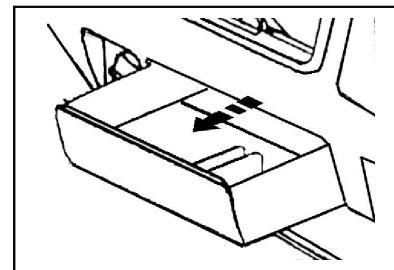

#### Right ashtray

Pull out the ashtray for use. Pull out the ashtray further while pressing the positioning spring, and it may be taken out for cleaning purpose. Turn back and close the ashtray after use, otherwise the still burning cigarette may ignite other butts and cause possible fire.

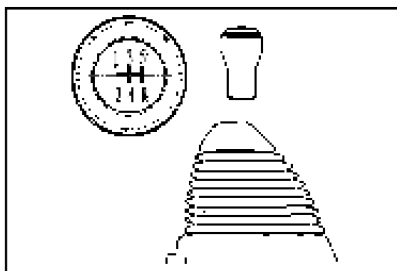

#### Controller on the floor pan

##### Gearshift lever

Each time before you shift the gears, you should first step on the clutch pedal to the end. The gear shift chart is on the top of the gearshift lever. With the key in "ON" position, the backing indicator light will be on if the gearshift lever is moved to the Reverse gear position.

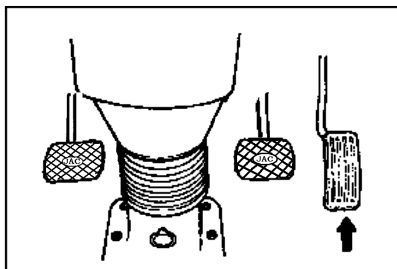

#### Accelerator pedal

To avoid unnecessary fuel consumption, operate the accelerator pedal in a proper and balanced way according to the need.

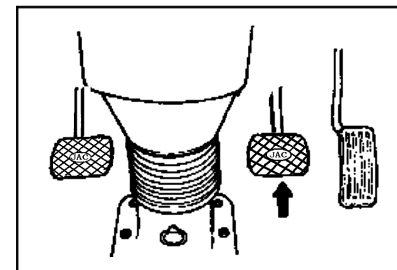

#### Brake pedal

To avoid sharp braking, the brake pedal should be operated smoothly. When driving along a down slope, you should use the foot brake pedal now and then while using the vent as auxiliary braking means.

If engine cut-out occurs during running, the brake booster will not fully function, and the braking effect will be lowered.

In such a case, step on the brake pedal with force to have enough braking effect.

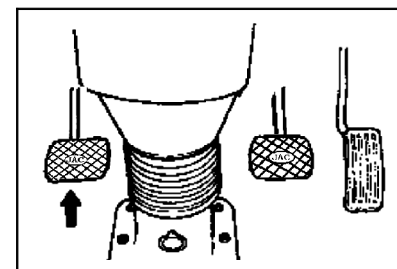

#### Clutch pedal

The clutch pedal must be stepped on to the end when it is used, otherwise the gears in the gearbox will give out friction noises, and the clutch-plate will be worn out soon.

Foot off the clutch pedal when not using it.



#### Others

##### Glove box

Pull out and the upper part of the glove compartment will open.  
The glove compartment should be closed during driving to avoid any articles from bouncing out.

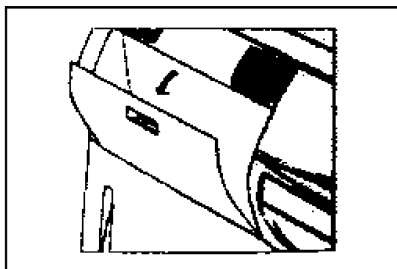

##### Sun visor

If the head-on sunshine is dazzling, the sun visor can be lowered down to shield the sun light. This sun visor may also be hooked off and turned to the side for use.

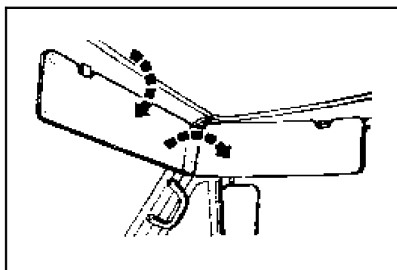

##### Ceiling light—rearview mirror

No matter which position the startup key is in, the ceiling light in the cabin can be turned on or off.

- ① "OFF" position: this light is in off state.
- ② "Door" position: when the side door of the cabin is opened, this light will be on.
- ③ "Powered" position: no matter what kind of state the door is in, this light will be on.

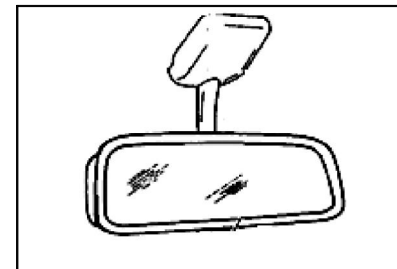

##### Standby water tank for radiator

The standby water tank for the radiator is installed on the right side of the frame.

Check the cooling water level and make up cooling water at the standby water tank. Do not open the injection port cover at the radiator unless needed particularly. See the "Maintenance" for details.

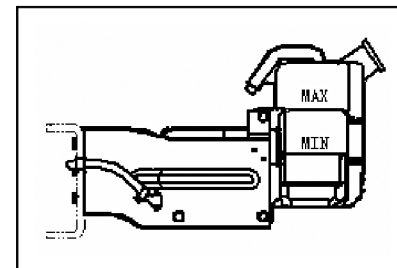

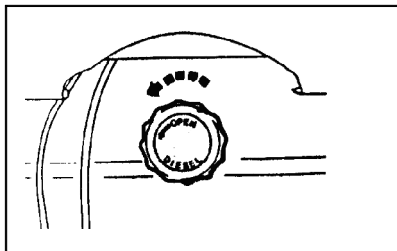

#### Fuel tank cap

The fuel tank cap is on top of the fuel tank, and it can be screwed off counter-clockwise.

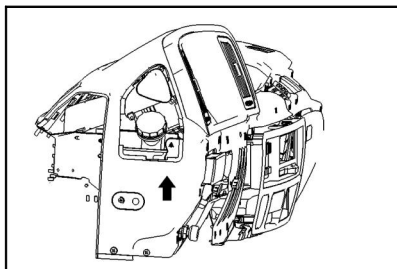

#### Fluid reservoir for brake and clutch

The fluid reservoir is installed by the instrument panel near the driver side.

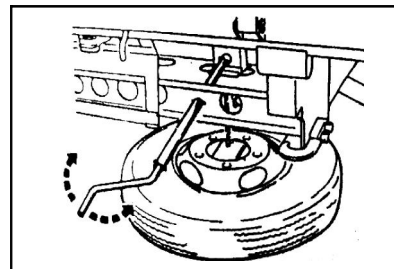

#### Spare tire hanger

The spare tire is fastened to back of the frame. To lower down the spare tire, insert the handle into the hole in the rear cross beam to connect it with the snap-lock, and then turn the handle counterclockwise.

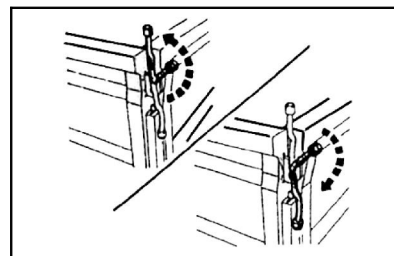

#### How to open and close the rear board

Turn the handles on the right and left sides both upward for 180 degrees, and the rear board can be released. To closed it, turn the board close first before turning down the handles to fasten it.

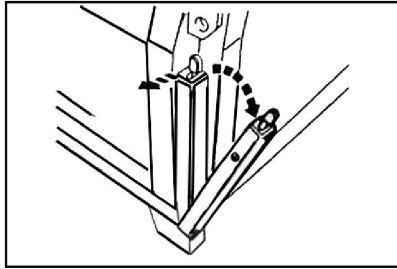

#### Right and left side boards

1. Release the lock knuckles of the rear board.
2. Move the fastened handle leftward before putting down the vertical lock outwards to release it.

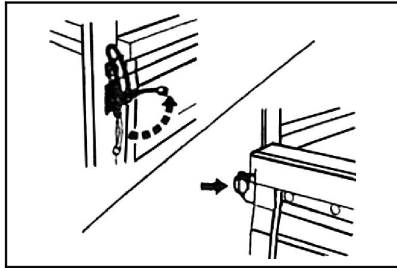

3. Lift up the hook handle on the front end of the side board to release the front hook.
4. At this time, the front end of the side board is still fastened by the board clamp. Pull out the board clamp with force to let free the side board.
5. To close the side board, securely lock up the front end of side board with the hook handle, and put it into the vertical lock of the rear board before fastening it with the handle.

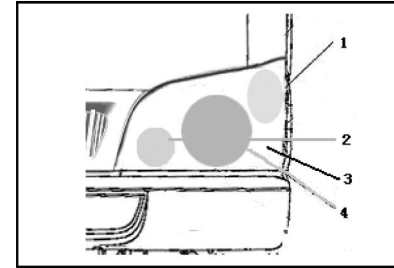

#### Outer lights

##### Front:

1. Front turn signal lamps;
2. Fog light;
3. Front side-marker light;
4. Headlight.

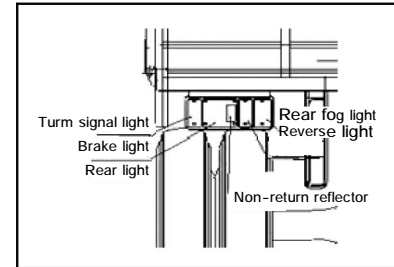

##### Rear:

The rear light set is installed in the position shown on the left figure, with the following:

1. Back-up light;
2. Turn signal lights;
3. Brake lights;
4. Rear side-marker light;
5. After-reversion reflector.

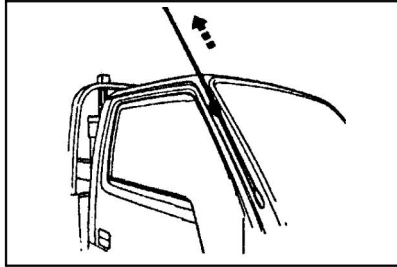

Antenna:

Please pull out the antenna if a better sensitivity of radio is desired.

The antenna should be retracted if the vehicle is to be parked in a garage lower than a house or to be washed.

## Cabin heater, defroster, air conditioning

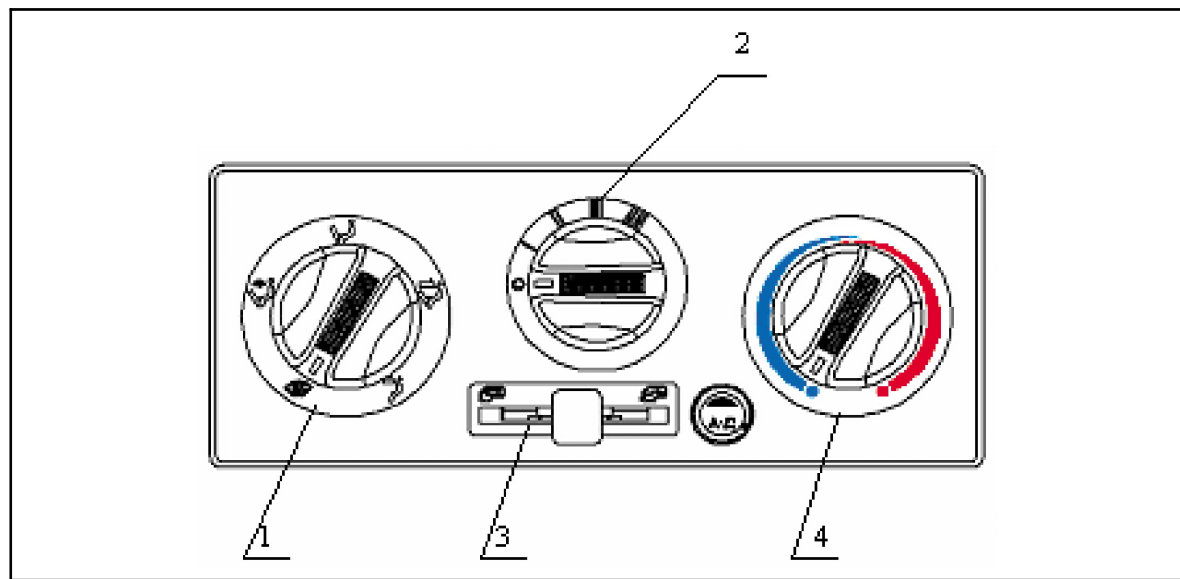

1. Temp. control knob  
2. Fan flow knob

3. Air inlet control bar  
4. Air outlet control knob

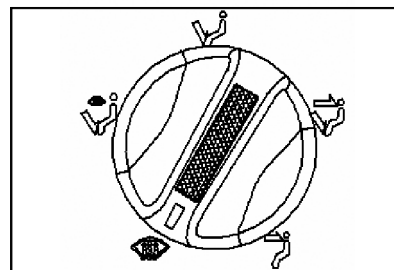

Air outlet control knob

Use different knobs to regulate the air from the heater, defroster and the air conditioner, or the air flow out of the ventilation outlet.

- ① Plane air outlet
- ② Dual planes
- ③ Bottom air outlets
- ④ Bottom air outlet and defroster
- ⑤ Defroster

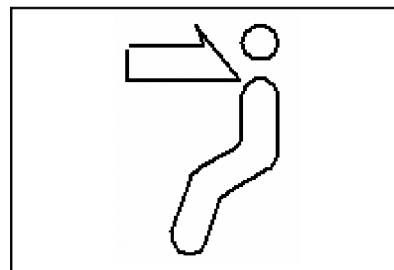

Plane air outlet

Air is regulated when it passes the system, and is vented from the upper air outlet. This position is used for most of the air conditioning cases.

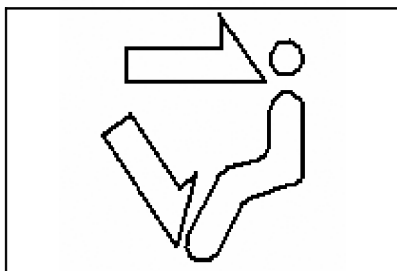

#### Dual planes

Air is regulated and discharged from the upper air outlet and floor air outlet. The air out of the floor air outlet is warmer than that from the upper air outlet in the range of dual planes. But when the temperature control knob is turned to "Warmest" or "Coldest", the air from the floor air outlet is the same as that from the upper air outlet.

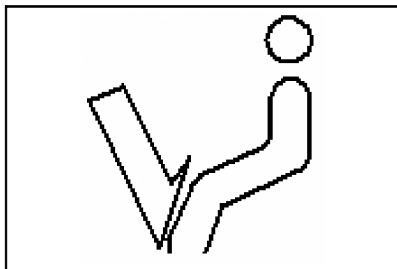

#### Bottom air outlet

Air is discharged from the bottom air outlet.

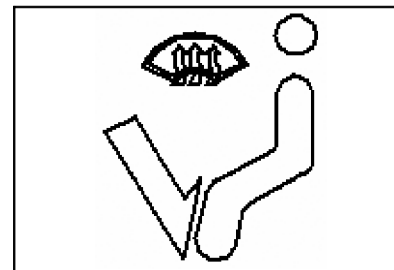

#### Bottom air outlet and defroster

Air is discharged from the bottom air outlet, and small part of air is discharged from the air outlets of defroster and the side window defroster.

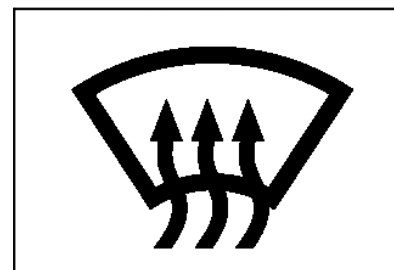

#### Defroster

Air is regulated and discharged from the air outlet of the defroster; small part of air is discharged from the side-window defrosting air outlet. This position is only recommended for heavy fog and freezing.

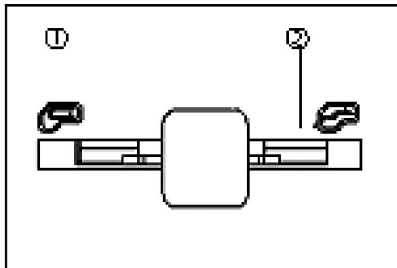

Move this selection rod leftward or rightward to control input of ② ambient air and the circulation of the inner air.

Note: Only prolonged circulation of the inner air will make the windshield blurred. For the sake of good ventilation, it is better to exchange with the air from outside.

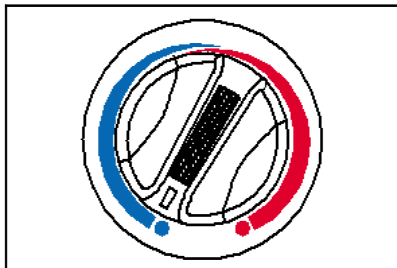

#### Temperature control knob

Turning this control knob may control the inside temperature within the range of temperatures indicated on the instrument panel.

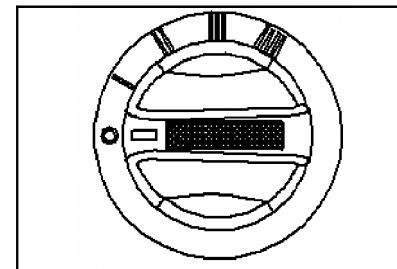

#### Fan air flow knob

Turn the knob as per the following to control the air output.

OFF: Fan is powered off.

- 1.....Fan is set in low speed range
- 2.....Fan is set in medium to low speed range
- 3.....Fan is set in medium to high speed range
- 4.....Fan is set in high speed range

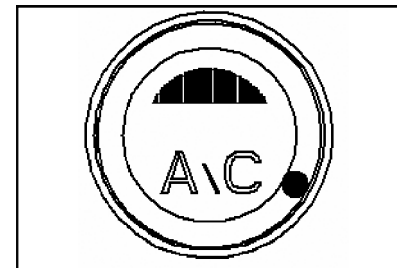

#### Air conditioner switch

Press the "A/C" switch to put the air conditioning system into operation. The LCD in the switch will be on when the system is under operation. Press this switch again ,and the air conditioning system is switched off.

If the fan control rod is in off position, instead of any position in the range of fan speed settings, the system can not be put into operation.

## CD and Radio



CD



Panel function descriptions

- |                               |                               |
|-------------------------------|-------------------------------|
| 1. <b>1</b> .....Preset key 1 | 2. <b>2</b> .....Preset key 2 |
| 3. <b>3</b> .....Preset key 3 | 4. <b>4</b> .....Preset key 4 |
| 5. <b>5</b> .....Preset key 5 | 6. <b>6</b> .....Preset key 6 |
7. SOUND .....sound effect mode, sound effect key  
 8. Short press: power on; Long press: power off.  
 9. ....Monitor  
 10. ....Volume knob. Press up/down to adjust the sound volume; regulate the frequency mode selected.  
 11. ....OURCE.....Short press: select the sound source (CD).  
 BAND.....Short press: select the wave band  
 AST..... Long press: auto storage(CD) .....Short press: auto storage(cassette)  
 12. ◀▶.....Attuning mode(short press: auto search upward / downward; long press: manual search upward/downward  
 13. ▶.....fast forward  
 14. ◀.....fast backward  
 15. ▲.....Eject key(CD)  
 16. ....Disc chamber/cassette ch-amber

### Acoustic apparatus

on/off

Press for start, and press over 2 seconds and the master unit is turned off.

Sound volume

Press - or + to adjust the volume.

Mute

Short press key to enable/disable mute mode.

Sound effect mode

Select the desired type of sound effect as per your personal preference. Press SOUND key to select BASS-TRE, and press the sound volume key +/- to adjust the type of sound effect.

RND\*.....CD random play on/off

RPT\*.....CD repeat on/off

SCN\*...CD music scanning

- 
- BASS-TRE; auto setting the BASS or TRE of the apparatus.
  - FLAT; Original
  - JASS; Jazz music
  - VOCAL; Speech
  - POP; pop music
  - CLSSIC; classical music
  - ROCK; rock & roll music

### Acoustic mode setting

Press SOUND key to select the item you want to adjust.

Again press +/- key to adjust the item selected.

Five seconds later the screen turns back to the previous mode.

Only with BASS-TRE selected as the sound effect mode, can BASS and TRE settings be adjusted.

- 
- Sound effect type, (BASS-TRE, FLAT, JASS, VOCAL, POP, CLSSIC, ROCK)
  - BASS; deep sounding
  - TREBLE; high pitch
  - BLANCE; balance on left and right
  - BLANCE; balance on left and right
  - BLANCE; balance on left and right

- 
- Radio
  - CD/Cassette\*

### Sound source selection

Press SOURCE key to select the desired sound source.

When a cassette is inserted in, the sound source will be automatically changed from radio to cassette play. Please take out cassette when you want to listen to radio, so as to protect the unit.

Radio

Wave band

Press the BAND key to select the wave band desired.



**Auto search**

Press Button ◀ or ▶ to auto search the radio stations.

Press ◀ ◀ or ▶ ▶ key tune to the radio stations of low frequency, or press key ▶ to tune to the radio stations of high frequency.

You may press the same key if you want to search for another radio station.

**Manual search (if you know the frequency of the radio station you need)**

Long press Key ◀ or ▶ for about 2 seconds before entry of manual search. Press Key ◀ for search of low-frequency radio stations.

Press ▶ for search of high frequency radio stations (If there is no search in 5 seconds, the system will return to the previous operation state).

**Preselected radio stations (stored or preselected)**

**Manual storage of radio stations in preset keys**

Use the preset keys (1-6) to store 6 radio stations in each wave band. Tune to the radio station desired, and press the preset key needed (1-6) for 2 seconds at least, and the radio station available now can be stored into this preset key.

**Call back the presetting**

Press the preset key needed (1-6), the preset radio station will be called out.

**Auto storage of radio stations**

This function can auto store 6 FM radio stations(with most powerful signals) in the FMAST wave band or 6 MW(AM) radio stations

(With most powerful signals) in the MW (AM) wave band. When this auto storage function is used for new radio stations, new radio stations will take the place of those stored previously in FMST or MW (AM)AST waveband.

Press AST key to activate the auto storage function.

The main unit gives out "beep" before muteness.

"Beep" can be heard after the storage is over.

Sometimes less than 6 radio stations can be found.

**CD play \*(CD)**

Put the disc (printed side up) into the disc chamber and the play begins.

If a disc is already in the chamber, press the SOURCE key to select CD as the source. Play begins.

**Previous/next music**

Press Key 3 or 4 to select the music desired. Play begins with the music selected.

**Music fast forward/backward**

Press Key 3 for more than 2 seconds to drive the disc fast forward or fast backward. Release the key and the normal play will go on.

**Random play**

Press RND key for at least 2 seconds to activate/quit Random play.

**Repeated play**

Repeat the play of the present music. Press RPT key for at least 2 seconds to activate/quit the Repeated play.

**Music scan**

This function can scan each of the music pieces for several seconds. Press the SCN key to activate/quit the Music scan

function.

Disc eject (CD)

Press the ▲ key to eject the disc.

Change over the display mode(CD)

Press FUNC key to select the DIS menu.

Press the DIS key and you may have display changeover among the music number/played time, total music time/total music numbers, sound effect mode and clock mode.

Display mode changeover(multi-disc CD)

Press FUNC key to select the DIS menu.

Press the DIS key and you may have display changeover among the music number/played time, total music time/total music numbers, sound effect mode and clock mode.

Troubleshooting

If you find some of the functions of the acoustic apparatus in your vehicle do not work any more, you'd better do a careful reading of the instructions in the manual before having it repaired, and do a check against the list below. And this will be helpful to you in troubleshooting. If the trouble cannot be removed still, please send it to the maintenance station for repair. Do not dismantle and repair it by yourself.

## Before driving

Proper maintenance and driving can prolong the vehicle service life, but also improve the economy of fuel consumption. Please drive your vehicle carefully.

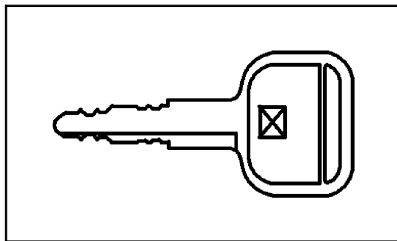

#### Operation of controllers

##### Key

This key is used to operate the startup switch and door lock. Each key is carved with a number, and kept in a safe place. Do not leave it in the vehicle.

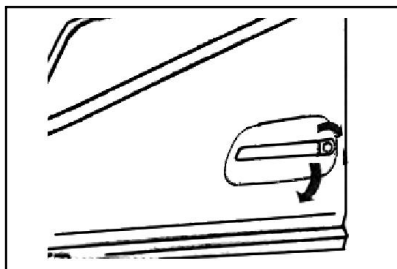

##### Outer door-handle

Pull outward the outer door-handle and the door is opened.

Insert the startup switch key into the door lock and take a turn, the door can be locked.

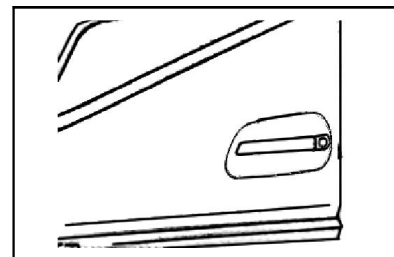

##### Door lock (outside)

The vehicle doors can be locked, from outside without the key, by pressing the lock pin (on the inside of the door) in "LOCK" position, and pull outward the outer door-handle, and the door is locked.

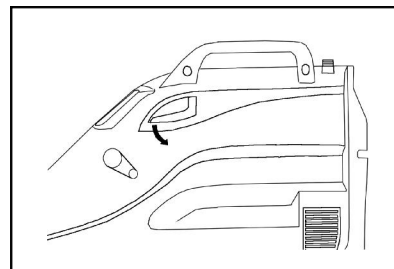

##### Inner door-handle

Pull out the inner door-handle and the door is opened.

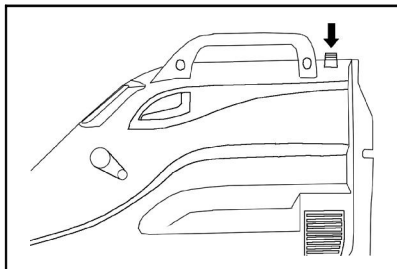

#### Door lock(inside)

Close the door, press in the lock pin in position, and the door can be locked.  
Before driving, make sure that the doors are securely closed and locked, especially in case of kids sitting inside.

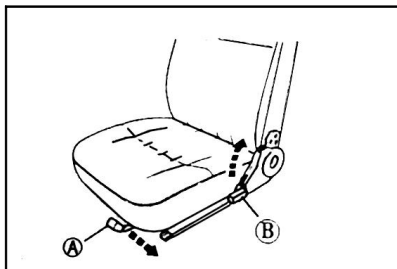

#### Driver's seat

Adjusting rod A: move this adjusting rod to the left to slide the chair back and forth.  
B: Pull this adjusting rod up to adjust the chair back.  
Do not adjust the driver's seat, because any sudden move may bring the vehicle out of the control by the driver.

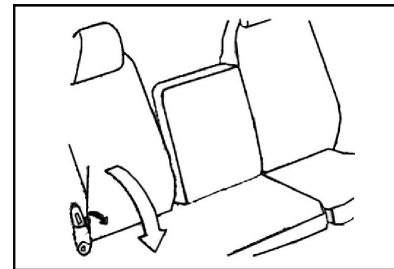

Pull the back tilting handle, the co driver's chair back tilts down; lift the back to turn over backward and the back will automatically comes back to its normal position and gets locked automatically.  
Before driving,make sure that the doors are securely closed and locked,especially in case of kids sitting inside.

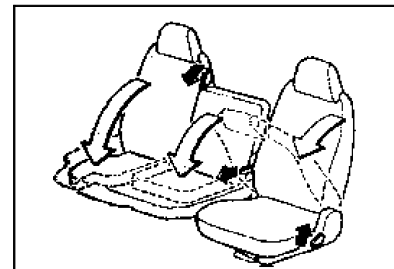

Pull the auxiliary back tilting handle, the aux. back may lean down; lift the back and turn it over backward, and the back will automatically comes back to its normal position and gets locked automatically.

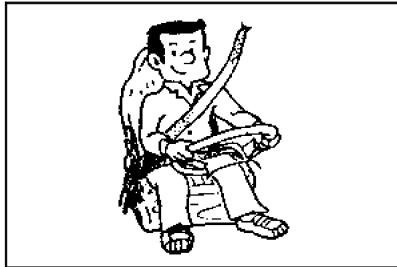

seat belt

#### Front seat belt

In your vehicle, there is a seat belt, supported at 3 pivots. It can be used as waist belt as well as shoulder belt.

Please refer to the following information about the seat belt use for correct abidance by.

1. Adjust the seat to the comfortable position for the driver, with the chair back against the driver's body.

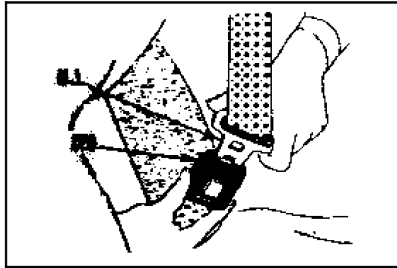

2. Holding the seat belt by its snap piece (L), pull tight the seat belt across the body. Then pull the snap piece and the belt to the snap position (B), and insert it into the opening, till a "click" is heard.

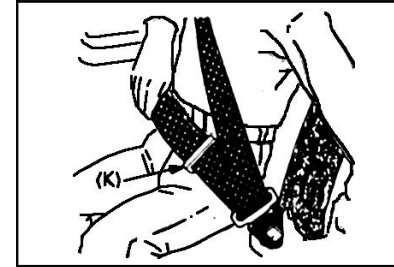

It is important to have the seat belt secured against the body and lowered in position, because at the moment of traffic collision, the force from the waist belt will be distributed around the pelvis major instead of the belly. If the seat belt is not tightened, serious injury will occur in case of traffic accident.

The seat belt across the waist should be pushed down as close as possible to the pelvis major. Then, pull tight the shoulder belt that goes through the snap opening, to have the seat belt stay against the waist. In this way, the driver will less likely slip off the belt in case of traffic accident. If the positioning buckles (K) bulge again st the snap piece when pulling the belt, the positioning buckle should be moved towards the door near the seat.



To avoid injury from traffic accident, it is forbidden for 2 persons to share one seat belt at the same time. Try to avoid the seat belt damage due to twist or clamp in the door.

The shoulder seat belt for the front seat is provided with so-called "Vehicle pick-off retractor". It is so designed that the safety belt gets tightened only in case of emergency braking or collision, while the belt can slide freely along with the user during the rest of time. The seat belt can be released if the button amid the snap is pressed.

When not used, the seat belt can be rolled into the retractor for storage. If needed, the positioning buckle on the belt can be moved to have the seat belt fully rolled into the retractor. At this time the snap piece is hung at the door column within reach.

#### Inspection and maintenance of the seat belt

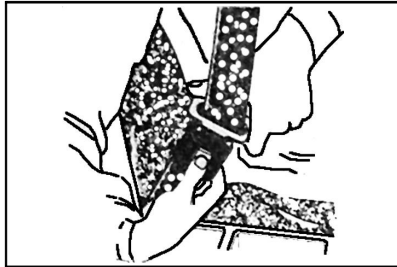

- \* Check the seat belt, snap buckle, snap piece and retraction device on a regular basis. Check the support for any damage, to avoid decrease of its safety effect.
- \* Keep sharp-edged articles away from the seat belt to avoid any possible damage to the belt.
- \* Change the seat belt if cuts, cracks, slackness or damaged by collision load.
- \* Check if the fixing bolts for the support are securely tightened in the floor pan.
- \* Change any parts that are found with problems.
- \* Keep the seat belt clean and dry.
- \* Wash it only with weak alkaline soapy solution and warm water.
- \* The seat belt should not be bleached and dyed, or its safety strength will be weakened.

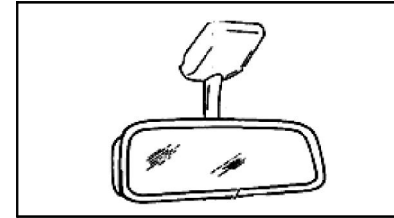

#### Mirror

##### Interior rear-view mirror

The rear-view mirror can be moved back and forth or left and right for adjustment.

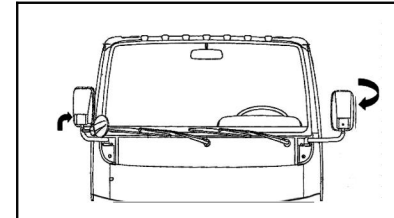

#### Door mirrors

The door mirrors on the left and right sides can be adjusted manually in the arrow direction.

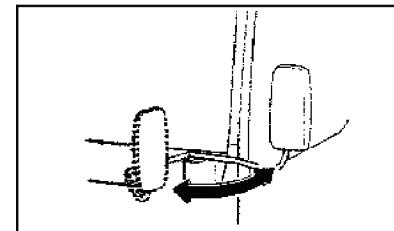



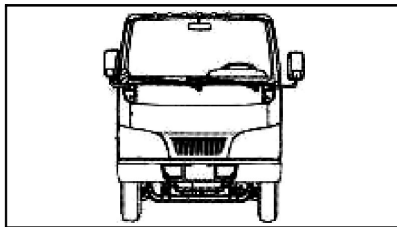

Daily check list for drivers  
Drivers should do the daily check of the following to ensure safe and reliable operability of the vehicles.  
(Please refer to the Section" Maintenance" for correct checking steps)

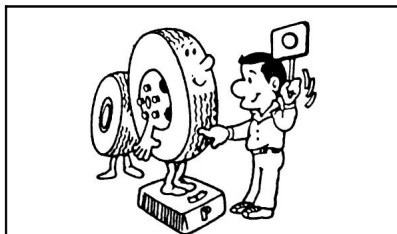

Exterior

1. Check the tires for correct pressures, any damage or leakage.

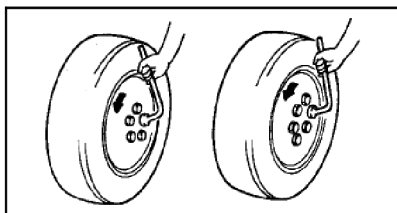

2. Check each of the tires for any looseness.

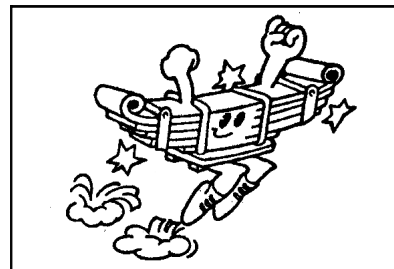

3. Check the leaf springs and lifting lug pins for any damage.

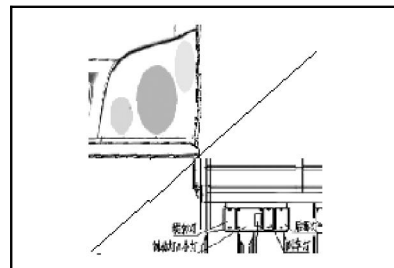

4. Check if all the lights work normally.

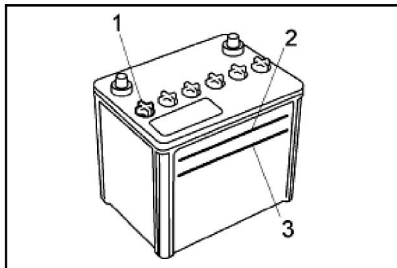

5. Check if the battery electrolyte is OK or not.  
The normal level should be between "MIN" and "MAX".  
(Note: 1.blind plug; 2.MAX; 3.MIN)

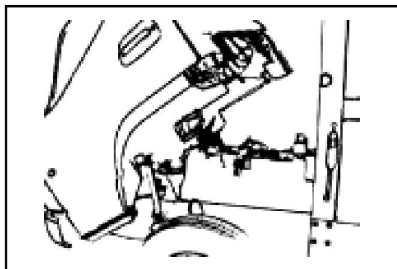

6. Check for any leakage of the engine oil, cooling water, fuel oil,  
and brake fluid.

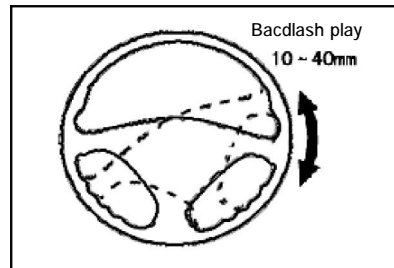

Cabin

1. Check if the backlash play of the steering wheel is normal or loose.

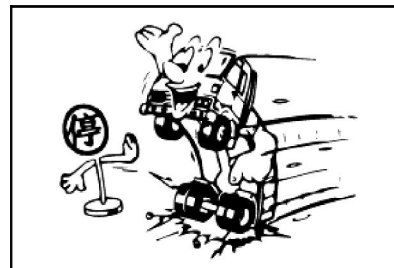

2. Check the braking effect of the brake.  
Step on the brake pedal to see if the brake response time and braking effect  
are OK.



3. Check the windshield wiper and washer  
Prior to check, wash the windshield first. Then eject the cleaning liquid to see if it is correctly sprayed onto the glass, and make sure the wiper works normally at each of the modes.

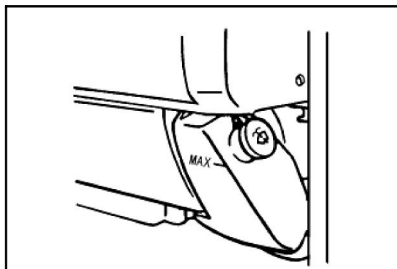

4. Check the cleaning liquid storage.  
Check the cleaning liquid storage for the windshield, and add more liquid as needed.

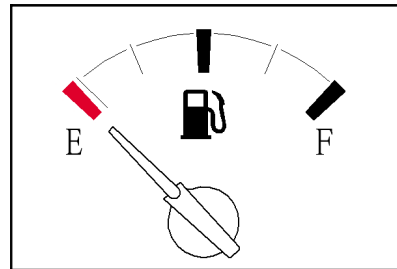

5. Check if the oil level in the fuel tank, indicated by the fuel gauge, is normal or not.

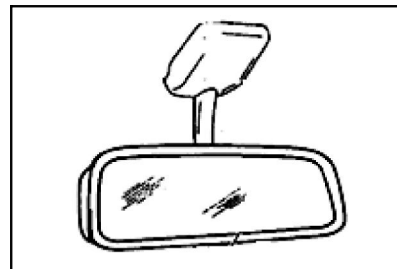

6. Check if all the door mirrors and rear-view mirror are correct in angles.

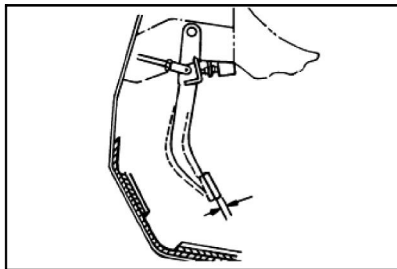

7. Check if the clutch pedal has correct back play and height, and if it works OK.

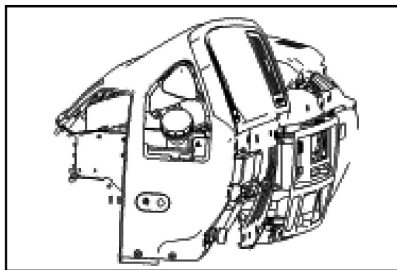

8. Check if the clutch fluid level and the brake fluid level in the fluid reservoir are OK or not.

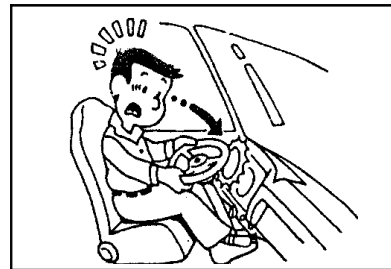

9. Check if all the instruments and indicator lights work correctly.

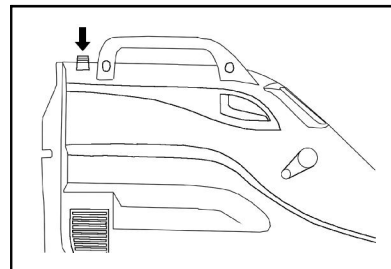

10. Check if the door locking system works normally.

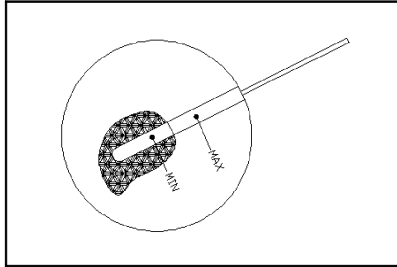

### Engine compartment

1. Check if the engine oil level is OK.

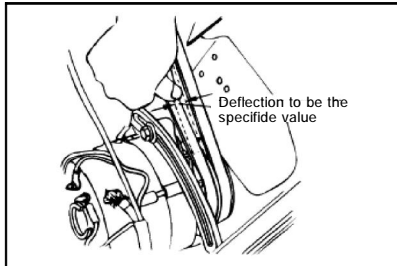

2. Check if the fan belt tension is correct.

The fan belt tension should be often checked, in the following way: pressing the belt with 70-100N force to see if its deflection is the specified value. If the fan belt is over-tightened, the pump bearing and the alternator bearings will be damaged too early; if it is too loose, then belt will have slip, and the cooling effect will go down, hence, the engine will be overheated.

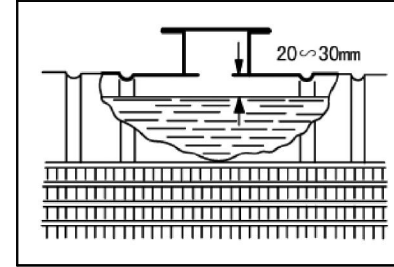

3. Check the coolant level.

Check the radiator and the coolant level in the auxiliary water tank. Add some more coolant if the level is below the lower limit. Coolant shall not be added above the upper limit.

Check the sealing of the injection port cover.

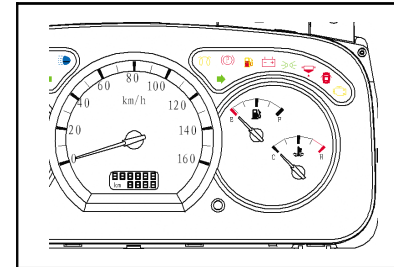

After the engine is started

1. With the engine running, check if the alternator indicator light and the oil pressure indicator light are off.

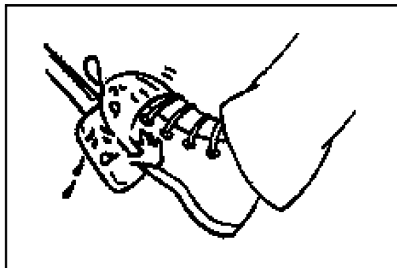

2. Check if the brake pedal back play and height are OK for normal work.

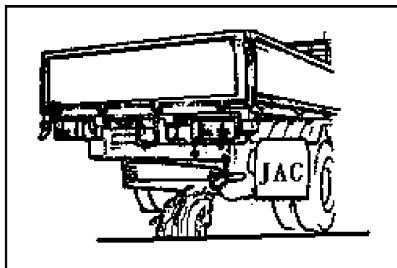

3. Check the engine for any strange noises and emission colors.

## Driving

Proper driving and maintenance will prolong the vehicle's service life, but also improve the economy of fuels and oils.

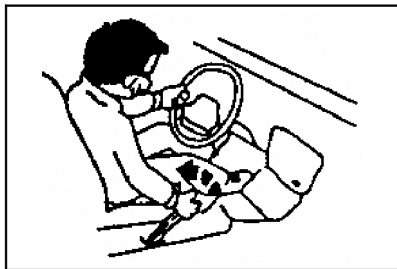

#### Preparations before startup

1. Push the parking brake handle down to the end.

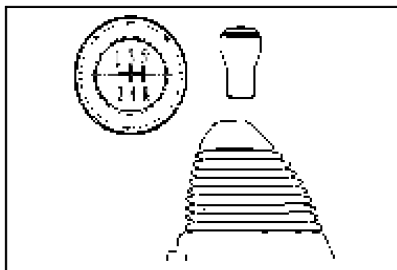

2. Put the gearshift lever in the neutral position.

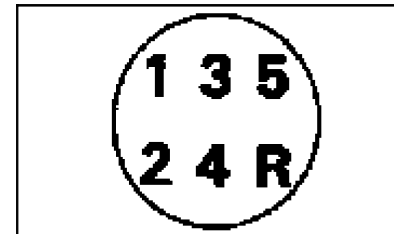

3. The gear shift chart on the lever handle.

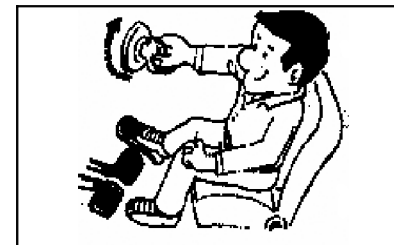

#### Engine startup

Turn the start switch to "ON" position, check if the horn and the instruments in the panel are working properly, if the turn signal lights and brake lights are OK, and if the door mirrors are correct in angles and positions.

1. Normal startup

Turn the key to START, and the engine will get started, immediately release the clutch pedal. Keep low speed running, do not step hard on the accelerator.

2. Startup in winter

If one startup fails in the normal way, start the engine for the second time after two minutes. When it is very cold and the above method does not work, the following steps can be taken for startup:

- a. Use hot water as the cooling water. Open the drain cock when adding hot water, and do not close it until hot water flows out.
- b. Heat up the engine oil to about 80°C-90°C before adding it to the oil sump.

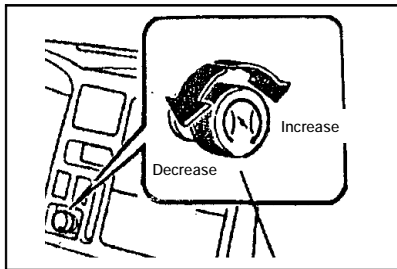

3. When the engine fully warms up, the idling control knob should be turned back to its original position.
4. Do not accelerate as soon as the engine is started, it is better to idle run for 3-5 minutes before driving, to achieve good lubrication. Take care that idling time shall not be too long.

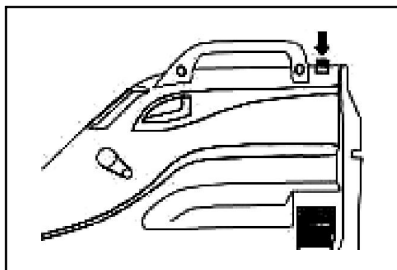

- Before vehicle running
1. Lock all the doors.

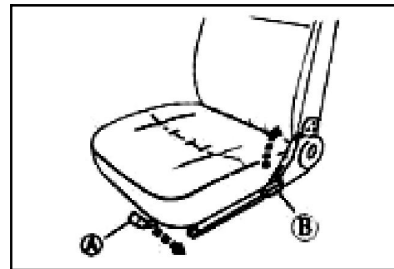

2. Adjust the seat.

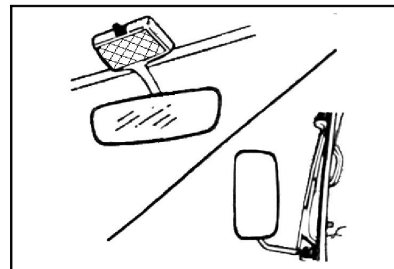

3. Adjust the rear-view mirror and the door mirrors.



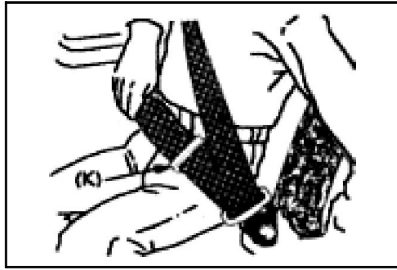

4. Tighten the seat belt.

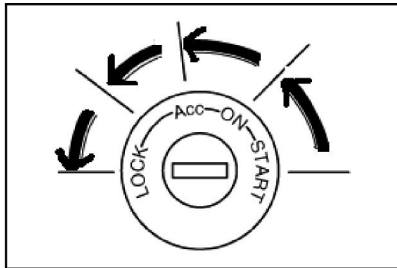

#### Engine stopping

Turn the start switch to "ACC" (accessories) or "LOCK"(lock firm) position.

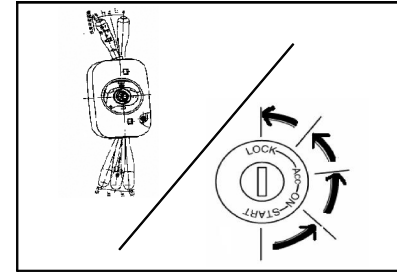

#### Parking

1. Check if the light control switch and the turn signal light switch are in off positions. The headlights, turn signal lights and small lights can still be operated even if their start switches are in off positions.
2. To have the parking brake work reliably. If the vehicle is to be parked on a slope unattended, some wheel wedges must be put under the wheels.

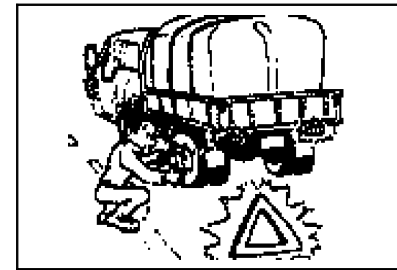

If the vehicle must be parked on the road for some reason, it should be parked near the road curb instead of on the roadbed. If the vehicle breaks down in the middle of a road in a special case, a warning sign should be placed 200M in front of and behind the vehicle respectively.

Try to avoid stopping on slopes. If necessary to stop on a slope, the parking brake handle should be pulled up completely, and shift into low speed. Put triangle pads or stones behind the wheels to prevent back sliding. Parking on a slope should have the parking brake work reliably, with the emergency lights on.

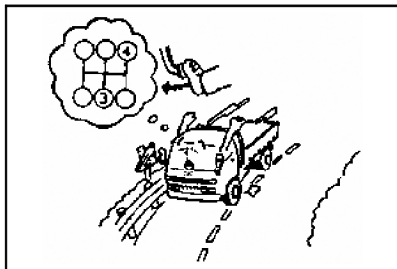

#### Attention points for driving

##### 1. Avoid over speed running of the engine

When going down a slope, pay special attention to avoiding over speed running of the engine. Engines are prone to run at over speed when shifted to low speeds.



2. If abnormal noise is heard or strange smell is smelt during driving, stop driving at once and find out the reason for that.

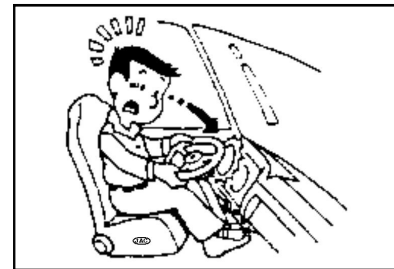

3. If the indicator lights or instruments are not working correctly during running, stop driving at once and find out the reason for that.

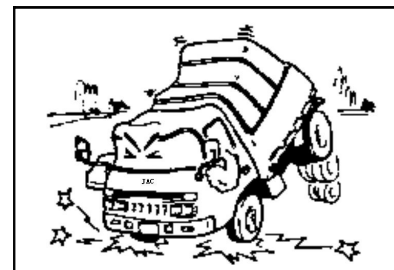

4. Try to avoid abrupt acceleration and emergency brake as much as possible.

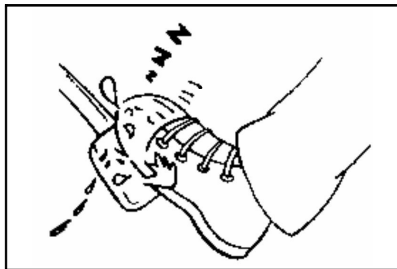

5. Do not leave the foot on the clutch pedal during driving, or partial separation will occur and this will bring about premature wear of the clutch discs.

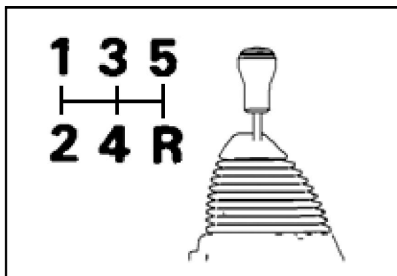

6. Before and after backing, the vehicle must be stopped still before shifting the lever to the Reverse gear or shifting back to Gear 1 position.

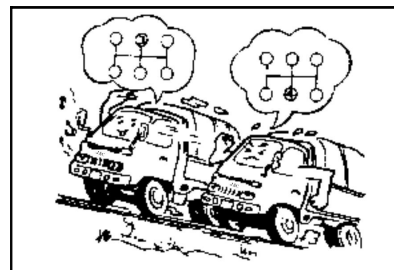

7. When going up a slope, to avoid engine overload, the gearshift lever should be moved to the low speed in time before the engine begins to load up and slow down.



8. When going down a slope, the gearshift lever should be moved to low speed so as to have the braking effect from the engine deceleration.

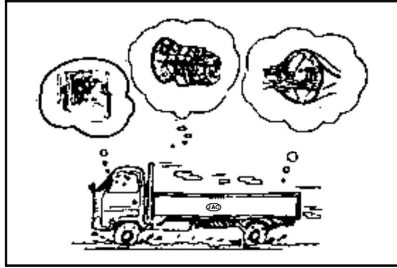

9. Carefully drive across shallow rivers or puddles of water, so as not to have water get into the air pipe and bring about serious damage to the engine, After passing streams or water, check whether any water has got into the rear axle and the gear oil in the gear box. If water is found in it, drain the gear oil and then refill to the specified quantity.



10. Pay special attention during driving heavy rains or shallow streams, because the brake will be wet and exert less braking force.

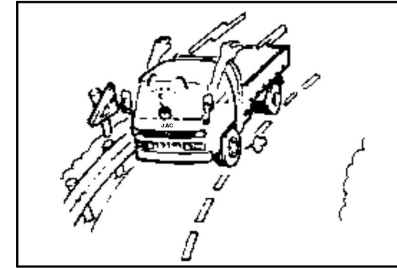

11. Never stop the engine during driving; otherwise the braking effect will go down due to the braking booster stopping. If the pneumatic switch is turned to "LOCK" position during driving, it will cause great danger, because the steering wheel is locked and the vehicle is beyond control.

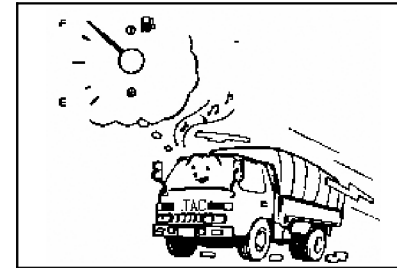

#### Economic driving

1. Unnecessary high-speed running, or slow running with the gearshift lever in high speed, will cause over-consumption of fuels.

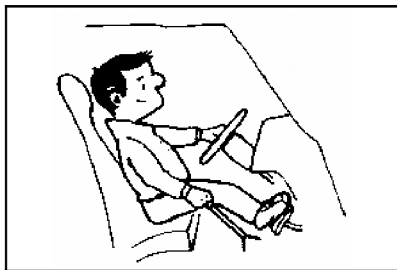

2. After acceleration, the gearshift lever should be put in high speed, slowly releasing the clutch pedal.



3. Move the gearshift lever into direct gears or overpass gear, to keep certain speed as much as possible.

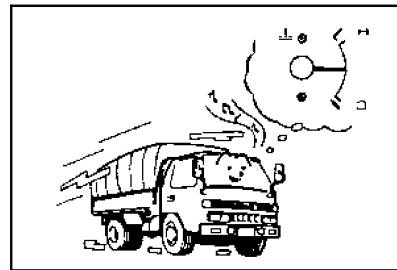

4. The cooling water temperature should be kept in the normal range during driving.

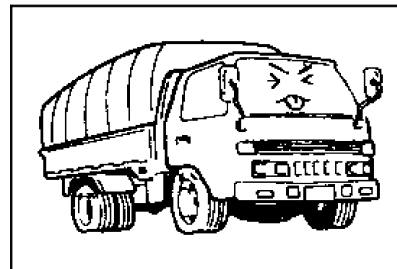

5. If the tires are not pumped enough, there will be more fuel consumption.

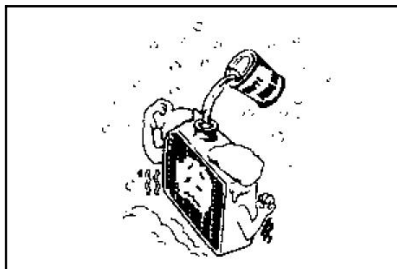

### Vehicle management and maintenance in winter

#### Use of anti-freeze fluid

The freezing temperature of the cooling water for engine will vary with the content of the anti-freezing fluid in it.

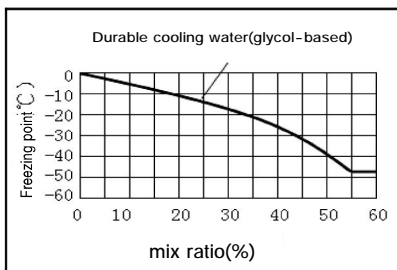

1. The correct mixing ratio of the anti-freezing fluid can be set according to the curve shown in the figure on the left.  
It is users' responsibility to keep right content of anti-freezing fluid corresponding to the ambient temperature where the vehicle is used.

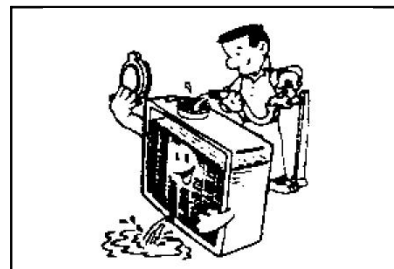

2. It is better to wash the inside of the cooling system before glycol based cooling water is used.
3. Any damaged rubber hose should be replaced, because the engine cooling water will leak out even if the cracks are very small in the hose.

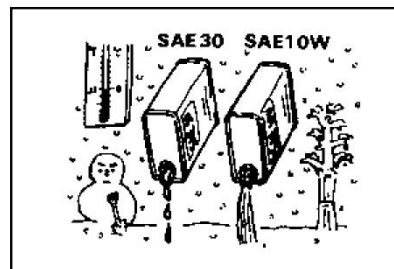

#### Engine oil

With the ambient temperature going down, the engine oil viscosity will go up. Use the engine oil with viscosity suitable to the ambient temperature.

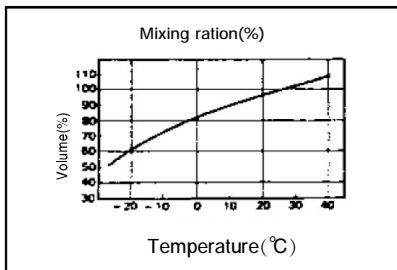

#### Battery

The battery capacity will decrease along with the drop of ambient temperature. The specific gravity of electrolyte will also go down with the rise of discharging rate.

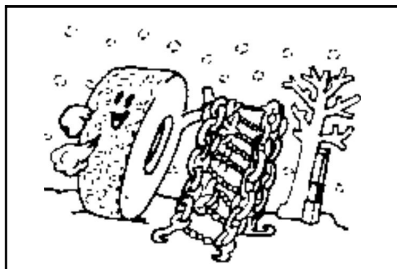

#### Running on ice or snow

1. It is suggested that anti-skid chains or snow-road tires be used.



2. Avoid high speed driving, abrupt acceleration, emergency brake or sudden turning.



3. Use low speeds so as to get the braking effect from the engine deceleration, and be careful in using foot brake system.

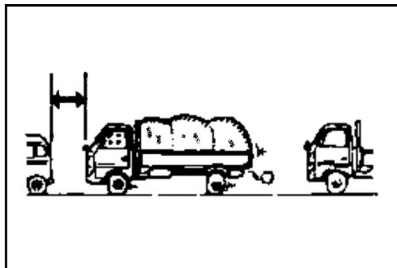

4. Keep enough distance with vehicle ahead during driving.

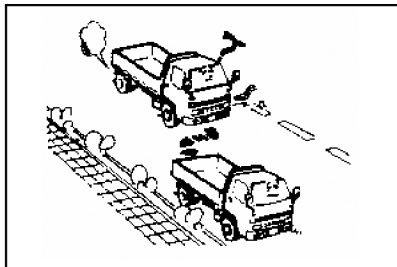

In emergency cases

Emergency stop

1. If it is necessary to park on a road for some reason, try to stop the vehicle as close to the road side as possible, never stop in the roadbed.

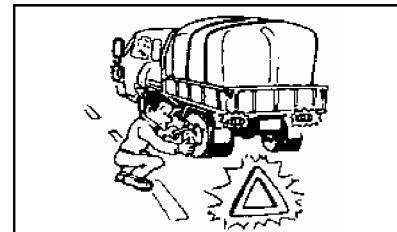

2. Put the parking brake into reliable braking state, meanwhile, the danger warning flash light should be used no matter if it is daytime or evening.

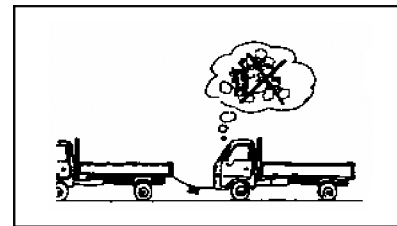

Emergency start

It is forbidden to start the engine by way of traction from another truck, because the engine starting may have forward impact, which will cause possible collision with the truck that gives traction.

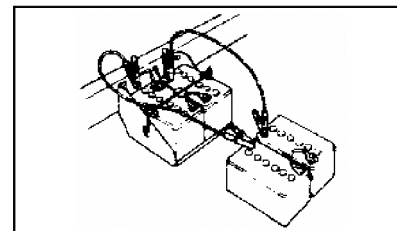

When the battery is already totally discharged out, the 12V auxiliary battery, with a same rated voltage as the battery, can be used if you want to start the vehicle.

Be very careful in handling with the battery, to avoid serious injury, explosion, sparks from acid liquid firing and the consequential damages to the vehicle or electric elements.



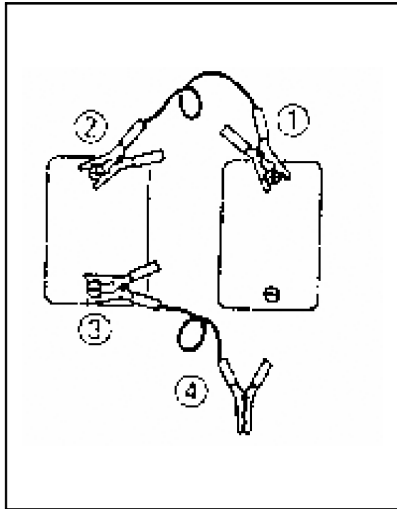

#### Wiring connection steps

Jumper cables can be used to connect the battery in another truck to start the engine in the truck that has trouble.

1. Use a truck that is provided with a battery of the same rated voltage (12V).
2. Connect the jumper cable in the following steps.
  - ① positive terminal of the totally discharged battery
  - ② positive terminal of the auxiliary battery
  - ③ negative terminal of the auxiliary battery
  - ④ The chassis grounding wire with the totally discharged battery, the grounding wire be away from the totally discharged battery as far as possible.
3. After the jumper cable is connected, start the engine in the truck that has auxiliary battery.
4. Increase the speed of the engine in the truck that has auxiliary battery, and then start the engine in the truck whose battery is totally discharged.
5. After the engine gets started, disconnect the jumper cable in the reverse order.

Never connect the cable between the positive and negative terminals. Do not disconnect the cable from the terminal pillar while the engine is still running, otherwise a failure will occur in the electrical system.

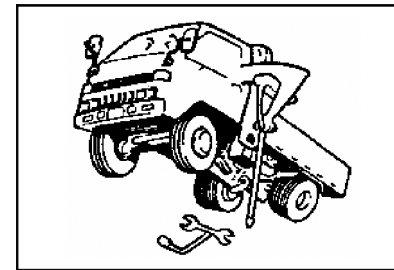
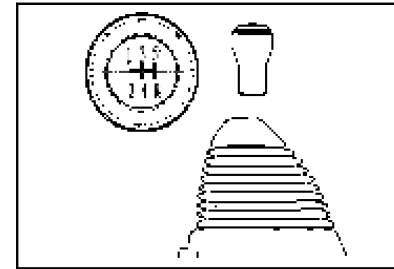

#### Traction

Pay attention to the following points when tracking vehicles:

1. If the gearbox can work normally, its gearshift lever should be placed in neutral.
2. If any failure occurs to the transmission, it will be necessary to dismantle the propeller shaft from the flange on the rear axle and have its end tightened to the frame. Then, put the traction cable (safety chain or cable) onto the hooks of the tracking truck and the vehicle that cannot run. Traction shall be done at a speed of 40km/h or below.

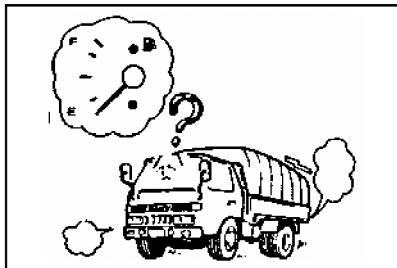

#### Venting of the fuel oil system

If the fuel in the tank is used up, it is likely that air has been sucked into the fuel oil system. If it is the case, fuel oil will not be able to get sucked into the engine. To prevent such phenomenon, venting must be done for the fuel oil system.

For venting of the HFC4DA1 series diesel engine, loosen the nut of high pressure pipe of Cylinder 4, use the starter to start the engine for about 10 seconds before tighten the nut.

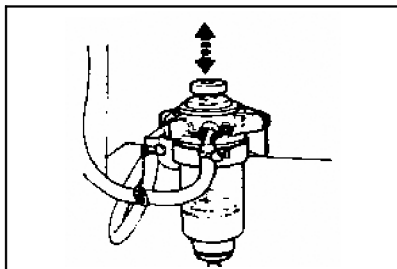

1. Press up and down the handle of the manual oil pump fixed on the oil/water separator for several times, to lead the fuel containing air from the fuel oil system into the jet pump.
2. After the venting of the fuel oil system is finished, start the engine with the start switch.
3. If the engine fails to start within 10 seconds, then repeat Step 1 and 2.

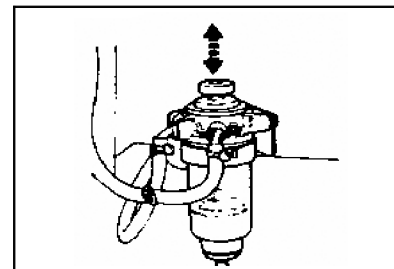
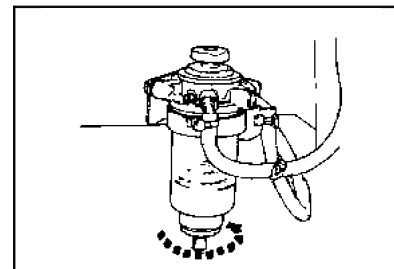

#### Oil/water separator and drainage

When the indicator light of the oil/water separator is on, drainage of water must be done as per the steps below.

1. Find a safe place to park the truck.
2. Open the engine hood, loosen the drainage plug counterclockwise, and push up and down the handle of the manual pump on the oil/water separator for several times, until about 0.1L water is drained.
3. After drainage, tighten the drainage plug clockwise, and push up and down the handle of the manual pump on the oil/water separator for several times.
4. After the engine is started, check if any fuel is leaking from the drainage plug. Meanwhile, check if the indicator light of the fuel filter is off or not.

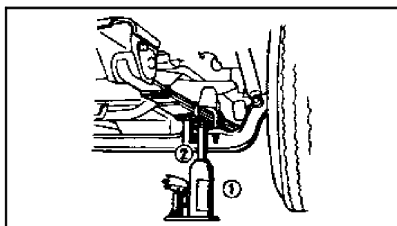
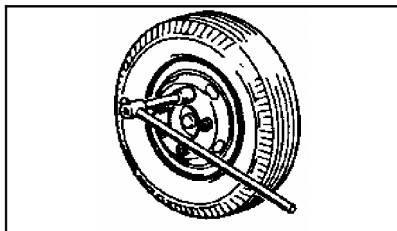
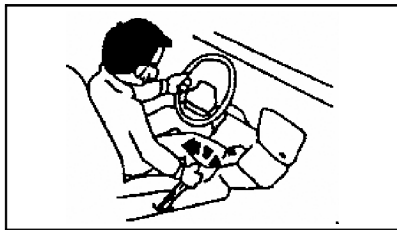

Jack up the truck for replacement of leaking tires

Preparations

1. Park the truck on a flat ground; pull tight the parking brake handle.
2. Pull the gearshift lever into the reverse position.
3. Turn on the danger warning flash light.
4. Put stoppers behind the wheels diagonal to the jack-up position.
5. Loosen the wheel nuts but do not take them off. The nuts in the right wheels have right threads, and the nuts in the left wheels have left threads.
6. Place the jacks under the following support points specified.

Front wheels:

- ① The first spring piece from the bottom of the leaf spring.
- ② The second spring piece from the bottom of the leaf spring.

Rear wheels:

- ① Only applicable for vehicle with low flat floors.

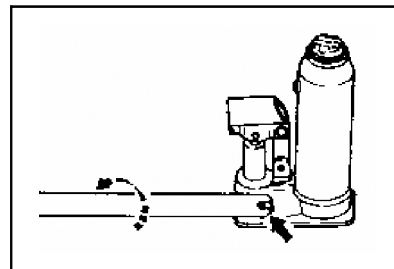
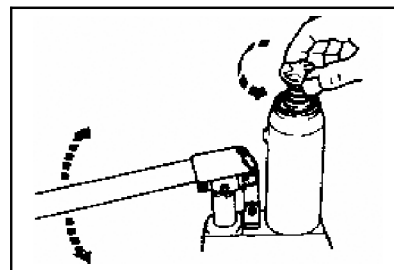

Information about jacks

Jack up:

If the jacking point of the vehicle is higher than the top of the jack, turn the jack head counterclockwise to protrude longer.

As shown in the figure, insert the jack handle and pull it up and down.

Lay down:

With the jack in the state as shown in the figure, slowly loosen the vent hole screw counterclockwise.

Never jack up the truck on a slope or soft ground, otherwise it cause serious danger.

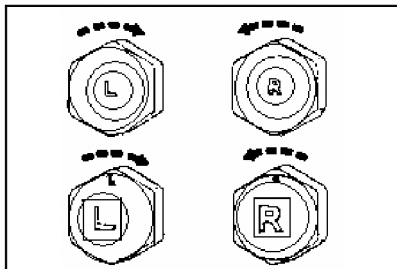

Wheel replacement:

1. Loosen the wheel nuts with a wheel nut spanner.

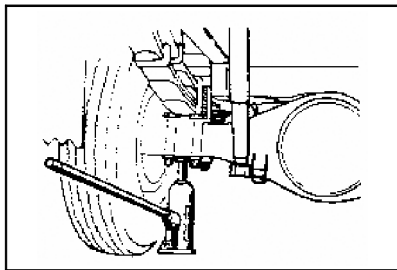

2. Jack up the wheel, screw off the wheel nuts, take down the wheel, and then install the spare wheel.

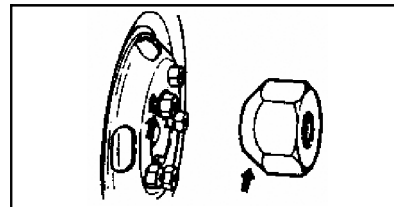

3. Place and tighten the wheel nuts for the moment, and lower down the wheel onto the ground.

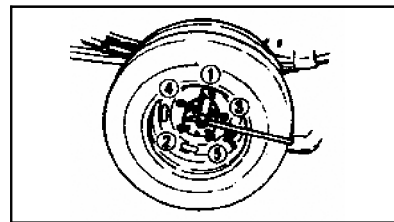

4. Tighten the wheel nuts with a wheel nut spanner in the order as shown in the figure below. Now securely tighten the nuts with the tightening torques below.

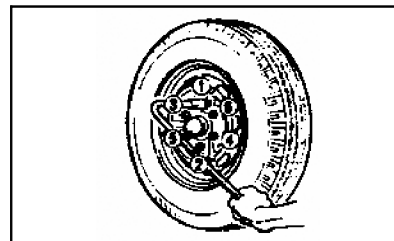

Tightening torques for wheel nuts (Nm)

Front wheels: 137~196

Rear wheels: 343~441

## Repair and maintenance

To ensure safety and economic driving, regular routine repair and maintenance should be made according to the items specified in this chapter.

Schedule of regular routine maintenance

To ensure driving safety and the best economic driving, regular check and maintenance should be entrusted to specified JAC service stations according to the schedule of regular maintenance.

Maintenance job number

I: check and repair or replace as needed

A: adjustment

R: replacement or adjustment

T: tighten as per the specified torques

L: lubrication

The daily checking items shall be checked together with the checking of the following items.

The symbol “\*” means the following:

More frequent maintenance shall be done under harsh driving conditions. Please refer to the "Schedule of regular maintenance under adverse driving conditions".

Schedule of engine maintenance under general conditions

Technical maintenance periods 1000km (per reading in odometer)	3	6	9	12	15	18	21	24	27	30	33	36	39	42	45	48	51	54	57
Engine oil	R	R	R	R	R	R	R	R	R	R	R	R	R	R	R	R	R	R	R

Schedule of regular maintenance under adverse driving conditions

Technical maintenance periods 1000km (per reading in odometer)	3	6	9	12	15	18	21	24	27	30	33	36	39	42	45	48	51	54	57
Engine oil	R	R	R	R	R	R	R	R	R	R	R	R	R	R	R	R	R	R	R

R: Change or replace

### Schedule of regular maintenance

Period: ×1000km (calculated per the readings from the odometer or months, and do the maintenance at the time whichever comes first) or months	1	3	6	9	12	15	18	21	24	27	30	33	36
	-	1	2	3	4	5	6	7	8	9	10	11	12
Model HFC4DA1 series engine													
Engine oil													
Engine oil filter element	R	-	-	-	R	-	-	-	R	-	-	-	R
Air filter element	-	-	-	I	-	-	I	-	-	I	-	-	R
Fuel filter	-	-	I	-	I	-	R	-	I	-	I	-	R
Idling and acceleration functions	-	I	I	I	I	I	I	I	I	I	I	I	I
Engine oil leakage and contamination	-	I	I	I	I	I	I	I	I	I	I	I	I
Fuel leakage	I	I	I	I	I	I	I	I	I	I	I	I	I
Valve gap	A	-	-	-	-	-	-	-	-	-	-	-	A
fuel pump function	-	-	-	-	-	-	-	-	-	-	-	-	I
Fuel tank	-	-	-	-	-	-	-	-	-	-	-	-	I
Oil/water separator	-	I	I	I	I	I	I	I	I	I	I	I	I
Spraying state under oil spray pressure	-	-	-	-	-	-	-	-	-	-	-	-	I
Oil injection timing	-	-	-	I	-	-	I	-	-	I	-	-	I
Contraction pressure	-	-	-	-	-	-	-	-	-	-	-	-	I
Cooling system leakage	-	I	I	I	I	I	I	I	I	I	I	I	I
Tension and damage of the drive belt	I	I	I	I	I	I	I	I	I	I	I	I	I
Engine control mechanism	-	L	L	L	L	L	L	L	L	L	L	L	L
Damage and slack of exhaust pipe and its fittings	-	-	-	I	-	-	I	-	-	I	-	-	I
Clutch													
Clutch fluid and brake fluid	-	-	-	-	-	-	-	-	-	-	-	-	R
Clutch function	-	I	I	I	I	I	I	I	I	I	I	I	I
Travel and free travel of clutch pedal	-	I	I	I	I	I	I	I	I	I	I	I	I
Transmission													
Transmission oil	R	-	-	-	-	-	-	-	R	-	-	-	-
Oil leakage	I	I	I	I	I	I	I	I	I	I	I	I	I
Slack of gear control mechanism	-	-	-	-	-	-	-	-	-	-	-	-	I
Gear control mechanism	-	L	L	L	L	L	L	L	L	L	L	L	L

### Schedule of regular maintenance

Period: ×1000 km (calculated per readings from the odometer or months, and do the maintenance at the time whichever comes first) or the months	1	3	6	9	12	15	18	21	24	27	30	33	36
	-	1	2	3	4	5	6	7	8	9	10	11	12
Propeller shaft:													
Universal joint and slip cap	-	-	-	-	-	-	L	-	-	-	-	-	L
Slack connecting parts	-	-	-	I	-	-	I	-	-	I	-	-	I
Over-abrasion of the spline	-	-	-	-	-	-	-	-	-	-	-	-	I
Rear axle:													
Differential oil	R	-	-	-	-	-	-	-	R	-	-	-	-
Oil leakage	I	I	I	I	I	I	I	I	I	I	I	I	I
Deformation and damage of the semi-axle at the rear axle	-	-	-	-	-	-	-	-	-	-	-	-	I
Deformation and damage of the rear axle housing	-	-	-	-	-	-	-	-	-	-	-	-	I
Front axle:													
Deformation and damage of the front axle	-	-	-	-	-	-	-	-	-	-	-	-	I
Steering system:													
Steering gear oil	-	-	-	-	-	-	-	I	-	-	-	-	I
Leakage of the steering system	-	I	I	I	I	I	I	I	I	I	I	I	I
Slack and damage of the steering system	-	-	-	I	-	-	I	-	-	I	-	-	I
Slack of universal joint and front axle accessories	-	-	-	I	-	-	I	-	-	I	-	-	I
Steering wheel windage	-	I	I	I	I	I	I	I	I	I	I	I	I
Steering wheel function	-	I	I	I	I	I	I	I	I	I	I	I	I
Steering mechanism rods	-	L	L	L	L	L	L	L	L	L	L	L	L
Over gap of the bearings	-	-	-	-	-	-	-	-	-	-	-	-	I
Slack and damage of steering mechanism	-	-	-	-	-	-	-	-	-	-	-	-	I
Left and right turning radius	-	-	-	-	-	-	-	-	-	-	-	-	I
Front wheel adjustment	-	-	-	-	-	-	-	-	-	-	-	-	I
Braking system:													
Braking fluid and clutch fluid	-	-	-	-	-	-	-	-	-	-	-	-	R
Leakage from braking system	-	I	I	I	I	I	I	I	I	I	I	I	I
Service brake function	-	I	I	I	I	I	I	I	I	I	I	I	I
Friction lining gap	-	I	I	I	I	I	I	I	I	I	I	I	I
Abrasion of friction lining and brake drum	-	-	-	I	-	-	I	-	-	I	-	-	I
Brake pedal travel and free travel	I	I	I	I	I	I	I	I	I	I	I	I	I

### Schedule of regular maintenance

Period: ×1000 km (calculated per readings from the odometer or months, and do the maintenance at the time whichever comes first) or the months	1	3	6	9	12	15	18	21	24	27	30	33	36
	-	1	2	3	4	5	6	7	8	9	10	11	12
<b>Parking brake:</b>													
Parking brake wire cable	-												
Parking brake function	-												
Handle travel of parking brake	-												
Friction lining abrasion and damage	-	-	-	-	-	-	-	-	-	-	-	-	
Brake drum abrasion and damage	-	-	-	-	-	-	-	-	-	-	-	-	
Ratchet wheel abrasion and damage	-	-	-	-	-	-	-	-	-	-	-	-	
<b>Suspension:</b>													
Leaf spring damages	-												
Slack and damage of the fixing parts	-												
Shock absorber leakage	-	-	-		-	-		-	-		-	-	
Unbalance of leaf spring due to weakened elasticity	-	-	-	-	-	-	-	-	-	-	-	-	
<b>Wheels:</b>													
King pin	T	T	T	T	T	T	T	T	T	T	T	T	T
Wheel hub damage	-												
Hub bearing lubrication	-	-	-	-	-	-	R	-	-	-	-	-	R
Tire pumping pressure and damage	-												
Tire transposition	-	-	-	R	-	-	R	-	-	R	-	-	R
Slack of the front hub bearing	-	-	-		-	-		-	-		-	-	
Slack of the rear hub bearing	-	-	-	-	-	-		-	-	-	-	-	
<b>Electrical system equipment:</b>													
Starter function	-	-	-	-	-	-	-	-	-	-	-	-	
Battery electrolyte specific gravity	-	-	-		-	-		-	-		-	-	
Slack and damage of wire harness and terminal studs	-												

### Adverse driving conditions:

- ① Frequent shuttle in short distances;
- ② Running on rough and rugged roads;
- ③ Running in dusty roads;
- ④ Running in severe cold weather;
- ⑤ Running in roads with salty atmosphere;

### Maintenance under adverse driving conditions

Items	Period	Condition					
		1	2	3	4	5	1+4
Engine oil	Replace every 1500km			1			1
Engine oil filter element	Replace every 1600km			1			1
Exhaust pipe and its fixing parts	Replace every 4500km	1	1		1	1	
Air filter element	Replace every 1800km			1			
Slack and damage of the steering system	Replace every 4500km		1				
Abrasion of universal joint and propeller shaft spline	Replace every 9000km		1				
Transmission oil and differential oil	Replace every 9000km		1				
Brake friction lining and brake drum	Replace every 4500km	1	1	1			



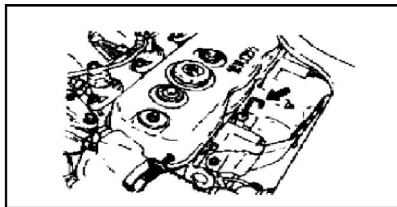

#### Guide to maintenance

##### Daily check:

##### Engine oil level

Pull out the oil leveler, wipe it clean and put it back again.

Pull out the oil leveler again to check if the oil level is between the upper and lower limits. Also check the oil contamination degree from the oil leveler.

Before checking the oil level, the truck should be parked on flat ground, and should wait 5 minutes after the engine cuts out.

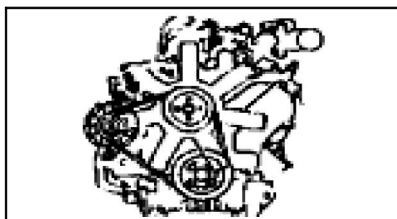
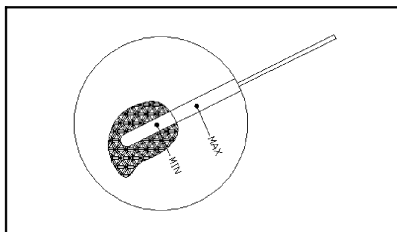

##### Fan belt

Finger press the middle part of the belt with 98Nm force, to check if the fan belt deflection is in the range of 8-12mm.

Meanwhile, check the belt for any cracks or damages.

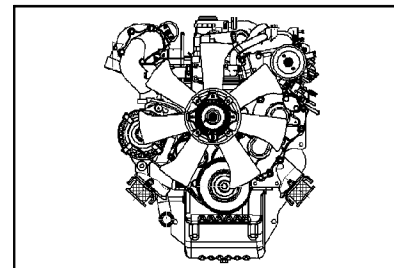

If the belt tension is too small, the battery may be undercharged or the alternator gets overheated. But the over-tension will bring about damages to the AC engine or V belt.

The fan belt should be carefully checked. If it is broken, the vacuum booster and the exhaust auxiliary brake will not able to function.

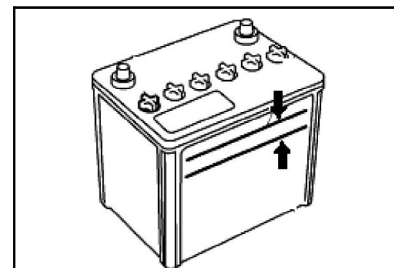

##### Battery electrolyte level

The battery electrolyte level should be between the upper and lower limits. If the level is too low, distilled water should be added in time.

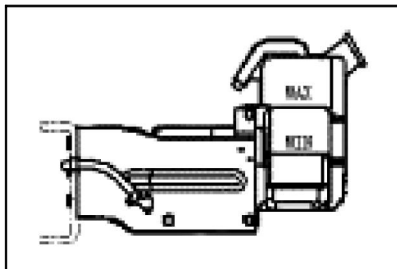

#### Cooling water level

Check the cooling water quantity, and add cooling water to the standby water tank for the radiator, if needed. If the water level in the standby water tank is below "MIN" scale, check the radiator or rest of the cooling system for any leakage, before adding cooling water up to "MAX" scale.

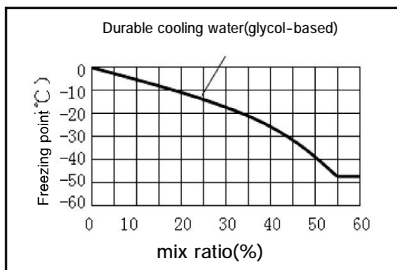

1. When adding cooling water, its level shall not go above the "MAX" scale in the standby water tank.
2. Do not take off the radiator injection port cap if not necessary.
3. Check the cooling water level only after the engine cools down.
4. When running in very cold areas, please add anti-freeze fluid of the mixing ratio corresponding to the ambient temperature, in order to prevent the cooling water from freezing.

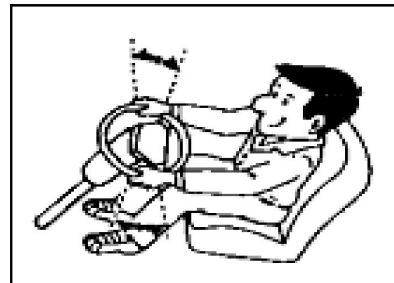

#### Steering wheel

To check the backlash play of the steering wheel, turn the steering wheel right and left till the tires begin to turn.

The backlash should be in the following range.

Manual steering mechanism: 10-30mm

Power steering mechanism: 10-50mm

At this moment, measure the backlash play along the periphery of the steering wheel with the front wheels heading exactly forward.



If the truck is provided with power steering mechanism, measure the steering wheel backlash with the engine running.

Besides, sway the steering wheel right and left or back and forth to see if it is slack.

During driving, check if the steering wheel is difficult to steer, if it is vibrating or pulled back to one side, etc.

If some abnormal phenomena are found, such as big gap and slack of the steering mechanism parts, immediately entrust the specified JAC automobile service stations to check the steering mechanism.

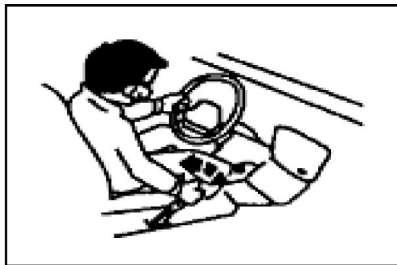

**Handle travel of the parking brake** The normal travel of the parking brake handle is: 5-8 notches.

This is the value for pulling back the handle with a force of 20kg.

If the travel of the parking brake handle is more than 16 notches, it means braking is insufficient. The parking brake should be adjusted.

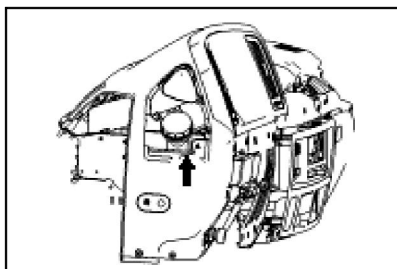

**Brake fluid level and clutch fluid level**

Check if the level in the fluid reservoir is up to the specified level mark. If the level in the reservoir is lower than ADD scale, add some more brake fluid recommended.

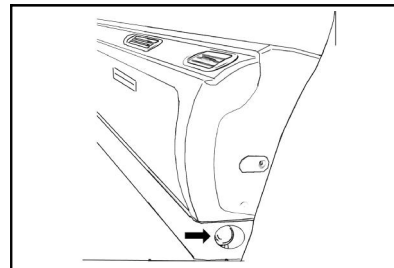

**Windshield cleaning fluid level**

Check if the cleaning fluid level is OK in the pot. And also check if the windshield washer functions properly.

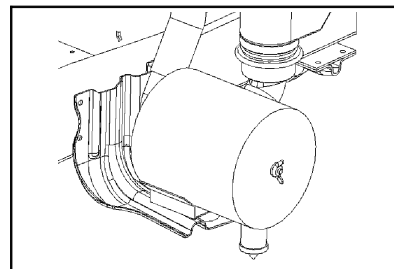

**Routine maintenance**

**Air filter**

The blocked air filter element will decrease the engine output capacity, but also increase the fuel consumption and black emissions. So, the air filter should be under maintenance in the following ways.

Please use the original JAC filter elements when replacing them.

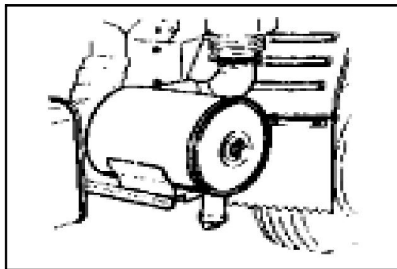

Filter element removal (behind the cabin)

1. Tighten the butterfly nut and remove the cover.
  2. Screw off the butterfly nut that fixes the element before taking it out.
- Handle the element with care against any damage.

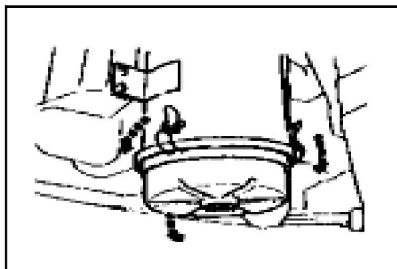

Filter element removal(behind the cabin)

1. Screw down the butterfly nut and take off the cover.

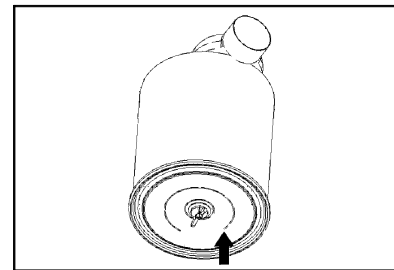

2. Screw off the butterfly nut that fixes the element before taking it out.
- Handle the element with care against any damage.

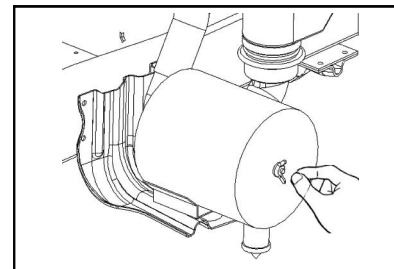

Cleaning of the air filter housing and cover Wipe off the dust from the inside of the air filter housing, the cover and the sealing gasket.

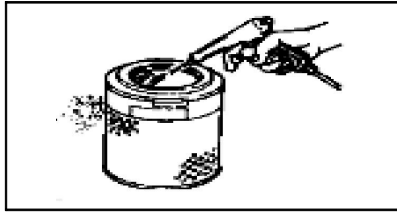

### 3. Filter element treatment

Cleaning of the filter element is done in one of the following methods dependent on its contamination.

The filter element is dust contaminated but still dry:

Turning the element with hand, and blow off the dust from its inside with compressed air, whose pressure should be below 7kg/cm<sup>2</sup>.

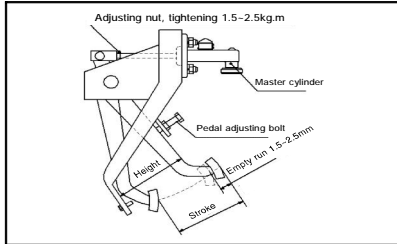

### Clutch pedal adjustment

1. Loosen the blocking bolt or the clutch switch, and adjust the clutch pedal height to the specified value. 2. Loosen the locknut and adjusting nut of the follow-up cylinder. Screw down the adjusting nut until it contacts the clutch shift fork, and then screw it back for one and a half round.

3. Tighten the locknut.

4. Adjust the pushrod length of the master cylinder, to bring the backlash of the clutch pedal up to the specified value (this needn't be done in trucks provided with servo mechanism).

5. Adjust the clutch switch gap (L), to keep it within 0.5-1.0mm.

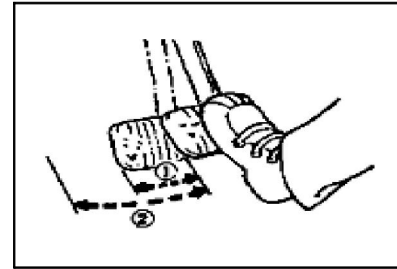
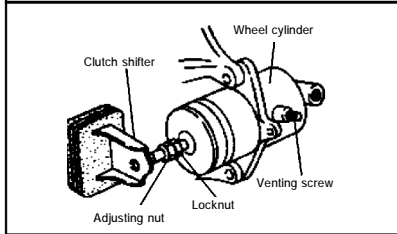

### Clutch pedal backlash and standard height

(1) Backlash: 15-25mm

(2) Height: 205-213mm

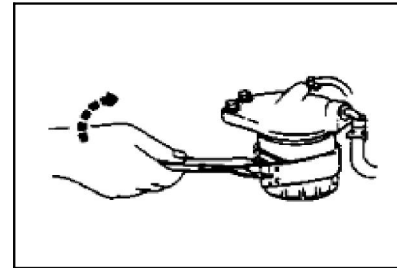

### Fuel filter

1. Loosen the filter counterclockwise with a filter spanner.

2. Clean the mating surface of the filter bonnet with a piece of cloth, in order to have the filter installed firmly on the mating surface.

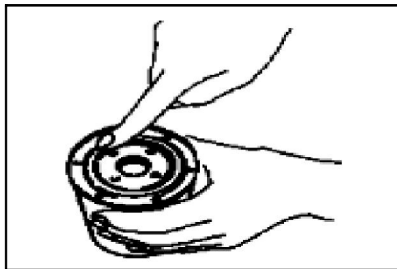

3. Apply a thin layer of engine oil to the O ring surface. Place the O ring in, and take care not to have the fuel overflow while tighten it slowly inside the filter, until it sits firmly against the sealing surface.

Afterwards, further tighten the filter by 2/3 round with a filter spanner.

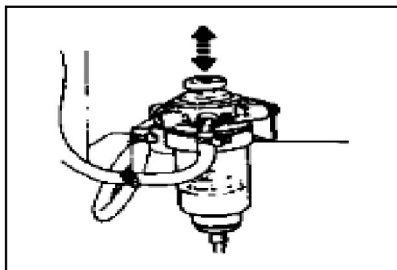

4. Operate the handle of the manual pump on the oil/water separator for several times to vent the fuel system.

5. After the fuel filter is vented, start the engine with the start switch.

6. If the engine fails to start within 10 seconds, vent the system again.

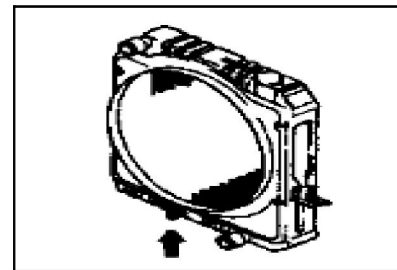

#### Engine cooling water

To change the cooling water, loosen the discharge valves on the radiator and cylinder block to drain the water out of the cooling system.

The engine cooling system should be washed at least once a year, to ensure the best cooling effect.

JAC recommends use of anti-freezing fluids without any content of rust preventive and other additives.

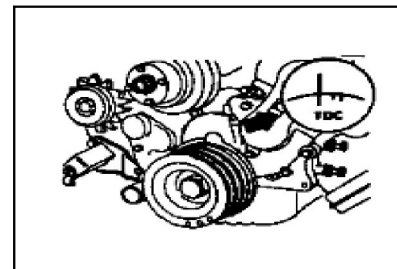

#### Valve clearance adjustment

1. Turn the crankshaft until the top dead center on the crankshaft pulley is in alignment with the timing mark, to have the piston in the first or the fourth cylinder move to the top dead center of the compression stroke.

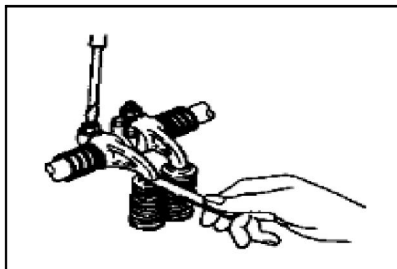

2. Adjust the valve clearance with a feeler gage:  
Valve clearance (the engine in normal temperature)  
Inlet valve: 0.4mm  
Exhaust valve: 0.4mm

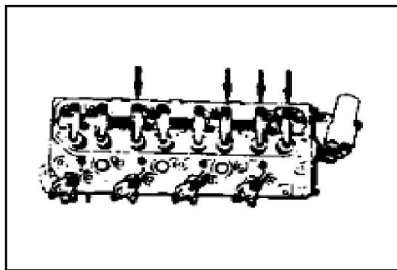

3. First, adjust the valve clearance shown by the arrow in the figure.

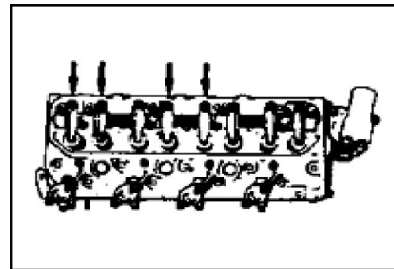

4. Turn the crankshaft one round (360 degrees), go on adjusting the valve clearance shown by the arrow in the figure.

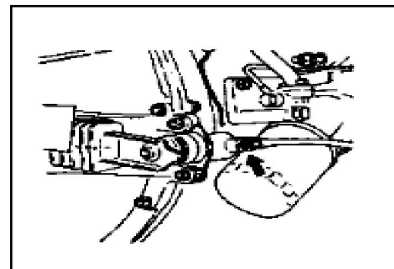

- Venting of the brake hydraulic loop  
If air gets into the brake hydraulic loop, the brake will have incomplete disengagement. So, venting must be done if the brake fluid runs out due to failure to find that the fluid quantity is not enough in the brake fluid reservoir, or if the hydraulic loop is disassembled.  
Venting shall be done by two persons together.

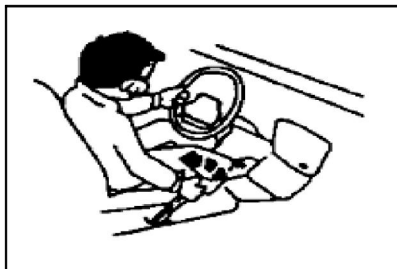

Vent the air in the following steps:

1. Pull tight the parking brake handle.

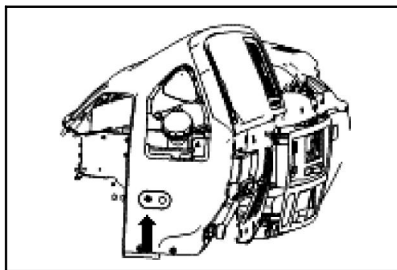

2. Check the brake fluid level in the reservoir, and add some more if needed.

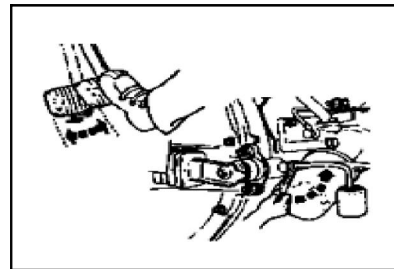

3. Take off the rubber cap from the venting screw plug, and clean the venting screw plug. Place the other end of the ethylene hose into the transparent vessel.

4. Repeatedly step on the brake pedal, and keep it stepped on.

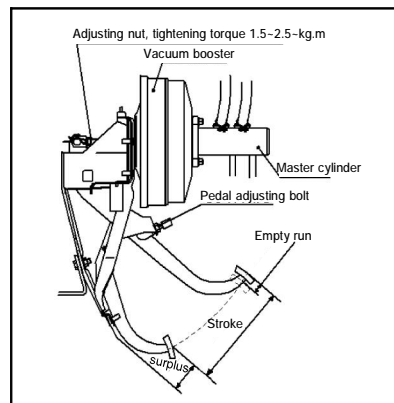

#### Brake pedal adjustment

Check the free travel and height of the brake pedal, and make adjustment in the following methods if needed.

- ① Loosen the adjusting nut of the U clamp.
- ② Turn the pedal adjusting bolt to adjust the pedal height, and then tighten the adjusting nut of the U clamp.
- ③ Adjust the free travel of the brake pedal by means of the pedal adjusting bolt.

#### Standard values

Free travel: 4-7mm;

Height: 185-193mm;

Margin: more than 65mm.



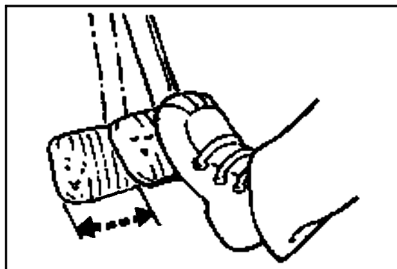

#### Main brake adjustment

It is not safe to use the brake system with too big brake shoe clearance, because the brake system performance will go down along with the brake shoe clearance increase, which should be regularly checked and adjusted according to the specified time period.

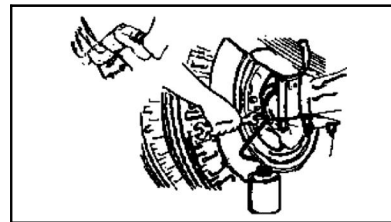
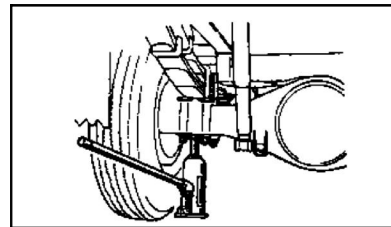

Adjust the front / rear wheel brakes in the following

1. Jack up the wheels off the ground completely;
2. Take off the rubber plug from the rear adjusting hole in the brake base plate.
3. Insert a screw driver into the adjusting hole, and turn the pinion in the direction shown by the arrow until the wheel is braked;
4. Turn the adjuster back by 5-9 notches;
5. Reposition the rubber plug;
6. Go on adjusting the brakes for the rest of the wheels in the adjustment steps above.

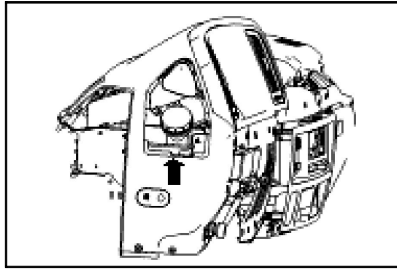

#### Venting of the brake hydraulic loop

If air gets into the brake hydraulic loop, the braking effect will go down. So, venting must be done if the fluid level is found very low in the brake fluid reservoir or the hydraulic loop is disassembled during the brake maintenance. Venting shall be done by two persons together.

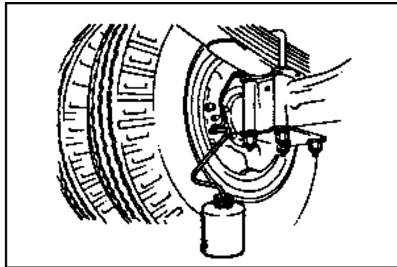

Vent the air in the following steps

1. Truly release the parking brake.
2. Start and keep the engine in running until the vacuum degree goes up adequately.

If venting is done with the engine not running, adverse impact will occur to the vacuum booster.

3. Check the level in the brake fluid reservoir, and add some more if needed.

Vent the brake hydraulic loop in the following steps.

Rear right wheel—rear left wheel—front right wheel—front left wheel.

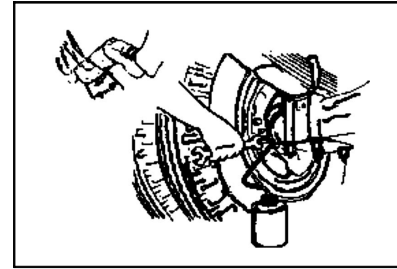

4. Take off the rubber housing from the venting screw and clean it. Connect the ethylene hose to the venting screw, and put the other end of the hose into a transparent vessel.

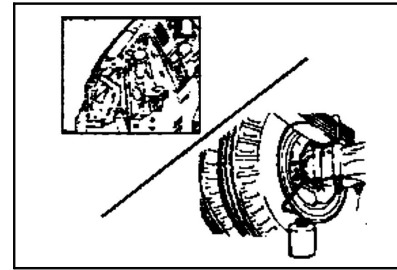

5. Repeatedly step on the brake, and keep it stepped on.
6. Loosen the venting screw, and discharge the brake fluid with bubbles together into a vessel, and tighten the venting screw at once.

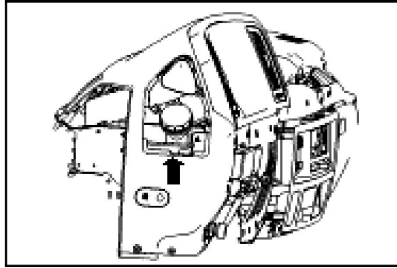

7. Slowly release the brake pedal, and do it repeatedly until bubbles disappear in the brake fluid pumped into the vessel. During the venting, keep the brake fluid in the brake fluid reservoir at the specified level. Put the housing back in position after venting is over.

8. After venting is finished for all the wheels, check the level in the brake fluid reservoir, and add some more if necessary.

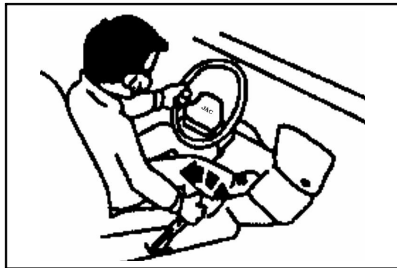

#### Parking brake adjustment

It is normal that the parking brake handle travels up to 5-8 notches if it is pulled with a force of 30kg. The parking brake can be adjusted in the following ways:

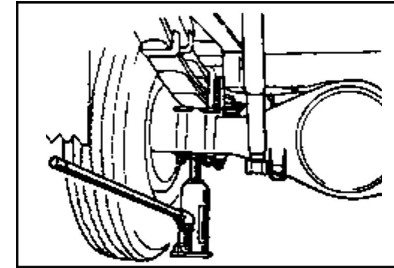

1. With the front wheels fixed, release the parking brake.
2. Jack up the rear wheels off the ground completely; pull the gearshift lever back to the neutral. Turn the propeller shaft to align the adjusting hole in the brake drum with the pinion. The adjuster is located below the center line of the propeller shaft.

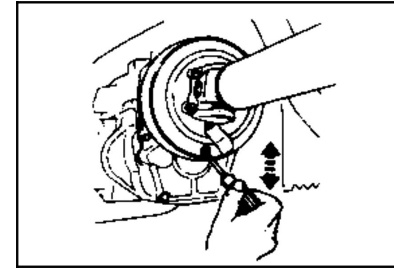

3. Insert a screw driver into the adjusting hole in the brake drum; turn the pinion upward until it can be turned no more.
4. Turn the pinion back from the above position by 25 notches, and then check the travel of the parking brake handle.

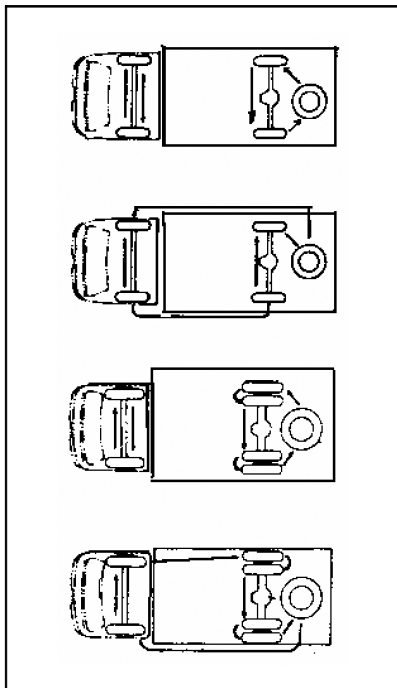

If the parking brake handle still travels more than the standard value, then use the adjusting nuts to adjust the length of the parking brake cable.

- (1) Loosen the locknut.
- (2) Use adjusting nut and adjusting bolt to adjust the length of the parking brake cable.
- (3) Tighten the adjusting nut, and lock it with locknut.

#### Tire replacement in rotation

In order to keep an even abrasion degree of all the wheel tires and to prolong their service life, the front and rear tires should be exchanged in their positions in the order shown in the figure.

Exchange the tires every 9000km.

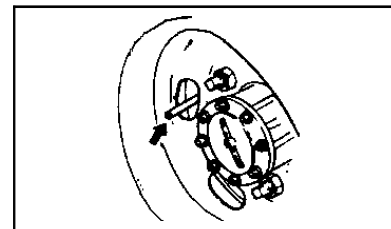
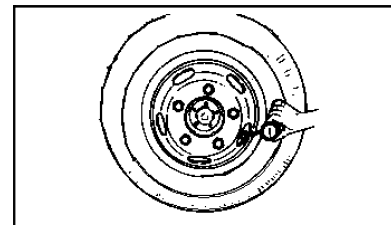

#### Inflation pressure of tires

The standard inflation pressure for the tires: 670kPa

The tire pressure check and their maintenance should be done at the time when they are in cold state (over 3 hours parking or less than 1.6km running).

It is mandatory to keep a tire inflation pressure value up to the requirement.

For the trucks with dual wheels as the two-tire rear wheels, it will suffice to use general inflating valve spanner to help measure the air pressure of the tires on the inner side.

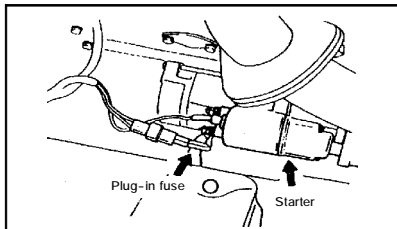

#### Insert type fuse

If the head lights or other elements cannot work but the fuse is OK, then you should check the insert type fuse. If it is already melt broken, change for a new one. A JAC insert type fuse must be used for the change.

No steel wire is allowed to be used, even if it is temporary use. It will bring about great damage or even fire.

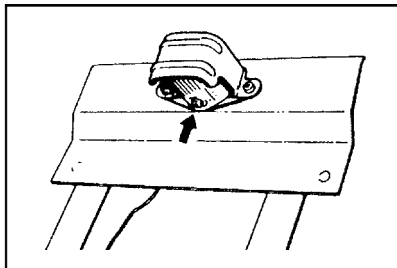

#### License light

Screw off the fixing bolts before taking down the glass.

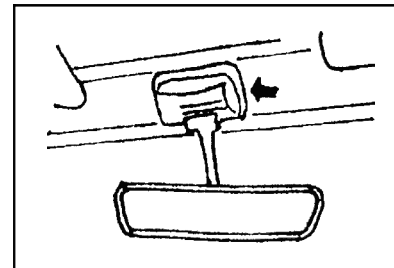

#### Roof light and interior mirror

The lampshade can be simply taken out by hand, and then take down the bulb.

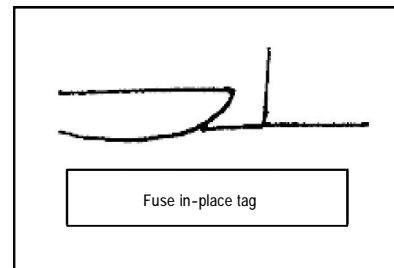

#### Fuse box

The fuse box is located under glove compartment. Open the fuse box and you can check and replace the fuse. The box cover can be pulled out by hand.

Please use a pair of nipper pliers to change the fuse.

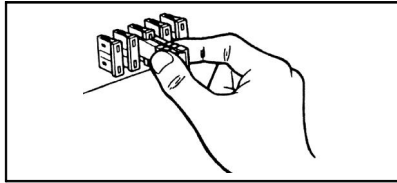

If the fuse is found broken, check and try to find out the reason for that. Take necessary maintenance measures before fuse replacement.  
Before changing the fuse, turn the start switch to "LOCK" position, and must use fuses of the same current rating.

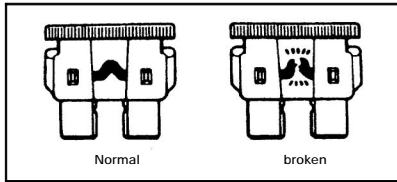

schematic of different fuse installation																				
15A	10A	15A	15A	15A	15A	20A	15A	15A	30A		15A	20A	30A	20A	15A	20A	15A	15A	10A	30A
venting brake	instruments	air conditioner	flasher	wiper cleaning	acoustic apparatus	motor-driven glass	cigarette lighter	cut out	startup	disconnecter	fuse clip	spare fuse		small lights	low beam	high beam	horn	brake reverse	roof light	air conditioner

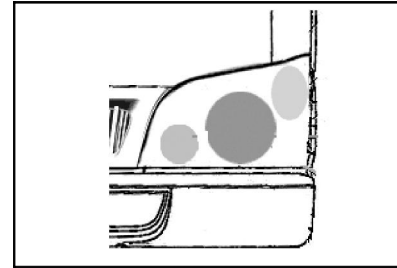

### Front light set

When replacing bulbs, take down the cover first, then the decoration bands for the headlights screw off the 4 screws, and the bulbs can be taken out.

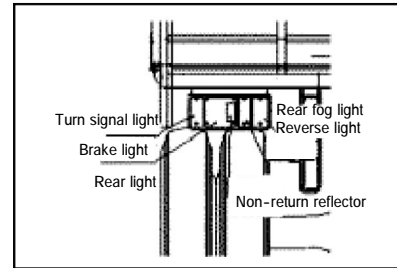

### Rear light set

When replacing the bulbs, you have to take down the tail light before taking out the bulb from behind the tail light.

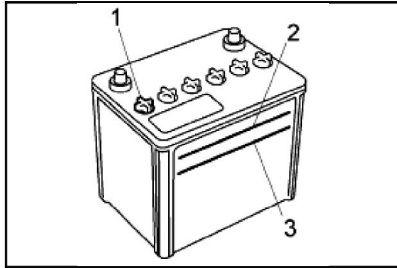

#### Battery electrolyte level

The battery electrolyte level should be between the upper and lower scale marks. If the level is too low, it is necessary to add more distilled water.

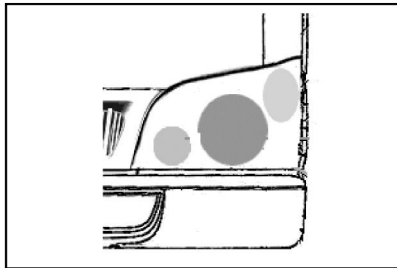

#### Headlights

Properly adjust the headlights, to ensure adequate illumination level on the highways and no dazzle lighting to drivers in other vehicles head-on. When you need to adjust the headlights, you'd better contact the authorized JAC service stations that have special equipment.

The headlights' lighting

Tighten the Screw A for vertical adjustment, and tighten Screw B for horizontal adjustment.

#### Replacement of bulbs

The removable parts of all lamps are illustrated respectively for reference.

The switches must be turned off when replacing the bulbs and only bulbs of the same rating can be used. The standard bulb ratings are listed below:

User	Power(W)	User	Power(W)	User	Power(W)
Front windshield wiper	60	Rear fog light	25	Brake light	25x2
Front fog light	55x2	High beam	60x2	Low beam	55x2
Reverse light	20x2	CD set	80	Electric horn	42
Marker light	10x5	Blower	120	Turn signal light	21x4
Ceiling light	10	Instruments	70	Others	30

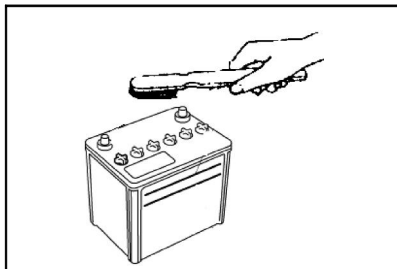

#### Washing of battery

If the exterior parts of the battery are dirty, use warm water to wash them. To prevent corrosion, apply a thin layer of Vaseline or grease to the surface of the terminal stud of the battery.

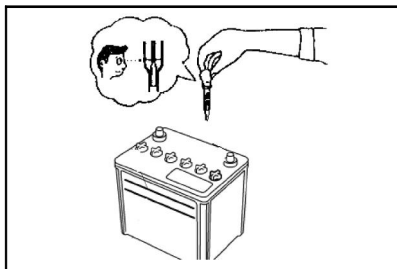

#### Specific gravity of the battery electrolyte

If the electrolyte hydrometer reads 1.26 at 20°C, it can be deemed that the battery is fully charged.

If the specific gravity is lower than 1.23, the battery needs recharging.

## Recommended brands of lubricants and diesels

For the best performance and the longest service life of your vehicle, proper brands of lube oils and diesels should be used according to the recommendation in the list below.

Location	Oil products recommended	Quantity
Engine oil sump	diesel engine lube oil Above CE class For the viscosity, refer to the list of engine lube oil viscosity vs. temperature	6
Gearbox	Summer: GL-4/85W-90	2.7
	Winter: GL-4/80W-90	
Power steering gear	Auto gearbox oil	As needed
Rear axle	Medium load automotive gear oil Class GL-4 For the viscosity, refer to the list of gear oil viscosity vs. temperature	3.5
Brake fluid reservoir	DOT3 or DOT4	As needed
Clutch fluid reservoir	DOT3 or DOT4	As needed
Wheel bearings	Multipurpose grease or lithium-based wheel bearing grease	As needed
Intermediate bearing of drive shaft	No.2 or 3 universal lithium-based grease for automobiles	As needed
Clutch yoke	No.2 or 3 universal lithium-based grease for automobiles	As needed
Drive shaft slide bushing	Foss EPT-2.5 grease	As needed
Driving universal joint	Foss EPT-2.5 grease	As needed
Engine cooling system	Glycol anti-freezing fluid with preservative	As needed
Fuel tank	Summer: No.0 quality light diesel Winter: No.-10 quality light diesel Ambient temperature below -30°C: No.-35 quality light diesel	92



## Lubrication

Lube oils must be selected and used carefully according to the lubricated points, and it is especially important to select proper lube oil viscosity according to the ambient temperature;

Table of diesel viscosity for diesel engines

Infill diesel engine lube oil

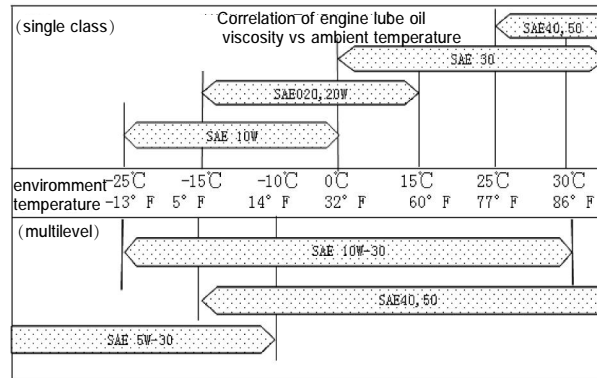
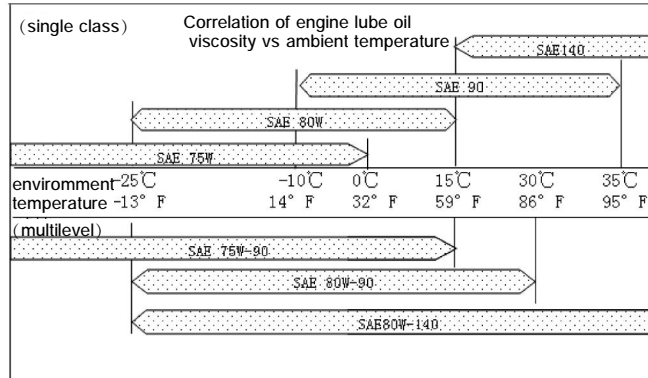
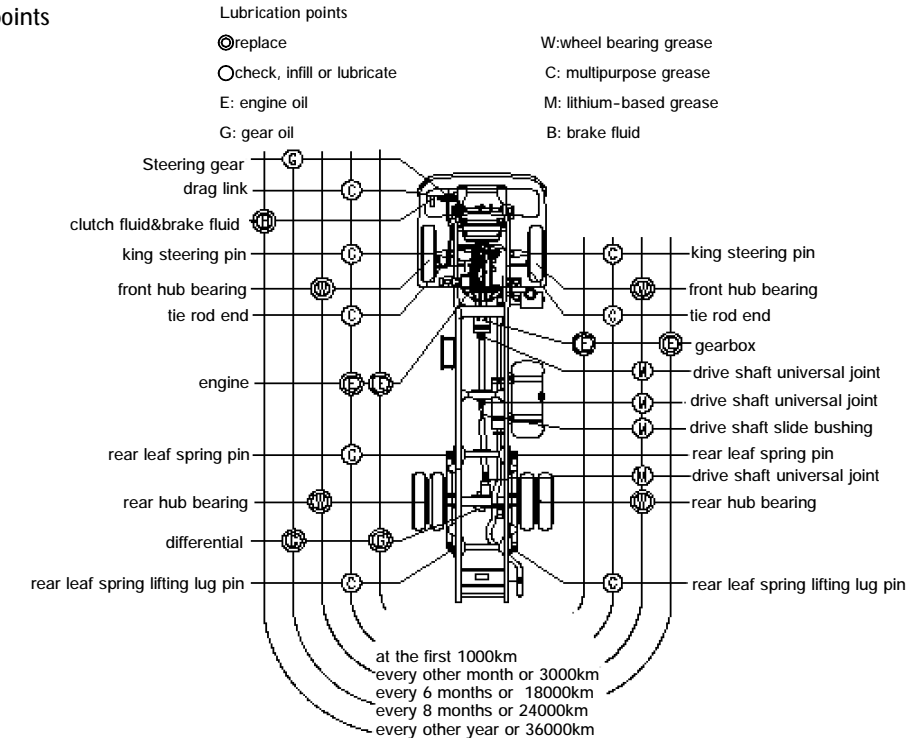

Table of gear oil viscosity

Infill gear oil



## List of lubrication points



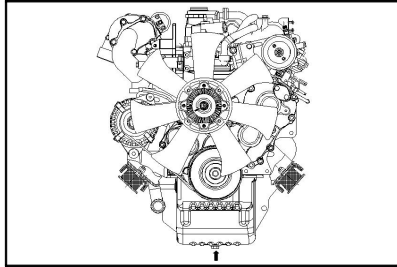

#### Guide to lubrication

##### Change of the engine oil

Remove the drain plug in the lower part of the oil sump, and drain away the engine oil in the engine crankcase.

Retighten the drain plug after complete drainage of the engine oil in the engine crankcase and the fuel filter.

Afterwards, pour the new engine oil of the specified grade into the engine crankcase through the oil filling port in the cylinder head. Note: Hot engine oil may scald skins, so please wait for the engine to cool down before draining oil.

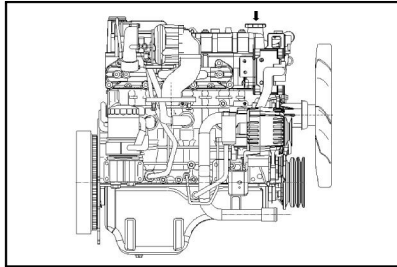

The engine oil surface level in the oil sump is measured by the dipstick fixed on the inner side of the engine. When measuring, the engine should not be running, wait for the oil surface to become still before pulling out the dipstick, and wipe off the oil from the dipstick with clean cotton cloth. Dip the dipstick into the oil sump again to the bottom, and then pull it out to check the oil level. There are two scale lines on the dipstick, the engine oil level should not be below the lower scale, or there will be difficult oil supply. But the engine oil level should not be over the upper scale line, otherwise there will occur carbon deposition, fumes and oil permeation, etc. Therefore, apart from constant attention to the

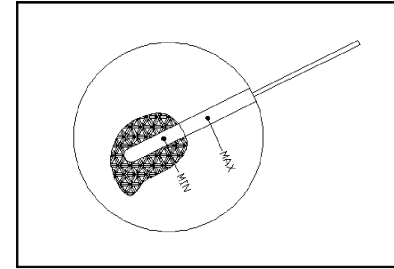

normality of the engine oil pressure, the engine oil surface level should be checked before driving out and at an interval of 300-500km.

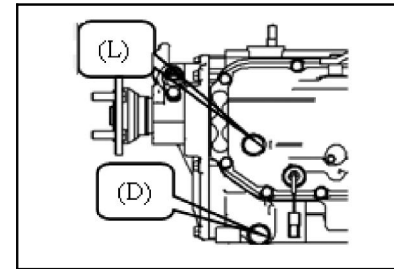

##### Replacement of gearbox oil

Screw off the drain hole plug (D) in the bottom of the gearbox casing, drain the oil out of the gearbox casing. Then, infill the specified lubricant oil into the gearbox casing through the level inspection hole, until the oil level goes up to the screw plug (L) of the level inspection hole.

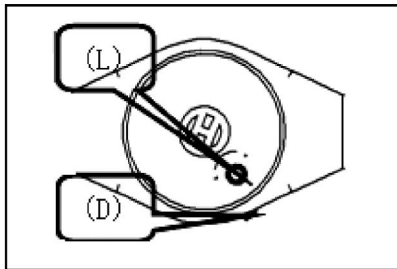

#### Replacement of differential oil

Screw off the drain hole plug (D) in the bottom of the rear axle case to drain the gear oil in it, infill the specified gear oil into the rear axle case through the level inspection hole, until the oil level goes up to the screw plug (L) of the level inspection hole.

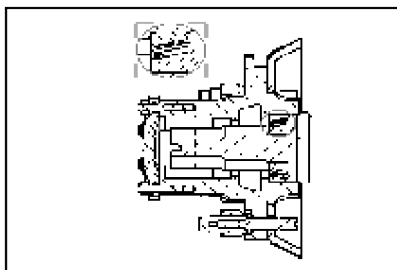

#### Replacement of the greases for the front and rear hub bearings

Replacement of the greases for the front and left hub bearings needs disassembly and reassembly of the bearings, so please entrust the authorized JAC service stations to do that. Proper maintenance and driving can prolong the vehicle service life, but also can improve the fuel and oil economic efficiency.

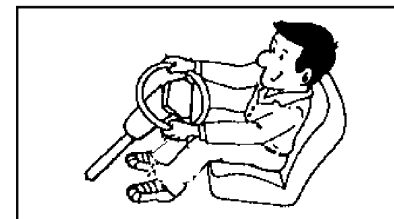

#### Replacement of steering oil and fluid

##### Exhaust fluid

1. Jack up the front axle off the ground completely.
2. Remove the oil pipes (2 pieces) between the steering gear and the power steering oil reservoir.
3. After the steering fluid is drained off, start the engine in short time, turn the steering wheel right and left to its limit positions without over 15 seconds, until the residual fluid is completely drained from the steering pipes.

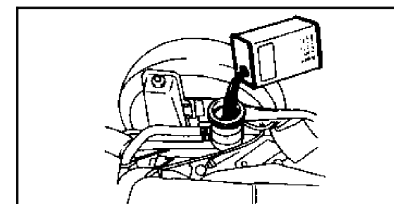

##### New fluid fill-up

1. Fix the removed oil pipe in the oil pot and infill the specified power steering fluid.
2. Fill in the power steering fluid up between the scale marks in the oil pot. Take care that the fluid surface sinks in parallel with the fill-up, so as to keep a stable level against any air trapped in.
3. Lower down the front wheels onto the ground, start the engine into idle speed for several minutes, and rotate the steering wheel right and left.
4. Check the level against the scale mark, and add some more if needed.

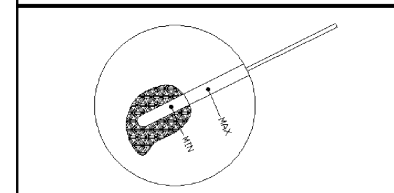

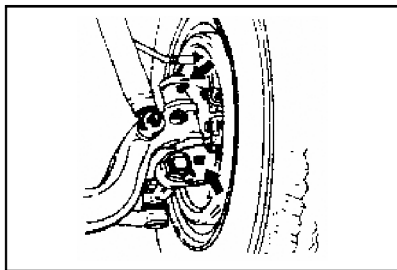

Lubrication points  
Please use multipurpose greases for lubrication of the following points.  
King steering pins (4)

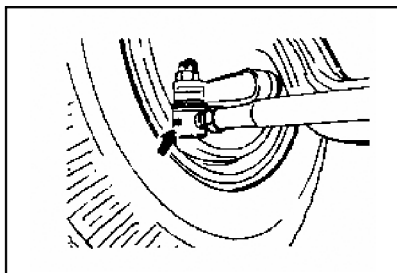

Ends of tie rod (2)

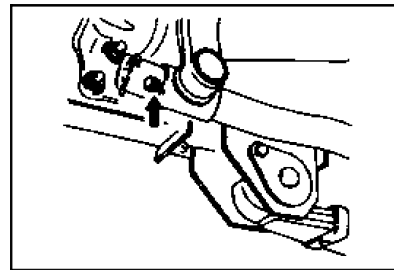

Drag link (2)

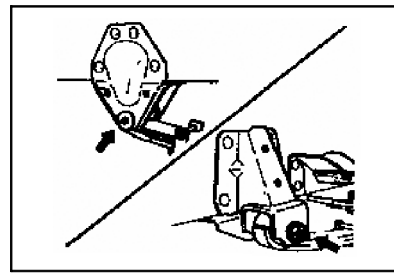

Rear leaf spring and spring pin (2)

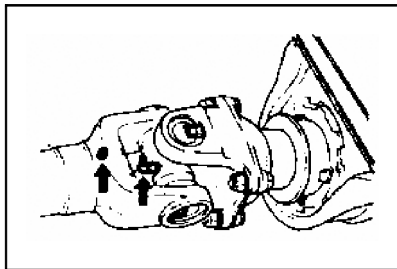

Apply Foss EPT-2.5 grease to the following points:  
Universal joints and slide bushing

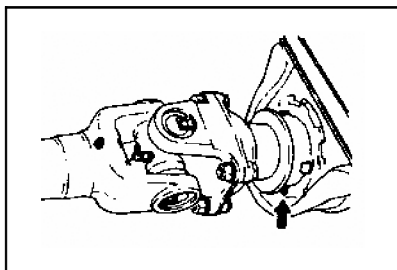

Please apply No.2 or 3 universal automobile lithium-based grease to the following parts:  
Intermediate bearings

## Technical specification

### Technical specification

Model	HFC1035KD	HFC1035KD	HFC1042K2RD	HFC1042K3RT
Cabin	Single Cab	Single Cab	Double Cab	Double Cab
Engine	HFC4DA1(E-I)	HFC4DA1-1(E-II)	HFC4DA1-1(E-II)	HFC4DA1-2B(E-III)
Type	in line-4, diesel	in line-4, ind-cooler turbocharged, diesel	in line-4, ind-cooler turbocharged, diesel	in line-4, ind-cooler turbocharged, diesel
Displacement (cc)	2771	2771	2771	2771
Compression Ratio	17	17	17	17
Max Power (kw/rpm)	57/3600	68/3600	68/3600	68/3600
Max Torque (N.m/rpm)	174/2100-2300	202/2100-2300	202/2100-2300	202/2100-2300
Transmission	JAC MSB-5M	JAC MSB-5M	JAC MSB-5M	JAC MSB-5M
Speed Ratio	5.529, 2.782, 1.641, 1, 0.785, R, 5.271	5.529, 2.782, 1.641, 1, 0.785, R, 5.271	5.529, 2.782, 1.641, 1, 0.785, R, 5.271	5.529, 2.782, 1.641, 1, 0.785, R, 5.271
Gear Position	1 3 5 2 4 R	1 3 5 2 4 R	1 3 5 2 4 R	1 3 5 2 4 R
Final gear ratio	5.375	5.375	5.375	5.375
Brake system	hydraulic brake	hydraulic brake	hydraulic brake	hydraulic brake
Tyre	7.00R16 Rear single	7.00R16 Rear single	7.00R16 Rear single	7.00R16 Rear single
Overall Size(mm) (L*W*H)	4850*1730*224	4850*1730*2240	4875*1715*2215	4918*1868*2154
Rear body size(mm)(L*W*H)	3120*1620*400	3120*1620*400	2080*1620*400	2080*1770*400
Tread (front /rear )(mm)	1385/1395	1385/1395	1385/1395	1385/1395
Wheelbase(mm)	2490	2490	2490	2490
Min Turing Radius(m)	6	6	6	6
Min Ground Clearance(mm)	198	198	198	198
Max Speed(km/h)	110	110	110	110
Seating Capacity	2	2	2+3	2
Max Gradeability(%)	35	35	35	35

Model	HFC1042K3T	HFC1045KRD	HFC1045KRD	HFC1040K/KR1
Cabin	Single Cab	Double Cab	Double Cab	Single/King Cab
Engine	HFC4DA1-2B(E-III)	HFC4DA1-2B(E-III)	HFC4DA1-1(E-II)	HFC4DA1-1(E-II)
Type	型式 in line-4, ind-cooler turbocharged, diesel	in line-4, ind-cooler turbocharged, diesel	in line-4, ind-cooler turbocharged, diesel	in line-4, ind-cooler turbocharged, diesel
Displacement (cc)	2771	2771	2771	2771
Compression Ratio	17	17.5	17.5	17
Max Power (kw/rpm)	68/3600	68/3600	68/3600	68/3600
Max Torque (N.m/rpm)	202/2100-2300	202/2100-2300	202/2100-2300	202/2100-2300
Transmission	JAC MSB-5M	JAC MSB-5M	JAC MSB-5M	JAC MSB-5M
Speed Ratio	5.529, 2.782, 1.641, 1, 0.785, R, 5.271	5.529, 2.782, 1.641, 1, 0.785, R, 5.271	5.529, 2.782, 1.641, 1, 0.785, R, 5.271	5.529, 2.782, 1.641, 1, 0.785, R, 5.271
Gear Position	1 3 5 2 4 R	1 3 5 2 4 R	1 3 5 2 4 R	1 3 5 2 4 R
Final gear ratio	5.375	B301-4.875	B301-4.875	D803-6.142
Brake system	hydraulic brake	hydraulic brake	hydraulic brake	hydraulic brake
Tyre	7.00R16 Rear single	6.50-16/6.50R16	6.50-16/6.50R16	6.50-16
Overall Size(mm) (L*W*H)	4850*1730*2240	5320*1880*2150	5320*1880*2150	5745*1866*2213
Rear body size(mm)(L*W*H)	3120*1620*400	2540*1770*400	2540*1770*400	3930/3600*1770*400
Tread (front /rear )(mm)	1385/1395	1580/1395	1580/1395	1420,1440/1395
Wheelbase(mm)	2490	2800	2800	3000
Min Turing Radius(m)	6	7	7	7
Min Ground Clearance(mm)	198	190	190	185
Max Speed(km/h)	110	95	95	90
Seating Capacity	2	2+3	2+3	2
Max Gradeability(%)	35	32	32	30

Model	HFC1040K/KR1	HFC1045K9T/K9R1T	HFC1045K9T/K9R1T	HFC1045K9/K9R1
Cabin	Single/King Cab	Single/King Cab	Single/King Cab	Single/King Cab
Engine	HFC4DA1(E-I)	HFC4DA1-2B(E-III)	HFC4DA1-2B1(E-III)	HFC4DA1-1A(E-II)
Type	in line-4,diesel	in line-4, ind-cooler turbocharged, diesel	in line-4, ind-cooler turbocharged, diesel	in line-4, ind-cooler turbocharged, diesel
Displacement (cc)	2771	2771	2771	2771
Compression Ratio	17	17.5	17.5	17.5
Max Power (kw/rpm)	57/3600	68/3600	80/3600	80/3600
Max Torque (N.m/rpm)	174/2100-2300	202/2100-2300	220/2100-2300	220/2100-2300
Transmission	JAC MSB-5M	JAC MSB-5M	JAC MSB-5M	JAC MSB-5M
Speed Ratio	5.529, 2.782, 1.641, 1, 0.785, R, 5.271	5.529, 2.782, 1.641, 1, 0.785, R, 5.271	5.529, 2.782, 1.641, 1, 0.785, R, 5.271	5.529, 2.782, 1.641, 1, 0.785, R, 5.271
Gear Position	1 3 5 2 4 R	1 3 5 2 4 R	1 3 5 2 4 R	1 3 5 2 4 R
Final gear ratio	D803-6.142	B1DAB0-5.571	B1DAB0-5.571	B1DAB0-5.571
Brake system	hydraulic brake	hydraulic brake	hydraulic brake	hydraulic brake
Tyre	6.50-16	6.50R16/6.50-16	6.50R16/6.50-16	6.50R16/6.50-16
Overall Size(mm) (L*W*H)	5745*1866*2213	5980*1998*2220	5980*1998*2220	5980*1998*2220
Rear body size(mm)(L*W*H)	3930/3600*1770*400	4180/3850*1900*400	4180/3850*1900*400	4180/3850*1900*400
Tread (front /rear )(mm)	1420,1440/1395	1580/1395	1580/1395	1580/1395
Wheelbase(mm)	3000	3308	3308	3308
Min Turing Radius(m)	7	14	14	14
Min Ground Clearance(mm)	185	185	185	185
Max Speed(km/h)	90	95	95	95
Seating Capacity	2	3	3	3
Max Gradeability(%)	30	30	30	30

Model	HFC1045K2/R1	HFC1045K2	HFC1042K
Cabin	Single/King Cab	Single/King Cab	Single Cab
Engine	HFC4DA1-1(E-II)	HFC4DA1(E-I)	HFC4DA1(E-I)
Type	in line-4, ind-cooler turbocharged, diesel	in line-4, diesel	in line-4,diesel
Displacement (cc)	2771	2771	2771
Compression Ratio	17.5	17	17
Max Power (kw/rpm)	68/3600	57/3600	57/3600
Max Torque (N.m/rpm)	202/2100-2300	174/2100-2300	174/2100-2300
Transmission	JAC MSB-5M	JAC MSB-5M	JAC MSB-5M
Speed Ratio	5.529, 2.782, 1.641, 1, 0.785, R, 5.271	5.529, 2.782, 1.641, 1, 0.785, R, 5.271	5.529, 2.782, 1.641, 1, 0.785, R, 5.271
Gear Position	1 3 5 2 4 R	1 3 5 2 4 R	1 3 5 2 4 R
Final gear ratio	B1DAB0-5.571	B1DAB0-6.142	D800-6.142
Brake system	hydraulic brake	hydraulic brake	hydraulic brake
Tyre	6.50R16/6.50-16	6.50R16/6.50-16	7.00R16
Overall Size(mm) (L*W*H)	5980*1998*2220	5980*1998*2200	5980*1880*2200
Rear body size(mm)(L*W*H)	4180/3850*1900*400	4180/3850*1900*400	4180*1770*380
Tread (front /rear )(mm)	1580/1395	1580/1395	1440/1425
Wheelbase(mm)	3308	3308	3360
Min Turing Radius(m)	14	7	7
Min Ground Clearance(mm)	185	185	190
Max Speed(km/h)	95	95	100
Seating Capacity	3	3	2
Max Gradeability(%)	30	30	30

Model	HFC1040K2	HFC1042KR	HFC1042K2T/K2RT	HFC1042K
Cabin	Single/King Cab	Double Cab	Single/King Cab	Double Cab
Engine	HFC4DA1-1(E-II)	HFC4DA1-1(E-II)	HFC4DA1-2B(E-III)	HFC4DA1-2B(E-III)
Type	in line-4, ind-cooler turbocharged, diesel	in line-4, ind-cooler turbocharged, diesel	in line-4, ind-cooler turbocharged, diesel	in line-4, ind-cooler turbocharged, diesel
Displacement (cc)	2771	2771	2771	2771
Compression Ratio	17	17	17	17
Max Power (kw/rpm)	68(80)/3600	68(80)/3600	68/3600	68/3600
Max Torque (N.m/rpm)	202(240)/2100-2300	202(240)/2100-2300	68kw/3600	202/2100-2300
Transmission	JAC MSB-5M	JAC MSB-5M	JAC MSB-5M	JAC MSB-5M
Speed Ratio	5.529, 2.782, 1.641, 1, 0.785, R, 5.271	5.529, 2.782, 1.641, 1, 0.785, R, 5.271	5.529, 2.782, 1.641, 1, 0.785, R, 5.271	5.529, 2.782, 1.641, 1, 0.785, R, 5.271
Gear Position	1 3 5 2 4 R	1 3 5 2 4 R	1 3 5 2 4 R	1 3 5 2 4 R
Final gear ratio	D800-6.142	D800-6.142	D800-6.142	D800-6.142
Brake system	hydraulic brake	hydraulic brake	hydraulic brake	hydraulic brake
Tyre	7.00R16	7.00R16	7.00R16	7.00R16
Overall Size(mm) (L*W*H)	5995*1900*2250	5995*1900*2250	5995*1900*2250	5995*1900*2250
Rear body size(mm)(L*W*H)	4230/3900*1790*400	3200*1790*400	4230/3900*1790*400	*1790*400
Tread (front /rear )(mm)	1440/1425	1440/1425	1440/1425	1440/1425
Wheelbase(mm)	3360	3360	3360	3360
Min Turing Radius(m)	7	7	7	7
Min Ground Clearance(mm)	190	190	190	190
Max Speed(km/h)	100	100	100	100
Seating Capacity	2	2+3	2	2
Max Gradeability(%)	30	32	30	30

## Technical specification

Model	HFC1042K2T/K2RT	HFC1042K	HFC1035KD	HFC1020K/KR1
Cabin	Single/King Cab	Double Cab	Single Cab	Single/King Cab
Engine	HFC4DA1-2B1(E-III)	HFC4DA1-2B1(E-III)	HFC4DA1-1(E-II)	HFC4DA1(E-I)
Type	in line-4, ind-cooler turbocharged, diesel	in line-4, ind-cooler turbocharged, diesel	in line-4, ind-cooler turbocharged, diesel	in line-4, diesel
Displacement (cc)	2771	2771	2771	2771
Compression Ratio	17	17	17	17
Max Power (kw/rpm)	80/3600	80/3600	92/3600	77/3600
Max Torque (N.m/rpm)	202/2100-2300	202/2100-2300	202/2100-2300	174/2100-2300
Transmission	JAC MSB-5M	JAC MSB-5M	JAC MSB-5M	JAC MSB-5M
Speed Ratio	5.529, 2.782, 1.641, 1, 0.785, R, 5.271	5.529, 2.782, 1.641, 1, 0.785, R, 5.271	5.529, 2.782, 1.641, 1, 0.785, R, 5.271	5.529, 2.782, 1.641, 1, 0.785, R, 5.271
Gear Position	1 3 5 2 4 R	1 3 5 2 4 R	1 3 5 2 4 R	1 3 5 2 4 R
Final gear ratio	D800-6.142	D800-6.142	5.375	D870-6.142
Brake system	hydraulic brake	hydraulic brake	hydraulic brake	hydraulic brake
Tyre	7.00R16	7.00R16	7.00R16 Rear single	hydraulic brake
Overall Size(mm) (L*W*H)	5995*1900*2250	5995*1900*2250	4850*1730*2240	5400*1868*2200
Rear body size(mm)(L*W*H)	4230/3900*1790*400	*1790*400	3120*1620*400	3580/3250*1710*370
Tread (front /rear )(mm)	1440/1425	1440/1425	1385/1395	1440/1395
Wheelbase(mm)	3360	3360	2490	2800
Min Turing Radius(m)	7	7	6	6
Min Ground Clearance(mm)	190	190	198	185
Max Speed(km/h)	100	100	110	90
Seating Capacity	2	2	2	2
Max Gradeability(%)	30	30	35	30