

TECHNICAL MANUAL
ORGANIZATIONAL MAINTENANCE MANUAL
VOLUME 3 OF 3

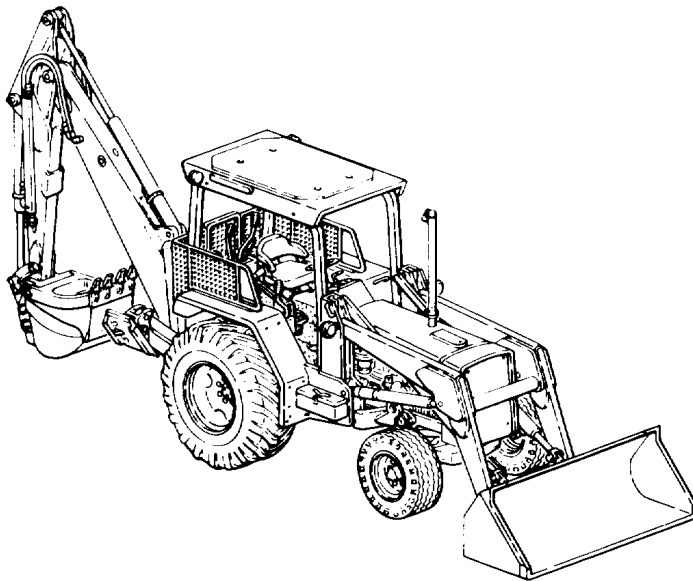

**MAINTENANCE
INSTRUCTIONS -
CONTINUED
PAGE 2-1189**

**MAINTENANCE
ALLOCATION
CHART (MAC)
PAGE B-1**

**INDEX
PAGE Index-1**

**TRACTOR, WHEELED (DED)
LOADER BACKHOE
W/HYDRAULIC IMPACT TOOL AND
HYDRAULIC EARTH AUGER ATTACHMENT
JOHN DEERE MODEL JD 410 (CCE)
WITH BUCKET, IMPACTOR,
AND EARTH DRILL
(NSN 2420-00-567-1035)**

APPROVED FOR PUBLIC RELEASE; DISTRIBUTION IS UNLIMITED

**This copy is a reprint which includes current
pages from Change 1.**

Change 1

1 SEPTEMBER 1987

HEADQUARTERS, DEPARTMENT OF THE ARMY

WARNING

When operating loader backhoe, make sure that all personnel are cleared from vehicle and work area. Failure to observe this precaution could cause injury to personnel.

WARNING

Do not operate backhoe controls unless you are in operator's seat facing backhoe. Backhoe boom cylinder may be accidentally bumped, causing backhoe boom to move suddenly. Failure to observe this precaution could cause serious injury.

WARNING

Do not attempt to disconnect hydraulic lines and fittings while engine is running or before hydraulic system pressure has been released. When engine is running, hydraulic system is under pressure. Hydraulic system pressure should be 0 psi (0 kPa) before lines are disconnected. A line or fitting disconnected under pressure will blow off with a lot of force and could cause serious injury to personnel.

WARNING

Be careful when draining hot fluids. Wear gloves to protect your hands from hot parts and fluids or severe burns could result.

WARNING

Drycleaning solvent P-D-680 is toxic and flammable. Wear protective goggles and gloves and use only in a well ventilated area. Avoid contact with skin, eyes, and clothes and don't breathe vapors. Do not use near open flame or excessive heat. The flashpoint is 100°F to 138°F (38° to 59°C). If you become dizzy while using cleaning solvent, get fresh air immediately and get medical aid. If contact with eyes is made, wash your eyes with water and get medical aid immediately.

WARNING

Compressed air used for blowing away chips, dirt, etc., must leave nozzle at less than 30 psi (207 kPa) to prevent personal injury. Be certain that nozzle is rated to provide a maximum of 30 psi (207 kPa). Be sure to wear safety goggles when using compressed air. Compressed air and particles moved by compressed air can cause damage to your eyes.

WARNING

Be careful of moving parts when working near engine while it is running. Moving parts could catch on tools, clothing, or extremities causing serious injury.

WARNING

Keep clear of hydraulic components when raised and not supported. Sudden loss of hydraulic pressure could cause components to drop without warning.

WARNING

Surge relief valve plug is under strong spring tension. If plug is not supported, parts may fly off injuring personnel.

WARNING

Valve is under strong spring tension. If valve is not supported when mounting bolts are removed, parts may fly off injuring personnel.

WARNING

Some parts are heavy. Be careful when handling them. Lifting equipment is needed when parts weigh over 50 pounds (23 kg) for a single person lift, over 100 pounds (45 kg) for a two person lift, and over 150 pounds (68 kg) for a three or more person lift. Do not try to handle heavy parts without lifting equipment. Keep clear of heavy parts supported only by lifting equipment. Failure to observe this precaution could cause serious injury or death of personnel.

Change 1 b

CHANGE

NO. 1

HEADQUARTERS
DEPARTMENT OF THE ARMY
Washington D.C., 8 April 1992

ORGANIZATIONAL MAINTENANCE MANUAL

**TRACTOR, WHEELED,
DED, LOADER BACKHOE:
WITH HYDRAULIC IMPACT TOOL AND
WITH HYDRAULIC EARTH AUGER ATTACHMENT
JOHN DEERE MODEL JD410 (CCE)
WITH BUCKET, IMPACTOR,
AND EARTH DRILL
(NSN 2420-00-567-0135)**

TM 5-2420-222-20-3, 1 September 1987, is changed as follows:

1. Cover. The manual title is changed to read as shown above.
2. Remove old pages and insert new pages.
3. New or changed material is indicated by a vertical bar in the margin or by a vertical bar adjacent to the TA number.

Remove Pages

*a and b
i and ii
A-1 and A-2
Appendix B (in its entirety)
C-3 and C-4
Cover 1 and 2*

Insert Pages

*a and b
i and ii
A-1 and A-2
Appendix B (in its entirety)
C-3 and C-4
Cover 1 and 2*

4. File this change sheet in front of the publication for reference purposes.

Approved for public release; distribution is unlimited.

By Order of the Secretary of the Army:

Official

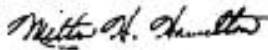

MILTON H. HAMILTON
*Administrative Assistant to the
Secretary of the Army*
00776

GORDON R. SULLIVAN
*General, United States Army
Chief of Staff*

Distribution:

To be distributed in accordance with DA Form 12-25-E, Block 3692, Unit maintenance requirements for TM 52420-222-20-3.

TECHNICAL MANUAL

NO. 5-2420-222-20-3

HEADQUARTERS
DEPARTMENT OF THE ARMY
WASHINGTON, D.C., 1 September 1987

ORGANIZATIONAL MAINTENANCE MANUAL

TRACTOR, WHEELED,
DED, LOADER BACKHOE:
WITH HYDRAULIC IMPACT TOOL AND
WITH HYDRAULIC EARTH AUGER ATTACHMENT
JOHN DEERE MODEL JD410 (CCE)
WITH BUCKET, IMPACTOR,
AND EARTH DRILL
(NSN 2420-00-567-0135)

REPORTING ERRORS AND RECOMMENDING IMPROVEMENTS

You can help improve this manual. If you find any mistakes or if you know of a way to improve the procedures, please let us know. Mail your letter, DA Form 2028 (Recommended Changes to Publications and Blank Forms), or DA Form 20282 located in the back of this manual direct to: Commander, US Army Tank-Automotive Command, ATTN: AMSTA-MB, Warren, MI 48397-5000. A reply will be sent to you.

TABLE OF CONTENTS

VOLUME 3 OF 3

	Page
CHAPTER 2	MAINTENANCE INSTRUCTIONS - CONTINUED 2-1189
Section XX.	Hydraulic and Fluid Systems..... 2-1189
Section XXI.	Gages, (Non-Electrical), Weighing and Measuring Devices 2-1785
Section XXII.	Cranes, Shovels, and Earthmoving Equipment Components 2-1795
Section XXIII.	Fire Fighting Equipment Components..... 2-1851
Section XXIV.	Parts Peculiar 2-1855
Section XXV.	Preparation for Storage or Shipment 2-1897
APPENDIX A	REFERENCES..... A-1

*This manual supersedes Organizational portion of TM 5-2420-222-14&P1 and TM 5-2420-222-14&P2 dated October 1982, including all changes.

Approved for public release; distribution is unlimited.

TABLE OF CONTENTS - CONTINUED

VOLUME 3 OF 3 - CONTINUED

		Page
APPENDIX B	<u>MAINTENANCE ALLOCATION CHART</u>	B-1
Section I.	Introduction.....	B-1
Section II.	Maintenance Allocation Chart	B-4
Section III.	Tools and Test Equipment Requirements	B-23
Section IV.	Remarks	B-25
APPENDIX C	EXPENDABLE SUPPLIES AND MATERIALS LIST	C-1
Section I.	Introduction.....	C-1
Section II.	Expendable Supplies and Materials List	C-2
APPENDIX D	ILLUSTRATED LIST OF MANUFACTURED ITEMS	D-1
APPENDIX E	TORQUE LIMITS	E-1
INDEX	Index-1

Section XX. HYDRAULIC AND FLUID SYSTEMS

	Page		Page
Backhoe Bucket Cylinder	2-1726	Hydraulic Impactor Flow Regulator-	
Backhoe Control Valve.....	2-1260	to-Boom Oil Line (Serial Numbers	
Backhoe Control Valve Levers and		235786 thru 235999 Only)	2-1499
Linkage (Serial Numbers 235786		Hydraulic Impactor Flow Regulator-	
thru 235999 Only).....	2-1302	to-Boom Oil Line (Serial Numbers	
Backhoe Control Valve Levers and		319995 thru 342573 Only)	2-1505
Linkage (Serial Numbers 319995		Hydraulic Impactor Valve	2-1228
thru 342573 Only).....	2-1314	Hydraulic Oil Cooler-to-Clutch	
Backhoe Control Valve-to-Backhoe		Control Valve Oil Line	2-1361
Stabilizer Cylinder Oil Lines.....	2-1622	Hydraulic Oil Filter.....	2-1698
Backhoe Control Valve-to-Backhoe		Hydraulic Oil Filter Relief	
Swing Cylinder Oil Lines	2-1636	Valve	2-1217
Backhoe Control Valve-to-Jaw		Hydraulic Oil Filter Relief Valve-	
Direct Linear Valve Oil Line		to-Clutch Control Valve Adapter	
(Serial Numbers 319995 thru		Oil Line.....	2-1346
342573 Only).....	2-1412	Hydraulic Pump Pressure Line Tee-	
Backhoe Control Valve-to-Manifold		to-Hydraulic Accumulator Oil	
Block Oil lines.....	2-1558	Line	2-1384
Backhoe Control Valve-to-Manifold		Hydraulic Pump-to-Hydraulic Oil	
Oil Lines (Serial Numbers 235786		Cooler Hose (Serial Numbers	
thru 235999 Only).....	2-1429	319995 thru 342573 Only)	2-1338
Backhoe Crowd Cylinder.....	2-1740	Hydraulic Pump-to-Hydraulic Oil	
Backhoe Stabilizer Cylinders.....	2-1752	Cooler Oil Line (Serial Numbers	
Backhoe Swing Cylinders.....	2-1708	235786 thru 235999 Only)	2-1342
Boom-to-Backhoe Control Valve		Hydraulic Pump-to-Pressure	
Hydraulic Impactor Return Oil Line		Control Valve Oil Line	2-1375
(Serial Numbers 319995 thru		Hydraulic Pump-to-Speed Gear	
342573 Only).....	2-1489	Assembly (Reverser) Seal Drain	
Boom-to-Bucket Cylinder Oil Lines		Line	2-1369
(Serial Numbers 235786 thru		Hydraulic System Diagram (Serial	
235999 Only).....	2-1598	Numbers 235786 thru 235999	
Boom-to-Bucket Cylinder Oil Lines		Only)	2-1779
(Serial Numbers 319995 thru		Hydraulic System Diagram (Serial	
342573 Only).....	2-1608	Numbers 319995 thru 342573	
Boom-to-Jaw Cylinder Oil Hose Oil		Only)	2-1782
Lines (Serial Numbers 235786 thru		Hydraulic System Pressure	
235999 Only).....	2-1532	Release.....	2-1191
Boom-to-Jaw Cylinder Oil Hose Oil		Jaw Control (Direct Linear) Valve	
Lines (Serial Numbers 319995 thru		Bracket.....	2-1298
342573 Only).....	2-1538	Jaw Control (Direct Linear) Valve	
Boom-to-Manifold Hydraulic Impactor		Linkage	2-1294
Return Oil Line (Serial Numbers		Jaw Control (Direct Linear) Valve-	
235786 thru 235999 Only).....	2-1483	to-Manifold Block Oil Lines	2-1513
Clutch Control Valve-to-Hydraulic		Jaw Control (Direct Linear) Valve	
Pump Inlet Oil Line.....	2-1352	Tubes and Fittings	2-1391
Hydraulic Accumulator Charging.....	2-1194	Jaw Control Valve (Serial Numbers	
Hydraulic Earth Drill Bleed Oil		235786 thru 235999 Only)	2-1242
Line.....	2-1550	Jaw Cylinder.....	2-1703
Hydraulic Impactor Flow		Jaw Cylinder Oil Hoses	2-1544
Regulator.....	2-1237		

Section XX. HYDRAULIC AND FLUID SYSTEMS - CONTINUED

	Page		Page
Jaw Direct Linear Valve (Serial Numbers 319995 thru 342573 Only).....	2-1250	Manifold Block-to-Boom Jaw Control Oil Tubes (Serial Numbers 319995 thru 342573 Only)	2-1526
Jaw Direct Linear Valve-to-Backhoe Control Valve Oil Line (Serial Numbers 319995 thru 342573 Only).....	2-1436	Manifold Block-to-Crowd Cylinder Oil Lines (Serial Numbers 235786 thru 235999 Only)	2-1570
Jaw Direct Linear Valve-to-Hydraulic Impactor Valve Oil Line (Serial Numbers 319995 thru 342573 Only).....	2-1421	Manifold Block-to-Crowd Cylinder Oil Lines (Serial Numbers 319995 thru 342573 Only)	2-1578
Jaw Direct Linear Valve-to-Hydraulic Oil filter Relief Valve Oil Line (Serial Numbers 319995 thru 342573 Only).....	2-1464	Manifold Block-to-Head End Boom Cylinder Oil Line.....	2-1565
Loader Boom Cylinders.....	2-1770	Manifold-to-Hydraulic Oil Filter Relief Valve Oil Line (Serial Numbers 235786 thru 235999 Only)	2-1450
Loader Bucket Cylinders	2-1760	Manifold-to-Hydraulic Impactor Valve Oil Line (Serial Numbers 235786 thru 235999 Only)	2-1440
Loader Control Valve.....	2-1285	Manifold-to-Jaw Control Valve Oil Lines (Serial Numbers 235786 thru 235999 Only)	2-1456
Loader Control Valve Handle and Linkage.....	2-1324	Pressure Control Valve	2-1200
Loader Control Valve Mounting Bracket.....	2-1282	Pressure Control Valve-to-Jaw Direct Linear Valve Oil Line (Serial Numbers 319995 thru 342573 Only)	2-1405
Loader Control Valve-to-Hydraulic Oil Filter Relief Valve Oil Line.....	2-1653	Pressure Control Valve-to-Loader Control Valve Oil Line	2-1647
Loader Control Valve-to-Loader Boom Cylinder Head End Oil Lines.....	2-1679	Pressure Control Valve-to-Manifold Oil Line (Serial Numbers 235786 thru 235999 Only)	2-1400
Loader Control Valve-to-Loader Boom Cylinder Rod End Oil Lines.....	2-1688	Pump Stroke Control Valve Filter Element.....	2-1196
Loader Control Valve-to-Loader Bucket Cylinder Head End Oil Lines.....	2-1661	Quick Coupler-to-Boom Oil Lines (Serial Numbers 235786 thru 235999 Only)	2-1472
Loader Control Valve-to-Loader Bucket Cylinder Rod End Oil Lines.....	2-1670	Quick Coupler-to-Boom Oil Lines (Serial Numbers 319995 thru 342573 Only)	2-1477
Manifold Block.....	2-1270		
Manifold Block-to-Boom Bucket Cylinder Oil Lines	2-1590		
Manifold Block-to-Boom Jaw Control Oil Hoses (Serial Numbers 235786 thru 235999 Only).....	2-1522		

HYDRAULIC SYSTEM PRESSURE RELEASE

This task covers:

Hydraulic System Pressure Release (page 2-1191)

INITIAL SETUP

Personnel Required

One

LOCATION	ITEM	ACTION	REMARKS
----------	------	--------	---------

HYDRAULIC SYSTEM PRESSURE RELEASE

NOTE

Hydraulic system pressure must be released before disconnecting hydraulic lines and fittings. A line or fitting disconnected under pressure will blow off with a lot of force and could cause injury to personnel.

When engine is running, hydraulic system is under pressure. In order to release hydraulic system pressure, engine must be shut down.

There are three ways to release hydraulic system pressure. Perform any one of the following three steps to release hydraulic system pressure.

HYDRAULIC SYSTEM PRESSURE RELEASE - CONTINUED

LOCATION	ITEM	ACTION	REMARKS
----------	------	--------	---------

HYDRAULIC SYSTEM PRESSURE RELEASE - CONTINUED

- | | | | |
|---------------|-----------------------------------|--|--|
| 1. Operator's | Steering wheel (1)
compartment | Turn from side to side until steering is hard. | |
|---------------|-----------------------------------|--|--|

WARNING

When operating loader backhoe, make sure that all personnel are cleared from vehicle and work area. Failure to observe this precaution could cause injury to personnel.

- | | | | |
|----|------------------------------------|---|--|
| 2. | Loader bucket
control lever (2) | a. Pull back until loader bucket (3) stops raising.

b. Push forward until loader bucket (3) rests on ground. | |
|----|------------------------------------|---|--|

WARNING

Do not operate backhoe controls unless you are in operator's seat facing backhoe. Backhoe boom cylinder may be accidentally bumped, causing backhoe boom to move suddenly. Failure to observe this precaution could cause serious injury.

- | | | | |
|----|-----------------------------------|---|--|
| 3. | Backhoe boom
control lever (4) | a. Pull back until boom (5) stops raising.

b. Push forward until backhoe bucket (6) rests on ground. | |
|----|-----------------------------------|---|--|

HYDRAULIC SYSTEM PRESSURE RELEASE - CONTINUED

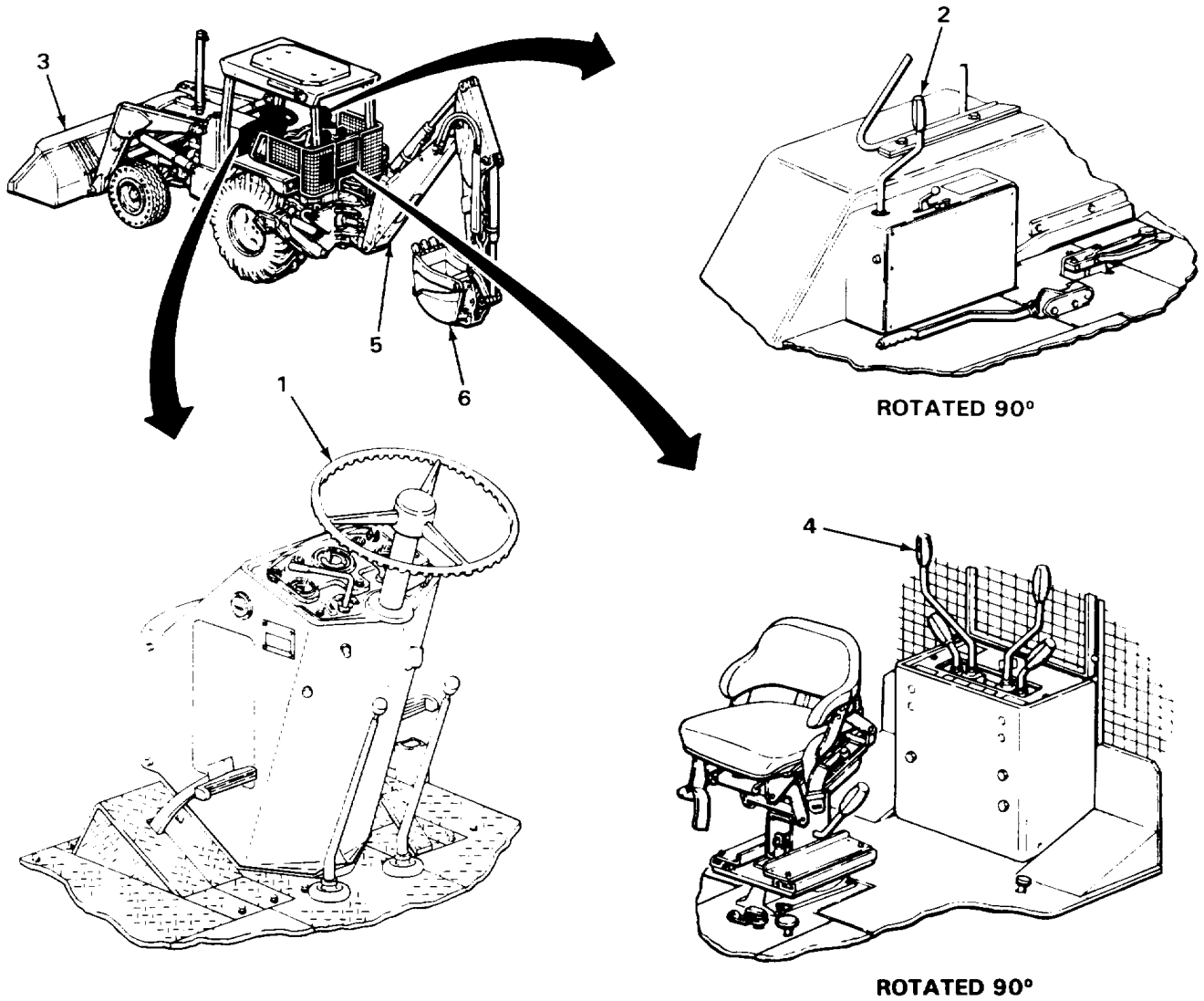

TASK ENDS HERE

TA243304

HYDRAULIC ACCUMULATOR CHARGING

This task covers:

Charging (page 2-1194)

INITIAL SETUP

Tools

Charging kit, accumulator,
Nudie ND-925-0 (-W)
Connector, John Deere R40617
Hose, John Deere AR47753
Knife, pocket
Wrench, box, 5/8-inch

Materials/Parts

Nitrogen, technical (item 17, Appendix C)
Packing, plug

Personnel Required

One

LOCATION	ITEM	ACTION	REMARKS
----------	------	--------	---------

CHARGING

- | | | | |
|---|-----------------|-------------------------------------|--|
| 1 | Accumulator (1) | Plug (2) with assembled packing (3) | Using 5/8-inch box wrench, unscrew and take out. |
| 2 | Plug (2) | Packing (3) | a Using pocket knife, take off.
b Get rid of. |

CAUTION

Use only dry nitrogen to charge hydraulic accumulator. Using air or any combustible gas may cause damage to internal parts.

When charging accumulator, be careful not to exceed specified pressure or damage to internal parts may occur.

- | | | | |
|---|---------------------------|-----------------|---|
| 3 | Bracket (4) and clamp (5) | Accumulator (1) | a Using Nuday ND925-0 (-W) accumulator charging kit, John Deere R40617 connector, and John Deere AR47753 hose connected to charging port, charge.
Accumulator is charged when gage on charging kit reads 475 to 525 psi (3275 to 3620 kPa).
b. If overcharged, use Nuday ND925-0 (-W) accumulator charging kit with gage and valve disconnected from technical nitrogen tank to bleed off any excess pressure. |
|---|---------------------------|-----------------|---|

HYDRAULIC ACCUMULATOR CHARGING - CONTINUED

LOCATION	ITEM	ACTION	REMARKS
4 Plug (2)	New packing (3)	Place in position.	c Disconnect Nuday ND925-0 (-W) accumulator charging kit, John Deere R40617 connector, and John Deere AR47753 hose.
5 Accumulator (1)	Plug (2) with assembled packing (3)	Screw in and tighten using 5/8-inch box wrench.	

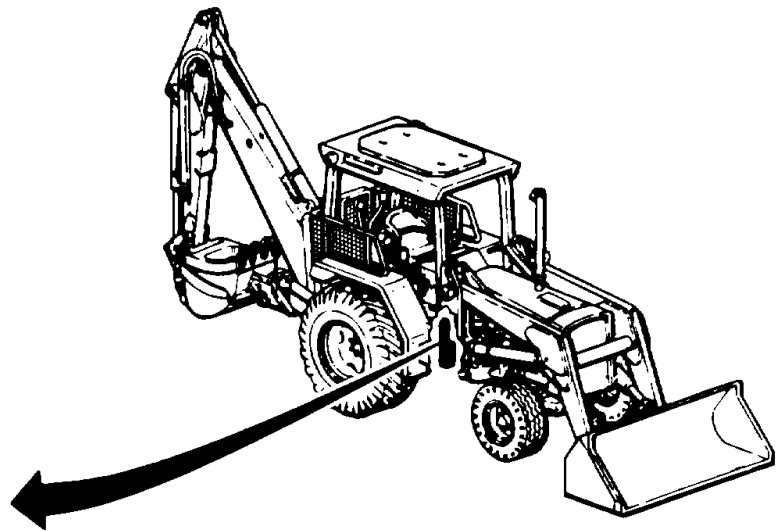
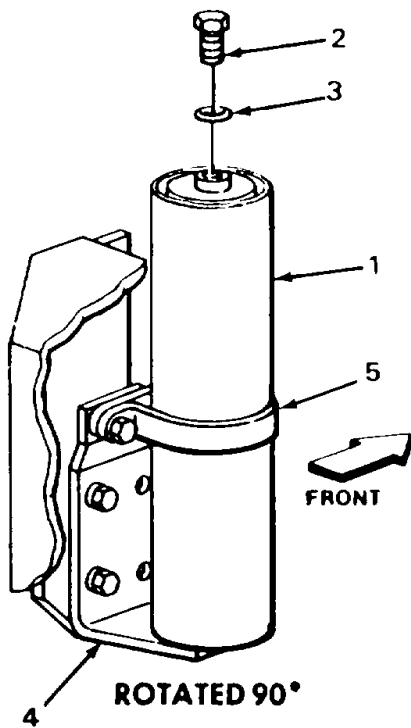

TASK ENDS HERE

TA243305

PUMP STROKE CONTROL VALVE FILTER ELEMENT

This task covers:

- a. Removal (page 2-1196)
 - b. Cleaning (page 2-1197)
 - c. Inspection/Replacement (page 2-1198)
 - d. Installation (page 2-1198)
-

INITIAL SETUP

Tools

- Knife, pocket
- Pan, drain
- Screwdriver, flat-tip, 1/8-inch
- Wrench, box and open-end, combination, 1 1/4 - inch

Materials/Parts

- Filter element
- Packing, filter element (two required)
- Packing, filter plug

Materials/Parts - Continued

- Rags, wiping (item 21, Appendix C)
- Solvent, drycleaning (item 28, Appendix C)

Personnel Required

Two

Equipment Condition

1. Hydraulic system pressure released (page 2-1191)
 2. Right side grille removed (TM 5-2420-222-10)
-

LOCATION	ITEM	ACTION	REMARKS
----------	------	--------	---------

REMOVAL

WARNING

Do not attempt to disconnect hydraulic lines and fittings while engine is running or before hydraulic system pressure has been released. When engine is running, hydraulic system is under pressure. Hydraulic system pressure should be 0 psi (0 kPa) before lines are disconnected. A line or fitting disconnected under pressure will blow off with a lot of force and could cause serious injury to personnel.

Be careful when draining hot fluids. Wear gloves to protect your hands from hot parts and fluids or severe burns could result.

- | | | |
|----------------|-------------------------------------|--|
| 1. Housing (1) | Plug (2) with assembled packing (3) | <ol style="list-style-type: none"> a. Place drain pan underneath to catch draining fluid. b. Using 1 1/4-inch combination box and open-end wrench, unscrew and take out. |
|----------------|-------------------------------------|--|

PUMP STROKE CONTROL VALVE FILTER ELEMENT - CONTINUED

LOCATION	ITEM	ACTION	REMARKS
2.	Filter element (4) and two packings (5)	a. Using 1/8-inch flat-tip screwdriver, take out. b. Get rid of packing (5). c. Plug housing (1) (page 2-137). d. Get rid of drained fluid (page 2-137).	
3. Plug (2)	Packing (3)	a. Using pocket knife, take off. b. Get rid of.	

CLEANING

NOTE

For more information on how to clean parts, go to **General Maintenance Instructions (page 2-137)**.

WARNING

Drycleaning solvent P-D-680 is toxic and flammable. Wear protective goggles and gloves and use only in a well ventilated area. Avoid contact with skin, eyes, and clothes and don't breathe vapors. Do not use near open flame or excessive heat. The flashpoint is 100°F to 138°F (38° to 59°C). If you become dizzy while using cleaning solvent, get fresh air immediately and get medical aid. If contact with eyes is made, wash your eyes with water and get medical aid immediately.

- | | | |
|----|------------------------------------|---|
| 4. | Plug (2) and
filter element (4) | a. Clean in drycleaning solvent.
b. Using clean, dry rags, wipe dry. |
|----|------------------------------------|---|

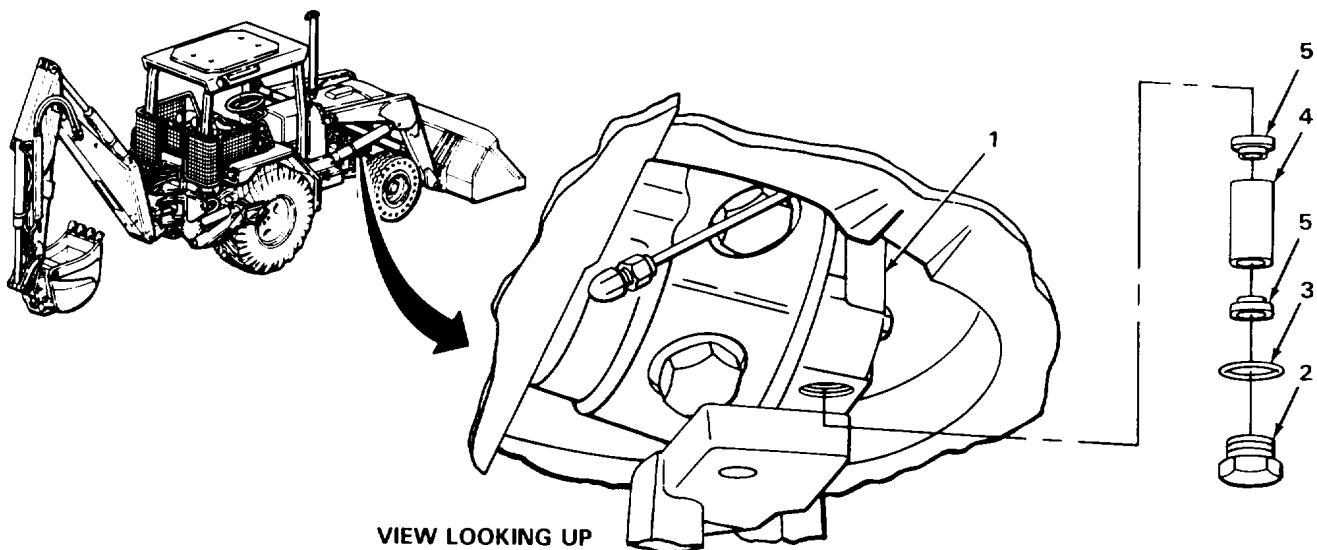

TA243306

PUMP STROKE CONTROL VALVE FILTER ELEMENT - CONTINUED

LOCATION	ITEM	ACTION	REMARKS
INSPECTION/REPLACEMENT			
NOTE			
For more information on how to inspect parts, go to General Maintenance Instructions (page 2-137).			
Replace defective parts as needed.			
5.	Plug (1)	a. Look for cracks and breaks. b. Look for damaged threads.	
6.	Filter element (2) dents.	a. Look for cracks, breaks, bends, and b. Look for plugged wire mesh which cannot be cleaned. c. Look for enlarged holes in wire mesh.	
INSTALLATION			
7.	Plug (1)	New packing (3)	Place in position.
8.	Housing (4)	Filter element (2) and two new packings (5)	a. Unplug housing (4). b. Place in position.
9.		Plug (1) with assembled packing (3)	Screw in and tighten using 1 1/4-inch combination box and open-end wrench.
10.	Loader backhoe	Transmission	Check fluid level and add proper amount and grade (TM 5-2420-222-10).
11.		Engine	Start and run at high idle (TM 5-2420-222-10).
12.	Housing (4)	Plug (1)	a. Check for leaks. b. If leaking, tighten using 1 1/4-inch combination box and open-end wrench. c. If leaking does not stop, shut down engine (TM 5-2420-222-10) and replace defective packing or plug as outlined in this task. d. If found leaking, repeat steps 10 thru 12.
13.	Loader backhoe	Engine	If still running, shut down (TM 5-2420-222-10).

PUMP STROKE CONTROL VALVE FILTER ELEMENT - CONTINUED

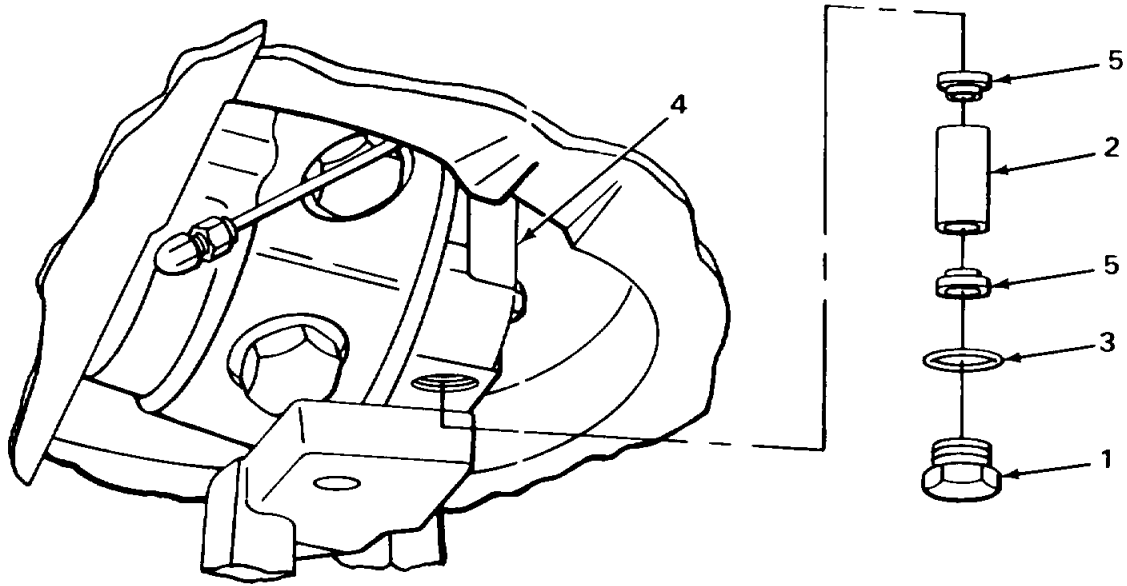

VIEW FROM UNDERNEATH

NOTE

FOLLOW-ON MAINTENANCE: Install right side grille (TM 5-2420-222-10).

TASK ENDS HERE

TA 243307

PRESSURE CONTROL VALVE

This task covers:

- | | |
|---|-------------------------------|
| a. Removal (page 2-1200) | e. Repair (page 2-1206) |
| b. Disassembly (page 2-1202) | f. Assembly (page 2-1206) |
| c. Cleaning (page 2-1204) | g. Installation (page 2-1208) |
| d. Inspection/Replacement (page 2-1205) | h. Adjustment (page 2-1210) |
-

INITIAL SETUP

Tools

- Caliper, micrometer, outside, 0 to 1-inch
- Caps, vise jaw (pair)
- Compressor, reciprocating air
- Extension, 3/8-inch drive, 5-inch
- Fitting kit, tube and pipe
- Gage, multi-range, pressure
- Gun, air blow
- Handle, ratchet, 3/8-inch drive
- Hose, air compressor
- Knife, pocket
- Pan, drain
- Pliers, long roundnose
- Press, arbor
- Remover and installer, 0.250-inch outside diameter
- Socket, 3/8-inch drive, 1/2-inch
- Socket, 3/8-inch drive, 9/16-inch
- Tester, spring, 4 to 400-pound capacity
- Thread set, pipe
- Vise, machinist's
- Universal-joint, 3/8-inch drive
- Wrench, open-end, 9/16-inch
- Wrench, open-end, 7/8-inch
- Wrench, open-end, 1-inch
- Wrench, open-end, 1 1/16-inch

Tools - Continued

- Wrench, open-end, 1 1/4-inch (two required)
- Wrench, open-end, 1 3/8-inch
- Wrench, torque, 1/2-inch drive, 0 to 150 foot-pound capacity

Materials/Parts

- Lockwasher, valve screw (three required)
- Packing, adapter union-to-valve
- Packing, connector-to-valve
- Packing, elbow-to-valve
- Packing, plug-to-pump
- Packing, plug-to-valve
- Packing, plug-to-valve
- Packing, valve-to-transmission case
- Packing, valve-to-transmission case
- Solvent, drycleaning (item 28, Appendix C)
- Tags, marking (item 30, Appendix C)

Personnel Required

Two

Equipment Condition

Right side grille removed
(TM 5-2420-222-10)

LOCATION	ITEM	ACTION REMARKS
----------	------	-------------------

REMOVAL

- | | | |
|-------------------|-----------------------------------|-----------------------|
| 1. Loader backhoe | Hydraulic oil filter relief valve | Remove (page 2-1217). |
|-------------------|-----------------------------------|-----------------------|

PRESSURE CONTROL VALVE - CONTINUED

LOCATION	ITEM	ACTION REMARKS
2.	Transmission oil filter	Remove (page 2-836).
3. Elbow (1)	Line (2)	a. Place drain pan underneath to catch draining fluid. b. Using 1-inch open-end wrench, unscrew and take off. c. Cap (page 2-137). d. Tag (page 2-137).
4. Valve assembly (3) and elbow (1)	Nut (4)	Using 1 1/16 and 1 1/4-inch open-end wrenches, loosen.
5. Valve assembly (3)	Elbow (1) with assembled parts	a. Note relative position for proper placement during installation. b. Using 1 1/16-inch open-end wrench, unscrew and take out.
6. Connector (5)	Line (6)	a. Place drain pan underneath to catch draining fluid. b. Using 1 3/8-inch open-end wrench, unscrew and take off. c. Cap (page 2-137). d. Tag (page 2-137).

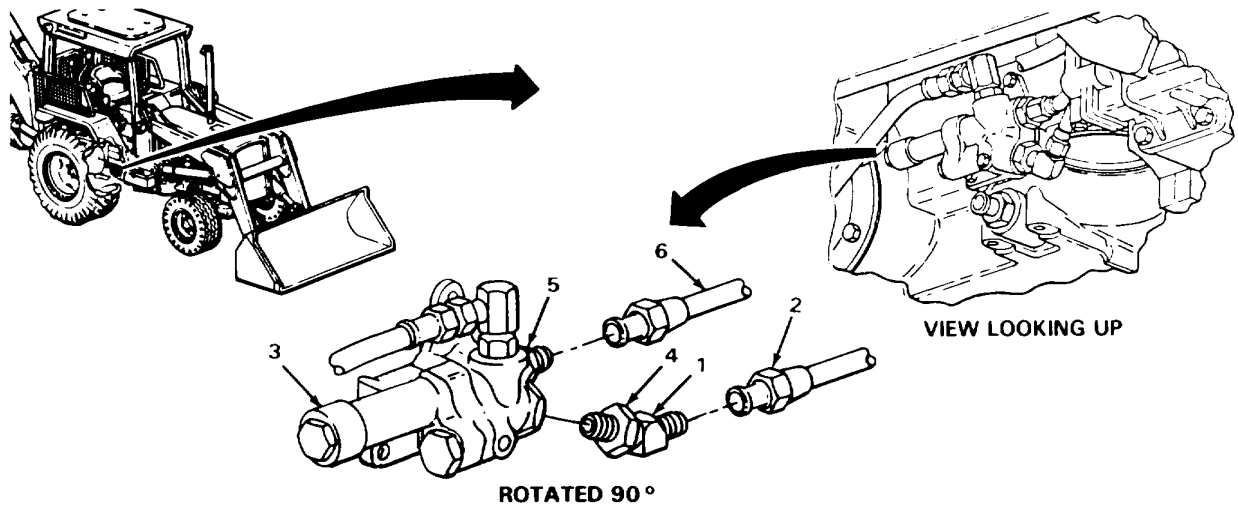

TA243308

PRESSURE CONTROL VALVE - CONTINUED

LOCATION	ITEM	ACTION	REMARKS
REMOVAL - CONTINUED			
NOTE			
Pressure control valve mounting screws are three different lengths. Note position of screws for proper placement during installation.			
7.	Valve assembly (1) and transmission case (2)	Three screws (3, 4, and 5) and three lockwashers (6)	<ul style="list-style-type: none"> a. Place drain pan underneath to catch draining fluid. b. Using 9/16-inch, 3/8-inch drive socket, 5-inch extension, universal joint, ratchet handle, and 9/16-inch open end wrench, unscrew and take out. c. Get rid of lockwashers (6).
8.	Transmission case (2)	Valve assembly (1) with assembled parts	<ul style="list-style-type: none"> a. Take off. b. Allow to drain in drain pan.
9.	Valve assembly (1)	Two packings (7 and 8)	<ul style="list-style-type: none"> a. Using pocket knife, take off. b. Get rid of.
10.	Union adapter (9)	Hose (10)	<ul style="list-style-type: none"> a. Position over drain pan to catch draining fluid. b. Using 1 1/16-inch and 1 1/4-inch open-end wrenches, unscrew and take out. c. Cap (page 2-137). d. Tag (page 2-137). e. Get rid of drained fluid (page 2-137).
11.	Elbow (11)	Packing (12)	<ul style="list-style-type: none"> a. Using pocket knife, take off. b. Get rid of.
DISASSEMBLY			
12.	Pressure housing (13) and union adapter (9)	Nut (14)	<ul style="list-style-type: none"> a. Place housing (13) in machinist's vise with vise jaw caps. b. Using two 1 1/4-inch open-end wrenches, loosen.
13.	Pressure housing (13)	Union adapter (9) with assembled parts	<ul style="list-style-type: none"> a. Note relative position for proper placement during assembly. b. Using 1 1/4-inch open-end wrench, unscrew and take out.
14.	Union adapter (9)	Packing (15)	<ul style="list-style-type: none"> a. Using pocket knife, take off. b. Get rid of.

PRESSURE CONTROL VALVE - CONTINUED

LOCATION	ITEM	ACTION	REMARKS
15. Pressure housing (13) and valve (16)	Connector (17) with assembled packing (18)	Using 1 3/8-inch open-end wrench, unscrew and take out.	
16. Connector (17)	Packing (18)	a. Using pocket knife, take off. b. Get rid of.	
17. Pressure housing (13) and valve (16)	Pin (19)	a. Depress valve (16) by hand to relieve spring tension. b. Using long roundnose pliers, take out.	

NOTE

Loader backhoes with Serial Numbers 235786 thru 235999 use one or more washers between spring and orifice. Loader backhoes with Serial Numbers 319995 thru 342573 do not use washers in this position.

18. Pressure housing (13)	Valve (16), washers (20), if present, and spring (21)	a. Take out. b. If found, note quantity of washers (20) so same number can be used during assembly.
---------------------------	---	--

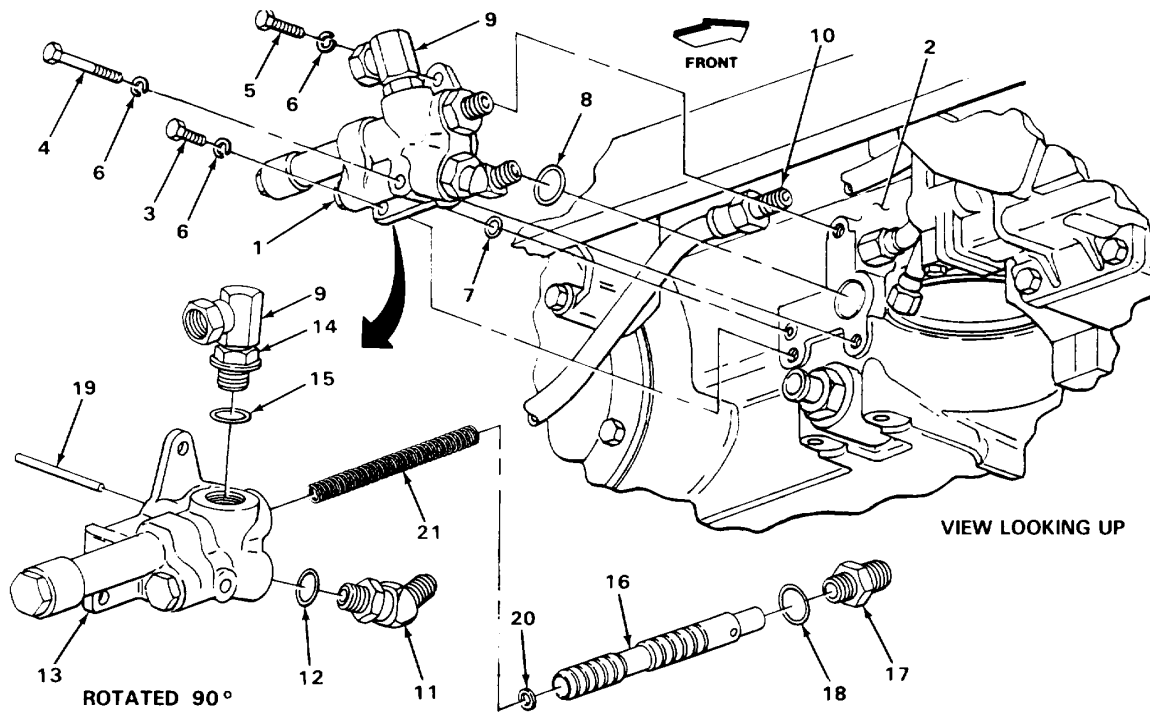

TA243309

PRESSURE CONTROL VALVE - CONTINUED

LOCATION	ITEM	ACTION REMARKS
DISASSEMBLY - CONTINUED		
19. Pressure housing (1)	Plug (2) with assembled parts	Using 1-inch open-end wrench, unscrew and take out.
20. Plug (2)	Packing (3)	a. Using pocket knife, take off. b. Get rid of.
21.	Washers (4)	a. On loader backhoes with Serial Numbers 319995 thru 342573 only, take off. b. Note number of washers used for proper spacing of plug (2) during assembly.
22. Pressure housing (1)	Plug (5) with assembled packing (6)	a. Using 7/8-inch open-end wrench, unscrew and take out. b. Take housing (1) out of machinist's vise.
23. Plug (5)	Packing (6)	a. Using pocket knife, take off. b. Get rid of.

CAUTION

Do not remove orifice from pressure control valve unless inspection shows need for replacement. Removal will damage parts.

24. Valve (7)	Orifice (8)	Using 0.250-inch remover and installer and arbor press, press out.
---------------	-------------	--

CLEANING

NOTE

For more information on how to clean parts, go to General Maintenance Instructions (page 2-137).

WARNING

Drycleaning solvent P-D-680 is toxic and flammable. Wear protective goggles and gloves and use only in a well ventilated area. Avoid contact with skin, eyes, and clothes and don't breathe vapors. Do not use near open flame or excessive heat. The flashpoint is 100°F to 138°F (38° to 59°C). If you become dizzy while using cleaning solvent, get fresh air immediately and get medical aid. If contact with eyes is made, wash your eyes with water and get medical aid immediately.

PRESSURE CONTROL VALVE - CONTINUED

LOCATION	ITEM	ACTION	REMARKS
CLEANING - CONTINUED			
<u>WARNING</u>			
<p>Compressed air used for blowing away chips, dirt, etc., must leave nozzle at less than 30 psi (207 kPa) to prevent personal injury. Be certain that nozzle is rated to provide a maximum of 30 psi (207 kPa). Be sure to wear safety goggles or lenses when using compressed air. Compressed air and particles moved by compressed air can cause damage to your eyes.</p>			
25.	All parts	a. Clean in drycleaning solvent. b. Using reciprocating air compressor, air compressor hose, and air blow gun, blow dry.	

INSPECTION/REPLACEMENT

NOTE

For more information on how to inspect parts, go to General Maintenance Instructions (page 2-137).

Replace defective parts which cannot be repaired.

- | | | |
|-----|-----------|---|
| 26. | Valve (7) | <ul style="list-style-type: none"> a. Look for cracks, breaks, grooves, pits, and deep scratches. b. Using 0 to 1-inch outside micrometer caliper, measure outside diameter at front and rear. <p style="margin-left: 20px;">Outside diameter at front should be 0.7497 to 0.7503 inch (19.0424 to 19.0576 mm). Outside diameter at rear should be 0.7257 to 0.7263 inch (18.4328 to 18.4480 mm).</p> |
|-----|-----------|---|

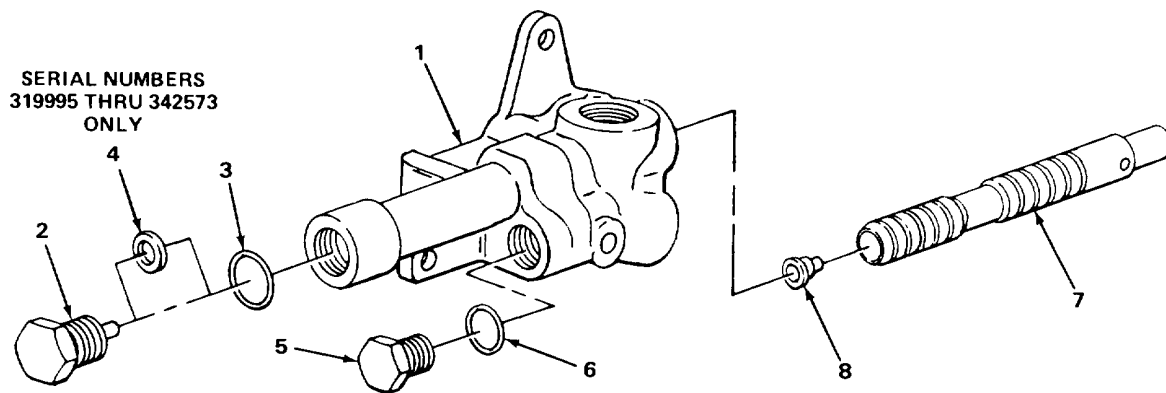

TA243310

PRESSURE CONTROL VALVE - CONTINUED

LOCATION	ITEM	ACTION	REMARKS
INSPECTION/REPLACEMENT - CONTINUED			
27.	Spring (1)	a. Look for cracks, breaks, and abnormal bends. b. Using 4 to 400-pound capacity spring tester, measure free length. Free length should be approximately 4.625 inches (117.475 mm). c. Using 4 to 400-pound capacity spring tester and 0 to 150 foot-pound capacity, 1/2-inch drive torque wrench, apply 50 foot-pounds (68 N•m) torque and measure compressed length. Compressed length should be approximately 3.5 inches (88.9 mm).	
28.	Pressure housing (2)	a. Look for cracks and breaks. b. Look for grooves, pits, and deep scratches in valve bore.	
29.	All other parts	Look for cracks and breaks.	
30.	All threaded parts	Look for damaged threads.	
REPAIR			
31.	Pressure housing (2)	If threads are damaged, using pipe thread set, restore threads.	

ASSEMBLY

CAUTION

Be careful not to damage orifice during assembly. Damaged orifice may cause pressure control valve to operate improperly.

32. Valve (3)	Orifice (4)	If removed, using 0.250-inch outside diameter remover and installer and arbor press, press in.	
33. Plug (5)	New packing (6)	Place in position.	
34. Pressure housing (2)	Plug (5) with assembled packing (6)	a. Place housing (2) in machinist's vise with vise jaw caps. b. Screw in and tighten using 7/8-inch open-end wrench.	

PRESSURE CONTROL VALVE - CONTINUED

LOCATION	ITEM	ACTION	REMARKS
35. Plug (7)	Washer (8)		On loader backhoes with Serial Numbers 319995 thru 342573 only, place same number as removed during disassembly in position.
36.	New packing (9)		Place in position.
37. Pressure housing (2)	Plug (7) with assembled parts		Screw in and tighten using 1-inch open-end wrench.
38. Connector (10)	New packing (11)		Place in position.
39. Valve (3)	Washers (12)		On loader backhoes with Serial Numbers 235786 thru 235999 only, place same number as removed during disassembly in position.
40.	Spring (1)		Place in position.
41. Pressure housing (2)	Valve (3) with assembled parts		Place in position.
42. Pressure housing (2) and valve (3)	Pin (13)	a. Using long roundnose pliers, depress valve (3) until aligned with hole in housing (2). b. Place in position.	
43. Pressure housing (2) and valve (3)	Connector (10) with assembled packing (11)		Screw in and tighten using 1 3/8-inch open-end wrench.

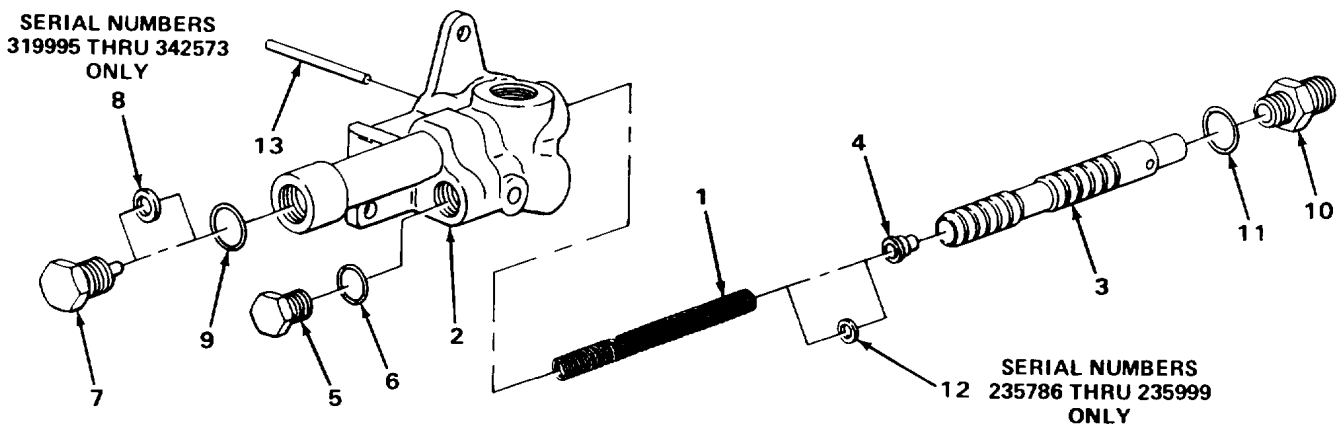

TA243311

PRESSURE CONTROL VALVE - CONTINUED

LOCATION	ITEM	ACTION	REMARKS
ASSEMBLY - CONTINUED			
44.	Union adapter (1)	Nut (2)	Screw on all the way.
45.		New packing (3)	Place in position.
46.	Pressure housing (4)	Union adapter (1) with assembled parts	Screw in and tighten to position noted during disassembly using 1 1/4-inch open-end wrench.
47.	Union adapter (1) and pressure housing (4)	Nut (2)	<ol style="list-style-type: none"> Tighten until seated against housing (4) using two 1 1/4-inch open-end wrenches. Take housing (4) out of machinist's vise with vise jaw caps.
INSTALLATION			
48.	Elbow (5)	Nut (6)	Screw in all the way.
49.		New packing (7)	Place in position.
50.	Union adapter (1)	Hose (8)	<ol style="list-style-type: none"> Uncap. Take off tag. Screw in and tighten using 1 1/16-inch and 1 1/4-inch open-end wrenches.
51.	Valve assembly (9)	Two new packings (10 and 11)	Place in position.
52.	Transmission case (12)	Valve assembly (9) with attached parts	Place in position.
NOTE			
Pressure control valve mounting screws are three different lengths. Install each screw in position as noted during removal.			
53.	Transmission case (12) and valve assembly (9)	Three screws (13, 14, and 15) and three new lockwashers (16)	Screw in and tighten using 9/16-inch, 3/8-inch drive socket, 5-inch extension, universal-joint, ratchet handle, and 9/16-inch open-end wrench.

PRESSURE CONTROL VALVE - CONTINUED

LOCATION	ITEM	ACTION	REMARKS
54. Connector(17)	Line (18)	a. Uncap. b. Takeoff tag. c. Screw in and tighten using 1 3/8-inch open-end wrench.	
55. Valve assembly (9)	Elbow (5) with assembled parts		Screw in and tighten to position noted during removal using 1 1/16-inch open-end wrench.
56. Valve assembly (9) and elbow (5)	Nut (6)		Tighten until seated against valve assembly (9) using 1 1/16-inch and 1 1/4-inch open-end wrenches.
57. Elbow (5)	Line (19)	a. Uncap. b. Take off tag. c. Screw in and tighten using 1-inch open-end wrench.	
58. Loader backhoe	Transmission oil filter		Install (page 2-836).

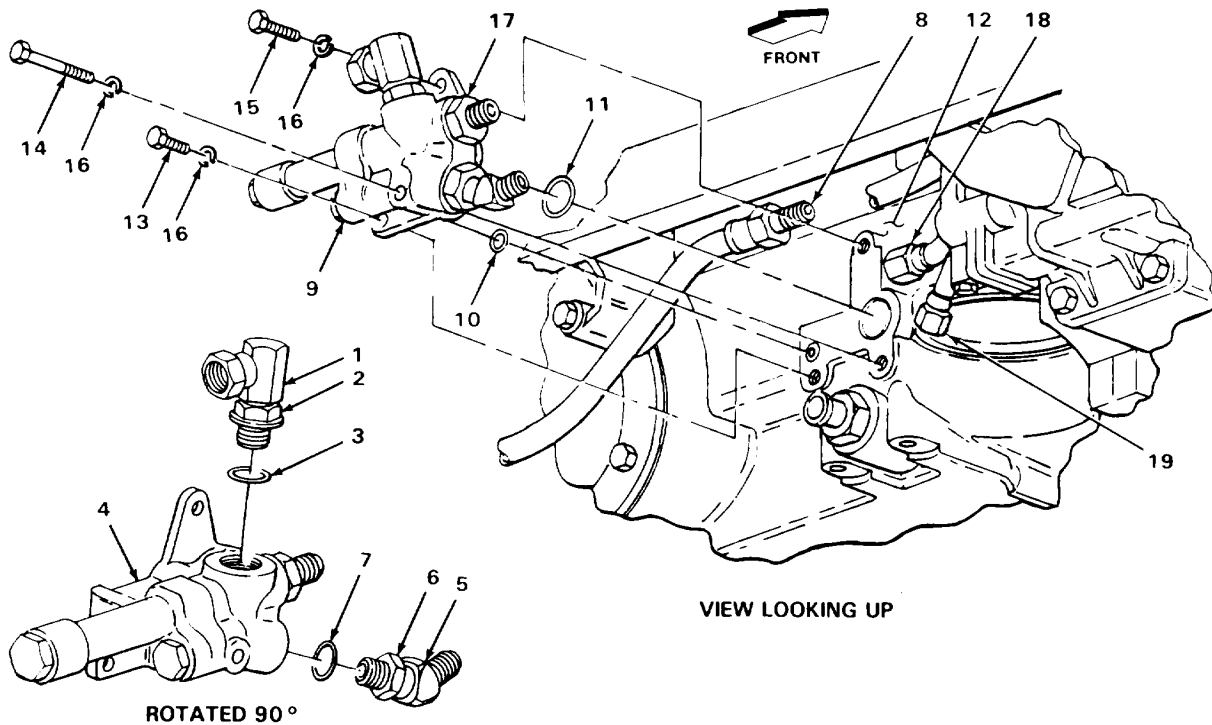

TA243312

PRESSURE CONTROL VALVE - CONTINUED

LOCATION	ITEM	ACTION	REMARKS
INSTALLATION - CONTINUED			
59.	Loader backhoe	Hydraulic oil filter relief valve	Install (page 2-1217).
60.		Transmission	Check fluid level and add proper amount and grade (TM 5-2420-222-10). Do not shut down engine at this time.
61.		Engine	Run at high idle (TM 5-2420-222-10).
62.		Pressure control valve	<ol style="list-style-type: none"> Raise and lower loader bucket (TM 5-2420-222-10) and check for leaks. If leaking at any connection, tighten using 7/8-inch, 1 3/8-inch, 1 1/4-inch, or two 1 1/4-inch open-end wrenches or 1 1/16-inch and 1 1/4-inch open-end wrenches. If leaking does not stop, shut down engine (TM 5-2420-222-10) and replace leaking connection packing or fitting or valve component as outlined in this task. If found leaking, repeat steps 60 thru 62).
63.		Engine	If still running, shut down (TM 5-2420-222-10).

ADJUSTMENT

WARNING

Do not attempt to disconnect hydraulic lines and fittings while engine is running or before hydraulic system pressure has been released. When engine is running, hydraulic system is under pressure. Hydraulic system pressure should be 0 psi (0 kPa) before lines are disconnected. A line or fitting disconnected under pressure will blow off with a lot of force and could cause serious injury to personnel.

64.		Hydraulic system	Release pressure (page 2-1191).
-----	--	------------------	---------------------------------

WARNING

Be careful when draining hot fluids. Wear gloves to protect your hands from hot parts and fluids or severe burns could result.

PRESSURE CONTROL VALVE - CONTINUED

LOCATION	ITEM	ACTION	REMARKS
65. Hydraulic pump (1)	Plug (2) with assembled packing (3)	a. Place drain pan under pump (1) to catch draining fluid. b. Using 1/2-inch, 3/8-inch drive socket, 5-inch extension, and ratchet handle, unscrew and take out.	
66. Plug (2)	Packing (3)	a. Using pocket knife, take off. b. Get rid of.	
67. Front support (4)	Hydraulic pump (1)	Using tube and pipe fitting kit fittings, connect multi-range pressure gage.	

WARNING

Be careful of moving parts when working near engine while it is running. Moving parts could catch on tools, clothing, or extremities causing serious injury.

68. Loader backhoe	Engine	Have assistant start and run at 1250 rpm (TM 5-2420-222-10).
--------------------	--------	--

WARNING

Keep clear of hydraulic components when raised and not supported. Sudden loss of hydraulic pressure could cause components to drop without warning.

69.	Loader bucket	While assistant raises (TM 5-2420-222-10), note multi-range pressure reading. Reading should be 1700 to 1800 psi (11721 to 12411 kPa), pressure control valve setting.
70.	Engine	Have assistant shut down (TM 5-2420-222-10).

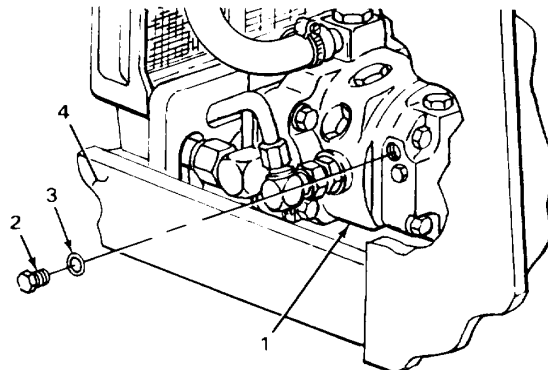
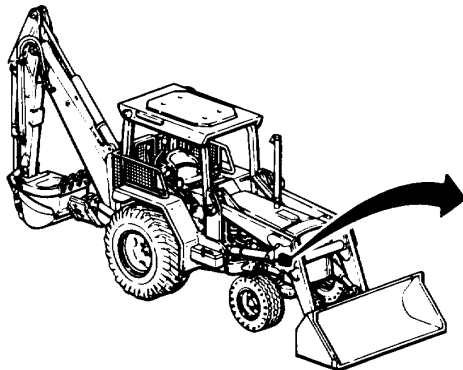

TA243313

PRESSURE CONTROL VALVE - CONTINUED

LOCATION	ITEM	ACTION	REMARKS
----------	------	--------	---------

ADJUSTMENT - CONTINUED

NOTE

If pressure control valve setting measured in step 69 is correct, skip steps 71 thru 81.

WARNING

Do not attempt to disconnect hydraulic lines and fittings while engine is running or before hydraulic system pressure has been released. When engine is running, hydraulic system is under pressure. Hydraulic system pressure should be 0 psi (0 kPa) before lines are disconnected. A line or fitting disconnected under pressure will blow off with a lot of force and could cause serious injury to personnel.

71.	Hydraulic system	Release pressure (page 2-1191).
-----	------------------	---------------------------------

WARNING

Be careful when draining hot fluids. Wear gloves to protect your hands from hot parts and fluids or severe burns could result.

72.	Pressure housing (1) Plug (2) with assembled parts	<ul style="list-style-type: none"> a. Place drain pan underneath to catch draining fluid. b. Using 1-inch open-end wrench, unscrew and take out.
-----	---	--

NOTE

Steps 73 thru 77 only apply to loader backhoes with Serial Numbers 235786 thru 235999.

There may be one or several washers used between spring and orifice.

73.	Pressure housing (1), valve (3), and washers (4)	Spring (5)	Take out.
74.	Valve (3) and orifice (6)	Washers (4)	<ul style="list-style-type: none"> a. If pressure reading noted in step 69 was more than 1800 psi (12,411 kPa), decrease number. b. If pressure reading noted in step 69 was less than 1700 psi (11,721 kPa), increase number.

PRESSURE CONTROL VALVE - CONTINUED

LOCATION	ITEM	ACTION	REMARKS
75. Plug (2)	Packing (7)	a. If not replaced during assembly, using pocket knife, take off. b. Get rid of. c. Place new one in position.	
76. Pressure housing (1), valve (3), and washers (4)	Spring (5)	Place in position.	
77. Pressure housing (1)	Plug (2) with assembled parts	a. Screw in and tighten using 1-inch open-end wrench. b. Repeat steps 68 thru 77.	

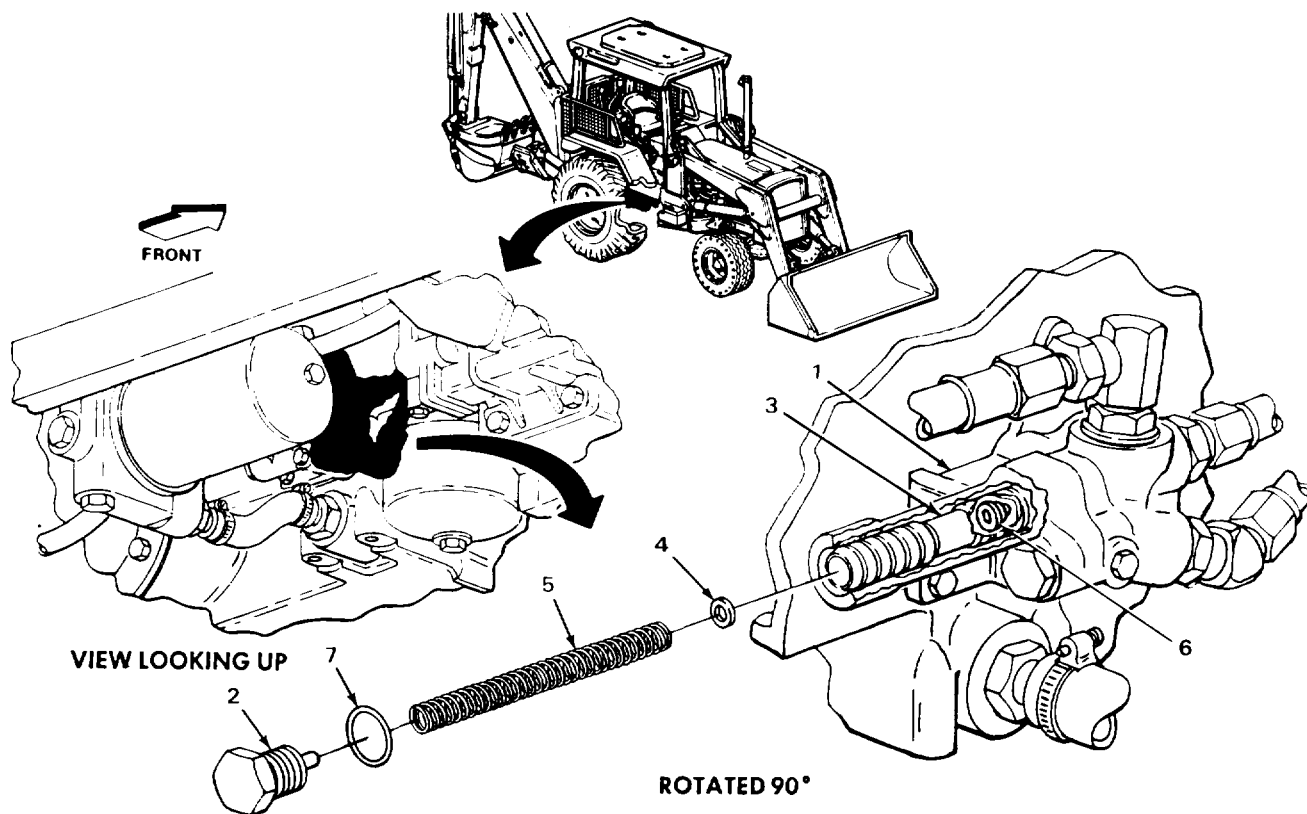

TA243314

PRESSURE CONTROL VALVE - CONTINUED

LOCATION	ITEM	ACTION	REMARKS
----------	------	--------	---------

ADJUSTMENT - CONTINUED

NOTE

Steps 78 thru 80 only apply to loader backhoes with Serial Numbers 319995 thru 342573.

78.	Plug (1)	Packing (2)	<ul style="list-style-type: none"> a. If not replaced during assembly, using pocket knife, take off. b. Get rid of. c. Place new one in position.
-----	----------	-------------	--

NOTE

There may be one or several washers in plug.

79.		Washers (3)	<ul style="list-style-type: none"> a. If pressure reading noted in step 69 was more than 1800 psi (12,411 kPa), decrease number. b. If pressure reading noted in step 69 was less than 1700 psi (11,721 kPa), increase number.
80.	Pressure housing (4) and spring (5)	Plug (1) with assembled parts	<ul style="list-style-type: none"> a. Screw in and tighten using 1-inch open-end wrench. b. Repeat steps 68 thru 80.

WARNING

Do not attempt to disconnect hydraulic lines and fittings while engine is running or before hydraulic system pressure has been released. When engine is running, hydraulic system is under pressure. Hydraulic system pressure should be 0 psi (0 kPa) before lines are disconnected. A line or fitting disconnected under pressure will blow off with a lot of force and could cause serious injury to personnel.

81.	Loader backhoe	Hydraulic system	Release pressure (page 2-1191).
-----	----------------	------------------	---------------------------------

WARNING

Be careful when draining hot fluids. Wear gloves to protect your hands from hot parts and fluids or severe burns could result.

82.	Front support (6)	Hydraulic pump (7)	<ul style="list-style-type: none"> a. Place drain pan underneath to catch draining fluid. b. Disconnect multi-range pressure gage and tube and pipe fitting kit fittings.
-----	-------------------	--------------------	---

PRESSURE CONTROL VALVE - CONTINUED

LOCATION	ITEM	ACTION	REMARKS
83. Plug (8)	New packing (9)	Place in position.	
84. Hydraulic pump (7)	Plug (8) with assembled packing (9)	a. Screw in and tighten using 1/2-inch, 3/8-inch drive socket, 5-inch extension, and ratchet handle. b. Get rid of drained fluid (page 2-137).	

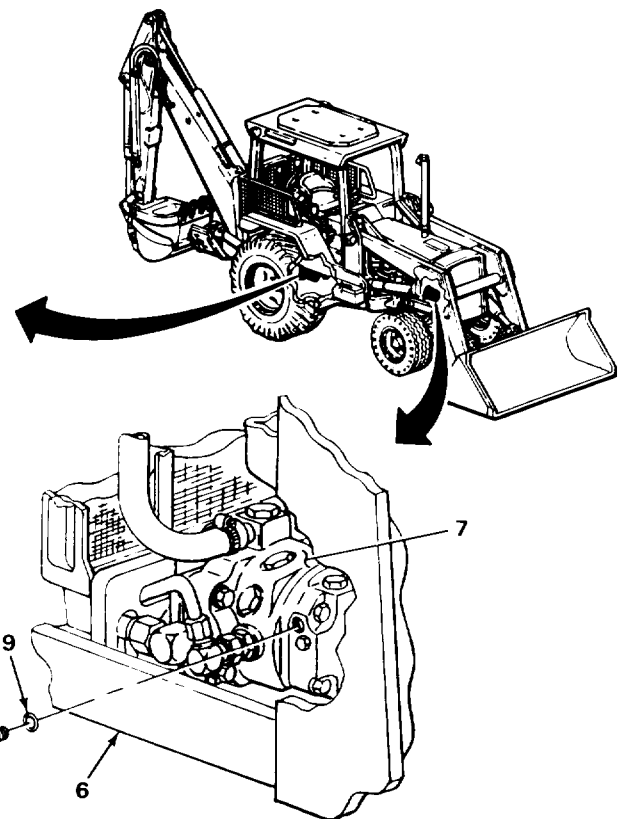
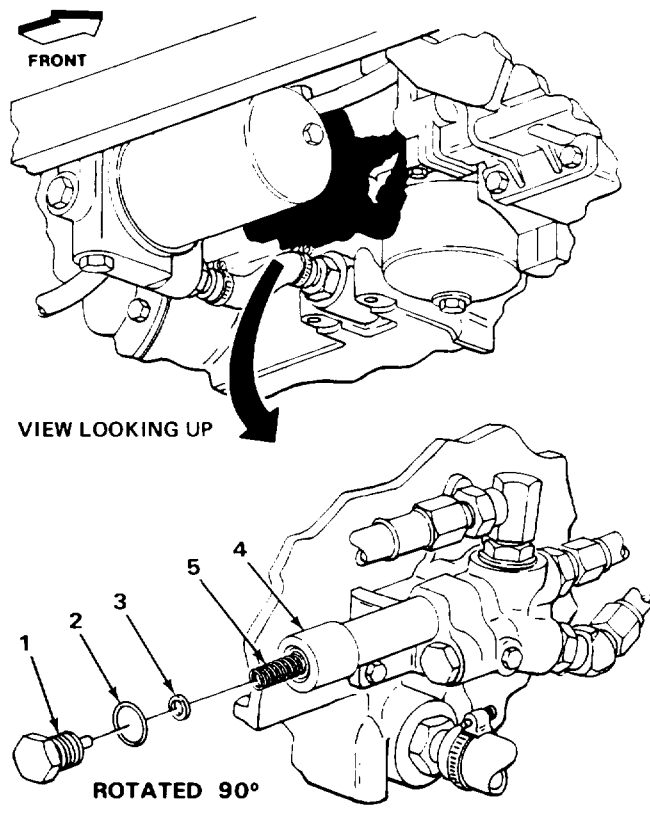

PRESSURE CONTROL VALVE - CONTINUED

LOCATION	ITEM	ACTION	REMARKS
ADJUSTMENT - CONTINUED			
85.	Loader backhoe	Transmission	Check fluid level and add proper amount and grade (TM 5-2420-222-10). Do not shut down engine at this time.
86.		Engine	Run at high idle (TM 5-2420-222-10).
WARNING			
Be careful of moving parts when working near engine while it is running. Moving parts could catch on tools, clothing, or extremities causing serious injury.			
87.	Pressure control valve and hydraulic pump		<ol style="list-style-type: none"> a. Raise and lower loader bucket (TM 5-2420-222-10) and check for leaks. b. If leaking at any connection, tighten using 1/2-inch, 3/8-inch drive socket, 5-inch extension, and ratchet handle or 1-inch open-end wrench. c. If leaking does not stop, shut down engine (TM 5-2420-222-10) and replace leaking connection packing or plug as outlined in this task. d. If found leaking, repeat steps 85 thru 87.
88.		Engine	If still running, shut down (TM 5-2420-222-10).

NOTE**FOLLOW-ON MAINTENANCE: Install right side grille (TM 5-2420-222-10).**

TASK ENDS HERE

HYDRAULIC OIL FILTER RELIEF VALVE

This task covers:

- | | |
|---|-------------------------------|
| a. Removal (page 2-1218) | e. Repair (page 2-1224) |
| b. Disassembly (page 2-1220) | f. Assembly (page 2-1224) |
| c. Cleaning (page 2-1222) | g. Installation (page 2-1226) |
| d. Inspection/Replacement (page 2-1222) | |
-

INITIAL SETUP:**Tools**

Caps, vise jaw (pair)
 Compressor, reciprocating air
 Gun, air blow
 Handle, ratchet, 3/8-inch drive
 Hose, air compressor
 Knife, pocket
 Pan, drain
 Pliers, long roundnose
 Retrieving tool, magnetic
 Screwdriver, flat-tip, 1/4-inch
 Screwdriver, flat-tip, 3/8-inch
 Socket, 3/8-inch drive, 9/16-inch
 Tester, spring, 4 to 400-pound capacity
 Thread set, pipe
 Vise, machinist's
 Wrench, open-end, 1-inch
 Wrench, open-end, 1 1/8-inch
 Wrench, open-end, 1 1/4-inch (two required)
 Wrench, open-end, 1 7/8-inch (two required)
 Wrench, torque, 1/2-inch drive, 0 to 150 foot-pound capacity

Materials/Parts

Lockwasher, valve screw (two required)
 Packing, adapter union-to-valve
 Packing, connector-to-valve
 Packing, elbow-to-valve
 Packing, housing
 Packing, plug-to-valve
 Packing, plug-to-valve
 Ring, spacer, connector-to-valve
 Solvent, drycleaning (item 28, Appendix C)
 Tags, marking (item 30, Appendix C)

Personnel Required

Two

Equipment Condition

1. Hydraulic pressure released (page 2-1191)
2. Hydraulic oil filter removed (page 2-1698)
3. Transmission drained (page 2-811)

2-1217

HYDRAULIC OIL FILTER RELIEF VALVE - CONTINUED

LOCATION	ITEM	ACTION	REMARKS
REMOVAL			
WARNING			
<p>Do not attempt to disconnect hydraulic lines and fittings while engine is running or before hydraulic system pressure has been released. When engine is running, hydraulic system is under pressure. Hydraulic system pressure should be 0 psi (0 kPa) before lines are disconnected. A line or fitting disconnected under pressure will blow off with a lot of force and could cause serious injury to personnel.</p>			
<p>Be careful when draining hot fluids. Wear gloves to protect your hands from hot parts and fluids or severe burns could result.</p>			
1. Hose (1)	Two clamps (2 and 3)	a. Place drain pan underneath to catch draining fluid. b. Using 1/4-inch flat-tip screwdriver, unscrew and take off.	
2. Two connectors (4 and 5)	Hose (1)	a. Using 1/4-inch and 3/8-inch flat-tip screwdriver, pry off. b. Tag (page 2-137). c. Cap connector (5) (page 2-137).	
3. Hose (6)	Clamp (7)	a. Place drain pan underneath to catch draining fluid. b. Using 1/4-inch flat-tip screwdriver, loosen and slide back.	
4. Union adapter (8)	Hose (9)	a. Place drain pan underneath to catch draining fluid. b. Using 1 1/8-inch and 1 1/4-inch open-end wrenches,, unscrew and take out. c. Tag (page 2-137). d. Cap (page 2-137).	
5. Hose (10)	Clamp (11)	a. Place drain pan underneath to catch draining fluid. b. Using 1/4-inch flat-tip screwdriver, loosen.	
6. Main frame (12) and valve (13)	Two screws (14), washers (15), and lockwashers (16)	a. Using 9/16-inch, 3/8-inch drive socket and ratchet handle, unscrew and take out. b. Get rid of lockwashers (16).	

HYDRAULIC OIL FILTER RELIEF VALVE - CONTINUED

LOCATION	ITEM	ACTION	REMARKS
7. Main frame (12) and two hoses (6 and 10)	Valve (13) with assembled parts	a. While supporting, using 3/8-inch flat-tip screwdriver, pry loose from two hoses (9 and 10) and take out. b. Allow fluid to drain into drain pan. c. Cap hoses (6 and 10) (page 2-137). d. Get rid of drained fluid (page 2-137).	

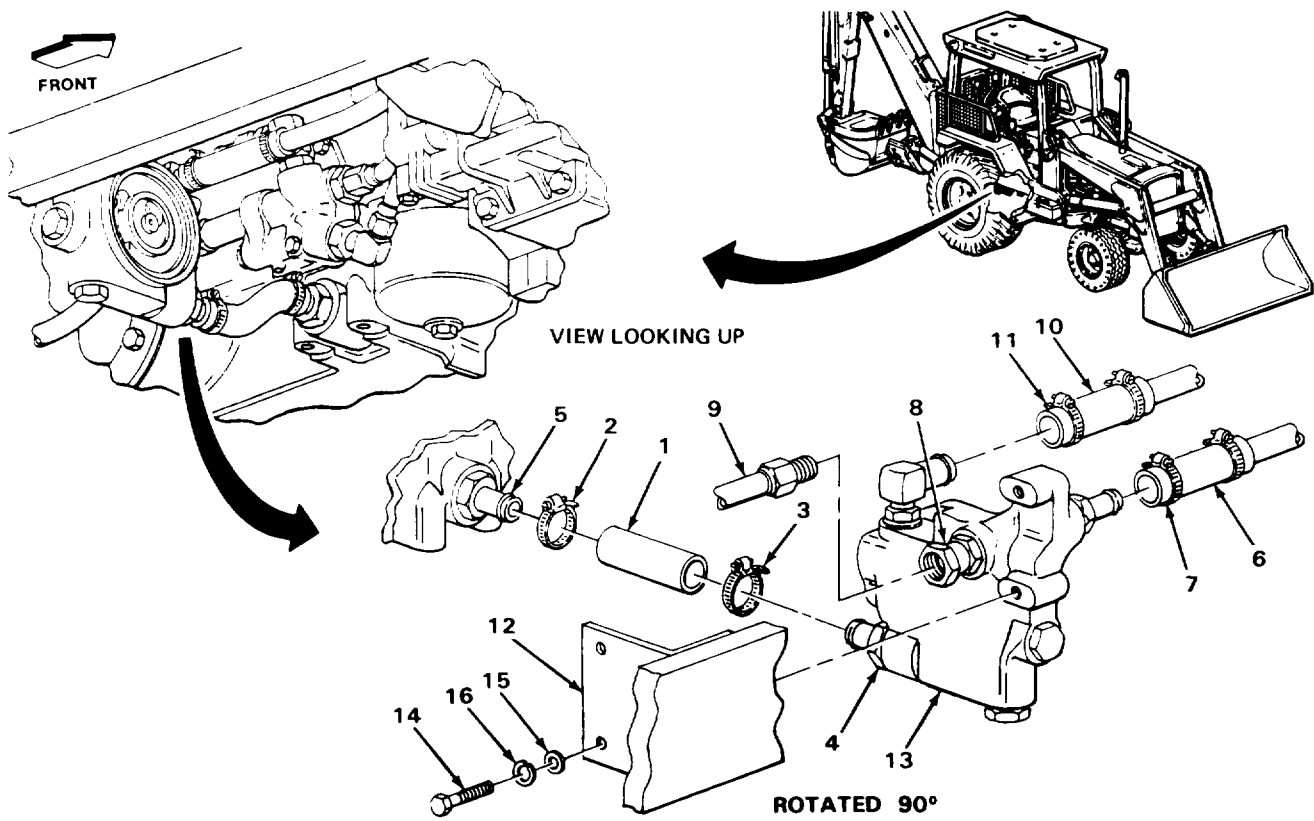

TA243316

HYDRAULIC OIL FILTER RELIEF VALVE - CONTINUED

LOCATION	ITEM	ACTION REMARKS
DISASSEMBLY		
8. Housing (1)	Connector (2) with assembled spacer ring (3)	a. Place housing (1) in machinist's vise with vise jaw caps. b. Using 1 7/8-inch open-end wrench, unscrew and take out.
9. Connector (2)	Spacer ring (3)	a. Using pocket knife, take off. b. Get rid of.
10. Elbow (4) and housing (1)	Nut (5)	Using two 1 1/4-inch open-end wrenches, loosen.
11. Housing (1)	Elbow (4) with assembled parts	a. Note relative position for proper placement during assembly. b. Using 1 1/4-inch open-end wrench, unscrew and take out.
12. Elbow (4)	Packing (6)	a. Using pocket knife, take off. b. Get rid of.
13. Housing (1)	Union adapter (7) with assembled packing (8)	Using 1 11/4-inch open-end wrench, unscrew and take out.
14. Union adapter (7)	Packing (8)	a. Using pocket knife, take off. b. Get rid of.
15. Housing (1)	Connector (9) with assembled packing (10)	Using 1 1/4-inch open-end wrench, unscrew and take out.
16. Connector (9)	Packing (10)	a. Using pocket knife, take off. b. Get rid of.

WARNING

Surge relief valve plug is under strong spring tension. If plug is not supported, parts may fly off injuring personnel.

17. Housing (1)	Plug (11) with assembled packing (12)	Using 1 1/4-inch open-end wrench, unscrew and take out.
-----------------	---------------------------------------	---

HYDRAULIC OIL FILTER RELIEF VALVE - CONTINUED

LOCATION	ITEM	ACTION	REMARKS
18.	Surge relief valve spring (13) and valve (14)	Take out.	
19. Plug (11)	Packing (12)	a. Using pocket knife, take off. b. Get rid of.	
20. Housing (1)	Plug (15) with assembled packing (16)	Using 1-inch open-end wrench, unscrew and take out.	
21.	Valve (17) with assembled packing (18)	Using long roundnose pliers and magnetic retrieving tool, take out.	
22.	Filter relief valve spring (19)	a. Using long roundnose pliers and magnetic retrieving tool, take out. b. Take housing (1) out of machinist's vise with vise jaw caps.	
23. Plug (15)	Packing (16)	a. Using pocket knife, take off. b. Get rid of.	
24. Valve (17)	Packing (18)	a. Using pocket knife, take off. b. Get rid of.	

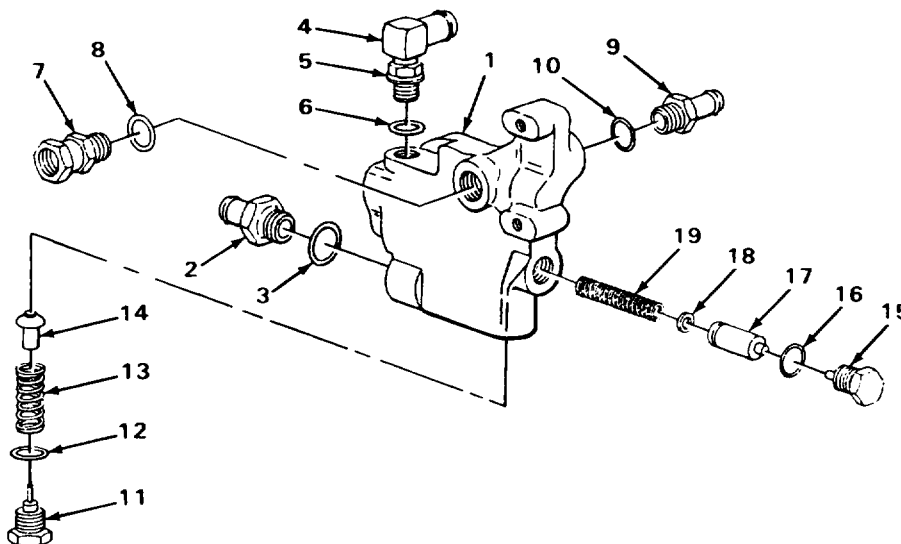

TA243317

HYDRAULIC OIL FILTER RELIEF VALVE - CONTINUED

LOCATION	ITEM	ACTION	REMARKS
----------	------	--------	---------

CLEANING

NOTE

For more information on how to clean parts, go to General Maintenance Instructions (page 2-137).

WARNING

Drycleaning solvent P-D-680 is toxic and flammable. Wear protective goggles and gloves and use only in a well ventilated area. Avoid contact with skin, eyes, and clothes and don't breathe vapors. Do not use near open flame or excessive heat. The flashpoint is 100°F to 138°F (38° to 59°C). If you become dizzy while using cleaning solvent, get fresh air immediately and get medical aid. If contact with eyes is made, wash your eyes with water and get medical aid immediately.

Compressed air used for blowing away chips, dirt, etc., must leave nozzle at less than 30 psi (207 kPa) to prevent personal injury. Be certain that nozzle is rated to provide a maximum of 30 psi (207 kPa). Be sure to wear safety goggles or lenses when using compressed air. Compressed air and particles moved by compressed air can cause damage to your eyes.

- | | | | |
|-----|-----------|----------------------------------|---|
| 25. | All parts | a. Clean in drycleaning solvent. | b. Using reciprocating air compressor, air compressor hose, and air blow gun, blow dry. |
|-----|-----------|----------------------------------|---|

INSPECTION/REPLACEMENT

NOTE

For more information on how to inspect parts, go to General Maintenance Instructions (page 2-137).

Replace defective parts which cannot be repaired.

- | | | | |
|-----|-------------------------------|---|--|
| 26. | Surge relief valve spring (1) | a. Look for cracks, breaks, and abnormal bends.
b. Using 4 to 400-pound capacity spring tester, measure free length. | Free length should be 2.0625 inches (52.3875 mm). |
|-----|-------------------------------|---|--|

HYDRAULIC OIL FILTER RELIEF VALVE - CONTINUED

LOCATION	ITEM	ACTION REMARKS
26. Continued		c. Using 4 to 400-pound capacity spring tester and 1/2-inch drive, 0 to 150 foot-pound capacity torque wrench, apply 34 foot-pounds (46 N•m) torque and measure compressed length. Compressed length should be 1.3125-inch (33.3375 mm).
27.	Oil filter relief valve spring (2)	a. Look for cracks, breaks, and abnormal bends. b. Using 4 to 400-pound capacity spring tester, measure free length. Free length should be 3.250 inches (82.55 mm). c. Using 4 to 400-pound capacity spring tester and 1/2-inch drive, 0 to 150 foot-pound capacity torque wrench, apply 18.5 foot-pounds (25 N•m) torque and measure compressed length. Compressed length should be 2.5 inches (63.5 mm).
28.	Two valves (3 and 4) and housing (5)	Look for cracks, breaks, and scores.
29.	All other parts	Look for cracks and breaks.
30.	All threaded parts	Look for damaged threads.

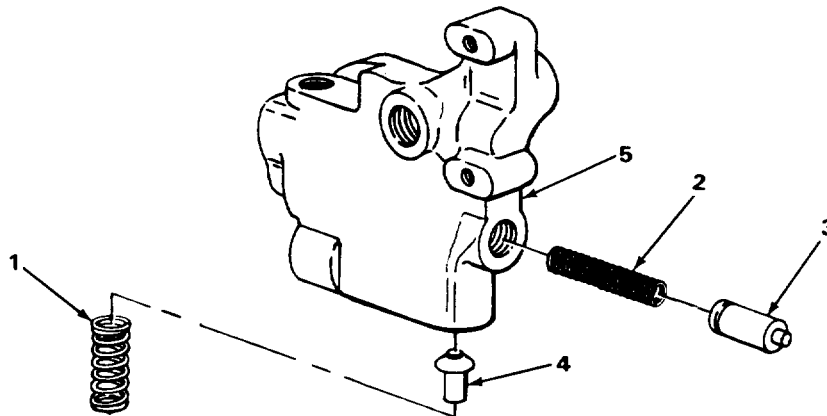

TA243318

HYDRAULIC OIL FILTER RELIEF VALVE - CONTINUED

LOCATION	ITEM	ACTION REMARKS
REPAIR		
31.	Housing (1)	If threads are damaged, using pipe thread set, restore threads.
ASSEMBLY		
32. Valve (2)	New packing (3)	Place in position.
33. Plug (4)	New packing (5)	Place in position.
34. Housing (1)	Valve (2) with assembled packing and oil filter relief valve spring (6)	a. Place housing (1) in machinist's vise with vise jaw caps. b. Place in position.
35.	Plug (4) with assembled packing (5)	Screw in and tighten using 1-inch open-end wrench.
36. Plug (7))	New packing (8)	Place in position.
37. Housing (1)	Surge relief valve spring (9) and valve (10)	Place in position.

WARNING

Surge relief valve plug is under strong spring tension. If plug is not supported, parts may fly off injuring personnel.

38.	Plug (7) with assembled packing (8)	Screw in and tighten using 1 1/4-inch open-end wrench.
39. Connector (11)	New packing (12)	Place in position.
40. Housing (1)	Connector (11) with assembled packing (12)	Screw in and tighten using 1 1/4-inch open-end wrench.
41. Union adapter (13)	New packing (14)	Place in position.

HYDRAULIC OIL FILTER RELIEF VALVE - CONTINUED

LOCATION	ITEM	ACTION	REMARKS
42. Housing (1)	Union adapter (13) with assembled packing (14)	Screw in and tighten using 1 1/4-inch open-end wrench.	
43. Elbow (15)	Nut (16)	Screw on all the way.	
44.	New packing (17)	Place in position.	
45. Housing (1)	Elbow (15) with assembled parts	Screw in and tighten to position noted during disassembly using 1 1/4-inch open- end wrench.	
46. Elbow (15) and housing (1)	Nut (16)	Using two 1 1/4-inch open-end wrenches, tighten until seated against housing (1).	
47. Connector (18)	New spacer ring (19)	Place in position.	
48. Housing (1)	Connector (18) with assembled spacer ring (19)	a Screw in and tighten using 1 7/8-inch open-end wrench. b Take housing (1) out of machinist's vise with vise jaw caps.	

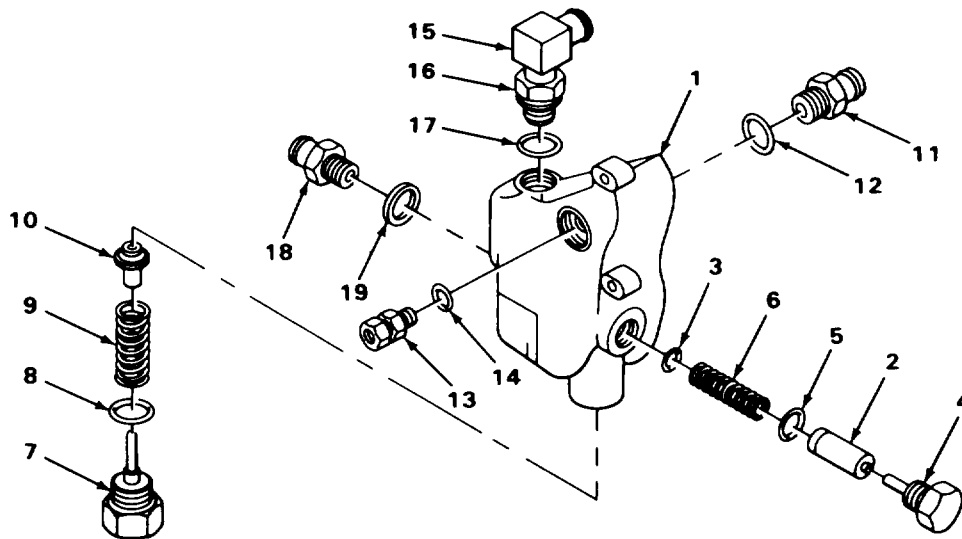

TA243319

HYDRAULIC OIL FILTER RELIEF VALVE - CONTINUED

LOCATION	ITEM	ACTION REMARKS
INSTALLATION		
49. Main frame (1) and two hoses (2 and 3)	Valve (4) with assembled parts	a. Uncap hoses (2 and 3). b. Place in position.
50. Main frame (1) and valve (4)	Two screws (5), washers (6), and new lockwashers (7)	Screw in and tighten using 9/16-inch, 3/8-inch drive socket and ratchet handle.
51. Hose (2)	Clamp (8)	a. Slide into position. b. Using 1/4-inch flat-tip screwdriver, tighten.
52. Union adapter (9)	Hose (10)	a. Uncap. b. Take off tag. Screw in and tighten using 1 1/8-inch and 1 1/4-inch open-end wrenches.
53. Hose (3)	Clamp (11)	a. Slide into position. b. Using 1/4-inch flat-tip screwdriver, tighten.
54. Two connectors (12 and 13)	Hose (14)	a. Uncap connector (13). b. Take off tag. c. Using 1/4-inch and 3/8-inch flat-tip screwdrivers, place in position.
55. Hose (14)	Two clamps (15 and 16)	a. Place in position. b. Using 1/4-inch flat-tip screwdriver, tighten.
56. Loader backhoe	Hydraulic oil filter	Install (page 2-1698).
57.	Engine	Start and run at high idle (TM 5-2420-222-10).

HYDRAULIC OIL FILTER RELIEF VALVE - CONTINUED

LOCATION	ITEM	ACTION	REMARKS
58.	Hydraulic oil filter relief valve	a. Check for leaks. b. If leaking at any connection, tighten using 1/4-inch flat-tip screwdriver or 1 1/8-inch and 1 1/4-inch open-end wrenches or 1 7/8-inch open-end wrench, or two 1 1/4-inch open-end wrenches or 1 1/4-inch open-end wrench or 1-inch open-end wrench. c. If leaking does not stop, shut down engine (TM 5-2420-222-10) and replace leaking connection packing or component as outlined in this task.	

NOTE
 If no leaks were found, skip step 59.

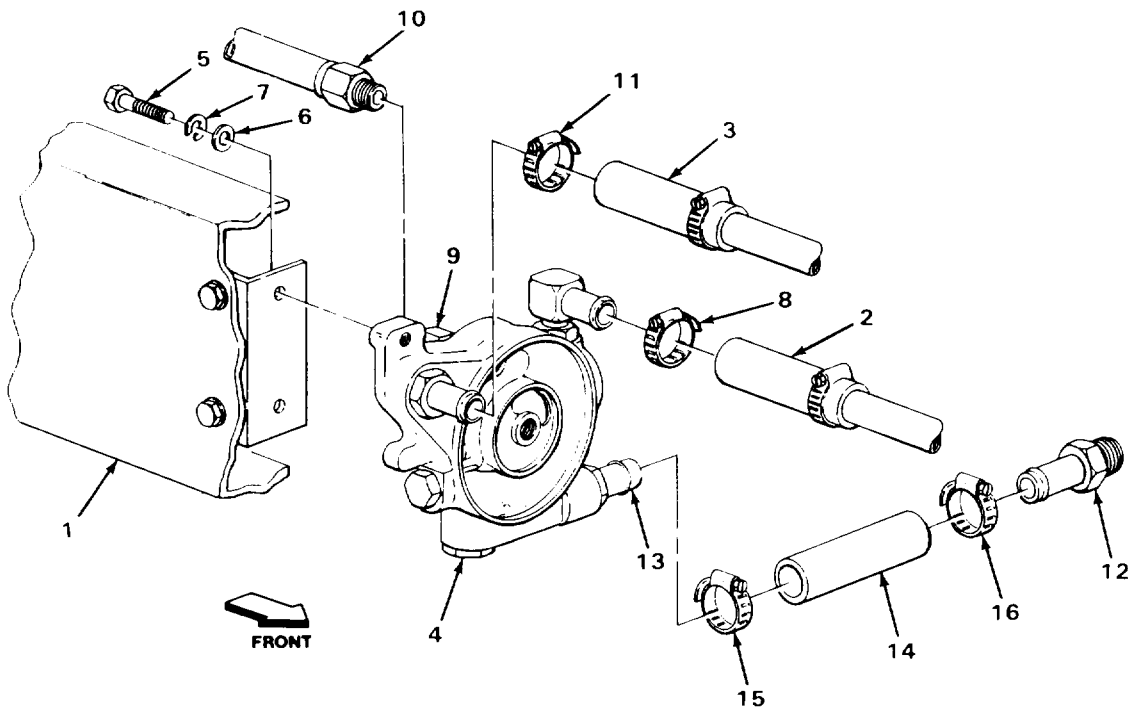

TA243320

HYDRAULIC OIL FILTER RELIEF VALVE - CONTINUED

LOCATION	ITEM	ACTION	REMARKS
INSTALLATION - CONTINUED			
59.	Loader backhoe	Transmission	a. Check fluid level and add proper amount and grade (TM 5-2420-222-10). b. Repeat step 58.
60.		Engine	If still running, shut down (TM 5-2420-222-10).

TASK ENDS HERE

HYDRAULIC IMPACTOR VALVE

This task covers:

- | | |
|---|-------------------------------|
| a. Removal (page 2-1229) | e. Repair (page 2-1233) |
| b. Disassembly (page 2-1230) | f. Assembly (page 2-1233) |
| c. Cleaning (page 2-1232) | g. Installation (page 2-1235) |
| d. Inspection/Replacement (page 2-1232) | |

INITIAL SETUP:

Tools

Handle, ratchet, 3/8-inch drive
Pan, drain
Pliers, slip-joint, multiple tongue and groove
Socket, 3/8-inch drive, 9/16-inch
Socket, deep, 3/8-inch drive, 9/16-inch
Threading set, screw
Vise, machinist's
Wrench, box, 9/16-inch
Wrench, open-end, 1 1/8-inch
Wrench, open-end, 11/4-inch
Wrench, plier

Materials/Part

Nut, stop, bracket screw
(two required)
Nut, stop, valve screw (two required)

Materials/Parts - Continued

Pin, cotter, link pin (two required)
Pin, cotter, pedal rod
Rags, wiping (item 21, Appendix C)
Solvent, drycleaning (item 28, Appendix C)
Tags, marking (item 30, Appendix C)

Personnel Required

Two

Equipment Condition

Hydraulic impactor flow regulator removed
(page 2-1237)

HYDRAULIC IMPACTOR VALVE - CONTINUED

LOCATION	ITEM	ACTION	REMARKS
REMOVAL			
1.	Pedal rod (1)	Pedal (2)	Using multiple tongue and groove slip-joint pliers, unscrew and take off.
2.	Elbow and packing assembly (3)	Hose (4)	<ol style="list-style-type: none"> Place drain pan underneath to catch draining fluid. Using 1 1/4-inch open-end wrench, unscrew and take off. Cap (page 2-137). Tag (page 2-137).
3.	Main frame (5), bracket (6), and spacer (7)	Two bolts (8), washers (9), and stop nuts (10)	<ol style="list-style-type: none"> With aid of assistant, using 9/16-inch, 3/8-inch drive socket, ratchet handle, and 9/16-inch box wrench, unscrew and take apart. Get rid of stop nuts (10).
4.	Main frame (5)	Bracket (6), valve (11) with assembled parts, and spacer (7)	<ol style="list-style-type: none"> Take off. Hold over drain pan to catch draining fluid. Get rid of drained fluid (page 2-137).

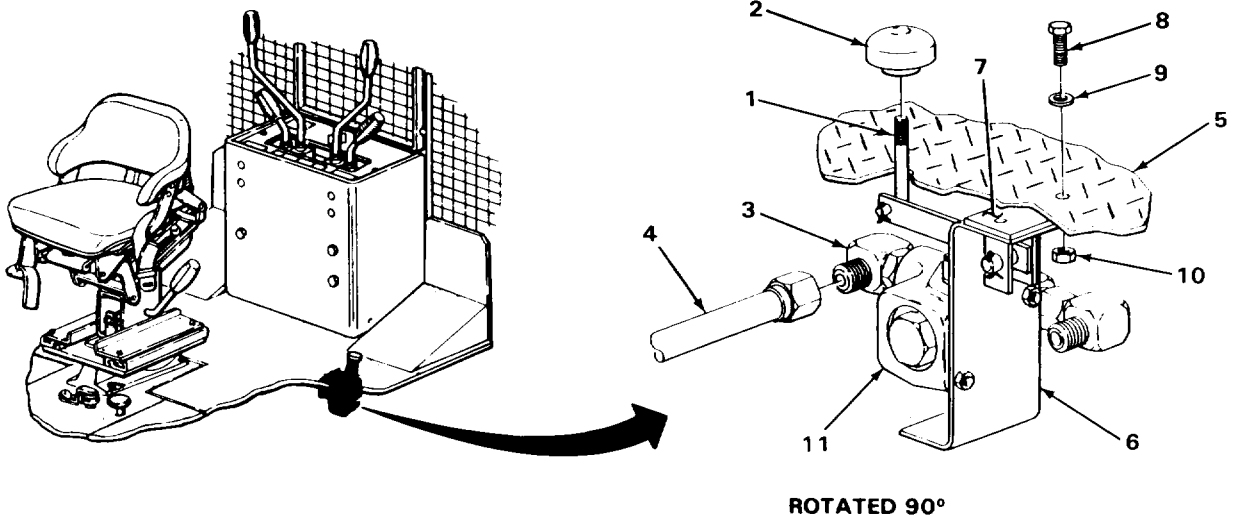

TA243321

HYDRAULIC IMPACTOR VALVE - CONTINUED

LOCATION	ITEM	ACTION REMARKS	
DISASSEMBLY			
5.	Bracket (1) and pin (2)	Cotter pin (3)	<ul style="list-style-type: none"> a. Position bracket (1) with assembled parts in machinist's vise. b. Using multiple tongue and groove slip-joint pliers, straighten ends and take out. c. Get rid of.
6.	Bracket (1) and link (4)	Pin (2)	Take out.
7.	Pedal rod (5) and link (4)	Cotter pin (6)	<ul style="list-style-type: none"> a. Using multiple tongue and groove slip-joint pliers, straighten ends and take out. b. Get rid of.
8.	Link (4)	Pedal rod (5)	Take out.
9.	Clevis (7) and pin (8)	Cotter pin (9)	<ul style="list-style-type: none"> a. Using multiple tongue and groove slip-joint pliers, straighten ends and take out. b. Get rid of.
10.	Clevis (7) and link (4)	Pin (8)	Take out.
11.	Clevis (7) and bracket (1)	Link (4)	<ul style="list-style-type: none"> a. Note relative position of holes for proper placement during assembly. b. Take out.
12.	Elbow and packing assembly (10)	Elbow (11)	<ul style="list-style-type: none"> a. Note relative position for proper placement during assembly. b. Using 1 1/4-inch open-end wrench, unscrew and take off.
13.	Valve (12) and two elbow and packing assemblies (10 and 13)	Two nuts (14 and 15)	Using 1 1/8-inch and 1 1/4-inch open-end wrenches, loosen.
14.	Valve (12)	Two elbow and packing assemblies (10 and 13)	<ul style="list-style-type: none"> a. Note relative position for proper placement during assembly. b. Using 1 1/8-inch open-end wrench, unscrew and take off.

HYDRAULIC IMPACTOR VALVE - CONTINUED

LOCATION	ITEM	ACTION REMARKS
15.	Clevis (7)	a. Using clean rag and multiple tongue and groove slip-joint pliers, hold valve (12). b. Using plier wrench, unscrew and take off.
16.	Washer (16)	Take off.
17.	Plug and packing assembly (17)	Using 1 1/4-inch open-end wrench, unscrew and take out. Do not get rid of packing at this time.

WARNING

Valve is under strong spring tension. If valve is not supported when mounting bolts are removed, parts may fly off injuring personnel.

18. Bracket (1) and valve (12)	Two bolts (18) and stop nuts (19)	a. Using 9/16-inch, 3/8-inch drive deep socket, ratchet handle, and 9/16-inch box wrench, unscrew and take apart. b. Get rid of stop nuts (19).
19. Bracket (1) and spring (20)	Valve (12)	Take off.
20. Bracket (1)	Spring (20)	a. Take off. b. Take bracket out of machinist's vise.

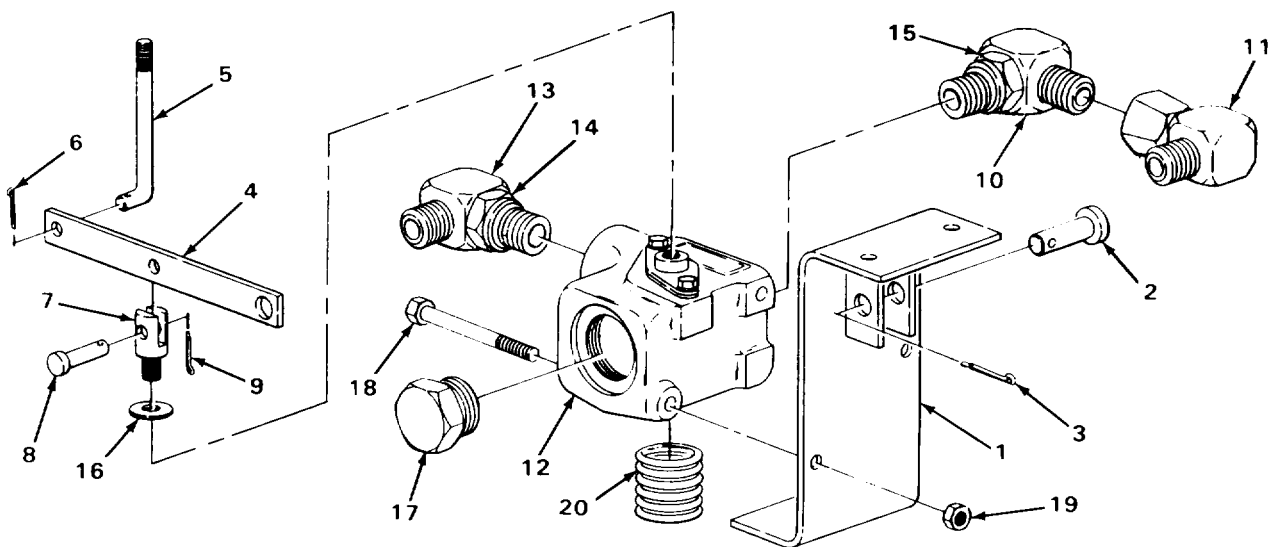

TA243322

HYDRAULIC IMPACTOR VALVE - CONTINUED

LOCATION	ITEM	ACTION	REMARKS
----------	------	--------	---------

CLEANING

NOTE

For more information on how to clean parts, go to General Maintenance Instructions (page 2-137).

21.	Two elbow and packing assemblies (1 and 2) and plug and packing assembly (3)	Using clean, dry rags, wipe clean.	
-----	--	------------------------------------	--

WARNING

Drycleaning solvent P-D-680 is toxic and flammable. Wear protective goggles and gloves and use only in a well ventilated area. Avoid contact with skin, eyes, and clothes and don't breathe vapors. Do not use near open flame or excessive heat. The flashpoint is 100°F to 138°F (38° to 59°C). If you become dizzy while using cleaning solvent, get fresh air immediately and get medical aid. If contact with eyes is made, wash your eyes with water and get medical aid immediately.

22.	Valve (4)	a. Using clean rags dampened with dry-cleaning solvent, wipe clean. b. Using clean, dry rags, wipe dry.	
23.	All other metal parts	a. Clean in drycleaning solvent. b. Using clean, dry rags, wipe dry.	

INSPECTION/REPLACEMENT

NOTE

For more information on how to inspect parts, go to General Maintenance Instructions (page 2-137).

Replace defective parts which cannot be repaired.

24.	Two elbow and packing assemblies (1 and 2) and plug and packing assembly (3)	a. Look for cracks and breaks. b. Look for damaged packings. If packings are damaged, assemblies must be replaced.	
-----	--	---	--

HYDRAULIC IMPACTOR VALVE - CONTINUED

LOCATION	ITEM	ACTION	REMARKS
25.	All other metal parts		Look for cracks, breaks, and abnormal bends.
26.	All threaded parts		Look for damaged threads.
REPAIR			
27.	Bracket (5)		If cracked, weld (TM 9-237).
28.	Pedal rod (6) and pedal (7)		If threads are damaged, using screw threading set, restore threads.
ASSEMBLY			
29.	Bracket (5)	Spring (8)	a. Position bracket in machinist's vise. b. Place in position.
30.	Bracket (5) and spring (8)	Valve (4)	Place in position.

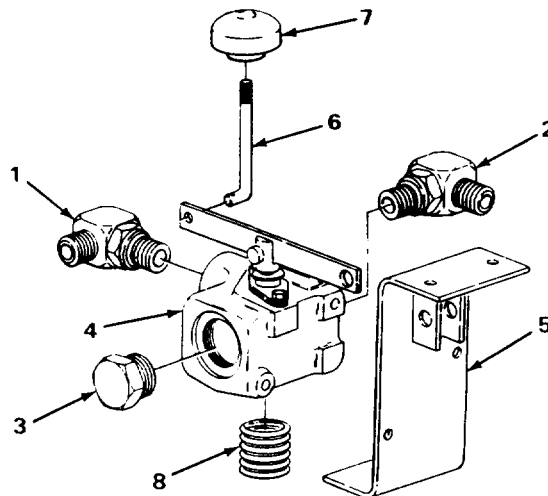

TA243323

HYDRAULIC IMPACTOR VALVE - CONTINUED

LOCATION	ITEM	ACTION REMARKS
ASSEMBLY - CONTINUED		
31. Bracket (1) and valve (2)	Two bolts (3) and new stop nuts (4)	Screw together and tighten using 9/16-inch, 3/8-inch drive deep socket, ratchet handle, and 9/16-inch box wrench.
32. Valve (2)	Plug and packing assembly (5)	Screw in and tighten using 1 1/4-inch open-end wrench.
33.	Washer (6)	Place in position.
34.	Clevis (7)	a. Using clean rag and multiple tongue and groove slip-joint pliers, hold valve (2). b. Screw in and tighten using plier wrench.
35. Two elbow and packing assemblies (8 and 9)	Two nuts (10 and 11)	Screw on all the way by hand.
36. Valve (2)	Two elbow and packing assemblies (8 and 9)	Screw in and tighten to position noted during disassembly using 1 1/8-inch open-end wrench.
37. Valve (2) and two elbow and packing assemblies (8 and 9)	Two nuts (10 and 11)	Using 1 1/8-inch and 1 1/4-inch open-end wrenches, tighten until seated against valve (2).
38. Elbow and packing assembly (9)	Elbow (12)	Screw on and tighten to position noted during disassembly using 1 1/4-inch open-end wrench.
39. Clevis (7) and bracket (1)	Link (13)	Place in position noted during disassembly.
40. Clevis (7) and link (13)	Pin (14)	Place in position.
41. Clevis (7) and pin (14)	New cotter pin (15)	a. Place in position. b. Using multiple tongue and groove slip-joint pliers, bend ends back.
42. Link (13)	Pedal rod (16)	Place in position.

HYDRAULIC IMPACTOR VALVE - CONTINUED

LOCATION	ITEM	ACTION	REMARKS
43. Pedal rod (16) and link (13)	New cotter pin (17)	a. Place in position. b. Using multiple tongue and groove slip-joint pliers, bend ends back.	
44. Bracket (1) and link (13)	Pin (18)	a. Aline holes in bracket (1) and link (13). b. Place in position.	
45. Bracket (1) and pin (18)	New cotter pin (19)	a. Place in position. b. Using multiple tongue and groove slip-joint pliers, bend ends back.	

INSTALLATION

46. Main frame (20)	Bracket (1), valve (2) with assembled parts and spacer (21)	Place in position.
---------------------	---	--------------------

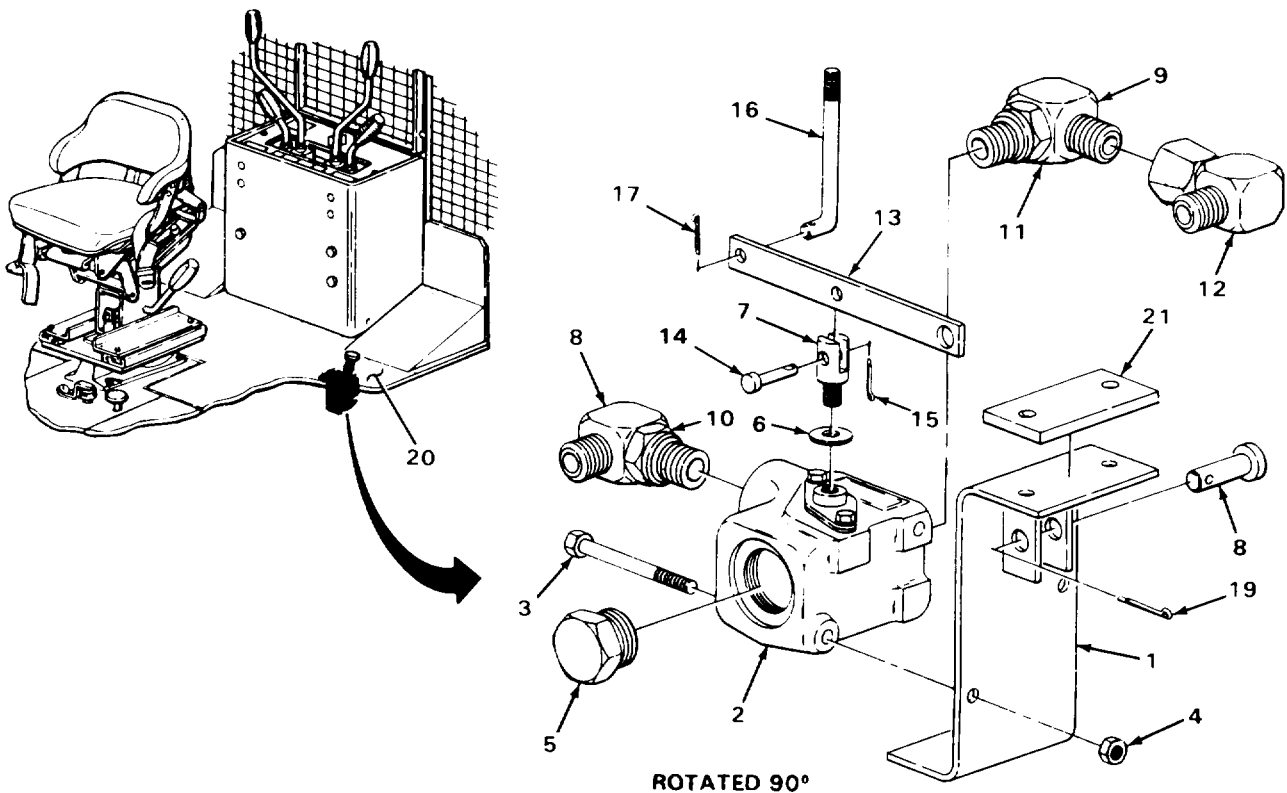

TA243324

HYDRAULIC IMPACTOR VALVE - CONTINUED

LOCATION	ITEM	ACTION	REMARKS
INSTALLATION - CONTINUED			
47.	Main frame (1), spacer (2), and bracket (3)	Two bolts (4), washers (5), and new stop nuts (6)	With aid of assistant, screw together and tighten using 9/16-inch, 3/8-inch drive socket, ratchet handle, and 9/16-inch box wrench.
48.	Elbow (7)	Hose (8)	a. Uncap. b. Take off tag. c. Screw on and tighten using 1 1/4-inch open-end wrench.
49.	Pedal rod (9)	Pedal (10)	Screw on and tighten using multiple tongue and groove slip-joint pliers.
50.	Loader backhoe	Hydraulic impactor flow regulator	Install (page 2-1237).
51.		Engine	Start and run at high idle (TM 5-2420-222-10).
52.		Hydraulic impactor valve	a. Operate (TM 5-2420-222-10) and check for leaks. b. If leaking at any connection, tighten using 1 1/4-inch open-end wrench or 1 1/8-inch open-end wrench or 1 1/8-inch and 1 1/4-inch open-end wrenches. c. If leaking does not stop, replace defective fitting or valve component as outlined in this task.
NOTE			
If not leaks were found, skip step 53.			
53.		Transmission	a. Check fluid level and add proper amount and grade (TM 5-2420-222-10). b. Repeat steps 51 and 52.
54.		Engine	If still running, shut down (TM 5-2420-222-10).

HYDRAULIC IMPACTOR VALVE - CONTINUED

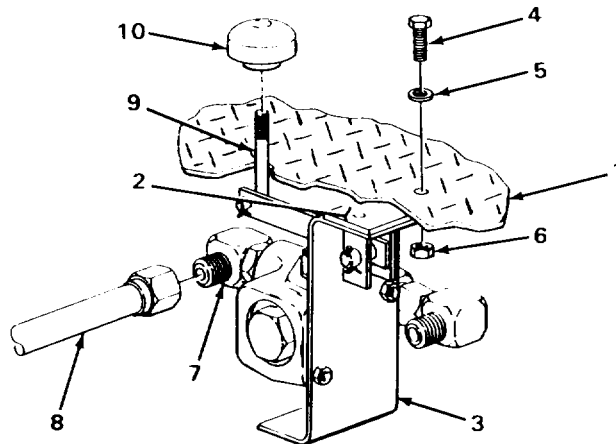

TASK ENDS HERE

HYDRAULIC IMPACTOR FLOW REGULATOR

This task covers:

- | | |
|---|-------------------------------|
| a. Removal (page 2-1238) | e. Repair (page 2-1240) |
| b. Disassembly (page 2-1235) | f. Assembly (page 2-1240) |
| c. Cleaning (page 2-1238) | g. Installation (page 2-1240) |
| d. Inspection/Replacement (page 2-1239) | |

INITIAL SETUP:

Tools

- Pan, drain
- Thread set, pipe
- Vise, machinist's
- Wrench, open-end, 1 1/8-inch
- Wrench, open-end, 1 1/4-inch (two required)

Materials/Parts

- Rags, wiping (item 21, Appendix C)
- Solvent, drycleaning (item 28, Appendix A)
- Tags, marking (item 30, Appendix C)

Personnel Required

One

Equipment Condition

Hydraulic system pressure released
(page 2-1191)

TA243325

HYDRAULIC IMPACTOR FLOW REGULATOR - CONTINUED

LOCATION	ITEM	ACTION	REMARKS
----------	------	--------	---------

REMOVAL

WARNING

Do not attempt to disconnect hydraulic lines and fittings while engine is running or before hydraulic system pressure has been released. When engine is running, hydraulic system is under pressure. Hydraulic system pressure should be 0 psi (0 kPa) before lines are disconnected. A line or fitting disconnected under pressure will blow off with a lot of force and could cause serious injury to personnel.

Be careful when draining hot fluids. Wear gloves to protect your hands from hot parts and fluids or severe burns could result.

- | | | |
|--------------|---|---|
| 1. Elbow (1) | Hose (2) | <ul style="list-style-type: none"> a. Place drain pan underneath to catch draining fluid. b. Using 1 1/8-inch and 1 1/4-inch open-end wrenches, unscrew and take off. c. Cap (page 2-137). d. Tag (page 2-137). |
| 2. Elbow (3) | Adapter (4) with assembled flow regulator (5) and elbow (1) installation. | <ul style="list-style-type: none"> a. Place drain pan underneath to catch draining fluid. b. Note relative position of elbow (1) for proper placement during c. Using 1 1/4-inch open-end wrench, unscrew and take out. d. Cap elbow (3) (page 2-137). e. Get rid of drained fluid (page 2-137). |

DISASSEMBLY

- | | | |
|-----------------------|-------------|---|
| 3. Flow regulator (5) | Elbow (1) | <ul style="list-style-type: none"> a. Place flow regulator (5) in machinist's vise. b. Using 1 1/4-inch open-end wrench, unscrew and take out. |
| 4. | Adapter (4) | <ul style="list-style-type: none"> a. Using two 1 1/4-inch open-end wrenches, unscrew and take out. b. Take flow regulator (5) out of machinist's vise. |

CLEANING

NOTE

For more information on how to clean parts, go to General Maintenance Instructions (page 2-137).

HYDRAULIC IMPACTOR FLOW REGULATOR - CONTINUED

LOCATION	ITEM	ACTION	REMARKS
----------	------	--------	---------

WARNING

Drycleaning solvent P-D-680 is toxic and flammable. Wear protective goggles and gloves and use only in a well ventilated area. Avoid contact with skin, eyes, and clothes and don't breathe vapors. Do not use near open flame or excessive heat. The flashpoint is 100°F to 138°F (38° to 59°C). If you become dizzy while using cleaning solvent, get fresh air immediately and get medical aid. If contact with eyes is made, wash your eyes with water and get medical aid immediately.

5.	All parts	a. Clean in drycleaning solvent. b. Using clean, dry rags, wipe dry.	
----	-----------	---	--

INSPECTION/REPLACEMENT

NOTE

For more information on how to inspect parts, go to **General Maintenance Instructions (page 2-137)**.

Replace defective parts which cannot be repaired.

6.	All parts	a. Look for cracks and breaks. b. Look for damaged threads.	
----	-----------	--	--

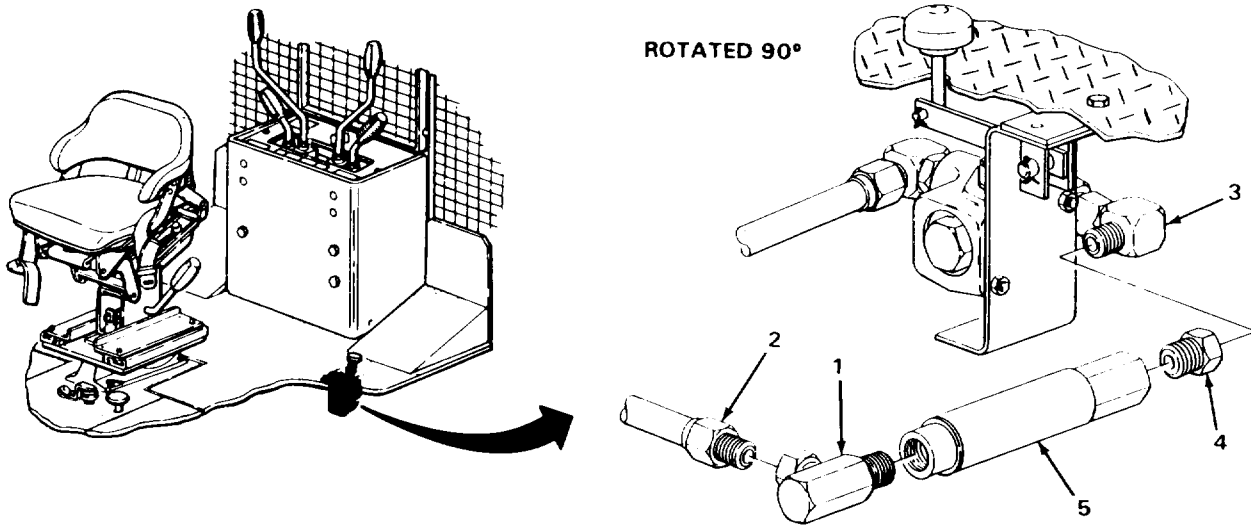

TA243325

HYDRAULIC IMPACTOR FLOW REGULATOR - CONTINUED

LOCATION	ITEM	ACTION REMARKS
REPAIR		
7.	Flow regulator (1)	If threads are damaged, using pipe thread set, restore damaged threads.
ASSEMBLY		
8.	Flow regulator (1)	Adapter (2)
		<ul style="list-style-type: none"> a. Place flow regulator (1) in machinist's vise. b. Screw in and tighten using 1 1/4-inch open-end wrench. <p style="text-align: center;">Adapter screws into hex shaped end of flow regulator.</p>
9.	Elbow (3)	<ul style="list-style-type: none"> a. Screw in and tighten two using 1 1/4-inch open-end wrenches. b. Take flow regulator (1) out of machinist's vise.
INSTALLATION		
10.	Elbow (4)	Adapter (2) with assembled flow regulator (1) and elbow (3)
		<ul style="list-style-type: none"> a. Uncap elbow (4). b. Screw on and tighten until elbow (3) is in same relative position as noted during removal using 1 1/4-inch open-end wrench.
11.	Elbow (3)	Hose (5)
		<ul style="list-style-type: none"> a. Uncap. b. Take off tag. c. Screw in and tighten using 1 1/8-inch and 1 1/4-inch open-end wrenches.
12.	Loader backhoe	Transmission
		Check fluid level and add proper amount and grade (TM 5-2420-222-10). Do not shut down engine at this time.
13.	Engine	Run at high idle (TM 5-2420-222-10).
14.	Hydraulic impactor flow regulator	<ul style="list-style-type: none"> a. Operate impactor(TM 5-2420-222-10) and check for leaks. b. If leaking at any connection, tighten using 1 1/8-inch and/or 1 1/4-inch open-end wrenches.

HYDRAULIC IMPACTOR FLOW REGULATOR - CONTINUED

LOCATION	ITEM	ACTION	REMARKS
14. Continued		<ul style="list-style-type: none"> c. If leaking does not stop, shut down engine (TM 5-2420-222-10) and replace defective flow regulator or fittings as outlined in this task. d. If leaks were found, repeat steps 12 thru 14. 	
15.		<p>If still running, shut down (TM 5-2420-222-20-10).</p>	

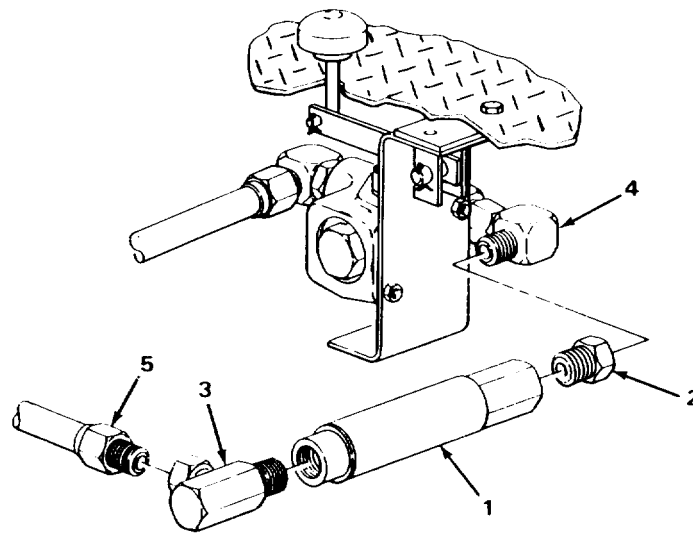

TA243326

TASK ENDS HERE

JAW CONTROL VALVE (SERIAL NUMBERS 235786 THRU 235999 ONLY)

This task covers:

- a. Removal (page 2-1242)
- b. Disassembly (page 2-1244)
- c. Cleaning (page 2-1246)
- d. Inspection/Replacement (page 2-1246)
- e. Repair (page 2-1246)
- f. Assembly (page 2-1248)

INITIAL SETUP:

Tools

- Caps, vise jaw (pair)
- Handle, ratchet, 3/8-inch drive
- Knife, pocket
- Pan, drain
- Pliers, long roundnose
- Socket, deep, 3/8-inch drive, 9/16-inch
- Vise, machinist's
- Wrench, box and open-end, combination 9/16-inch
- Wrench, open-end, 1 1/2-inch
- Wrench, open-end, 7/8-inch

Materials/Parts

- Lockwasher, valve screw (two required)
- Packing, adapter-to-valve (two required)
- Packing, bulkhead elbow-to-valve (two required)
- Packing, plug-to-valve
- Pin, cotter, valve link
- Rags, wiping (item 21, Appendix C)
- Solvent, drycleaning (item 28, Appendix A)
- Tags, marking (item 30, Appendix C)

Personnel Required

One

Equipment Condition

1. Hydraulic system pressure released (page 2-1191)
2. Rear platform removed (page 2-1117)

LOCATION	ITEM	ACTION	REMARKS
----------	------	--------	---------

REMOVAL

WARNING

Do not attempt to disconnect hydraulic lines and fittings while engine is running or before hydraulic system pressure has been released. When engine is running, hydraulic system is under pressure. Hydraulic system pressure should be 0 psi (0 kPa) before lines are disconnected. A line or fitting disconnected under pressure will blow off with a lot of force and could cause serious injury to personnel.

Be careful when draining hot fluids. Wear gloves to protect your hands from hot parts and fluids or severe burns could result.

JAW CONTROL VALVE (SERIAL NUMBERS 235786 THRU 235999 ONLY) - CONTINUED

LOCATION	ITEM	ACTION	REMARKS
1. Elbow (1)	Hose (2)	a. Place drain pan underneath to catch draining fluid. b. Using open-end wrench, unscrew and take off. c. Plug (page 2-137). d. Tag (page 2-137).	
2. Adapter (3)	Hose (4)	a. Place drain pan underneath to catch draining fluid. b. Using open-end wrench, unscrew and take off. c. Plug (page 2-137). d. Tag (page 2-137).	

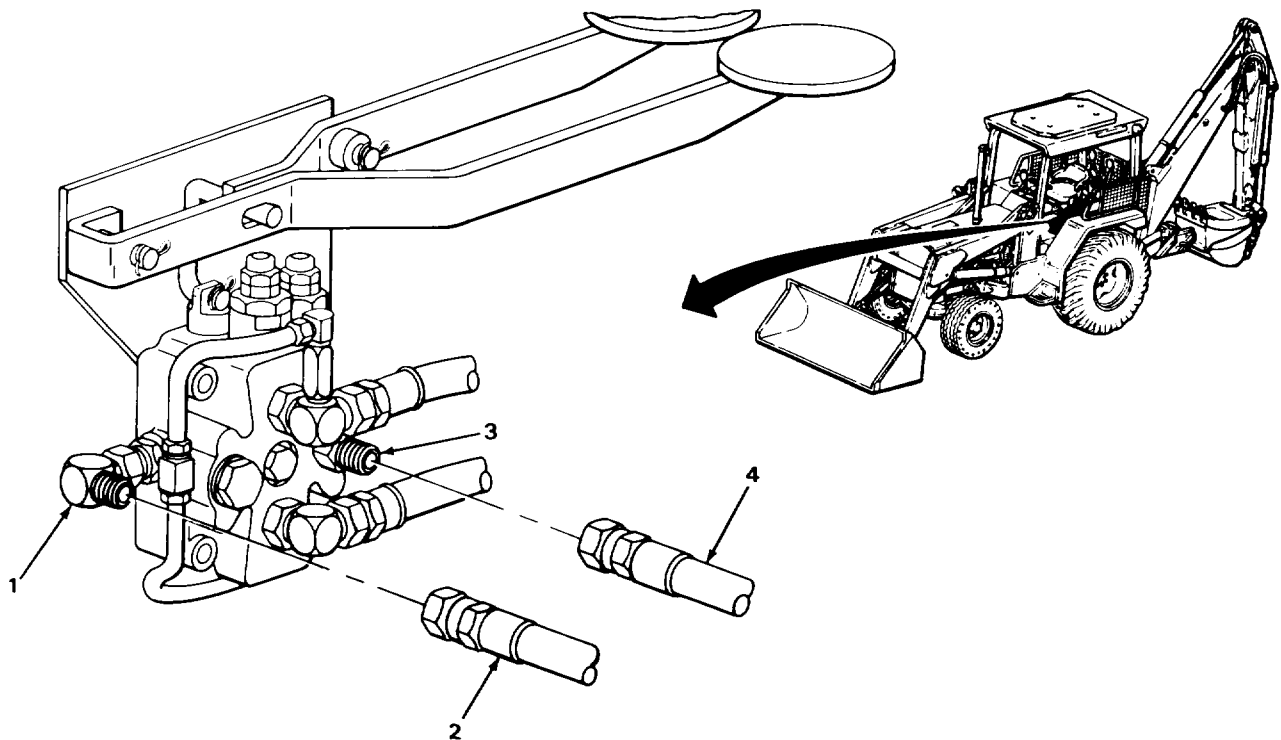

JAW CONTROL VALVE (SERIAL NUMBERS 235786 THRU 235999 ONLY) - CONTINUED

LOCATION	ITEM	ACTION	REMARKS
REMOVAL - CONTINUED			
3.	Two bulkhead elbows (1 and 2)	Two hoses (3 and 4)	<ol style="list-style-type: none"> Place drain pan underneath to catch draining fluid. Using 7/8-inch open-end wrench, unscrew and take off. Plug (page 2-137). Tag (page 2-137).
4.	Link (5) and valve (6)	Cotter pin (7)	<ol style="list-style-type: none"> Using long roundnose pliers, bend ends straight and take out. Get rid of.
5.	Valve (6) and bracket (8)	Two screws (9), lockwashers (10), and nuts (11)	<ol style="list-style-type: none"> Using 9/16-inch, 3/8-inch drive deep socket, ratchet handle, and 9/16-inch combination box and open-end wrench, unscrew and take apart. Top screw will stay in bracket. Get rid of lockwashers (10).
6.	Link (5) and bracket (8)	Valve (6) with assembled parts	<ol style="list-style-type: none"> Take off. Get rid of drained fluid (page 2-137).
DISASSEMBLY			
7.	Valve (6)	Jaw control (direct linear) valve tubes and fittings	Remove (page 2-1391).
8.		Adapter (12) with assembled elbow (13) and packing (14)	<ol style="list-style-type: none"> Place valve (6) in machinist's vise with vise jaw caps. Note relative position of elbow (13) for proper placement during assembly. Using open-end wrench, unscrew and take off.
9.	Adapter (12)	Packing (14)	<ol style="list-style-type: none"> Using pocket knife, take off. Get rid of.
10.	Valve (6)	Adapter (15) with assembled packing (16)	Using open-end wrench, unscrew and take off.
11.	Adapter (15)	Packing (16)	<ol style="list-style-type: none"> Using pocket knife, take off. Get rid of.

JAW CONTROL VALVE (SERIAL NUMBERS 235786 THRU 235999 ONLY) - CONTINUED

LOCATION	ITEM	ACTION REMARKS
12. Two bulkhead elbows (1 and 2) and valve (6)	Two nuts (17 and 18)	Using open-end wrenches, loosen.
13. Valve (6)	Two bulkhead elbows (1 and 2) with assembled parts	a. Note relative position for proper placement during assembly. b. Using open-end wrench, unscrew and take out.
14. Two bulkhead elbows (1 and 2)	Two packings (19 and 20)	a. Using pocket knife, take off. b. Get rid of.
15. Valve(6)	Plug (21) with assembled packing (22)	a. Using 1 1/2-inch open-end wrench, unscrew and take off. b. Take out of machinist's vise with vise jaw caps.
16. Plug (21)	Packing (22)	a. Using pocket knife, take off. b. Get rid of.

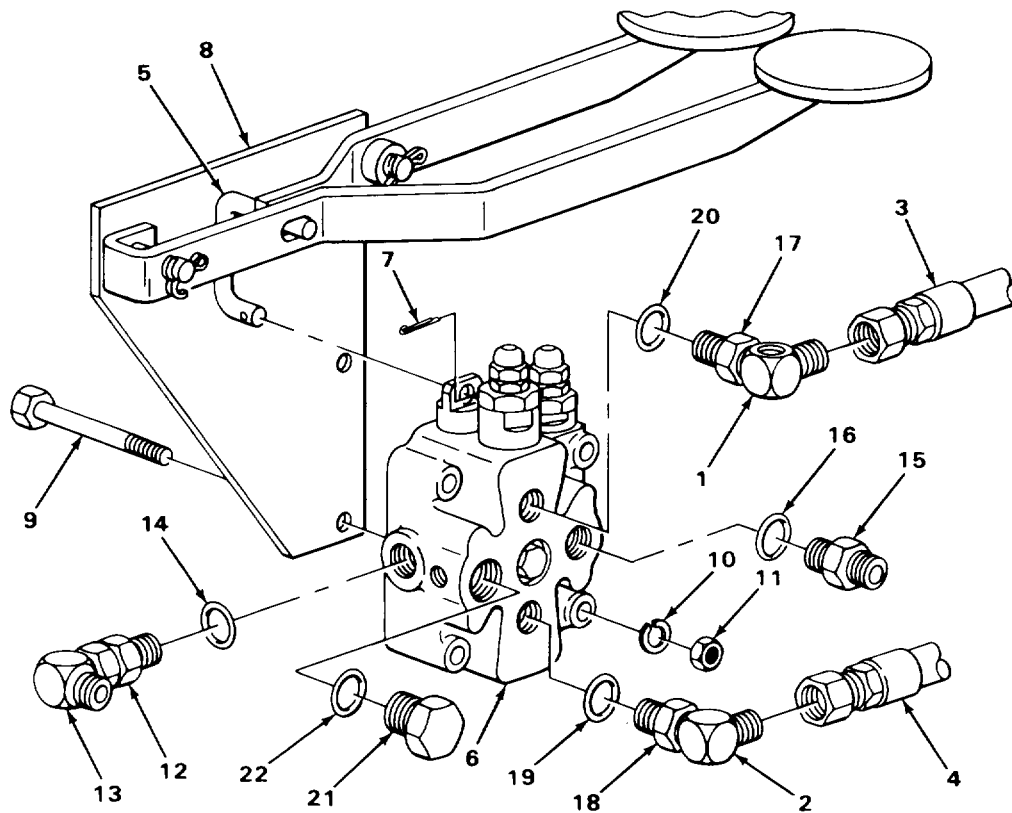

TA243328

JAW CONTROL VALVE (SERIAL NUMBERS 235786 THRU 235999 ONLY) - CONTINUED

LOCATION	ITEM	ACTION	REMARKS
CLEANING			
NOTE			
For more information on how to clean parts, go to General Maintenance Instructions (page 2-137) .			
<u>WARNING</u>			
Dry-cleaning solvent P-D-680 is toxic and flammable. Wear protective goggles and gloves and use only in a well ventilated area. Avoid contact with skin, eyes, and clothes and don't breathe vapors. Do not use near open flame or excessive heat. The flashpoint is 100°F to 138°F (38° to 59°C). If you become dizzy while using cleaning solvent, get fresh air immediately and get medical aid. If contact with eyes is made, wash your eyes with water and get medical aid immediately.			
17.	Valve (1)	a. Using clean rags dampened with dry-cleaning solvent, wipe clean. b. Using clean, dry rags, wipe dry.	
18.	All other metal parts	a. Clean in dry-cleaning solvent. b. Using clean, dry rags, wipe dry.	
INSPECTION/REPLACEMENT			
NOTE			
For more information on how to inspect parts, go to General Maintenance Instructions (page 2-137) . Replace defective parts as needed.			
19.	All metal parts	Look for cracks and breaks.	
20.	All threaded parts	Look for damaged threads.	
ASSEMBLY			
21. Plug (2)	New packing (3)	Place in position.	
22. Valve (1)	Plug (2) with assembled packing (3) open-end wrench.	a. Place valve (1) in machinist's vise with vise jaw caps. b. Screw in and tighten using 1 1/2-inch	

JAW CONTROL VALVE (SERIAL NUMBERS 235786 THRU 235999 ONLY) - CONTINUED

LOCATION	ITEM	ACTION	REMARKS
23. Two bulkhead elbows (4 and 5)	Two nuts (6 and 7)	Screw on all the way.	
24.	Two new packings (8 and 9)	Place in position.	
25. Valve (1)	Two bulkhead elbows (4 and 5) with assembled parts	Screw in and tighten to same relative position noted during disassembly, using open-end wrench.	
26. Valve (1) and two bulkhead elbows (4 and 5)	Two nuts (6 and 7)	Using open-end wrenches, tighten until seated against valve (1).	
27. Adapter (10)	New packing (11)	Place in position.	
28. Valve (1)	Adapter (10) with assembled packing (11)	Screw in and tighten using open-end wrench.	
29. Adapter (12)	New packing (13)	Place in position.	
30. Valve (1)	Adapter (12) with assembled elbow (14) and packing (13) wrench.	Screw in and tighten until elbow (14) is in same relative position noted during disassembly, using open-end wrench.	

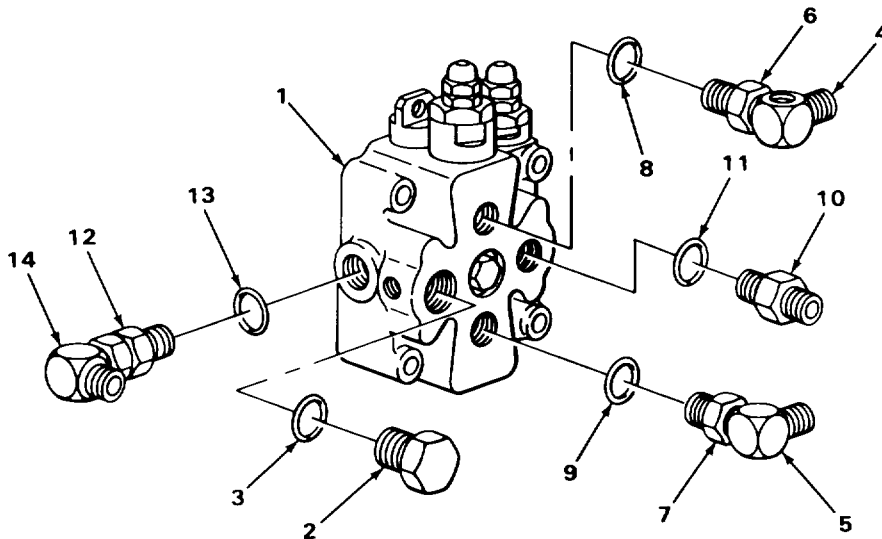

JAW CONTROL VALVE (SERIAL NUMBERS 235786 THRU 235999 ONLY) - CONTINUED

LOCATION	ITEM	ACTION	REMARKS
ASSEMBLY - CONTINUED			
31. Valve	Jaw control (direct linear) valve tubes and fittings	Install (page 2-1391).	
INSTALLATION			
32. Link (1) and bracket (2)	Valve (3) with assembled parts	a. Slide link (1) into hole in valve plunger. b. Place in position.	
33. Valve (3) and bracket (2)	Two screws (4), new lockwashers (5), and nuts (6) and open-end wrench.	Screw together and tighten using 9/16-inch, 3/8-inch drive deep socket, ratchet handle, and 9/16-inch combination box	
34. Link (1) and valve (3)	New cotter pin (7)	a. Place in position. b. Using long roundnose pliers, bend ends back.	
35. Two bulkhead elbows (8 and 9)	Two hoses (10 and 11)	a. Unplug. b. Take off tags. c. Screw in and tighten using 7/8-inch open-end wrench.	
36. Adapter (12)	Hose (13)	a. Unplug. b. Take off tag. c. Screw in and tighten using open-end wrench.	
37. Elbow (14)	Hose (15)	a. Unplug. b. Take off tag. c. Screw in and tighten using open-end wrench.	
38. Loader backhoe	Transmission	Check oil level and add proper amount and grade (TM 5-2420-222-10).	
39.	Engine	Start and run at high idle (TM 5-2420-222-10).	

JAW CONTROL VALVE (SERIAL NUMBERS 235786 THRU 235999 ONLY) - CONTINUED

LOCATION	ITEM	ACTION	REMARKS
40.	Jaw control valve	a. Operate jaw cylinder (TM 5-2420-222-10) and check for leaks. b. If leaking at any connection, tighten using 7/8-inch open-end wrench or 1 1/2-inch open-end wrench. c. If leaking does not stop, shut down (TM 5-2420-222-10) and replace leaking connection packing, fitting, or valve as outlined in this task. d. If found leaking, repeat steps 38 thru 40.	
41.	Engine	If still running, shut down (TM 5-2420-222-10).	

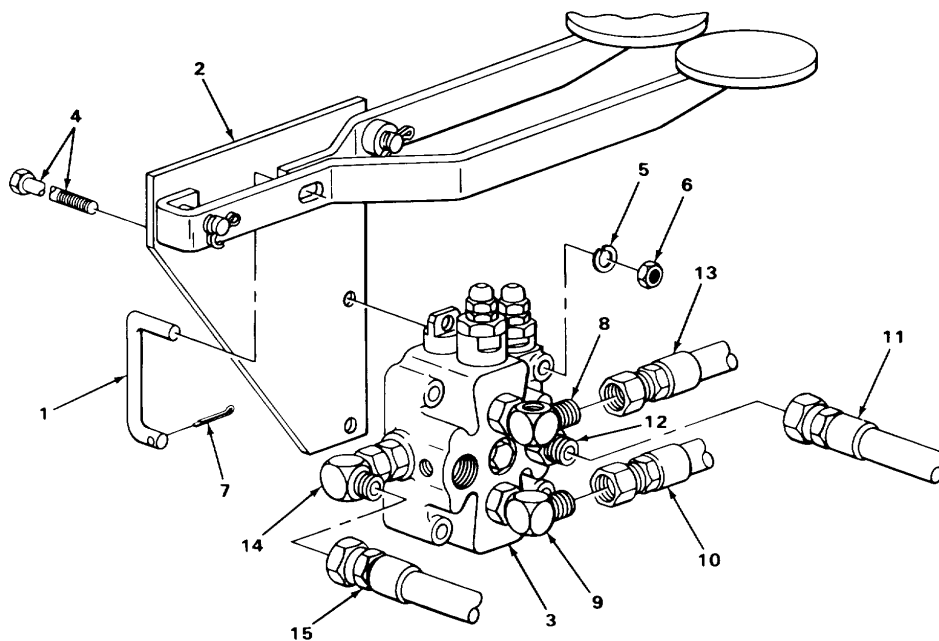

TA243330

JAW CONTROL VALVE (SERIAL NUMBERS 235786 THRU 235999 ONLY) - CONTINUED**NOTE**

FOLLOW-ON MAINTENANCE: Install rear platform (page 2-1117).

TASK ENDS HERE**JAW DIRECT LINEAR VALVE (SERIAL NUMBERS 319995 THRU 342573 ONLY)**

This task covers:

- | | |
|------------------------------|---|
| a. Removal (page 2-1251) | d. Inspection/Replacement (page 2-1255) |
| b. Disassembly (page 2-1252) | e. Assembly (page 2-1255) |
| c. Cleaning (page 2-1254) | f. Installation (page 2-1256) |
-

INITIAL SETUP**Tools**

Caps, vise jaw (pair)
 Handle, ratchet, 3/8-inch drive
 Knife, pocket
 Pan, drain
 Pliers, long roundnose
 Socket, deep, 3/8-inch drive,
 9/16-inch
 Vise, machinist's
 Wrench, box and open-end,
 combination 9/16-inch
 Wrench, open-end, 13/16-inch
 Wrench, open-end, 7/8-inch
 Wrench, open-end, 1 1/4-inch
 (two required)
 Wrench, open-end, 1 1/2-inch

Materials/Parts

Lockwasher, valve screw (two required)
 Packing, bulkhead elbow-to-valve
 (two required)

Materials/Parts - Continued

Packing, connector-to-valve
 Packing, connector-to-valve
 Packing, plug-to-valve
 Pin, cotter, valve link
 Rags, wiping (item 21, Appendix C)
 Solvent, dry-cleaning (item 28, Appendix C)
 Tags, marking (item 30, Appendix C)

Personnel Required

One

Equipment Condition

1. Hydraulic system pressure released (page 2-1191)
2. Left rear platform removed (page 2-1114)
3. Right rear platform removed (page 2-1110)

JAW DIRECT LINEAR VALVE (SERIAL NUMBERS 319995 THRU 342573 ONLY) - CONTINUED

LOCATION	ITEM	ACTION	REMARKS
----------	------	--------	---------

REMOVAL

WARNING

Do not attempt to disconnect hydraulic lines and fittings while engine is running or before hydraulic system pressure has been released. When engine is running, hydraulic system is under pressure. Hydraulic system pressure should be 0 psi (0 kPa) before lines are disconnected. A line or fitting disconnected under pressure will blow off with a lot of force and could cause serious injury to personnel.

Be careful when draining hot fluids. Wear gloves to protect your hands from hot parts and fluids or severe burns could result.

- | | | |
|------------------|------------------------------|--|
| 1. Connector (1) | Tee (2) with assembled parts | <ul style="list-style-type: none"> a. Place drain pan underneath to catch draining fluid. b. Using two 1 1/4-inch open-end wrenches, unscrew and take off. c. Cap (page 2-137). |
|------------------|------------------------------|--|

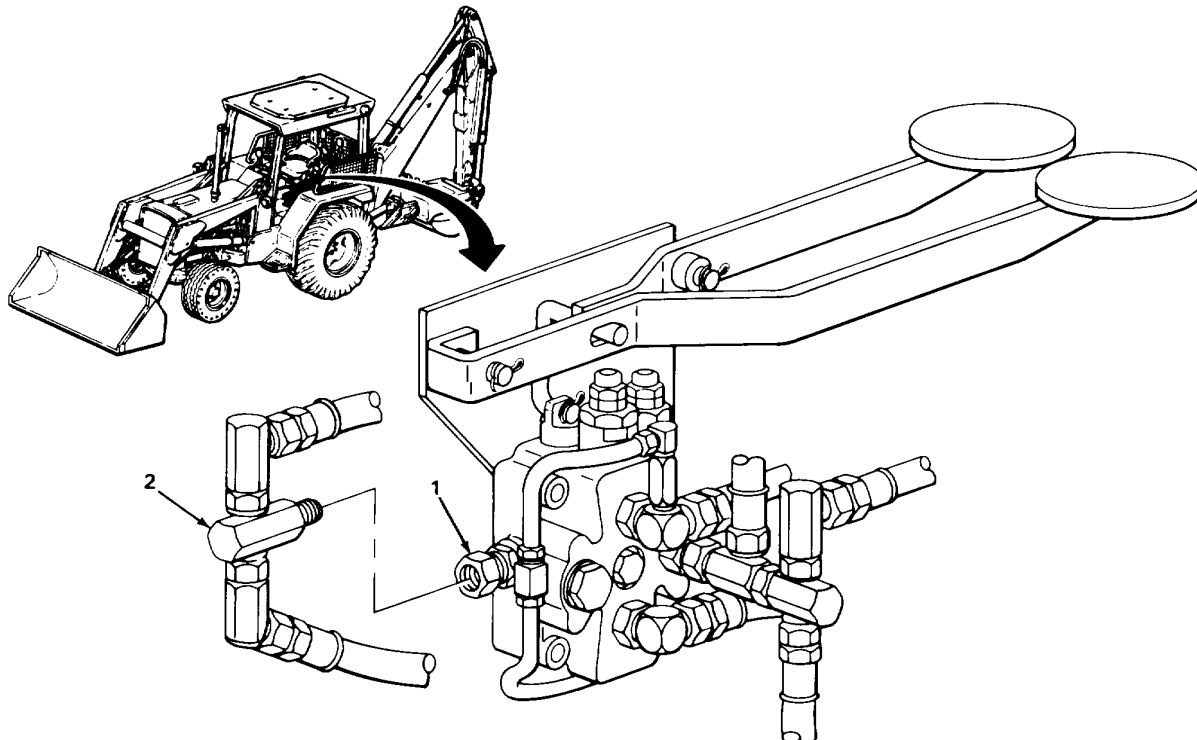

TA243331

JAW DIRECT LINEAR VALVE (SERIAL NUMBERS 319995 THRU 342573 ONLY) - CONTINUED

LOCATION	ITEM	ACTION REMARKS
REMOVAL - CONTINUED		
2. Bulkhead elbow (1)	Hose (2)	<ul style="list-style-type: none"> a. Place drain pan underneath to catch draining fluid. b. Using 7/8-inch open-end wrench, unscrew and take off. c. Plug (page 2-137). d. Tag (page 2-137).
3. Connector (3)	Swivel tee (4) with assembled parts	<ul style="list-style-type: none"> a. Place drain pan underneath to catch draining fluid. b. Using two 1 1/4-inch open-end wrenches, unscrew and take off. c. Plug (page 2-137).
4. Bulkhead elbow (5)	Hose (6)	<ul style="list-style-type: none"> a. Place drain pan underneath to catch draining fluid. b. Using 7/8-inch open-end wrench, unscrew and take off. c. Plug (page 2-137). d. Tag (page 2-137).
5. Link (7) and valve (8)	Cotter pin (9)	<ul style="list-style-type: none"> a. Using long roundnose pliers, bend ends straight and pull out. b. Get rid of.
6. Valve (8) and bracket (10)	Two screws (11), lockwashers (12), and nuts (13)	<ul style="list-style-type: none"> a. Using 9/16-inch, 318-inch drive deep socket, ratchet handle, and 9/16-inch combination box and open-end wrench, unscrew and take apart. Top screw will stay in bracket. b. Get rid of lockwashers (12).

NOTE

Before removing valve, note relative position of hoses and tees.

7. Link (7) and bracket (10)	Valve (8)	<ul style="list-style-type: none"> a. Take off. b. Get rid of drained fluid (page 2-137).
------------------------------	-----------	---

DISASSEMBLY

8. Valve	Jaw control (direct linear) valve tubes and fittings	Remove (page 2-1391).
----------	--	-----------------------

JAW DIRECT LINEAR VALVE (SERIAL NUMBERS 319995 THRU 342573 ONLY) - CONTINUED

LOCATION	ITEM	ACTION	REMARKS
9. Valve (8)	Connector (14) with assembled packing (15)	a. Place valve (8) in machinist's vise with vise jaw caps. b. Using 1 1/2-inch open-end wrench, unscrew and take off.	
10. Connector (14)	Packing (15)	a. Using pocket knife, take off. b. Get rid of.	
11. Valve (8)	Connector (3) with assembled packing (16)	Using 1 1/4-inch open-end wrench, unscrew and take off.	
12. Connector (3)	Packing (16)	a. Using pocket knife, take off. b. Get rid of.	

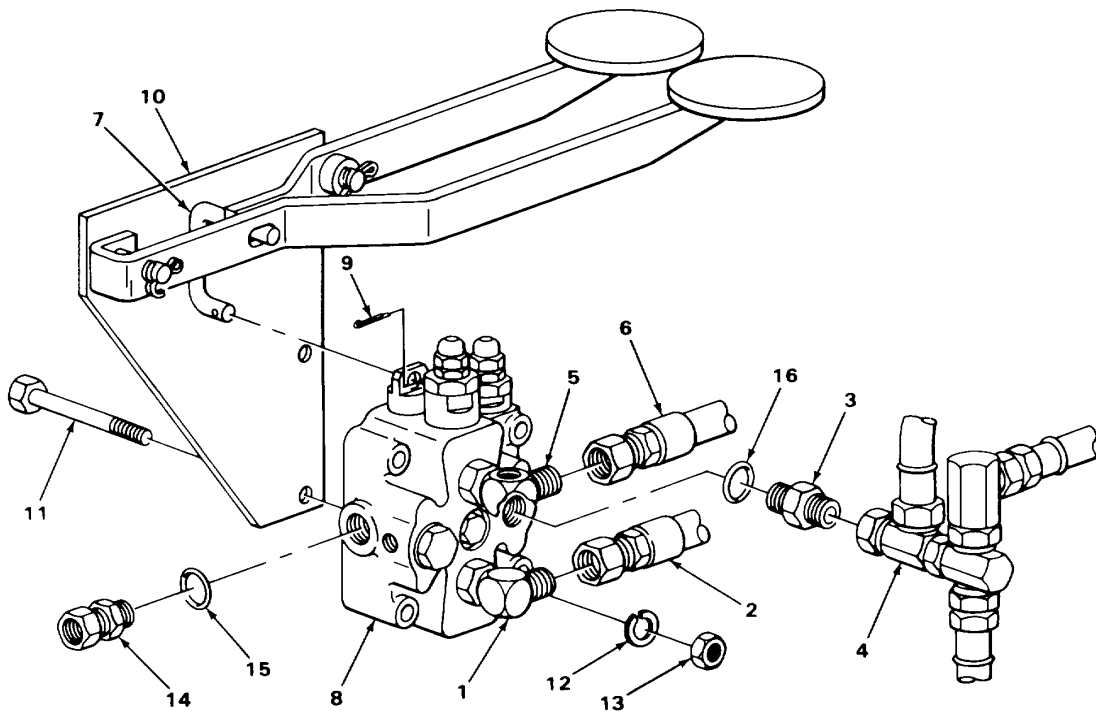

TA243332

JAW DIRECT LINEAR VALVE (SERIAL NUMBERS 319995 THRU 342573 ONLY) - CONTINUED

LOCATION	ITEM	ACTION	REMARKS
DISASSEMBLY - CONTINUED			
13.	Valve (1) and two bulkhead elbows (2 and 3)	Two nuts (4 and 5)	Using 13/16-inch and 7/8-inch open-end wrenches, loosen.
14.	Valve (1)	Two bulkhead elbows (2 and 3) with attached parts	a. Note relative position for proper placement during assembly. b. Using 13/16-inch open-end wrench, unscrew and take out.
15.	Two bulkhead elbows (2 and 3)	Two packings (6 and 7)	a. Using pocket knife, take off. b. Get rid of.
16.	Valve(1)	Plug (8) with assembled packing (9)	a. Using 1 1/2-inch open-end wrench, unscrew and take off. b. Take valve (1) out of machinist's vise with vise jaw caps.
17.	Plug (8)	Packing (9)	a. Using pocket knife, take off. b. Get rid of.

CLEANING**NOTE**

For more information on how to clean parts, go to **General Maintenance Instructions (page 2-137)**.

WARNING

Dry-cleaning solvent P-D-680 is toxic and flammable. Wear protective goggles and gloves and use only in a well ventilated area. Avoid contact with skin, eyes, and clothes and don't breathe vapors. Do not use near open flame or excessive heat. The flashpoint is 100°F to 138°F (38° to 59°C). If you become dizzy while using cleaning solvent, get fresh air immediately and get medical aid. If contact with eyes is made, wash your eyes with water and get medical aid immediately.

18.	Valve (1)		a. Using clean rags dampened with dry-cleaning solvent, wipe clean. b. Using clean, dry rags, wipe dry.
19.	All other metal parts		a. Clean in dry-cleaning solvent. b. Using clean, dry rags, wipe dry.

JAW DIRECT LINEAR VALVE (SERIAL NUMBERS 319995 THRU 342573 ONLY) - CONTINUED

LOCATION	ITEM	ACTION	REMARKS
INSPECTION/REPLACEMENT			
NOTE			
For more information on how to inspect parts, go to General Maintenance Instructions (page 2-137) .			
Replace defective parts as needed.			
20.	All metal parts	Look for cracks and breaks.	
21.	All threaded parts	Look for damaged threads.	
ASSEMBLY			
22. Plug (8)	New packing (9)	Place in position.	
23. Valve (1)	Plug (8) with assembled packing (9)	a. Place valve(1)in machinist's vise with vise jaw caps. b. Screw in and tighten using 1 1/2-inch open-end wrench.	
24. Two bulkhead elbows (2 and 3)	Two nuts (4 and 5)	Screw on all the way.	
25.	Two new packings (6 and 7)	Place in position.	

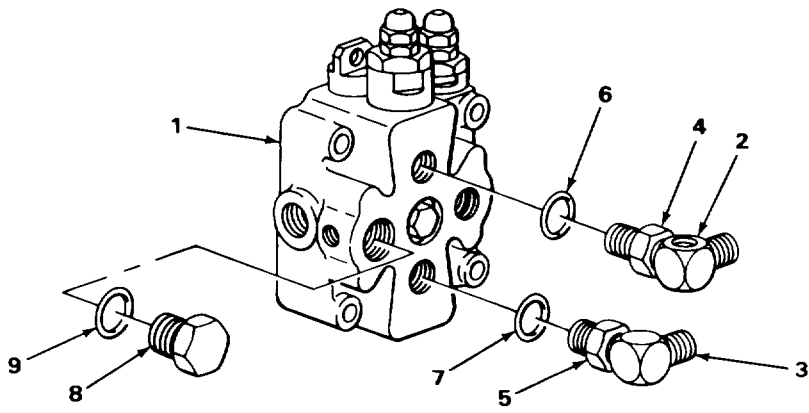

TA243333

JAW DIRECT LINEAR VALVE (SERIAL NUMBERS 319995 THRU 342573 ONLY) - CONTINUED

LOCATION	ITEM	ACTION	REMARKS
ASSEMBLY - CONTINUED			
26.	Valve (1)	Two bulkhead elbows (2 and 3) with attached parts	Screw in and tighten to relative positions noted during disassembly using 13/16-inch open-end wrench.
27.	Valve (1) and two bulkhead elbows (2 and 3)	Two nuts (4 and 5)	Using 13/16-inch and 7/8-inch open-end wrenches, tighten until seated against valve (1).
28.	Connector (6)	New packing (7)	Place in position.
29.	Valve (1)	Connector (6) with assembled packing (7)	Screw in and tighten using 1 1/4-inch open-end wrench.
30.	Connector (8)	New packing (9)	Place in position.
31.	Valve (1)	Connector (8) with assembled packing (9)	a. Screw in and tighten using 1 1/2-inch open-end wrench. b. Take valve (1) out of machinist's vise with vise jaw caps.
32.	Valve	Jaw control (direct linear) valve tubes and fittings	Install (page 2-1391).
INSTALLATION			
NOTE			
Before installing valve, make sure hoses and tees are in same relative position as noted during removal.			
33.	Link (10) and bracket (11)	Valve (1)	a. Aline link (10) with hole in valve plunger. b. Place in position.
34.	Valve (1) and bracket (11)	Two screws (12), new lockwashers (13), and nuts (14)	Screw together and tighten using 9/16-inch, 3/8-inch drive deep socket, ratchet handle, and 9/16-inch combination box and open-end wrench.

JAW DIRECT LINEAR VALVE (SERIAL NUMBERS 319995 THRU 342573 ONLY) - CONTINUED

LOCATION	ITEM	ACTION	REMARKS
35. Link (10) and valve (1)	New cotter pin (15)	a. Place in position. b. Using long roundnose pliers, bend ends back.	
36. Bulkhead elbow (2)	Hose (16)	a. Take off tag. b. Unplug. c. Screw in and tighten using 7/8-inch open-end wrench.	
37. Connector (6)	Swivel tee (17) with assembled parts	a. Unplug. b. Screw on and tighten using 1 1/4-inch open-end wrench.	
38. Bulkhead elbow (3)	Hose (18)	a. Take off tag. b. Unplug. c. Screw on and tighten using 7/8-inch open-end wrench.	

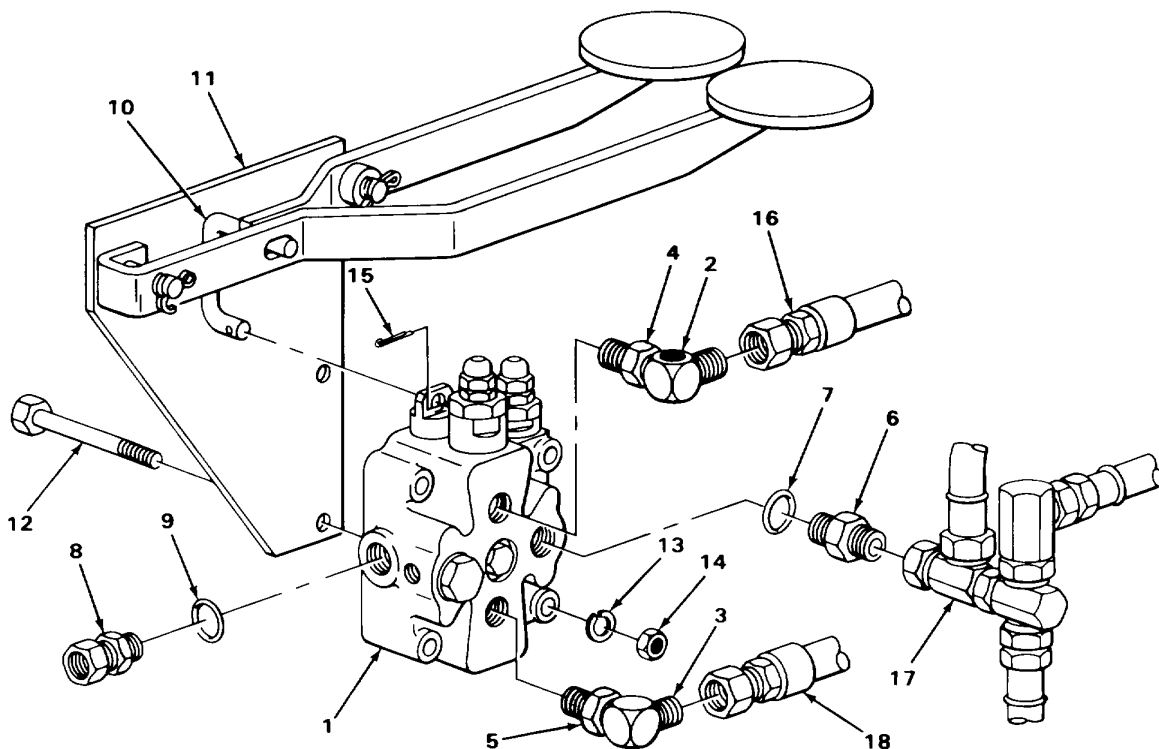

TA243334

JAW DIRECT LINEAR VALVE (SERIAL NUMBERS 319995 THRU 342573 ONLY) - CONTINUED

LOCATION	ITEM	ACTION REMARKS
INSTALLATION - CONTINUED		
39. Connector (1)	Tee (2) with assembled parts	a. Uncap. b. Screw on and tighten using two 1 1/4-inch wrenches.
40. Loader backhoe	Transmission	Check fluid level and add proper amount and grade (TM 5-2420-222-10).
41.	Engine	Start and run at high idle (TM 5-2420-222-10).
42.	Jaw direct linear valve	a. Operate jaw cylinder (TM 5-2420-222-10) and check for leaks. b. If leaking at any connection, tighten using 7/8-inch open-end wrench or 1 1/4-inch and 1 1/2-inch open-end wrenches or 13/16-inch open-end wrench or two 1 1/4-inch open-end wrenches, or 1 1/2-inch open-end wrench. c. If leaking does not stop, shut down (TM 5-2420-222-10) and replace leaking connection packing, fitting, or valve as outlined in this task. d. If found leaking, repeat steps 40 thru 42.
43.	Engine	If still running, shut down (TM 5-2420-222-10).

JAW DIRECT LINEAR VALVE (SERIAL NUMBERS 319995 THRU 342573 ONLY) - CONTINUED

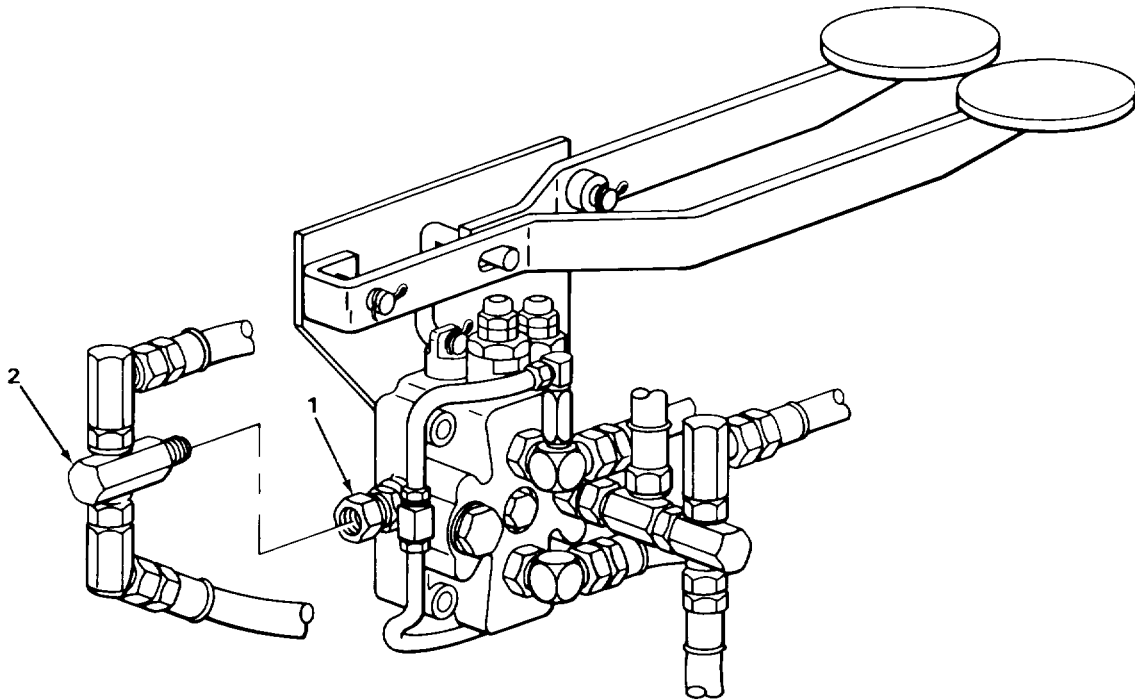

NOTE

FOLLOW-ON MAINTENANCE:

1. Install right rear platform (page 2-1110)
2. Install left rear platform (page 2-1114).

TASK ENDS HERE

TA243335

BACKHOE CONTROL VALVE

This task covers:

- a. Removal (page 2-1260)
 - b. Disassembly (page 2-1262)
 - c. Cleaning (page 2-1264)
 - d. Inspection/Replacement (page 2-1264)
 - e. Assembly (page 2-1265)
 - f. Installation (page 2-1266)
-

INITIAL SETUP

Tools

- Handle, ratchet, 1/2-inch drive
- Knife, pocket
- Pan, drain
- Socket, 1/2-inch drive, 3/4-inch
- Wrench, open-end, 1 1/16-inch
- Wrench, open-end, 3/4-inch
- Wrench, open-end, 7/8-inch
- Wrench, open-end, 15/16-inch
- Wrench, open-end, 1-inch
(two required)
- Wrench, open-end, 1 1/8-inch
- Wrench, open-end, 1 1/4-inch
- Wrench, open-end, 1 3/4-inch

Materials/Parts - Continued

- Packing, union adapter-to-valve
(two required)
- Packing, union adapter-to-valve
(four required)
- Packing, union adapter-to-valve
(two required)
- Rags, wiping (item 21, Appendix C)
- Solvent, dry-cleaning (item 28, Appendix C)
- Tags, marking (item 30, Appendix C)

Personnel Required

Two

Materials/Parts

- Lockwasher, valve screw
(three required)
- Packing, adapter-to-valve
(six required)

Equipment Condition

1. Hydraulic system pressure released
(page 2-1191)
 2. Backhoe control valve levers and linkage removed (page 2-1189)
-

LOCATION	ITEM	ACTION	REMARKS
----------	------	--------	---------

REMOVAL

WARNING

Do not attempt to disconnect hydraulic lines and fittings while engine is running or before hydraulic system pressure has been released. When engine is running, hydraulic system is under pressure. Hydraulic system pressure should be 0 psi (0 kPa) before lines are disconnected. A line or fitting disconnected under pressure will blow off with a lot of force and could cause serious injury to personnel.

Be careful when draining hot fluids. Wear gloves to protect your hands from hot parts and fluids or severe burns could result.

BACKHOE CONTROL VALVE - CONTINUED

LOCATION	ITEM	ACTION REMARKS
1. Two union adapters (1)	Two hoses (2)	a. Place drain pan underneath to catch draining fluid. b. Using 11/16-inch and 7/8-inch open-end wrenches, unscrew and take out. c. Tag (page 2-137). d. Cap (page 2-137).
2. Six straight adapters (3)	Six hoses (4)	a. Using 7/8-inch and 1-inch open-end wrenches, unscrew and take out. b. Tag (page 2-137). c. Cap (page 2-137).
3. Two union adapters (5 and 6)	Four hoses (7 thru 10)	a. Using 11/16-inch, 3/4-inch, and 7/8-inch open-end wrenches, unscrew and take out. b. Tag (page 2-137). c. Cap (page 2-137).

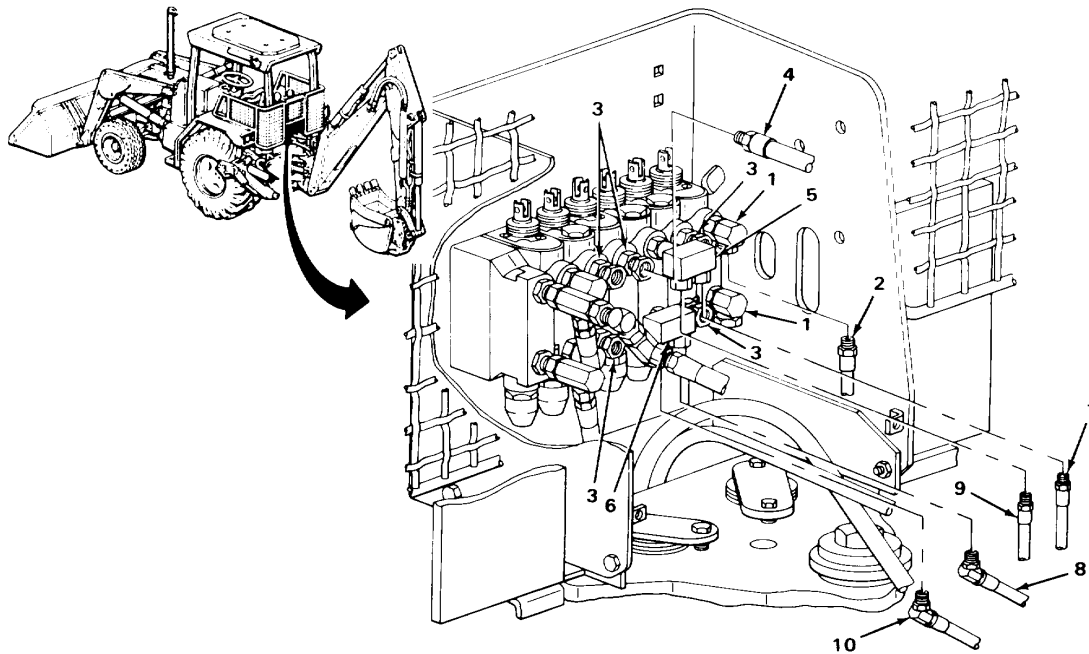

TA243336

BACKHOE CONTROL VALVE - CONTINUED

LOCATION	ITEM	ACTION REMARKS
REMOVAL - CONTINUED		
4. Special adapter (1)	Hose (2)	a. Using 1 1/8-inch and 1 1/4-inch open-end wrenches, unscrew and take out. b. Tag (page 2-137). c. Cap (page 2-137).
5. Two union adapters (3)	Two special adapters (1 and 4) with assembled parts	a. Using 1 1/4-inch and 1 3/8-inch open-end wrenches, unscrew and take out. b. Tag (page 2-137). c. Cap (page 2-137).
6. Two union adapters (5)	Two hoses (6)	a. Using 11/16-inch and 7/8-inch open-end wrenches, unscrew and take out. b. Tag (page 2-137). c. Cap (page 2-137).
7. Valve assembly (7) and valve box (8)	Three screws (9) and lockwashers (10)	a. Have assistant support valve assembly (7). b. Using 3/4-inch, 1/2-inch drive socket and ratchet handle, unscrew and take out. c. Get rid of lockwashers (10).
8. Valve box (8)	Valve assembly (7)	a. Have assistant take off. b. Allow fluid to drain into drain pan. c. Get rid of drained fluid (page 2-137).
DISASSEMBLY		
9. Valve assembly (7)	Six straight adapters (11) with assembled packings (12)	Using 1-inch open-end wrench, unscrew and take out.
10. Six straight adapters (11)	Six packings (12)	a. Using pocket knife, take off. b. Get rid of.
11. Valve assembly (7)	Two union adapters (3) with assembled packings (13)	Using 1 1/4-inch open-end wrench, unscrew and take out.
12. Two union adapters (3)	Two packings (13)	a. Using pocket knife, take off. b. Get rid of.

BACKHOE CONTROL VALVE - CONTINUED

LOCATION	ITEM	ACTION	REMARKS
13. Two union adapters (5), two union adapters (14), and valve assembly (7)	Two nuts (15) and two nuts (16)	Using 1-inch open-end wrench, loosen.	
14. Valve assembly (7)	Two union adapters (5) and two union adapters (14) with assembled parts	a. Note relative position for proper placement during assembly. b. Using 1-inch open-end wrench, unscrew and take out.	
15. Two union adapters (4) and two union adapters (14)	Two packings (17) and two packing (18)	a. Using pocket knife, take off. b. Get rid of.	

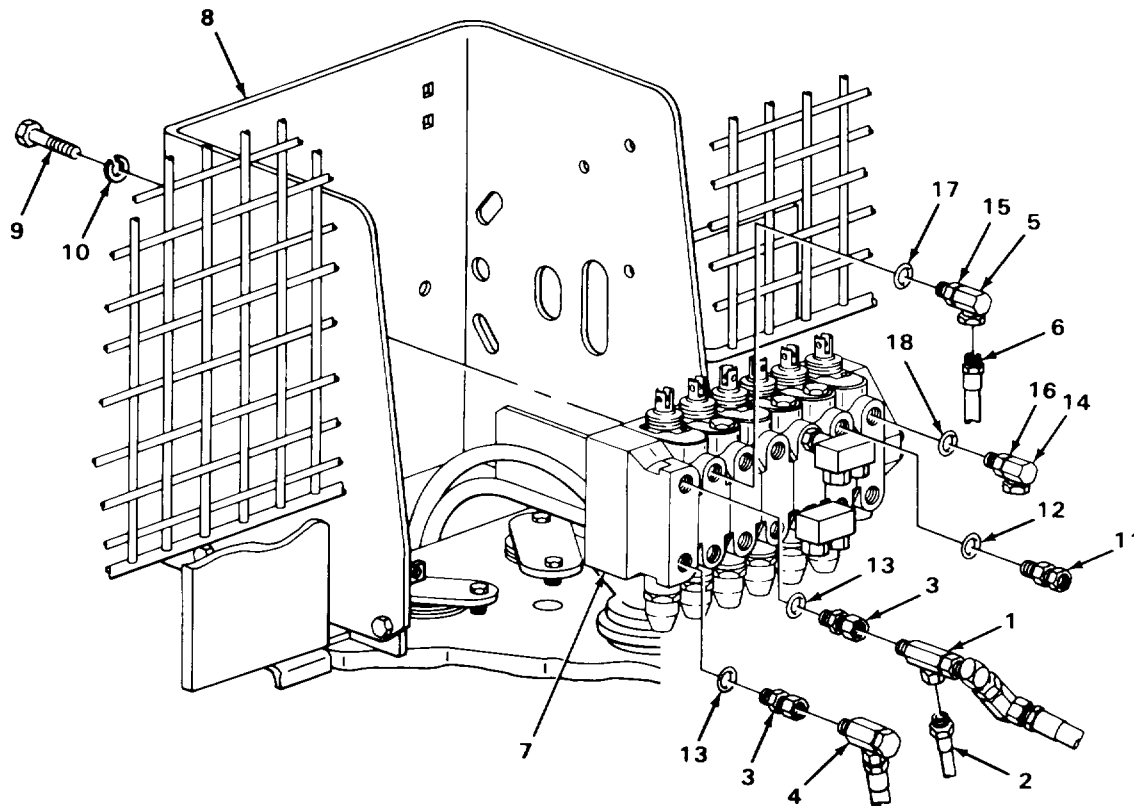

TA243337

BACKHOE CONTROL VALVE - CONTINUED

LOCATION	ITEM	ACTION	REMARKS
DISASSEMBLY - CONTINUED			
16.	Two union adapters (1 and 2) and valve assembly (3)	Two nuts (4 and 5)	Using two 1-inch open-end wrenches, loosen.
17.	Valve assembly (3)	Two union adapters (1 and 2) with assembled parts	a. Note relative position for proper placement during assembly. b. Using 1-inch open-end wrench, unscrew and take off.
18.	Two union adapters (1 and 2)	Two packings (6 and 7)	a. Using pocket knife, take off. b. Get rid of.

CLEANING

NOTE

For more information on how to clean parts, go to **General Maintenance Instructions (page 2-137)**.

WARNING

Dry-cleaning solvent P-D-680 is toxic and flammable. Wear protective goggles and gloves and use only in a well ventilated area. Avoid contact with skin, eyes, and clothes and don't breathe vapors. Do not use near open flame or excessive heat. The flashpoint is 100°F to 138°F (38° to 59°C). If you become dizzy while using cleaning solvent, get fresh air immediately and get medical aid. If contact with eyes is made, wash your eyes with water and get medical aid immediately.

19.	Valve assembly (3)	a. Using clean rags dampened with dry-cleaning solvent, wipe clean. b. Using clean, dry rags, wipe dry.
20.	All other metal parts	a. Clean in dry-cleaning solvent. b. Using clean, dry rags, wipe dry.

INSPECTION/REPLACEMENT

NOTE

For more information on how to inspect parts, go to **General Maintenance Instructions (page 2-137)**.

Replace defective parts as needed.

BACKHOE CONTROL VALVE - CONTINUED

LOCATION	ITEM	ACTION REMARKS
21.	All metal parts	a. Look for cracks, bends, and breaks. b. Look for damaged threads.
ASSEMBLY		
22. Two union adapters (1 and 2)	Two nuts (4 and 5)	Screw on all the way.
23.	Two new packings (6 and 7)	Place in position.
24. Valve assembly (3)	Two union adapters (1 and 2) with assembled parts	Screw in and tighten to same relative positions noted during disassembly using 1-inch open-end wrench.
25. Two union adapters (1 and 2) and valve assembly (3)	Two nuts (4 and 5)	Using two 1-inch open-end wrenches, tighten until seated against valve assembly (3).
26. Two union adapters (8) and two union adapters (9)	Two nuts (10) and two nuts (11)	Screw on all the way.

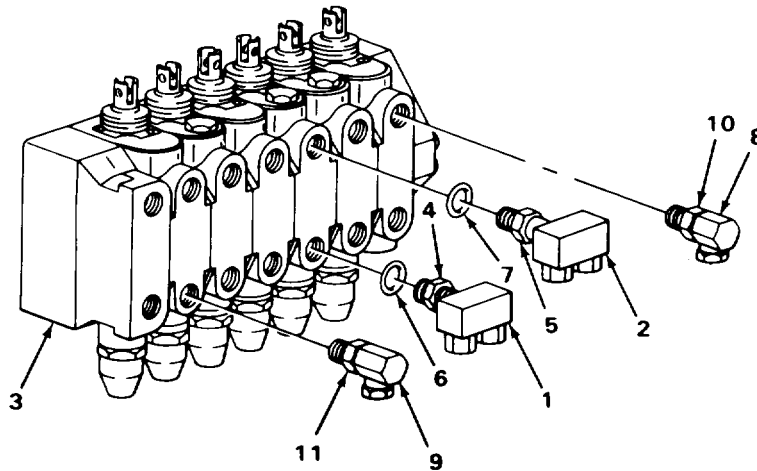

TA243338

BACKHOE CONTROL VALVE - CONTINUED

LOCATION	ITEM	ACTION REMARKS
27. Two union adapters (1) and two union adapters (2)	Two new packings (3) and two new packings (4)	Place in position.
28. Valve assembly (5)	Two union adapters (1) and two union adapters (2) with assembled parts	Screw in and tighten to same relative positions noted during disassembly using 1-inch open-end wrench.
29. Two union adapters (1), two union adapters (2), and valve assembly (5)	Two nuts (6) and two nuts (7) assembly (5).	Using two 1-inch open-end wrenches, tighten until seated against valve
30. Two union adapters (8)	Two new packings (9)	Place in position.
31. Valve assembly (5)	Two union adapters (8) with assembled packings (9)	Screw in and tighten using 1 1/4-inch open-end wrench.
32. Six straight adapters (10)	Six new packings (11)	Place in position.
33. Valve assembly (5)	Six straight adapters (1) with assembled packings (11)	Screw in and tighten using 1-inch open-end wrench.
INSTALLATION		
34. Valve box (12)	Valve assembly (5)	Have assistant place in position.
35. Valve assembly (5) and valve box (12)	Three screws (13) and new lock-washers (14)	<ol style="list-style-type: none"> a. Have assistant support valve assembly (5). b. Screw in and tighten using 3/4-inch, 1/2-inch drive socket, and ratchet handle.
36. Two union adapters (1)	Two hoses (15)	<ol style="list-style-type: none"> a. Take off tags. b. Uncap. c. Screw in and tighten using 11/16-inch and 7/8-inch open-end wrenches.

BACKHOE CONTROL VALVE - CONTINUED

LOCATION	ITEM	ACTION	REMARKS
37. Two union adapters (8)	Two special adapters (16 and 17) with assembled parts	a. Take off tags. b. Uncap. c. Screw in and tighten using 1 1/4-inch and 1 3/8-inch open-end wrenches.	
38. Special adapters (17)	Hose (18)	a. Take off tag. b. Uncap. c. Screw on and tighten using 1 1/8-inch and 1 1/4-inch open-end wrenches.	
39. Two union adapters (19 and 20)	Four hoses (21 thru 24)	a. Take off tags. b. Uncap. c. Screw in and tighten using 11/16-inch 3/4-inch, and 7/8-inch open-end wrenches.	

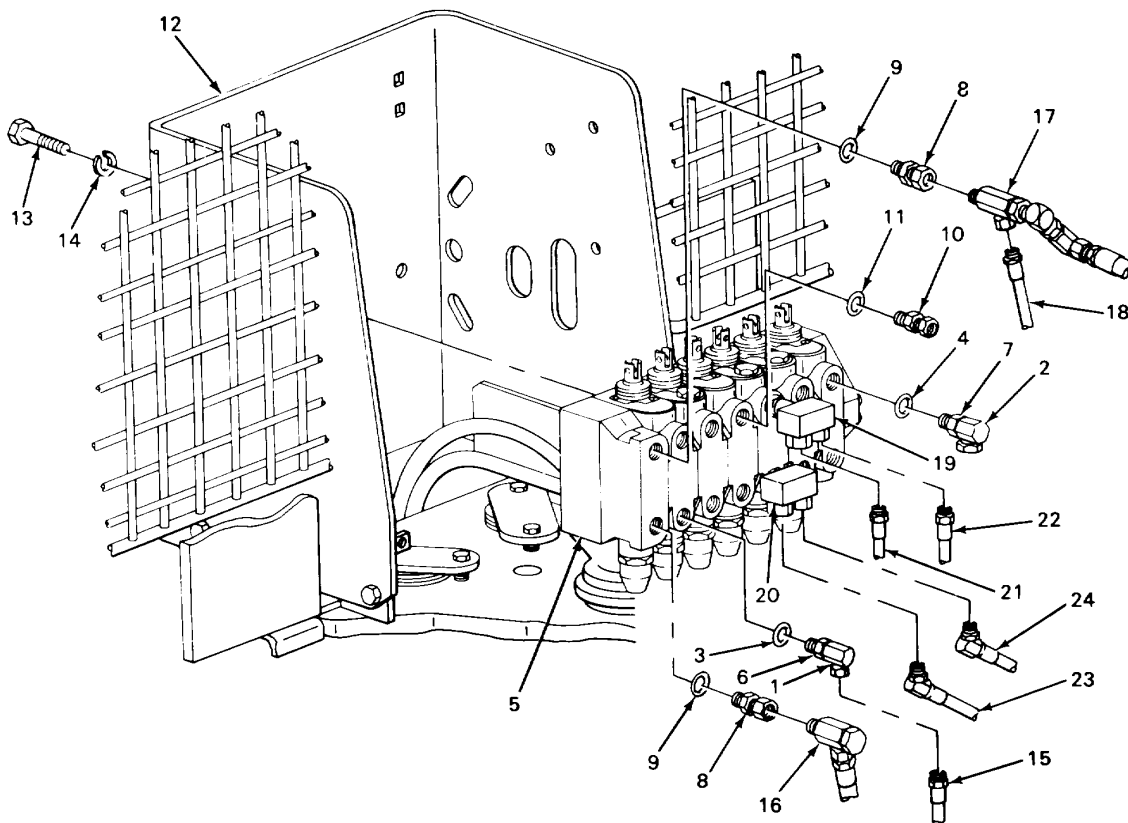

TA243339

BACKHOE CONTROL VALVE - CONTINUED

LOCATION	ITEM	ACTION	REMARKS
INSTALLATION - CONTINUED			
40.	Six straight adapters (1)	Six hoses (2)	<ol style="list-style-type: none"> Take off tags. Uncap. Screw in and tighten using 7/8-inch and 1-inch open-end wrenches.
41.	Two union adapters (3)	Two hoses (4)	<ol style="list-style-type: none"> Take off tags. Uncap. Screw in and tighten using 11/16-inch and 7/8-inch open-end wrenches.
42.	Loader backhoe	Backhoe control valve levers and linkage	<p>Install (page 2-1189).</p> <p>Do not install backhoe valve box cover at this time.</p>
43.		Transmission	Check fluid level and add proper amount and grade (TM 5-2420-222-10).
44.		Engine	Start and run at high idle (TM 5-2420-222-10).
45.		Backhoe control valve	<ol style="list-style-type: none"> Operate backhoe (TM 5-2420-222-10) and check for leaks. If leaking at any connection, tighten using 11/16-inch, 3/4-inch, 7/8-inch 1-inch, 1 1/8-inch, 1 1/4-inch and 1 3/8-inch open-end wrenches. If leaking does not stop, shut down engine (TM 5-2420-222-10) and replace leaking connection packing, or component as outlined in this task. If found leaking, repeat steps 43 thru 45.
46.	Loader backhoe	Engine	If still running, shut down (TM 5-2420-222-10).
47.	Two four way levers (5) and handle mounts (6)	Two nuts (7)	Using 15/16-inch open-end wrench, loosen.
48.	Two handle mounts (6)	Two four way levers (5)	Noting position for proper placement during installation, unscrew and take out.

BACKHOE CONTROL VALVE - CONTINUED

LOCATION	ITEM	ACTION	REMARKS
49. Two control levers (8) and handle mounts (9)	Two nuts (10)	Using 3/4-inch open-end wrench, loosen.	
50. Two handle mounts (9)	Two control levers (5)	Noting position for proper placement during installation, unscrew and take out.	

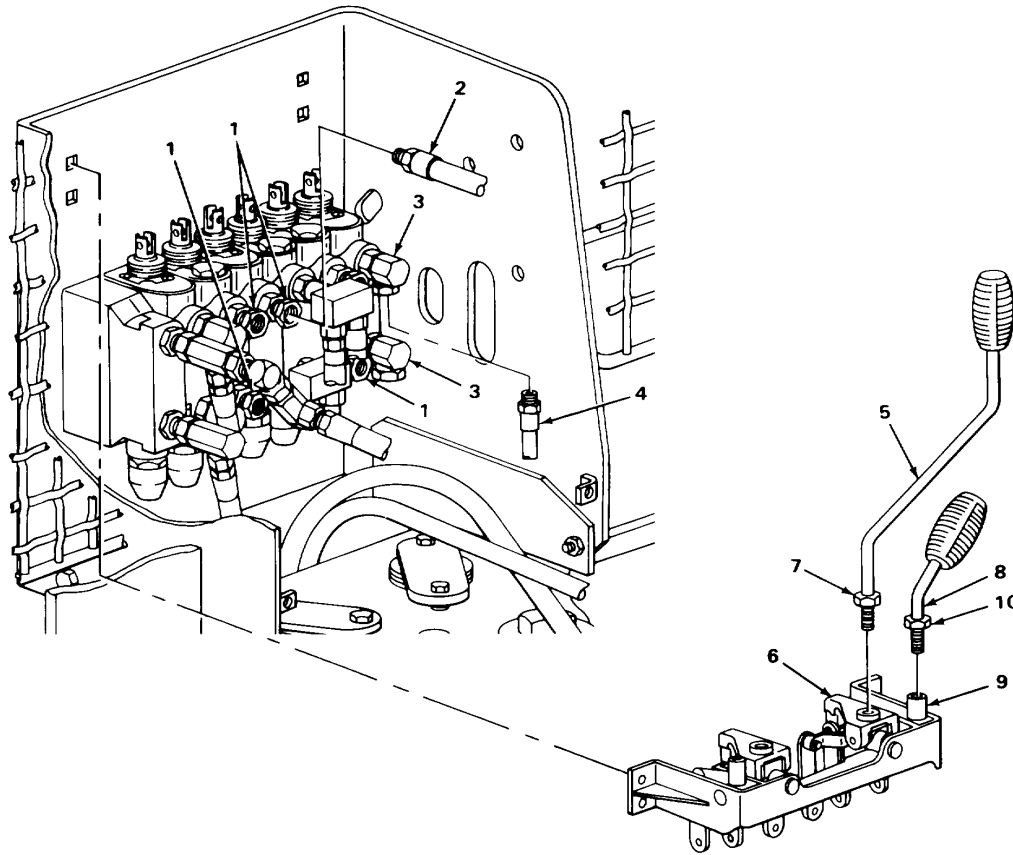

NOTE

FOLLOW-ON MAINTENANCE: Install backhoe valve box cover (page 2-1157).

TASK ENDS HERE

TA243340

MANIFOLD BLOCK

JAW DIRECT LINEAR VALVE (SERIAL NUMBERS 319995 THRU 342573 ONLY)

This task covers:

- a. Removal (page 2-1271)
 - b. Disassembly (page 2-1274)
 - c. Cleaning (page 2-1276)
 - d. Inspection/Replacement (page 2-1276)
 - e. Assembly (page 2-1276)
 - f. Installation (page 2-1278)
-

INITIAL SETUP

Tools

- Handle, ratchet, 1/2-inch drive
- Key, socket-head screw, 5/16-inch
- Knife, pocket
- Pan, drain
- Socket, 1/2-inch drive, 9/16-inch
- Socket, 1/2-inch drive, 3/4-inch
- Vise, machinist's
- Wrench, box, 3/4-inch
- Wrench, open-end, 9/16-inch
- Wrench, open-end, 7/8-inch
- Wrench, open-end, 1-inch
(two required)

NOTE

The following tool only applies to loader backhoes with Serial Numbers 319995 thru 342573

- Wrench, open-end, 3/4-inch

Materials/Parts

- Nut, special (two required)
(two required)
- Packing, straight adapter-to-manifold block (eight required)
- Packing, union adapter-to-manifold block (four required)
- Rags, wiping (item 21, Appendix C)
- Solvent, dry-cleaning
(item 28, Appendix C)
- Tags, marking (item 30, Appendix C)

Materials/Parts - Continued

NOTE

The following part only applies to loader backhoes with Serial Numbers 235786 thru 235999.

- Lockwasher, manifold block screw
(two required)

NOTE

The following parts only apply to loader backhoes with Serial Numbers 319995 thru 342573.

- Lockwasher, bracket screw (two required)
- Lockwasher, manifold block screw
(two required)

Personnel Required

One

Equipment Condition

- Hydraulic system pressure released
(page 2-1191)

MANIFOLD BLOCK - CONTINUED

LOCATION	ITEM	ACTION	REMARKS
----------	------	--------	---------

REMOVAL

WARNING

Do not attempt to disconnect hydraulic lines and fittings while engine is running or before hydraulic system pressure has been released. When engine is running, hydraulic system is under pressure. Hydraulic system pressure should be 0 psi (0 kPa) before lines are disconnected. A line or fitting disconnected under pressure will blow off with a lot of force and could cause serious injury to personnel.

Be careful when draining hot fluids. Wear gloves to protect your hands from hot parts and fluids or severe burns could result.

- | | | |
|---------------------------|---------------------|---|
| 1. Two union adapters (1) | Two hoses (2 and 3) | <ul style="list-style-type: none"> a. Place drain pan underneath to catch draining fluid. b. Using 7/8-inch and 1-inch open-end wrenches, unscrew and take out. c. Cap (page 2-137). d. Tag (page 2-137). |
|---------------------------|---------------------|---|

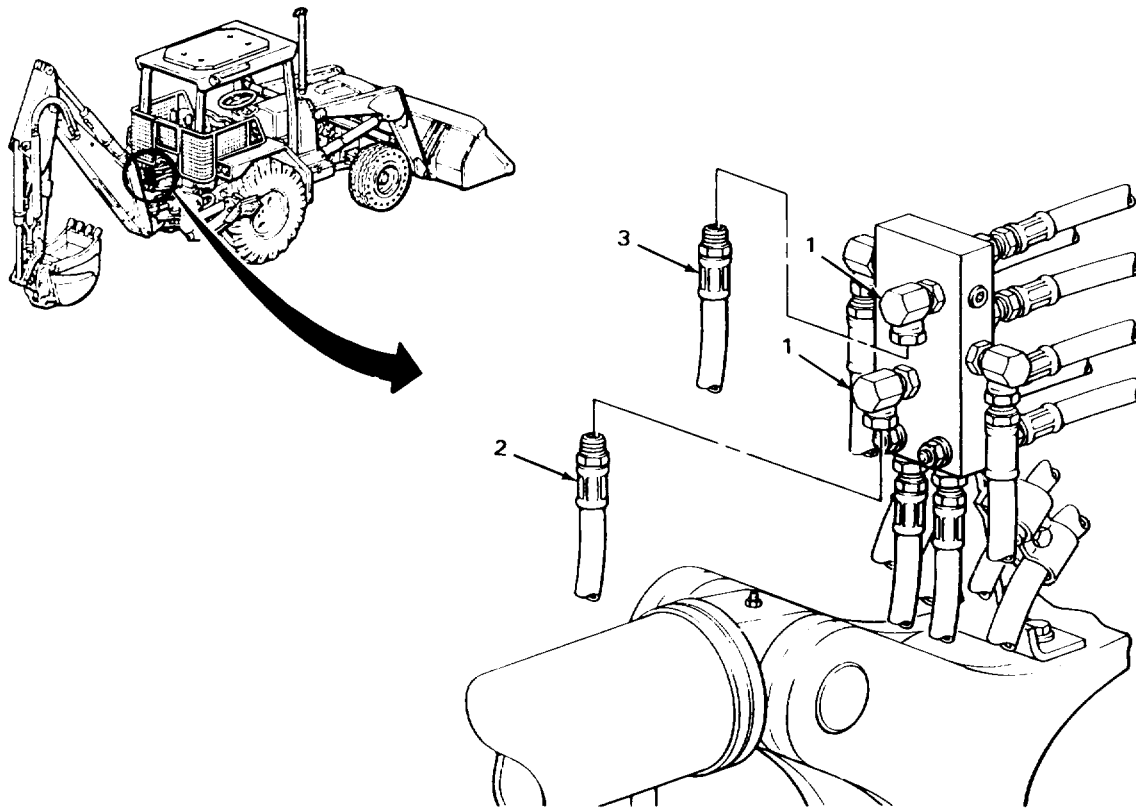

TA243341

MANIFOLD BLOCK - CONTINUED

LOCATION	ITEM	ACTION REMARKS
REMOVAL - CONTINUED		
2. Eight straight adapters (1)	Six hoses (2) and two hoses (3)	a. Using 7/8-inch and 1-inch open-end wrenches, unscrew and take out. b. Cap (page 2-137). c. Tag (page 2-137).
3. Two union adapters (4)	Two hoses (5 and 6)	a. Using two 1-inch open-end wrenches, unscrew and take out. b. Cap (page 2-137). c. Tag (page 2-137).

NOTE

On loader backhoes with Serial Numbers 235786 thru 235999, manifold block is welded assembly which includes bracket. On loader backhoes with Serial Numbers 319995 thru 342573, manifold block and bracket are separate parts.

4. Clamp (7) and manifold block (8) or manifold bracket (9)	Screw (10) and special nut (11)	a. Using 9/16-inch, 1/2-inch drive socket, ratchet handle, and 9/16-inch open-end wrench, unscrew and take apart. b. Get rid of special nut (11).
5. Hose (12), isolator (13), and manifold block (8) or manifold bracket (9)	Clamp (7)	Take off.
6. Clamp (14) and manifold block (8) or manifold bracket (9)	Screw (15) and special nut (16)	a. Using 9/16-inch, 1/2-inch drive socket, ratchet handle, and 9/16-inch open-end wrench, unscrew and take apart. b. Get rid of special nut (16).
7. Two hoses (17 and 18), isolator (19), and manifold block (8) or manifold bracket (9)	Clamp (14)	Take off.

MANIFOLD BLOCK - CONTINUED

LOCATION	ITEM	ACTION	REMARKS
8. Backhoe frame (20) and manifold block (8) or manifold bracket (9)	Two screws (21), washers (22), and lockwashers (23)	a. Using 3/4-inch box wrench, unscrew and take out. b. Get rid of lockwashers (23).	

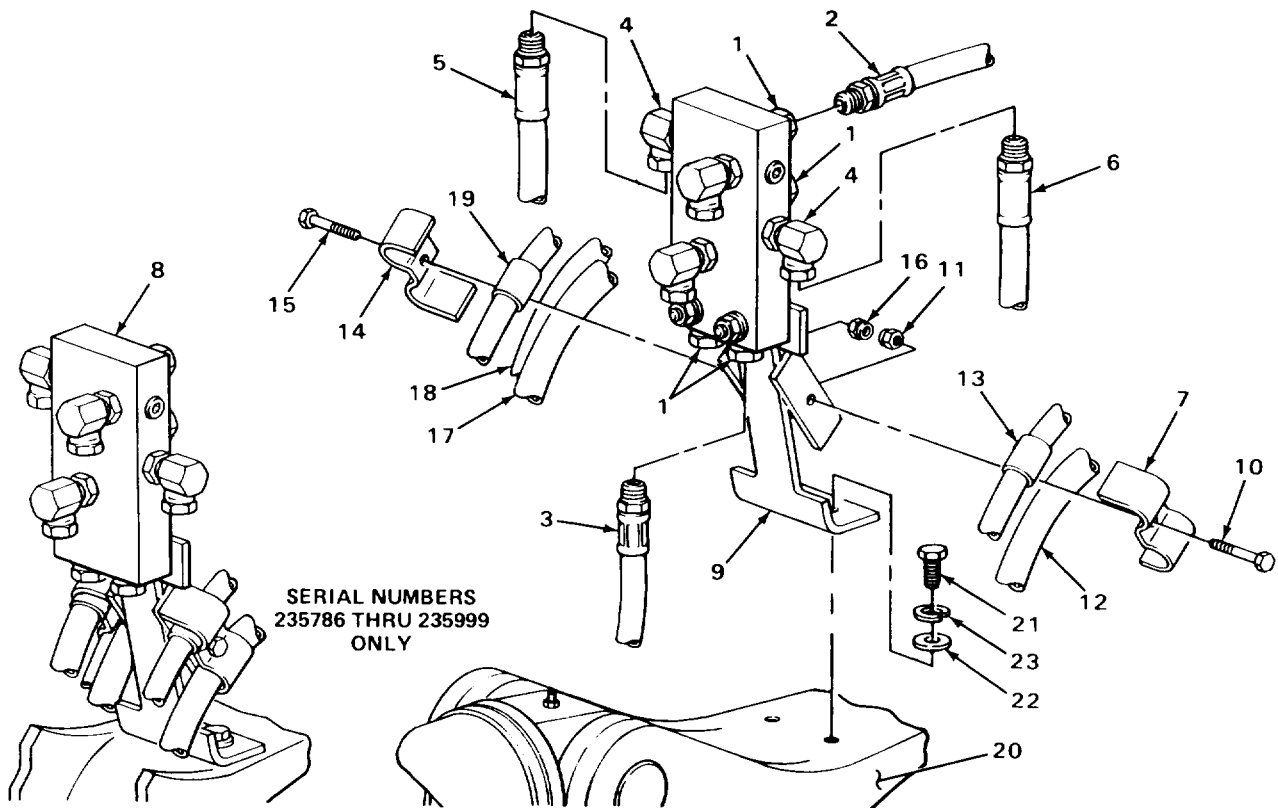

TA243342

MANIFOLD BLOCK - CONTINUED

LOCATION	ITEM	ACTION	REMARKS
REMOVAL - CONTINUED			
9.	Backhoe frame (1), two isolators (2 and 3), and three hoses (4, 5, and 6)	Manifold block (7) or manifold bracket (8) with assembled parts	<ul style="list-style-type: none"> a. Take off. b. Allow fluid to drain into drain pan. c. Get rid of drained fluid (page 2-137).

DISASSEMBLY

NOTE

On loader backhoes with Serial Numbers 235786 thru 235999, manifold block is welded assembly which includes bracket. On loader backhoes with Serial Numbers 319995 thru 342573, manifold block and manifold bracket are separate parts. Both manifold blocks are disassembled in same way except as noted.

10.	Manifold block (7 or 9)	Eight straight adapters (10) with assembled packings (11)	<ul style="list-style-type: none"> a. Place manifold block (7 or 9) in machinist's vise. b. Using 7/8-inch open-end wrench, unscrew and take out.
11.	Eight straight adapters (10)	Eight packings (11)	<ul style="list-style-type: none"> a. Using pocket knife, take off. b. Get rid of.
12.	Two union adapters (12), two union adapters (13), and manifold block (7 or 9)	Two nuts (14) and two nuts (15)	Using 7/8-inch and 1-inch open-end wrenches, loosen.
13.	Manifold block (7 or 9)	Two union adapters (12) and two union adapters (13) with assembled parts	<ul style="list-style-type: none"> a. Note relative positions for proper placement during assembly. b. Using 1-inch open-end wrench, unscrew and take out.
14.	Two union adapters (12) and two union adapters (13)	Two packings (16) and two packings (17)	<ul style="list-style-type: none"> a. Using pocket knife, take off. b. Get rid of.

MANIFOLD BLOCK - CONTINUED

LOCATION	ITEM	ACTION	REMARKS
----------	------	--------	---------

NOTE

Steps 15 and 16 only apply to loader backhoes with Serial Numbers 31995 thru 342573.

15. Manifold block (9) and manifold bracket (8)	Two screws (18), lockwashers (19), and nuts (20)	a. Using 3/4-inch, 1/2-inch drive socket, ratchet handle, and 3/4-inch box wrench, unscrew and take apart. b. Get rid of lockwashers (19).
16. Manifold block (9)	Manifold bracket (8)	Take off.
17. Manifold block (7 or 9)	Two pipe plugs (21)	a. Using 5/16-inch socket-head screw key, unscrew and take out. b. Take manifold block (7 or 9) out of machinist's vise.

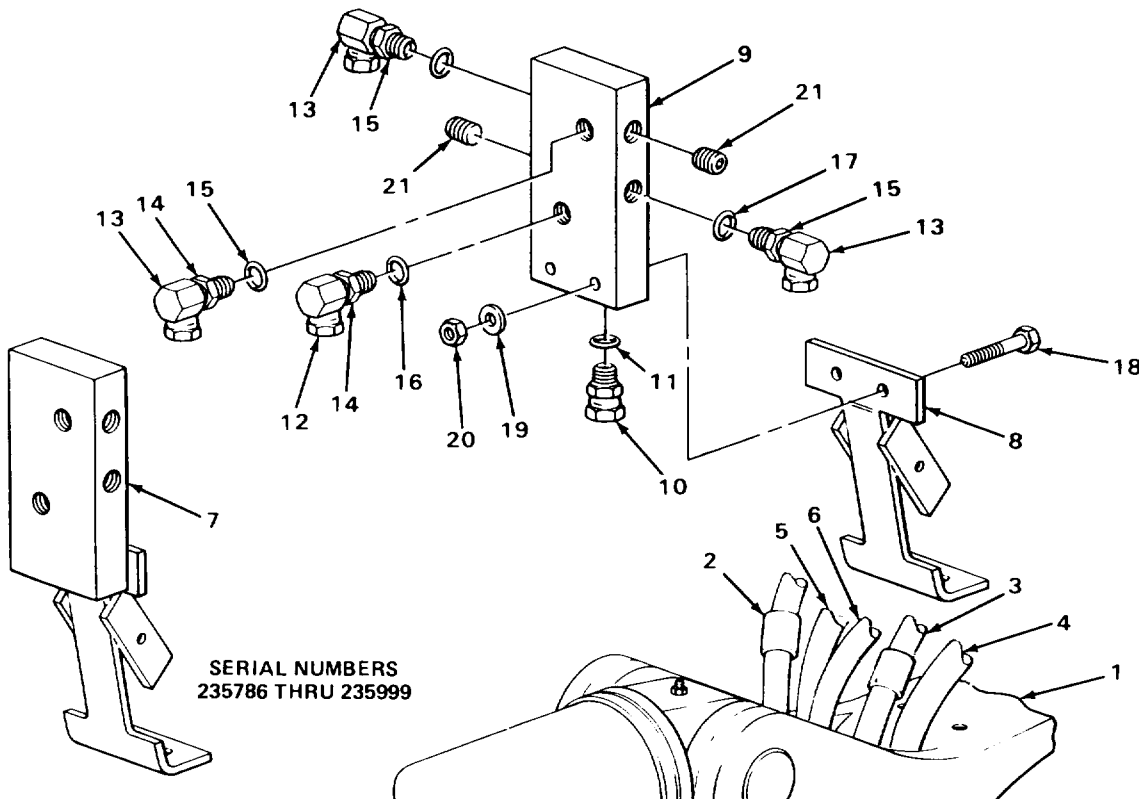

TA243343

MANIFOLD BLOCK - CONTINUED

LOCATION	ITEM	ACTION	REMARKS
CLEANING			
NOTE			
For more information on how to clean parts, go to General Maintenance Instructions (page 2-137).			
<u>WARNING</u>			
Drycleaning solvent P-D-680 is toxic and flammable. Wear protective goggles and gloves and use only in a well ventilated area. Avoid contact with skin, eyes, and clothes and don't breathe vapors. Do not use near open flame or excessive heat. The flashpoint is 100°F to 138°F (38° to 59°C). If you become dizzy while using cleaning solvent, get fresh air immediately and get medical aid. If contact with eyes is made, wash your eyes with water and get medical aid immediately.			
18.	All metal parts	a. Clean in drycleaning solvent. b. Using clean, dry rags, wipe dry.	
INSPECTION/REPLACEMENT			
NOTE			
For more information on how to inspect parts, go to General Maintenance Instructions (page 2-137).			
Replace defective parts as needed.			
19.	All metal parts	Look for cracks, breaks, and abnormal bends.	
20.	All threaded parts	Look for damaged threads.	
ASSEMBLY			
NOTE			
On loader backhoes with Serial Numbers 235786 thru 235999, manifold block is welded assembly which includes bracket. On loader backhoes with Serial Numbers 319995 thru 342573, manifold block and manifold bracket are separate parts. Both manifold blocks are assembled in same way except as noted.			
21. Manifold block (1 or 2)	Two pipe plugs (3)	a. Place manifold block in machinist's vise. b. Screw in and tighten using 5/16-inch socket-head screw key.	

MANIFOLD BLOCK - CONTINUED

LOCATION	ITEM	ACTION	REMARKS
----------	------	--------	---------

NOTE

Steps 22 and 23 only apply to loader backhoes with Serial Numbers 319995 thru 342573.

22. Manifold block (2)	Manifold bracket (4)	Place in position.	
23. Manifold block (2) and manifold bracket (4)	Two screws (5), new lockwashers (6), and nuts (7)	Screw together and tighten using 3/4-inch, 1/2-inch drive socket, ratchet handle, and 3/4-inch box wrench.	
24. Two union adapters (8) and two union adapters (9)	Two nuts (10) and two nuts (11)	Screw on all the way.	
25. Two new packings (12) and two new packings (13)	Place in position.		

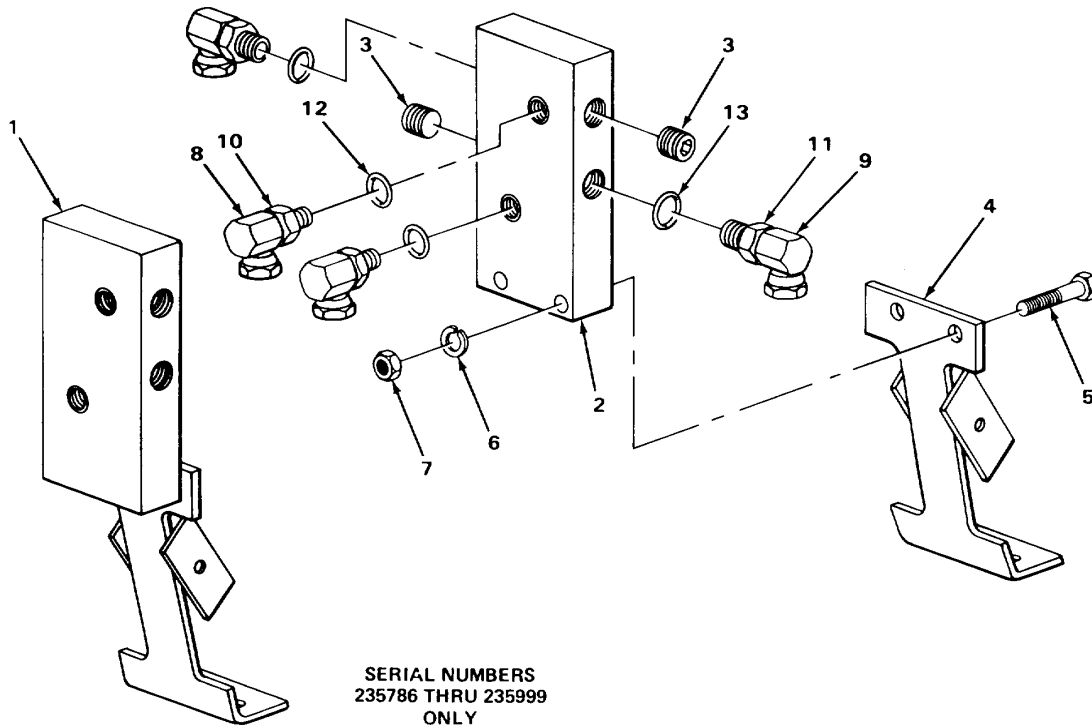

TA243344

MANIFOLD BLOCK - CONTINUED

LOCATION	ITEM	ACTION REMARKS
ASSEMBLY - CONTINUED		
26. Manifold block (1 or 2)	Two union adapters (3) and two union adapters (4) with assembled parts	Screw in and tighten to same relative position noted during disassembly using 1-inch open-end wrench.
27. Two union adapters (3), two union adapters (4) and manifold block (1 or 2)	Two nuts (5) and two nuts (6)	Using 5/8-inch and 1-inch open-end wrenches, tighten until seated against manifold block (1 or 2).
28. Eight straight adapters (7)	Eight new packings (8)	Place in position.
29. Manifold block (1 or 2)	Eight straight adapters (7) with assembled packings (8)	a. Screw in and tighten using 7/8-inch open-end wrench. b. Take manifold block (1 or 2) out of machinist's vise.

INSTALLATION

NOTE

On loader backhoes with Serial Numbers 235786 thru 235999, manifold block is welded assembly which includes bracket. On loader backhoes with Serial Numbers 319995 thru 342573, manifold block and manifold bracket are separate parts.

30. Backhoe frame (9), two isolators (10 and 11), and three hoses (12, 13, and 14)	Manifold block (1) or manifold bracket (15)	Place in position.
31. Backhoe frame (9) and manifold block (1) or manifold bracket (15)	Two screws (16), washers (17), and new lockwashers (18)	Screw in and tighten using 3/4-inch box wrench.
32. Two hoses (12 and 13), isolator (11), and manifold block (1) or manifold bracket (15)	Clamp (19)	Place in position.

MANIFOLD BLOCK - CONTINUED

LOCATION	ITEM	ACTION	REMARKS
----------	------	--------	---------

33. Clamp (19) and manifold block (1) or manifold bracket (15)

Screw (20) and new special nut (21)

Screw together and tighten using 9/16-inch, 1/2-inch drive socket, ratchet handle, and 9/16-inch open-end wrench.

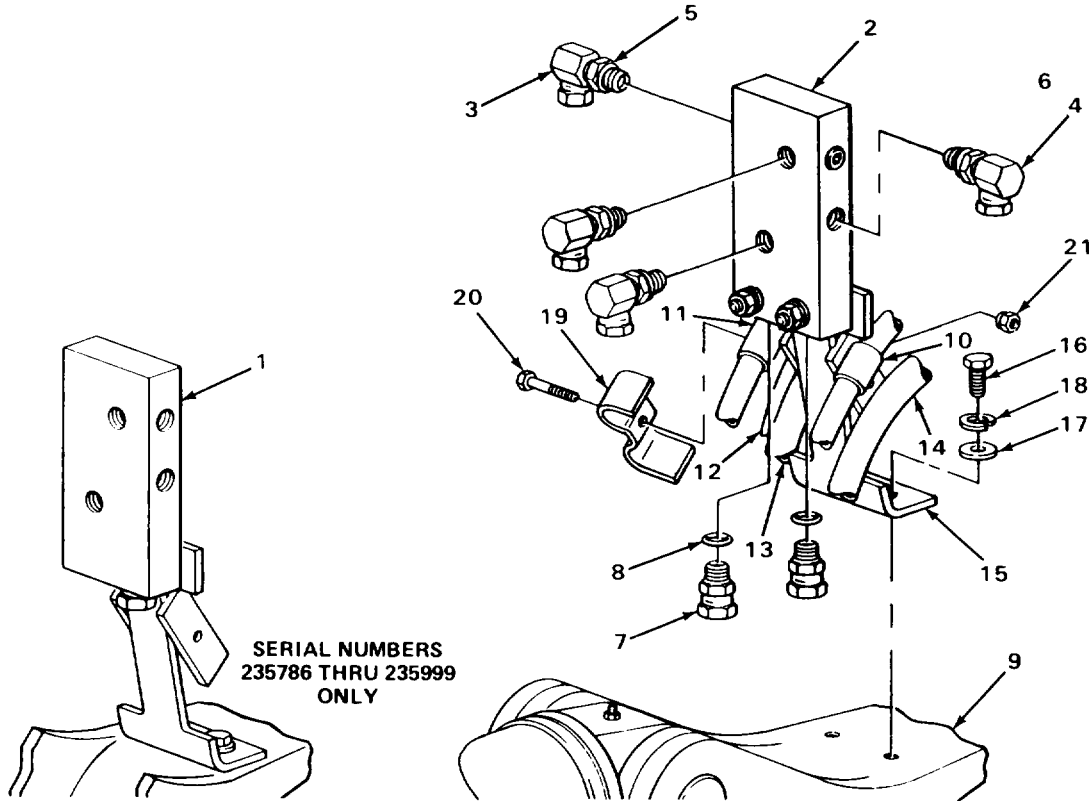

TA243345

MANIFOLD BLOCK - CONTINUED

LOCATION	ITEM	ACTION REMARKS
INSTALLATION - CONTINUED		
34. Hose (1) isolator (2), and manifold block (3) or manifold bracket (4)	Clamp (5)	Place in position.
35. Clamp (5) and manifold block (3) or manifold bracket (4)	Screw (6) and new special nut (7)	Screw together and tighten using 9/16-inch, 1/2-inch drive socket, ratchet handle, and 9/16-inch open-end wrench.
36. Two union adapters (8)	Two hoses (9 and 10)	<ol style="list-style-type: none"> Take off tags. Uncap. Screw on and tighten using two 1-inch open-end wrenches.
37. Eight straight adapters (11)	Six hoses (12) and two hoses (13)	<ol style="list-style-type: none"> Take off tags. Uncap. Screw in and tighten using 7/8-inch and 1-inch open-end wrenches.
38. Two union adapters (14)	Two hoses (15 and 16)	<ol style="list-style-type: none"> Take off tags. Uncap. Screw in and tighten using 7/8-inch and 1-inch open-end wrenches.
39. Loader backhoe	Transmission	Check fluid level and add proper amount and grade (TM 5-2420-222-10).
40. Engine		Start and run at high idle (TM 5-2420-222-10).
41. Manifold block		<ol style="list-style-type: none"> Operate backhoe (TM 5-2420-222-10) and check for leaks. If leaking at any connection, tighten using 7/8-inch and two 1-inch open-end wrenches. If leaking does not stop, shut down engine (TM 5-2420-222-10) and replace defective connection packing or manifold block as outlined in this task. If found leaking, repeat steps 38 thru 40.

MANIFOLD BLOCK - CONTINUED

LOCATION	ITEM	ACTION	REMARKS
42.	Engine	If still running, shut down (TM 5-2420-222-10).	

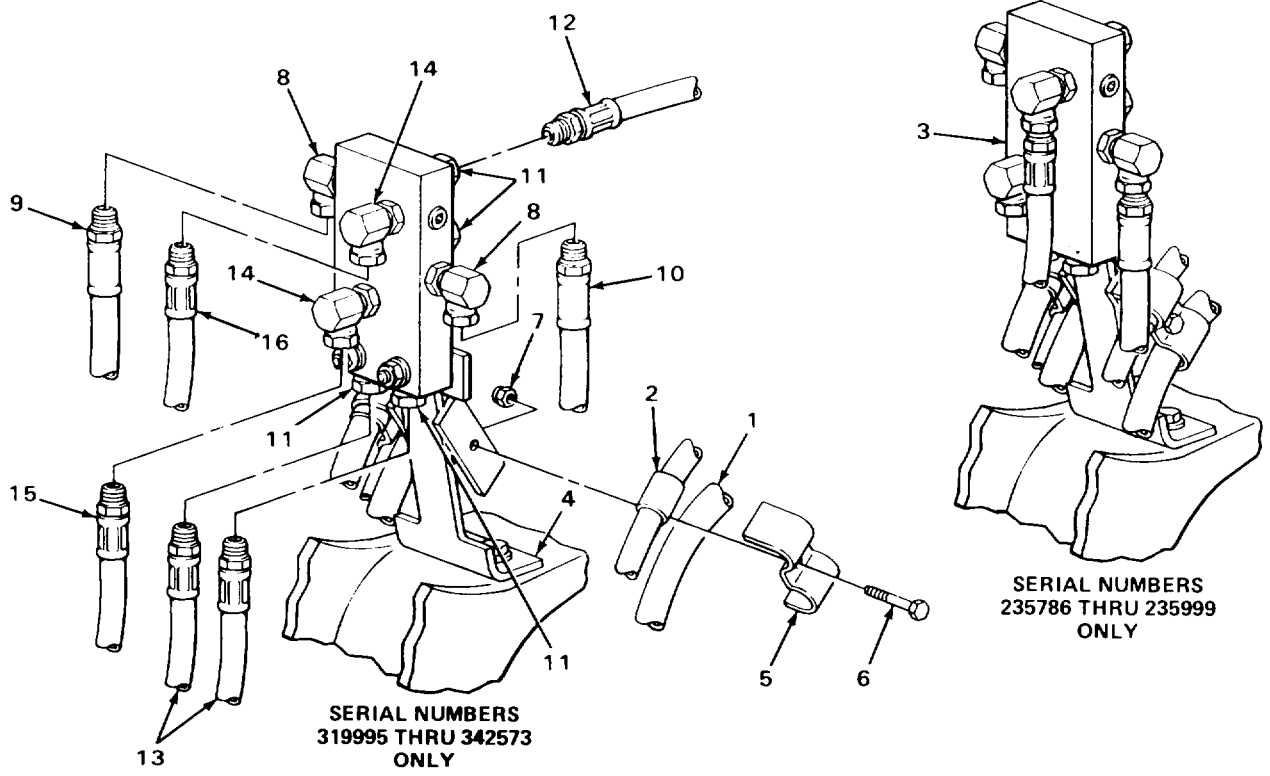

TASK ENDS HERE

TA243346

LOADER CONTROL VALVE MOUNTING BRACKET

This task covers:

- | | |
|---------------------------|---|
| a. Removal (page 2-1282) | c. Inspection/Replacement (page 2-1283) |
| b. Cleaning (page 2-1282) | d. Installation (page 2-1284) |
-

INITIAL SETUP

Tools

Handle, ratchet, 1/2-inch drive
 Socket, 1/2-inch drive, 3/4-inch
 Wrench, torque, 1/2-inch drive,
 0 to 150 foot-pound capacity

Personnel Required

One

Equipment Condition

Loader control valve removed (page 2-1285)

Materials/Parts

Lockwasher, bracket screw
 (two required)
 Rags, wiping (item 21, Appendix C)
 Solvent, drycleaning
 (item 28, Appendix C)

LOCATION	ITEM	ACTION	REMARKS
-----------------	-------------	---------------	----------------

REMOVAL

- | | | |
|---|------------------------------------|--|
| 1. Bracket (1), rear axle housing (2) and transmission case (3) | Two screws (4) and lockwashers (5) | a. Using 3/4-inch, 1/2-inch drive socket and ratchet handle, unscrew and take out.
b. Get rid of lockwashers (5). |
| 2. Rear axle housing (2) | Bracket (1) | Take off. |

CLEANING

NOTE

For more information on how to clean parts, go to General Maintenance Instructions (page 2-137).

LOADER CONTROL VALVE MOUNTING BRACKET - CONTINUED

LOCATION	ITEM	ACTION	REMARKS
----------	------	--------	---------

WARNING

Drycleaning solvent P-D-680 is toxic and flammable. Wear protective goggles and gloves and use only in a well ventilated area. Avoid contact with skin, eyes, and clothes and don't breathe vapors. Do not use near open flame or excessive heat. The flashpoint is 100°F to 138°F (38° to 59°C). If you become dizzy while using cleaning solvent, get fresh air immediately and get medical aid. If contact with eyes is made, wash your eyes with water and get medical aid immediately.

- | | | |
|----|-----------------|---|
| 3. | All metal parts | a. Clean in drycleaning solvent.
b. Using clean, dry rags, wipe dry. |
|----|-----------------|---|

INSPECTION/REPLACEMENT

NOTE

For more information on how to inspect parts, go to General Maintenance Instructions (page 2-137).

Replace defective parts as needed.

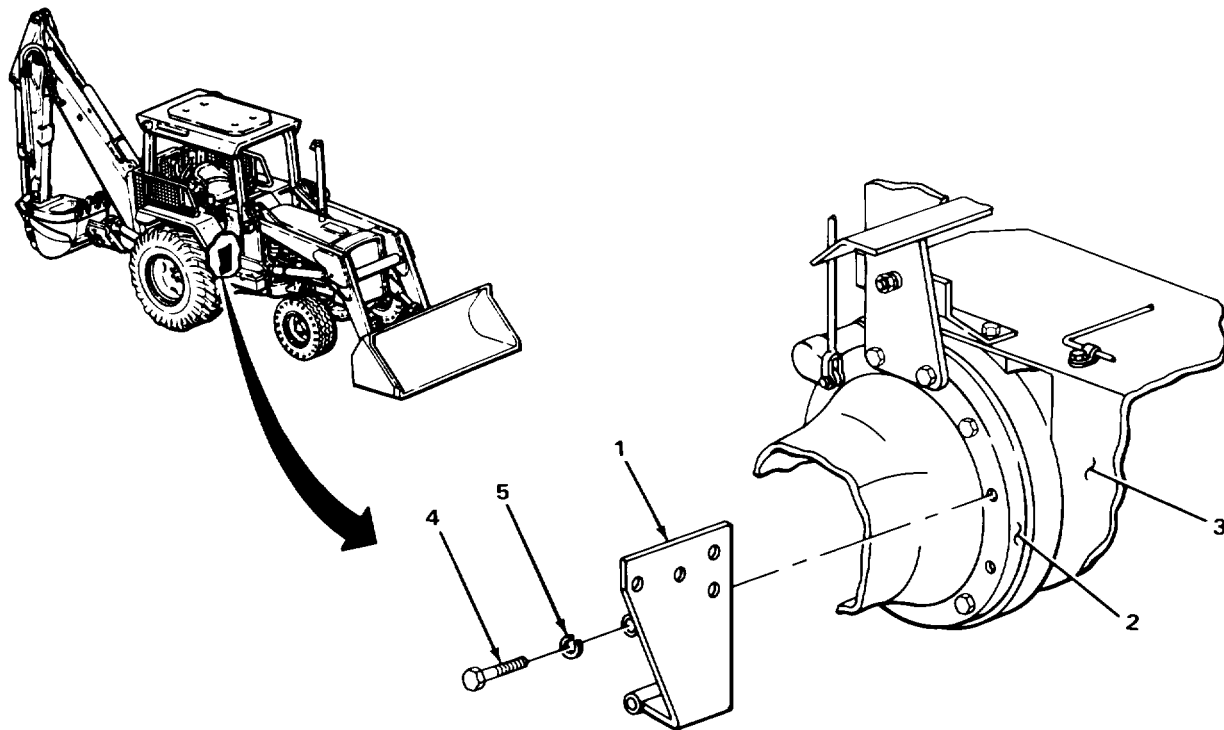

TA243347

LOADER CONTROL VALVE MOUNTING BRACKET - CONTINUED

LOCATION	ITEM	ACTION	REMARKS
INSPECTION/REPLACEMENT - CONTINUED			
4.	All metal parts		Look for cracks, breaks, and abnormal bends.
5.	All threaded parts		Look for damaged threads.
INSTALLATION			
6. Rear axle housing (1)	Bracket (2)		Place in position.
7. Rear axle housing (1), bracket (2), and Transmission case (3)	Two screws (4) and new lockwashers (5)	a.	Screw in until snug using 3/4-inch, 1/2-inch drive socket and ratchet handle.
		b.	Using 3/4-inch, 1/2-inch drive socket and 0 to 150 foot-pound capacity torque wrench, tighten to 85 foot-pounds (115 N•m) torque.

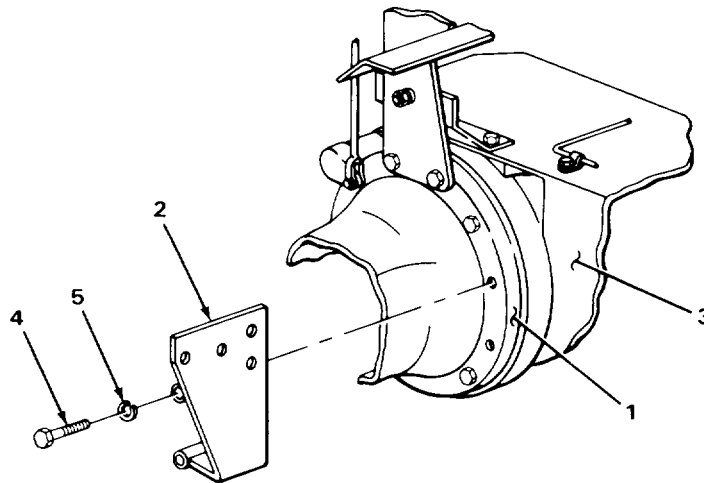

NOTE

FOLLOW-ON MAINTENANCE: Install loader control valve (page 2-1285).

TASK ENDS HERE

TA243348

LOADER CONTROL VALVE

This task covers:

- | | |
|------------------------------|---|
| a. Removal (page 2-1286) | d. Inspection/Replacement (page 2-1289) |
| b. Disassembly (page 2-1288) | e. Assembly (page 2-1290) |
| c. Cleaning (page 2-1288) | f. Installation (page 2-1290) |
-

INITIAL SETUP**Tools**

Handle, ratchet, 1/2-inch drive
 Knife, pocket
 Pan, drain
 Socket, 1/2-inch drive, 3/4-inch
 Vise, machinist's
 Wrench, open-end, 7/8-inch
 Wrench, open-end, 1-inch
 (two required)
 Wrench, open-end, 1 1/4-inch
 (two required)

Materials/Parts

Lockwasher, valve screw
 (three required)
 Packing, connector-to-valve
 Packing, special connector-to-valve

Materials/Parts - Continued

Packing, tee-to-valve (two required)
 Packing, long tee-to-valve (two required)
 Rags, wiping (item 21, Appendix C)
 Solvent, drycleaning (item 28, Appendix C)
 Tags, marking (item 30, Appendix C)

Personnel Required

Two

Equipment Condition

Loader control valve handle and linkage
 removed (page 2-1324)

LOADER CONTROL VALVE - CONTINUED

LOCATION	ITEM	ACTION	REMARKS
REMOVAL			
<u>WARNING</u>			
<p>Do not attempt to disconnect hydraulic lines and fittings while engine is running or before hydraulic system pressure has been released. When engine is running, hydraulic system is under pressure. Hydraulic system pressure should be 0 psi (0 kPa) before lines are disconnected. A line or fitting disconnected under pressure will blow off with a lot of force and could cause serious injury to personnel.</p>			
<p>Be careful when draining hot fluids. Wear gloves to protect your hands from hot parts and fluids or severe burns could result.</p>			
1. Long tee (1)	Two hoses (2 and 3)	a. Place drain pan underneath. b. Using 7/8-inch and 1-inch open-end wrenches, unscrew and take out. c. Cap (page 2-137). d. Tag (page 2-137).	
2 Tee (4)	Two hoses (5 and 6)	a. Using 7/8-inch and 1-inch open-end wrenches, unscrew and take out. b. Cap (page 2-137). c. Tag (page 2-137).	
3 Special Oil line (8)		a. Using 1-inch and 1 1/4-inch open-end connector (7) wrenches, unscrew and take off. b. Plug (page 2-137). c. Tag (page 2-137).	
4 Tee (9)	Union (10) with assembled parts	a. Using two 1-inch open-end wrenches, unscrew and take out. b. Cap (page 2-137). c. Tag (page 2-137).	
5 Hose (11)		a. Using 7/8-inch and 1-inch open-end wrenches, unscrew and take out. b. Cap (page 2-137). c. Tag (page 2-137).	
6 Long tee (12)	Two hoses (13 and 14)	a. Using 7/8-inch and 1-inch open-end wrenches, unscrew and take out. b. Cap (page 2-137). c. Tag (page 2-137).	

LOADER CONTROL VALVE - CONTINUED

LOCATION	ITEM	ACTION	REMARKS
7. Connector(15)	Oil line (16)	a. Using two 1 1/4-inch open-end wrenches, unscrew and take off. b. Cap (page 2-137). c. Tag (page 2-137).	
8. Bracket (17) and valve (18)	Three screws (19) and lockwashers (20)	a. Have assistant support valve (18). b. Using 3/4-inch, 1/2-inch drive socket and ratchet handle, unscrew and take out. c. Get rid of lockwashers (20).	

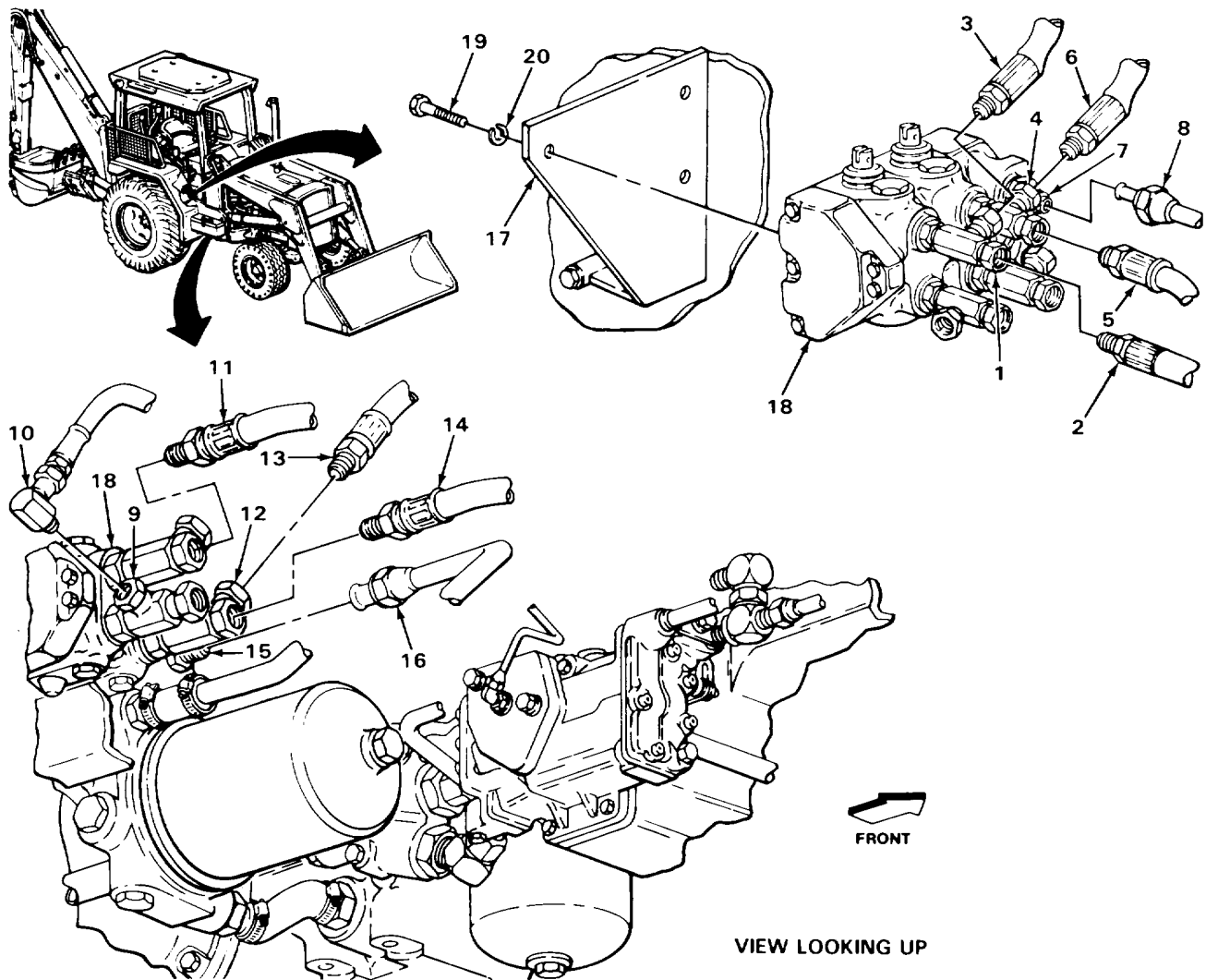

TA243349

LOADER CONTROL VALVE - CONTINUED

LOCATION	ITEM	ACTION	REMARKS
REMOVAL - CONTINUED			
	9. Bracket (1) assembled parts	Valve (2) with	<ol style="list-style-type: none"> Have assistant take off. Allow fluid to drain into drain pan. Get rid of drained fluid (page 2-137).
DISASSEMBLY			
	10. Valve (2) assembled packing (4)	Connector (3) with	<ol style="list-style-type: none"> Place valve (2) in machinist's vise. Using 1 1/4-inch open-end wrench, unscrew and take out.
	11. Connector (3)	Packing (4)	<ol style="list-style-type: none"> Using pocket knife, take off. Get rid of.
1	2. Valve (2)	Special connector (5) with assembled packing (6)	Using 1 1/4-inch open-end wrench, unscrew and take out.
	13. Special connector (5)	Packing (6)	<ol style="list-style-type: none"> Using pocket knife, take off. Get rid of.
	14. Two long tees (7 and 8), two tees (9 and 10), and valve (2)	Four nuts (11 thru 14)	Using two 1-inch open-end wrenches, loosen.
	15. Valve (2)	Two long tees (7 and 8) and two tees (9 and 10) with assembled parts	<ol style="list-style-type: none"> Note relative positions for proper placement during assembly. Using 1-inch open-end wrench, unscrew and take out. Take valve (2) out of machinist's vise.
	16. Two long tees (7 and 8) and two tees (9 and 10)	Four packings (15 thru 18)	<ol style="list-style-type: none"> Using pocket knife, take off. Get rid of.

CLEANING

NOTE

For more information on how to clean parts, go to **General Maintenance Instructions (page 2-137)**.

LOADER CONTROL VALVE - CONTINUED

LOCATION	ITEM	ACTION	REMARKS
----------	------	--------	---------

WARNING

Drycleaning solvent P-D-680 is toxic and flammable. Wear protective goggles and gloves and use only in a well ventilated area. Avoid contact with skin, eyes, and clothes and don't breathe vapors. Do not use near open flame or excessive heat. The flashpoint is 100°F to 1380F (38° to 59°C). If you become dizzy while using cleaning solvent, get fresh air immediately and get medical aid. If contact with eyes is made, wash your eyes with water and get medical aid immediately.

17. Valve (2)		<ul style="list-style-type: none"> a. Using clean rags dampened with dry-cleaning solvent, wipe clean. b. Using clean, dry rags, wipe dry.
18.	All other metal parts	<ul style="list-style-type: none"> a. Clean in drycleaning solvent. b. Using clean, dry rags, wipe dry.

INSPECTION/REPLACEMENT

NOTE

For more information on how to inspect parts, go to **General Maintenance Instructions (page 2-137)**.

Replace defective parts as needed.

19. All metal parts	<ul style="list-style-type: none"> a. Look for cracks and breaks. b. Look for damaged threads.
---------------------	--

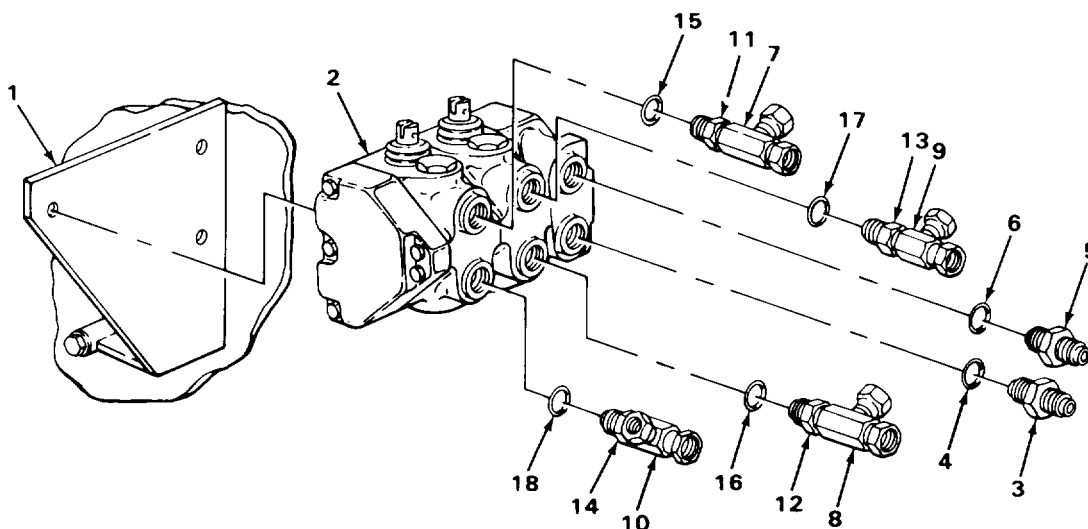

TA243350

LOADER CONTROL VALVE - CONTINUED

LOCATION	ITEM	ACTION REMARKS
ASSEMBLY		
20. Two long tees (1 and 2) and two tees (3 and 4)	Four nuts (5 thru 8)	Screw on all the way.
21.	Four new packings (9 thru 12)	Place in position.
22. Valve (13)	Two long tees (1 and 2), two tees (3 and 4) with assembled parts	a. Place valve in machinist's vise. b. Screw in and tighten to position noted during disassembly using 1-inch open-end wrench.
23. Two long tees (1 and 2), two tees (3 and 4), and valve (13)	Four nuts (5 thru 8)	Using two 1-inch open-end wrenches, tighten until seated against valve (13).
24. Special connector (14)	New packing (15)	Place in position.
25. Valve (13)	Special connector (14) with assembled packing (15)	Screw in and tighten using 1 1/4-inch open-end wrench.
26. Connector(16)	New packing (17)	Place in position.
27. Valve (13)	Connector (16) with assembled packing (17)	a. Screw in and tighten using 1 1/4-inch open-end wrench. b. Take valve (13) out of machinist's vise.
INSTALLATION		
28. Bracket (18) assembled parts	Valve (13) with	Have assistant place in position.
29. Bracket (18) and valve (13)	Three screws (19) and new lock-washers (20)	a. Have assistant support valve (13). b. Screw in and tighten using 3/4-inch, 1/2-inch drive socket and ratchet handle.
30. Connector(16)	Oil line (21)	a. Take off tag. b. Unplug. c. Screw on and tighten using 1 1/4-inch open-end wrench.

LOADER CONTROL VALVE - CONTINUED

LOCATION	ITEM	ACTION	REMARKS
31. Long tee (1) (22 and 23)	Two hoses b. Unplug.	a. Take off tags. c. Screw on and tighten using 7/8-inch and 1-inch open-end wrenches.	
32. Tee (3)	Hose (24)	a. Take off tag. b. Unplug. c. Screw on and tighten using 7/8-inch and 1-inch open-end wrenches.	
33. Union (25) with assembled parts	a. Take off tag. b. Unplug.	c. Screw on and tighten using two 1-inch open-end wrenches.	

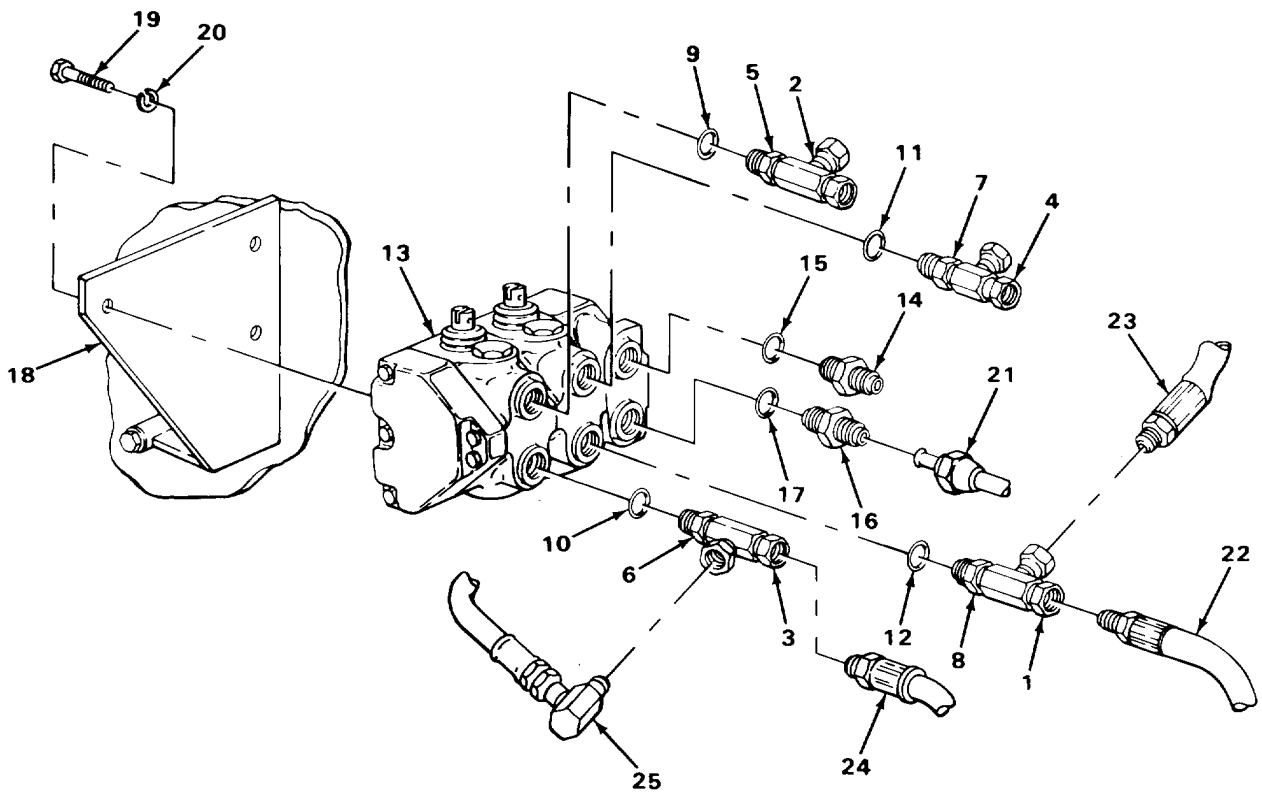

TA243351

LOADER CONTROL VALVE - CONTINUED

LOCATION	ITEM	ACTION REMARKS
INSTALLATION - CONTINUED		
34. Special connector (1)	Oil line (2)	<ul style="list-style-type: none"> a. Take off tag. b. Unplug. c. Screw on and tighten using 1 1/4-inch open-end wrench.
35. Tee (3) (4 and 5)	Two hoses b. Uncap.	<ul style="list-style-type: none"> a. Take off tags. c. Screw on and tighten using 7/8-inch and 1-inch open-end wrenches.
36. Long tee (6) (7 and 8)	Two hoses b. Uncap.	<ul style="list-style-type: none"> a. Take off tags. c. Screw on and tighten using 7/8-inch and 1-inch open-end wrenches.
37. Loader control valve	Loader control valve handle and linkage	<p>Install (page 2-1324).</p> <p>Do not install right platform at this time.</p>
38. Loader backhoe	Transmission	Check fluid level and add proper amount and grade (TM 5-2420-222-10).
39.	Engine	Start and run at high idle (TM 5-2420-222-10).
40.	Loader control valve	<ul style="list-style-type: none"> a. Operate loader bucket (TM 5-2420-222-10) and check for leaks. b. If leaking at any connection, tighten using 7/8-inch, two 1 1/4-inch, and two 1-inch open-end wrenches. c. If leaking does not stop, shut down engine (TM 5-2420-222-10) and replace defective packing or component as outlined in this task. d. If leaks were found, repeat steps 38 thru 40.
41.	Engine	If still running, shut down (TM 5-2420-222-10).

LOADER CONTROL VALVE - CONTINUED

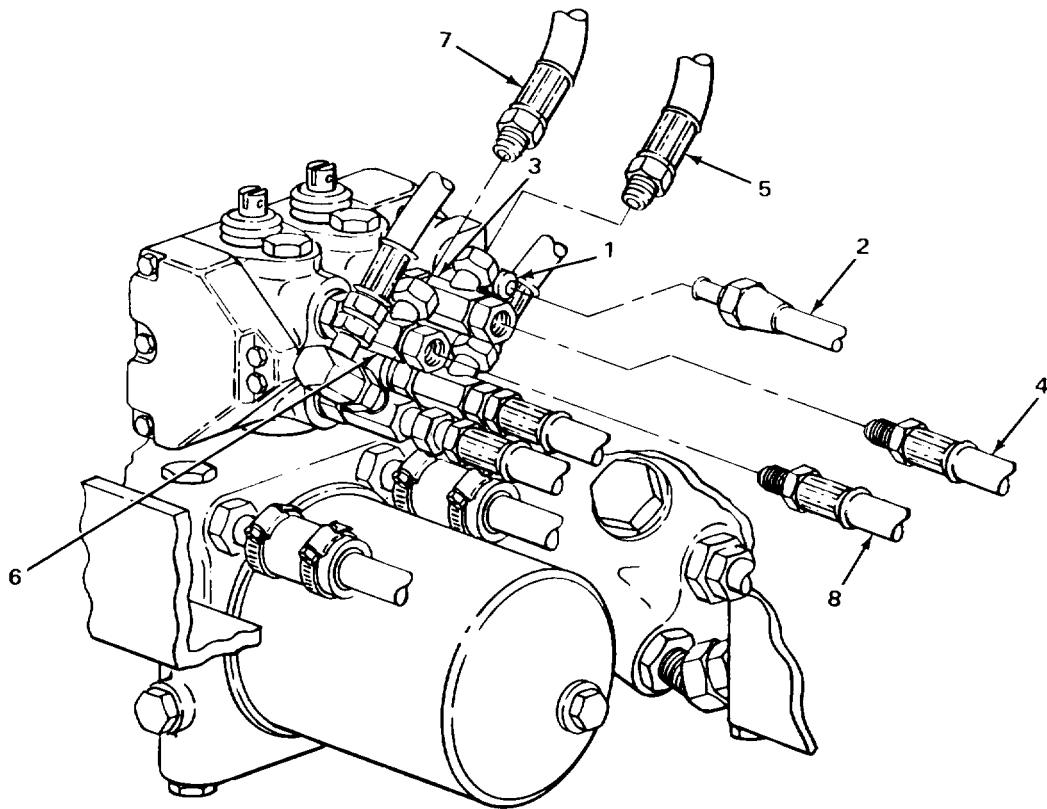

NOTE

FOLLOW-ON MAINTENANCE: Install right platform (page 2-1079).

TASK ENDS HERE

TA243352

JAW CONTROL (DIRECT LINEAR) VALVE LINKAGE

This task covers:

- a. Removal (page 2-1294)
 - b. Cleaning (page 2-1295)
 - c. Inspection/Replacement (page 2-1296)
 - d. Installation (page 2-1296)
-

INITIAL SETUP

Tools

Pliers, long roundnose

Materials/Parts

Pin, cotter, valve bracket
(two required)
Pin, cotter, valve link
Rags, wiping (item 21, Appendix C)
Solvent, drycleaning
(item 28, Appendix C)

Personnel Required

One

Equipment Condition

NOTE

The following only applies to loader backhoes with Serial Numbers 235786 thru 235999.

- 1. Rear platform removed (page 2-1117)

NOTE

The following only applies to loader backhoes with Serial Numbers 319995 thru 342573.

- 2. Right rear platform removed (page 2-1110)
-

LOCATION	ITEM	ACTION	REMARKS
----------	------	--------	---------

REMOVAL

1. Bracket (1) and long pedal (2)	Cotter pin (3)	a. Using long roundnose pliers, straighten ends and take out. b. Get rid of.	
2. Bracket (1) and link (4)	Long pedal (2)	Slide off.	
3. Bracket (1) and short pedal (5)	Cotter pin (6)	a. Using long roundnose pliers, straighten ends and take out. b. Get rid of.	
4. Bracket (1) and link (4)	Short pedal (5)	Slide off.	

JAW CONTROL (DIRECT LINEAR) VALVE LINKAGE - CONTINUED

LOCATION	ITEM	ACTION	REMARKS
5. Link (4) and valve (7)	Cotter pin (8)	a. Using long roundnose pliers, straighten ends and take out. b. Get rid of.	
6. Valve (7)	Link (4)	Slide off.	

CLEANING

NOTE

For more information on how to clean parts, go to General Maintenance Instructions (page 2-137).

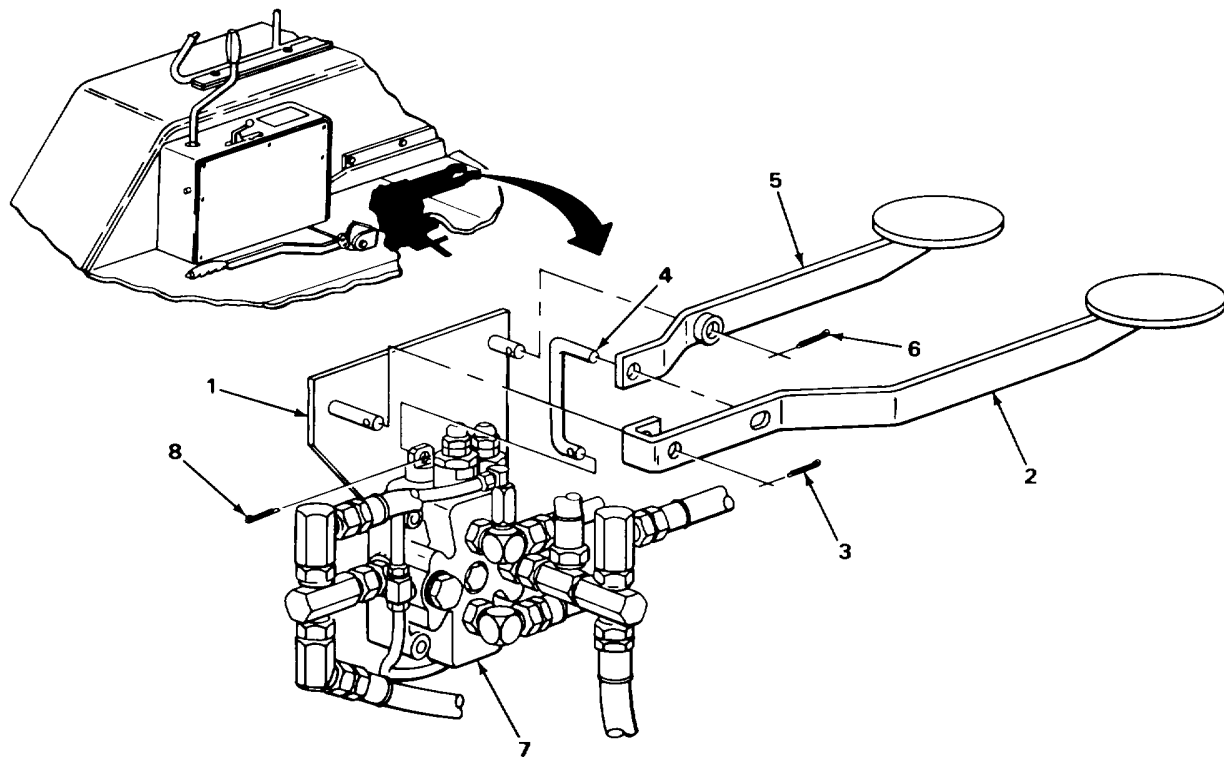

TA243353

JAW CONTROL (DIRECT LINEAR) VALVE LINKAGE - CONTINUED

LOCATION	ITEM	ACTION	REMARKS
CLEANING - CONTINUED			
WARNING			
<p>Drycleaning solvent P-D-680 is toxic and flammable. Wear protective goggles and gloves and use only in a well ventilated area. Avoid contact with skin, eyes, and clothes and don't breathe vapors. Do not use near open flame or excessive heat. The flashpoint is 100°F to 138°F (38° to 59°C). If you become dizzy while using cleaning solvent, get fresh air immediately and get medical aid. If contact with eyes is made, wash your eyes with water and get medical aid immediately.</p>			
7.	All metal parts	a. Clean in drycleaning solvent. b. Using clean, dry rags, wipe dry.	
INSPECTION/REPLACEMENT			
NOTE			
<p>For more information on how to inspect parts, go to General Maintenance Instructions (page 2-137).</p> <p>Replace defective parts as needed.</p>			
8.	All metal parts		Look for cracks, breaks, and abnormal bends.
INSTALLATION			
9.	Valve (1)	Link (2)	Place in position.
10.	Valve (1) and link (2)	New cotter pin (3)	a. Place in position. b. Using long roundnose pliers, bend ends back.
11.	Bracket (4) and link (2)	Short pedal (5)	Place in position.
12.	Bracket (4) and short pedal (5)	New cotter pin (6)	a. Place in position. b. Using long roundnose pliers, bend ends back.
13.	Bracket (4) and link (2)	Long pedal (5)	Place in position.
14.	Bracket (4) and long pedal (7)	New cotter pin (8)	a. Place in position. b. Using long roundnose pliers, bend ends back.

JAW CONTROL (DIRECT LINEAR) VALVE LINKAGE - CONTINUED

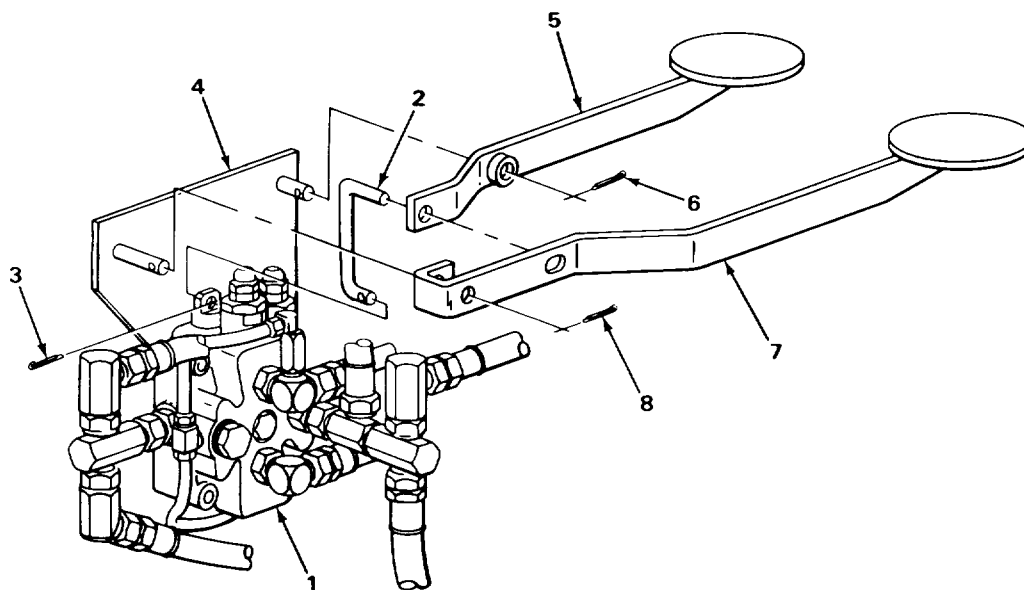

NOTE

FOLLOW-ON MAINTENANCE:

Perform the following only on loader backhoes with Serial Numbers 235786 thru 235999.

1. Install rear platform (page 2-1117).

Perform the following only on loader backhoes with Serial Numbers 319995 thru 342573.

2. Install right rear platform (page 2-1110).

TASK ENDS HERE

TA243354

JAW CONTROL (DIRECT LINEAR) VALVE BRACKET

This task covers:

- | | |
|---|-------------------------------|
| a. Removal (page 2-1298) | d. Repair (page 2-1300) |
| b. Cleaning (page 2-1299) | e. Installation (page 2-1300) |
| c. Inspection/Replacement (page 2-1300) | |
-

INITIAL SETUP

Tools

Handle, ratchet, 1/2-inch drive
 Socket, 1/2-inch drive, 9/16-inch
 Threading set, screw

Materials/Parts

Lockwasher, bracket screw
 Rags, wiping (item 21, Appendix C)
 Solvent, drycleaning
 (item 28, Appendix C)

Personnel Required

One

Equipment Condition

1. Jaw control (direct linear) valve linkage removed (page 2-1294)

NOTE

The following only applies to loader backhoes with Serial Numbers 235786 thru 235999.

2. Jaw control valve removed (page 2-1242)

NOTE

The following only applies to loader backhoes with Serial Numbers 319995 thru 342573.

3. Jaw direct linear valve removed (page 2-1250)
-

LOCATION	ITEM	ACTION	REMARKS
-----------------	-------------	---------------	----------------

REMOVAL

- | | | |
|-----------------------------------|--------------------------------------|---|
| 1. Main frame (1) and bracket (2) | Two screws (3) and lockwashers (4) | a. Using 9/16-inch, 1/2-inch drive socket and ratchet handle, unscrew and take out.
b. Get rid of lockwashers (4). |
| 2. Main frame (1) | Bracket (2) with assembled screw (5) | Take off. |

JAW CONTROL (DIRECT LINEAR) VALVE BRACKET - CONTINUED

LOCATION	ITEM	ACTION	REMARKS
----------	------	--------	---------

NOTE

Upper jaw control (direct linear) valve mounting screw must be maintained with the bracket because it cannot be removed with bracket installed on loader backhoe.

3. Bracket (2)	Screw (5)	Take out.	
----------------	-----------	-----------	--

CLEANING

NOTE

For more information on how to clean parts, go to General Maintenance Instructions (page 2-137).

WARNING

Drycleaning solvent P-D-680 is toxic and flammable. Wear protective goggles and gloves and use only in a well ventilated area. Avoid contact with skin, eyes, and clothes and don't breathe vapors. Do not use near open flame or excessive heat. The flashpoint is 100°F to 138°F (38° to 59°C). If you become dizzy while using cleaning solvent, get fresh air immediately and get medical aid. If contact with eyes is made, wash your eyes with water and get medical aid immediately.

- | | |
|--------------------|---|
| 4. All metal parts | <ul style="list-style-type: none"> a. Clean in drycleaning solvent. b. Using clean, dry rags, wipe dry. |
|--------------------|---|

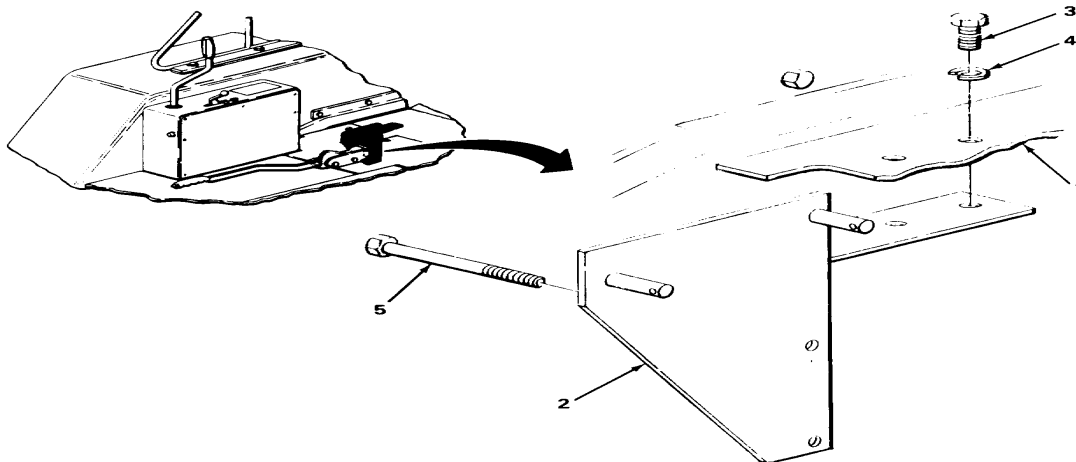

TA243355

JAW CONTROL (DIRECT LINEAR) VALVE BRACKET - CONTINUED

LOCATION	ITEM	ACTION	REMARKS
INSPECTION/REPLACEMENT			
NOTE			
For more information on how to inspect parts, go to General Maintenance Instructions (page 2-137).			
Replace defective parts which cannot be repaired.			
5.	All metal parts		Look for cracks, bends, and breaks.
6.	All threaded parts		Look for damaged threads.
REPAIR			
7.	Bracket (1)		If threads are damaged, using screw threading set, restore threads.
INSTALLATION			
8. Bracket (1)	Screw (2)		Place in position.
9. Main frame (3)	Bracket (1) with assembled screw (2)		Place in position.
10. Bracket (1) and main frame (3)	Two screws (4) and new lockwasher (5)		Screw in and tighten using 9/16-inch, 1/2-inch drive socket and ratchet handle.
11. Loader backhoe	Jaw control (direct linear) valve linkage		Install (page 2-1294). Do not install rear platform or right rear platform at this time.
12.	Jaw control valve		On loader backhoes with Serial Numbers 235786 thru 235999, install (page 2-1242).
13.	Jaw direct linear valve		On loader backhoes with Serial Numbers 319995 thru 342573, install (page 2-1250).

JAW CONTROL (DIRECT LINEAR) VALVE BRACKET - CONTINUED

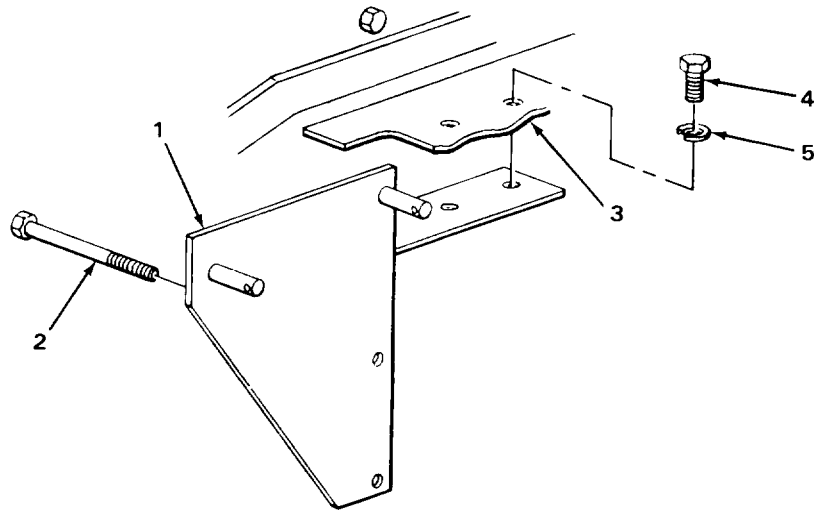

TASK ENDS HERE

TA243356

2-1301

BACKHOE CONTROL VALVE LEVERS AND LINKAGE (SERIAL NUMBERS 235786 THRU 235999 ONLY)

This task covers:

- | | |
|---|-------------------------------|
| a. Removal (page 2-1302) | e. Repair (page 2-1308) |
| b. Disassembly (page 2-1303) | f. Assembly (page 2-1308) |
| c. Cleaning (page 2-1306) | g. Installation (page 2-1312) |
| d. Inspection/Replacement (page 2-1308) | |

INITIAL SETUP

Tools

Extension, 1/2-inch drive, 10-inch
 Hammer, ball-peen, 1-pound head
 Handle, ratchet, 1/2-inch drive
 Pliers, long roundnose
 Pliers, snapping
 Punch, straight drive-pin, 1/4-inch
 Socket, 1/2-inch drive, 9/16-inch
 Threading set, screw
 Vise, machinist's

Materials/Parts

Detergent, GP (item 7, Appendix C)
 Grease (LO 5-2420-222-12)
 Lockwasher, mounting frame screw
 (four required)

Materials/Parts - Continued

Pin, cotter, connector link pin
 (six required)
 Pin, cotter, handle mount pin
 (two required)
 Pin, cotter, pivot shaft (two required)
 Rags, wiping (item 21, Appendix C)
 Solvent, drycleaning (item 28, Appendix C)

Personnel Required

One

Equipment Condition

Backhoe valve box cover removed
 (page 2-1157)

LOCATION	ITEM	ACTION	REMARKS
----------	------	--------	---------

REMOVAL

- | | | |
|---|--|--|
| 1. Six spool devices (1) and six connector pins (2) | Six cotter pins (3) | a. Using long roundnose pliers, straighten ends and pull out.
b. Get rid of. |
| 2. Six spool devices (1), two connector links (4), and four connector links (5) | Six connector pins (2) | Take out. |
| 3. Mounting frame (6) and backhoe valve box (7) | Four bolts (8), washers (9), lockwashers (10), and nuts (11) | a. Using 9/16-inch, 1/2-inch drive socket, 10-inch extension, and ratchet handle, unscrew and take apart.
b. Get rid of lockwashers (10). |

BACKHOE CONTROL VALVE LEVERS AND LINKAGE (SERIAL NUMBERS 235786 THRU 235999 ONLY) - CONTINUED

LOCATION	ITEM	ACTION	REMARKS
4. Backhoe valve box (7) and six spool devices (1)	Mounting frame (6) with assembled parts	Take off.	
DISASSEMBLY			
5. Two control levers (12)	Two nuts (13)	Unscrew and take off.	
6. Two four way levers (14)	Two nuts (15)	Unscrew and take off.	
7. Two control levers (12) and two four way levers (14)	Four hand lever grips (16)	Twist off.	

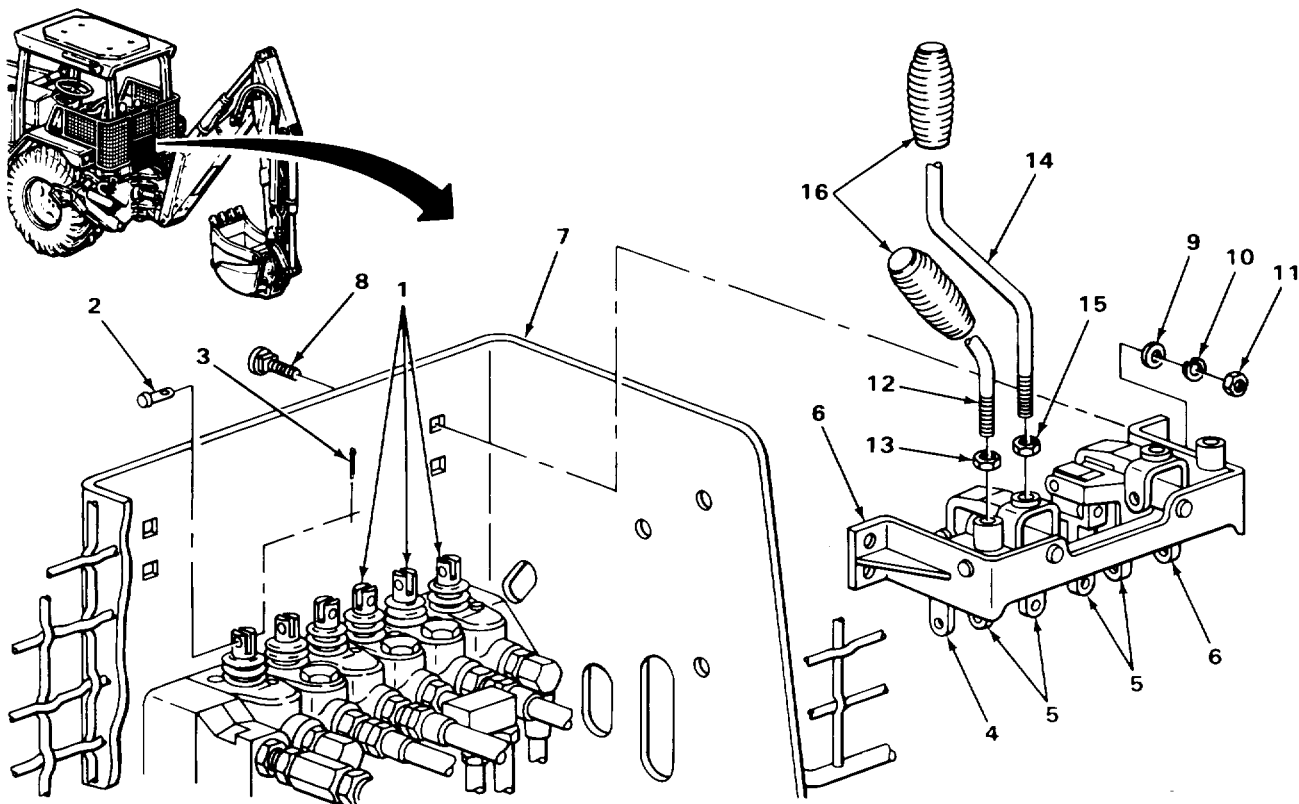

TA243357

BACKHOE CONTROL VALVE LEVERS AND LINKAGE (SERIAL NUMBERS 235786 THRU 235999 ONLY) - CONTINUED

LOCATION	ITEM	ACTION	REMARKS
DISASSEMBLY - CONTINUED			
NOTE			
Linkage for both four way control levers is disassembled the same way. Backhoe bucket control lever linkage is shown. Repeat steps 8 thru 21 for backhoe boom control lever linkage.			
8.	Pivot shaft (1) and mounting frame (2)	Two rings (3)	a. Place mounting frame (2) in machinist's vise. b. Using snapping pliers, take off.
9.	Mounting frame (2), pivot block (4), and three washers (5)	Pivot shaft (1)	Using 1-pound head ball-peen hammer and 1/4-inch straight drive-pin punch, tap off.
10.	Mounting frame (2)	Pivot block (4) with assembled parts and three washers (5)	a. Take out. b. Take mounting frame (2) out of machinist's vise.
11.	Handle mount (6) and pivot pin (7)	Cotter pin (8)	a. Using long roundnose pliers, straighten ends and take out. b. Get rid of.
12.	Handle mount (6) and pivot block (4)	Pivot pin (7)	Take out.
13.	Handle mount (6)	Pivot block (4) with assembled parts	Take off.
14.	Handle mount (6) and universal block (9)	Spring pin (10)	a. Place handle mount (6) in machinist's vise. b. Using 1-pound head ball-peen hammer and 1/4-inch straight drive-pin punch, tap off.
15.	Handle mount (6)	Universal block (9) with assembled parts	a. Take off. b. Take handle mount (6) out of machinist's vise.
16.	Connector link(11) and universal block (9)	Spring pin (12)	a. Place connector link (11) in machinist's vise. b. Using 1-pound head ball-peen hammer and 1/4-inch straight drive-pin punch, tap out.

BACKHOE CONTROL VALVE LEVERS AND LINKAGE (SERIAL NUMBERS 235786 THRU 235999 ONLY) - CONTINUED

LOCATION	ITEM	ACTION REMARKS
17. Connector link(11)	Universal block (9)	a. Take off. b. Take connector link (11) out of machinist's vise.
18. Pivot block (4) and universal block (13)	Spring pin (14)	a. Place pivot block (4) in machinist's vise. b. Using 1-pound head ball-peen hammer and 1/4-inch straight drive-pin punch, tap out.
19. Pivot block (4)	Universal block (13) with assembled parts	a. Take off. b. Take pivot block (4) out of machinist's vise.
20. Universal block (13) and connector link (15))	Spring pin (16)	a. Place connector link (15) in machinist's vise. b. Using 1-pound head ball-peen hammer and 1/4-inch straight drive-pin punch, tap out.

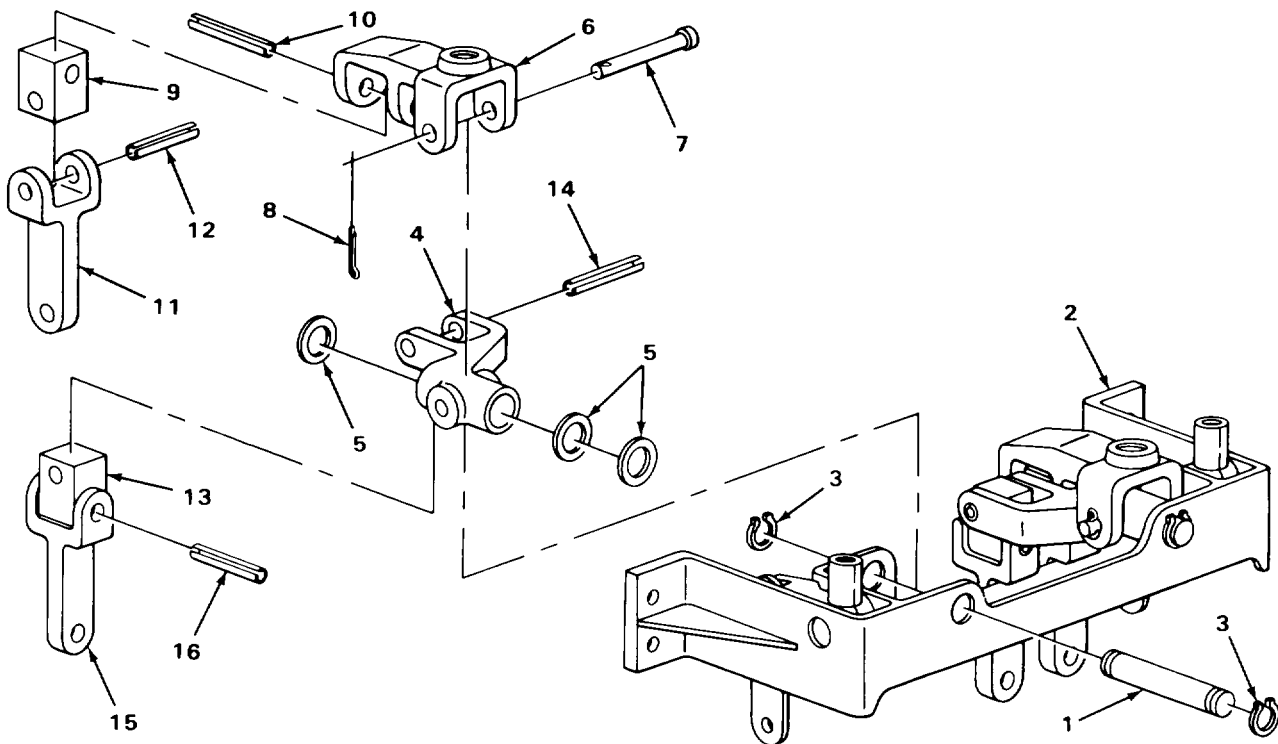

TA243358

BACKHOE CONTROL VALVE LEVERS AND LINKAGE (SERIAL NUMBERS 235786 THRU 235999 ONLY) - CONTINUED

LOCATION	ITEM	ACTION REMARKS
21. Connector link (1)	Universal block (2)	a. Take off. b. Take connector link (1) out of machinist's vise. c. Repeat steps 8 thru 21 for backhoe boom control lever linkage.
NOTE		
Linkage for both stabilizer control levers is disassembled the same way. Left stabilizer control lever linkage is shown. Repeat steps 22 thru 26 for right stabilizer control lever linkage.		
22. Pivot shaft (3) and handle mount (4)	Cotter pin (5)	a. Using long roundnose pliers, straighten ends and take out. b. Get rid of.
23. Handle mount (4) and mounting frame (6)	Pivot shaft (3)	Using 1-pound head ball-peen hammer and 1/4-inch straight drive-pin punch, tap out.
24. Mounting frame (6)	Handle mount (4) with assembled parts	Take out.
25. Handle mount (4) and connector link (7)	Spring pin (8)	a. Place handle mount (4) in machinist's vise. b. Using 1-pound head ball-peen hammer and 1/4-inch straight drive-pin punch, tap out.
26. Handle mount (4)	Connector link (7)	a. Take off. b. Take handle mount (4) out of machinist's vise. c. Repeat steps 22 thru 26 for right stabilizer control lever linkage.

CLEANING
NOTE

For more information on how to clean parts, go to General Maintenance Instructions (page 2-137).

BACKHOE CONTROL VALVE LEVERS AND LINKAGE (SERIAL NUMBERS 235786 THRU 235999 ONLY) - CONTINUED

LOCATION	ITEM	ACTION	REMARKS
27.	All rubber parts	a. Clean in solution of detergent and water. b. Rinse with clean water. c. Using clean, dry rags, wipe dry.	

WARNING

Dry-cleaning solvent P-D-680 is toxic and flammable. Wear protective goggles and gloves and use only in a well ventilated area. Avoid contact with skin, eyes, and clothes and don't breathe vapors. Do not use near open flame or excessive heat. The flashpoint is 100°F to 138°F (38° to 59°C). If you become dizzy while using cleaning solvent, get fresh air immediately and get medical aid. If contact with eyes is made, wash your eyes with water and get medical aid immediately.

28.	All metal parts	a. Clean in dry-cleaning solvent. b. Using clean, dry rags, wipe dry.	
-----	-----------------	--	--

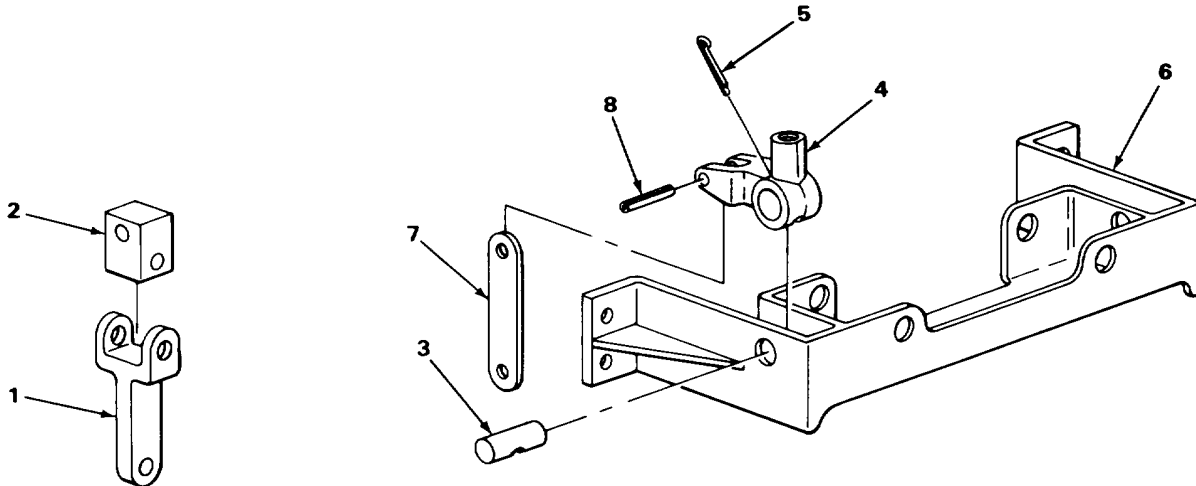

TA243359

BACKHOE CONTROL VALVE LEVERS AND LINKAGE (SERIAL NUMBERS 235786 THRU 235999 ONLY) - CONTINUED

LOCATION	ITEM	ACTION	REMARKS
INSPECTION/REPLACEMENT			
NOTE			
For more information on how to inspect parts, go to General Maintenance Instructions (page 2-137).			
Replace defective parts which cannot be repaired.			
29.	All rubber parts		Look for cracks, breaks, and tears.
30.	All metal parts		Look for cracks, breaks, and abnormal bends.
31.	All threaded parts		Look for damaged threads.
REPAIR			
32.	All threaded parts except hardware		If threads are damaged, using screw threading set, restore threads.
ASSEMBLY			
NOTE			
Linkage for both stabilizer control levers is assembled the same way. Left stabilizer control lever linkage is shown. Repeat steps 33 thru 37 for right stabilizer control lever linkage.			
33. Handle mount (1) vise.	Connector link (2)	a. Place handle mount (1) in machinist's b. Coat with grease. c. Place in position.	
34. Handle mount (1) and connector link (2)	Spring pin (3)	a. Using 1-pound head ball-peen hammer and 1/4-inch straight drive-pin punch, tap in. b. Take handle mount (1) out of machinist's vise.	
35. Mounting frame (4)	Handle mount (1) with assembled parts	a. Coat with grease. b. Place in position.	
36. Mounting frame (4) and handle mount (1)	Pivot shaft (5)	a. Aline holes in handle mount (1) and pivot shaft (5). b. Push into position.	

BACKHOE CONTROL VALVE LEVERS AND LINKAGE (SERIAL NUMBERS 235786 THRU 235999 ONLY) - CONTINUED

LOCATION	ITEM	ACTION	REMARKS
37. Handle mount (1) and pivot shaft (5)	New cotter pin (6)	a. Place in position. b. Using long roundnose pliers, bend ends back. c. Repeat steps 33 thru 37 for right stabilizer control lever linkage.	

NOTE

Linkage for both four way control levers is assembled the same way. Backhoe bucket control lever linkage is shown. Repeat steps 38 thru 51 for backhoe boom control lever linkage.

38. Connector link (7)	Universal block (8)	a. Place connector link (7) in machinist's vise. b. Coat with grease. c. Place in position.	
------------------------	---------------------	---	--

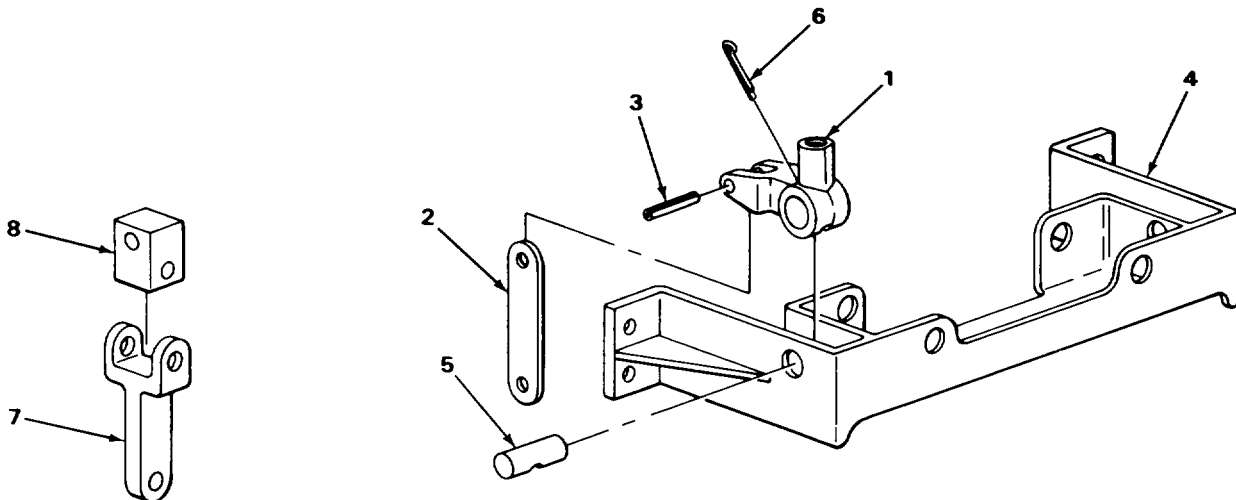

TA243360

BACKHOE CONTROL VALVE LEVERS AND LINKAGE (SERIAL NUMBERS 235786 THRU 235999 ONLY) - CONTINUED

LOCATION	ITEM	ACTION REMARKS
ASSEMBLY - CONTINUED		
39. Universal block (11) and connector link (2)	Spring pin (3)	a. Using 1-pound head ball-peen hammer and 1/4-inch straight drive-pin punch, tap in. b. Take connector link (2) out of machinist's vise.
40. Pivot block (4)	Universal block (11) with assembled parts	a. Place pivot block (4) in machinist's vise. b. Place in position.
41. Pivot block (4) and universal block (1)	Spring pin (5)	a. Using 1-pound head ball-peen hammer and 1/4-inch straight drive-pin punch, tap in. b. Take pivot block (4) out of machinist's vise.
42. Connector link (6)	Universal block (7)	a. Place connector link (6) in machinist's vise. b. Coat with grease. c. Place in position.
43. Connector link (6) and universal block (7)	Spring pin (8)	a. Using 1-pound head ball-peen hammer and 1/4-inch straight drive-pin punch, tap in. b. Take connector link (6) out of machinist's vise.
44. Handle mount (9)	Universal block (7) with assembled parts	a. Place handle mount (9) in machinist's vise. b. Place in position.
45. Handle mount (9) and universal block (7)	Spring pin (10)	a. Using 1-pound head ball-peen hammer and 1/4-inch straight drive-pin punch, tap in. b. Take handle mount (9) out of machinist's vise.
46. Handle mount (9)	Pivot block (4) with assembled parts	a. Coat with grease. b. Place in position.
47. Handle mount (9) and pivot block (6)	Pivot pin (11)	Place in position.

BACKHOE CONTROL VALVE LEVERS AND LINKAGE (SERIAL NUMBERS 235786 THRU 235999 ONLY) - CONTINUED

LOCATION	ITEM	ACTION	REMARKS
48. Handle mount (9) and pivot pin (11)	New cotter pin (12)	a. Place in position. b. Using long roundnose pliers, bend ends back.	
49. Mounting frame (13)	Pivot block (4) with assembled parts and three washers (14)	a. Place mounting frame (13) in machinist's vise. b. Place in position.	
50. Mounting frame (13), pivot block (4), and three washers (14)	Pivot shaft (15)	Push into position.	
51. Mounting frame (13) and pivot shaft (15)	Two rings (16)	a. Using snapping pliers, put on. b. Take mounting frame (13) out of machinist's vise. c. Repeat steps 38 thru 51 for backhoe boom control lever linkage.	

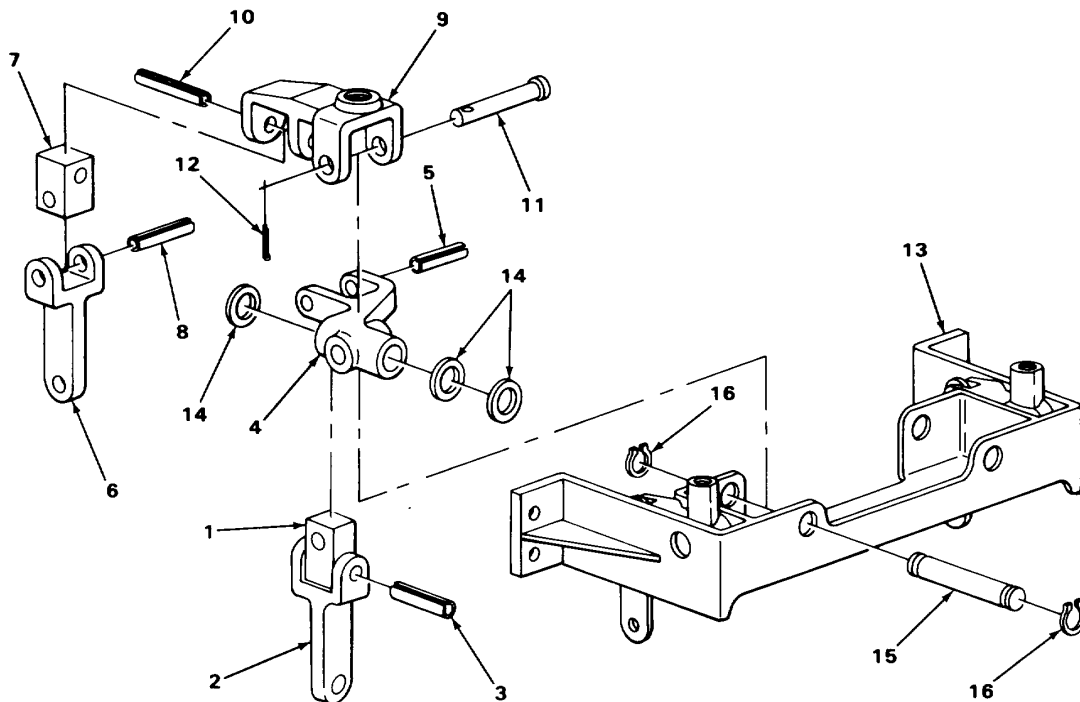

TA243361

BACKHOE CONTROL VALVE LEVERS AND LINKAGE (SERIAL NUMBERS 235786 THRU 235999 ONLY) - CONTINUED

LOCATION	ITEM	ACTION REMARKS
ASSEMBLY - CONTINUED		
52. Two control levers (1) and two four way levers (2)	Four hand lever grips (3)	Twist on.
53. Two four way levers (2)	Two nuts (4)	Screw on all the way.
54. Two control levers (1)	Two nuts (5)	Screw on all the way.
INSTALLATION		
55. Backhoe valve box (6) and six spool clevis (7)	Mounting frame (8) with assembled parts	Place in position.
56. Mounting frame (8) and backhoe valve box (6)	Four bolts (9), washers (10), new lockwashers (11), and nuts (12)	Screw together and tighten using 9/16-inch, 1/2-inch drive socket, 10-inch extension, and ratchet handle.
57. Six spool devises (7), four connector links (13), and two connector links (14)	Six connector pins (15)	a. Coat with grease (LO 5-2420-222-12). b. Place in position.
58. Six spool devises (7) and six connector - pins (15)	Six new cotter pins (16)	a. Place in position. b. Using long roundnose pliers, bend ends back.

BACKHOE CONTROL VALVE LEVERS AND LINKAGE (SERIAL NUMBERS 235786 THRU 235999 ONLY) - CONTINUED

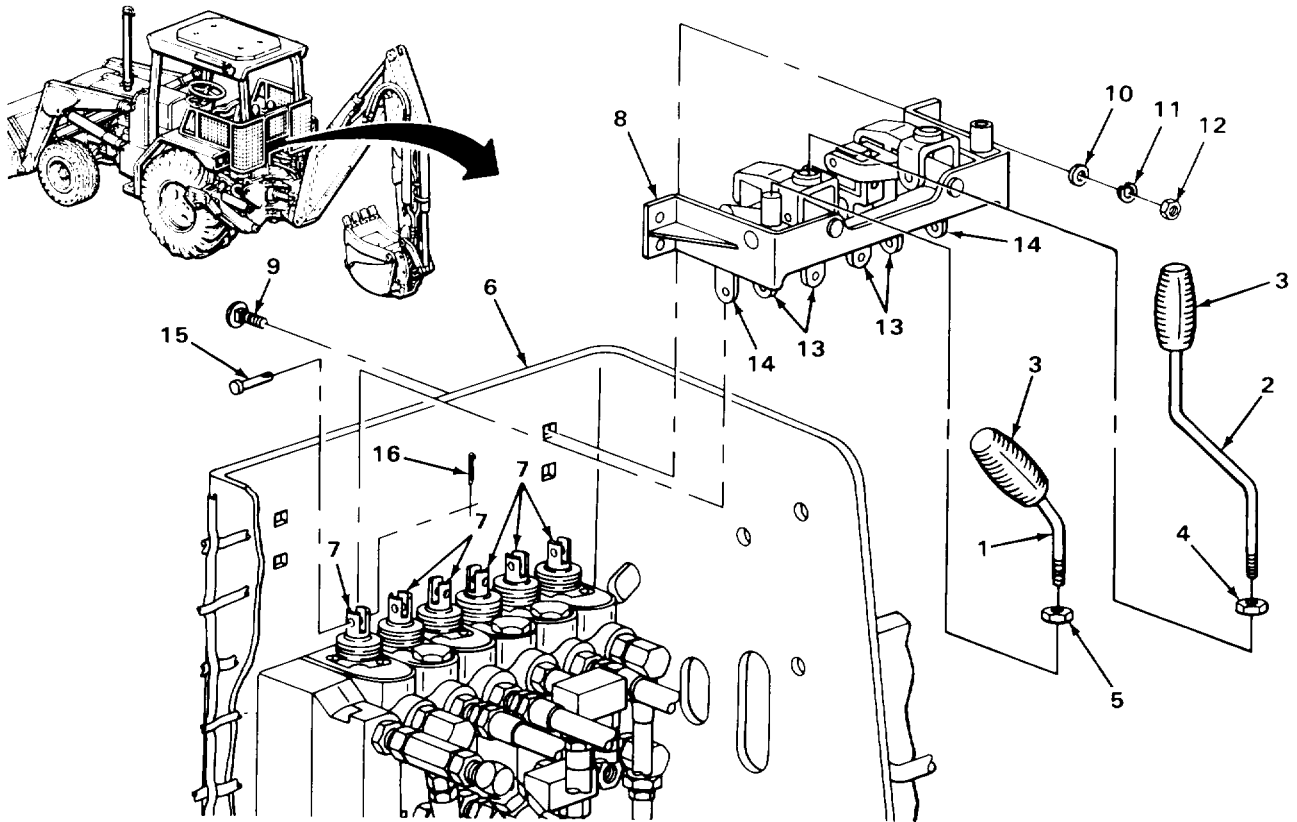

NOTE

FOLLOW-ON MAINTENANCE: Install backhoe valve box cover (page 2-1157).

TASK ENDS HERE

TA243362

BACKHOE CONTROL VALVE LEVERS AND LINKAGE (SERIAL NUMBERS 319995 THRU 342573 ONLY)

This task covers:

- a. Removal (page 2-1314)
- b. Disassembly (page 2-1315)
- c. Cleaning (page 2-1318)
- d. Inspection/Replacement (page 2-1319)
- e. Repair (page 2-1319)
- f. Assembly (page 2-1320)
- g. Installation (page 2-1322)

INITIAL SETUP:

Tools

- Extension, 1/2-inch drive, 10-inch
- Hammer, ball-peen, 1-pound head
- Hammer, plastic-faced
- Handle, ratchet, 1/2-inch drive
- Pliers, long roundnose
- Pliers, snapping
- Punch, straight drive-pin, 1/4-inch
- Socket, 1/2-inch drive, 1/2-inch
- Socket, 1/2-inch drive, 9/16-inch
- Threading set, screw
- Vise, machinist's
- Wrench, box, 1/2-inch

Materials/Parts

- Detergent, GP (item 7, Appendix C)
- Grease (LO 5-2420-222-12)
- Lockwasher, mounting frame screw (four required)

Materials/Parts - Continued

- Nut, special, connector link screw (four required)
- Pin, cotter, connector link pin (six required)
- Pin, cotter, pivot shaft (two required)
- Rags, wiping (item 21, Appendix C)
- Solvent, drycleaning (item 28, Appendix C)

Personnel Required

One

Equipment Condition

Backhoe valve box cover removed (page 2-1157)

LOCATION	ITEM	ACTION	REMARKS
----------	------	--------	---------

REMOVAL

1.	Six spool devises (1) and six connector pins (2)	Six cotter pins (3)	a. Using long roundnose pliers, straighten ends and take out. b. Get rid of.
2.	Six spool devises (1), connector links (4), and four connector links (5)	Six connector pins (2)	Take out.

BACKHOE CONTROL VALVE LEVERS AND LINKAGE (SERIAL NUMBERS 319995 THRU 342573 ONLY) - CONTINUED

LOCATION	ITEM	ACTION	REMARKS
3.	Mounting frame (6) and backhoe valve box (7)	Four bolts (8), washers (9), lock-washers (10), and nuts (11)	a. Using 9/16-inch, 1/2-inch drive socket, 10-inch extension, and ratchet handle, unscrew and take apart. b. Get rid of lockwashers (10).
4.	Backhoe valve box (7) and six spool devises (1)	Mounting frame (6) with assembled parts	Take off.

DISASSEMBLY

5.	Two control levers (12)	Two nuts (13)	Unscrew and take off.
6.	Two four way levers (14)	Two nuts (15)	Unscrew and take off.

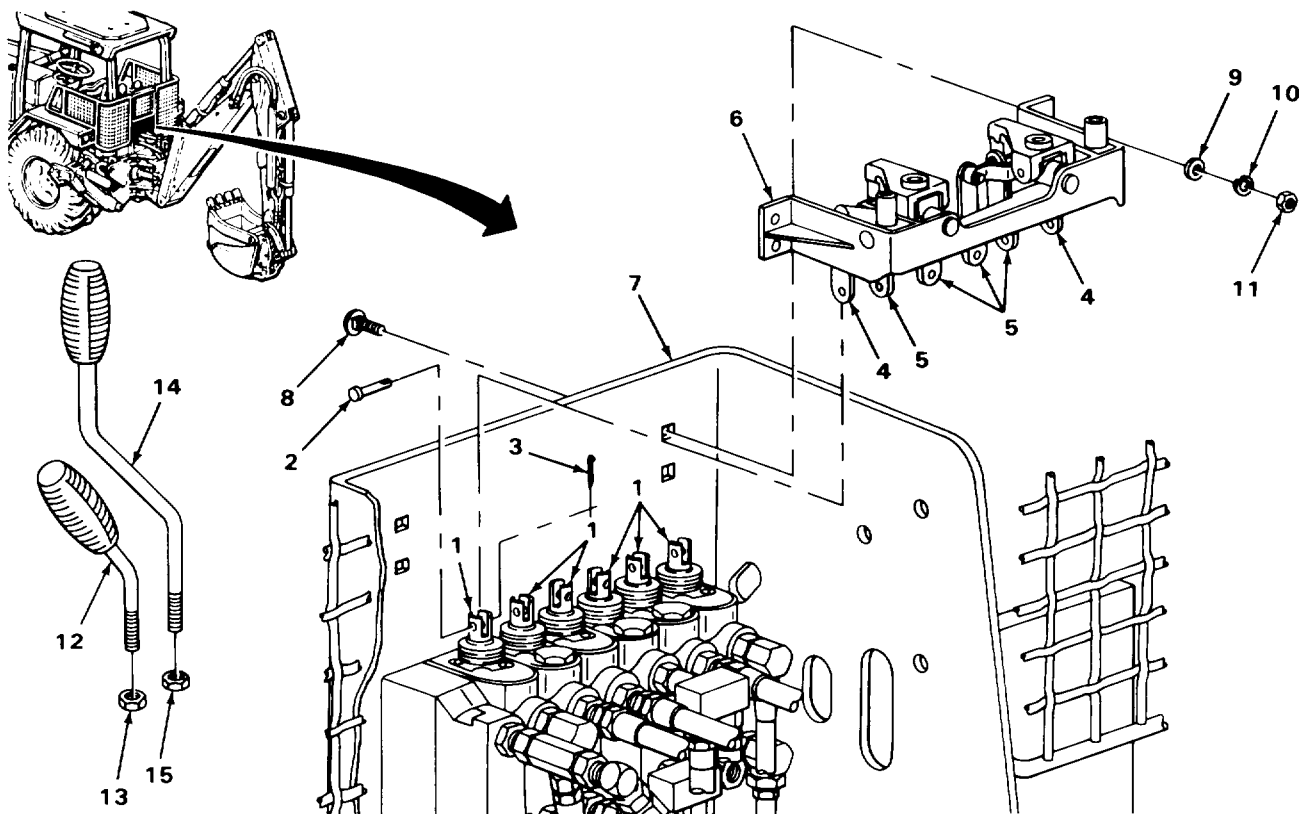

TA243363

BACKHOE CONTROL VALVE LEVERS AND LINKAGE (SERIAL NUMBERS 31995 THRU 342573 ONLY) - CONTINUED

LOCATION	ITEM	ACTION	REMARKS
DISASSEMBLY - CONTINUED			
7.	Two control levers (1) and two four way levers (2)	Four hand lever grips (3)	Twist off.
NOTE			
Linkage for both four way control levers is disassembled the same way. Backhoe bucket control lever linkage is shown. Repeat steps 8 thru 16 for backhoe boom control lever linkage.			
8.	Pivot shaft (4) and mounting frame (5)	Two rings (6)	a. Place mounting frame (5) in machinist's vise. b. Using snapping pliers, take off.
9.	Mounting frame (5), pivot link (7), and three washers (8)	Pivot shaft (4)	Using 1-pound head ball-peen hammer and 1/4-inch straight drive-pin punch, tap out.
10.	Mounting frame (5)	Pivot link (7) with assembled parts and three washers (8)	a. Take out. b. Take mounting frame (5) out of machinist's vise.
11.	Pivot link (7) and action link (9)	Groove pin (10)	a. Place pivot link (7) in machinist's vise. b. Using 1-pound head ball-peen hammer and 1/4-inch straight drive-pin punch, tap out.
12.	Pivot link(7)	Action link (9) with assembled parts	a. Take off. b. Take pivot link (7) out of machinist's vise.
13.	Action link (9) and connector link (11)	Screw (12) and special nut (13)	a. Using 1/2-inch, 1/2-inch drive socket, ratchet handle, and 1/2-inch box wrench, unscrew and take apart. b. Get rid of special nut (13).
14.	Action link (9)	Connector link (11) and special washer (14)	Take off.

BACKHOE CONTROL VALVE LEVERS AND LINKAGE (SERIAL NUMBERS 319995 THRU 342573 ONLY) - CONTINUED

LOCATION	ITEM	ACTION	REMARKS
15. Pivot link (7) and connector link (15)	Screw (16) and special nut (17)	a. Using 1/2-inch, 1/2-inch drive socket, ratchet handle, and 1/2-inch box wrench, unscrew and take apart. b. Get rid of special nut (17).	
16. Pivot link(9)	Connector link (15)	a. Take off. b. Repeat steps 8 thru 16 for backhoe boom control lever linkage.	

NOTE

Linkage for both stabilizer control levers is disassembled the same way. Left stabilizer control lever linkage is shown. Repeat steps 17 thru 21 for right stabilizer control lever linkage.

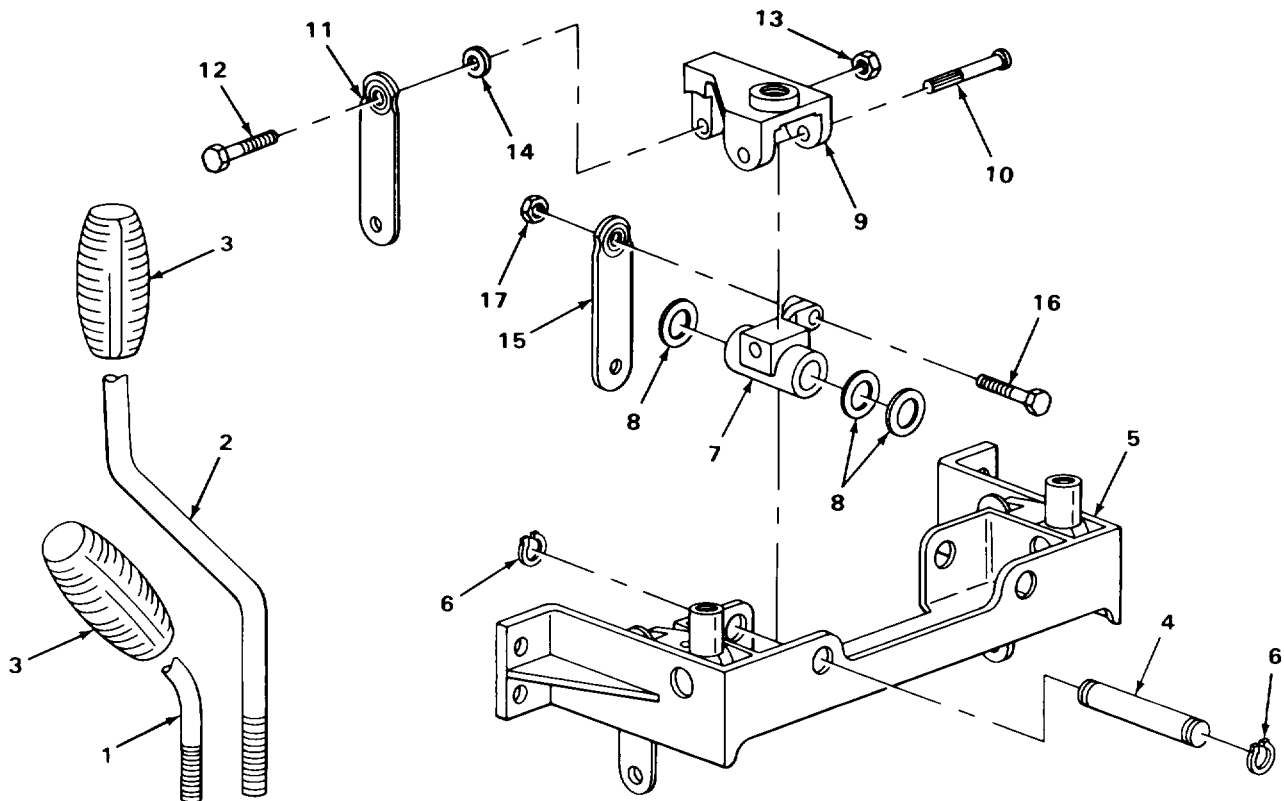

TA243364

BACKHOE CONTROL VALVE LEVERS AND LINKAGE (SERIAL NUMBERS 319995 THRU 342573 ONLY) - CONTINUED

LOCATION	ITEM	ACTION REMARKS
DISASSEMBLY - CONTINUED		
17.	Pivot shaft (1) and handle mount (2)	Cotter pin (3) a. Using long roundnose pliers, straighten ends and take out. b. Get rid of.
18.	Handle mount (2) and mounting frame (4)	Pivot shaft (1) Using 1-pound head ball-peen hammer and 1/4-inch straight drive-pin punch, tap out.
19.	Mounting frame (4)	Handle mount (2) with assembled parts Take out.
20.	Handle mount (2) and connector link (5)	Spring pin (6) a. Place handle mount (2) in machinist's b. Using 1-pound head ball-peen hammer and 1/4-inch straight drive-pin punch, tap out.
21.	Handle mount (2)	Connector link (5) a. Take off. b. Take handle mount (2) out of machinist's vise. c. Repeat steps 17 thru 21 for right stabilizer control lever linkage.

CLEANING
NOTE

For more information on how to clean parts, go to **General Maintenance Instructions (page 2-137)**.

WARNING

Drycleaning solvent P-D-680 is toxic and flammable. Wear protective goggles and gloves and use only in a well ventilated area. Avoid contact with skin, eyes, and clothes and don't breathe vapors. Do not use near open flame or excessive heat. The flashpoint is 100°F to 138°F (38° to 59°C). If you become dizzy while using cleaning solvent, get fresh air immediately and get medical aid. If contact with eyes is made, wash your eyes with water and get medical aid immediately.

22.	All metal parts	a. Clean in drycleaning solvent. b. Using clean, dry rags, wipe dry.
-----	-----------------	---

BACKHOE CONTROL VALVE LEVERS AND LINKAGE (SERIAL NUMBERS 31995 THRU 342573 ONLY) - CONTINUED

LOCATION	ITEM	ACTION	REMARKS
23.	All rubber parts	a. Clean in solution of detergent and water. b. Using clean, dry rags, wipe dry.	

INSPECTION/REPLACEMENT

NOTE

For more information on how to inspect parts, go to **General Maintenance Instructions (page 2-137)**.

Replace defective parts which cannot be repaired.

24.	All rubber parts	Look for cracks, breaks, and tears.
25.	All metal parts	Look for cracks, breaks, and abnormal bends.
26.	All threaded parts	Look for damaged threads.

REPAIR

27.	All threaded parts except hardware	If threads are damaged, using screw threading set, restore threads.
-----	------------------------------------	---

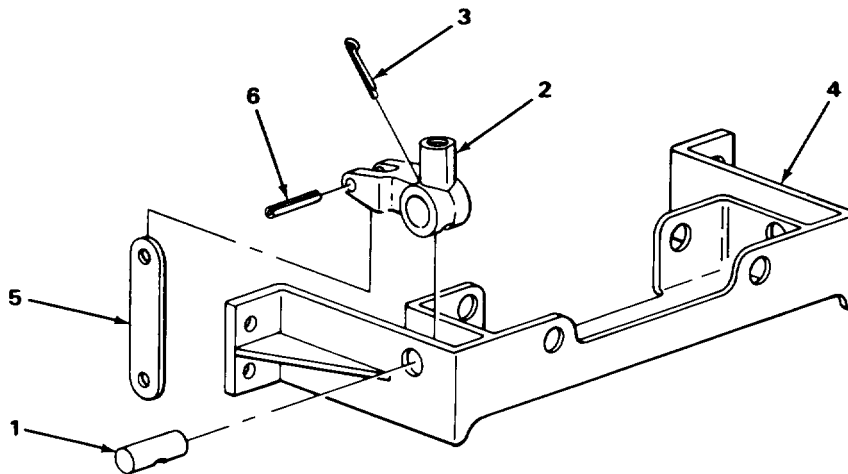

TA243367

BACKHOE CONTROL VALVE LEVERS AND LINKAGE (SERIAL NUMBERS 319995 THRU 342573 ONLY) - CONTINUED

LOCATION	ITEM	ACTION	REMARKS
ASSEMBLY			
NOTE			
Linkage for both stabilizer control levers is assembled the same way. Left stabilizer control lever linkage is shown. Repeat steps 28 thru 32 for right stabilizer control lever linkage.			
28.	Handle mount (1) Connector link (2)	a. Place handle mount (1) in machinist's vise. b. Coat with grease. c. Place in position.	
29.	Handle mount (1) Spring pin (3) and connector link (2)	a. Using 1-pound head ball-peen hammer and 1/4-inch straight drive-pin punch, tap in. b. Take handle mount (1) out of machinist's vise.	
30.	Mounting frame (4) Handle mount (1) with assembled parts	a. Coat with grease. b. Place in position.	
31.	Mounting frame (4) and handle mount (1)	Pivot shaft (5) a. Aline holes in handle mount (1) and shaft (5). b. Push into position.	
32.	Handle mount (1) and pivot shaft (5)	New cotter pin (6) a. Place in position. b. Using long roundnose pliers, bend ends back. c. Repeat steps 28 thru 32 for right stabilizer control lever linkage.	

NOTE

Linkage for both four way control levers is assembled the same way. Backhoe bucket control lever linkage is shown. Repeat steps 33 thru 41 for backhoe boom control lever linkage.

33.	Pivot link (7) Connector link (8)	a. Coat with grease. b. Place in position.	
34.	Pivot link (7) and connector link (8)	Screw (9) and new special nut (10)	Screw together and tighten using 1/2-inch, 1/2-inch drive socket, ratchet handle, and 1/2-inch box wrench.

BACKHOE CONTROL VALVE LEVERS AND LINKAGE (SERIAL NUMBERS 31995 THRU 342573 ONLY) - CONTINUED

LOCATION	ITEM	ACTION	REMARKS
35. Action link (11)	Connector link (12) and special washer (13)	a. Coat with grease. b. Place in position.	
36. Action link (11) and connector link (12)	Screw (14) and new special nut (15)	Screw together and tighten using 1/2-inch, 1/2-inch drive socket, ratchet handle, and 1/2-inch box wrench.	
37. Pivot link (7)	Action link (11) with assembled parts	a. Coat with grease. b. Place in position.	
38. Pivot link (7) and action link (11)	Grooved pin (16)	Using 1-pound head ball-peen hammer, tap in.	

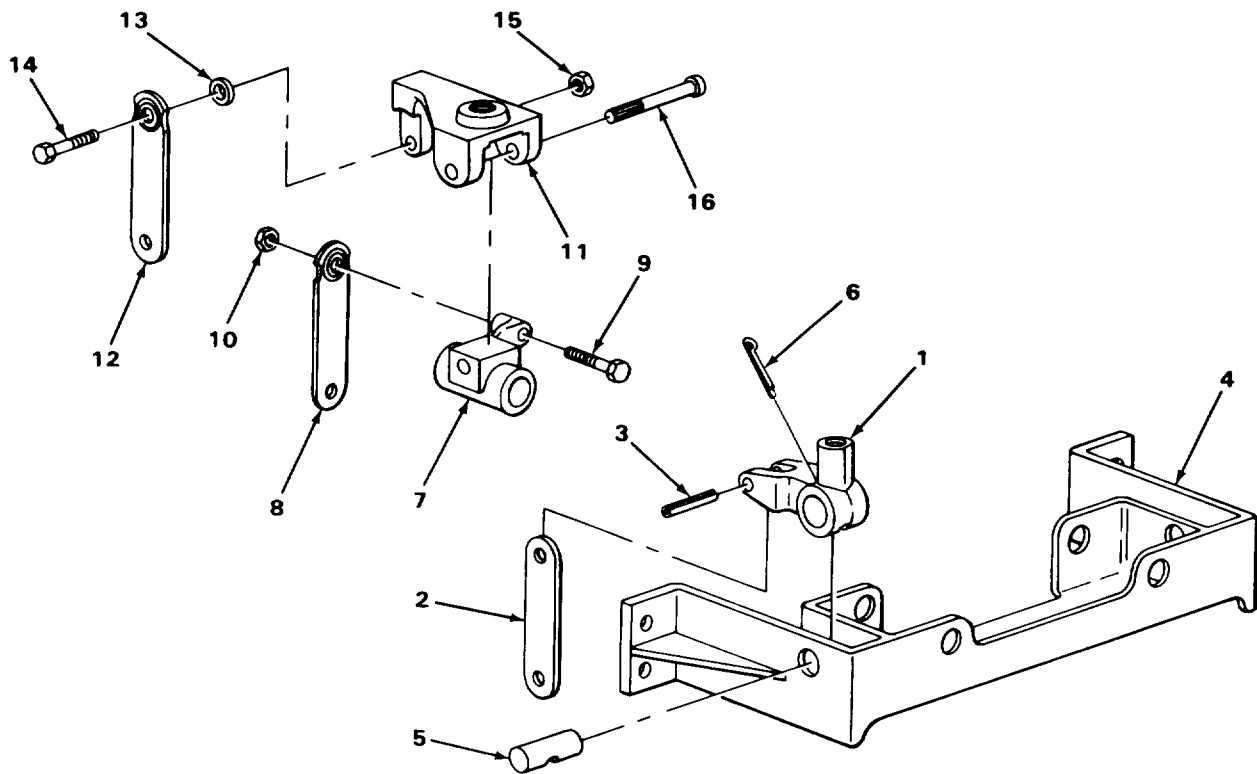

TA243365

BACKHOE CONTROL VALVE LEVERS AND LINKAGE (SERIAL NUMBERS 31995 THRU 342573 ONLY) - CONTINUED

LOCATION	ITEM	ACTION REMARKS
ASSEMBLY - CONTINUED		
39. Mounting frame (1)	Pivot link (2) with assembled parts and three washers (3)	a. Place mounting frame (1) in machinist's vise. b. Coat with grease. c. Place in position.
40. Mounting frame (1), pivot link (2), and three washers (3)	Pivot shaft (4)	Using plastic-faced hammer, tap in.
41. Mounting frame (1) and pivot shaft (4)	Two rings (5)	a. Using snapping pliers, place in position. b. Take mounting frame (1) out of machinist's vise. c. Repeat steps 33 thru 41 for backhoe boom control lever linkage.
42. Two control levers (6) and two four way levers (7)	Four hand lever grips (8)	Twist on.
43. Two control levers (6)	Two nuts (9)	Screw on all the way.
44. Two four way levers (7)	Two nuts (10)	Screw on all the way.
INSTALLATION		
45. Backhoe valve box (11) and six spool devises (12)	Mounting frame (1) with assembled parts	Place in position.
46. Mounting frame (1) and backhoe valve box (11)	Four bolts (13), washers (14), new lockwashers (15), and nuts (16)	Screw together and tighten using 9/16- inch, 1/2-inch drive socket, 10-inch extension, and ratchet handle.
47. Six spool devises (12), two connector links (17), and four connector links (18)	Six connector pins (19)	a. Coat with grease. b. Place in position.

BACKHOE CONTROL VALVE LEVERS AND LINKAGE (SERIAL NUMBERS 31995 THRU 342573 ONLY) - CONTINUED

LOCATION	ITEM	ACTION	REMARKS
48. Six spool clevises (12) and six connector pins (19)	Six new cotter pins (20)	a. Place in position. b. Using long roundnose pliers, bend ends back.	

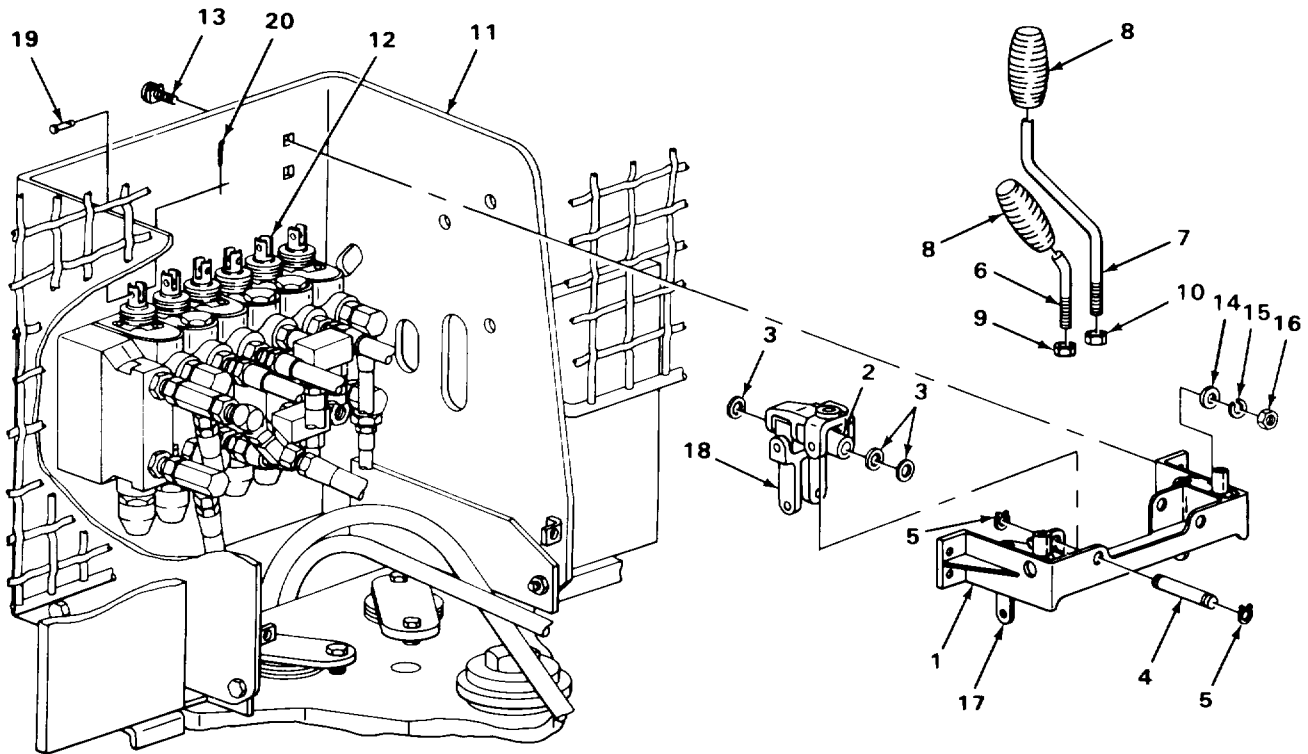

NOTE

FOLLOW-ON MAINTENANCE: Install backhoe valve box cover (page 2-1157).

TASK ENDS HERE

TA243366

LOADER CONTROL VALVE HANDLE AND LINKAGE

This task covers:

- | | |
|---|-------------------------------|
| a. Removal (page 2-1324) | e. Repair (page 2-1330) |
| b. Disassembly (page 2-1326) | f. Assembly (page 2-1330) |
| c. Cleaning (page 2-1328) | g. Installation (page 2-1334) |
| d. Inspection/Replacement (page 2-1329) | h. Adjustment (page 2-1334) |

INITIAL SETUP:

Tools

- Gage, thickness
- Hammer, ball-peen, 1-pound head
- Pliers, slip-joint
- Punch, straight drive-pin, 1/4-inch
- Punch, straight drive-pin, 1/2-inch
- Threading set, screw
- Vise, machinist's
- Wrench, box, 9/16-inch
- Wrench, open-end, 3/4-inch (two required)
- Wrench, open-end, 15/16-inch

Materials/Parts

- Detergent, GP (item 7, Appendix C)
- Grease (LO 5-2420-222-12)
- Lockwasher, control pivot screw (two required)

Materials/Parts - Continued

- Pin, cotter, connector pin (two required)
- Pin, cotter, handle mount pin
- Rags, wiping (item 21, Appendix C)
- Solvent, drycleaning (item 28, Appendix C)
- Washer, pivot block-to-pivot control (as required)

Personnel Required

One

Equipment Condition

Loader control box door removed (page 2-1167)

LOCATION	ITEM	ACTION	REMARKS
REMOVAL			
1.	Loader backhoe	Right platform	Remove (page 2-2079).
2.	Handle (1) and handle mount (2)	Nut (3)	Using 15/16-inch open-end wrench, loosen.
3.	Handle mount (2)	Handle (1) with assembled parts	<ul style="list-style-type: none"> a. Note relative position for proper placement during installation. b. Unscrew and take out.

LOADER CONTROL VALVE HANDLE AND LINKAGE - CONTINUED

LOCATION	ITEM	ACTION	REMARKS
4.	Two spool devices (4) and two connector pins (5)	Two cotter pins (6)	a. Using slip-joint pliers, straighten ends and take out. b. Get rid of.
5.	Boom control rod (7), bucket control rod (8), and two spool devices (4)	Two connector pins (5)	Take out.
6.	Loader control box (9) and control control pivot (10)	Two screws (11) and lockwashers (12)	a. Using 9/16-inch box wrench, unscrew and take out. b. Get rid of lockwashers (12).
7.	Loader control box (9) and two spool devices (4)	Control pivot (10) with assembled parts	Take off.

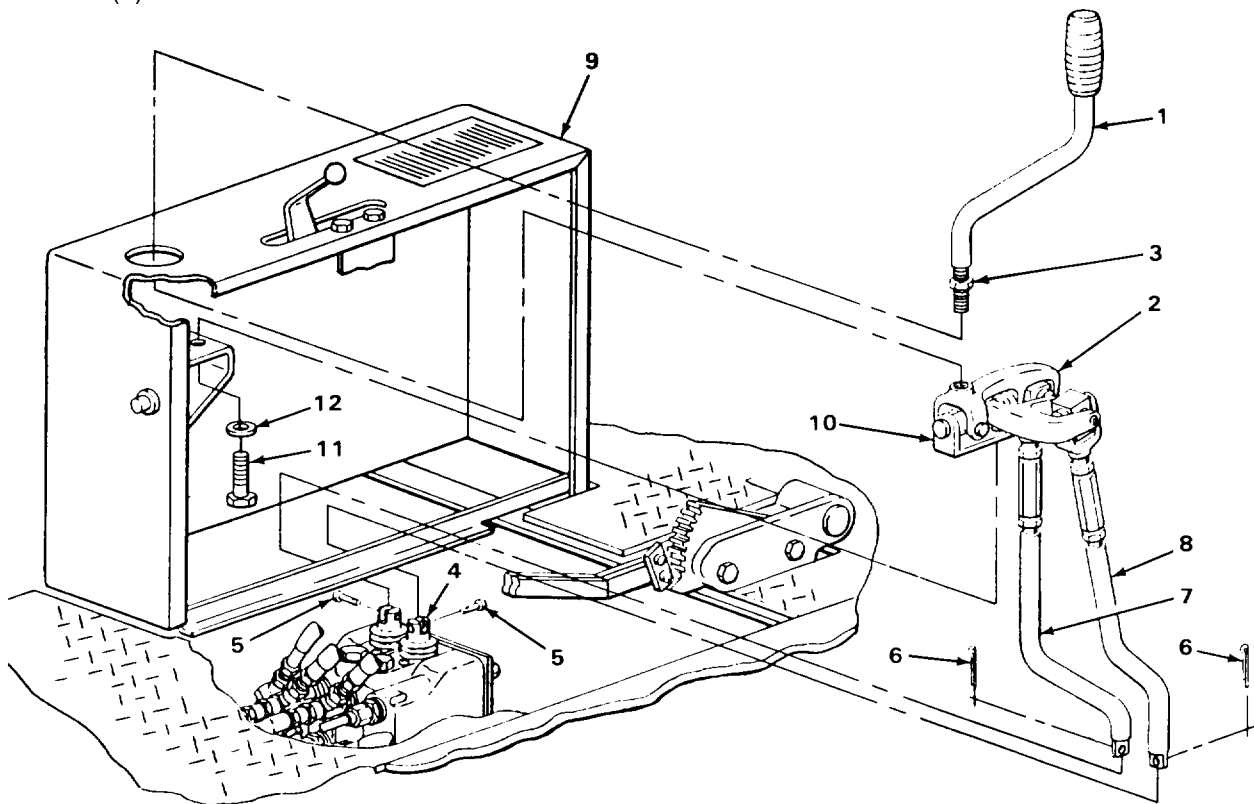

TA243368

LOADER CONTROL VALVE HANDLE AND LINKAGE - CONTINUED

LOCATION	ITEM	ACTION REMARKS
DISASSEMBLY		
8. Handle (1)	Nut (2)	Unscrew and take off.
9.	Handle grip (3)	Twist off.
10. Handle mount (4) and pivot pin (5)	Cotter pin (6)	a. Using slip-joint pliers, straighten ends and take out. b. Get rid of.
11. Handle mount (4) and pivot block (7)	Pivot pin (5)	Take out.
12. Handle mount (4)	Pivot block (7) with assembled parts	Take off.
NOTE		
Pivot block end play is determined by amount of washers between pivot block and control block. There may be no washers, one washer, or several washers between pivot block and control block.		
13. Pivot block (7), control pivot (8), and washers (9), if present	Pivot shaft (10)	a. Place pivot block (7) in machinist's vise. b. Using 1-pound head ball-peen hammer and 1/2-inch straight drive-pin punch, drive out.
14. Pivot block (7)	Control pivot (8) and washers (9), if present	a. If present, note quantity and relative position of washers (9) for proper placement during assembly. b. Take off.
15. Pivot block (7) and universal block (11)	Spring pin (12)	Using 1/4-inch straight drive-pin punch and 1-pound head ball-peen hammer, tap out.
16. Pivot block (7)	Universal block (11) with assembled parts	a. Take off. b. Take pivot block (7) out of machinist's vise.
17. Handle mount (4) and universal block (13)	Spring pin (14)	a. Place handle mount (4) in machinist's vise. b. Using 1/4-inch straight drive-pin punch and 1-pound head ball-peen hammer, tap out.

LOADER CONTROL VALVE HANDLE AND LINKAGE - CONTINUED

LOCATION	ITEM	ACTION	REMARKS
18. Handle mount (4)	Universal block (13) with assembled parts	a. Take off. b. Take handle mount (4) out of machinist's vise.	

NOTE

Boom control rod and bucket control rod are disassembled the same way. Bucket control rod is shown. Repeat steps 19 thru 26 for boom control rod.

19. Connector link (15) universal block (11)	Spring pin (16)	a. Place connector link (15) in machinist's vise. b. Using 1/4-inch straight drive-pin punch and 1-pound head ball-peen hammer, tap out.	
---	-----------------	--	--

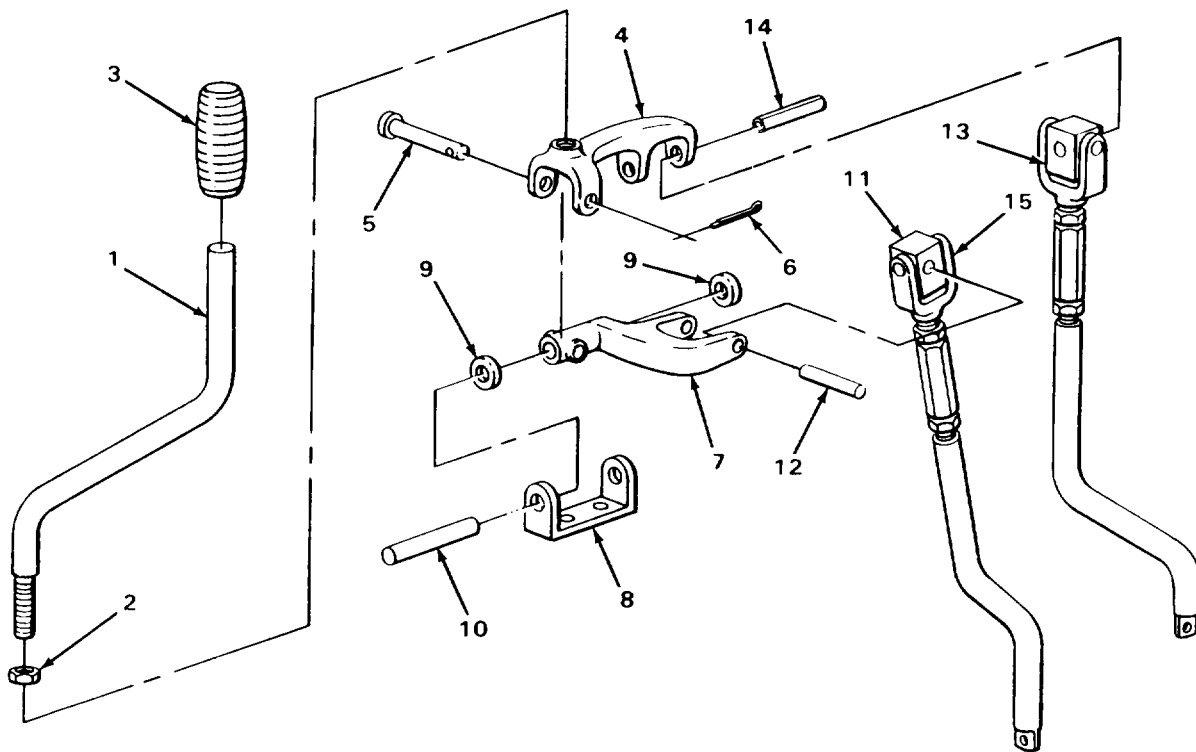

TA243369

LOADER CONTROL VALVE HANDLE AND LINKAGE - CONTINUED

LOCATION	ITEM	ACTION	REMARKS
DISASSEMBLY - CONTINUED			
20.	Connector link (1)	Universal block (2)	Take off.
<u>CAUTION</u>			
Connector links and upper nuts are right-hand thread. Boom and bucket control rods and lower nuts are left-hand thread. Turn buckles are right-hand thread on one end and left-hand thread on the other end. Turning parts in the wrong direction or mixing up parts will cause damage to threads.			
21.	Connector link (1) and turnbuckle (3)	Nut (4)	<ol style="list-style-type: none"> Using two 3/4-inch open-end wrenches, loosen. Take connector link (1) out of machinist's vise.
22.	Turnbuckle (3)	Connector link (1) with assembled nut (4)	<ol style="list-style-type: none"> Place turnbuckle (3) in machinist's vise. Note number of exposed threads and relative position for proper placement during assembly. Unscrew and take out.
23.	Connector link (1)	Nut (4)	Unscrew and take off.
24.	Turnbuckle (3) and bucket control rod (5)	Nut (6)	Using 3/4-inch open-end wrench, loosen.
25.	Turnbuckle (3)	Bucket control rod (5) with assembled nut (6)	<ol style="list-style-type: none"> Note number of exposed threads for proper placement during assembly. Unscrew and take out. Take turnbuckle (3) out of machinist's vise.
26.	Bucket control rod (5)	Nut (6)	<ol style="list-style-type: none"> Unscrew and take off. Repeat steps 19 thru 26 for boom control rod.

CLEANING

NOTE

For more information on how to clean parts, go to **General Maintenance Instructions (page 2-137)**.

LOADER CONTROL VALVE HANDLE AND LINKAGE - CONTINUED

LOCATION	ITEM	ACTION	REMARKS
27.	Handle grip (7)	a. Clean in solution of detergent and water. b. Rinse in clean water. c. Using clean, dry rags, wipe dry.	

WARNING

Drycleaning solvent P-D-680 is toxic and flammable. Wear protective goggles and gloves and use only in a well ventilated area. Avoid contact with skin, eyes, and clothes and don't breathe vapors. Do not use near open flame or excessive heat. The flashpoint is 100°F to 1380F (380 to 590C). If you become dizzy while using cleaning solvent, get fresh air immediately and get medical aid. If contact with eyes is made, wash your eyes with water and get medical aid immediately.

28.	All metal parts	a. Clean in drycleaning solvent. b. Using clean, dry rags, wipe dry.	
-----	-----------------	---	--

INSPECTION/REPLACEMENT

NOTE

For more information on how to inspect parts, go to General Maintenance Instructions (page 2-137).

Replace defective parts which cannot be repaired.

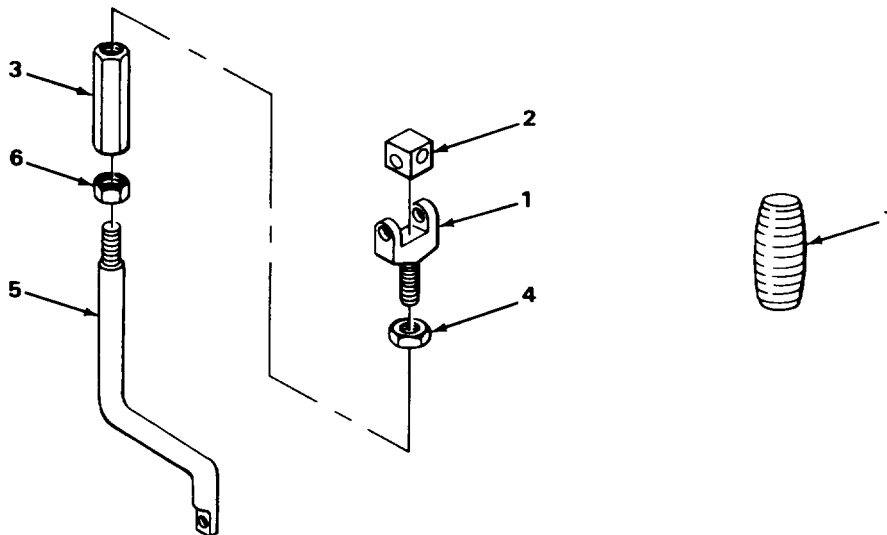

TA243370

LOADER CONTROL VALVE HANDLE AND LINKAGE - CONTINUED

LOCATION	ITEM	ACTION REMARKS
INSPECTION/REPLACEMENT - CONTINUED		
29.	Handle grip (1)	Look for cracks, breaks, and tears.
30.	All metal parts	Look for cracks, breaks, and abnormal bends.
31.	All threaded parts	Look for damaged threads.
REPAIR		
32.	All threaded parts except hardware	If threads are damaged, using screw threading set, restore threads.

ASSEMBLY

NOTE

Boom control rod and bucket control rod are assembled the same way. Bucket control rod is shown. Repeat steps 33 thru 40 for boom control rod.

CAUTION

Connector links and upper nuts are right-hand thread. Boom and bucket control rods and lower nuts are left-hand thread. Turn buckles are right-hand thread on one end and left-hand thread on the other end. Turning parts in the wrong direction or mixing up parts will cause damage to threads.

33.	Bucket control rod (2)	Nut (3)	Screw on all the way.
34.	Turnbuckle (4)	Bucket control rod (2) with assembled nut (3)	<ol style="list-style-type: none"> Place turnbuckle (4) in machinist's vise. Screw in until same number of exposed threads are showing as noted during disassembly.
35.	Turnbuckle (4) and bucket control rod (2)	Nut (3)	Using 3/4-inch open-end wrench, tighten until seated against turnbuckle (4).
36.	Connector link (5)	Nut (6)	Screw on all the way.
37.	Turnbuckle (4)	Connector link (5) with assembled nuts (6)	Screw in until same number of exposed threads are showing and in same relative position as noted during disassembly.

LOADER CONTROL VALVE HANDLE AND LINKAGE - CONTINUED

LOCATION	ITEM	ACTION REMARKS
38. Turnbuckle (4) and control link (5)	Nut (6)	a. Using 3/4-inch open-end wrench, tighten until seated against turnbuckle (4). b. Take turnbuckle (4) out of machinist's vise.
39. Connector link (5)	Universal block (7)	a. Place connector link (5) in machinist's vise. b. Coat with grease. c. Place in position.
40. Connector link (5) and universal block (7)	Spring pin (8)	a. Using 1/4-inch straight drive-pin punch and 1-pound head ball-peen hammer, tap in. b. Take connector link (5) out of machinist's vise. c. Repeat steps 33 thru 40 for boom control rod.

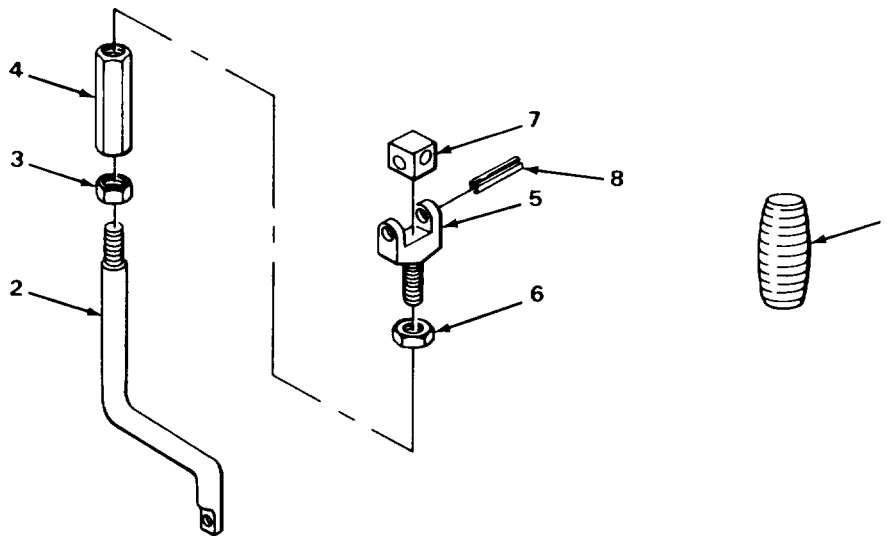

TA243371

LOADER CONTROL VALVE HANDLE AND LINKAGE - CONTINUED

LOCATION	ITEM	ACTION REMARKS
ASSEMBLY - CONTINUED		
41. Handle mount (1)	Universal block (2)	a. Place handle mount (1) in machinist's vise. b. Place in position.
42. Handle mount (1) and universal block (2)	Spring pin (3)	a. Using 1/4-inch straight drive-pin punch and 1-pound head ball-peen hammer, tap in. b. Take handle mount (1) out of machinist's vise.
43. Pivot block (4)	Control pivot (5) and washers (6),	a. Coat with grease. b. Place pivot block (4) in machinist's if present vise. c. Using same quantity of washers (6) in same position as noted during assembly, place in position.
44. Control pivot (5), pivot block (4), and washers (6), if present	Pivot shaft (7)	Using 1/2-inch straight drive-pin punch and 1-pound head ball-peen hammer, tap in.
45. Control pivot (5)	Pivot block (4)	Using thickness gage, measure end play. End play must be 0.040-inch (1 mm) or less.
NOTE		
If end play measured in step 45 is correct, skip steps 46 and 47.		
46. Control pivot (5), pivot block (4), and washers (6), if present	Pivot shaft (7)	Using 1/2-inch straight drive-pin punch and 1-pound head ball-peen hammer, drive out.
47. Control pivot (5) and pivot block (4)	Washers (6)	a. Add enough to get proper end play. Each washer is 0.036-inch (0.91 mm) thick. b. Repeat steps 44 thru 47.
48. Pivot block (4)	Universal block (8) with assembled parts	Place in position.

LOADER CONTROL VALVE HANDLE AND LINKAGE - CONTINUED

LOCATION	ITEM	ACTION REMARKS
49. Pivot block (5) and universal block (8)	Spring pin (9)	a. Using 1/4-inch straight drive-pin punch and 1-pound head ball-peen hammer, tap in. b. Take pivot block (5) out of machinist's vise.
50. Handle mount (1)	Pivot block (4) with assembled parts	a. Coat with grease. b. Place in position.
51. Handle mount (1) and pivot block (4)	Pivot pin (10)	Place in position.
52. Handle mount (1) and pivot pin (10)	New cotter pin (11)	a. Place in position. b. Using slip-joint pliers, bend ends back.
53. Handle (12)	Handle grip (13)	Twist on.
54.	Nut (14)	Screw on all the way.

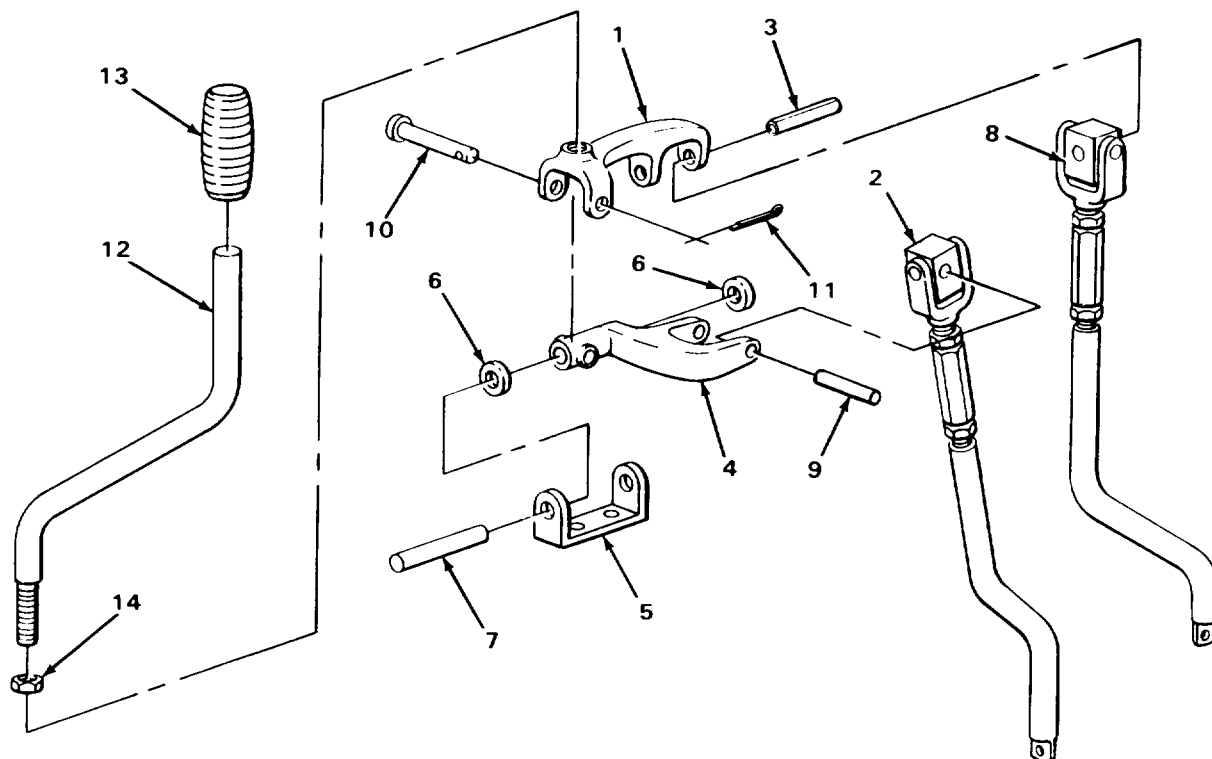

TA243372

LOADER CONTROL VALVE HANDLE AND LINKAGE - CONTINUED

LOCATION	ITEM	ACTION	REMARKS
INSTALLATION			
55. Loader control box (1) and two spool devises (2)	Control pivot (3) with assembled parts	Place in position.	
56. Loader control box (1) and control pivot (3)	Two screws (4) and new lockwashers (5)	Screw in and tighten using 9/16-inch box wrench.	
57. Boom control rod (6), bucket control rod (7), and two spool devise (2)	Two connector pins (8)	Place in position.	
58. Two spool devises (2) and two connector pins (8) back.	Two new cotter pins (9)	a. Place in position. b. Using slip-joint pliers, bend ends	
59. Handle mount (10) assembled parts	Handle (11) with during removal.	Screw in and tighten to position noted	
60. Handle mount (10) and handle (11)	Nut (12)	Using 15/16-inch open-end wrench, tighten until seated against handle mount (10).	
61.	Right platform	Install (page 2-1079).	
ADJUSTMENT			
62. Handle mount (10)	Handle (11)	Check for proper position. Handle must be in vertical position.	

NOTE

If handle is in vertical position, skip steps 63 thru 68.

If handle is not tilted to left or right, skip steps 63 thru 65.

CAUTION

Upper nut is right-hand thread. Lower nut is left-hand thread. Overtightening nuts may cause damage to parts.

LOADER CONTROL VALVE HANDLE AND LINKAGE - CONTINUED

LOCATION	ITEM	ACTION	REMARKS
63. Connector link (13), turnbuckle (14), and bucket control rod (7)	Two nuts (15 and 16)	Using two 3/4-inch open-end wrenches, loosen.	
64. Connector link (13) and bucket control rod (7)	Turnbuckle (14)	a. If handle (11) is tilted to right, using 3/4-inch open-end wrench, turn to lengthen assembly. b. If handle (11) is tilted to left, using 3/4-inch open-end wrench, turn to shorten assembly.	
65. Connector link (13), turnbuckle (14), and bucket control rod (7)	Two nuts (15 and 16)	a. Using two 3/4-inch open-end wrenches, tighten until seated against turnbuckle (14). b. Repeat steps 62 thru 65.	

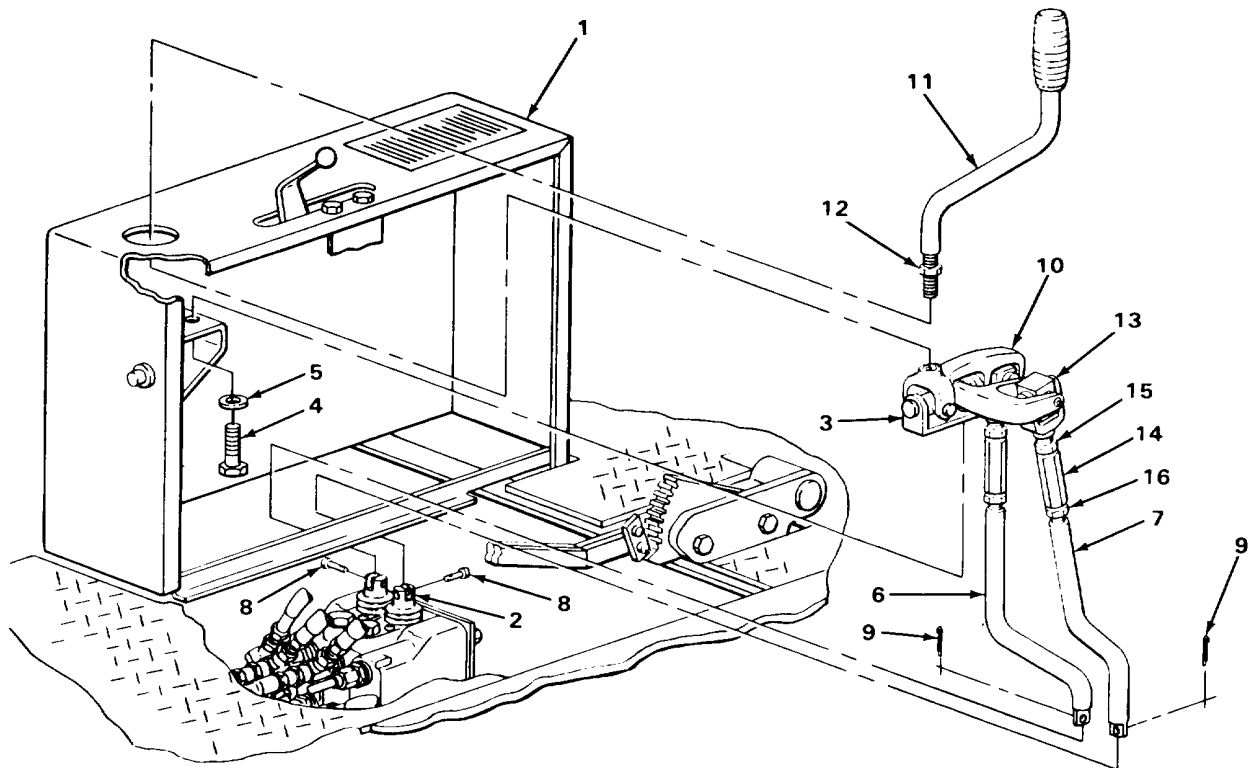

TA243373

LOADER CONTROL VALVE HANDLE AND LINKAGE - CONTINUED

LOCATION	ITEM	ACTION	REMARKS
ADJUSTMENT - CONTINUED			
NOTE			
If handle is not tilted to front or rear, skip steps 66 thru 68.			
<u>CAUTION</u>			
Upper nut is right-hand thread. Lower nut is left-hand thread. Overtightening nuts may cause damage to parts.			
66. Connector link (1), turnbuckle (2), and boom control rod (3)	Two nuts (4 and 5)		Using two 3/4-Inch open-end wrenches, loosen.
67. Connector link (1) and boom control rod (3)	Turnbuckle (2)	a. If handle (6) is tilted to front, using 3/4-inch open-end wrench, turn to lengthen assembly. b. If handle (6) is tilted to rear, using 3/4-inch open-end wrench, turn to shorten assembly.	
68. Connector link (1), turnbuckle (2), and boom control rod (3)	Two nuts (4 and 5)	a. Using two 3/4-inch open-end wrenches, tighten until seated against turnbuckle (2). b. Repeat steps 62 thru 68.	

LOADER CONTROL VALVE HANDLE AND LINKAGE - CONTINUED

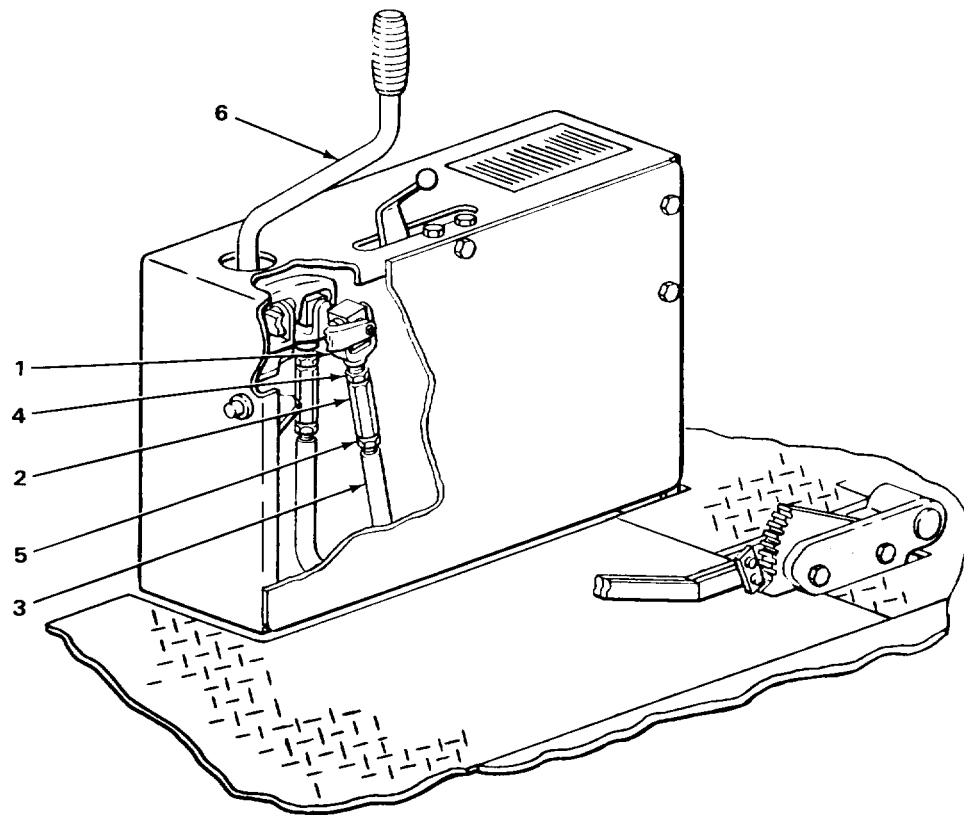

NOTE

FOLLOW-ON MAINTENANCE: Install loader control box door (page 2-1167).

TASK ENDS HERE

TA243374

HYDRAULIC PUMP-TO-HYDRAULIC OIL COOLER HOSE (SERIAL NUMBERS 319995 THRU 342573 - ONLY)

This task covers:

- a. Removal (page 2-1338)
- b. Cleaning (page 2-1339)
- c. Inspection/Replacement (page 2-1340)
- d. Installation (page 2-1340)

INITIAL SETUP:

Tools

- Pan, drain
- Screwdriver, flat-tip, 3/16-inch

Materials/Parts

- Detergent, GP (item 7, Appendix C)
- Rags, wiping (item 21, Appendix C)
- Solvent, drycleaning (item 28, Appendix C)
- Tags, marking (item 30, Appendix C)

Personnel Required

One

Equipment Condition

- 1. Loader bucket support installed (page 2-1830)
- 2. Hood removed (page 2-1025)

LOCATION	ITEM	ACTION	REMARKS
----------	------	--------	---------

REMOVAL

WARNING

Be careful when draining hot fluids. Wear gloves to protect your hands from hot parts and fluids or severe burns could result.

1. Hose (1)	Two clamps (2)	a. Place drain pan underneath. b. Using 3/16-inch flat-tip screwdriver, loosen.	
2. Oil cooler (3) and special adapter (4)	Hose (1) with two assembled clamps (2)	a. Pull off. b. Let fluid drain into drain pan. c. Get rid of drained fluid (page 2-137). d. Cap oil cooler (3) and adapter (4) (page 2-137). e. Tag (page 2-137).	
3. Hose (1)	Two clamps (2)	Take off.	

HYDRAULIC PUMP-TO-HYDRAULIC OIL COOLER HOSE (SERIAL NUMBERS 319995 THRU 342573 ONLY) - CONTINUED

LOCATION	ITEM	ACTION	REMARKS
----------	------	--------	---------

CLEANING

NOTE

For more information on how to clean parts, go to **General Maintenance Instructions (page 2-137)**.

- | | |
|-------------|---|
| 4. Hose (1) | <ul style="list-style-type: none"> a. Using clean rags dampened with solution of detergent and water, wipe clean. b. Using clean water, rinse. c. Using clean, dry rags, wipe dry. |
|-------------|---|

WARNING

Drycleaning solvent P-D-680 is toxic and flammable. Wear protective goggles and gloves and use only in a well ventilated area. Avoid contact with skin, eyes, and clothes and don't breathe vapors. Do not use near open flame or excessive heat. The flashpoint is 100°F to 138°F (38° to 59°C). If you become dizzy while using cleaning solvent, get fresh air immediately and get medical aid. If contact with eyes is made, wash your eyes with water and get medical aid immediately.

- | | | |
|----|----------------|---|
| 5. | Two clamps (2) | <ul style="list-style-type: none"> a. Clean in drycleaning solvent. b. Using clean, dry rags, wipe dry. |
|----|----------------|---|

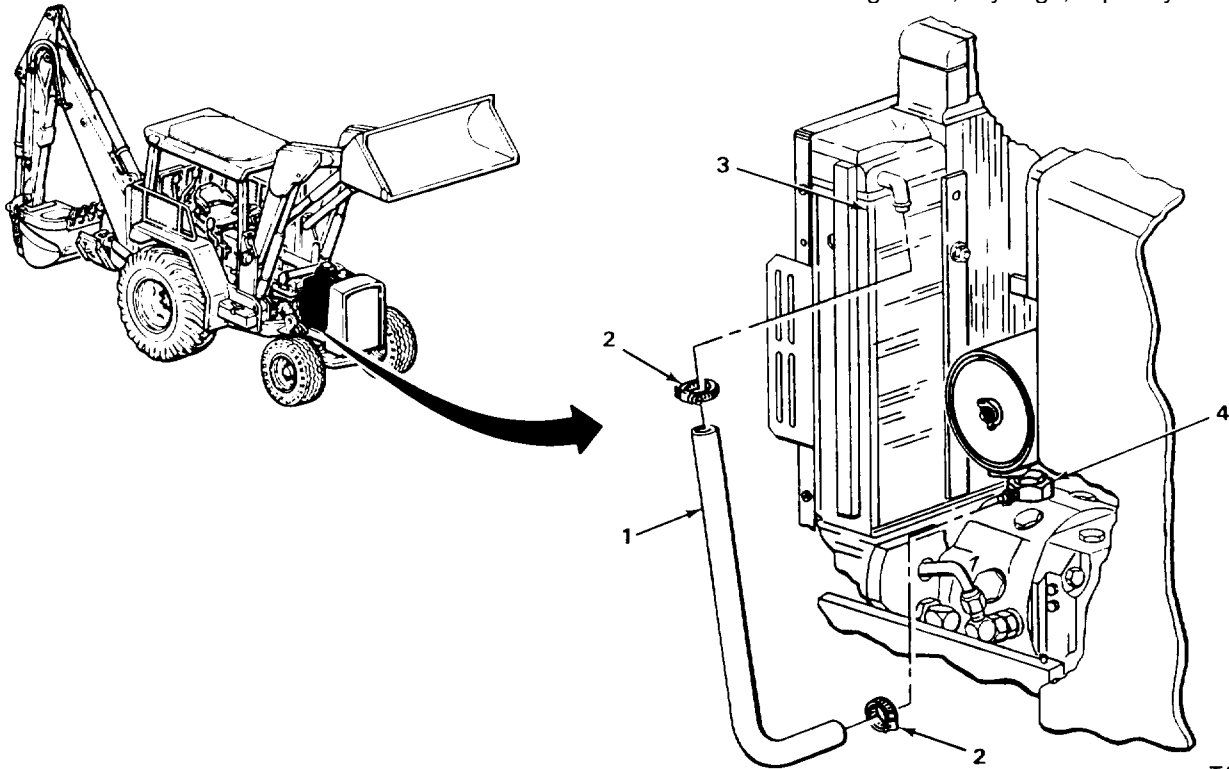

TA243375

HYDRAULIC PUMP-TO-HYDRAULIC OIL COOLER HOSE (SERIAL NUMBERS 319995 THRU 342573 ONLY) - CONTINUED

LOCATION	ITEM	ACTION	REMARKS
----------	------	--------	---------

INSPECTION/REPLACEMENT

NOTE

For more information on how to inspect parts, go to General Maintenance Instructions (page 2-137).

Replace defective parts as needed.

- | | | | |
|----|----------------|--|---|
| 6. | Hose (1) | | Look for cracks, breaks, and tears. |
| 7. | Two clamps (2) | | a. Look for cracks, breaks, and abnormal bends.
b. Look for damaged threads. |

INSTALLATION

NOTE

New hoses are manufactured to required length from bulk items. For more information on manufacturing new hoses, go to Appendix D.

- | | | | |
|---|---|--|--|
| 8. Hose (1) | Two clamps (2) | | Place in position. |
| 9. Oil cooler (3) and special adapter (4) | Hose (1) with two assembled clamps (2) | | a. Uncap oil cooler (3) and adapter (4).
b. Take off tag.
c. Push on. |
| 10. Hose (1) | Two clamps (2) | | Using 3/16-inch flat-tip screwdriver, tighten. |
| 11. Loader backhoe | Transmission | | Check fluid level and add proper amount and grade (TM 5-2420-222-10). |
| 12. | Engine | | Start and run at high idle (TM 5-2420-222-10). |
| 13. | Hydraulic pump-to-hydraulic oil cooler hose | | a. Check for leaks.
b. If leaking at any connection, tighten using 3/16-inch flat-tip screwdriver.
c. If leaking does not stop, shut down engine (TM 5-2420-222-10) and replace defective hose or clamp as outlined in this task.
d. If found leaking, repeat steps 11 thru 13. |

HYDRAULIC PUMP-TO-HYDRAULIC OIL COOLER HOSE (SERIAL NUMBERS 319995 THRU 342573 ONLY) - CONTINUED

LOCATION	ITEM	ACTION	REMARKS
14.	Engine	If still running, shut down (TM 5-2420-222-10).	

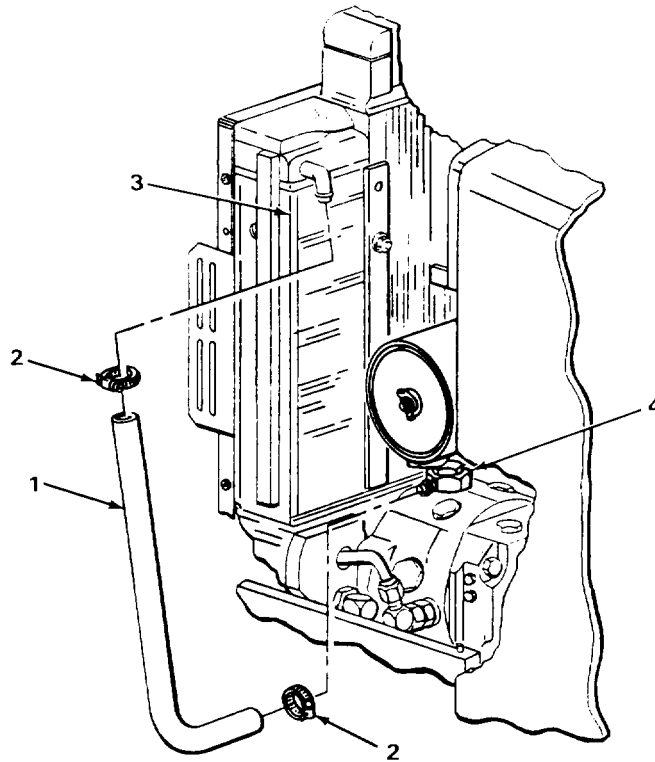

NOTE

FOLLOW-ON MAINTENANCE:

1. Install hood (page 2-1025).
2. Remove loader bucket support (page 2-1830).

TASK ENDS HERE

TA243376

HYDRAULIC PUMP-TO-HYDRAULIC OIL COOLER OIL LINE (SERIAL NUMBERS 235786 THRU 235999 ONLY)

This task covers:

- | | |
|---------------------------|---|
| a. Removal (page 2-1342) | c. Inspection/Replacement (page 2-1344) |
| b. Cleaning (page 2-1343) | d. Installation (page 2-1344) |

INITIAL SETUP:

<p>Tools</p> <p>Pan, drain Screwdriver, flat-tip, 3/16-inch</p> <p>Materials/Parts</p> <p>Detergent, GP (item 7, Appendix C) Rags, wiping (item 21, Appendix C) Solvent, drycleaning (item 28, Appendix C) Tags, marking (item 30, Appendix C)</p>	<p>Personnel Required</p> <p>One</p> <p>Equipment Condition</p> <ol style="list-style-type: none"> 1. Loader bucket support installed (page 2-1830) 2. Hood removed (page 2-1025)
--	---

LOCATION	ITEM	ACTION	REMARKS
----------	------	--------	---------

REMOVAL

WARNING

Be careful when draining hot fluids. Wear gloves to protect your hands from hot parts and fluids or severe burns could result.

<ol style="list-style-type: none"> 1. Hose (1) 2. Hose (3) 3. Two hoses Oil line (5) (1 and 3) 4. Hose (1) 5. Oil cooler(6) 	<ol style="list-style-type: none"> Two clamps (2) Two clamps (4) Two clamps (2) Hose (1) 	<ol style="list-style-type: none"> a. Place drain pan underneath. b. Using 3/16-inch flat-tip screwdriver, loosen. a. Place drain pan underneath. b. Using 3/16-inch flat-tip screwdriver, loosen. a. Pull off. b. Let fluid drain into drain pan. c. Get rid of drained fluid (page 2-137). d. Tag (page 2-137). Slide off. a. Pull off. b. Cap oil cooler (6) (page 2-137).
--	--	--

HYDRAULIC PUMP-TO-HYDRAULIC OIL COOLER OIL LINE (SERIAL NUMBERS 235786 THRU 235999 ONLY) - CONTINUED

LOCATION	ITEM	ACTION	REMARKS
6. Hose (3)	Two clamps (4)	Slide off.	
7. Special adapter (7)	Hose (3)	a. Pull off. b. Cap special adapter (7) (page 2-137).	

CLEANING

NOTE

For more information on how to clean parts, go to **General Maintenance Instructions (page 2-137)**.

- | | |
|---------------------|---|
| 8. All rubber parts | a. Using clean rags dampened with solution of detergent and water, wipe clean.
b. Using clean water, rinse.
c. Using clean, dry rags, wipe dry. |
|---------------------|---|

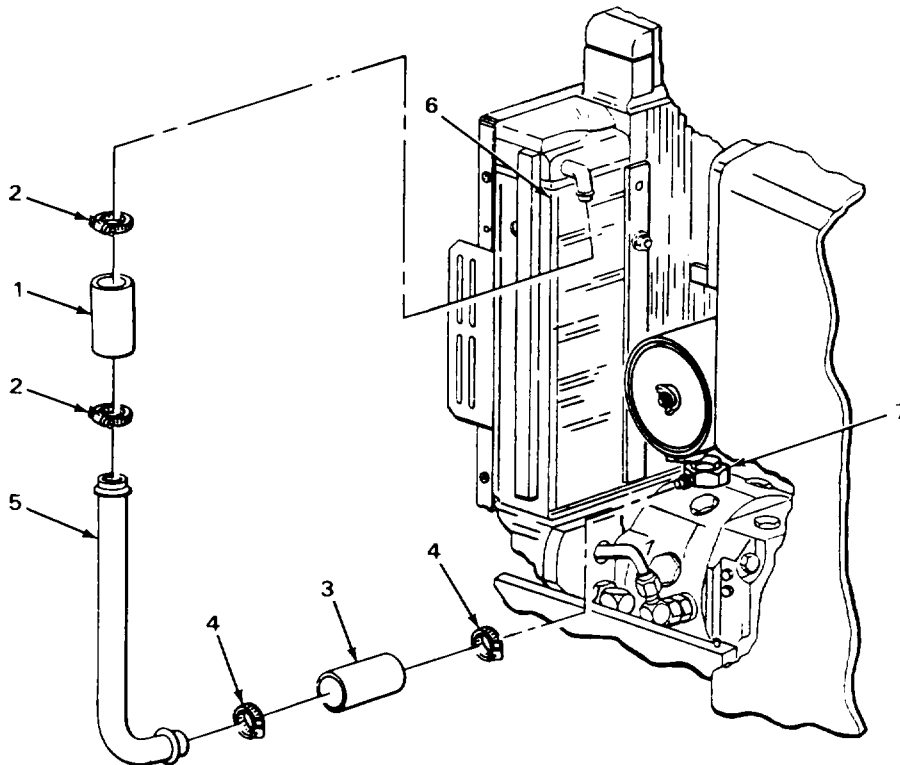

TA243377

HYDRAULIC PUMP-TO-HYDRAULIC OIL COOLER OIL LINE (SERIAL NUMBERS 235786 THRU 235999 ONLY) - CONTINUED

LOCATION	ITEM	ACTION	REMARKS
----------	------	--------	---------

CLEANING - CONTINUED

WARNING

Drycleaning solvent P-D-680 is toxic and flammable. Wear protective goggles and gloves and use only in a well ventilated area. Avoid contact with skin, eyes, and clothes and don't breathe vapors. Do not use near open flame or excessive heat. The flashpoint is 100°F to 138°F (38° to 59°C). If you become dizzy while using cleaning solvent, get fresh air immediately and get medical aid. If contact with eyes is made, wash your eyes with water and get medical aid immediately.

- | | | | |
|----|-----------------|----------------------------------|-------------------------------------|
| 9. | All metal parts | a. Clean in drycleaning solvent. | b. Using clean, dry rags, wipe dry. |
|----|-----------------|----------------------------------|-------------------------------------|

INSPECTION/REPLACEMENT

NOTE

For more information on how to inspect parts, go to General Maintenance Instructions (page 2-137).

Replace defective parts as needed.

- | | | | |
|-----|--------------------|--|--|
| 10. | All rubber parts | Look for cracks, breaks, and tears. | |
| 11. | All metal parts | Look for cracks, breaks, and abnormal bends. | |
| 12. | All threaded parts | Look for damaged threads. | |

INSTALLATION

- | | | | |
|-------------------------|----------------|--|-----------------------|
| 13. Special adapter (1) | Hose (2) | a. Uncap special adapter (1). | b. Put on. |
| 14. Hose (2) | Two clamps (3) | Place in position. | |
| 15. Oil cooler (4) | Hose (5) | a. Uncap oil cooler (4). | b. Put on. |
| 16. Hose (5) | Two clamps (6) | Place in position. | |
| 17. Two hoses (2 and 5) | Oil line (7) | a. Take off tag. | b. Place in position. |
| 18. Hose (2) | Two clamps (3) | Using 3/16-inch flat-tip screwdriver, tighten. | |

HYDRAULIC PUMP-TO-HYDRAULIC OIL COOLER OIL LINE (SERIAL NUMBERS 235786 THRU 235999 ONLY) - CONTINUED

LOCATION	ITEM	ACTION	REMARKS
19. Hose (5)	Two clamps (6)		Using 3/16-inch flat-tip screwdriver, tighten.
20. Loader backhoe	Transmission		Check fluid level and add proper amount and grade (TM 5-2420-222-10).
21.	Engine		Start and run at high idle (TM 5-2420-222-10).
22.	Hydraulic pump-to-hydraulic oil cooler line		<ol style="list-style-type: none"> Check for leaks. If leaking at any connection, tighten using 3/16-inch flat-tip screwdriver. If leaking does not stop, shut down engine (TM 5-2420-222-10) and replace defective clamp, hose or oil line as outlined in this task. If found leaking, repeat steps 20 thru 22.
23.	Engine		If still running, shut down (TM 5-2420-222-10).

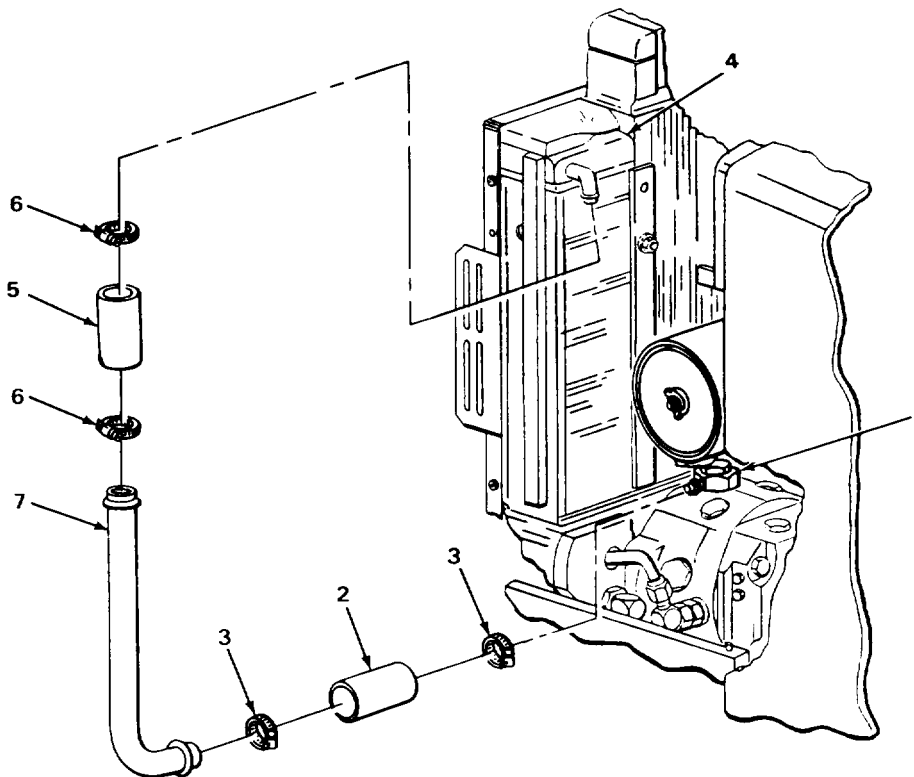

TA243378

HYDRAULIC PUMP-TO-HYDRAULIC OIL COOLER OIL LINE (SERIAL NUMBERS 235786 THRU 235999 ONLY) - CONTINUED

NOTE

FOLLOW-ON MAINTENANCE:

1. Install hood (page 2-1025).
2. Remove loader bucket support (page 2-1830).

TASK ENDS HERE

HYDRAULIC OIL FILTER RELIEF VALVE-TO-CLUTCH CONTROL VALVE ADAPTER OIL LINE

This task covers:

- | | |
|------------------------------|---|
| a. Removal (page 2-1346) | d. Inspection/Replacement (page 2-1348) |
| b. Disassembly (page 2-1347) | e. Assembly (page 2-1349) |
| c. Cleaning (page 2-1345) | f. Installation (page 2-1350) |

INITIAL SETUP:

Tools

- Pan, drain
- Screwdriver, flat-tip, 1/4-inch
- Vise, machinist's
- Wrench, open-end, 1 1/2-inch

Materials/Parts

- Detergent, GP (item 7, Appendix C)
- Rags, wiping (item 21, Appendix C)
- Solvent, drycleaning (item 28, Appendix C)
- Tags, marking (item 30, Appendix C)

Personnel Required

One

Equipment Condition

1. Hydraulic system pressure released (page 2-1191)
2. Hydraulic oil filter removed (page 2-1698)

LOCATION	ITEM	ACTION REMARKS
----------	------	-------------------

REMOVAL

- | | | |
|-----------------------|--------------------------------|--|
| 1. Clutch adapter (1) | Elbow (2) with assembled parts | <ol style="list-style-type: none"> a. Place drain pan underneath. b. Using 1 1/2-open-end wrench, unscrew and take off. c. Cap clutch adapter (1) (page 2-137). |
|-----------------------|--------------------------------|--|

HYDRAULIC OIL FILTER RELIEF VALVE-TO-CLUTCH CONTROL VALVE ADAPTER OIL LINE - CONTINUED

LOCATION	ITEM	ACTION	REMARKS
2. Hose (3)	Two clamps (4)	a. Place drain pan underneath. b. Using 1/4-inch flat-tip screwdriver, loosen.	
3. Elbow (5)	Hose (6) with assembled parts	a. Take off. b. Allow fluid to drain into drain pan. c. Get rid of drained fluid (page 2-137). d. Cap elbow (5) (page 2-137). e. Tag (page 2-137).	
DISASSEMBLY			
4. Hose (3)	Two clamps (4)	Slide off.	
5. Oil line (6)	Hose (3)	Pull off.	

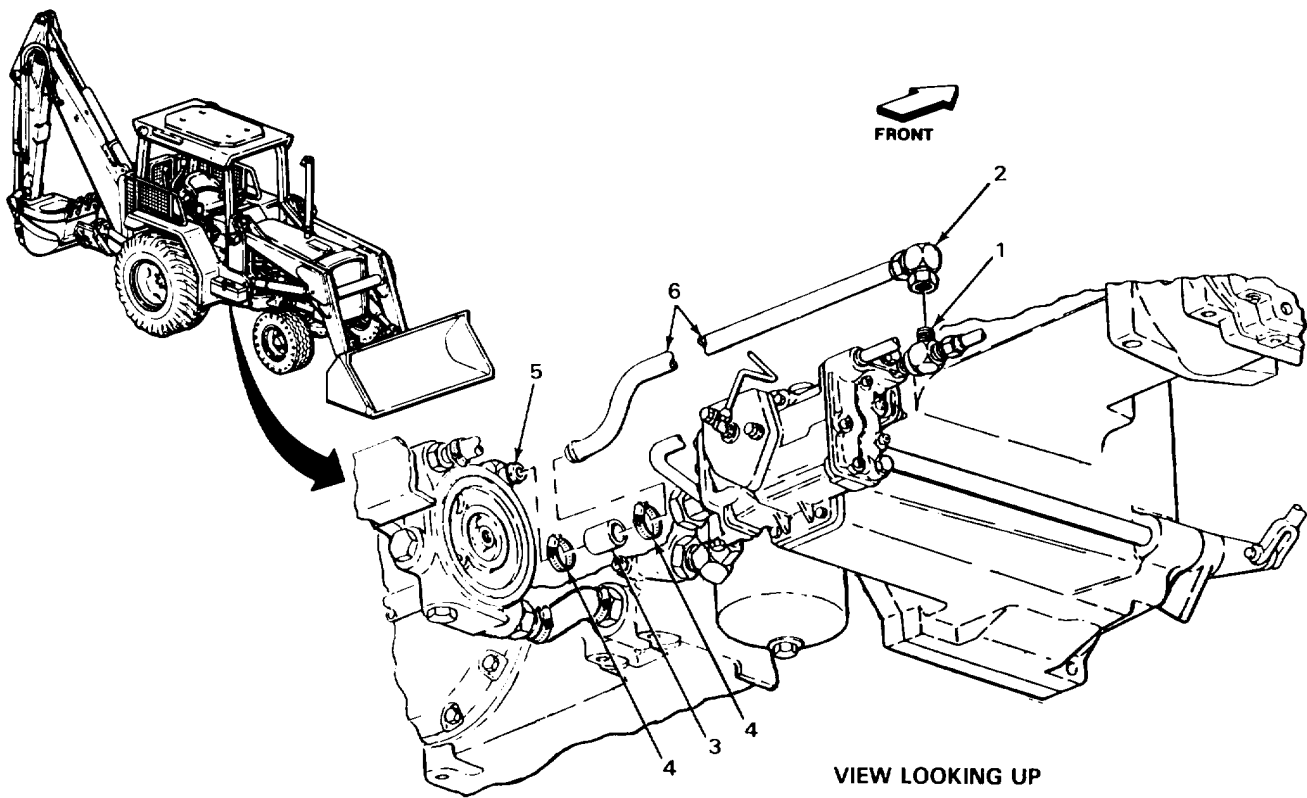

TA243379

HYDRAULIC OIL FILTER RELIEF VALVE-TO-CLUTCH CONTROL VALVE ADAPTER OIL LINE - CONTINUED

LOCATION	ITEM	ACTION	REMARKS
DISASSEMBLY - CONTINUED			
6.	Elbow (1)	Oil line (2)	<ol style="list-style-type: none"> Place elbow (1) in machinist's vise. Note relative position for proper placement during assembly. Using 1 1/2-inch open-end wrench, unscrew and take off. Take elbow (1) out of machinist's vise.

CLEANING

NOTE

For more information on how to clean parts, go to **General Maintenance Instructions (page 2-137)**.

- | | | |
|----|----------|--|
| 7. | Hose (3) | <ol style="list-style-type: none"> Using clean rags dampened with solution of detergent and water, wipe clean. Using clean water, rinse. Using clean, dry rags, wipe dry. |
|----|----------|--|

WARNING

Drycleaning solvent P-D-680 is toxic and flammable. Wear protective goggles and gloves and use only in a well ventilated area. Avoid contact with skin, eyes, and clothes and don't breathe vapors. Do not use near open flame or excessive heat. The flashpoint is 100°F to 138°F (38° to 59°C). If you become dizzy while using cleaning solvent, get fresh air immediately and get medical aid. If contact with eyes is made, wash your eyes with water and get medical aid immediately.

- | | | |
|----|-----------------|---|
| 8. | All metal parts | <ol style="list-style-type: none"> Clean in drycleaning solvent. Using clean, dry rags, wipe dry. |
|----|-----------------|---|

INSPECTION/REPLACEMENT

NOTE

For more information on how to inspect parts, go to **General Maintenance Instructions (page 2-137)**.

Replace defective parts as needed.

- | | | |
|----|----------|-------------------------------------|
| 9. | Hose (3) | Look for cracks, breaks, and tears. |
|----|----------|-------------------------------------|

HYDRAULIC OIL FILTER RELIEF VALVE-TO-CLUTCH CONTROL VALVE ADAPTER OIL LINE - CONTINUED

LOCATION	ITEM	ACTION REMARKS
10.	All metal parts	Look for cracks, breaks, and abnormal bends.
11.	All threaded parts	Look for damaged threads.
ASSEMBLY		
12. Elbow (1)	Oil line (2)	a. Place elbow (1) in machinist's vise. b. Screw in and tighten to position noted during disassembly using 1 1/2-inch open-end wrench. c. Take elbow (1) out of machinist's vise.

NOTE

New hoses are manufactured from bulk items. For more information on manufacturing new hoses, go to Appendix D.

13. Oil line (2)	Hose (3)	Put on.
14. Hose (3)	Two clamps (4)	Place in position.

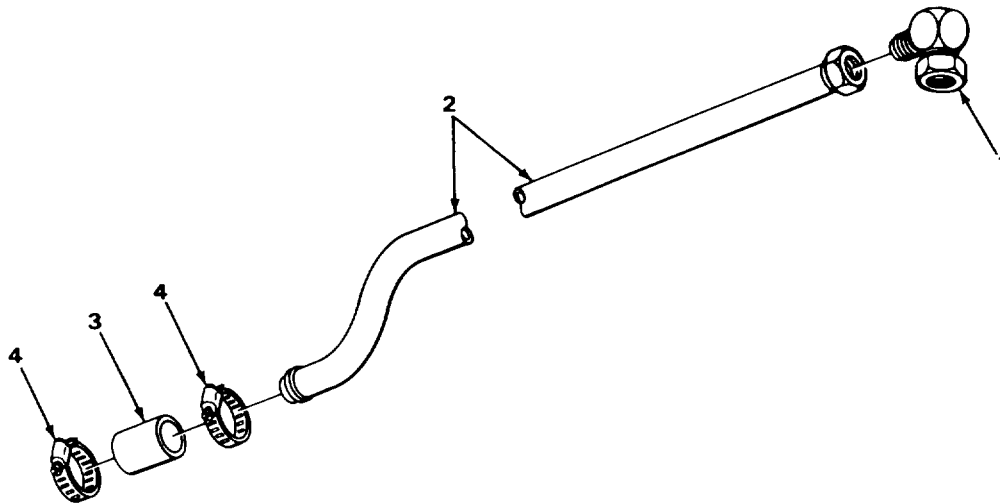

TA243380

HYDRAULIC OIL FILTER RELIEF VALVE-TO-CLUTCH CONTROL VALVE ADAPTER OIL LINE - CONTINUED

LOCATION	ITEM	ACTION REMARKS
INSTALLATION		
15. Elbow (1)	Hose (2) with two assembled parts	a. Uncap elbow (1). b. Take off tag. c. Place in position.
16. Clutch adapter (3)	Elbow (4) with assembled parts	a. Uncap clutch adapter (3). b. screw on and tighten using 1 1/2-inch open-end wrench.
17.	Two clamps (5)	Using 1/4-inch open-end wrench, tighten.
18. Loader backhoe	Hydraulic oil filter	Install (page 2-1698).
19. Transmission		Check fluid level and add proper amount and grade (TM 5-2420-222-10).
20. Engine		Start and run at high idle (TM 5-2420-222-10).
21.	Hydraulic oil filter relief valve-to-clutch control valve adapter oil line	a. Check for leaks. b. If leaking at any connection, tighten using 1 1/2-inch open-end wrench and 1/4-inch flat-tip screwdriver. c. If leaking does not stop, shut down engine (TM 5-2420-222-10) and replace leaking oil line, hose, fitting, or clamp as outlined in this task. d. If found leaking, repeat steps 19 thru 21.
22.	Engine	If still running, shut down (TM 5-2420-222-10).

HYDRAULIC OIL FILTER RELIEF VALVE-TO-CLUTCH CONTROL VALVE ADAPTER OIL LINE - CONTINUED

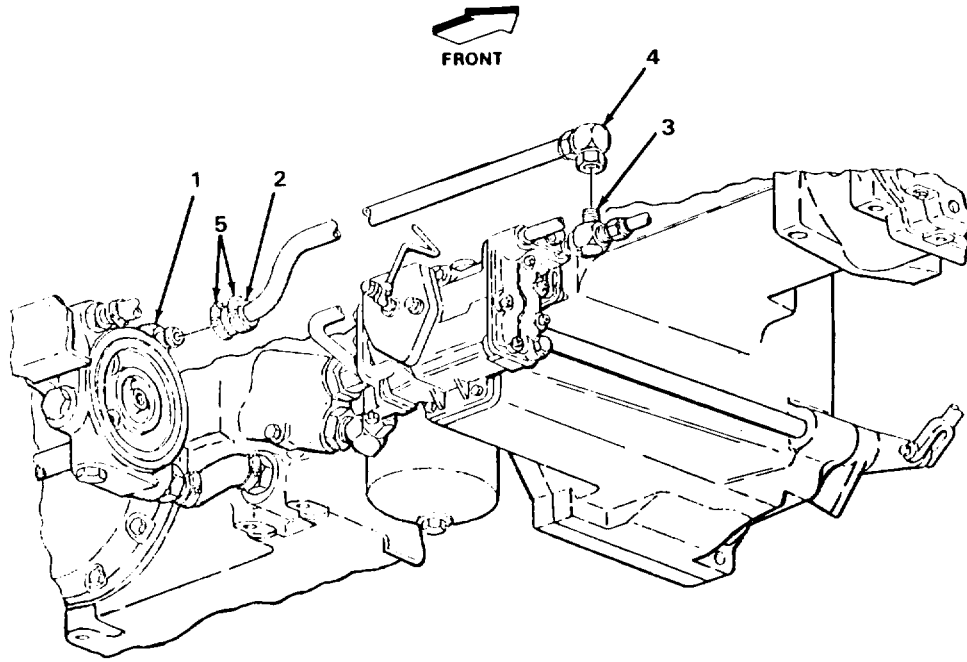

VIEW LOOKING UP

TASK ENDS HERE

TA243381

2-1351

CLUTCH CONTROL VALVE-TO-HYDRAULIC PUMP INLET OIL LINE

This task covers:

- | | |
|------------------------------|---|
| a. Removal (page 2-1352) | d. Inspection/Replacement (page 2-1356) |
| b. Disassembly (page 2-1354) | e. Assembly (page 2-1357) |
| c. Cleaning (page 2-1356) | f. Installation (page 2-1357) |

INITIAL SETUP:

Tools

- Extension, 1/2-inch drive, 5-inch
- Handle, ratchet, 1/2-inch drive
- Pan, drain
- Screwdriver, flat-tip, 1/4-inch
- Socket, 1/2-inch drive, 7/16-inch
- Socket, 1/2-inch drive, 1/2-inch
- Socket, 1/2-inch drive, 9/16-inch
- Vise, machinist's
- Wrench, box, 9/16-inch
- Wrench, open-end, 7/16-inch
- Wrench, open-end, 1/2-inch
- Wrench, open-end, 1 1/2-inch
- Wrench, torque, 1/2-inch drive, 0 to 150 foot-pound capacity

Materials/Parts

- Detergent, GP (item 7, Appendix C)
- Lockwasher, bracket screw, (two required)
- Lockwasher, clamp screw (two required)
- Packing, clutch control valve adapter
- Rags, wiping (item 21, Appendix C)
- Solvent, drycleaning (item 28, Appendix C)
- Tags, marking (item 30, Appendix C)

Personnel Required

One

Equipment Condition

1. Radiator removed (page 2-371)
2. Hydraulic system pressure released (page 2-1191)

LOCATION	ITEM	ACTION	REMARKS
----------	------	--------	---------

REMOVAL

WARNING

Do not attempt to disconnect hydraulic lines and fittings while engine is running or before hydraulic system pressure has been released. When engine is running, hydraulic system is under pressure. Hydraulic system pressure should be 0 psi (0 kPa) before lines are disconnected. A line or fitting disconnected under pressure will blow off with a lot of force and could cause serious injury to personnel.

Be careful when draining hot fluids. Wear gloves to protect your hands from hot parts and fluids or severe burns could result.

- | | | |
|-----------------------|-----------------------------------|---|
| 1. Clutch adapter (1) | Elbow (2)
with assembled parts | <ol style="list-style-type: none"> a. Place drain pan underneath. b. Using 1 1/2-inch open-end wrench, unscrew and take off. c. Plug (page 2-137). |
|-----------------------|-----------------------------------|---|

CLUTCH CONTROL VALVE-TO-HYDRAULIC PUMP INLET OIL LINE - CONTINUED

LOCATION	ITEM	ACTION	REMARKS
2. Clutch control valve (3) and special washer (4)	Screw (5) and take out.	Using 9/16-inch box wrench, unscrew	
3. Clutch adapter (1) and oil line (6)	Special washer (4)	Take off.	
4. Two hose clamps (7)	Two screws (8), washers (9), and nuts (10)	Using 7/16-inch, 1/2-inch drive socket, ratchet handle, and 7/16-inch open-end wrench, unscrew and take apart.	
5. Two clamps (11 and 12) and five oil lines (13 thru 17)	Two hose clamps (7)	Take off.	

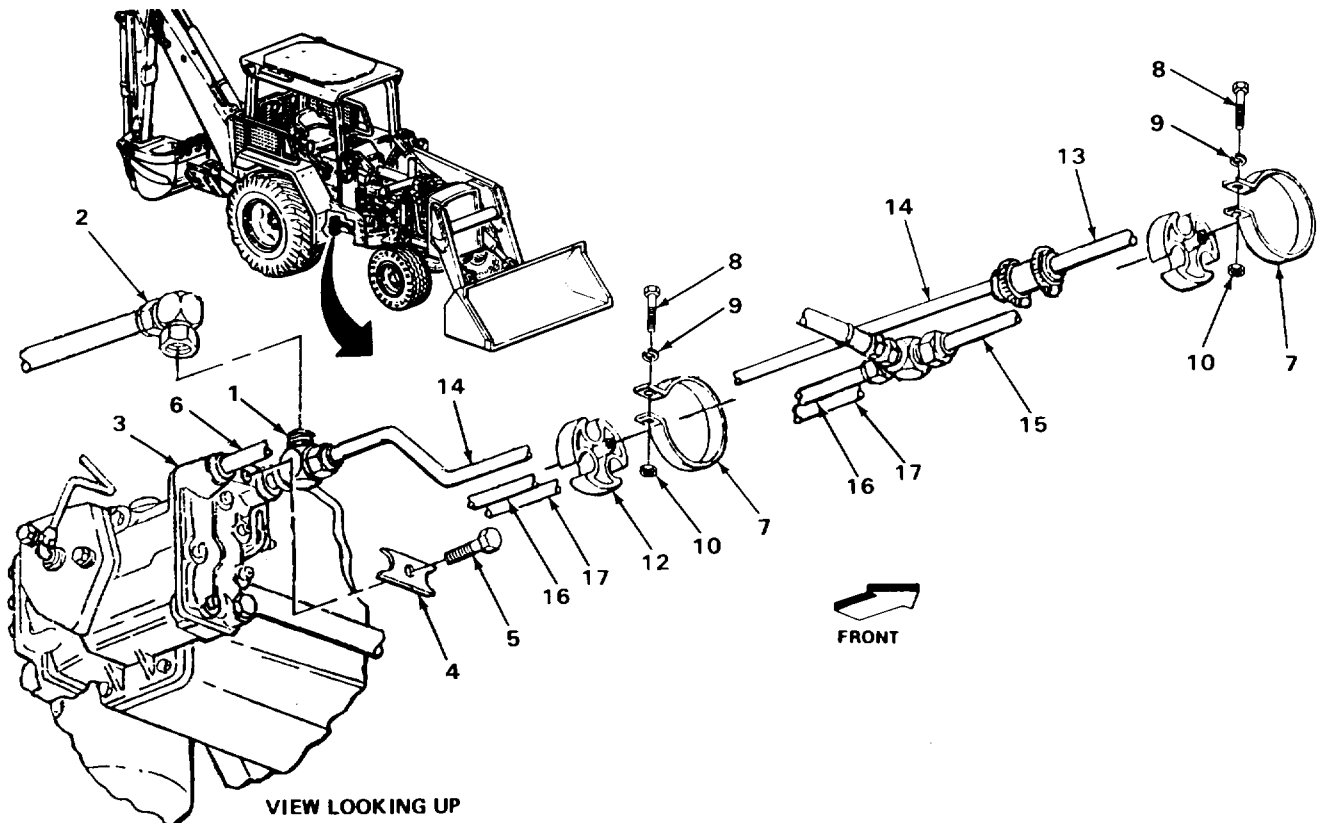

TA243382

CLUTCH CONTROL VALVE-TO-HYDRAULIC PUMP INLET OIL LINE - CONTINUED

LOCATION	ITEM	ACTION REMARKS
REMOVAL - CONTINUED		
6. Hose (1)	Clamp (2)	a. Place drain pan underneath. b. Using 1/4-inch flat-tip screwdriver, loosen.
7. Hose (1), clamp (3) and elbow (4)	Oil line (5)	a. Place drain pan underneath. b. Using 1 1/2-inch open-end wrench, screw off of elbow (14). c. Take out. d. Cap elbow(14). e. Tag (page 2-137).
8. Clutch control valve (6) and clamp (7)	Oil line (8) with assembled parts and packing (9)	a. Place drain pan underneath. b. Take out. c. Get rid of packing (16). d. Get rid of drained oil (page 2-137). e. Plug valve(15). f. Tag oil line (8) page 2-137).
NOTE		
Oil line mounting brackets and clamps support five oil lines. Do not remove brackets or clamps unless inspection shows need for replacement.		
9. Two clamps (3 and 7) and two brackets (10)	Two screws (11), lockwashers (12), and nuts (13)	a. Using 1/2-inch, 1/2-inch drive socket, ratchet handle, and 1/2-inch open-end wrench, unscrew and take apart. b. Get rid of lockwashers (19).
10. Two brackets (10) and three oil lines (14 thru 16)	Two clamps (3 and 7)	Take off.
11. Two brackets (10), oil pan (17), and engine block (18)	Two screws (19), and lockwashers (20)	a. Using 9/16-inch, 1/2-inch drive socket, 5-inch extension, and ratchet handle, unscrew and take out. b. Get rid of lockwashers (24).
12. Oil pan (17)	Two brackets (10)	Take off.
DISASSEMBLY		
13. Hose (1)	Clamps (2 and 21)	Using 1/4-inch flat-tip screwdriver, loosen.

CLUTCH CONTROL VALVE-TO-HYDRAULIC PUMP INLET OIL LINE - CONTINUED

LOCATION	ITEM	ACTION	REMARKS
----------	------	--------	---------

14.	Two clamps (2 and 21)	Slide off.	
-----	--------------------------	------------	--

15. Oil line (8)	Hose (1)	Pull off.	
------------------	----------	-----------	--

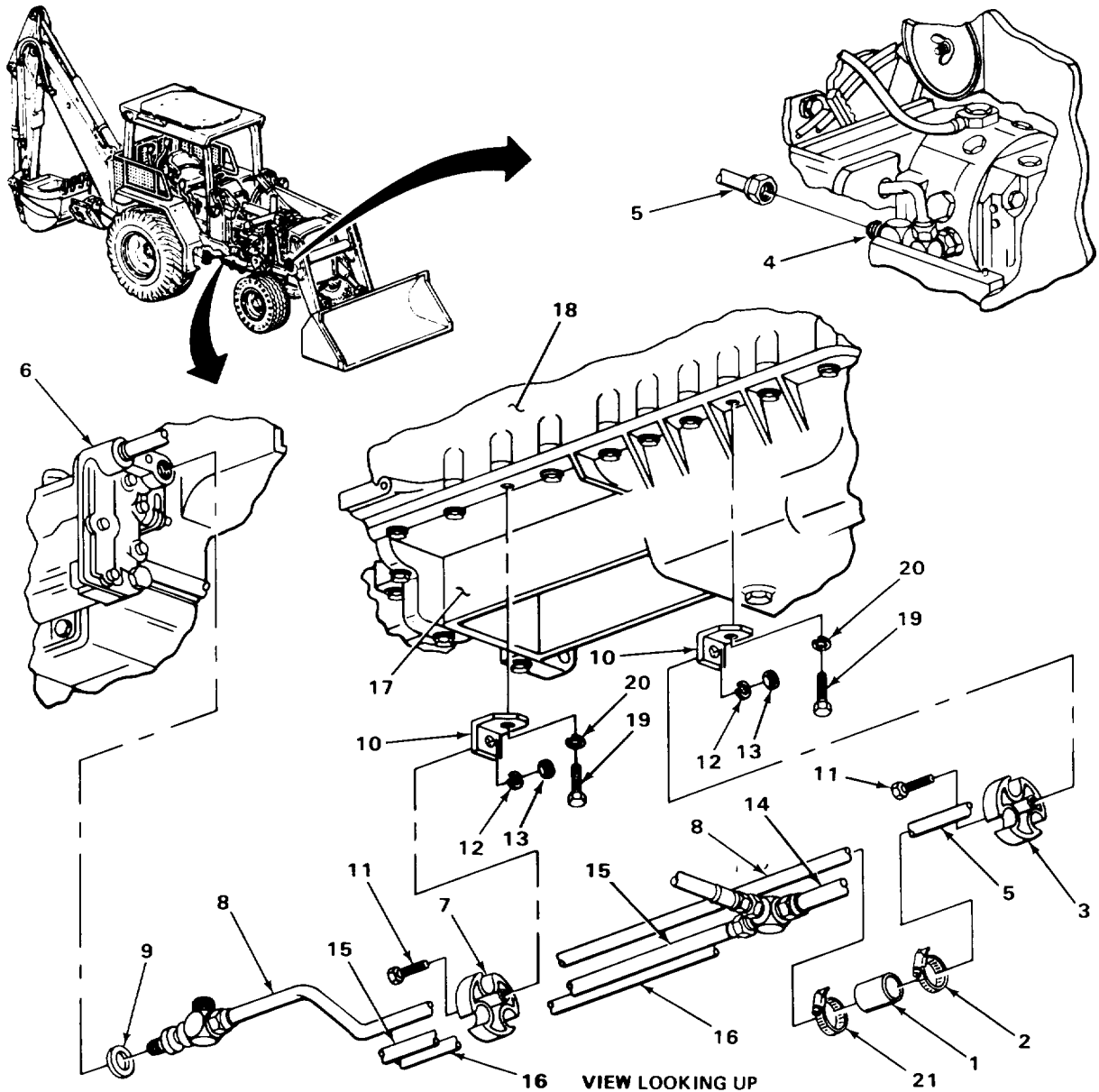

TA243383

CLUTCH CONTROL VALVE-TO-HYDRAULIC PUMP INLET OIL LINE - CONTINUED

LOCATION	ITEM	ACTION	REMARKS
DISASSEMBLY - CONTINUED			
16. Clutch adapter (1)	Oil line (2)	a. Place clutch adapter (1) in machinist's vise. b. Note relative position for proper placement during assembly. c. Using 1 1/2-inch open-end wrench, unscrew and take off. d. Take clutch adapter (1) out of machinist's vise.	

CLEANING

NOTE

For more information on how to clean parts, go to **General Maintenance Instructions (page 2-137)**.

17.	All rubber parts	a. Using clean rags dampened with solution of detergent and water, wipe clean. b. Rinse with clean water. c. Using clean, dry rags, wipe dry.	
-----	------------------	---	--

WARNING

Drycleaning solvent P-D-680 is toxic and flammable. Wear protective goggles and gloves and use only in a well ventilated area. Avoid contact with skin, eyes, and clothes and don't breathe vapors. Do not use near open flame or excessive heat. The flashpoint is 100°F to 138°F (38° to 59°C). If you become dizzy while using cleaning solvent, get fresh air immediately and get medical aid. If contact with eyes is made, wash your eyes with water and get medical aid immediately.

18.	All metal parts	a. Clean in drycleaning solvent. b. Using clean, dry rags, wipe dry.	
-----	-----------------	---	--

INSPECTION/REPLACEMENT

NOTE

For more information on how to inspect parts, go to **General Maintenance Instructions (page 2-137)**.

Replace defective parts as needed.

19.	All rubber parts	Look for cracks, breaks, and tears.	
-----	------------------	-------------------------------------	--

CLUTCH CONTROL VALVE-TO-HYDRAULIC PUMP INLET OIL LINE - CONTINUED

LOCATION	ITEM	ACTION	REMARKS
20.	All metal parts		Look for cracks, breaks, and abnormal bends.
21.	All threaded parts		Look for damaged threads.
ASSEMBLY			
22. Clutch adapter (1)	Oil line (2)	a. Place clutch adapter (1) in machinist's vise. b. Screw on to same relative position noted during disassembly using 1 1/2-inch open-end wrench. c. Take clutch adapter (1) out of machinist's vise.	
23. Oil line (2)	Hose (3)		Place in position.
24. Hose (3)	Two clamps (4 and 5)		Place in position.
25.	Clamp (4)		Using 1/4-inch flat-tip screwdriver, tighten.

INSTALLATION

NOTE

If oil line mounting brackets and clamps were not taken off during removal, skip steps 26 thru 29.

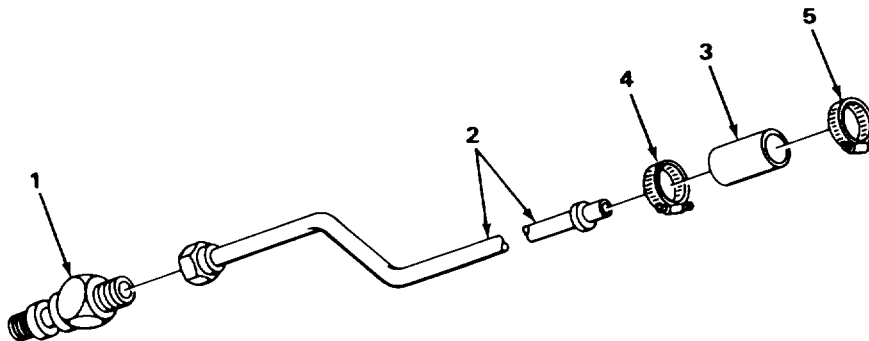

TA243384

CLUTCH CONTROL VALVE-TO-HYDRAULIC PUMP INLET OIL LINE - CONTINUED

LOCATION	ITEM	ACTION REMARKS
INSTALLATION - CONTINUED		
26. Oil pan (1)	Two brackets (2)	Place in position.
27. Two brackets (2), oil pan (1), and engine block (3)	Two screws (4) and new lockwashers (5)	a. Screw in and tighten until snug using 9/16-inch, 1/2-inch drive socket, 5-inch extension, and ratchet handle. b. Using 9/16-inch, 1/2-inch drive socket, 5-inch extension, and 0 to 150 foot-pound torque wrench, tighten to 50 foot-pounds (68 N m) torque.
28. Two brackets (2) and three oil lines (6 thru 8)	Two clamps (9 and 10)	Place in position.
29. Two clamps (9 and 10) and two brackets (2)	Two screws (11), new lockwashers (12), and nuts (13)	Screw together and tighten using 1/2-inch, 1/2-inch drive socket, ratchet handle, and 1/2-inch open-end wrench.
30. Clutch control valve (14) and clamp (9)	Oil line (15) with assembled parts and new packing (16)	a. Unplug valve (14). b. Place in position. c. Take off tag.
31. Hose (17), clamp (10), and elbow (18)	Oil line (19)	a. Take off tag. b. Uncap elbow (18). c. Place in position. d. Screw onto elbow (18) using 1 1/2-inch open-end wrench.
32. Hose (17)	Clamp (20)	Using 1/4-inch flat-tip screwdriver, tighten.
33. Two clamps (9 and 10) and five oil lines (6 thru 8, 15, and 19)	Two hose clamps (21)	Place in position.
34. Two hose clamps (21)	Two screws (22), washers (23), and nuts (24)	Screw together and tighten using 7/16-inch, 1/2-inch drive socket, ratchet handle, and 7/16-inch open-end wrench.
35. Clutch adapter (25) and oil line (6)	Special washer (26)	Place in position.

CLUTCH CONTROL VALVE-TO-HYDRAULIC PUMP INLET OIL LINE - CONTINUED

LOCATION	ITEM	ACTION	REMARKS
36. Clutch control valve (14) and special washer (26)	Screw (27)	Screw in and tighten using 9/16-inch box wrench.	
37. Clutch adapter (25)	Elbow (28) with assembled parts	a. Unplug. b. Screw on and tighten using 1 1/2-inch open-end wrench.	

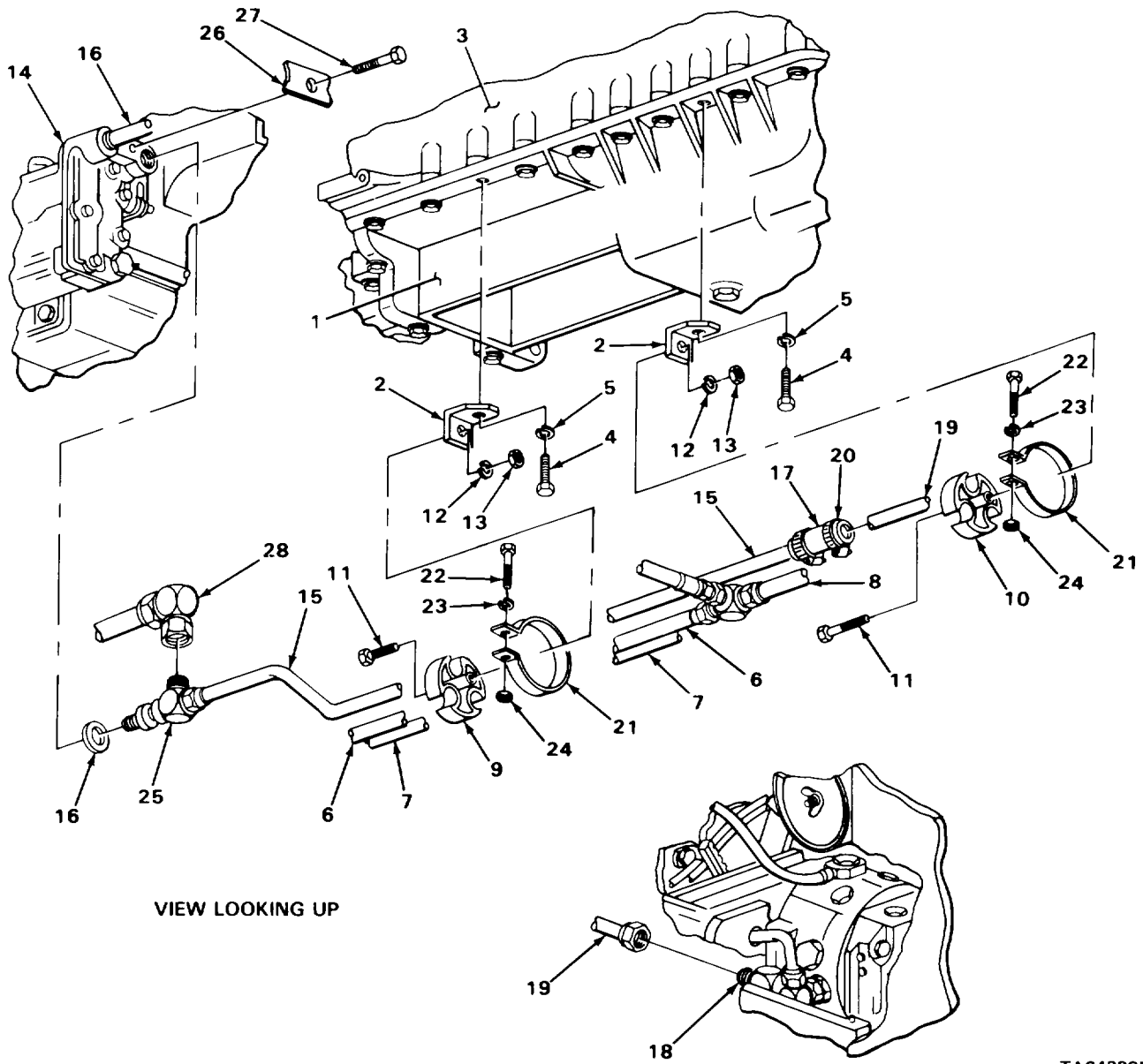

TA243385

CLUTCH CONTROL VALVE-TO-HYDRAULIC PUMP INLET OIL LINE - CONTINUED

LOCATION	ITEM	ACTION REMARKS
INSTALLATION - CONTINUED		
38. Loader backhoe	Radiator	Install (page 2-371). Do not install right side grille at this time.
39.	Transmission	Check fluid level and add proper amount and grade (TM 5-2420-222-10).
40. Loader backhoe	Engine	Start and run at high idle (TM 5-2420-222-10).
41.	Clutch control valve-to-hydraulic pump inlet oil line	<ol style="list-style-type: none"> a. Check for leaks. b. If leaking at any connection, tighten using 9/16-inch box wrench, 1 1/2-inch open-end wrench, and 1/4-inch flat-tip screwdriver. c. If leaking does not stop, shut down engine (TM 5-2420-222-10) and replace leaking connection packing, hose, oil line, or fitting as outlined in this task. d. If found leaking, repeat steps 39 thru 41.
42.	Engine	If still running, shut down (TM 5-2420-222-10).

NOTE

FOLLOW-ON MAINTENANCE: Install right side grille (TM 5-2420-222-10).

TASK ENDS HERE

HYDRAULIC OIL COOLER-TO-CLUTCH CONTROL VALVE OIL LINE

This task covers:

- | | |
|------------------------------|---|
| a. Removal (page 2-1362) | d. Inspection/Replacement (page 2-1365) |
| b. Disassembly (page 2-1364) | e. Assembly (page 2-1365) |
| c. Cleaning (page 2-1364) | f. Installation (page 2-1366) |
-

INITIAL SETUP

Tools

Extension, 1/2-inch drive, 5-inch
 Handle, ratchet, 1/2-inch drive
 Pan, drain
 Screwdriver, flat-tip, 1/4-inch
 Socket, 1/2-inch drive, 7/16-inch
 Socket, 1/2-inch drive, 1/2-inch
 Socket, 1/2-inch drive, 9/16-inch
 Wrench, box, 9/16-inch
 Wrench, open-end, 7/16-inch
 Wrench, open-end, 1/2-inch
 Wrench, torque, 1/2-inch drive,
 0 to 150 foot-pound capacity

Materials/Parts

Detergent, GP (item 7, Appendix C)
 Lockwasher, bracket screw, (two required)
 Lockwasher, clamp screw (two required)
 Packing, clutch control valve-to-oil line
 Rags, wiping (item 21, Appendix C)
 Solvent, drycleaning (item 28, Appendix C)
 Tags, marking (item 30, Appendix C)

Personnel Required

One

Equipment Condition

1. Hydraulic system pressure released
(page 2-1191)
2. Right side grille removed
(TM 5-2420-222-10)

2-1361

HYDRAULIC OIL COOLER-TO-CLUTCH CONTROL VALVE OIL LINE - CONTINUED

LOCATION	ITEM	ACTION	REMARKS
REMOVAL			
<u>WARNING</u>			
<p>Do not attempt to disconnect hydraulic lines and fittings while engine is running or before hydraulic system pressure has been released. When engine is running, hydraulic system is under pressure. Hydraulic system pressure should be 0 psi (0 kPa) before lines are disconnected. A line or fitting disconnected under pressure will blow off with a lot of force and could cause serious injury to personnel.</p> <p>Be careful when draining hot fluids. Wear gloves to protect your hands from hot parts and fluids or severe burns could result.</p>			
1. Hose (1)	Hose clamp (2)	a. Place drain pan underneath. b. Using 1/4-inch flat-tip screwdriver, loosen.	
2. Clutch control valve (3) and	Screw (5)	a. Place drain pan underneath. b. Using 9/16-inch box wrench, unscrew special washer (4) and take out.	
3. Clutch adapter (6) and oil line (7)	Special washer (4)	Take off.	
4. Two hose clamps (8)	Two screws (9), washers (10), and nuts (11)	Using 7/16-inch, 1/2-inch drive socket, ratchet handle, and 7/16-inch open-end wrench, unscrew and take apart.	
5. Two clamps (12) and five oil lines (7,13,14,15, and 16)	Two hose clamps (8)	Take off.	
6. Clutch control valve (3), two clamps (12), and oil cooler (17)	Oil line (7) with assembled hose (1), two hose clamps (2 and 18), and packing (19)	a. Take off. b. Allow fluid to drain into drain pan. c. Tag (page 2-137). d. Get rid of drained fluid (page 2-137). e. Plug valve (3) and oil cooler (17) (page 2-137). f. Get rid of packing (19).	

HYDRAULIC OIL COOLER-TO-CLUTCH CONTROL VALVE OIL LINE - CONTINUED

LOCATION	ITEM	ACTION	REMARKS
----------	------	--------	---------

NOTE

Oil line mounting brackets and clamps support five oil lines. Do not remove brackets or clamps unless inspection shows need for replacement.

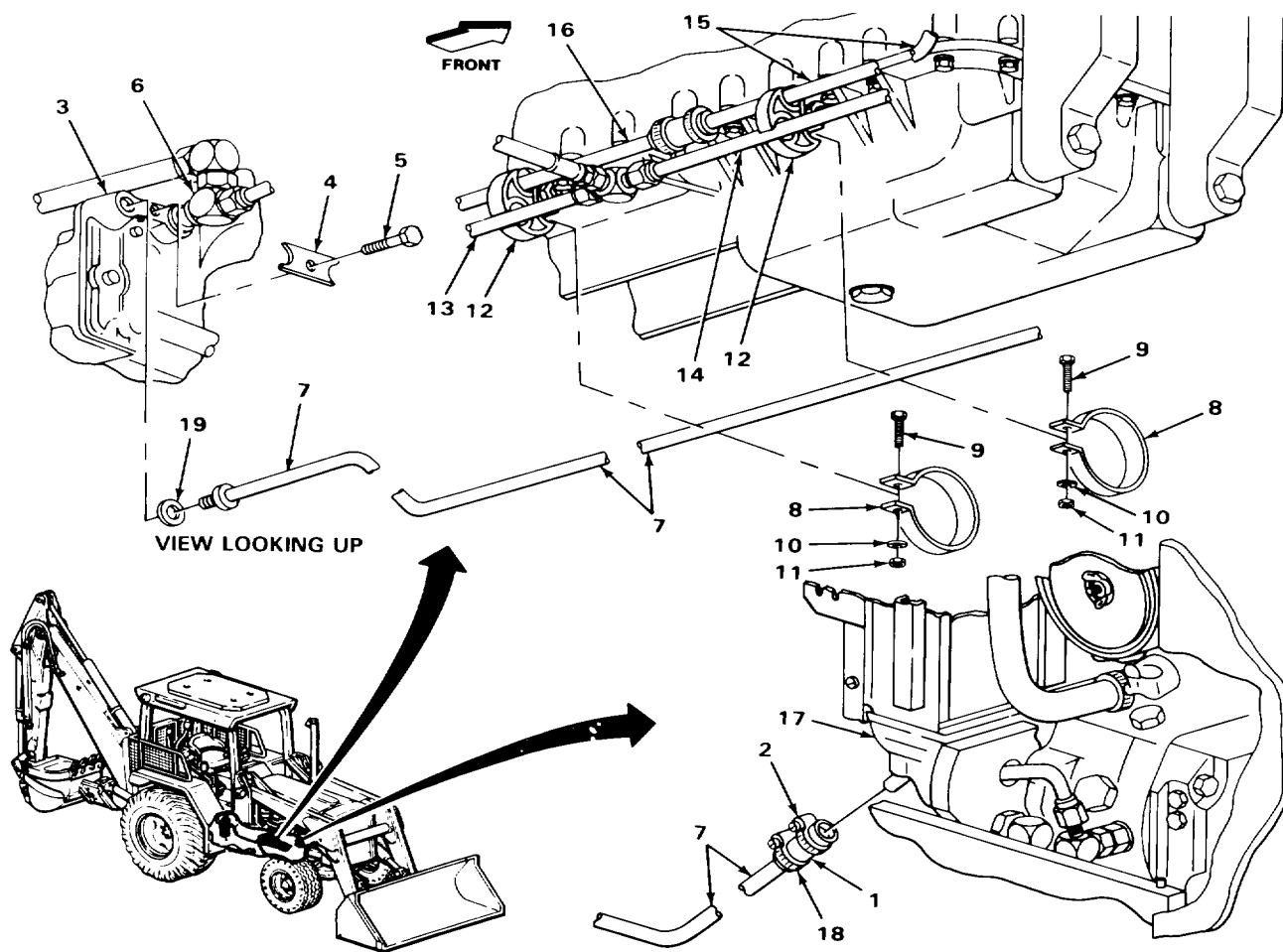

HYDRAULIC OIL COOLER-TO-CLUTCH CONTROL VALVE OIL LINE - CONTINUED

LOCATION	ITEM	ACTION	REMARKS
REMOVAL - CONTINUED			
7.	Two clamps (1) and two brackets (2)	Two screws (3), lockwashers (4), and nuts (5)	a. Using 1/2-inch, 1/2-inch drive socket, ratchet handle, and 1/2-inch open-end wrench, unscrew and take apart. b. Get rid of lockwashers (4).
8.	Two brackets (2) and four oil lines (6 thru 9)	Two clamps (1)	Take off.
9.	Two brackets (2), oil pan (10), and engine block (11)	Two screws (12), and lockwashers (13)	a. Using 9/16-inch, 1/2-inch drive socket, 5-inch extension, and ratchet handle, unscrew and take out. b. Get rid of lockwashers (13).
10	Oil pan (10)	Two brackets (2)	Take off.

DISASSEMBLY

11	Hose (14)	Clamp (15)	Using 1/4-inch flat-tip screwdriver, loosen.
12		Two clamps (15 and 16)	Slide off.
13	Oil line (17)	Hose (14)	Pull off.

CLEANING**NOTE**

For more information on how to clean parts, go to **General Maintenance Instructions (page 2-137)**.

14	All rubber parts	a. Using clean rags dampened with solution of detergent and water, wipe clean. b. Rinse with clean water. c. Using clean, dry rags, wipe dry.
----	------------------	---

WARNING

Drycleaning solvent P-D-680 is toxic and flammable. Wear protective goggles and gloves and use only in a well ventilated area. Avoid contact with skin, eyes, and clothes and don't breathe vapors. Do not use near open flame or excessive heat. The flashpoint is 100°F to 138°F (38 to 59°C). If you become dizzy while using cleaning solvent, get fresh air immediately and get medical aid. If contact with eyes is made, wash your eyes with water and get medical aid immediately.

HYDRAULIC OIL COOLER-TO-CLUTCH CONTROL VALVE OIL LINE - CONTINUED

LOCATION	ITEM	ACTION	REMARKS
15	All metal parts	a. Clean in drycleaning solvent. b. Using clean, dry rags, wipe dry.	

INSPECTION/REPLACEMENT

NOTE

For more information on how to inspect parts, go to **General Maintenance Instructions (page 2-137)**.

Replace defective parts as needed.

16	All rubber parts	Look for cracks, breaks, and tears.
17	All metal parts	Look for cracks, breaks, and abnormal bends.
18	All threaded parts	Look for damaged threads.

ASSEMBLY

19	Oil line (17)	Hose (14)	Place in position.
20	Hose (14)	Two clamps (15 and 16)	Place in position.

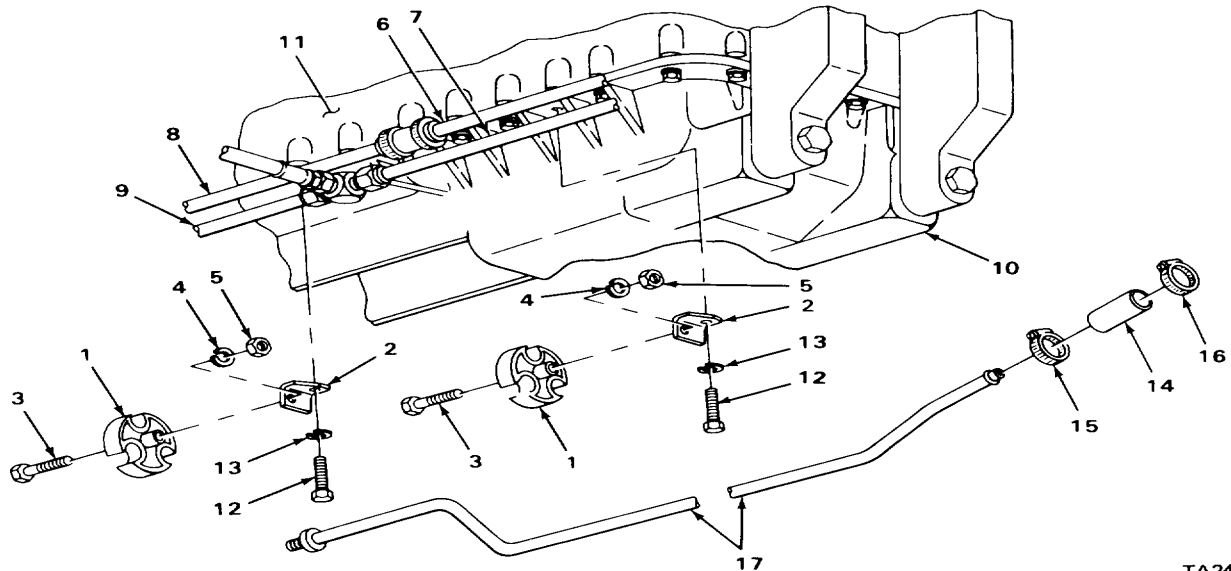

TA243387

HYDRAULIC OIL COOLER-TO-CLUTCH CONTROL VALVE OIL LINE - CONTINUED

LOCATION	ITEM	ACTION	REMARKS
INSTALLATION			
NOTE			
If oil line mounting brackets and clamps were not taken off during removal, skip steps 21 thru 24.			
21	Oil pan (1)	Two brackets (2)	Place in position.
22	Two brackets (2), oil pan (1), and engine block (3)	Two screws (4) and new lockwashers (5)	a. Screw in and tighten until snug using 9/16-inch, 1/2-inch drive socket, 5-inch extension, and ratchet handle. b. Using 9/16-inch, 1/2-inch drive socket, 5-inch extension, and 0 to 150 foot-pound capacity torque wrench, tighten to 50 foot-pounds (68 N•m) torque.
23	Two brackets (2) and four oil lines (6 thru 9)	Two clamps (10)	Place in position.
24	Two clamps (10) and two brackets (2)	Two screws (11), new lockwashers (12), and nuts (13)	Screw together and tighten using 1/2-inch, 1/2-inch drive socket, ratchet handle, and 1/2-inch open-end wrench.
25	Clutch control valve (14) two clamps (10), and oil cooler (15)	Oil line (16) with assembled hose (17), and two hose clamps (18), and new packing (19)	a. Unplug valve (14) and oil cooler (15). b. Take off tag. c. Place in position.
26	Two clamps (10) and five oil lines (6, 7, 8, 9, and 16)	Two hose clamps (20)	Place in position.
27	Two hose clamps (20)	Two screws (21), washers (22), and nuts (23)	Screw together and tighten using 7/16-inch, 1/2-inch drive socket, ratchet handle, and 7/16-inch open-end wrench.
28	Clutch adapter (24) and oil line (16)	Special washer (25)	Place in position.

HYDRAULIC OIL COOLER-TO-CLUTCH CONTROL VALVE OIL LINE - CONTINUED

LOCATION	ITEM	ACTION	REMARKS
29 Clutch control valve (14) and special washer (25)	Screw (26)	Screw in and tighten using 9/16-inch box wrench.	
30 Hose (17)	Two clamps (18)	Using 1/4-inch flat-tip screwdriver, tighten.	

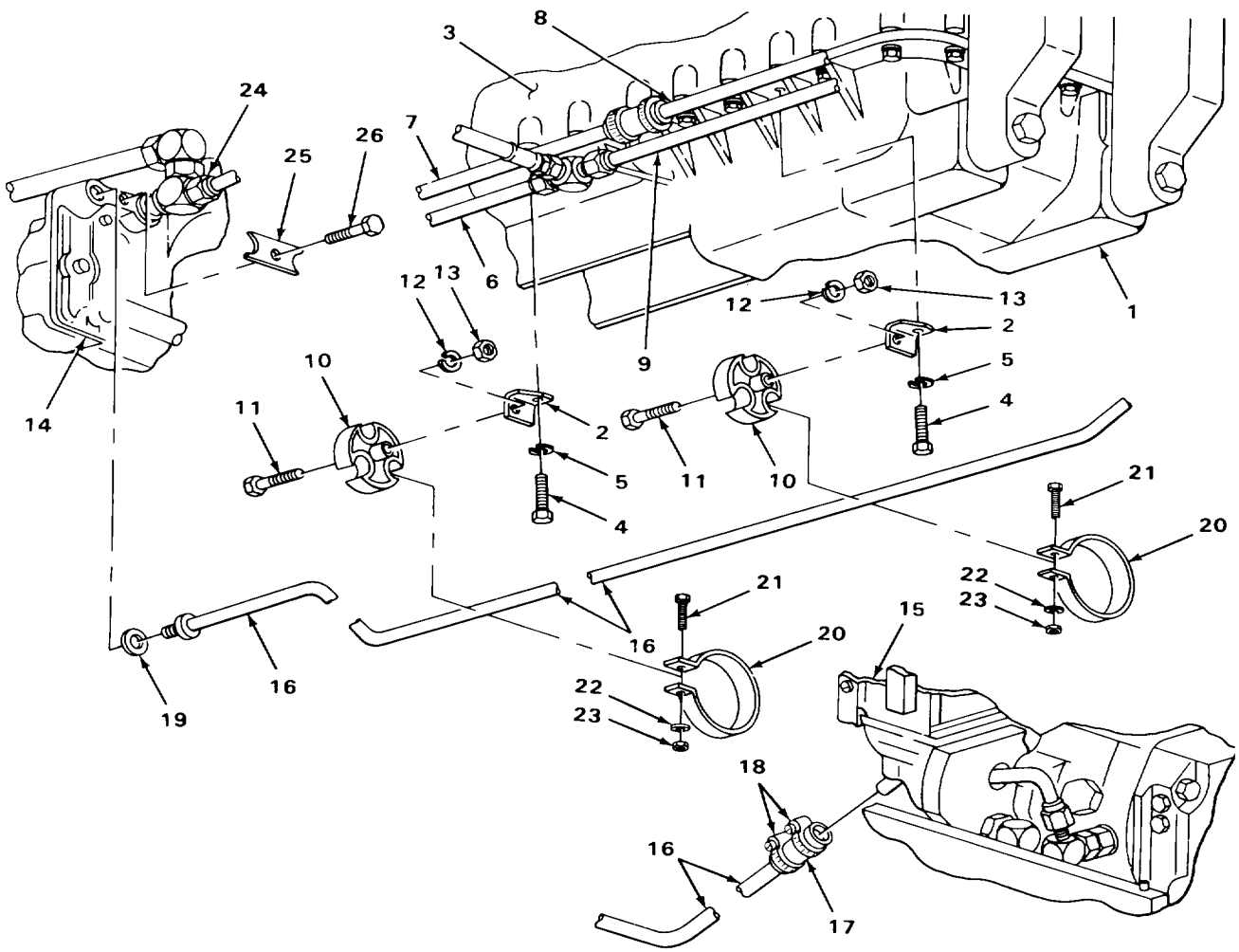

HYDRAULIC OIL COOLER-TO-CLUTCH CONTROL VALVE OIL LINE - CONTINUED

LOCATION	ITEM	ACTION	REMARKS
31	Loader backhoe	Transmission	Check fluid level and add proper amount and grade (TM 5-2420-222-10).
32		Engine	Start and run at high idle (TM 5-2420-222-10).
33	Hydraulic oil cooler-to-clutch control valve oil line		<ul style="list-style-type: none"> a. Check for leaks. b. If leaking at any connection, tighten using 9/16-inch box wrench or 1/4-inch flat-tip screwdriver. c. If leaking does not stop, shut down engine (TM 5-2420-222-10) and replace leaking connection packing, hose, hose clamp, or oil line as outlined in this task. d. If found leaking, repeat steps 31 thru 33.
34		Engine	If still running, shut down (TM 5-2420-222-10).

NOTE

FOLLOW-ON MAINTENANCE: Install right side grille (TM 5-2420-222-10).

TASK ENDS HERE

HYDRAULIC PUMP-TO-SPEED GEAR ASSEMBLY (REVERSER) SEAL DRAIN LINE

This task covers:

- | | | | |
|----|------------------------|----|--------------------------------------|
| a. | Removal (page 2-1370) | c. | Inspection/Replacement (page 2-1372) |
| b. | Cleaning (page 2-1371) | d. | Installation (page 2-1372) |
-

INITIAL SETUP:**Tools**

Extension, 3/8-inch drive, 5-inch
 Handle, ratchet, 3/8-inch drive
 Knife, pocket
 Pan, drain
 Pliers, diagonal-cutting
 Pliers, slip-joint
 Socket, 3/8-inch drive, 9/16-inch
 Wrench, open-end, 7/16-inch
 (two required)
 Wrench, open-end, 1/2-inch

Materials/Parts

Band, electrical tie down
 (seven required)
 Detergent, GP (item 7, Appendix C)
 Lockwasher, clamp screw
 Packing, elbow-to-hydraulic pump

Materials/Parts

Rags, wiping (item 21, Appendix C)
 Solvent, drycleaning (item 28, Appendix C)
 Tags, marking (item 30, Appendix C)

Personnel Required

One

Equipment Condition

1. Right side grille removed
 (TM 5-2420-222-10)
2. Right platform removed (page 2-1079)

HYDRAULIC PUMP-TO-SPEED GEAR ASSEMBLY (REVERSER) SEAL DRAIN LINE - CONTINUED

LOCATION	ITEM	ACTION	REMARKS
REMOVAL			
WARNING			
Be careful when draining hot fluids. Wear gloves to protect your hands from hot parts and fluids or severe burns could result.			
1	Elbow (1)	Oil line (2)	<ul style="list-style-type: none"> a Place drain pan underneath. b Using 7/16-inch open-end wrench, unscrew and take off. c Tag (page 2-137).
2	Elbow (1) and hydraulic pump (3)	Nut (4)	Using 7/16 and 1/2-inch open-end wrenches, loosen.
3	Hydraulic pump (3)	Elbow (1) with assembled parts	<ul style="list-style-type: none"> a Note relative position for proper placement during installation. b Using 7/16-inch open-end wrench, unscrew and take out. c Plug pump (3) (page 2-137).
4	Elbow (1)	Packing (5)	<ul style="list-style-type: none"> a Using pocket knife, take off. b Get rid of.
5	Front support (6) and clamp (7)	Screw (8) and lockwasher (9)	<ul style="list-style-type: none"> a Using 9/16-inch, 3/8-inch drive socket, 5-inch extension, and ratchet handle, unscrew and take out. b Get rid of lockwasher (9).
6	Front support (6) and oil line (2)	Clamp (7)	Take off.
7	Oil line (2)	Seven electrical tie down bands (10)	<ul style="list-style-type: none"> a Note locations for proper placement installation. b Using diagonal-cutting pliers, cut off. c Get rid of.
8	Straight adapter (11)	Oil line (2)	<ul style="list-style-type: none"> a Place drain pan underneath. b Using two 7/16-inch open-end wrenches, unscrew and take off. c Allow fluid to drain into drain pan. d Tag (page 2-137). e Get rid of drained fluid (page 2-137).

HYDRAULIC PUMP-TO-SPEED GEAR ASSEMBLY (REVERSER) SEAL DRAIN LINE - CONTINUED

LOCATION	ITEM	ACTION	REMARKS
9 Speed gear assembly top cover (12)	Straight adapter (11)	a Using 7/16-inch open-end wrench, unscrew and take out. b Plug cover (12) (page 2-137).	

CLEANING

NOTE

For more information on how to clean parts, go to **General Maintenance Instructions (page 2-137)**.

10	Oil line (2)	a Using clean rags dampened with solution of detergent and water, wipe clean. b Rinse with clean water. c Using clean, dry rags, wipe dry.
----	--------------	--

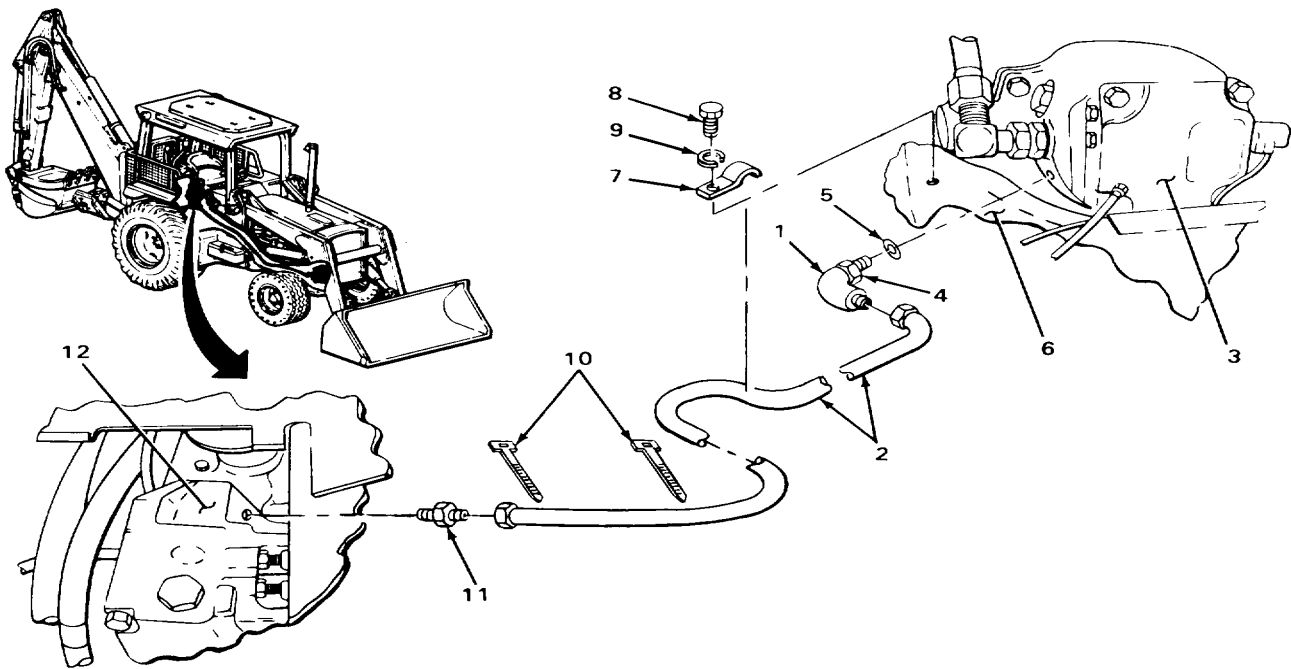

TA243389

HYDRAULIC PUMP-TO-SPEED GEAR ASSEMBLY (REVERSER) SEAL DRAIN LINE - CONTINUED

LOCATION	ITEM	ACTION	REMARKS
----------	------	--------	---------

CLEANING - CONTINUED

WARNING

Drycleaning solvent P-D-680 is toxic and flammable. Wear protective goggles and gloves and use only in a well ventilated area. Avoid contact with skin, eyes, and clothes and don't breathe vapors. Do not use near open flame or excessive heat. The flashpoint is 100°F to 138°F (38° to 59°C). If you become dizzy while using cleaning solvent, get fresh air immediately and get medical aid. If contact with eyes is made, wash your eyes with water and get medical aid immediately.

11	All metal parts	a Clean in drycleaning solvent. b Using clean, dry rags, wipe dry.	
----	-----------------	---	--

INSPECTION/REPLACEMENT

NOTE

For more information on how to inspect parts, go to General Maintenance Instructions (page 2-137). Replace defective parts as needed.

12.	Oil line (1)	Look for cracks and breaks.	
13.	All metal parts	Look for cracks, breaks, and abnormal bends.	
14.	All threaded parts	Look for damaged threads.	

INSTALLATION

15	Speed gear assembly top cover (2)	Straight adapter (3)	a Unplug cover (2). b Screw in and tighten using 7/16-inch open-end wrench.
16	Straight adapter (3)	Oil line (1)	a Take off tag. b Screw on and tighten using two 7/16-inch open-end wrenches.
17	Oil line (1)	Seven new electrical tie down bands (4)	a Place in position at locations noted during removal. b Using slip-joint pliers, tighten.

HYDRAULIC PUMP-TO-SPEED GEAR ASSEMBLY (REVERSER) SEAL DRAIN LINE - CONTINUED

LOCATION	ITEM	ACTION	REMARKS
18	Oil line (1) and front support (5)	Clamp (6)	Place in position.
19	Front support (5) and clamp (6)	Screw (7) and new lockwasher (8)	Screw in and tighten using 9/16-inch, 3/8-inch drive socket, 5-inch extension, and ratchet handle.
20	Elbow (9)	Nut (10)	Screw on all the way.
21		New packing (11)	Place in position.
22	Hydraulic pump (12)	Elbow (9) with assembled parts	a Unplug pump (12). b Screw in and tighten to position noted during removal using 7/16-inch open-end wrench.
23	Hydraulic pump (12) and elbow (9)	Nut (10)	Using 7/16-inch and 1/2-inch open-end wrenches, tighten until seated against pump (12).

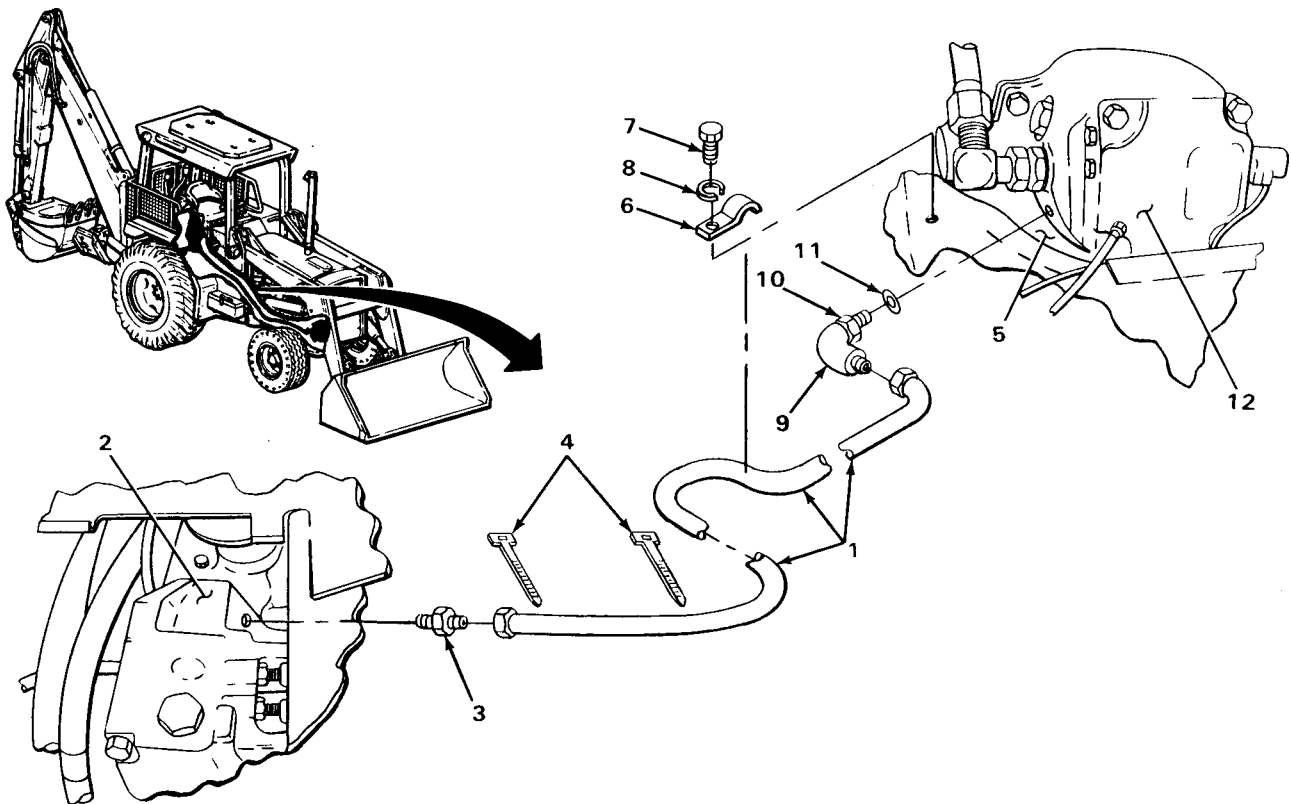

TA243390

HYDRAULIC PUMP-TO-SPEED GEAR ASSEMBLY (REVERSER) SEAL DRAIN LINE - CONTINUED

LOCATION	ITEM	ACTION REMARKS
INSTALLATION - CONTINUED		
24 Elbow (1)	Oil line (2)	a Take off tag. b Screw on and tighten using 7/16-inch open-end wrench.
25 Loader backhoe	Transmission	Check fluid level and add proper amount and grade (TM 5-2420-222-10).
26	Engine	Start and run at high idle (TM 5-2420-222-10).
27	Hydraulic pump-to-speed gear assembly (reverser) seal drain line	a Check for leaks. b If leaking at any connection, tighten using 7/16-inch and 1/2-inch open-end wrenches. c If leaking does not stop, shut down engine (TM 5-2420-222-10) and replace leaking connection packing, fitting, or oil line as outlined in this task. d If found leaking, repeat steps 25 thru 27.
28	Engine	If still running, shut down (TM 5-2420-222-10).

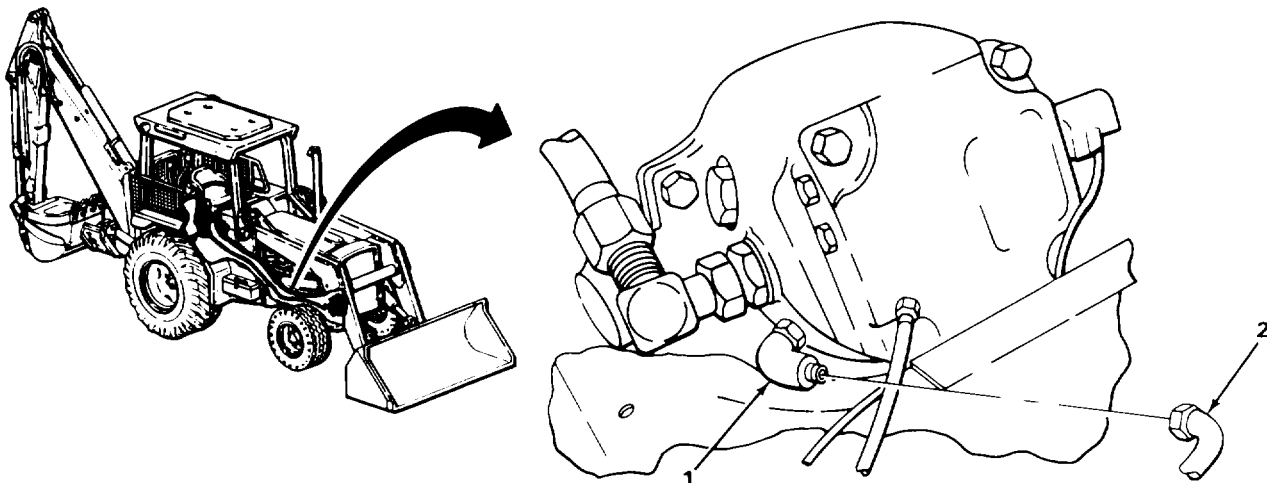

TA243391

HYDRAULIC PUMP-TO-SPEED GEAR ASSEMBLY (REVERSER) SEAL DRAIN LINE - CONTINUED

NOTE

FOLLOW-ON MAINTENANCE:

1. Install right platform (page 2-1079).
2. Install right side grille (TM 5-2420-222-10).

TASK ENDS HERE

HYDRAULIC PUMP-TO-PRESSURE CONTROL VALVE OIL LINE

This task covers:

- | | |
|---|---|
| <ol style="list-style-type: none"> a. Removal (page 2-1376) b. Disassembly (page 2-1378) c. Cleaning (page 2-1378) | <ol style="list-style-type: none"> d. Inspection/Replacement (page 2-1379) e. Assembly (page 2-1380) f. Installation (page 2-1380) |
|---|---|

INITIAL SETUP

Tools

Extension, 1/2-inch drive, 5-inch
 Handle, ratchet, 1/2-inch drive
 Knife, pocket
 Pan, drain
 Socket, 1/2-inch drive, 7/16-inch
 Socket, 1/2-inch drive, 1/2-inch
 Socket, 1/2-inch drive, 9/16-inch
 Vise, machinist's
 Wrench, open-end, 7/16-inch
 Wrench, open-end, 1/2-inch
 Wrench, open-end, 3/4-inch
 Wrench, open-end, 7/8-inch
 Wrench, open-end, 1 1/4-inch
 Wrench, open-end, 1 3/8-inch
 (two required)
 Wrench, torque, 1/2-inch drive,
 0 to 150 foot-pound capacity

Materials/Parts

Lockwasher, bracket screw (two required)
 Lockwasher, clamp screw (two required)
 Packing, hydraulic pump connector
 Packing, pressure control valve connector
 Rags, wiping (item 21, Appendix C)
 Solvent, drycleaning (item 28, Appendix C)
 Tags, marking (item 30, Appendix C)

Personnel Required

One

Equipment Condition

1. Air cleaner removed (page 2-237)
2. Hydraulic oil cooler removed
(page 2-841)
3. Hydraulic oil filter removed
(page 2-1698)
4. Pressure control valve-to-loader control
valve oil line removed (page 2-1647)

HYDRAULIC PUMP-TO-PRESSURE CONTROL VALVE OIL LINE - CONTINUED

LOCATION	ITEM	ACTION REMARKS
REMOVAL		
1 Tee (1)	Oil line (2)	a Place drain pan underneath. b Using 1 1/4-inch and 1 3/8-inch open-end wrenches, unscrew and take off. c Tag (page 2-137).
2 Two hose clamps (3)	Two screws (4), washers (5), and nuts (6)	Using 7/16-inch, 1/2-inch drive socket, ratchet handle, and 7/16-inch open-end wrench, unscrew and take apart.
3 Two clamps (7 and 8) and five oil lines (9, 10, 11, and 12)	Two hose clamps (3)	Take off.
4 Elbow (13), clamp (7), and tee (1)	Oil line (2)	a Place drain pan underneath. b Using 1 3/8-inch open-end wrench, unscrew and take off. c Take out. d Tag (page 2-137).
5 Connector (14)	Elbow (13)	a Note relative position for proper placement during installation. b Using two 1 3/8-inch open-end wrenches, unscrew and take off.
6 Hydraulic pump (15)	Connector (14) with assembled packing (16)	a Using 1 3/8-inch open-end wrench, unscrew and take out. b Plug pump (15) (page 2-137)
7 Connector (14)	Packing (16)	a Using pocket knife, take off. b Get rid of.
8 Tee (1)	Hose (17)	a Place drain pan underneath. b Using 3/4-inch and 7/8-inch open-end wrenches, unscrew and take off. c Plug (page 2-137). d Tag (page 2-137).
9 Connector (18) and clamp (8)	Oil line (9) with assembled tee (1)	a Using two 1 3/8-inch open-end wrenches, unscrew and take off. b Take off. c Tag (page 2-137).

HYDRAULIC PUMP-TO-PRESSURE CONTROL VALVE OIL LINE - CONTINUED

LOCATION	ITEM	ACTION	REMARKS
10 Pressure control valve (19)	Connector (18) with assembled packing (20)	a Using 1 3/8-inch open-end wrench, unscrew and take out. b Plug valve (19) (page 2-137) c Get rid of drained fluid (page 2-137).	
11 Connector(18)	Packing (20)	a Using pocket knife, take off. b Get rid of.	

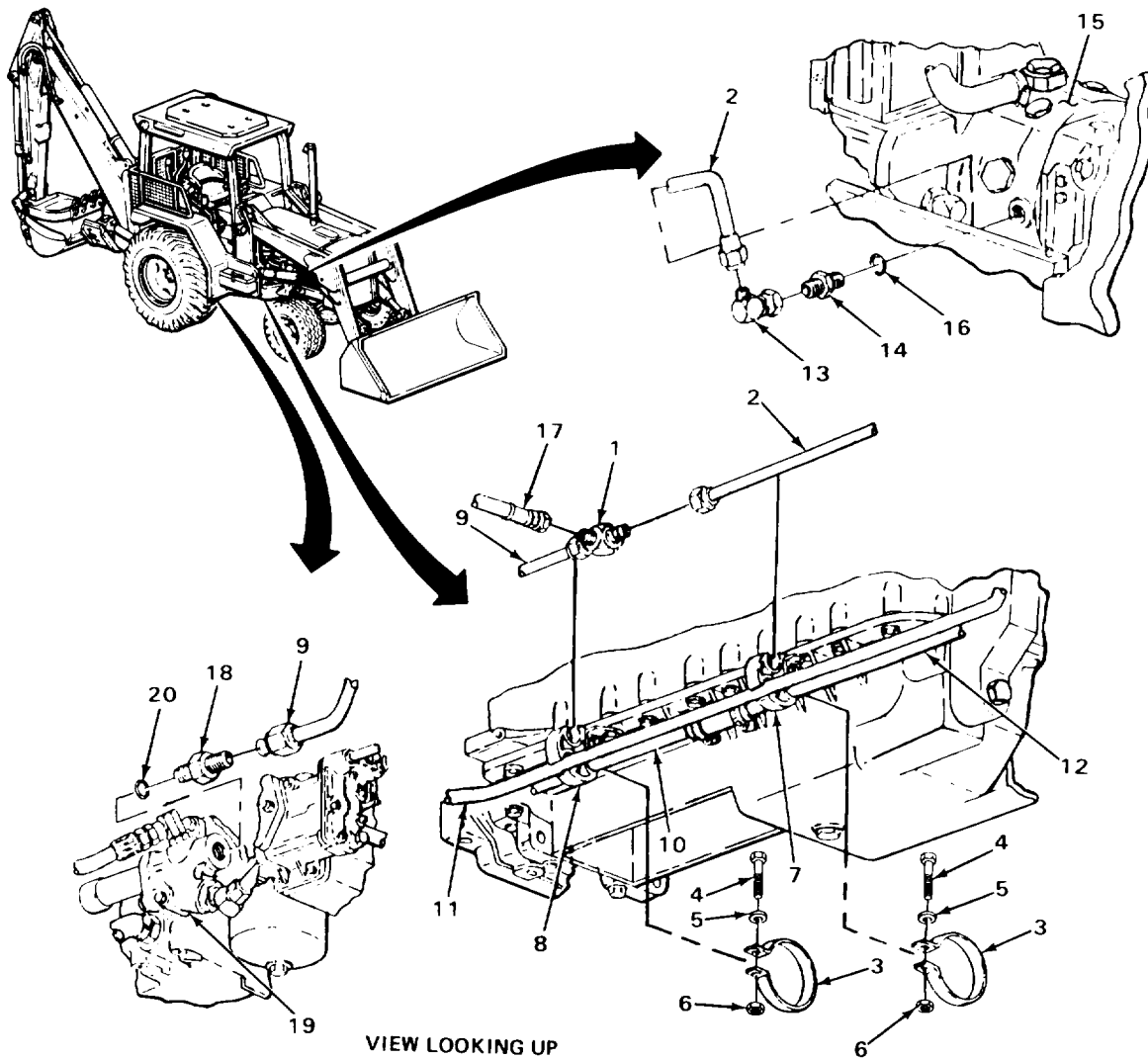

TA243392

HYDRAULIC PUMP-TO-PRESSURE CONTROL VALVE OIL LINE - CONTINUED

LOCATION	ITEM	ACTION	REMARKS
REMOVAL - CONTINUED			
NOTE			
Oil line mounting brackets and clamps support five oil lines. Do not remove brackets or clamps unless inspection shows need for replacement.			
12 Two clamps (1 and 2) and two brackets (3)	Two screws (4), lockwashers (5), and nuts (6)	a Using 1/2-inch, 1/2-inch drive socket, ratchet handle, and 1/2-inch open-end wrench, unscrew and take apart. b Get rid of lockwashers (5).	
13 Two brackets (3) and three oil lines (7 thru 9)	Two clamps (1 and 2)	Take off.	
14 Two brackets (3), oil pan (10), and engine block (11)	Two screws (12), and lockwashers (13)	a Using 9/16-inch, 1/2-inch drive socket, 5-inch extension, and ratchet handle, unscrew and take out. b Get rid of lockwashers (13).	
15 Oil pan (10)	Two brackets (3)	Take off.	
DISASSEMBLY			
16 Tee (14)	Oil line (15)	a Place tee (14) in machinist's vise. b Note relative position for proper placement during assembly. c Using 1 3/8-inch open-end wrench, unscrew and take off. d Take tee (14) out of machinist's vise.	

CLEANING**NOTE**

For more information on how to clean parts, go to General Maintenance Instructions (page 2-137).

HYDRAULIC PUMP-TO-PRESSURE CONTROL VALVE OIL LINE - CONTINUED

LOCATION	ITEM	ACTION	REMARKS
----------	------	--------	---------

WARNING

Drycleaning solvent P-D-680 is toxic and flammable. Wear protective goggles and gloves and use only in a well ventilated area. Avoid contact with skin, eyes, and clothes and don't breathe vapors. Do not use near open flame or excessive heat. The flashpoint is 100°F to 138°F (38° to 59°C). If you become dizzy while using cleaning solvent, get fresh air immediately and get medical aid. If contact with eyes is made, wash your eyes with water and get medical aid immediately.

17	All metal parts	a Clean in drycleaning solvent. b Using clean, dry rags, wipe dry.
----	-----------------	---

INSPECTION/REPLACEMENT

NOTE

For more information on how to inspect parts, go to General Maintenance Instructions (page 2-137).

Replace defective parts as needed.

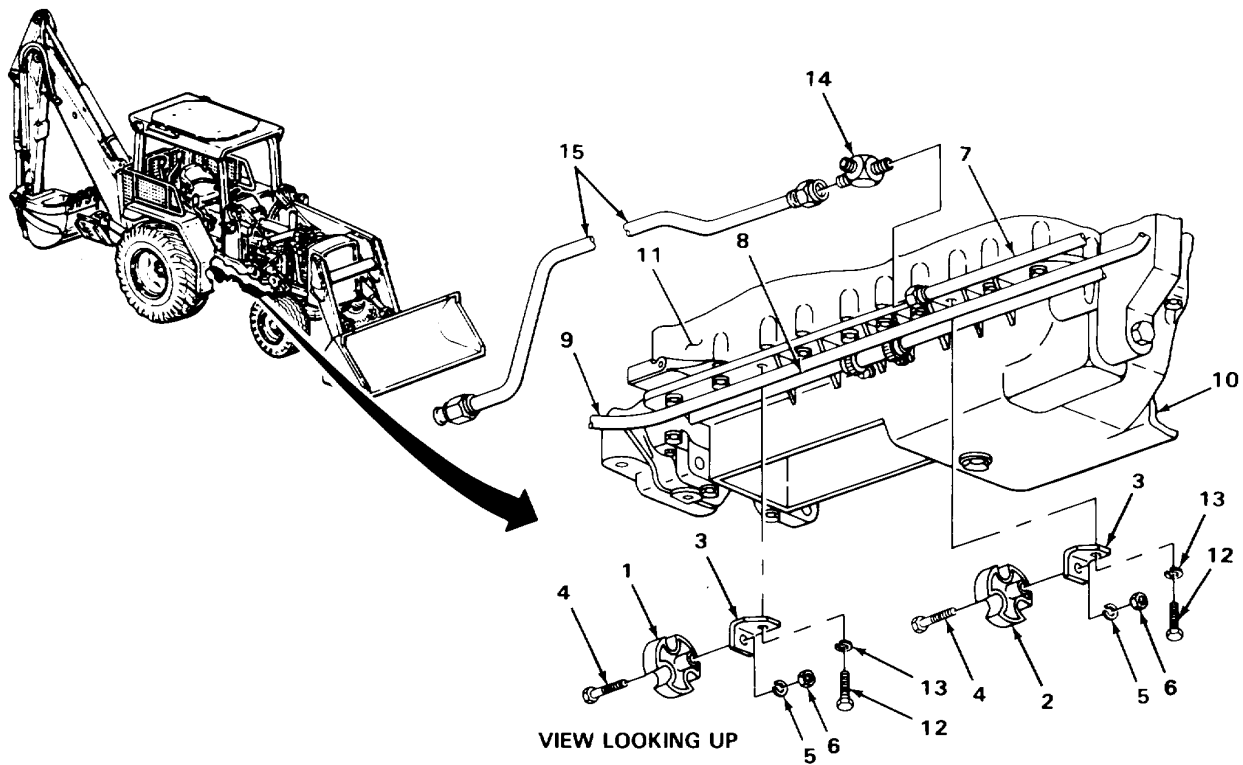

TA243393

HYDRAULIC PUMP-TO-PRESSURE CONTROL VALVE OIL LINE - CONTINUED

LOCATION	ITEM	ACTION REMARKS
INSPECTION/REPLACEMENT- CONTINUED		
18	All metal parts	Look for cracks, breaks, and abnormal bends.
19	All threaded parts	Look for damaged threads.
ASSEMBLY		
20 Tee (1)	Oil line (2)	<ul style="list-style-type: none"> a Place tee (1) in machinist's vise. b Screw on and tighten to position noted during disassembly using 1 3/8-inch open-end wrench. c Take tee (1) out of machinist's vise.

INSTALLATION**NOTE**

If oil line mounting brackets and clamps were not take off during removal, skip steps 21 thru 24.

21. Oil pan (3)	Two brackets (4)	Place in position.
22. Two brackets (4), oil pan (3), and engine block (5)	Two screws (6) and new lockwashers (7)	<ul style="list-style-type: none"> a Screw in and tighten until snug using 9/16-inch, 1/2-inch drive socket, 5-inch extension, and ratchet handle. b Using 9/16-inch, 1/2-inch drive socket, 5-inch extension, and 0 to 150 foot-pound torque wrench, tighten to 50 foot-pounds (68 N•m) torque.
23 Two brackets (4) and three oil lines (8 thru 10)	Two clamps (11 and 12)	Place in position.
24 Two clamps (11 and 12) and two brackets (4)	Two screws (13), new lockwashers (14), and nuts (15)	Screw together and tighten using 1/2-inch, 1/2-inch drive socket, ratchet handle, and 1/2-inch open-end wrench.

HYDRAULIC PUMP-TO-PRESSURE CONTROL VALVE OIL LINE - CONTINUED

LOCATION	ITEM	ACTION	REMARKS
25. Connector (16)	New packing (17)	Place in position.	
26. Pressure control valve (18)	Connector (16) with assembled packing (17)	a Unplug valve (18). b Screw in and tighten using 1 3/8-inch open-end wrench.	
27. Connector (16) and clamp (11)	Oil line (2) with assembled tee (1)	a Take off tag. b Place in position. c Screw onto connector (16) and tighten using two 1 3/8-inch open-end wrenches.	

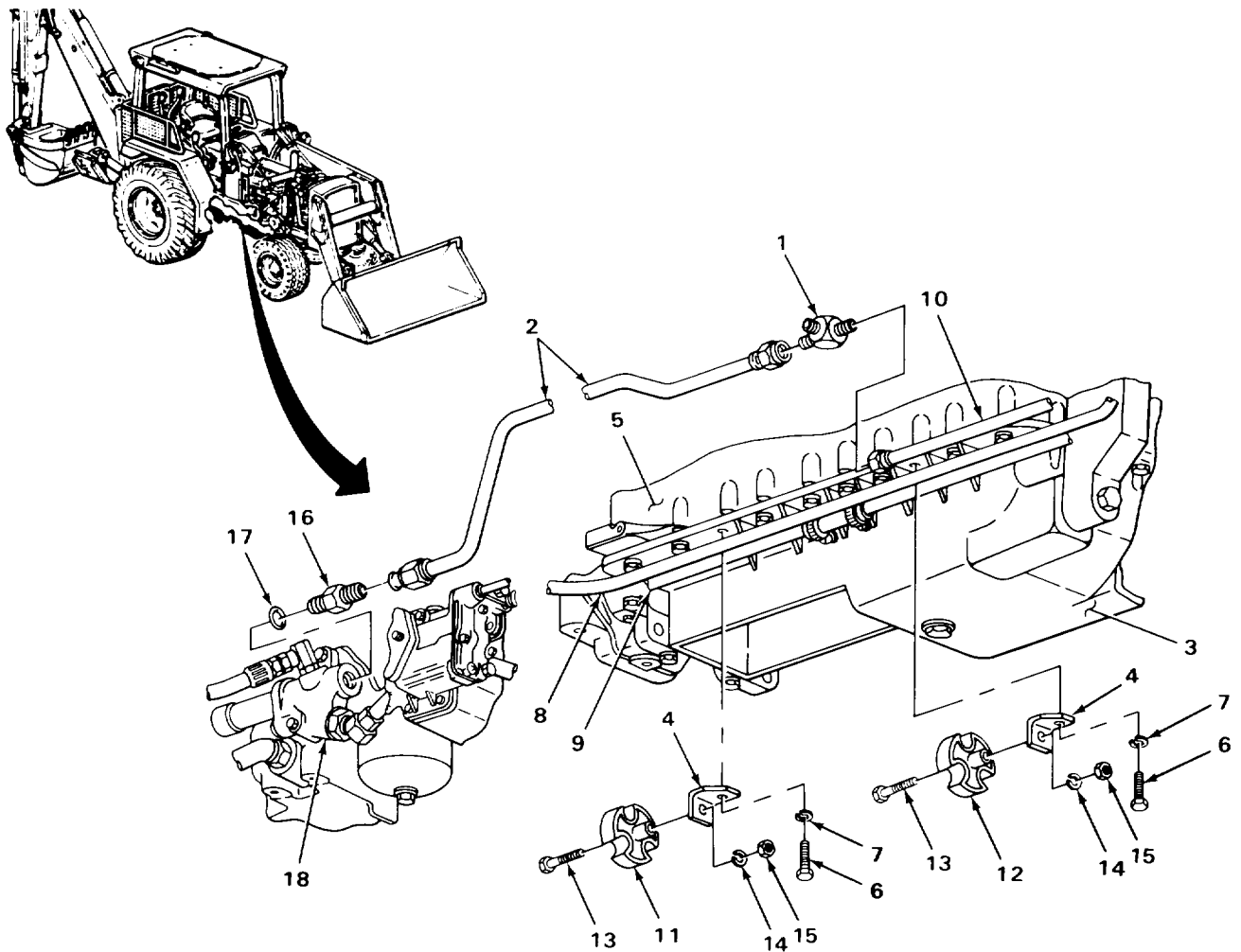

TA243394

HYDRAULIC PUMP-TO-PRESSURE CONTROL VALVE OIL LINE - CONTINUED

LOCATION	ITEM	ACTION REMARKS
INSTALLATION - CONTINUED		
28	Tee (1) Hose (2)	a Take off tag. b Unplug. c Screw on and tighten using 3/4-inch and 7/8-inch open-end wrenches.
29.	Connector (3) New packing (4)	Place in position.
30.	Hydraulic pump (5) Connector (3) with assembled packing (4)	Screw in and tighten using 1 3/8-inch open-end wrench.
31	Connector (3) Elbow (6)	Screw on to same relative position noted during removal using two 1 3/8-inch open-end wrenches.
32	Elbow (6), clamp (7), and tee (1) Oil line (8)	a Takeoff tag. b Place in position. c Screw onto elbow (6) and tighten using 1 3/8-inch open-end wrench.
33	Two clamps (7 and 9) and five oil lines (8, 10, 11, 12, and 13) Two hose clamps (14)	Place in position.
34	Two hose clamps (14) washers (16), and nuts (17) Two screws (15),	Screw together and tighten using 7/16-inch, 1/2-inch drive socket, ratchet handle, and 7/16-inch open-end wrench.
35	Tee (1) Oil line (8)	a Take off tag. b Screw on and tighten using 1 1/4-inch and 1 3/8-inch open-end wrenches.
36	Loader backhoe Hydraulic oil filter	Install (page 2-1698).
37.	Pressure control valve-to-loader control valve oil line	Install (page 2-1647).
38.	Hydraulic oil cooler	Install (page 2-841).
39.	Air cleaner	Install (page 2-237). Do not install right side grille at this time.

HYDRAULIC PUMP-TO-PRESSURE CONTROL VALVE OIL LINE - CONTINUED

LOCATION	ITEM	ACTION	REMARKS
40	Transmission		Check fluid level and add proper amount and grade (TM 5-2420-222-10).
41	Engine		Start and run at high idle (TM 5-2420-222-10).
42	Hydraulic pump-to-pressure control valve oil line	<ul style="list-style-type: none"> a Check for leaks. b If leaking at any connection, tighten using 3/4-inch, 7/8-inch, 1 1/4-inch, and two 1 3/8-inch open-end wrenches. 	

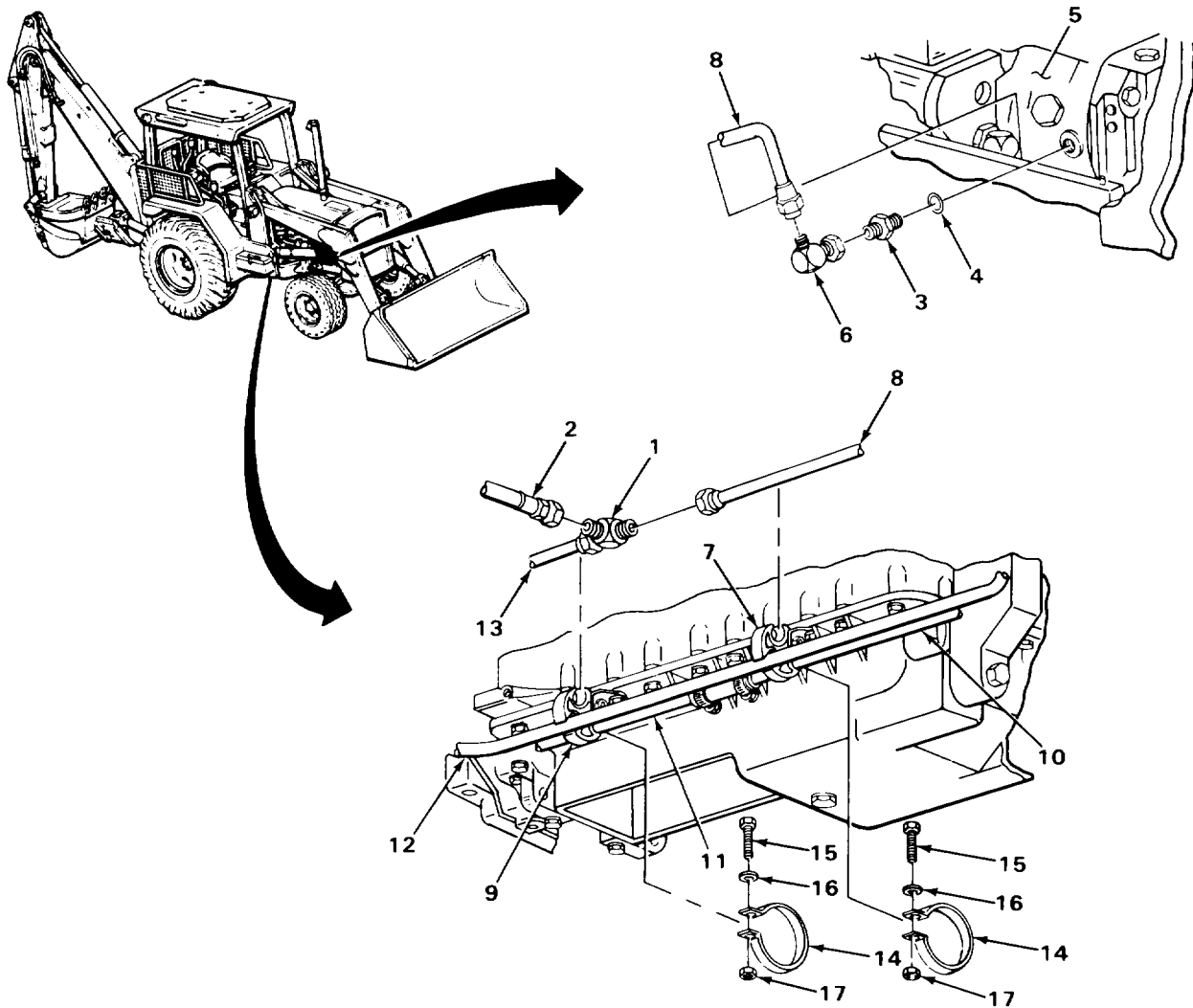

TA243395

HYDRAULIC PUMP-TO-PRESSURE CONTROL VALVE OIL LINE - CONTINUED

LOCATION	ITEM	ACTION	REMARKS
INSTALLATION - CONTINUED			
42 Continued	Hydraulic pump-to-pressure control valve oil line	c If leaking does not stop, shut down engine (TM 5-2420-222-10) and replace defective packing, fitting, or oil line as outlined in this task. d If found leaking, repeat steps 40 thru 42.	
43	Engine	If still running, shut down (TM 5-2420-222-10).	

NOTE

FOLLOW-ON MAINTENANCE: Install right side grille (TM 5-2420-222-10).

TASK ENDS HERE

HYDRAULIC PUMP PRESSURE LINE TEE-TO-HYDRAULIC ACCUMULATOR OIL LINE

This task covers:

- | | |
|---------------------------|---|
| a. Removal (page 2-1385) | c. Inspection/Replacement (page 2-1388) |
| b. Cleaning (page 2-1386) | d. Installation (page 2-1388) |

INITIAL SETUP

Tools

- Knife, pocket
- Pan, drain
- Wrench, box, 9/16-inch
- Wrench, open-end, 3/4-inch
- Wrench, open-end, 7/8-inch

NOTE

The following tool only applies to loader backhoes with Serial Numbers 235786 thru 235999.

- Wrench, open-end

Materials/Parts

- Detergent, GP (item 7, Appendix C)
- Lockwasher, accumulator bracket screw
- Packing, accumulator tee
- Rags, wiping (item 21, Appendix C)
- Solvent, drycleaning (item 28, Appendix C)
- Tags, marking (item 30, Appendix C)

Personnel Required

One

Equipment Condition

Hydraulic system pressure released (page 2-1191)

HYDRAULIC PUMP PRESSURE LINE TEE-TO-HYDRAULIC ACCUMULATOR OIL LINE - CONTINUED

LOCATION	ITEM	ACTION	REMARKS
----------	------	--------	---------

REMOVAL

WARNING

Do not attempt to disconnect hydraulic lines and fittings while engine is running or before hydraulic system pressure has been released. When engine is running, hydraulic system is under pressure. Hydraulic system pressure should be 0 psi (0 kPa) before lines are disconnected. A line or fitting disconnected under pressure will blow off with a lot of force and could cause serious injury to personnel.

Be careful when draining hot fluids. Wear gloves to protect your hands from hot parts and fluids or severe burns could result.

- | | | |
|----------------------|----------|--|
| 1 Two tees (1 and 2) | Hose (3) | <ul style="list-style-type: none"> a Place drain pan underneath. b Using 7/8-inch open-end wrench, unscrew and take off. c Tag (page 2-137). d Cap tee (1) (page 2-137). |
|----------------------|----------|--|

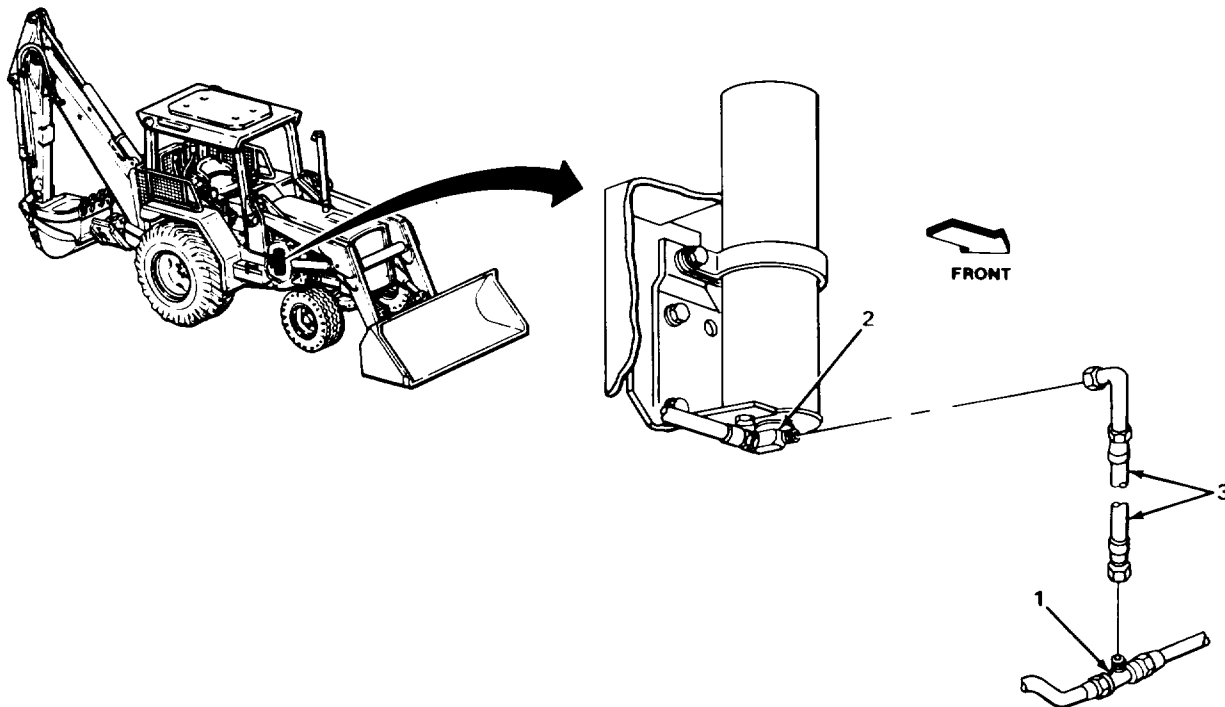

TA243396

HYDRAULIC PUMP PRESSURE LINE TEE-TO-HYDRAULIC ACCUMULATOR OIL LINE - CONTINUED

LOCATION	ITEM	ACTION	REMARKS
REMOVAL - CONTINUED			
NOTE			
Steering valve-to-accumulator tee steering hoses on loader backhoes with Serial Numbers 235786 thru 235999 are different configuration from those with Serial Numbers 319995 thru 342573.			
2	Tee (1)	Hose (2 or 3)	<ul style="list-style-type: none"> a Place drain pan underneath. b On loader backhoes with Serial Numbers 235786 thru 235999, using open-end wrench, unscrew and take off. c On loader backhoes with Serial Numbers 319995 thru 342573, using 3/4-inch open-end wrench, unscrew and take off. d Tag (page 2-137). e Plug (page 2-137).
3	Accumulator (4) and bracket (5)	Screw (6) and lockwasher (7)	<ul style="list-style-type: none"> a Using 9/16-inch box wrench, unscrew and take out. b Get rid of lockwasher (7).
4	Accumulator (4) and tee (1)	Nut (8)	Using 3/4-inch and 7/8-inch open-end wrenches, loosen.
5	Accumulator (4)	Tee (1) with assembled parts and orifice (9) with assembled spring (10)	<ul style="list-style-type: none"> a Note relative position for proper placement during installation. b Using 3/4-inch open-end wrench, unscrew tee (1) and take out. c Plug accumulator (4). d Get rid of drained fluid (page 2-137).
6	Tee (1)	Packing (11)	<ul style="list-style-type: none"> a Using pocket knife, take off. b Get rid of.

CLEANING**NOTE**

For more information on how to clean parts, go to **General Maintenance Instructions (page 2-137)**.

HYDRAULIC PUMP PRESSURE LINE TEE-TO-HYDRAULIC ACCUMULATOR OIL LINE - CONTINUED

LOCATION	ITEM	ACTION	REMARKS
7	Hose (12)	a. Using clean rags dampened in solution of detergent and water, wipe clean. b. Rinse with clean water. c. Using clean, dry rags, wipe dry.	

WARNING

Drycleaning solvent P-D-680 is toxic and flammable. Wear protective goggles and gloves and use only in a well ventilated area. Avoid contact with skin, eyes, and clothes and don't breathe vapors. Do not use near open flame or excessive heat. The flashpoint is 100°F to 138°F (38° to 59°C). If you become dizzy while using cleaning solvent, get fresh air immediately and get medical aid. If contact with eyes is made, wash your eyes with water and get medical aid immediately.

8	All metal parts	a. Clean in drycleaning solvent. b. Using clean, dry rags, wipe dry.	
---	-----------------	---	--

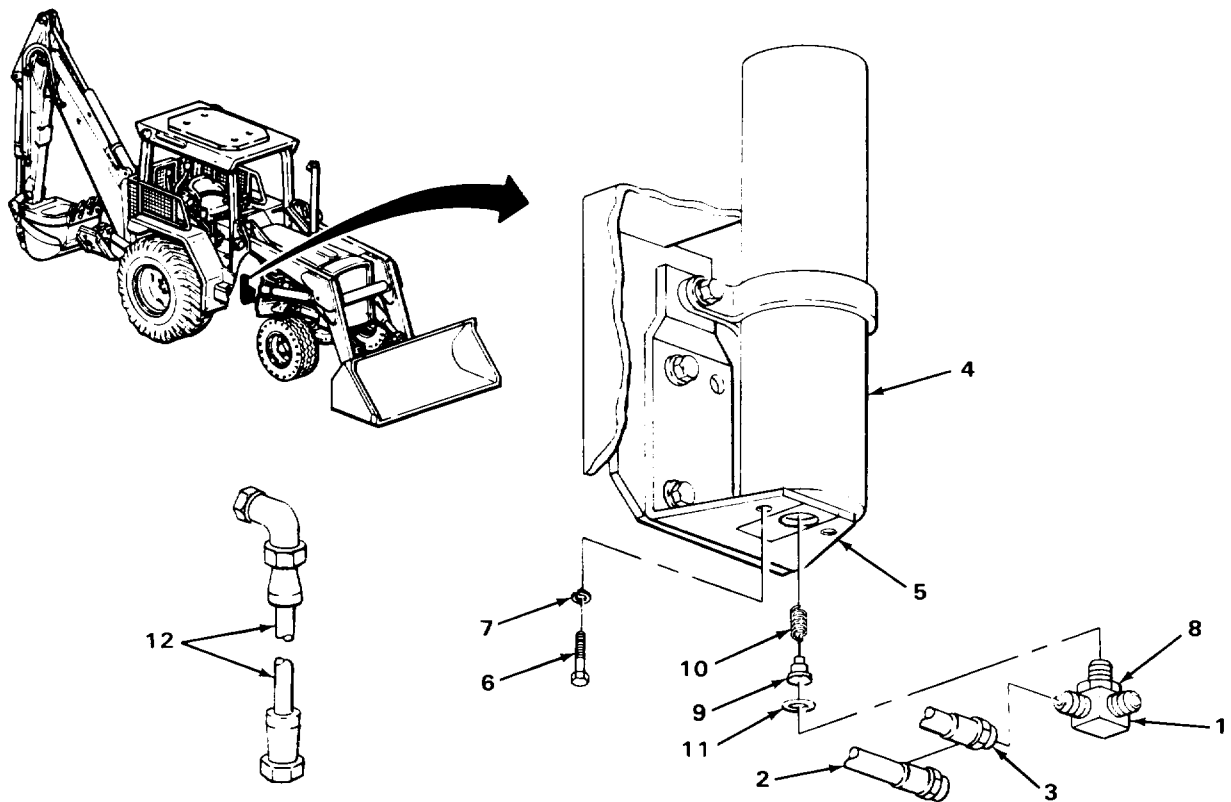

TA243397

HYDRAULIC PUMP PRESSURE LINE TEE-TO-HYDRAULIC ACCUMULATOR OIL LINE - CONTINUED

LOCATION	ITEM	ACTION	REMARKS
INSPECTION/REPLACEMENT			
NOTE			
For more information on how to inspect parts, go to General Maintenance Instructions (page 2-137) .			
Replace defective parts as needed.			
9.	Hose (1)		Look for cracks, breaks, and tears.
10.	All metal parts		Look for cracks and breaks
11.	All threaded parts		Look for damaged threads.
INSTALLATION			
12	Tee (2)	Nut (3)	Screw on all the way.
13.		New packing (4)	Place in position.
14	Accumulator (5)	Tee (2) with assembled parts and orifice (6) with assembled spring (7)	a Unplug accumulator (5). b Screw in and tighten tee (2) to same position noted during removal using 3/4-inch open-end wrench.
15	Accumulator (5) and tee (2)	Nut (3)	Using 3/4-inch and 7/8-inch open-end wrenches, tighten until seated against accumulator (5).
16	Accumulator (5) and bracket (8)	Screw (9) and new lockwasher (10)	Screw in and tighten using 9/16-inch box wrench.

NOTE

Steering valve-to-accumulator tee steering hoses on loader backhoes with Serial Numbers 235786 thru 235999 are different configuration from those with Serial Numbers 319995 thru 342573.

HYDRAULIC PUMP PRESSURE LINE TEE-TO-HYDRAULIC ACCUMULATOR OIL LINE - CONTINUED

LOCATION	ITEM	ACTION REMARKS
17 Tee (2)	Hose (11 or 12)	a Take off tag. b Unplug. c On loader backhoes with Serial Numbers 235786 thru 235999, screw on and tighten using open-end wrench. d On loader backhoes with Serial Numbers 319995 thru 342573, screw on and tighten using 3/4-inch open-end wrench.
18 Two tees (2 and 13)	Hose (1)	a Uncap tee (13). b Take off tag. c Screw on and tighten using 7/8-inch open-end wrench.
19 Loader backhoe	Transmission	Check fluid level and add proper amount and grade (TM 5-2420-222-10).

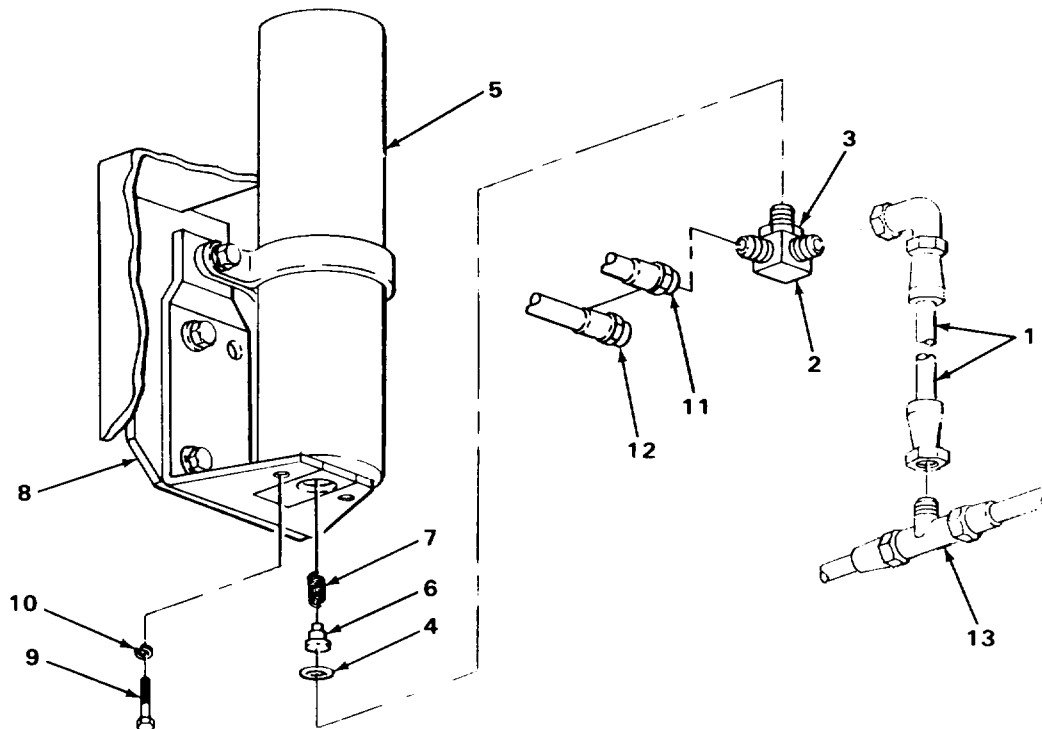

TA243398

HYDRAULIC PUMP PRESSURE LINE TEE-TO-HYDRAULIC ACCUMULATOR OIL LINE - CONTINUED

LOCATION	ITEM	ACTION	REMARKS
INSTALLATION - CONTINUED			
20	Loader backhoe	Engine	Start and run at high idle (TM 5-2420-222-10).
21	Hydraulic pump pressure line tee-to-hydraulic accumulator oil line		<ul style="list-style-type: none"> a Check for leaks. b If leaking at any connection, tighten using 3/4-inch and 7/8-inch open-end wrenches. c If leaking does not stop, shut down engine (TM 5-2420-222-10) and replace leaking connection packing, fitting, or hose as outlined in this task. d If found leaking, repeat steps 19 thru 21.
22		Engine	If still running, shut down (TM 5-2420-222-10).

TASK ENDS HERE

JAW CONTROL (DIRECT LINEAR) VALVE TUBES AND FITTINGS

This task covers:

- | | |
|---|--|
| <ul style="list-style-type: none"> a Removal (page 2-1392) b Cleaning (page 2-1394) | <ul style="list-style-type: none"> c Inspection/Replacement (page 2-1395) d Installation (page 2-1396) |
|---|--|
-

INITIAL SETUP

Tools

- Caps, vise jaw (pair)
- Knife, pocket
- Pan, drain
- Vise, machinist's
- Wrench, open-end, 7/16-inch
- Wrench, open-end, 1/2-inch
- Wrench, open-end, 5/8-inch

Materials/Parts

- Rags, wiping (item 21, Appendix C)
- Solvent, drycleaning (item 28, Appendix C)..
- Tags, marking (item 30, Appendix C)

NOTE

The following part only applies to loader backhoses with Serial Numbers 235786 thru 235999.

- Packing, straight adapter

Personnel Required

One

Equipment Condition

- 1 Hydraulic system pressure released (page 2-1191)
- 2 Right platform removed (page 2-1079)

NOTE

The following only applies to loader backhoes with Serial Numbers 235786 thru 235999.

- 3 Rear platform removed (page 2-1117)

NOTE

The following only applies to loader backhoes with Serial Numbers 319995 thru 342573.

- 4 Left rear platform removed (page 2-1114)

JAW CONTROL (DIRECT LINEAR) VALVE TUBES AND FITTINGS - CONTINUED

LOCATION	ITEM	ACTION	REMARKS
----------	------	--------	---------

REMOVAL

WARNING

Do not attempt to disconnect hydraulic lines and fittings while engine is running or before hydraulic system pressure has been released. When engine is running, hydraulic system is under pressure. Hydraulic system pressure should be 0 psi (0 kPa) before lines are disconnected. A line or fitting disconnected under pressure will blow off with a lot of force and could cause serious injury to personnel.

Be careful when draining hot fluids. Wear gloves to protect your hands from hot parts and fluids or severe burns could result.

1	Tee (1) and elbow (2)	Tube (3)	<ul style="list-style-type: none"> a Place drain pan underneath. b Using 7/16-inch open-end wrench, unscrew and take off. c Tag (page 2-137).
2	Tee (1) and elbow (4)	Tube (5)	<ul style="list-style-type: none"> a Using 7/16-inch open-end wrench, unscrew and take off. b Tag (page 2-137).

NOTE

Steps 3 thru 5 only apply to loader backhoes with Serial Numbers 235786 thru 235999.

3	Straight adapter (6)	Elbow (7) with assembled parts	<ul style="list-style-type: none"> a Using open-end wrenches, unscrew and take off. b Plug (page 2-137).
4	Valve (8)	Straight adapter (6) with assembled packing (9)	<ul style="list-style-type: none"> a Using open-end wrench, unscrew and take out. b Plug valve (8).
5	Straight adapter (6)	Packing (9)	<ul style="list-style-type: none"> a Using pocket knife, take off. b Get rid of.
6	Valve (8)	Tee (1)	<ul style="list-style-type: none"> a Note relative position for proper placement during assembly. b Using 1/2-inch open-end wrench, unscrew and take out. c Plug valve (8).

JAW CONTROL (DIRECT LINEAR) VALVE TUBES AND FITTINGS - CONTINUED

LOCATION	ITEM	ACTION	REMARKS
7. Valve (8)	Elbow (4)	a. Note relative position for proper placement during installation. b. Using 1/2-inch open-end wrench, unscrew and take out. c. Plug valve (8) (page 2-137).	
8. Check valve (10)	Elbow (2)	a. Note relative position for proper placement during installation. b. Using 1/2-inch and 5/8-inch open-end wrenches, unscrew and take out.	

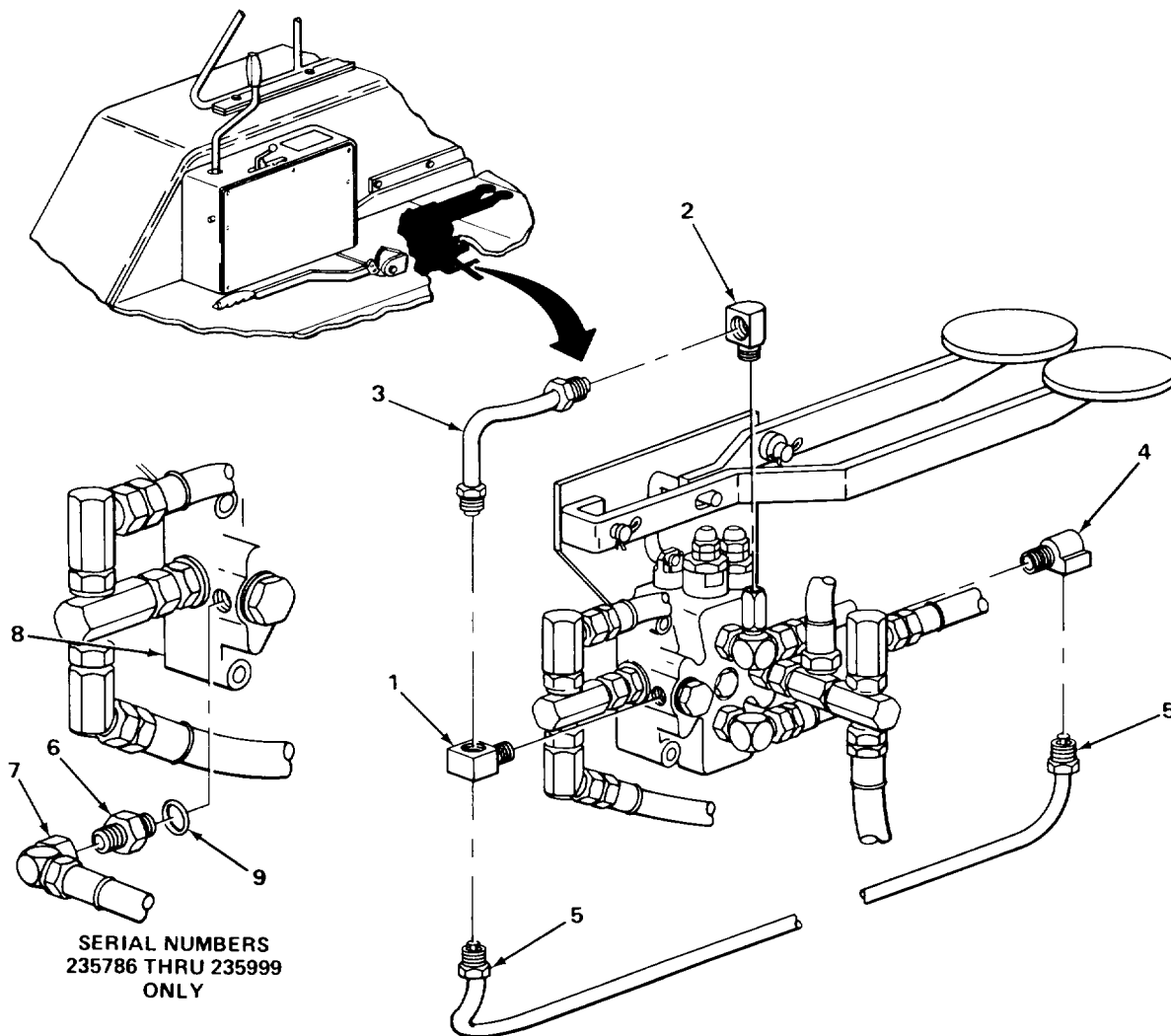

JAW CONTROL (DIRECT LINEAR) VALVE TUBES AND FITTINGS - CONTINUED

LOCATION	ITEM	ACTION	REMARKS
----------	------	--------	---------

REMOVAL - CONTINUED

- | | | | |
|-----------------------|---|---|--|
| 9. Bulkhead elbow (1) | Check valve (2)
with assembled
nipple (3) | <ul style="list-style-type: none"> a. Using 5/8-inch open-end wrench, unscrew and take out. b. Cap elbow (1) (page 2-137). c. Get rid of drained fluid (page 2-137). | |
|-----------------------|---|---|--|

CAUTION

Do not remove nipple from check valve unless inspection shows need for replacement. Removal may damage threads on nipple.

- | | | | |
|----------------|-----------------|---|--|
| 10. Nipple (3) | Check valve (2) | <ul style="list-style-type: none"> a. Place nipple (3) in machinist's vise with vise jaw caps. b. Using 5/8-inch open-end wrench, unscrew and take off. c. Take nipple (3) out of machinist's vise with vise jaw caps. | |
|----------------|-----------------|---|--|

CLEANING

NOTE

For more information on how to clean parts, go to General Maintenance Instructions (page 2-137).

WARNING

Dry cleaning solvent P-D-680 is toxic and flammable. Wear protective goggles and gloves and use only in a well ventilated area. Avoid contact with skin, eyes, and clothes and don't breathe vapors. Do not use near open flame or excessive heat. The flashpoint is 100°F to 138°F (38° to 59°C). If you become dizzy while using cleaning solvent, get fresh air immediately and get medical aid. If contact with eyes is made, wash your eyes with water and get medical aid immediately.

- | | | | |
|-----|-----------------|--|--|
| 11. | All metal parts | <ul style="list-style-type: none"> a. Clean in dry cleaning solvent. b. Using clean, dry rags, wipe dry. | |
|-----|-----------------|--|--|

JAW CONTROL (DIRECT LINEAR) VALVE TUBES AND FITTINGS - CONTINUED

LOCATION	ITEM	ACTION	REMARKS
----------	------	--------	---------

INSPECTION/REPLACEMENT

NOTE

For more information on how to inspect parts, go to General Maintenance Instructions (page 2-137).

Replace defective parts as needed.

- | | | |
|-----|-----------------|---|
| 12. | All metal parts | <ul style="list-style-type: none"> a. Look for cracks, breaks, and abnormal bends. b. Look for damaged threads. |
|-----|-----------------|---|

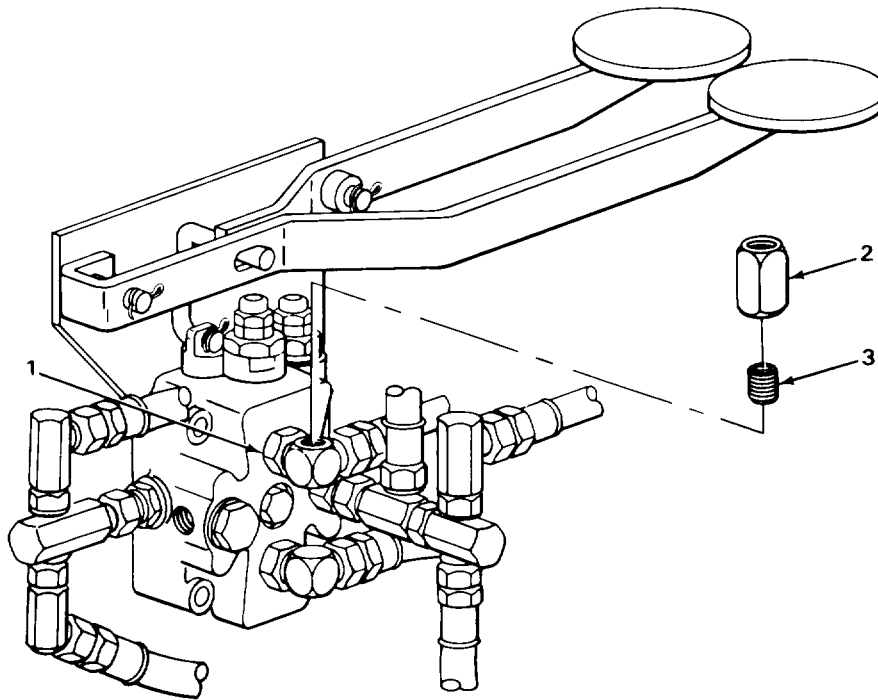

TA243400

JAW CONTROL (DIRECT LINEAR) VALVE TUBES AND FITTINGS - CONTINUED

LOCATION	ITEM	ACTION	REMARKS
INSTALLATION			
NOTE			
If nipple was removed from check valve, make certain that arrow on check valve points toward nipple when installed. If check valve is installed backwards, jaw control (direct linear) valve will not operate properly.			
13.	Nipple (1)	Check valve (2)	Screw on as far as possible with arrow pointing toward nipple (1).
14.	Bulkhead elbow (3)	Check valve (2) with assembled nipple (1)	a. Uncap elbow (3). b. Screw in and tighten using 5/8-inch open-end wrench.
15.	Check valve (2)	Elbow (4)	Screw in and tighten to same relative position noted during removal, using 1/2-inch and 5/8-inch open-end wrenches.
16.	Valve (5)	Elbow (6)	a. Unplug valve (5). b. Screw in and tighten to same relative position noted during removal, using 1/2-inch open-end wrench.
17.		Tee (7)	a. Unplug valve (5). b. Screw in and tighten to same relative position noted during removal, using 1/2-inch open-end wrench.
NOTE			
Steps 18 thru 20 only apply to loader backhoes with Serial Numbers 235786 thru 235999.			
18.	Straight adapter (8)	New packing (9)	Place in position.
19.	Valve (5)	Straight adapter (8) with assembled packing (9)	a. Unplug valve (5). b. Screw in and tighten using xx-inch open-end wrench.

JAW CONTROL (DIRECT LINEAR) VALVE TUBES AND FITTINGS - CONTINUED

LOCATION	ITEM	ACTION	REMARKS
----------	------	--------	---------

20. Straight adapter (8)	Elbow (10) with assembled parts	Screw on and tighten using open-end wrenches.	
--------------------------	---------------------------------	---	--

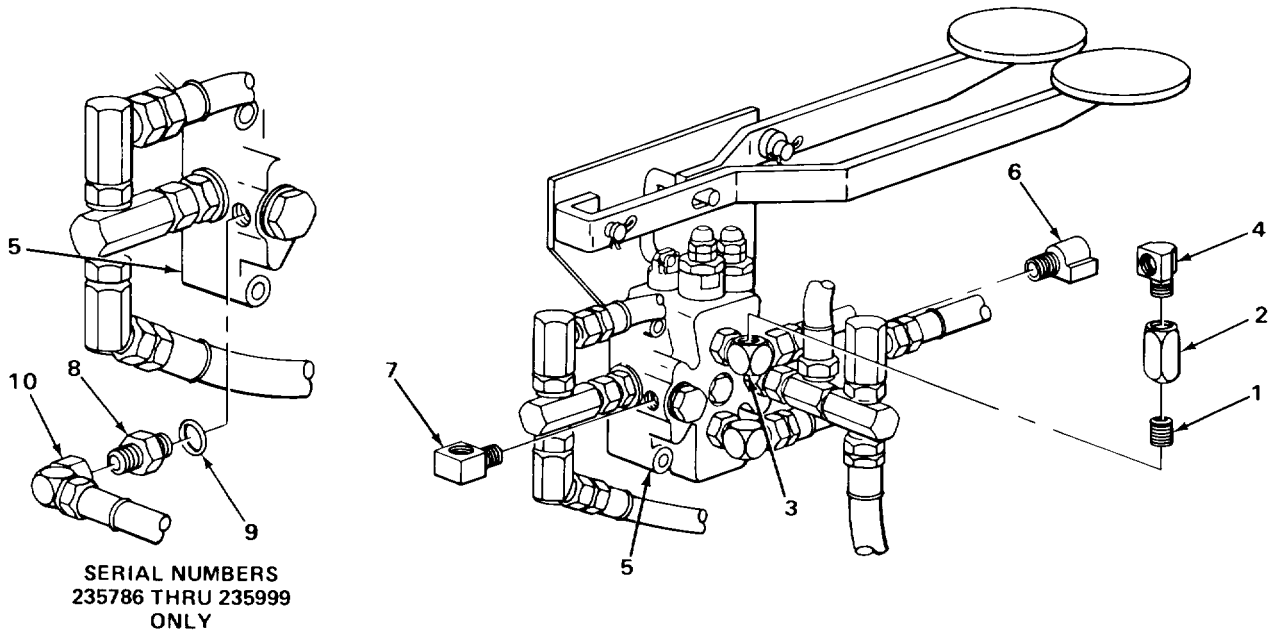

JAW CONTROL (DIRECT LINEAR) VALVE TUBES AND FITTINGS - CONTINUED

LOCATION	ITEM	ACTION REMARKS
INSTALLATION - CONTINUED		
21. Tee (1) and elbow (2)	Tube (3)	a. Take off tag. b. Screw on and tighten using 7/16-inch open-end wrench.
22. Tee (1) and elbow (4)	Tube (5)	a. Take off tag. b. Screw on and tighten using 7/16-inch open-end wrench.
23. Loader backhoe	Transmission	Check fluid level and add proper amount and grade (TM 5-2420-222-10).
24.	Engine	Start and run at high idle (TM 5-2420-222-10).
25.	Jaw control (direct linear) valve tubes and fittings	a. Check for leaks. b. If leaking at any connection, tighten using 7/16-inch, 1/2-inch, and 5/8-inch open-end wrenches. c. If leaking does not stop, shut down engine (TM 5-2420-222-10) and replace leaking connection packing, fitting, or tube as outlined in this task. d. If found leaking, repeat steps 23 thru 25.
26.	Engine	If still running, shut down (TM 5-2420-222-10).

JAW CONTROL (DIRECT LINEAR) VALVE TUBES AND FITTINGS - CONTINUED

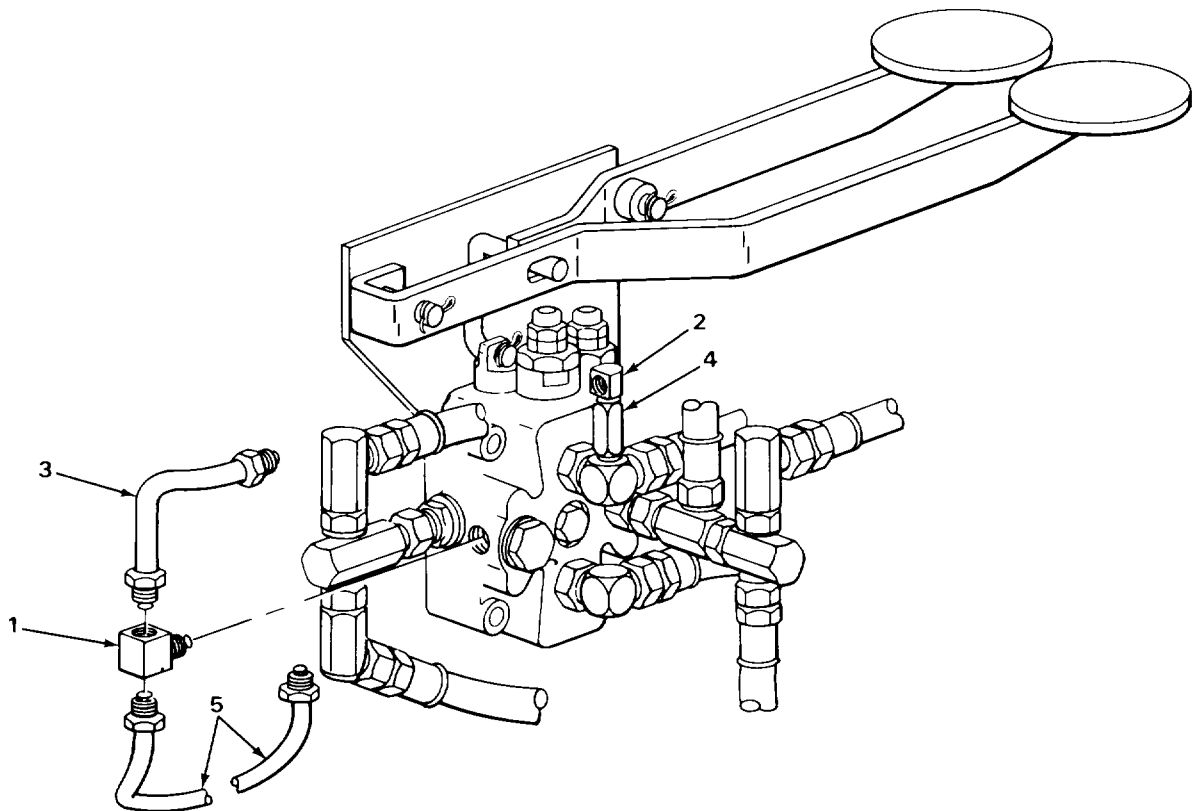

NOTE

FOLLOW-ON MAINTENANCE:

1. Install right platform (page 2-1079).

Perform the following only on loader backhoes with Serial Numbers 235786 thru 235999.

2. Install rear platform (page 2-1117).

Perform the following only on loader backhoes with Serial Numbers 319995 thru 342573.

3. Install left rear platform (page 2-1114).

TASK ENDS HERE

PRESSURE CONTROL VALVE-TO-MANIFOLD OIL LINE (SERIAL NUMBERS 235786 THRU 235999 ONLY)

This task covers:

- a. Removal (page 2-1400)
- b. Cleaning (page 2-1402)
- c. Inspection/Replacement (page 2-1402)
- d. Installation (page 2-1402)

INITIAL SETUP

Tools

Knife, pocket
 Pan, drain
 Wrench, open-end, 1 1/16-inch
 Wrench, open-end, 1 1/4-inch
 (two required)

Materials/Parts - Continued

Packing, union adapter-to-pressure relief valve
 Rags, wiping (item 21, Appendix C)
 Solvent, dry cleaning (item 28, Appendix C)
 Tags, marking (item 30, Appendix C)

Materials/Parts

Detergent, GP (item 7, Appendix C)
 Packing, union adapter-to-manifold

Personnel Required

One

Equipment Condition

Pressure control valve removed
 (page 2-1200)

LOCATION	ITEM	ACTION	REMARKS
----------	------	--------	---------

REMOVAL

- | | | | |
|------------------------------------|--|--|--|
| 1. Valve (1) and union adapter (2) | Nut (3) | Using two 1 1/4-inch open-end wrenches, loosen. | |
| 2. Valve (1) | Union adapter (2) with assembled parts | a. Note relative position for proper placement during installation.
b. Using 1 1/4-inch open-end wrench, unscrew and take out.
c. Plug valve (1) (page 2-137). | |
| 3. Union adapter (2) | Packing (4) | a. Using pocket knife, take off.
b. Get rid of. | |
| 4. Elbow (5) | Hose (6) | a. Place drain pan underneath.
b. Using 1 1/16-inch and 1 1/4-inch open-end wrenches, unscrew and take out.
c. Tag (page 2-137). | |

PRESSURE CONTROL VALVE-TO-MANIFOLD OIL LINE (SERIAL NUMBERS 235786 THRU 235999 ONLY) - CONTINUED

LOCATION	ITEM	ACTION	REMARKS
5. Union adapter (7)	Elbow (5)	a. Note relative position for proper placement during installation. b. Using two 1 1/4-inch open-end wrenches, unscrew and take out.	
6. Manifold (8)	Union adapter (7) with assembled packing (9)	a. Using 1 1/4-inch open-end wrench, unscrew and take out. b. Plug manifold (8) (page 2-137).	
7. Union adapter (7)	Packing (9)	a. Using pocket knife, take off. b. Get rid of.	

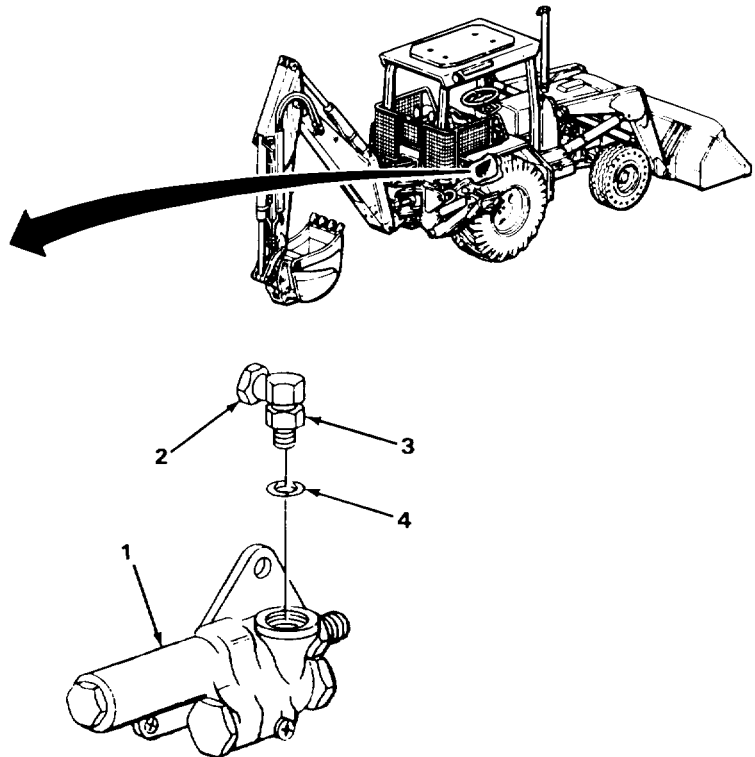
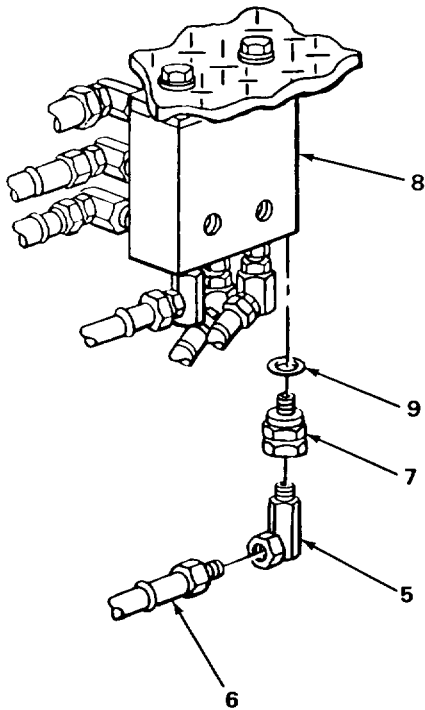

PRESSURE CONTROL VALVE.TO.MANIFOLD OIL LINE (SERIAL NUMBERS 235786 THRU 235999 ONLY) - CONTINUED

LOCATION	ITEM	ACTION	REMARKS
----------	------	--------	---------

CLEANING

NOTE

For more information on how to clean parts, go to **General Maintenance Instructions (page 2-137)**.

- | | | |
|----|----------|---|
| 8. | Hose (1) | <ul style="list-style-type: none"> a. Using clean rags dampened in solution of detergent and water, wipe clean. b. Rinse with clean water. c. Using clean, dry rags, wipe dry. |
|----|----------|---|

WARNING

Dry cleaning solvent P-D-680 is toxic and flammable. Wear protective goggles and gloves and use only in a well ventilated area. Avoid contact with skin, eyes, and clothes and don't breathe vapors. Do not use near open flame or excessive heat. The flashpoint is 100° F to 138° F (38° to 59° C). If you become dizzy while using cleaning solvent, get fresh air immediately and get medical aid. If contact with eyes is made, wash your eyes with water and get medical aid immediately.

- | | | |
|----|-----------------|--|
| 9. | All metal parts | <ul style="list-style-type: none"> a. Clean in dry cleaning solvent. b. Using clean, dry rags, wipe dry. |
|----|-----------------|--|

INSPECTION/REPLACEMENT

NOTE

For more information on how to inspect parts, go to **General Maintenance Instructions (page 2-137)**.

Replace defective parts as needed.

- | | | |
|-----|--------------------|--|
| 10. | Hose (1) | Look for cracks, breaks, tears and cuts. |
| 11. | All metal parts | Look for cracks and breaks. |
| 12. | All threaded parts | Look for damaged threads. |

INSTALLATION

- | | | |
|-----------------------|-----------------|--------------------|
| 13. Union adapter (2) | New packing (3) | Place in position. |
|-----------------------|-----------------|--------------------|

PRESSURE CONTROL VALVE-TO-MANIFOLD OIL LINE (SERIAL NUMBERS 235786 THRU 235999 ONLY) - CONTINUED

LOCATION	ITEM	ACTION	REMARKS
14. Manifold (4)	Union adapter (2) with assembled packing (3)	a. Unplug manifold (4). b. Screw in and tighten using 1 1/4-inch open-end wrench.	
15. Union adapter (2)	Elbow (5)	Screw in and tighten to same relative position noted during removal using two 1 1/4-inch open-end wrenches.	
16. Elbow (5)	Hose (1)	a. Take off tag. b. Screw in and tighten using 1 1/16-inch and 1 1/4-inch open-end wrenches.	
17. Union adapter (6)	Nut (7)	Screw on all the way.	
18.	New packing (8)	Place in position.	

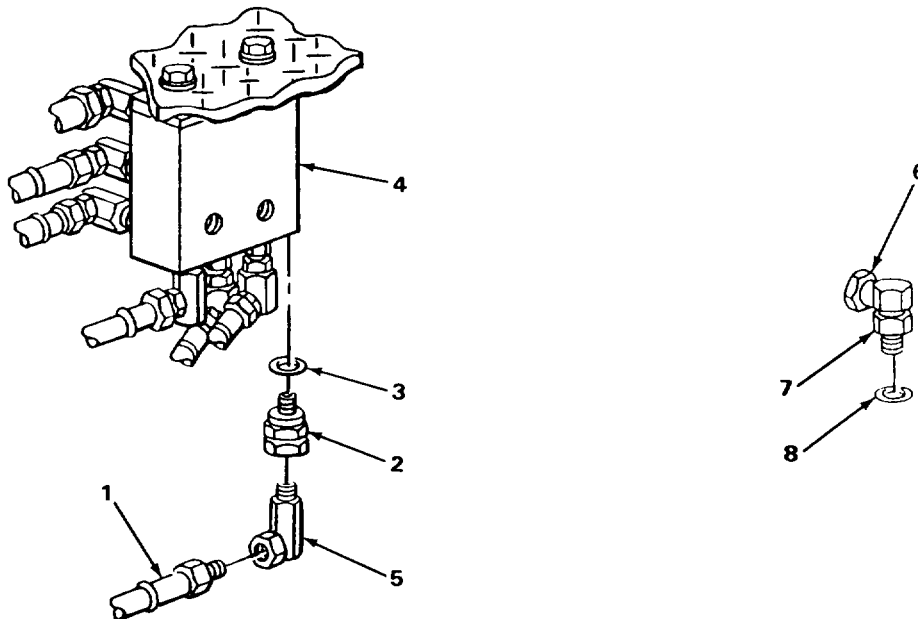

PRESSURE CONTROL VALVE-TO-MANIFOLD OIL LINE (SERIAL NUMBERS 235786 THRU 235999 ONLY) - CONTINUED

LOCATION	ITEM	ACTION REMARKS
INSTALLATION - CONTINUED		
19. Valve (1)	Union adapter (2) with assembled parts	Screw in and tighten to same relative position noted during removal using 1 1/4-inch open-end wrench.
20. Valve (1) and union adapter (2)	Nut (3)	Using two 1 1/4-inch open-end wrenches, tighten until seated against valve (1).
21. Loader backhoe	Pressure control valve	Install (page 2-1200).
22.	Transmission	Check fluid level and add proper amount and grade (TM 5-2420-222-10).
23.	Engine	Start and run at high idle (TM 5-2420-222-10).
24.	Pressure control valve-to-manifold oil line	<ul style="list-style-type: none"> a. Check for leaks. b. If leaking at any connection, tighten using 1 1/16-inch, 1 1/4-inch, and two 1 1/4-inch open-end wrenches. c. If leaking does not stop, shut down engine (TM 5-2420-222-10) and replace leaking connection packing, fitting, or hose as outlined in this task. d. If found leaking, repeat steps 22 thru 24.
25.	Engine	If still running, shut down (TM 5-2420-222-10).

PRESSURE CONTROL VALVE-TO-MANIFOLD OIL LINE (SERIAL NUMBERS 235786 THRU 235999 ONLY) - CONTINUED

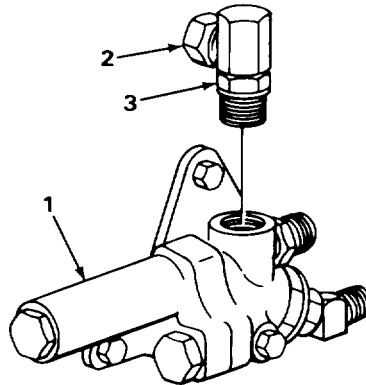

TASK ENDS HERE

PRESSURE CONTROL VALVE-TO-JAW DIRECT LINEAR VALVE OIL LINE (SERIAL NUMBERS 319995 THRU 342573 ONLY)

This task covers:

- | | |
|------------------------------|---|
| a. Removal (page 2-1406) | d. Inspection/Replacement (page 2-1408) |
| b. Disassembly (page 2-1407) | e. Assembly (page 2-1408) |
| c. Cleaning (page 2-1408) | f. Installation (page 2-1409) |

INITIAL SETUP

Tools

- Knife, pocket
- Pan, drain
- Vise, machinist's
- Wrench, open-end, 1 1/16-inch
- Wrench, open-end, 1 1/4-inch
(two required)

Materials/Parts

- Detergent, GP (item 7, Appendix C)
- Packing, adapter
- Packing, connector

Materials/Parts - Continued

- Rags, wiping (item 21, Appendix C)
- Solvent, dry cleaning (item 28, Appendix C)

Personnel Required

One

Equipment Condition

Pressure control valve removed
(page 2-1200)

TA243405

PRESSURE CONTROL VALVE-TO-JAW DIRECT LINEAR VALVE OIL LINE (SERIAL NUMBERS 319995 THRU 342573 ONLY) - CONTINUED

LOCATION	ITEM	ACTION REMARKS
REMOVAL		
1. Pressure control valve (1) and adapter (2)	Nut (3)	a. Place valve (1) in machinist's vise. b. Using two 1 1/4-inch open-end wrenches, loosen.
2. Pressure control valve (1)	Adapter (2) with assembled parts	a. Note relative position for proper placement during installation. b. Using 1 1/4-inch open-end wrench, unscrew and take out. c. Plug valve (1) (page 2-137). d. Take valve (1) out of machinist's vise.
3. Adapter (2)	Packing (4)	a. Using pocket knife, take off. b. Get rid of.
4. Tee (5)	Hose (6)	a. Place drain pan underneath. b. Using 1 1/16-inch and 1 1/4-inch open-end wrenches, unscrew and take off. c. Tag (page 2-137).
5. Elbow (7)	Hose (8)	a. Using 1 1/16-inch and 1 1/4-inch open-end wrenches, unscrew and take out. b. Cap (page 2-137). c. Tag (page 2-137).
6. Tee (9)	Hose (10)	a. Using 1 1/4-inch open-end wrench, unscrew and take off. b. Plug (page 2-137). c. Tag (page 2-137).
7. Connector (11)	Tee (9) with assembled parts	a. Note relative position for proper placement during installation. b. Using two 1 1/4-inch open-end wrenches, unscrew and take off.
8. Jaw direct linear valve (12)	Connector (11) with assembled packing (13)	a. Using 1 1/4-inch open-end wrench, unscrew and take out. b. Plug valve (12) (page 2-137). c. Get rid of drained fluid (page 2-137).
9. Connector (11)	Packing (13)	a. Using pocket knife, take off. b. Get rid of.

PRESSURE CONTROL VALVE-TO-JAW DIRECT LINEAR VALVE OIL LINE (SERIAL NUMBERS 31995 THRU 342573 ONLY) - CONTINUED

LOCATION	ITEM	ACTION	REMARKS
DISASSEMBLY			
10. Tee (5)	Pipe adapter (14) with assembled tee (9)	a. Place tee (5) in machinist's vise. b. Note relative position for proper placement during assembly. c. Using 1 1/4-inch open-end wrench, unscrew and take off.	
11.	Elbow (7)	a. Note relative position for proper placement during assembly. b. Using two 1 1/4-inch open-end wrenches, unscrew and take out. c. Take tee (5) out of machinist's vise.	
12. Tee (9)	Pipe adapter (14)	a. Place tee (9) in machinist's vise. b. Using 1 1/4-inch open-end wrench, unscrew and take off. c. Take tee (9) out of machinist's vise.	

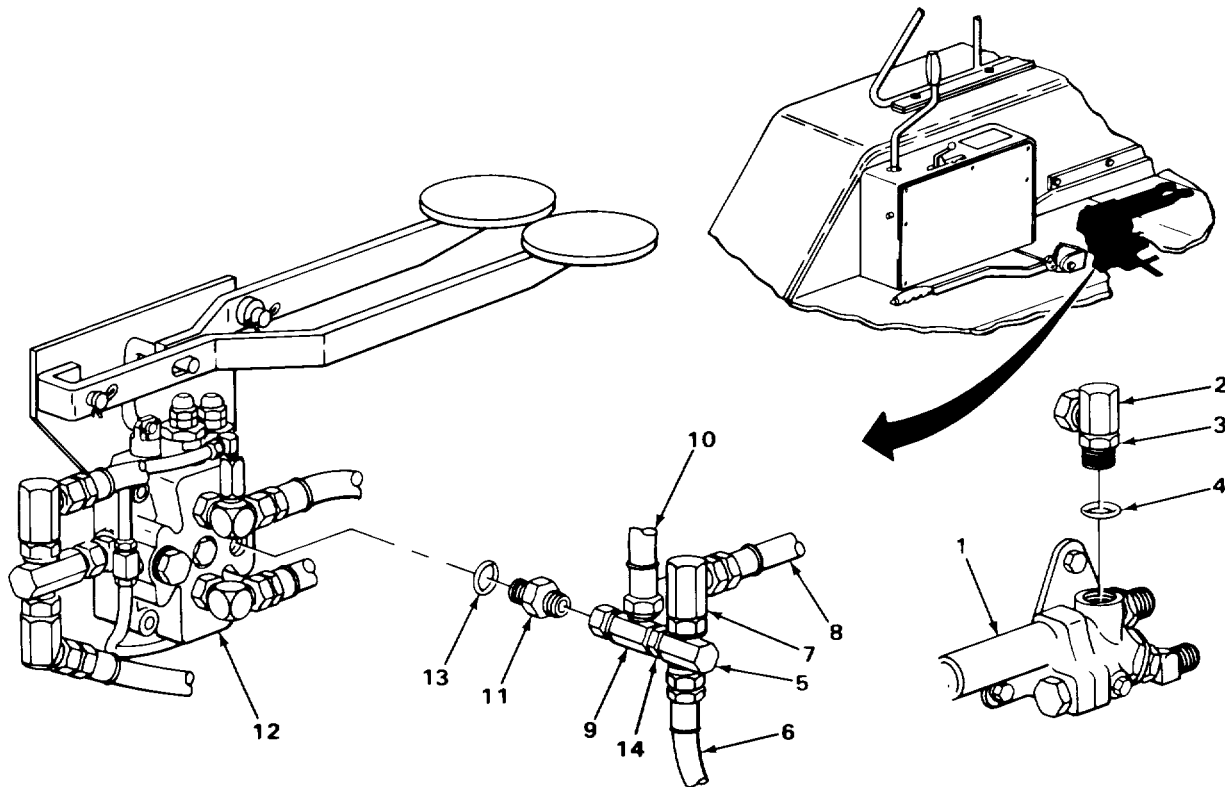

2-1407

PRESSURE CONTROL VALVE-TO-JAW DIRECT LINEAR VALVE OIL LINE (SERIAL NUMBERS 319995 THRU 342573 ONLY) - CONTINUED

LOCATION	ITEM	ACTION	REMARKS
----------	------	--------	---------

CLEANING

NOTE

For more information on how to clean parts, go to **General Maintenance Instructions (page 2-137)**.

- | | | | |
|-----|----------|---|--|
| 13. | Hose (1) | a. Using clean rags dampened in solution of detergent and water, wipe clean.
b. Rinse with clean water.
c. Using clean, dry rags, wipe dry. | |
|-----|----------|---|--|

WARNING

Dry cleaning solvent P-D-680 is toxic and flammable. Wear protective goggles and gloves and use only in a well ventilated area. Avoid contact with skin, eyes, and clothes and don't breathe vapors. Do not use near open flame or excessive heat. The flashpoint is 100°F to 138°F (38° to 59°C). If you become dizzy while using cleaning solvent, get fresh air immediately and get medical aid. If contact with eyes is made, wash your eyes with water and get medical aid immediately.

- | | | | |
|-----|-----------------|--|--|
| 14. | All metal parts | a. Clean in dry cleaning solvent.
b. Using clean, dry rags, wipe dry. | |
|-----|-----------------|--|--|

INSPECTION/REPLACEMENT

NOTE

For more information on how to inspect parts, go to **General Maintenance Instructions (page 2-137)**.

Replace defective parts as needed.

- | | | | |
|-----|--------------------|--|--|
| 15. | Hose (1) | Look for cracks, breaks, tears and cuts. | |
| 16. | All metal parts | Look for cracks and breaks. | |
| 17. | All threaded parts | Look for damaged threads. | |

ASSEMBLY

- | | | | |
|-----|---------|------------------|--|
| 18. | Tee (2) | Pipe adapter (3) | a. Place tee (2) in machinist's vise.
b. Screw on and tighten using 1 1/4-inch open-end wrench.
c. Take tee (2) out of machinist's vise. |
|-----|---------|------------------|--|

PRESSURE CONTROL VALVE-TO-JAW DIRECT LINEAR VALVE OIL LINE (SERIAL NUMBERS 31995 THRU 342573 ONLY) - CONTINUED

LOCATION	ITEM	ACTION	REMARKS
19. Tee (4)	Elbow (5)	a. Place tee (4) in machinist's vise. b. Screw in and tighten to same relative position noted during disassembly using two 1 1/4-inch open-end wrenches.	
20.	Pipe adapter (3) with assembled tee (2)	a. Screw in and tighten to same relative position noted during disassembly using 1 1/4-inch open-end wrench. b. Take tee (4) out of machinist's vise.	

INSTALLATION

21. Connector (6)	New packing (7)	Place in position.	
22. Jaw direct linear valve (8)	Connector (6) with assembled packing (7)	a. Unplug valve (8). b. Screw in and tighten using 1 1/4-inch open-end wrench.	

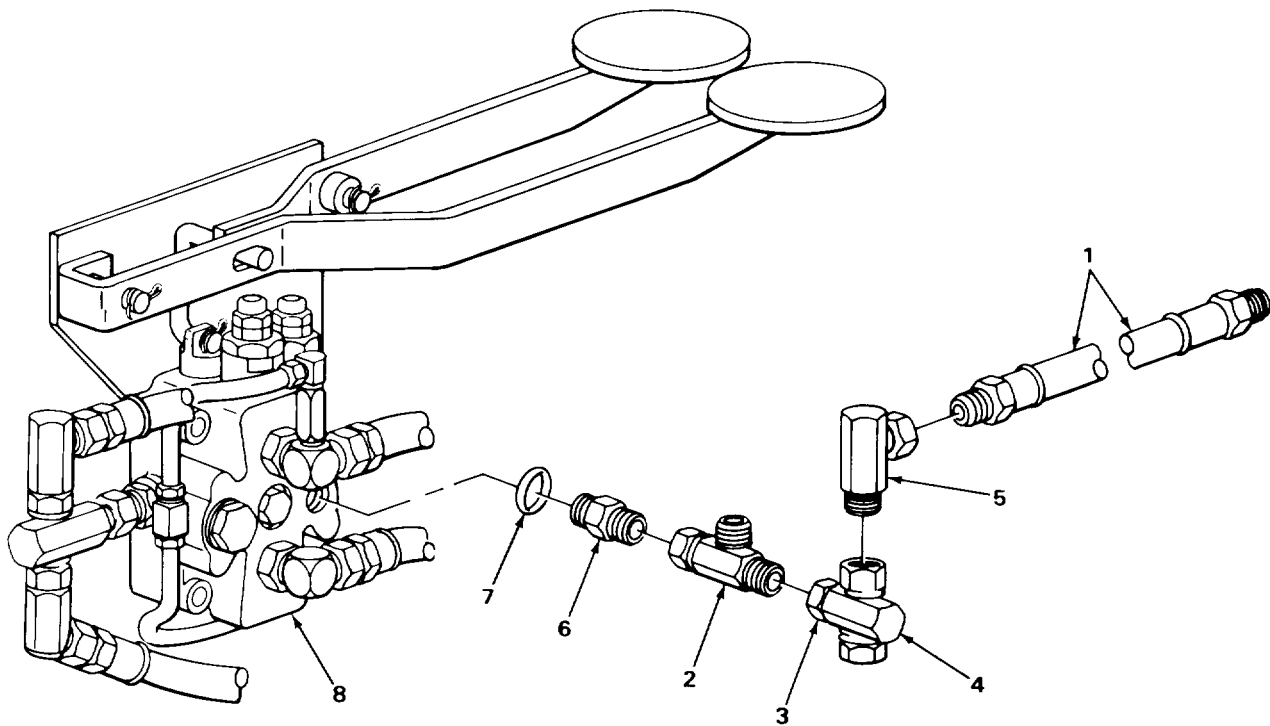

PRESSURE CONTROL VALVE-TO-JAW DIRECT LINEAR VALVE OIL LINE (SERIAL NUMBERS 319995 THRU 342573 ONLY) - CONTINUED

LOCATION	ITEM	ACTION REMARKS
INSTALLATION - CONTINUED		
23. Connector (1)	Tee (2) with assembled parts	Screw on and tighten to same relative position noted during removal using two 1 1/4-inch open-end wrenches.
24. Tee (2)	Hose (3)	a. Unplug. b. Take off tag. c. Screw on and tighten using 1 1/4-inch open-end wrench.
25. Elbow (4)	Hose (5)	a. Uncap. b. Take off tag. c. Screw in and tighten using 1 1/16-inch and 1 1/4-inch open-end wrenches.
26. Tee (6)	Hose (7)	a. Take off tag. b. Screw in and tighten using 1 1/16-inch and 1 1/4-inch open-end wrenches.
27. Adapter (8)	Nut (9)	Screw on all the way.
28.	New packing (10)	Place in position.
29. Pressure control valve (11)	Adapter (8) with assembled packing (10)	a. Unplug valve (11). b. Place valve (11) in machinist's vise. c. Screw in and tighten to same relative position noted during removal using 1 1/4-inch open-end wrench.
30. Pressure control valve (11) and adapter (8)	Nut (9)	a. Using two 1 1/4-inch open-end wrenches, tighten until seated against valve (11). b. Take valve (11) out of machinist's vise.
31. Loader backhoe	Pressure control valve	Install (page 2-1200).
32.	Transmission	Check fluid level and add proper amount and grade (TM 5-2420-222-10).
33.	Engine	Start and run at high idle (TM 5-2420-222-10).

PRESSURE CONTROL VALVE-TO-JAW DIRECT LINEAR VALVE OIL LINE (SERIAL NUMBERS 31995 THRU 342573 ONLY) - CONTINUED

LOCATION	ITEM	ACTION	REMARKS
34.	Pressure control valve-to-jaw direct linear valve oil line	a. Check for leaks. b. If leaking at any connection, tighten using 1 1/16-inch, 1 1/4-inch, and two 1 1/4-inch open-end wrenches. c. If leaking does not stop, shut down engine (TM 5-2420-222-10) and replace leaking connection packing, fitting, or hose as outlined in this task. d. If found leaking, repeat steps 32 thru 34.	
35.	Engine	If still running, shut down (TM 5-2420-222-10).	

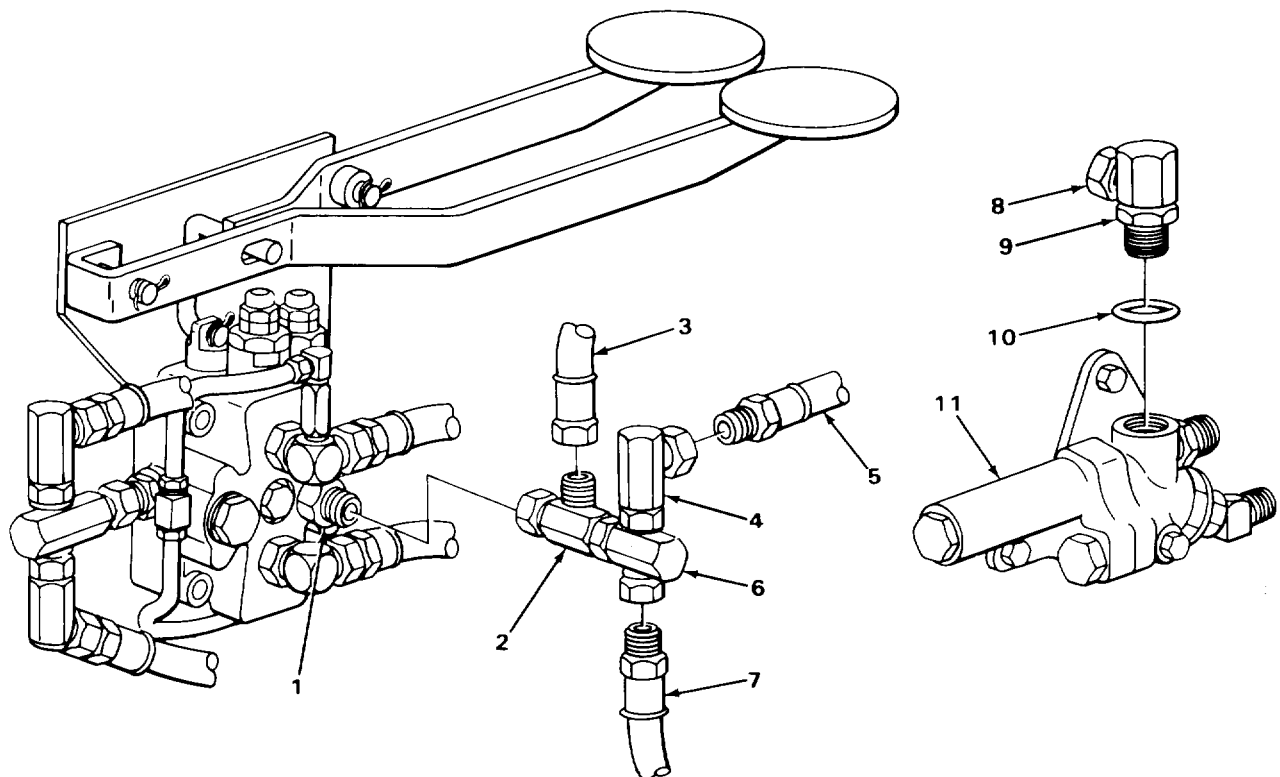

TASK ENDS HERE

2-1411

TA243408

BACKHOE CONTROL VALVE-TO-JAW DIRECT LINEAR VALVE OIL LINE (SERIAL NUMBERS 319995 THRU 342573 ONLY)

This task covers:

- a. Removal (page 2-1412)
- b. Disassembly (page 2-1414)
- c. Cleaning (page 2-1416)
- d. Inspection/Replacement (page 2-1416)
- e. Assembly (page 2-1417)
- f. Installation (page 2-1418)

INITIAL SETUP

Tools

- Handle, ratchet, 3/4-inch drive
- Knife, pocket
- Pan, drain
- Socket, 3/4-inch drive, 1 1/2-inch
- Vise, machinist's
- Wrench, box, 1 1/4-inch
- Wrench, open-end, 1 1/8-inch
- Wrench, open-end, 1 1/4-inch (two required)
- Wrench, open-end, 1 3/8-inch

Materials/Parts

- Detergent, GP (item 7, Appendix C)
- Packing, adapter
- Packing, connector
- Packing, union adapter

Materials/Parts - Continued

- Rags, wiping (item 21, Appendix C)
- Solvent, dry cleaning (item 28, Appendix C)
- Tags, marking (item 30, Appendix C)

Personnel Required

One

Equipment Condition

1. Hydraulic system pressure released (page 2-1191))
2. Right rear platform removed (page 2-1110)
3. Backhoe valve box cover removed (page 2-1157)

LOCATION	ITEM	ACTION	REMARKS
----------	------	--------	---------

REMOVAL

WARNING

Do not attempt to disconnect hydraulic lines and fittings while engine is running or before hydraulic system pressure has been released. When engine is running, hydraulic system is under pressure. Hydraulic system pressure should be 0 psi. (0 kPa) before lines are disconnected. A line or fitting disconnected under pressure will blow off with a lot of force and could cause serious injury to personnel.

Be careful when draining hot fluids. Wear gloves to protect your hands from hot parts and fluids or severe burns could result.

BACKHOE CONTROL VALVE-TO-JAW DIRECT LINEAR VALVE OIL LINE (SERIAL NUMBERS 319995 THRU 342573 ONLY) - CONTINUED

LOCATION	ITEM	ACTION REMARKS
1. Union adapter (1)	Hose (2)	a. Place drain pan underneath. b. Using 1 1/8-inch and 1 1/4-inch open-end wrenches, unscrew and take out. c. Cap (page 2-137). d. Tag (page 2-137).
2. Elbow (3)	Hose (4)	a. Using 1 11/8-inch and 1 1/4-inch open-end wrenches, unscrew and take out. b. Tag (page 2-137).
3. Connector (5)	Tee (6) with assembled parts	a. Note relative position for proper placement during installation. b. Using two 1 1/4-inch open-end wrenches, unscrew and take out.
4. Jaw direct linear valve (7)	Connector (5) with assembled packing (8)	a. Using 1 1/2-inch, 3/4-inch drive socket and ratchet handle, unscrew and take out. b. Plug valve (7) (page 2-137).

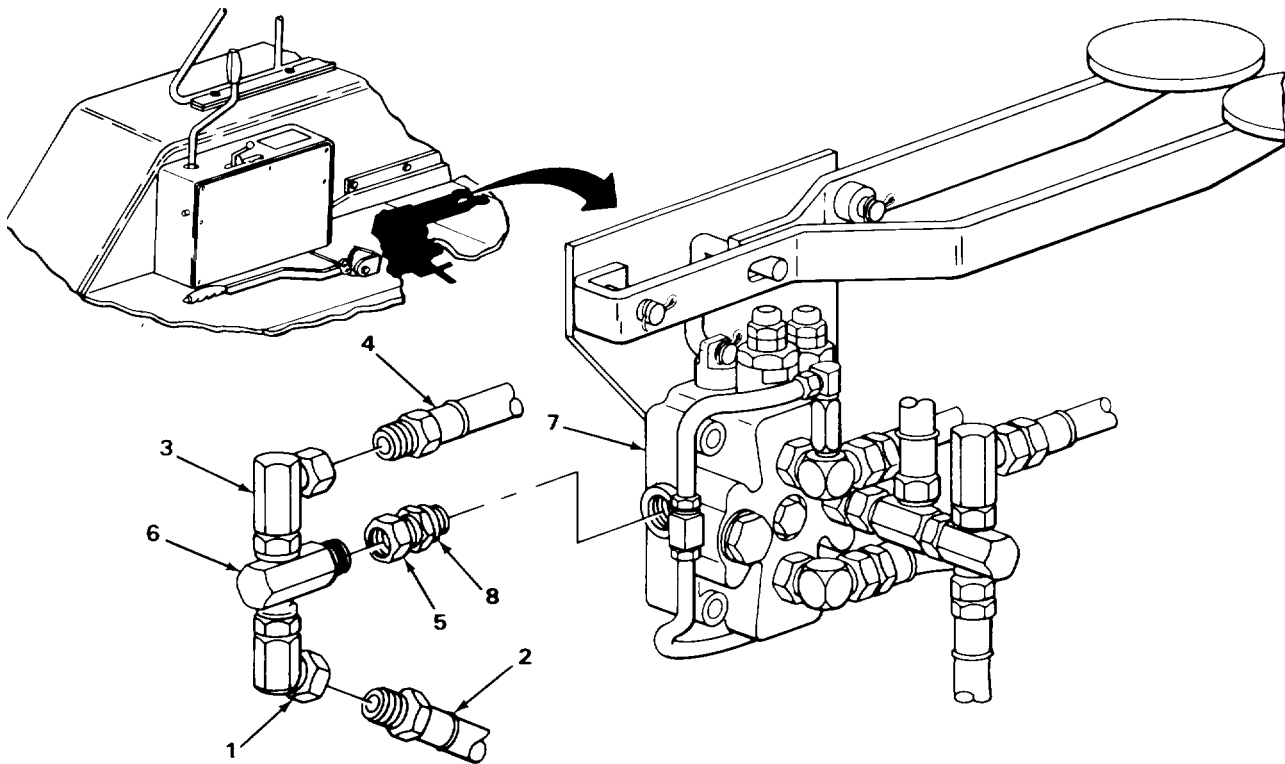

TA243409

BACKHOE CONTROL VALVE-TO-JAW DIRECT LINEAR VALVE OIL LINE (SERIAL NUMBERS 319995 THRU 342573 ONLY) - CONTINUED

LOCATION	ITEM	ACTION REMARKS
REMOVAL - CONTINUED		
5. Connector (1)	Packing (2)	a. Using pocket knife, take off. b. Get rid of.
6. Adapter (3)	Hose (4)	a. Place drain pan underneath. b. Using 1 1/8-inch and 1 1/4-inch open-end wrenches, unscrew and take out. c. Tag (page 2-137).
7. Adapter (5)	Hose (6)	a. Using 1 1/8-inch and 1 1/4-inch open-end wrenches, unscrew and take out. b. Cap (page 2-137). c. Tag (page 2-137).
8. Union adapter (7)	Adapter (3) with assembled parts	a. Note relative position for proper placement during installation. b. Using 1 1/4-inch and 1 3/8-inch open-end wrenches, unscrew and take out.
9. Backhoe control valve (8)	Union adapter (7) with assembled packing (9)	a. Using 1 1/4-inch box wrench, unscrew and take out. b. Plug valve (8) (page 2-137). c. Get rid of drained fluid (page 2-137).
10. Union adapter (7)	Packing (9)	a. Using pocket knife, take off. b. Get rid of.
DISASSEMBLY		
11. Adapter (3) and adapter (10)	Nut (11)	a. Place adapter (3) in machinist's vise. b. Using 1 1/8-inch and 1 1/4-inch open-end wrenches, loosen.
12. Adapter (3)	Adapter (3) with assembled parts	a. Note relative position for proper placement during assembly. b. Using 1 1/8-inch open-end wrench, unscrew and take out. c. Take adapter (3) out of machinist's vise.
13. Adapter (10)	Packing (12)	a. Using pocket knife, take off. b. Get rid of.

BACKHOE CONTROL VALVE-TO-JAW DIRECT LINEAR VALVE OIL LINE (SERIAL NUMBERS 319995 THRU 342573 ONLY) - CONTINUED

LOCATION	ITEM	ACTION REMARKS
14. Adapter (10)	Adapter (5)	a. Place adapter (10) in machinist's vise. b. Note relative position for proper placement during assembly. c. Using two 1 1/4-inch open-end wrenches, unscrew and take out. d. Take adapter (10) out of machinist's vise.
15. Union adapter (13)	Tee (14) with assembled elbow (15)	a. Place union adapter (13) in machinist's vise. b. Note relative position for proper placement during assembly. c. Using 1 1/4-inch open-end wrench, unscrew and take off. d. Take union adapter (13) out of machinist's vise.

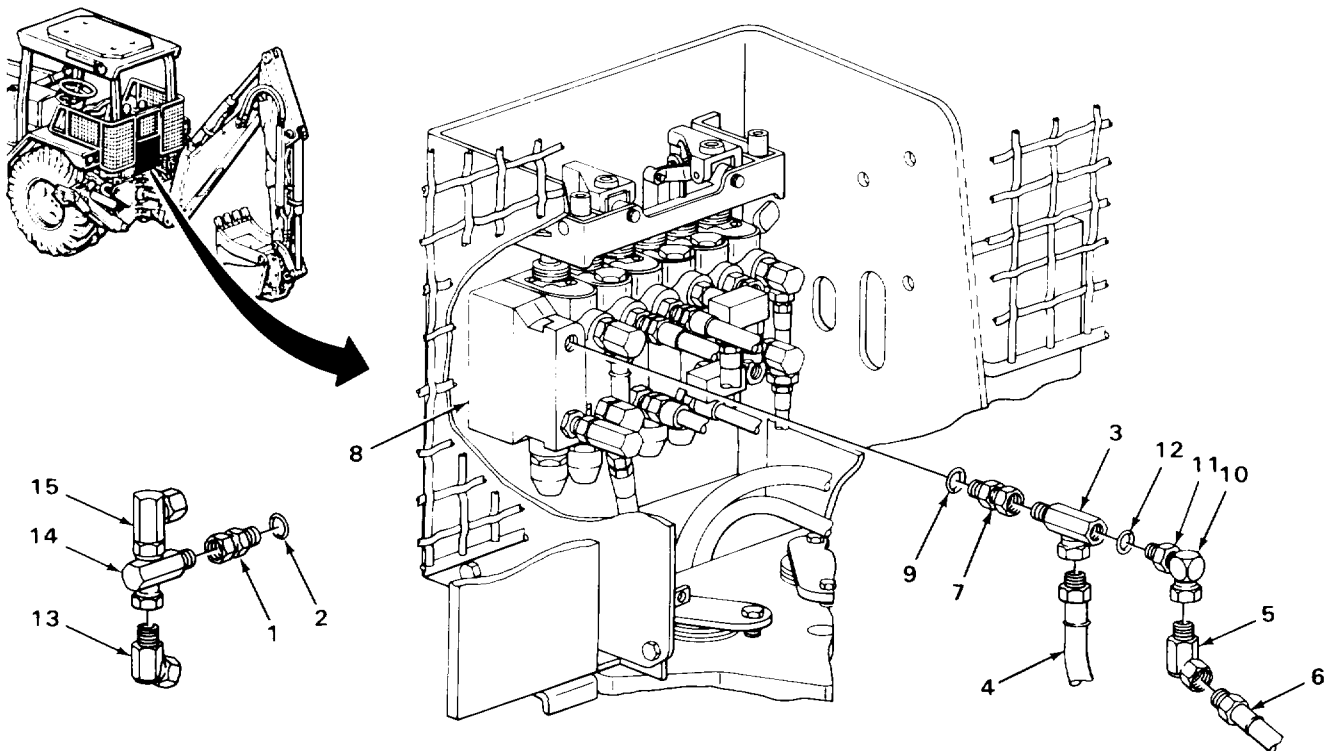

BACKHOE CONTROL VALVE-TO-JAW DIRECT LINEAR VALVE OIL LINE (SERIAL NUMBERS 319995 THRU 342573 ONLY) - CONTINUED

LOCATION	ITEM	ACTION REMARKS
DISASSEMBLY - CONTINUED		
16.	Elbow (1)	Tee (2)
		a. Place elbow (1) in machinist's vise. b. Note relative position for proper placement during assembly. c. Using 1 1/4-inch open-end wrench, unscrew and take out. d. Take elbow (1) out of machinist's vise.

CLEANING**NOTE**

For more information on how to clean parts, go to **General Maintenance Instructions (page 2-137)**.

17.	Hose (3)	a. Using clean rags dampened in solution of detergent and water, wipe clean. b. Rinse with clean water. c. Using clean, dry rags, wipe dry.
-----	----------	---

WARNING

Dry cleaning solvent P-D-680 is toxic and flammable. Wear protective goggles and gloves and use only in a well ventilated area. Avoid contact with skin, eyes, and clothes and don't breathe vapors. Do not use near open flame or excessive heat. The flashpoint is 100°F to 138°F (38° to 59°C). If you become dizzy while using cleaning solvent, get fresh air immediately and get medical aid. If contact with eyes is made, wash your eyes with water and get medical aid immediately.

18.	All metal parts	a. Clean in dry cleaning solvent. b. Using clean, dry rags, wipe dry.
-----	-----------------	--

INSPECTION/REPLACEMENT**NOTE**

For more information on how to inspect parts, go to **General Maintenance Instructions (page 2-137)**.

Replace defective parts as needed.

19.	Hose (3)	Look for cracks, breaks, cuts and tears.
20.	All metal parts	Look for cracks and breaks.

BACKHOE CONTROL VALVE-TO-JAW DIRECT LINEAR VALVE OIL LINE (SERIAL NUMBERS 319995 THRU 342573 ONLY) - CONTINUED

LOCATION	ITEM	ACTION REMARKS
21.	All threaded parts	Look for damaged threads.
ASSEMBLY		
22. Elbow (1)	Tee (2)	a. Place elbow (1) in machinist's vise. b. Screw on and tighten to same relative position noted during disassembly using 1 1/4-inch open-end wrench. c. Take elbow (1) out of machinist's vise.
23. Union adapter (4)	Tee (2) with assembled elbow (1)	a. Place union adapter (4) in machinist's vise. b. Screw in and tighten to same relative position noted during disassembly using 1 1/4-inch open-end wrench. c. Take union adapter (4) out of machinist's vise.
24. Adapter (5)	Adapter (6)	a. Place adapter (5) in machinist's vise. b. Screw in and tighten to same relative position noted during disassembly using two 1 1/4-inch open-end wrenches. c. Take adapter (5) out of machinist's vise.
25. Adapter (5)	Nut (7)	Screw on all the way.
26.	New packing (8)	Place in position.

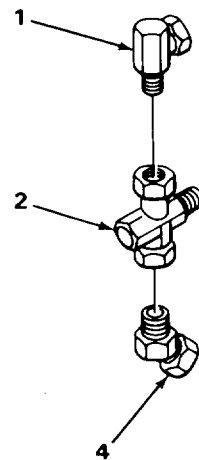
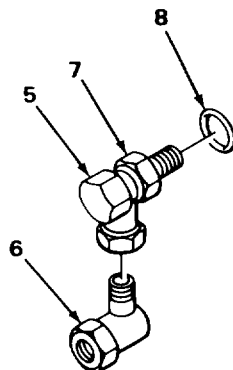
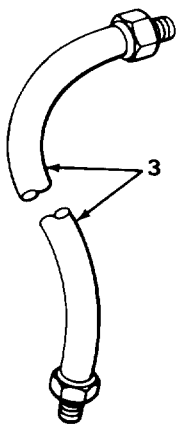

BACKHOE CONTROL VALVE-TO-JAW DIRECT LINEAR VALVE OIL LINE (SERIAL NUMBERS 319995 THRU 342573 ONLY) - CONTINUED

LOCATION	ITEM	ACTION	REMARKS
ASSEMBLY - CONTINUED			
27.	Adapter (1)	Adapter (2) with assembled parts	<ul style="list-style-type: none"> a. Place adapter (1) in machinist's vise. b. Screw in and tighten to same relative position noted during disassembly using 1 1/8-inch open-end wrench.
28.	Adapter (1) and adapter (2)	Nut (3)	<ul style="list-style-type: none"> a. Using 1 1/8-inch and 1 1/4-inch open-end wrenches, tighten until seated against adapter (1). b. Take adapter (1) out of machinist's vise.
INSTALLATION			
29.	Union adapter (4)	New packing (5)	Place in position.
30.	Backhoe control valve (6)	Union adapter(4) with assembled packing (5)	<ul style="list-style-type: none"> a. Unplug valve (6). b. Screw in and tighten using 1 1/4-inch box wrench.
31.	Union adapter (4)	Adapter (1) with assembled pans	Screw on and tighten to same relative position noted during removal using 1 1/4-inch and 1 3/8-inch open-end wrenches.
32.	Adapter (7)	Hose (8)	<ul style="list-style-type: none"> a. Uncap. b. Take off tag. c. Screw on and tighten using 1 1/8-inch and 1 1/4-inch open-end wrenches.
33.	Adapter(1)	Hose (9)	<ul style="list-style-type: none"> a. Takeoff tag. b. Screw in and tighten using 1 1/8-inch and 1 1/4 inch open-end wrenches.
34.	Connector (10)	New packing (11)	Place in position.
35.	Jaw direct linear valve (12)	Connector (10) with assembled packing (11)	<ul style="list-style-type: none"> a. Unplug valve (12). b. Screw in and tighten using 1 1/2-inch, 34-inch drive socket and ratchet handle.
36.	Connector (10)	Tee (13) with assembled parts	Screw in and tighten to same relative position noted during removal using two 1 1/4-inch open-end wrenches.

BACKHOE CONTROL VALVE-TO-JAW DIRECT LINEAR VALVE OIL LINE (SERIAL NUMBERS 319995 THRU 342573 ONLY) - CONTINUED

LOCATION	ITEM	ACTION	REMARKS
37. Elbow (14)	Hose (15)	a. Take off tag. b. Screw in and tighten using 1 1/8-inch and 1 1/4-inch open-end wrenches.	
38. Union adapter (16)	Hose (17)	a. Uncap. b. Take off tag. c. Screw in and tighten using 1 1/8-inch and 1 1/4-inch open-end wrenches.	

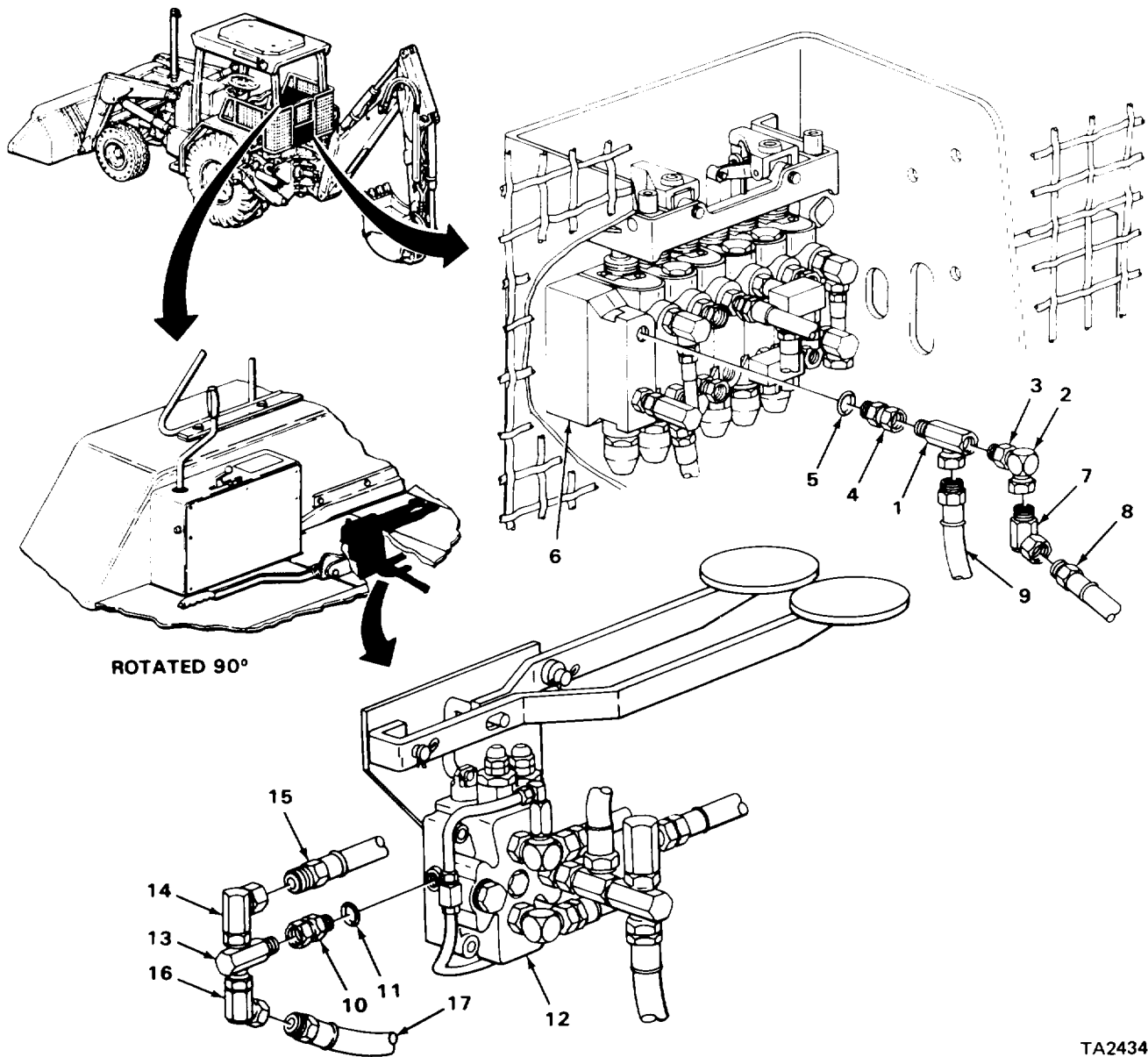

BACKHOE CONTROL VALVE-TO-JAW DIRECT LINEAR VALVE OIL LINE (SERIAL NUMBERS 319995 THRU 342573 ONLY) - CONTINUED

LOCATION	ITEM	ACTION	REMARKS
INSTALLATION - CONTINUED			
39.	Transmission		Check fluid level and add proper amount and grade (TM 5-2420-222-10).
40.	Engine		Start and run at high idle (TM 5-2420-222-10).
41.	Backhoe control valve-to-jaw direct linear valve oil line	<ol style="list-style-type: none"> a. Check for leaks. b. If leaking at any connection, tighten using 1 1/8-inch, two 1 1/4-inch, and 1 3/8-inch open-end wrenches. c. If leaking does not stop, shut down engine (TM 5-2420-222-10) and replace leaking connection packing, fitting, or hose as outlined in this task. d. If found leaking, repeat steps 39 thru 41. 	
42.	Engine		If still running, shut down (TM 5-2420-222-10).

NOTE

FOLLOW-ON MAINTENANCE:

1. Install backhoe valve box cover (page 2-1157).
2. Install right rear platform (page 2-1110).

TASK ENDS HERE

JAW DIRECT LINEAR VALVE-TO-HYDRAULIC IMPACTOR VALVE OIL LINE (SERIAL NUMBERS 31995 THRU 342573 ONLY)

This task covers:

- | | |
|------------------------------|---|
| a. Removal (page 2-1422) | d. Inspection/Replacement (page 2-1425) |
| b. Disassembly (page 2-1424) | e. Assembly (page 2-1425) |
| c. Cleaning (page 2-1424) | f. Installation (page 2-1426) |
-

INITIAL SETUP

Tools

Knife, pocket
 Pan, drain
 Vise, machinist's
 Wrench, open-end, 1 1/16-inch
 Wrench, open-end, 1 1/8-inch
 Wrench, open-end, 1 1/4-inch
 (two required)

Materials/Parts

Detergent, GP (item 7, Appendix C)
 Packing, connector

Materials/Parts - Continued

Rags, wiping (item 21, Appendix C)
 Solvent, dry cleaning (item 28, Appendix C)
 Tags, marking (item 30, Appendix C)

Personnel Required

One

Equipment Condition

Hydraulic system pressure released
 (page 2-1191)

2-1421

JAW DIRECT LINEAR VALVE-TO-HYDRAULIC IMPACTOR VALVE OIL LINE (SERIAL NUMBERS 319995 THRU 342573 ONLY) - CONTINUED

LOCATION	ITEM	ACTION	REMARKS
REMOVAL			
<u>WARNING</u>			
<p>Do not attempt to disconnect hydraulic lines and fittings while engine is running or before hydraulic system pressure has been released. When engine is running, hydraulic system is under pressure. Hydraulic system pressure should be 0 psi (0 kPa) before lines are disconnected. A line or fitting disconnected under pressure will blow off with a lot of force and could cause serious injury to personnel.</p>			
<p>Be careful when draining hot fluids. Wear gloves to protect your hands from hot parts and fluids or severe burns could result.</p>			
1. Elbow (1)	Hose (2)	a. Place drain pan underneath. b. Using 1 1/16-inch and 1 1/4-inch open-end wrenches, unscrew and take out. c. Cap (page 2-137). d. Tag (page 2-137).	
2. Tee (3)	Hose (4)	a. Using 1 1/16-inch and 1 1/4-inch open-end wrenches, unscrew and take out. b. Tag (page 2-137).	
3. Tee (5)	Hose (6)	a. Using 1 1/16-inch and 1 1/4-inch open-end wrenches, unscrew and take out. b. Cap (page 2-137). c. Tag (page 2-137).	
4. Connector (7)	Tee (3) with assembled parts	a. Note relative position for proper placement during installation. b. Using two 1 1/4-inch open-end wrenches, unscrew and take off.	
5. Jaw direct linear valve (8)	Connector (7) with assembled packing (9)	a. Using 1 1/4-inch open-end wrench, unscrew and take out. b. Plug valve (8) (page 2-137).	
6. Connector (7)	Packing (9)	a. Using pocket knife, take off. b. Get rid of.	
7. Elbow and packing assembly (10)	Hose (4)	a. Place drain pan underneath. b. Using 1 11/4-inch open-end wrench, unscrew and take off. c. Tag (page 2-137).	

JAW DIRECT LINEAR VALVE-TO-HYDRAULIC IMPACTOR VALVE OIL LINE (SERIAL NUMBERS 31995 THRU 342573 ONLY) - CONTINUED

LOCATION	ITEM	ACTION	REMARKS
8. Impactor valve(11) and elbow and packing assembly (10)	Nut (12)	a. Using 1 1/8-inch and 1 1/4-inch open-end wrenches, loosen.	
9. Impactor valve(11)	Elbow and packing assembly (10)	a. Note relative position for proper placement during installation. b. Using 1 1/8-inch open-end wrench, unscrew and take out. c. Plug valve (11) (page 2-137). d. Get rid of drained fluid (page 2-137).	

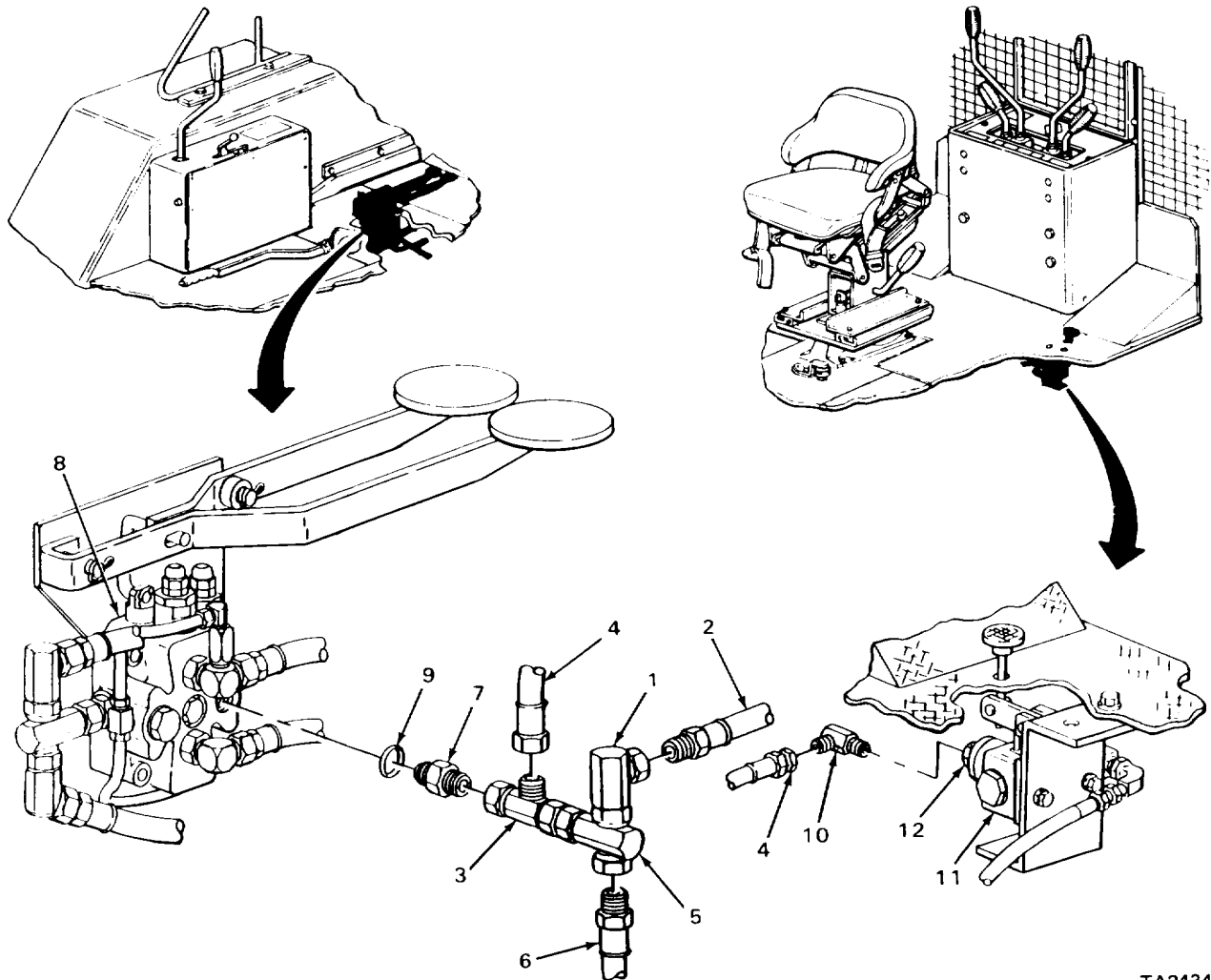

TA243413

JAW DIRECT LINEAR VALVE-TO-HYDRAULIC IMPACTOR VALVE OIL LINE (SERIAL NUMBERS 31995 THRU 342573 ONLY) - CONTINUED

LOCATION	ITEM	ACTION	REMARKS
DISASSEMBLY			
10. Tee (1)	Pipe adapter (2) with assembled tee (3)	a. Place tee (1) in machinist's vise. b. Note relative position for proper placement during assembly. c. Using 1 1/4-inch open-end wrench, unscrew and take off.	
11.	Elbow (4)	a. Note relative position for proper placement during assembly. b. Using two 1 1/4-inch open-end wrenches, unscrew and take out. c. Take tee (1) out of machinist's vise.	
12. Tee (3)	Pipe adapter (2)	a. Place tee (3) in machinist's vise. b. Using 1 1/4-inch open-end wrench, unscrew and take off. c. Take tee (3) out of machinist's vise.	

CLEANING**NOTE**

For more information on how to clean parts, go to General Maintenance Instructions (page 2-137).

13.	Hose (5)	a. Using clean rags dampened in solution of detergent and water, wipe clean. b. Rinse with clean water. c. Using clean, dry rags, wipe dry.	
-----	----------	--	--

WARNING

Drycleaning solvent P-D-680 is toxic and flammable. Wear protective goggles and gloves and use only in a well ventilated area. Avoid contact with skin, eyes, and clothes and don't breathe vapors. Do not use near open flame or excessive heat. The flashpoint is 100°F to 138°F (38° to 59°C). If you become dizzy while using cleaning solvent, get fresh air immediately and get medical aid. If contact with eyes is made, wash your eyes with water and get medical aid immediately.

14.	All metal parts	a. Clean in drycleaning solvent. b. Using clean, dry rags, wipe dry.	
-----	-----------------	---	--

JAW DIRECT LINEAR VALVE-TO-HYDRAULIC IMPACTOR VALVE OIL LINE (SERIAL NUMBERS 31995 THRU 342573 ONLY) - CONTINUED

LOCATION	ITEM	ACTION	REMARKS
----------	------	--------	---------

INSPECTION/REPLACEMENT

NOTE

For more information on how to inspect parts, go to General Maintenance Instructions (page 2-137).

Replace defective parts as needed.

- | | | |
|-----|--------------------------------|---|
| 15. | Hose (5) | Look for cracks, breaks, cuts, and tears. |
| 16. | All metal parts | Look for cracks and breaks. |
| 17. | Elbow and packing assembly (6) | Look for damaged packing.
If packing is damaged, replace complete assembly. |
| 18. | All threaded parts | Look for damaged threads. |

ASSEMBLY

- | | | |
|-------------|------------------|---|
| 19. Tee (3) | Pipe adapter (2) | <ol style="list-style-type: none"> Place tee (3) in machinist's vise. Screw on and tighten using 1 1/4-inch open-end wrench. Take tee (3) out of machinist's vise. |
| 20. Tee (1) | Elbow (4) | <ol style="list-style-type: none"> Place tee (1) in machinist's vise. Screw in and tighten to same relative position noted during disassembly using two 1 1/4-inch open-end wrenches. |

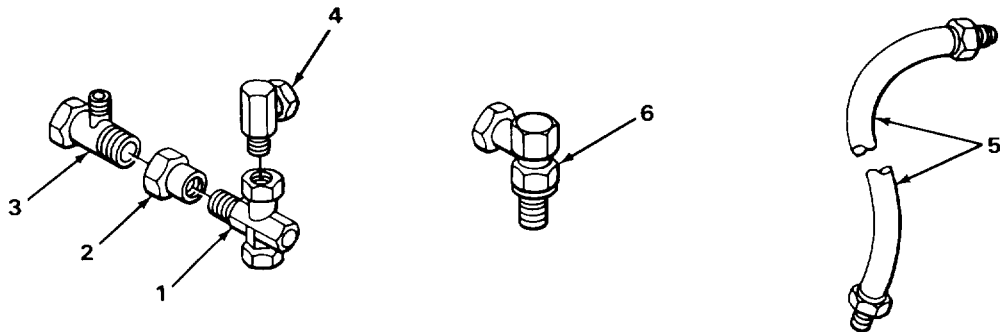

TA243414

JAW DIRECT LINEAR VALVE-TO-HYDRAULIC IMPACTOR VALVE OIL LINE (SERIAL NUMBERS 31995 THRU 342573 ONLY) - CONTINUED

LOCATION	ITEM	ACTION REMARKS
ASSEMBLY - CONTINUED		
21. Tee (1)	Pipe adapter (2) with assembled tee (3)	a. Screw on and tighten to same relative position noted during disassembly using 1 1/4-inch open-end wrench. b. Take tee (1) out of machinist's vise.
INSTALLATION		
22. Impactor valve (4)	Elbow and packing assembly (5)	a. Unplug valve (4). b. Screw in and tighten to same relative position noted during removal using 1 1/8-inch open-end wrench.
23. Impactor valve (4) and elbow and packing assembly (5)	Nut (6)	Using 1 1/8-inch and 1 1/4-inch open-end wrenches, tighten until seated against valve (4).
24. Elbow and packing assembly (5)	Hose (7)	a. Take off tag. b. Screw on and tighten using 1 1/4-inch open-end wrench.
25. Connector (8)	New packing (9)	Place in position.
26. Jaw direct linear valve (10)	Connector (8) with assembled packing (9)	a. Unplug valve(10). b. Screw in and tighten using 1 1/4-inch open-end wrench.
27. Connector (8)	Tee (3) with assembled parts	Screw on and tighten to same relative position noted during removal using two 1 1/4-inch open-end wrenches.
28. Tee(1)	Hose (11)	a. Uncap. b. Take off tag. c. Screw in and tighten using 1 1/16-inch and 1 1/4-inch open-end wrenches.
29. Tee (3)	Hose (7)	a. Take off tag. b. Screw in and tighten using 1 1/16-inch and 1 1/4-inch open-end wrenches.

JAW DIRECT LINEAR VALVE-TO-HYDRAULIC IMPACTOR VALVE OIL LINE (SERIAL NUMBERS 31995 THRU 342573 ONLY) - CONTINUED

LOCATION	ITEM	ACTION	REMARKS
30. Elbow (12)	Hose (13)	a. Uncap. b. Take off tag. c. Screw in and tighten using 1 1/8-inch and 1 1/4-inch open-end wrenches.	
31. Loader backhoe	Transmission	Check fluid level and add proper amount and grade (TM 5-2420-222-10).	

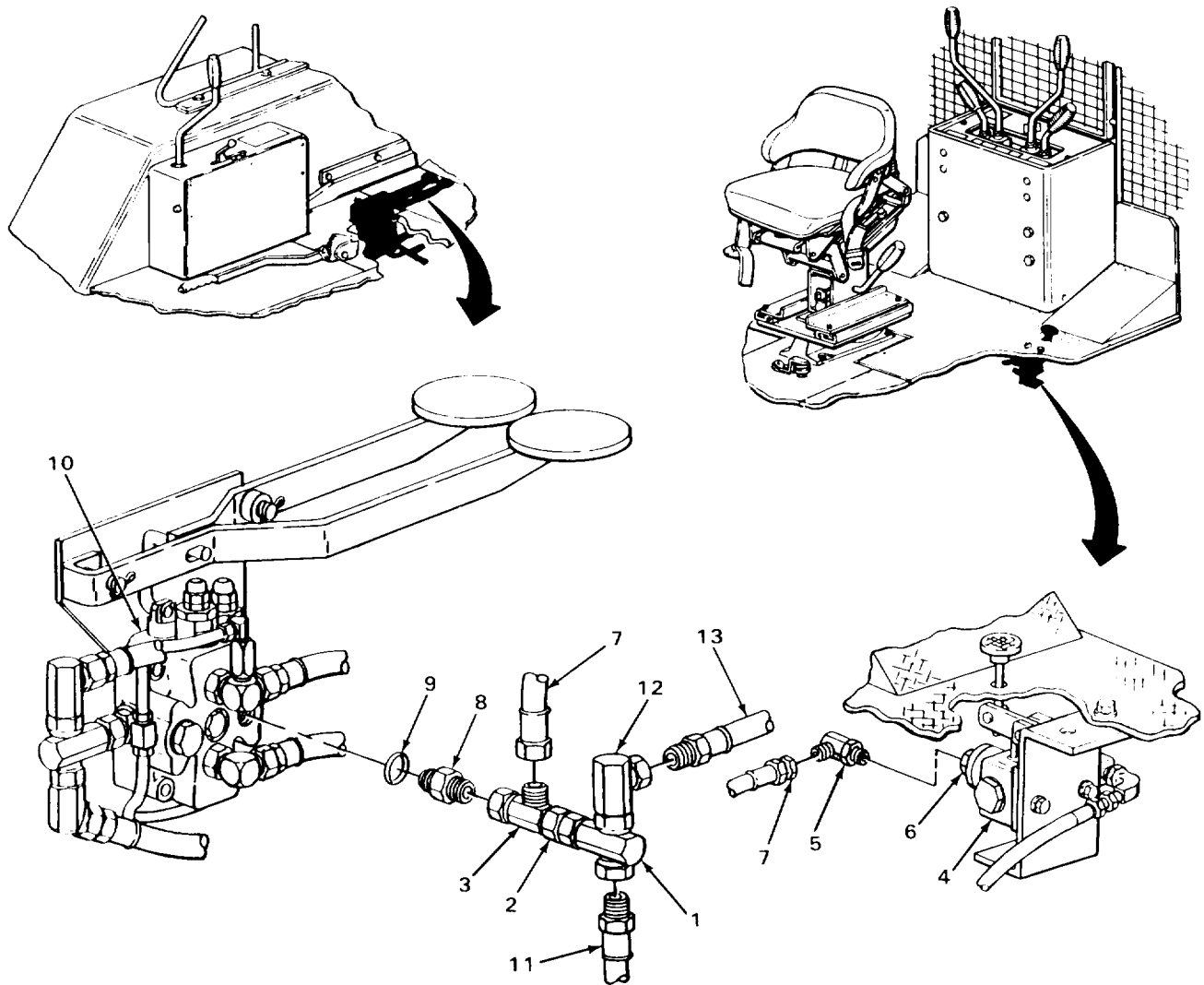

TA243415

JAW DIRECT LINEAR VALVE-TO-HYDRAULIC IMPACTOR VALVE OIL LINE (SERIAL NUMBERS 31995 THRU 342573 ONLY) - CONTINUED

LOCATION	ITEM	ACTION REMARKS
INSTALLATION - CONTINUED		
32.	Engine	Start and run at high idle (TM 5-2420-222-10).
33.	Jaw direct linear valve-to-impactor valve oil line	<ul style="list-style-type: none"> a. Check for leaks. b. If leaking at any connection, tighten using 1 1/16-inch, 1 1/8-inch, and two 1 1/4-inch open-end wrenches. c. If leaking does not stop, shut down engine (TM 5-2420-222-10) and replace leaking connection packing, fitting, or hose as outlined in this task. d. If found leaking, repeat steps 31 thru 33.
34.	Engine	If still running, shut down (TM 5-2420-222-10).

TASK ENDS HERE

BACKHOE CONTROL VALVE-TO-MANIFOLD OIL LINES (SERIAL NUMBERS 235786 THRU 235999 ONLY)

This task covers:

- a. Removal (page 2-1429)
- b. Cleaning (page 2-1431)
- c. Inspection/Replacement (page 2-1432)
- d. Installation (page 2-1432)

INITIAL SETUP:

Tools

- Knife, pocket
- Pan, drain
- Wrench, box, 1 1/4-inch
- Wrench, open-end, 1 1/16-inch
- Wrench, open-end, 1 1/4-inch (two required)
- Wrench, open-end, 1 3/8-inch

Materials/Parts

- Detergent, GP (item 7, Appendix C)
- Packing, elbow (page 2-1191)
- Packing, union adapter

Materials/Parts - Continued

- Rags, wiping (item 21, Appendix C)
- Solvent, drycleaning (item 28, Appendix C)
- Tags, marking (item 30, Appendix C)

Personnel Required

One

Equipment Condition

1. Hydraulic system pressure released
2. Backhoe valve box cover removed (page 2-1157)

LOCATION	ITEM	ACTION	REMARKS
----------	------	--------	---------

REMOVAL

NOTE

Both backhoe control valve-to-manifold block oil lines are maintained the same way. Return oil hose must be disconnected at backhoe control valve and capped in order to remove pressure oil line.

BACKHOE CONTROL VALVE-TO-MANIFOLD OIL LINES (SERIAL NUMBERS 235786 THRU 235999 ONLY) - CONTINUED

LOCATION	ITEM	ACTION	REMARKS
REMOVAL - CONTINUED			
<u>WARNING</u>			
<p>Do not attempt to disconnect hydraulic lines and fittings while engine is running or before hydraulic system pressure has been released. When engine is running, hydraulic system is under pressure. Hydraulic system pressure should be 0 psi (0 kPa) before lines are disconnected. A line or fitting disconnected under pressure will blow off with a lot of force and could cause serious injury to personnel.</p>			
<p>Be careful when draining hot fluids. Wear gloves to protect your hands from hot parts and fluids or severe burns could result.</p>			
1. Adapter (1)	Hose (2)	a. Place drain pan underneath. b. Using 1 118-inch and 1 1/4-inch open-end wrenches, unscrew and take out. c. Tag (page 2-137).	
2. Union adapter (3)	Adapter (1)	a. Note relative position for proper placement during installation. b. Using 1 114-inch and 1 3/8-inch open-end wrenches, unscrew and take out.	
3. Valve (4)	Union adapter (3) with assembled packing (5)	a. Using 1 1/4-inch box wrench, unscrew and take out. b. Plug valve (4) (page 2-137).	
4. Union adapter (3)	Packing (5)	a. Using pocket knife, take off. b. Get rid of.	
5. Elbow (6)	Hose (2)	a. Place drain pan underneath. b. Using 1 1/8-inch and 1 1/4-inch open-end wrenches, unscrew and take out. c. Tag (page 2-137).	
6. Elbow (6) and manifold (7)	Nut (8)	Using two 1 1/4-inch open-end wrenches, loosen.	
7. Manifold (7)	Elbow (6) with assembled parts	a. Note relative position for proper placement during installation. b. Using 1 1/4-inch open-end wrench, unscrew and take out. c. Plug manifold (7) (page 2-137). d. Get rid of drained fluid (page 2-137).	

BACKHOE CONTROL VALVE-TO-MANIFOLD OIL LINES (SERIAL NUMBERS 235786 THRU 235999 ONLY) - CONTINUED

LOCATION	ITEM	ACTION	REMARKS
8. Elbow (6)	Packing (9)	a. Using pocket knife, take off. b. Get rid of.	

CLEANING

NOTE

For more information on how to clean parts, go to **General Maintenance Instructions**(page 2-137).

9.	Hose (1)	a. Using clean rags dampened in solution of detergent and water, wipe clean. b. Rinse with clean water. c. Using clean, dry rags, wipe dry.
----	----------	---

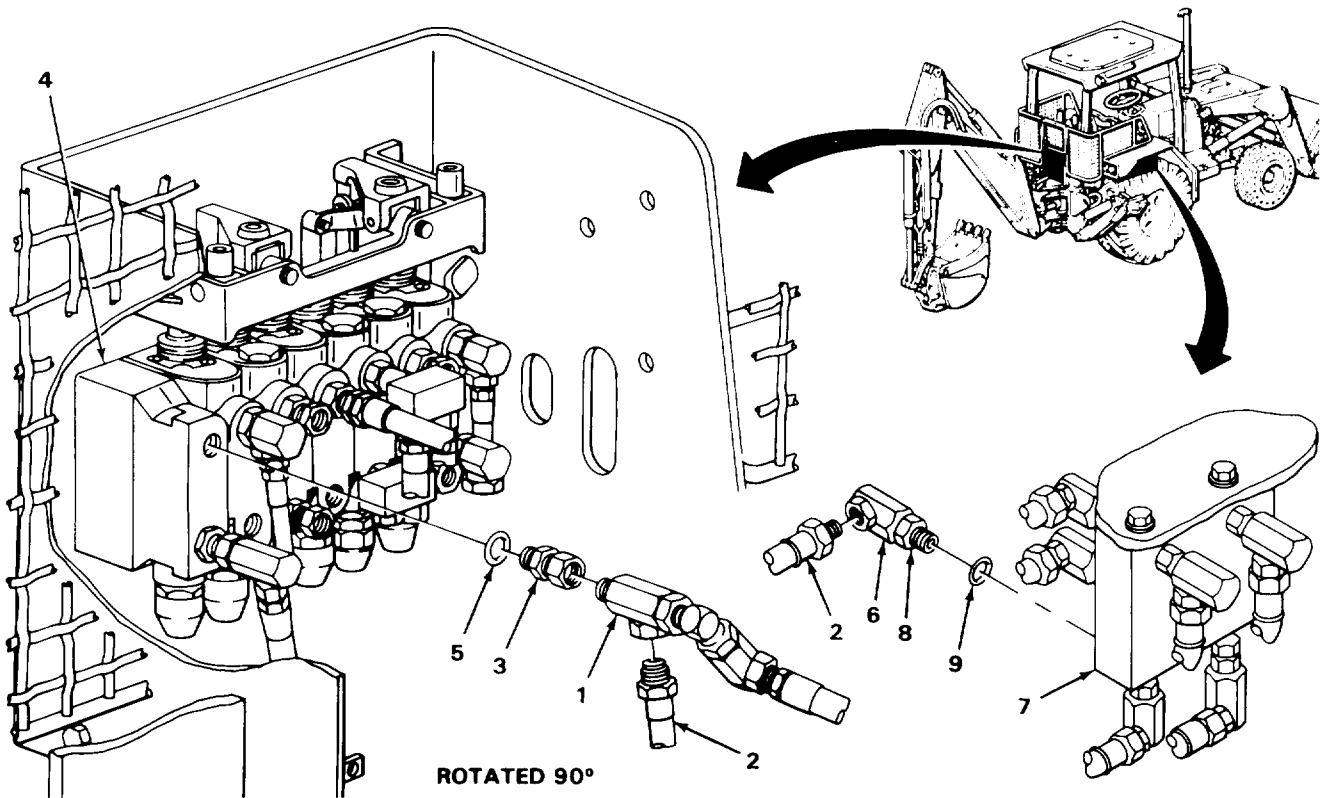

TA243416

BACKHOE CONTROL VALVE-TO-MANIFOLD OIL LINES (SERIAL NUMBERS 235786 THRU 235999 ONLY) - CONTINUED

LOCATION	ITEM	ACTION	REMARKS
----------	------	--------	---------

CLEANING - CONTINUED
WARNING

Drycleaning solvent P-D-680 is toxic and flammable. Wear protective goggles and gloves and use only in a well ventilated area. Avoid contact with skin, eyes, and clothes and don't breathe vapors. Do not use near open flame or excessive heat. The flashpoint is 100°F to 138°F (38° to 59°C). If you become dizzy while using cleaning solvent, get fresh air immediately and get medical aid. If contact with eyes is made, wash your eyes with water and get medical aid immediately.

- | | | | |
|-----|-----------------|----------------------------------|-------------------------------------|
| 10. | All metal parts | a. Clean in drycleaning solvent. | b. Using clean, dry rags, wipe dry. |
|-----|-----------------|----------------------------------|-------------------------------------|

INSPECTION/REPLACEMENT
NOTE

For more information on how to inspect parts, go to **General Maintenance Instructions (page 2-137)**.

Replace defective parts as needed.

- | | | | |
|-----|--------------------|---|--|
| 11. | Hose (1) | Look for cracks, breaks, cuts, and tears. | |
| 12. | All metal parts | Look for cracks and breaks. | |
| 13. | All threaded parts | Look for damaged threads. | |

INSTALLATION

- | | | | |
|--------------------------------|--------------------------------|--|--|
| 14. Elbow (2) | Nut (3) | Screw on all the way. | |
| 15. | New packing (4) | Place in position. | |
| 16. Manifold (5) | Elbow (2) with assembled parts | a. Unplug manifold (5).
b. Screw in and tighten to position noted during removal using 1 11/4-inch open-end wrench. | |
| 17. Elbow (2) and manifold (5) | Nut (3) | Using two 1 1/4-inch open-end wrenches, tighten until seated against manifold (5). | |

BACKHOE CONTROL VALVE-TO-MANIFOLD OIL LINES (SERIAL NUMBERS 235786 THRU 235999 ONLY) - CONTINUED

LOCATION	ITEM	ACTION REMARKS
18. Elbow (2)	Hose (1)	a. Take off tag. b. Screw in and tighten using 1 1/8-inch and 1 1/4-inch open-end wrenches.
19. Union adapter (6)	New packing (7)	Place in position.
20. Valve (8)	Union adapter (6) with assembled packing (7)	a. Unplug valve (8). b. Screw in and tighten using 1 1/4-inch box wrench.
21. Union adapter (6)	Adapter (9)	Screw in and tighten to same relative position noted during removal using 1 1/4-inch and 1 3/8-inch open-end wrenches.

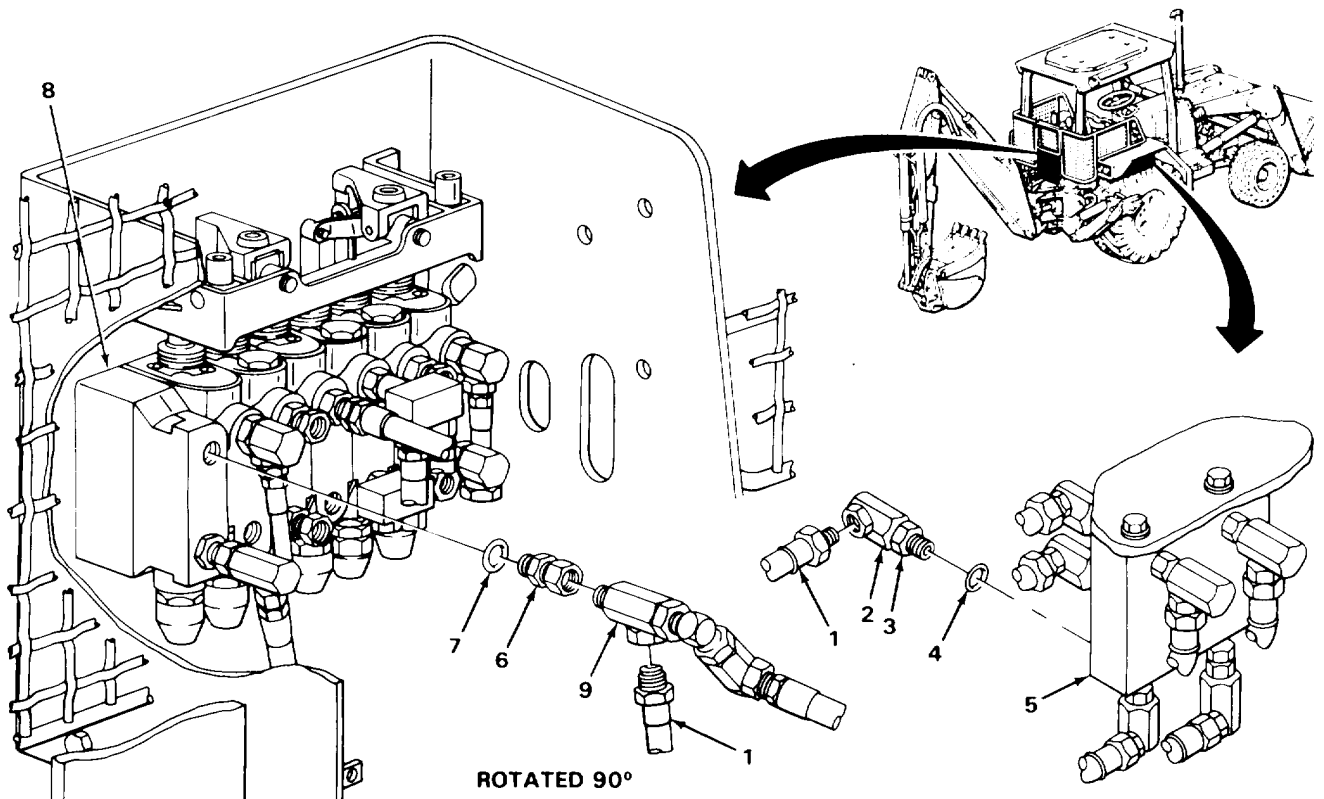

TA243417

BACKHOE CONTROL VALVE-TO-MANIFOLD OIL LINES (SERIAL NUMBERS 235786 THRU 235999 ONLY) - CONTINUED

LOCATION	ITEM	ACTION REMARKS
INSTALLATION - CONTINUED		
22. Adapter (1)	Hose (2)	a. Take off tag. b. Screw in and tighten using 1 1/8-inch and 1 1/4-inch open-end wrenches.
23. Loader backhoe	Transmission	Check fluid level and add proper amount and grade (TM 5-2420-222-10).
24.	Engine	Start and run at high idle (TM 5-2420-222-10).
25.	Backhoe control valve-to-manifold oil lines	a. Check for leaks. b. If leaking at any connection, tighten using 1 1/8-inch, 1 1/4-inch, and 1 3/8-inch open-end wrenches. c. If leaking does not stop, shut down engine (TM 5-2420-222-10) and replace leaking connection packing, fitting, or hose as outlined in this task. d. If found leaking, repeat steps 23 thru 25.
26.	Engine	If still running, shut down (TM 5-2420-222-10).

BACKHOE CONTROL VALVE-TO-MANIFOLD OIL LINES (SERIAL NUMBERS 235786 THRU 235999 ONLY) - CONTINUED

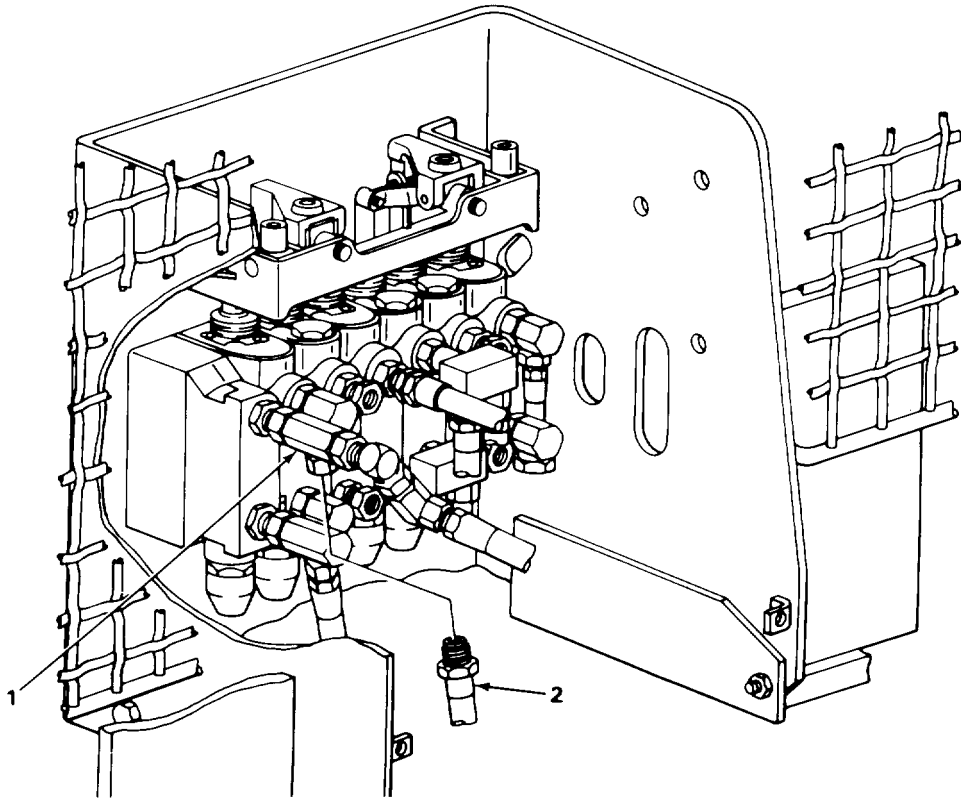

NOTE

FOLLOW-ON MAINTENANCE: Install backhoe valve box cover (page 2-1157).

TASK ENDS HERE

JAW DIRECT LINEAR VALVE-TO-BACKHOE CONTROL VALVE OIL LINE (SERIAL NUMBERS 319995 THRU 342573 ONLY)

This task covers:

- | | |
|------------------------------|---|
| a. Removal (page 2-1436) | d. Inspection/Replacement (page 2-1440) |
| b. Disassembly (page 2-1438) | e. Assembly (page 2-1440) |
| c. Cleaning (page 2-1439) | f. Installation (page 2-1441) |

INITIAL SETUP:

Tools

- Handle, ratchet, 3/4-inch drive
- Knife, pocket
- Pan, drain
- Socket, 3/4-inch drive, 1 1/4-inch
- Vise, machinist's
- Wrench, open-end, 1 1/16-inch
- Wrench, open-end, 1 1/8-inch
- Wrench, open-end, 1 1/4-inch (two required)
- Wrench, open-end, 1 3/8-inch

Materials/Parts (page 2-1191)

- Detergent, GP (item 7, Appendix C)
- Packing, connector
- Packing, union adapter

Materials/Parts - Continued

- Rags, wiping (item 21, Appendix C)
- Solvent, drycleaning (item 28, Appendix C)
- Tags, marking (item 30, Appendix C)

Personnel Required

One

Equipment Condition

1. Hydraulic system pressure released
2. Backhoe valve box cover removed (page 2-1157)

LOCATION	ITEM	ACTION	REMARKS
----------	------	--------	---------

REMOVAL

WARNING

Do not attempt to disconnect hydraulic lines and fittings while engine is running or before hydraulic system pressure has been released. When engine is running, hydraulic system is under pressure. Hydraulic system pressure should be 0 psi (0 kPa) before lines are disconnected. A line or fitting disconnected under pressure will blow off with a lot of force and could cause serious injury to personnel.

Be careful when draining hot fluids. Wear gloves to protect your hands from hot parts and fluids or severe burns could result.

- | | | |
|--------------|----------|--|
| 1. Elbow (1) | Hose (2) | <ol style="list-style-type: none"> a. Place drain pan underneath. b. Using 1 1/16-inch and 1 1/4-inch open-end wrenches, unscrew and take out. c. Tag (page 2-137). |
|--------------|----------|--|

JAW DIRECT LINEAR VALVE-TO-BACKHOE CONTROL VALVE OIL LINE (SERIAL NUMBERS 319995 THRU 342573 ONLY) - CONTINUED

LOCATION	ITEM	ACTION	REMARKS
2. Tee (3)	Hose (4)	a. Using 1 1/4-inch open-end wrench, unscrew and take out. b. Cap (page 2-137). c. Tag (page 2-137).	
3. Tee (5)	Hose (6)	a. Using 1 1/16-inch and 1 11/4-inch open-end wrenches, unscrew and take out. b. Cap (page 2-137). c. Tag (page 2-137).	
4. Connector (7)	Tee (3) with assembled parts	Using two 1 1/4-inch open-end wrenches, unscrew and take off.	
5. Jaw direct linear valve (8)	Connector (7) with assembled packing (9)	a. Using 1 1/4-inch open-end wrench, unscrew and take out. b. Plug valve (8) (page 2-137).	
6. Connector (7)	Packing (9)	a. Using pocket knife, take off. b. Get rid of.	

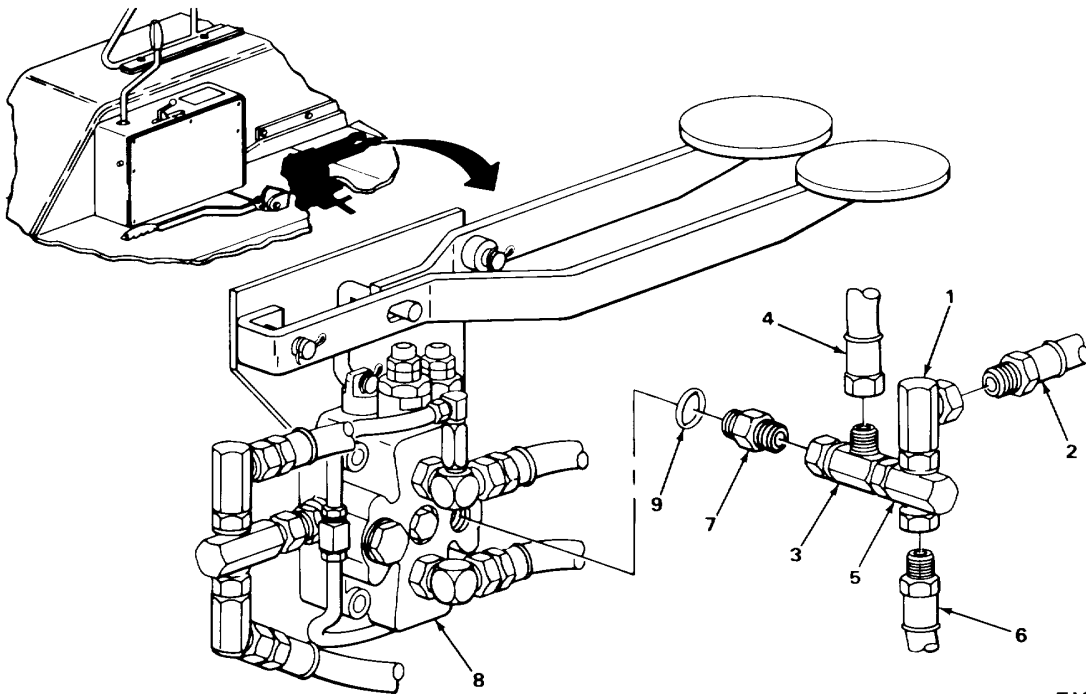

TA243419

JAW DIRECT LINEAR VALVE-TO-BACKHOE CONTROL VALVE OIL LINE (SERIAL NUMBERS 319995 THRU 342573 ONLY) - CONTINUED

LOCATION	ITEM	ACTION REMARKS
REMOVAL - CONTINUED --		
7. Adapter (1)	Hose (2)	a. Place drain pan underneath. b. Using 1 1/8-inch and 1 1/4-inch open-end wrenches, unscrew and take out. c. Cap (page 2-137). d. Tag (page 2-137).
8. Union adapter (3)	Adapter (1) with assembled parts	a. Using 1 1/4-inch and 1 3/8-inch open-end wrenches, unscrew and take out. b. Tag (page 2-137). c. Cap (page 2-137). d. Plug union adapter (3) (page 2-137).
9. Adapter (4)	Hose (5)	a. Using 1 1/16-inch and 1 1/4-inch open-end wrenches, unscrew and take out. b. Tag (page 2-137).
10. Union adapter (6)	Adapter (4)	a. Note relative position for proper placement during installation. b. Using 1 1/4-inch and 1 3/8-inch open-end wrenches, unscrew and take out.
11. Backhoe control valve (7)	Union adapter (6) with assembled packing (8)	a. Using 1 1/4-inch, 3/4-inch drive socket and ratchet handle, unscrew and take out. b. Plug valve (7) (page 2-137). c. Get rid of drained fluid (page 2-137).
12. Union adapter (6)	Packing (8)	a. Using pocket knife, take off. b. Get rid of.
DISASSEMBLY		
13. Tee (9)	Pipe adapter (10) with assembled tee (11)	a. Place tee (9) in machinist's vise. b. Note relative position for proper placement during assembly. c. Using 1 1/4-inch open-end wrench, unscrew and take off.
14.	Elbow (12)	a. Note relative position for proper placement during assembly. b. Using two 1 1/4-inch open-end wrenches, unscrew and take out. c. Take tee (9) out of machinist's vise.

JAW DIRECT LINEAR VALVE-TO-BACKHOE CONTROL VALVE OIL LINE (SERIAL NUMBERS 319995 THRU 342573 ONLY) - CONTINUED

LOCATION	ITEM	ACTION	REMARKS
15. Tee (11)	Pipe adapter (10)	a. Place tee (11) in machinist's vise. b. Using 1 1/4-inch open-end wrench, unscrew and take off. c. Take tee (11) out of machinist's vise.	

CLEANING

NOTE

For more information on how to clean parts, go to **General Maintenance Instructions**(page 2-137).

16.	Hose (3)	a. Using clean rags dampened in solution of detergent and water, wipe clean. b. Rinse with clean water. c. Using clean, dry rags, wipe dry.
-----	----------	---

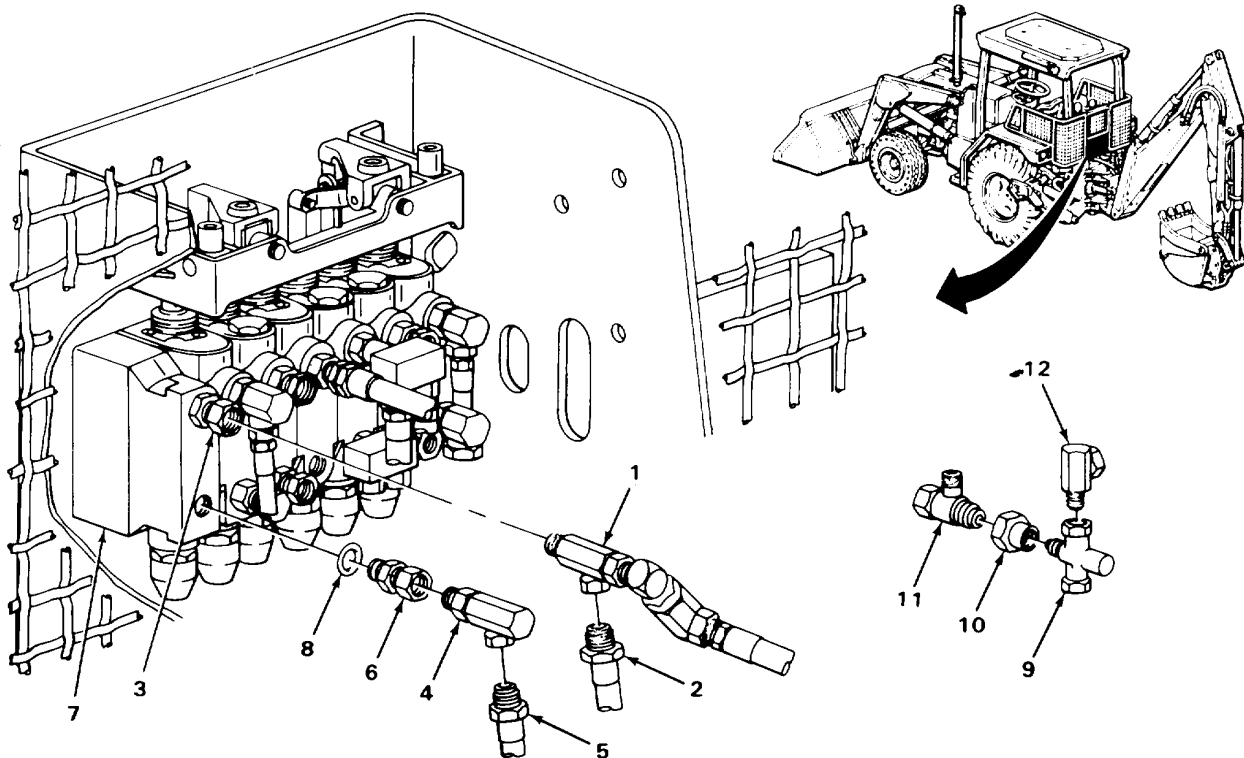

TA243420

JAW DIRECT LINEAR VALVE-TO-BACKHOE CONTROL VALVE OIL LINE (SERIAL NUMBERS 319995 THRU 342573 ONLY) - CONTINUED

LOCATION	ITEM	ACTION	REMARKS
----------	------	--------	---------

CLEANING - CONTINUED

WARNING

Drycleaning solvent P-D-680 is toxic and flammable. Wear protective goggles and gloves and use only in a well ventilated area. Avoid contact with skin, eyes, and clothes and don't breathe vapors. Do not use near open flame or excessive heat. The flashpoint is 100°F to 138°F (38° to 59°C). If you become dizzy while using cleaning solvent, get fresh air immediately and get medical aid. If contact with eyes is made, wash your eyes with water and get medical aid immediately.

- | | | | |
|-----|-----------------|---|--|
| 17. | All metal parts | <ul style="list-style-type: none"> a. Clean in drycleaning solvent. b. Using clean, dry rags, wipe dry. | |
|-----|-----------------|---|--|

INSPECTION/REPLACEMENT

NOTE

For more information on how to inspect parts, go to General Maintenance Instructions (page 2-137).

Replace defective parts as needed.

- | | | | |
|-----|--------------------|--|--|
| 18. | Hose (1) | Look for cracks, breaks, cuts and tears. | |
| 19. | All metal parts | Look for cracks and breaks. | |
| 20. | All threaded parts | Look for damaged threads. | |

ASSEMBLY

- | | | | |
|-------------|---|---|--|
| 21. Tee (2) | Pipe adapter (3) | <ul style="list-style-type: none"> a. Place tee (2) in machinist's vise. b. Screw on and tighten using 1 1/4-inch open-end wrench. c. Take tee (2) out of machinist's vise. | |
| 22. Tee (4) | Elbow (5) | <ul style="list-style-type: none"> a. Place tee (4) in machinist's vise. b. Screw in and tighten to same relative position noted during disassembly using two 1 1/4-inch open-end wrenches. | |
| 23. | Pipe adapter (3) with assembled tee (2) | <ul style="list-style-type: none"> a. Screw on and tighten to same relative position noted during disassembly using 1 1/4-inch open-end wrench. b. Take tee (4) out of machinist's vise. | |

JAW DIRECT LINEAR VALVE-TO-BACKHOE CONTROL VALVE OIL LINE (SERIAL NUMBERS 319995 THRU 342573 ONLY) - CONTINUED

LOCATION	ITEM	ACTION	REMARKS
INSTALLATION			
24. Union adapter (6)	New packing (7)	Place in position.	
25. Backhoe control valve (8)	Union adapter (6) with assembled packing (7)	a. Unplug valve (8). b. Screw in and tighten using 1 1/4-inch, 3/4-inch drive socket and ratchet handle.	
26. Union adapter (6)	Adapter (1)	Screw on and tighten to same relative position noted during removal using 1 1/4-inch and 1 3/8-inch open-end wrenches.	
27. Adapter(9)	Hose (1)	a. Takeoff tag. b. Screw in and tighten using 1 1/16-inch and 1 1/4-inch open-end wrenches.	

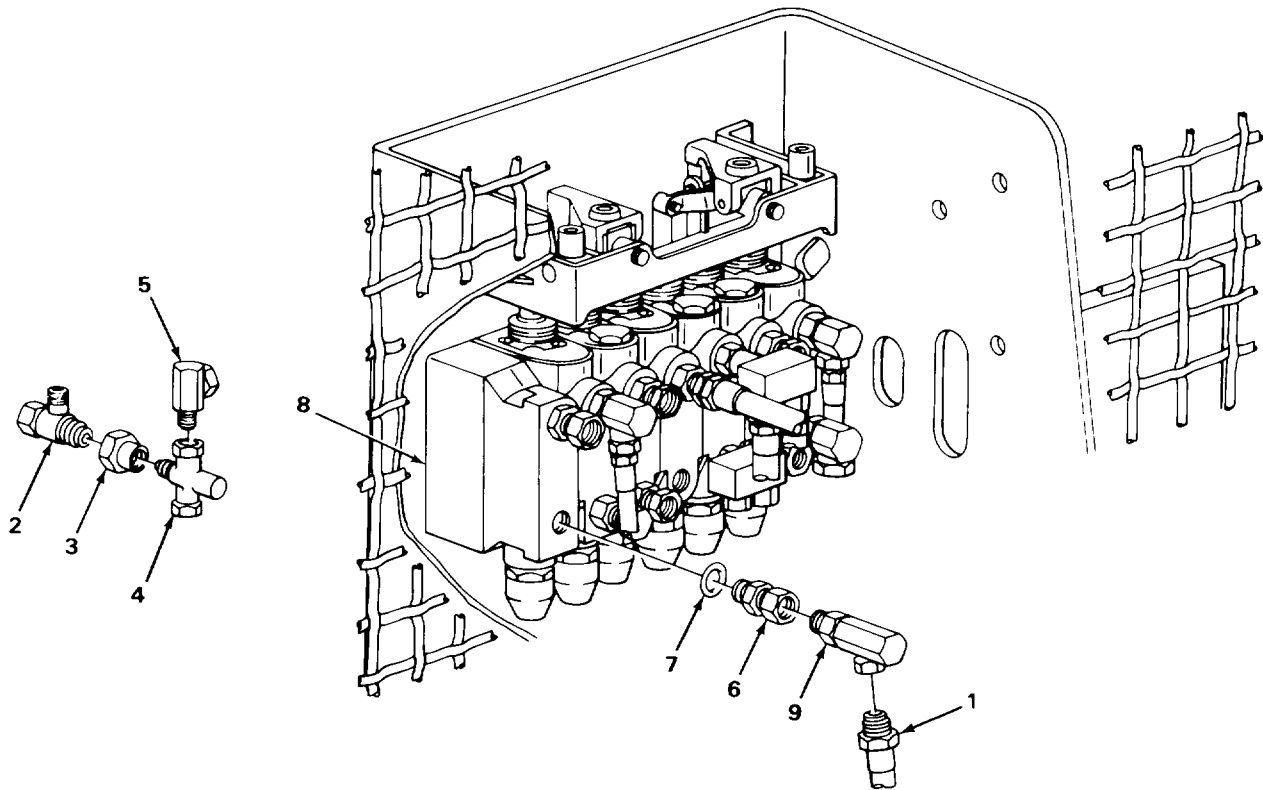

TA243422

JAW DIRECT LINEAR VALVE-TO-BACKHOE CONTROL VALVE OIL LINE (SERIAL NUMBERS 319995 THRU 342573 ONLY) - CONTINUED

LOCATION	ITEM	ACTION REMARKS
INSTALLATION - CONTINUED		
28. Union adapter (1)	Adapter (2) with assembled parts	a. Unplug union adapter (1). b. Uncap. c. Take off tag. d. Screw in and tighten using 1 1/4-inch and 1 3/8-inch open-end wrenches.
29. Adapter (2)	Hose (3)	a. Uncap. b. Take off tag. c. Screw in and tighten using 1 1/8-inch and 1 1/4-inch open-end wrenches.
30. Connector (4)	New packing (5)	Place in position.
31. Jaw direct linear valve (6)	Connector (4) with assembled parts	a. Unplug valve (6). b. Screw in and tighten using 1 1/4-inch, open-end wrench.
32. Connector (4)	Tee (7) with assembled parts	Screw on and tighten using two 1 1/4- inch open-end wrenches.
33. Tee (7)	Hose (8)	a. Unplug. b. Take off tag. c. Screw in and tighten using 1 1/4-inch open-end wrench.
34. Tee (9)	Hose (10)	a. Unplug. b. Take off tag. c. Screw in and tighten using 1 1/16-inch and 1 11/4-inch open-end wrenches.
35. Elbow (11)	Hose (12)	a. Take off tag. b. Screw in and tighten using 1 1/16-inch and 1 1/4-inch open-end wrenches.
36. Loader backhoe	Transmission	Check fluid level and add proper amount and grade (TM 5-2420-222-10).
37.	Engine	Start and run at high idle (TM 5-2420-222-10).

JAW DIRECT LINEAR VALVE-TO-BACKHOE CONTROL VALVE OIL LINE (SERIAL NUMBERS 319995 THRU 342573 ONLY) - CONTINUED

LOCATION	ITEM	ACTION	REMARKS
----------	------	--------	---------

38.

Jaw direct linear valve-to-backhoe control valve oil line

- a. Check for leaks.
- b. If leaking at any connection, tighten using 1 1/16-inch, 1 1/8-inch, two 1 1/4-inch and 1 3/8-inch open-end wrenches.
- c. If leaking does not stop, shut down engine (TM 5-2420-222-10) and replace leaking connection packing, fitting, or hose as outlined in this task.
- d. If found leaking, repeat steps 36 thru 38.

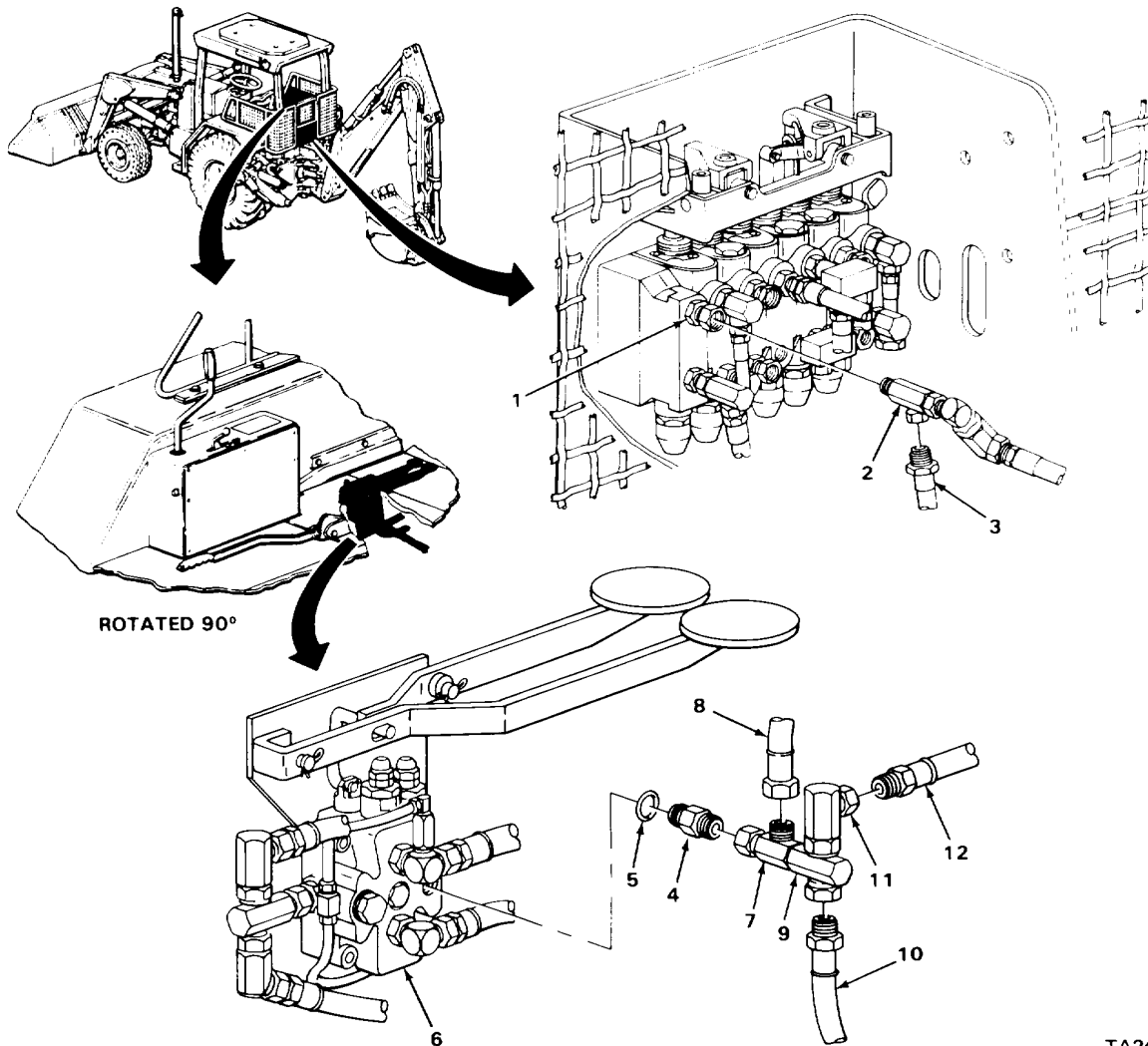

TA243423

JAW DIRECT LINEAR VALVE-TO-BACKHOE CONTROL VALVE OIL LINE (SERIAL NUMBERS 319995 THRU 342573 ONLY) - CONTINUED

LOCATION	ITEM	ACTION	REMARKS
INSTALLATION - CONTINUED			
39. Loader backhoe	Engine	If still running, shut down	(TM 5-2420-222-10).

NOTE

FOLLOW-ON MAINTENANCE: Install backhoe valve box cover (page 2-1157).

TASK ENDS HERE

MANIFOLD-TO-HYDRAULIC IMPACTOR VALVE OIL LINE (SERIAL NUMBERS 235786 THRU 235999 ONLY)

This task covers:

- a. Removal (page 2-1445)
- b. Cleaning (page 2-1446)
- c. Inspection/Replacement (page 2-1447)
- d. Installation (page 2-1448)

INITIAL SETUP:

Tools

- Pan, drain
- Wrench, open-end, 1 1/8-inch
- Wrench, open-end, 1 11/4-inch

Materials/Parts

- Detergent, GP (item 7, Appendix C)
- Rags, wiping (item 21, Appendix C)

Materials/Parts - Continued

- Solvent, drycleaning (item 28, Appendix C)
- Tags, marking (item 30, Appendix C)

Personnel Required

One

Equipment Condition

Hydraulic system pressure released
(page 2-1191)

2-1444

MANIFOLD-TO-HYDRAULIC IMPACTOR VALVE OIL LINE (SERIAL NUMBERS 235786 THRU 235999 ONLY) - CONTINUED

LOCATION	ITEM	ACTION	REMARKS
----------	------	--------	---------

REMOVAL

WARNING

Do not attempt to disconnect hydraulic lines and fittings while engine is running or before hydraulic system pressure has been released. When engine is running, hydraulic system is under pressure. Hydraulic system pressure should be 0 psi (0 kPa) before lines are disconnected. A line or fitting disconnected under pressure will blow off with a lot of force and could cause serious injury to personnel.

Be careful when draining hot fluids. Wear gloves to protect your hands from hot parts and fluids or severe burns could result.

- | | | |
|----------------------|--------------------------|--|
| 1. Elbow and packing | Hose (2)
assembly (1) | <ul style="list-style-type: none"> a. Place drain pan underneath. b. Using 1 1/4-inch open-end wrench, unscrew and take off. c. Tag (page 2-137). |
|----------------------|--------------------------|--|

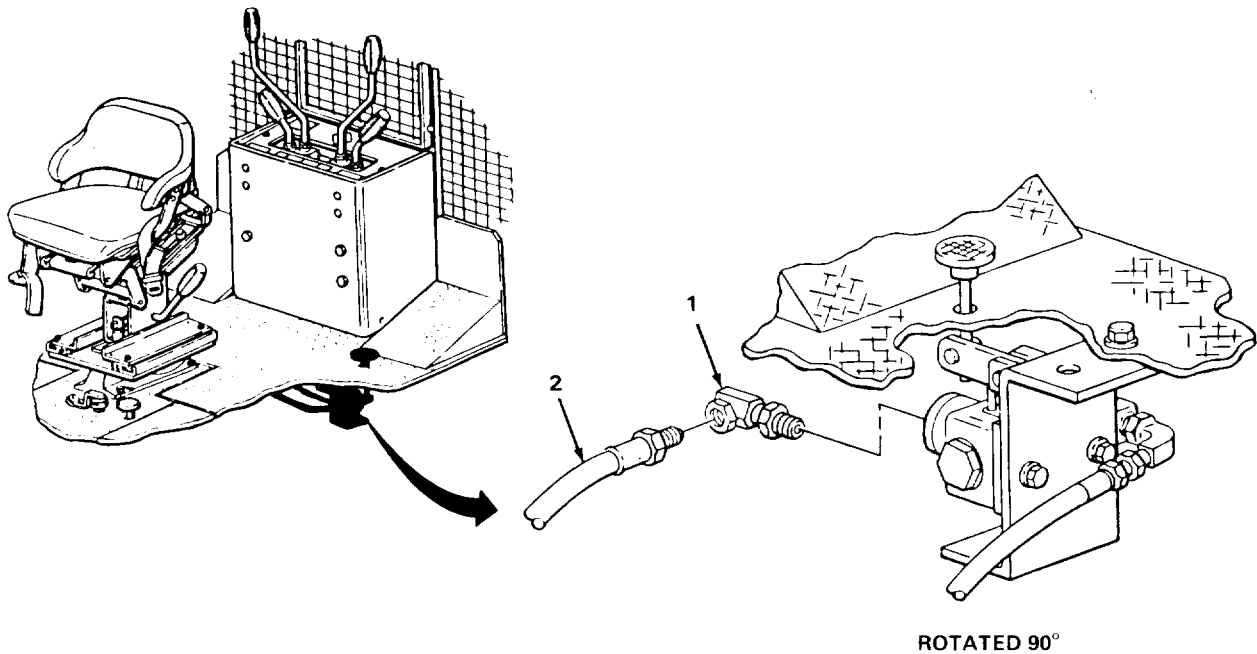

TA243424

MANIFOLD-TO-HYDRAULIC IMPACTOR VALVE OIL LINE (SERIAL NUMBERS 235786 THRU 235999 ONLY) - CONTINUED

LOCATION	ITEM	ACTION REMARKS
REMOVAL - CONTINUED		
2. Elbow and packing assembly (1) and valve (2)	Nut (3)	Using 1 1/8-inch and 1 1/4-inch open-end wrenches, loosen.
3. Valve (2)	Elbow and packing assembly (1)	<ul style="list-style-type: none"> a. Note relative position for proper placement during installation. b. Using 1 1/8-inch open-end wrench, unscrew and take out. c. Plug valve (2) (page 2-137).
4. Elbow and packing assembly (4)	Hose (5)	<ul style="list-style-type: none"> a. Place drain pan underneath. b. Using 1 1/4-inch open-end wrench, unscrew and take off. c. Tag (page 2-137).
5. Elbow and packing assembly (4) and manifold (6)	Nut (7)	Using 1 1/8-inch and 1 1/4-inch open-end wrenches, loosen.
6. Manifold (6)	Elbow and packing assembly (4)	<ul style="list-style-type: none"> a. Note relative position for proper placement during installation. b. Using 1 1/8-inch open-end wrench, unscrew and take out. c. Plug manifold (6) (page 2-137). d. Get rid of drained fluid (page 2-137).

CLEANING

NOTE

For more information on how to clean parts, go to General Maintenance Instructions (page 2-137).

- | | | |
|----|----------|---|
| 7. | Hose (5) | <ul style="list-style-type: none"> a. Using clean rags dampened in solution of detergent and water, wipe clean. b. Rinse with clean water. c. Using clean, dry rags, wipe dry. |
|----|----------|---|

MANIFOLD-TO-HYDRAULIC IMPACTOR VALVE OIL LINE (SERIAL NUMBERS 235786 THRU 235999 ONLY) - CONTINUED

LOCATION	ITEM	ACTION	REMARKS
----------	------	--------	---------

WARNING

Drycleaning solvent P-D-680 is toxic and flammable. Wear protective goggles and gloves and use only in a well ventilated area. Avoid contact with skin, eyes, and clothes and don't breathe vapors. Do not use near open flame or excessive heat. The flashpoint is 100°F to 138°F (38° to 59°C). If you become dizzy while using cleaning solvent, get fresh air immediately and get medical aid. If contact with eyes is made, wash your eyes with water and get medical aid immediately.

- | | | |
|----|-----------------|---|
| 8. | All metal parts | <ul style="list-style-type: none"> a. Clean in drycleaning solvent. b. Using clean, dry rags, wipe dry. |
|----|-----------------|---|

INSPECTION/REPLACEMENT

NOTE

For more information on how to inspect parts, go to General Maintenance Instructions (page 2-137).

Replace defective parts as needed.

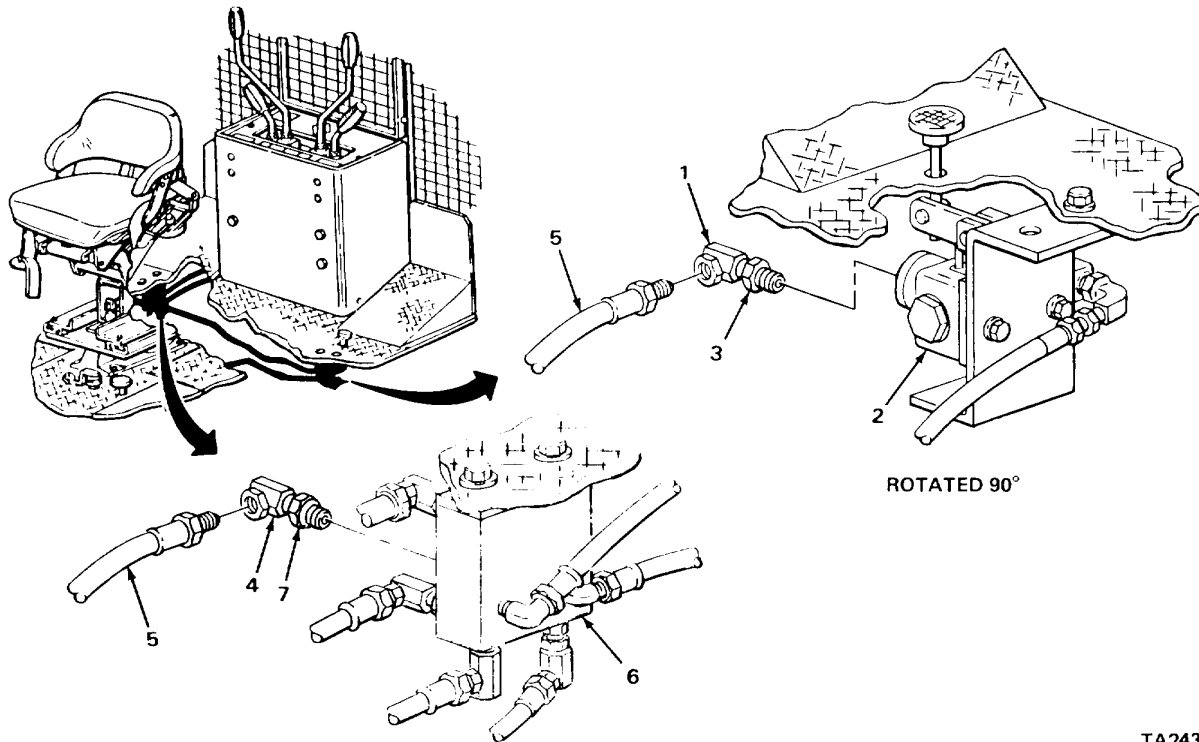

TA243425

MANIFOLD-TO-HYDRAULIC IMPACTOR VALVE OIL LINE (SERIAL NUMBERS 235786 THRU 235999 ONLY) - CONTINUED

LOCATION	ITEM	ACTION REMARKS
INSPECTION/REPLACEMENT- CONTINUED		
9.	Hose (1)	Look for cracks, breaks, tears and cuts.
10.	Two elbow and packing assemblies (2 and 3)	Look for damaged packings. If packing is damaged, complete assembly must be replaced.
11.	All metal parts	Look for cracks and breaks.
12.	All threaded parts	Look for damaged threads.
INSTALLATION		
13. Manifold (4)	Elbow and packing assembly (2)	a. Unplug manifold (4). b. Screw in and tighten to same relative position noted during removal using 1 1/8-inch open-end wrench.
14. Manifold (4) and elbow and packing assembly (2)	Nut (5)	Using 1 1/8-inch and 1 1/4-inch open-end wrenches, tighten until seated against manifold (4).
15. Elbow and packing assembly (2)	Hose (1)	a. Take off tag. b. Screw on and tighten using 1 1/4-inch open-end wrench.
16. Valve (6)	Elbow and packing assembly (3)	a. Unplug valve (6). b. Screw in and tighten to same relative position noted during removal using 1 1/8-inch open-end wrench.
17. Valve (6) and elbow and packing assembly (3)	Nut (7)	Using 1 1/8-inch and 1 1/4-inch open-end wrenches, tighten until seated against valve (6).
18. Elbow and packing assembly (3)	Hose (1)	a. Take off tag. b. Screw on and tighten using 1 1/4-inch open-end wrench.
19. Loader backhoe	Transmission	Check fluid level and add proper amount and grade (TM 5-2420-222-10).
20.	Engine	Start and run at high idle (TM 5-2420-222-10).

MANIFOLD-TO-HYDRAULIC IMPACTOR VALVE OIL LINE (SERIAL NUMBERS 235786 THRU 235999 ONLY) - CONTINUED

LOCATION	ITEM	ACTION	REMARKS
21.	Manifold-to-impactor valve oil line	a. Check for leaks. b. If leaking at any connection, tighten using 1 1/8-inch and 1 1/4-inch open-end wrenches. c. If leaking does not stop, shut down engine (TM 5-2420-222-10) and replace leaking connection packing, fitting, or hose as outlined in this task. d. If found leaking, repeat steps 19 thru 21.	
22.	Engine	If still running, shut down (TM 5-2420-222-10).	

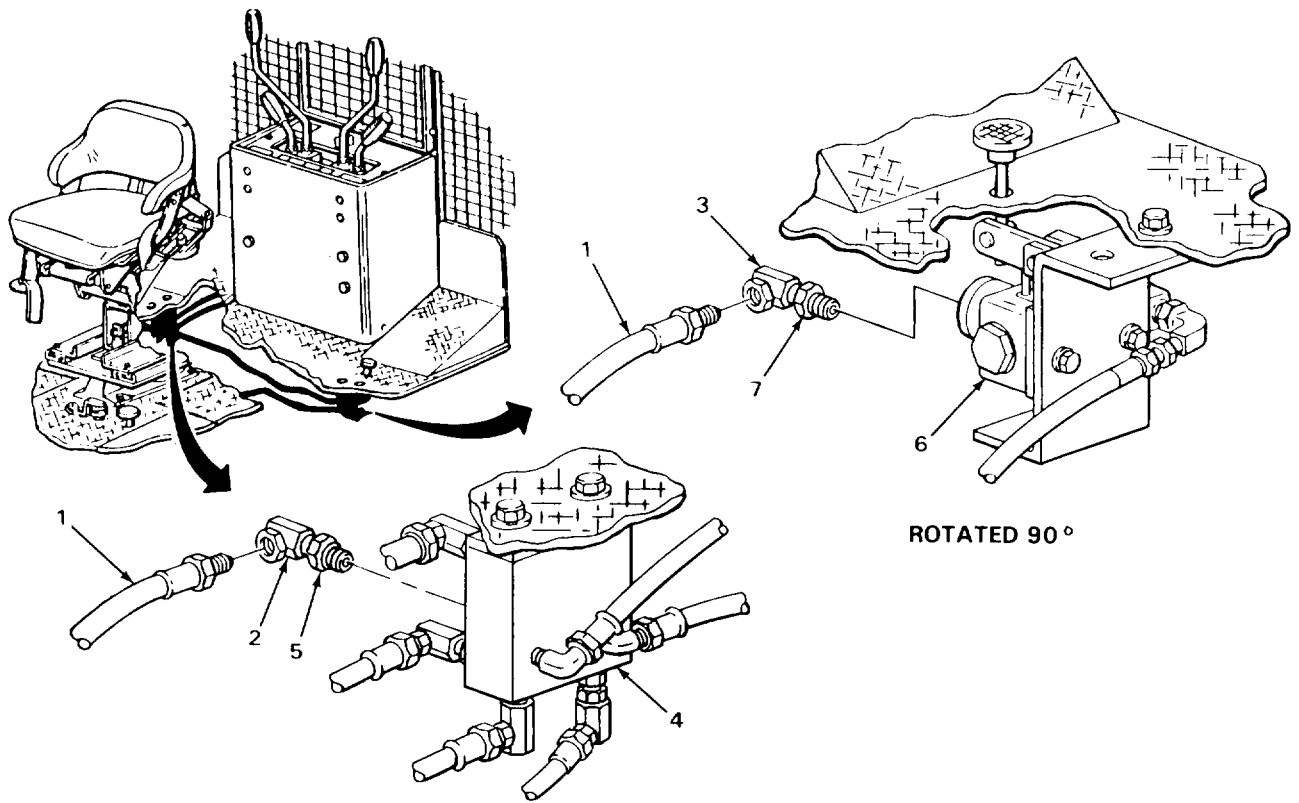

TASK ENDS HERE

MANIFOLD-TO-HYDRAULIC IMPACTOR VALVE OIL LINE (SERIAL NUMBERS 235786 THRU 235999 ONLY) - CONTINUED

This task covers:

- | | |
|---------------------------|---|
| a. Removal (page 2-1450) | c. Inspection/Replacement (page 2-1452) |
| b. Cleaning (page 2-1452) | d. Installation (page 2-1453) |

INITIAL SETUP:

Tools

- Knife, pocket
- Pan, drain
- Wrench, open-end, 1 1/16-inch
- Wrench, open-end, 1 1/4-inch (two required)

Materials/Parts

- Detergent, GP (item 7, Appendix C)
- Packing, union adapter

Materials/Parts - Continued

- Rags, wiping (item 21, Appendix C)
- Solvent, drycleaning (item 28, Appendix C)
- Tags, marking (item 30, Appendix C)

Personnel Required

One

Equipment Condition

Hydraulic system pressure released (page 2-1191)

LOCATION	ITEM	ACTION	REMARKS
----------	------	--------	---------

REMOVAL

WARNING

Do not attempt to disconnect hydraulic lines and fittings while engine is running or before hydraulic system pressure has been released. When engine is running, hydraulic system is under pressure. Hydraulic system pressure should be 0 psi (0 kPa) before lines are disconnected. A line or fitting disconnected under pressure will blow off with a lot of force and could cause serious injury to personnel.

Be careful when draining hot fluids. Wear gloves to protect your hands from hot parts and fluids or severe burns could result.

- | | | |
|----------------------|--|--|
| 1. Union adapter (1) | Hose (2) | <ul style="list-style-type: none"> a. Place drain pan underneath. b. Using 1 1/16-inch and 1 1/4-inch open-end wrenches, unscrew and take out. c. Tag (page 2-137). |
| 2. Valve (3) | Union adapter (1) with assembled packing (4) | <ul style="list-style-type: none"> a. Using 1 1/4-inch open-end wrench, unscrew and take out. b. Plug valve (3) (page 2-137). |

MANIFOLD-TO-HYDRAULIC IMPACTOR VALVE OIL LINE (SERIAL NUMBERS 235786 THRU 235999 ONLY) - CONTINUED

LOCATION	ITEM	ACTION	REMARKS
3. Union adapter (1)	Packing (4)	a. Using pocket knife, take off. b. Get rid of.	
4. Union adapter (5)	Hose (2)	a. Place drain pan underneath. b. Using 1 1/16-inch and 1 1/4-inch open-end wrenches, unscrew and take out. c. Tag (page 2-137).	
5. Union adapter (5) and manifold (6)	Nut (7)	Using two 1 1/4-inch open-end wrenches, loosen.	

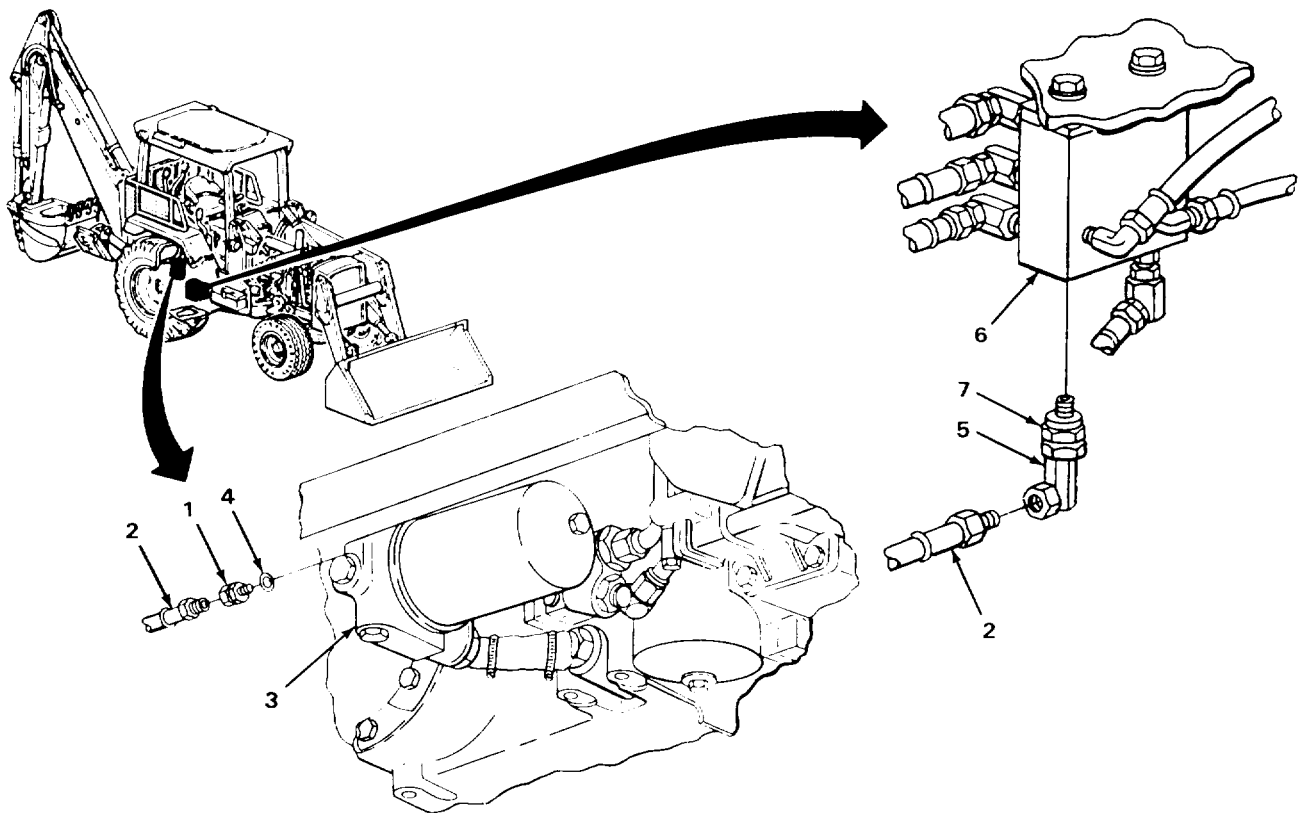

TA243427

MANIFOLD-TO-HYDRAULIC IMPACTOR VALVE OIL LINE (SERIAL NUMBERS 235786 THRU 235999 ONLY) - CONTINUED

LOCATION	ITEM	ACTION	REMARKS
REMOVAL- CONTINUED			
6. Manifold (1)	Union adapter (2) with assembled parts	a. Note relative position for proper placement during installation. b. Using 1 1/4-inch open-end wrench, unscrew and take out. c. Plug manifold (1) (page 2-137). d. Get rid of drained fluid (page 2-137).	
7. Union adapter (2)	Packing (3)	a. Using pocket knife, take off. b. Get rid of.	

CLEANING**NOTE**

For more information on how to clean parts, go to General Maintenance Instructions (page 2-137).

- | | | | |
|----|----------|---|--|
| 8. | Hose (4) | a. Using clean rags dampened in solution of detergent and water, wipe clean.
b. Rinse with clean water.
c. Using clean, dry rags, wipe dry. | |
|----|----------|---|--|

WARNING

Drycleaning solvent P-D-680 is toxic and flammable. Wear protective goggles and gloves and use only in a well ventilated area. Avoid contact with skin, eyes, and clothes and don't breathe vapors. Do not use near open flame or excessive heat. The flashpoint is 100°F to 138°F (38° to 59°C). If you become dizzy while using cleaning solvent, get fresh air immediately and get medical aid. If contact with eyes is made, wash your eyes with water and get medical aid immediately.

- | | | | |
|----|-----------------|---|--|
| 9. | All metal parts | a. Clean in drycleaning solvent.
b. Using clean, dry rags, wipe dry. | |
|----|-----------------|---|--|

INSPECTION/REPLACEMENT**NOTE**

For more information on how to inspect parts, go to General Maintenance Instructions (page 2-137).

Replace defective parts as needed.

**MANIFOLD-TO-HYDRAULIC OIL FILTER RELIEF VALVE OIL LINE (SERIAL NUMBERS 235786 THRU 235999 ONLY)
- CONTINUED**

LOCATION	ITEM	ACTION	REMARKS
10	Hose (4)		Look for cracks, breaks, tears and cuts.
11	All metal parts		Look for cracks and breaks.
12	All threaded parts		Look for damaged threads.
INSTALLATION			
13	Union adapter (2)	Nut (5)	Screw on all the way.
14		New packing (3)	Place in position.
15	Manifold (1)	Union adapter (2) with assembled parts	a. Unplug manifold (1). b. Screw in and tighten to position noted during removal using 1 1/4-inch open-end wrench.
16	Manifold (1) and and union adapter (2)	Nut (5)	Using two 1 1/4-inch open-end wrenches, tighten until seated against manifold (1).
17	Union adapter (1)	Hose (4)	a. Take off tag. b. Screw on and tighten using 1 1/16-inch and 1 1/4-inch open-end wrenches.

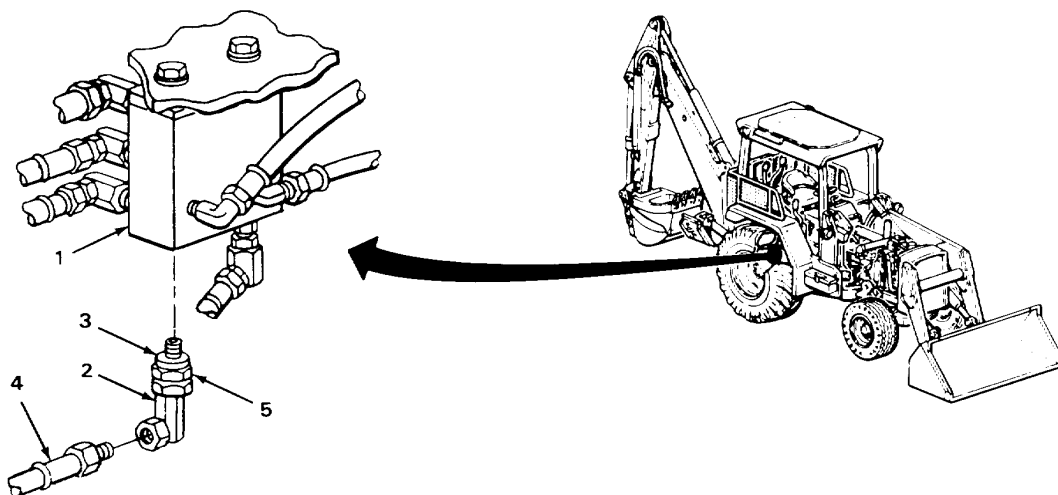

TA243428

**MANIFOLD-TO-HYDRAULIC OIL FILTER RELIEF VALVE OIL LINE (SERIAL NUMBERS 235786 THRU 235999 ONLY)
- CONTINUED**

LOCATION	ITEM	ACTION REMARKS
INSTALLATION - CONTINUED		
18 Union adapter (1)	New packing (2)	Place in position.
19 Valve (3)	Union adapter (1) with assembled packing (2)	a. Unplug valve (4). b. Screw in and tighten using 1 1/4- inch open-end wrench.
20 Union adapter (1)	Hose (4)	a. Take off tag. b. Screw on and tighten using 1 1/16- inch and 1 1/4-inch open-end wrenches.
21 Loader backhoe	Transmission	Check fluid level and add proper amount and grade (TM 5-2420-222-10).
22	Engine	Start and run at high idle (TM 5-2420-222-10).
23	Manifold-to- hydraulic oil filter relief valve oil line	a. Check for leaks. b. If leaking at any connection, tighten using 1 1/16-inch and two 1 1/4-inch open-end wrenches. c. If leaking does not stop, shut down engine (TM 5-2420-222-10) and replace leaking connection packing, fitting, or hose as outlined in this task. d. If found leaking, repeat steps 21 thru 23.
24	Engine	If still running, shut down (TM 5-2420-222-10).

MANIFOLD-TO-HYDRAULIC OIL FILTER RELIEF VALVE OIL LINE (SERIAL NUMBERS 235786 THRU 235999 ONLY)
- CONTINUED

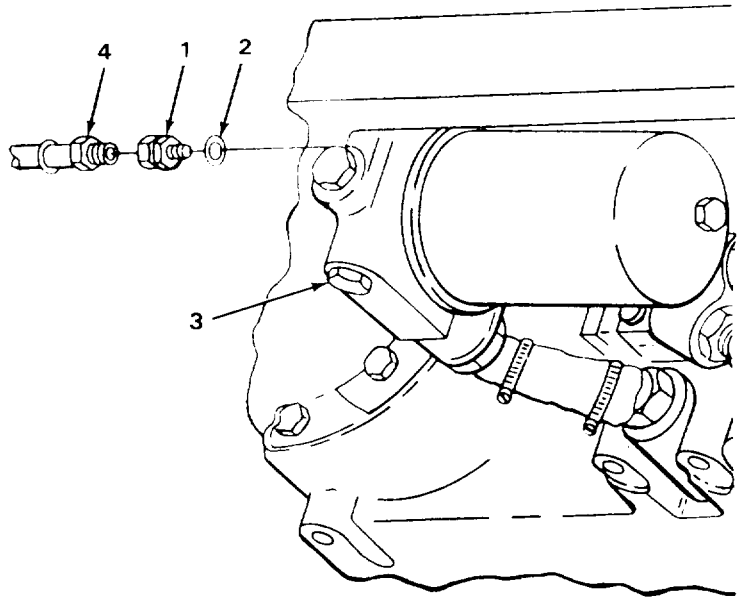
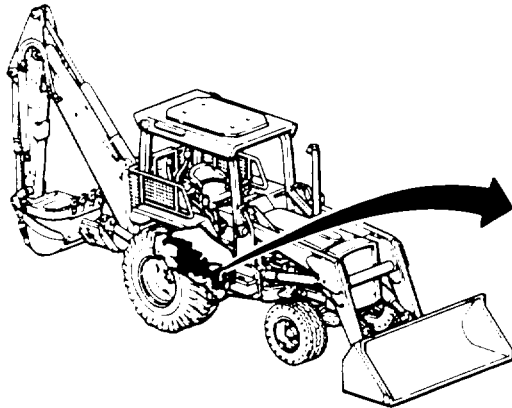

VIEW LOOKING UP

TASK ENDS HERE

MANIFOLD-TO-JAW CONTROL VALVE OIL LINES (SERIAL NUMBERS 235786 THRU 235999 ONLY)

This task covers:

- | | |
|---------------------------|---|
| a. Removal (page 2-1456) | c. Inspection/Replacement (page 2-1460) |
| b. Cleaning (page 2-1459) | d. Installation (page 2-1460) |

INITIAL SETUP

<p>Tools</p> <p>Knife, pocket Pan, drain Wrench, open-end</p> <p>Materials/Parts</p> <p>Detergent, GP (item 7, Appendix C) Packing, elbow Packing, straight adapter</p>	<p>Materials/Parts - Continued</p> <p>Rags, wiping (item 21, Appendix C) Solvent, drycleaning (item 28, Appendix C) Tags, marking (item 30, Appendix C)</p> <p>Personnel Required</p> <p>One</p> <p>Equipment Condition</p> <p>Hydraulic system pressure released (page 2-1191)</p>
---	---

LOCATION	ITEM	ACTION	REMARKS
----------	------	--------	---------

NOTE

Both manifold-to-jaw control valve oil lines are maintained the same way except as noted. Return oil line is shown. Repeat procedures as needed for pressure oil line.

REMOVAL

WARNING

Do not attempt to disconnect hydraulic lines and fittings while engine is running or before hydraulic system pressure has been released. When engine is running, hydraulic system is under pressure. Hydraulic system pressure should be 0 psi (0 kPa) before lines are disconnected. A line or fitting disconnected under pressure will blow off with a lot of force and could cause serious injury to personnel.

Be careful when draining hot fluids. Wear gloves to protect your hands from hot parts and fluids or severe burns could result.

MANIFOLD-TO-JAW CONTROL VALVE OIL LINES (SERIAL NUMBERS 235786 THRU 235999 ONLY) - CONTINUED

LOCATION	ITEM	ACTION REMARKS
1. Elbow (1)	Hose (2)	a. Place drain pan underneath. b. Using open-end wrench, unscrew and take off. c. Tag (page 2-137).
2. Elbow (1) and manifold (3)	Nut (4)	Using open-end wrenches, loosen.
3. Manifold (3)	Elbow (1) with assembled parts	a. Note relative position for proper placement during installation. b. Using open-end wrench, unscrew and take out. c. Plug manifold (3) (page 2-137). d. Get rid of drained fluid (page 2-137).
4. Elbow (1)	Packing (5)	a. Using pocket knife, take off. b. Get rid of.

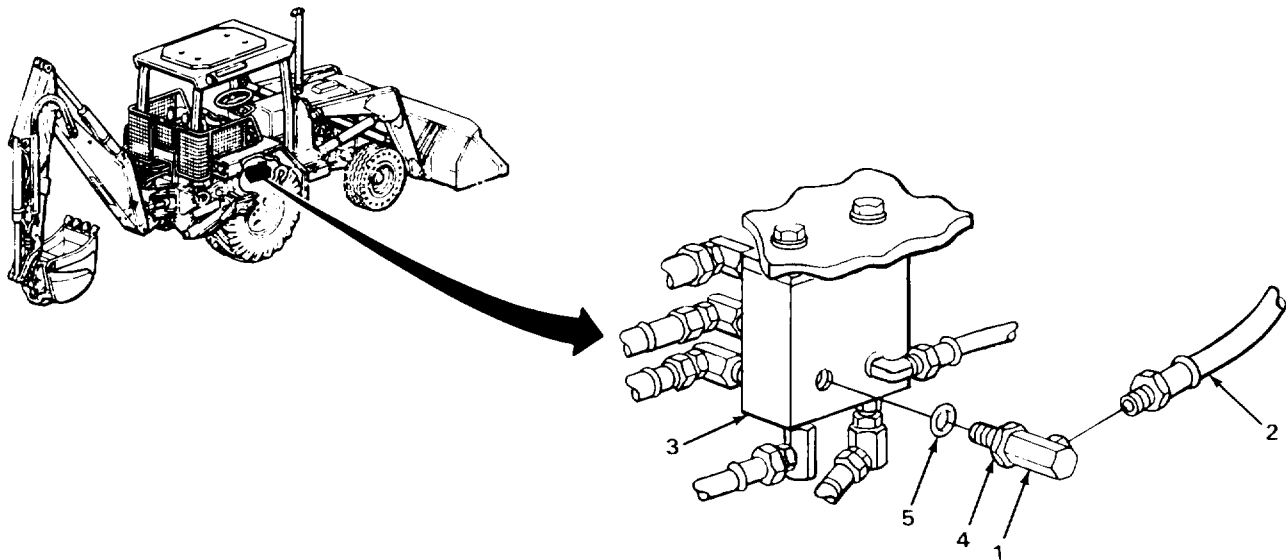

MANIFOLD-TO-JAW CONTROL VALVE OIL LINES (SERIAL NUMBERS 235786 THRU 235999 ONLY) - CONTINUED

LOCATION	ITEM	ACTION REMARKS
REMOVAL - CONTINUED		
NOTE		
If pressure oil line is being removed, skip steps 5 thru 8.		
5 Elbow (1)	Hose (2)	a. Place drain pan underneath. b. Using open-end wrench, unscrew and take off. c. Tag (page 2-137).
6. Straight adapter (3)	Elbow (1)	a. Note relative position for proper placement during installation. b. Using open-end wrenches, unscrew and take out.
7. Valve (4)	Straight adapter (3) with assembled packing (5)	a. Using open-end wrench, unscrew and take out. b. Plug valve (4) (page 2-137). c. Get rid of drained fluid (page 2-137).
8. Straight adapter (3)	Packing (5)	a. Using pocket knife, take off. b. Get rid of.
NOTE		
If return oil line is being removed, skip steps 9 thru 11.		
9. Straight adapter (6)	Hose (7)	a. Place drain pan underneath. b. Using open-end wrenches, unscrew and take off. c. Tag (page 2-137).
10 Valve (4)	Straight adapter (6) with assembled packing (8)	a. Using open-end wrench, unscrew and take out. b. Plug valve (4) (page 2-137). c. Get rid of drained fluid (page 2-137).
11. Straight adapter (6)	Packing (8)	a. Using pocket knife, take off. b. Get rid of.

MANIFOLD-TO-JAW CONTROL VALVE OIL LINES (SERIAL NUMBERS 235786 THRU 235999 ONLY) - CONTINUED

LOCATION	ITEM	ACTION	REMARKS
----------	------	--------	---------

CLEANING

NOTE

For more information on how to clean parts, go to General Maintenance Instructions (page 2-137).

12	Hose (2 or 7)	a. Using clean rags dampened in solution of detergent and water, wipe clean. b. Rinse with clean water. c. Using clean, dry rags, wipe dry.
----	---------------	---

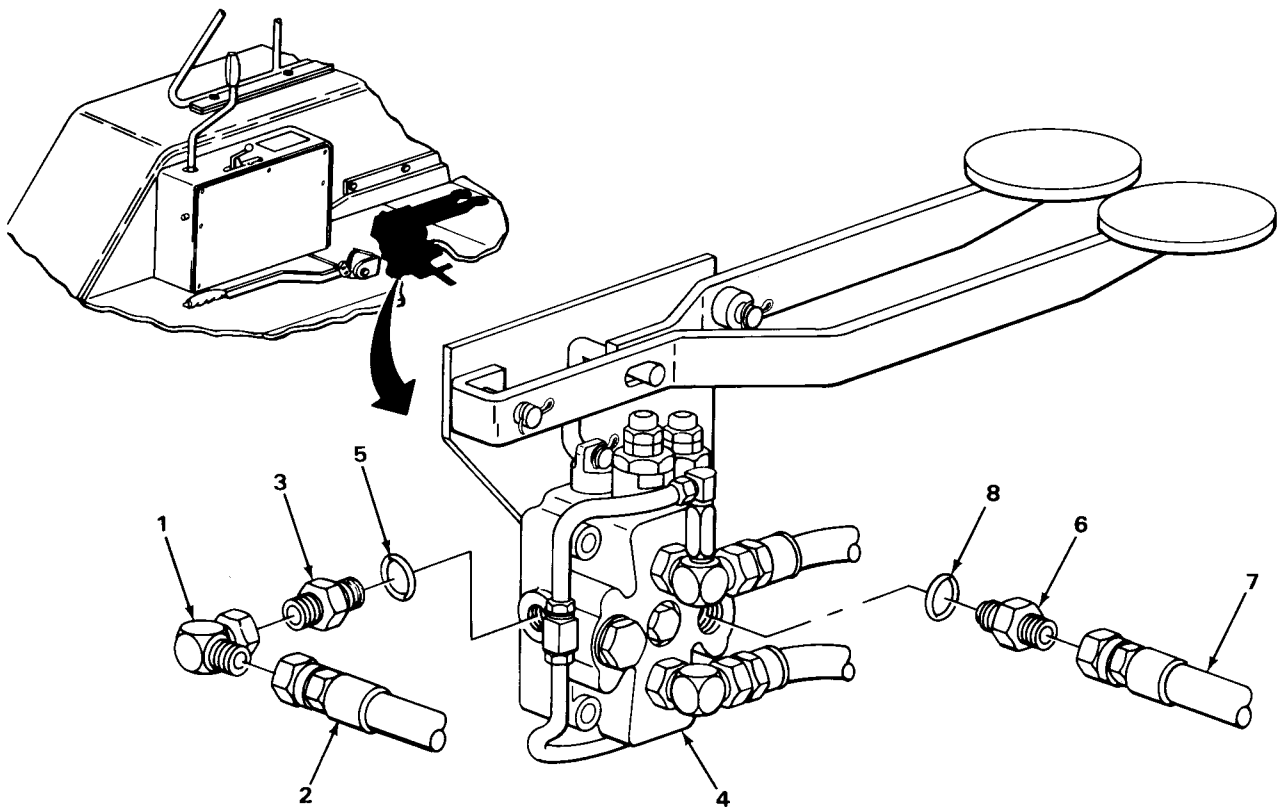

TA243431

MANIFOLD-TO-JAW CONTROL VALVE OIL LINES (SERIAL NUMBERS 235786 THRU 235999 ONLY) - CONTINUED

LOCATION	ITEM	ACTION	REMARKS
----------	------	--------	---------

CLEANING - CONTINUED

WARNING

Drycleaning solvent P-D-680 is toxic and flammable. Wear protective goggles and gloves and use only in a well ventilated area. Avoid contact with skin, eyes, and clothes and don't breathe vapors. Do not use near open flame or excessive heat. The flashpoint is 100°F to 138°F (38° to 59°C). If you become dizzy while using cleaning solvent, get fresh air immediately and get medical aid. If contact with eyes is made, wash your eyes with water and get medical aid immediately.

13	All metal parts	a. Clean in drycleaning solvent. b. Using clean, dry rags, wipe dry.	
----	-----------------	---	--

INSPECTION/REPLACEMENT

NOTE

For more information on how to inspect parts, go to General Maintenance Instructions (page 2-137).

Replace defective parts as needed.

14	Hose (1 or 2)	Look for cracks, breaks, cuts, and tears.	
15	All metal parts	Look for cracks and breaks.	

INSTALLATION

NOTE

If return oil line is being installed, skip steps 16 thru 18.

16	Straight adapter (3)	New packing (4)	Place in position.
17	Valve (5)	Straight adapter (3) with assembled packing (4)	a. Unplug valve (5). b. Screw in and tighten using open-end wrench.
18	Straight adapter (3)	Hose (1)	a. Take off tag. b. Screw on and tighten using open-end wrench.

MANIFOLD-TO-JAW CONTROL VALVE OIL LINES (SERIAL NUMBERS 235786 THRU 235999 ONLY) - CONTINUED

LOCATION	ITEM	ACTION	REMARKS
----------	------	--------	---------

NOTE

If pressure oil line is being installed, skip steps 19 thru 22.

19 Straight adapter (6)	New packing (7)	Place in position.	
20 Valve (5)	Straight adapter (6) with assembled packing (7)	a. Unplug valve (5). b. Screw in and tighten using open-end wrench.	
21 Straight adapter (6)	Elbow (8)	Screw on and tighten to same relative position noted during removal using open-end wrenches.	
22 Elbow (8)	Hose (2)	a. Take off tag. b. Screw on and tighten using open-end wrench.	

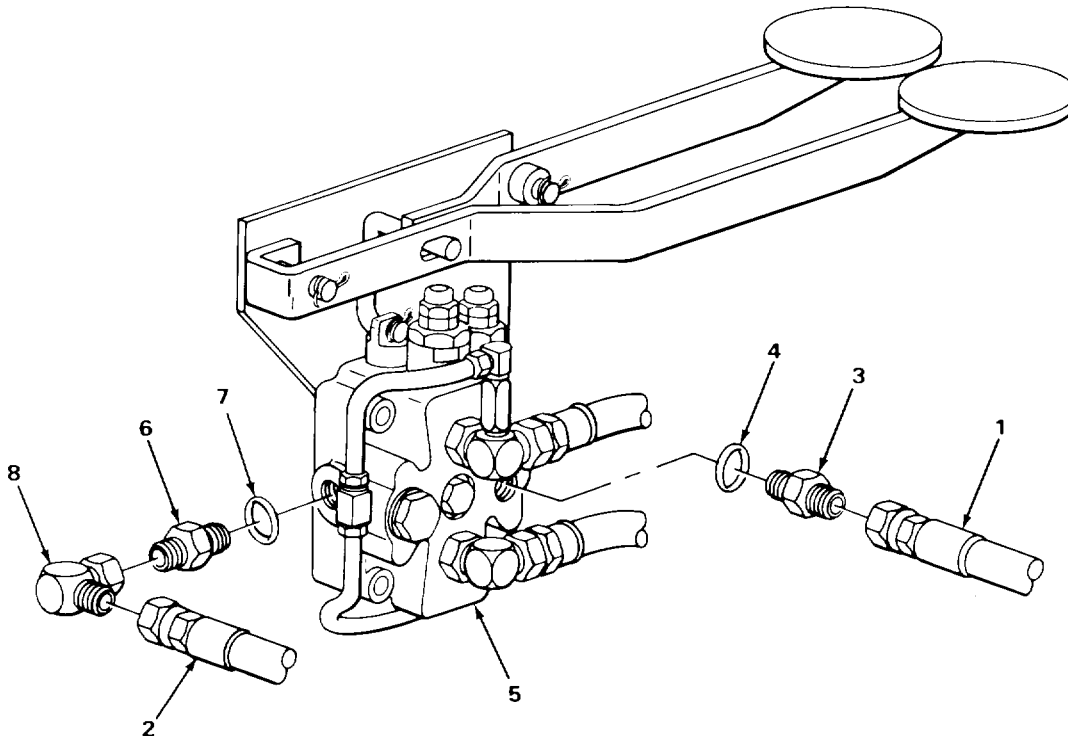

TA243432

MANIFOLD-TO-JAW CONTROL VALVE OIL LINES (SERIAL NUMBERS 235786 THRU 235999 ONLY) - CONTINUED

LOCATION	ITEM	ACTION REMARKS
INSTALLATION - CONTINUED		
23 Elbow (1)	Nut (2)	Screw on all the way.
24	New packing (3)	Place in position.
25 Manifold (4)	Elbow (1) with attached parts	a. Unplug manifold (4). b. Screw in and tighten to same relative position noted during removal using open-end wrench.
26 Elbow (1) and manifold (4)	Nut (2) seated against manifold (4).	Using open-end wrenches, tighten until
27 Elbow (1)	Hose (5)	a. Take off tag. b. Screw on and tighten using open-end wrenches.
28 Loader backhoe	Transmission	Check fluid level and add proper amount and grade (TM 5-2420-222-10).
29	Engine	Start and run at high idle (TM 5-2420-222-10).
30	Manifold-to-jaw control valve oil lines	a. Check for leaks. b. If leaking at any connection, tighten using open-end wrenches. c. If leaking does not stop, shut down engine (TM 5-2420-222-10) and replace leaking connection packing, fitting, or hose as outlined in this task. d. If found leaking, repeat steps 28 thru 30.
31	Engine	If still running, shut down (TM 5-2420-222-10).

MANIFOLD-TO-JAW CONTROL VALVE OIL LINES (SERIAL NUMBERS 235786 THRU 235999 ONLY) - CONTINUED

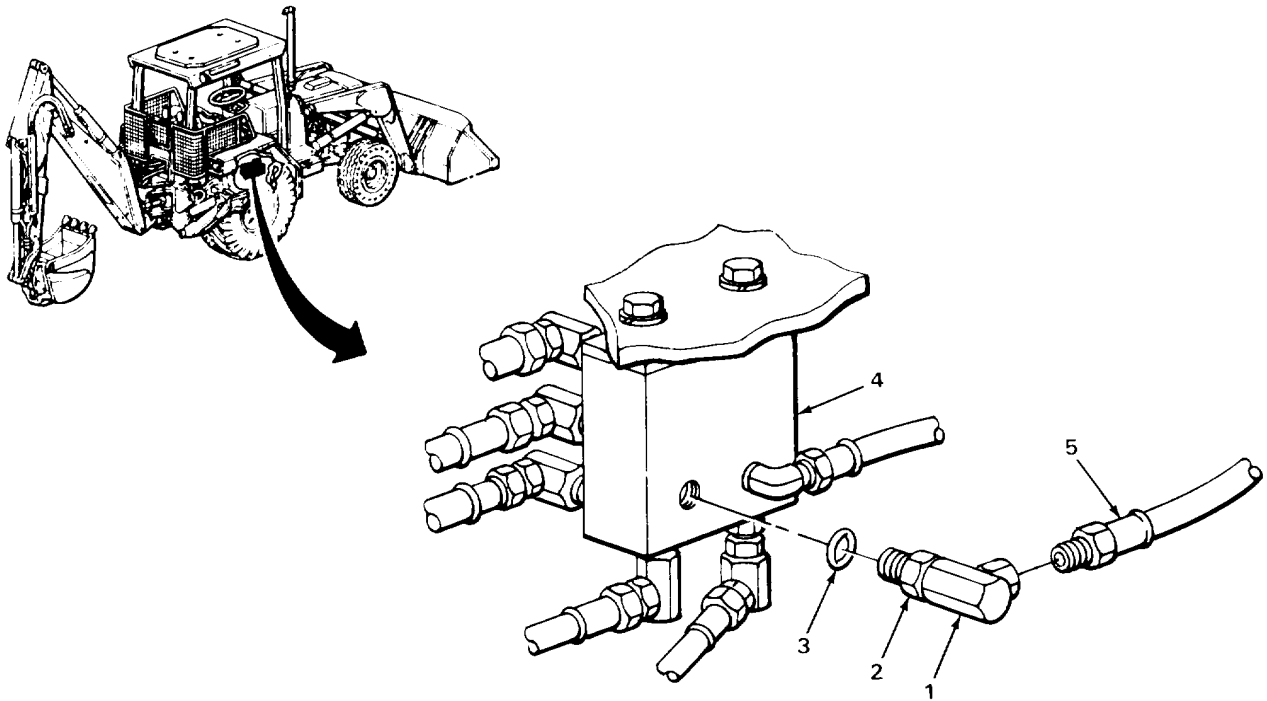

TASK ENDS HERE

2-1463

TA243433

JAW DIRECT LINEAR VALVE-TO-HYDRAULIC OIL FILTER RELIEF VALVE OIL LINE (SERIAL NUMBERS 319995 THRU 342573 ONLY)

This task covers:

- a. Removal (page 2-1464)
- b. Disassembly (page 2-1466)
- c. Cleaning (page 2-1467)
- d. Inspection/Replacement (page 2-1468)
- e. Assembly (page 2-1468)
- f. Installation (page 2-1468)

INITIAL SETUP

Tools

- Handle, ratchet, 3/4-inch drive
- Knife, pocket
- Pan, drain
- Socket, 3/4-inch drive, 1 1/2-inch
- Vise, machinist's
- Wrench, open-end, 1 1/8-inch
- Wrench, open-end, 1 1/4-inch (two required)

Materials/Parts

- Detergent, GP (item 7, Appendix C)
- Packing, connector
- Packing, union adapter

Materials/Parts - Continued

- Rags, wiping (item 21, Appendix C)
- Solvent, drycleaning (item 28, Appendix C)
- Tags, marking (item 30, Appendix C)

Personnel Required

One

Equipment Condition

1. Hydraulic system pressure released (page 2-1191)
2. Left rear platform removed (page 2-1114)

LOCATION	ITEM	ACTION	REMARKS
----------	------	--------	---------

REMOVAL

WARNING

Do not attempt to disconnect hydraulic lines and fittings while engine is running or before hydraulic system pressure has been released. When engine is running, hydraulic system is under pressure. Hydraulic system pressure should be 0 psi (0 kPa) before lines are disconnected. A line or fitting disconnected under pressure will blow off with a lot of force and could cause serious injury to personnel.

Be careful when draining hot fluids. Wear gloves to protect your hands from hot parts and fluids or severe burns could result.

- | | | | |
|---|-------------------|----------|---|
| 1 | Union adapter (1) | Hose (2) | <ul style="list-style-type: none"> a. Place drain pan underneath. b. Using 1 1/8-inch and 1 1/4-inch open-end wrenches, unscrew and take out. c. Tag (page 2-137). |
|---|-------------------|----------|---|

JAW DIRECT LINEAR VALVE-TO-HYDRAULIC OIL FILTER RELIEF VALVE OIL LINE (SERIAL NUMBERS 319995 THRU 342573 ONLY) - CONTINUED

LOCATION	ITEM	ACTION REMARKS
2. Hydraulic oil filter relief valve (3)	Union adapter (1) with assembled packing (4)	a. Using 1 1/4-inch open-end wrench, unscrew and take out. b. Plug valve (3) (page 2-137).
3. Union adapter (1)	Packing (4)	a. Using pocket knife, take off. b. Get rid of.

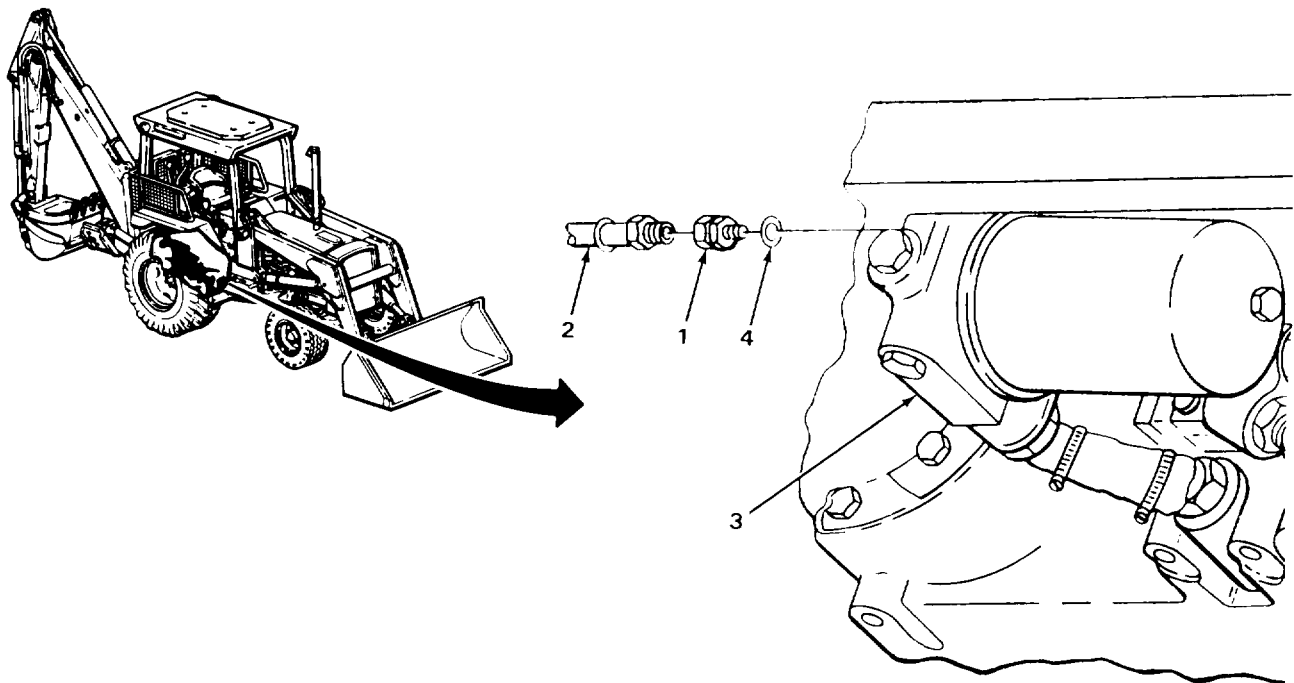

TA243434

JAW DIRECT LINEAR VALVE-TO-HYDRAULIC OIL FILTER RELIEF VALVE OIL LINE (SERIAL NUMBERS 319995 THRU 342573 ONLY) - CONTINUED

LOCATION	ITEM	ACTION REMARKS
REMOVAL - CONTINUED		
4. Union adapter (1)	Hose (2)	a. Place drain pan underneath. b. Using 1 1/8-inch and 1 1/4-inch open-end wrenches, unscrew and take out. c. Tag (page 2-137).
5. Elbow (3)	Hose (4)	a. Using 1 1/8-inch and 1 1/4-inch open-end wrenches, unscrew and take out. b. Cap (page 2-137). c. Tag (page 2-137).
6. Connector (5)	Tee (6) with assembled parts	a. Note relative position for proper placement during installation. b. Using 1 1/4-inch open-end wrench, unscrew and take out.
7. Jaw direct linear valve (7)	Connector (5) with assembled packing (8)	a. Using 1 1/2-inch, 3/4-inch drive socket and ratchet handle, unscrew and take out. b. Plug valve (7) (page 2-137). c. Get rid of drained fluid (page 2-137).
8. Connector (5)	Packing (8)	a. Using pocket knife, take off. b. Get rid of.
DISASSEMBLY		
9. Union adapter (1)	Tee (6) with assembled elbow (3)	a. Place union adapter (1) in machinist's vise. b. Note relative position for proper placement during assembly. c. Using 1 1/4-inch open-end wrench, unscrew and take off. d. Take union adapter (1) out of machinist's vise.
10 Elbow (3)	Tee (6)	a. Place elbow (3) in machinist's vise. b. Note relative position for proper placement during assembly. c. Using 1 1/4-inch open-end wrench, unscrew and take off. d. Take elbow (3) out of machinist's vise.

JAW DIRECT LINEAR VALVE-TO-HYDRAULIC OIL FILTER RELIEF VALVE OIL LINE (SERIAL NUMBERS 319995 THRU 342573 ONLY) - CONTINUED

LOCATION	ITEM	ACTION	REMARKS
----------	------	--------	---------

CLEANING

NOTE

For more information on how to clean parts, go to General Maintenance Instructions (page 2-137).

WARNING

Drycleaning solvent P-D-680 is toxic and flammable. Wear protective goggles and gloves and use only in a well ventilated area. Avoid contact with skin, eyes, and clothes and don't breathe vapors. Do not use near open flame or excessive heat. The flashpoint is 100°F to 138°F (38° to 59°C). If you become dizzy while using cleaning solvent, get fresh air immediately and get medical aid. If contact with eyes is made, wash your eyes with water and get medical aid immediately.

- | | | |
|----|-----------------|---|
| 11 | All metal parts | <ul style="list-style-type: none"> a. Clean in drycleaning solvent. b. Using clean, dry rags, wipe dry. |
|----|-----------------|---|

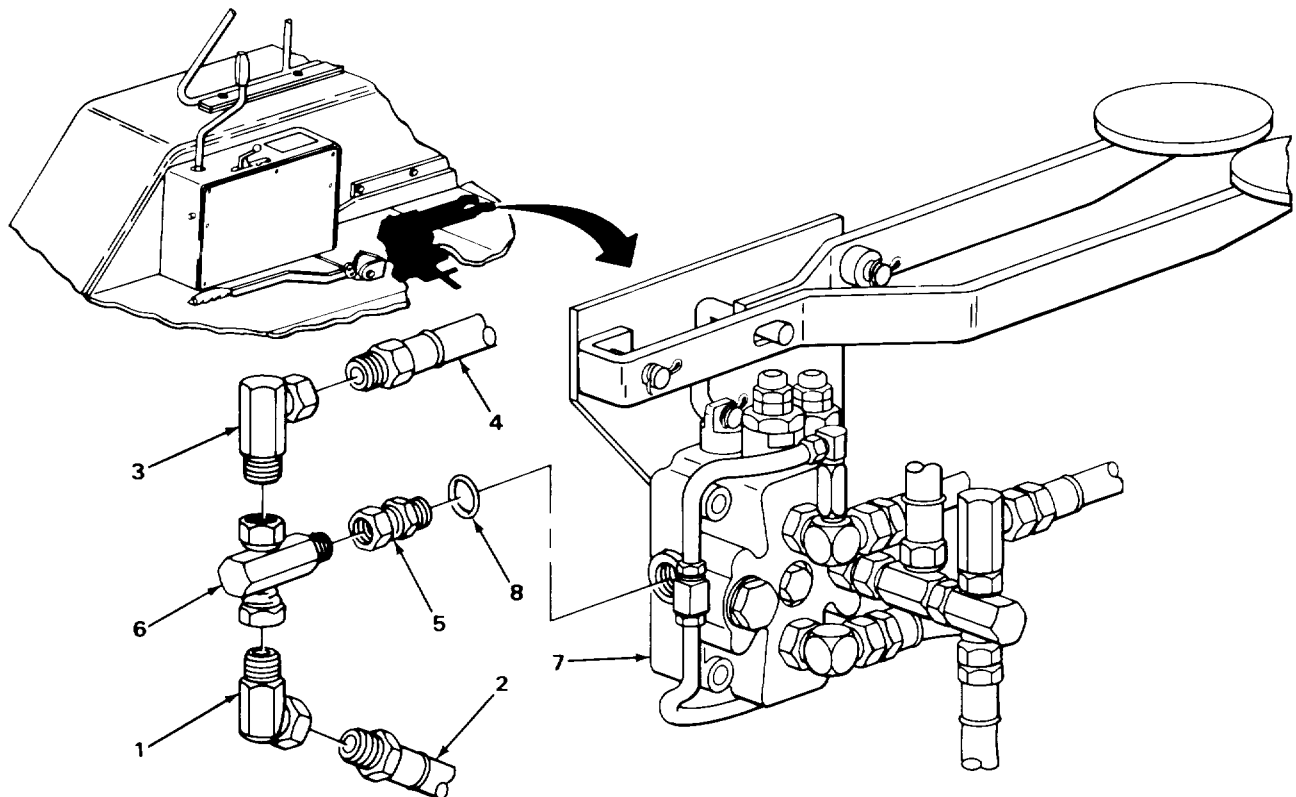

TA243435

JAW DIRECT LINEAR VALVE-TO-HYDRAULIC OIL FILTER RELIEF VALVE OIL LINE (SERIAL NUMBERS 319995 THRU 342573 ONLY) - CONTINUED

LOCATION	ITEM	ACTION	REMARKS
CLEANING - CONTINUED			
12	Hose (1)	a. Using clean rags dampened in solution of detergent and water, wipe clean. b. Rinse with clean water. c. Using clean, dry rags, wipe dry.	
INSPECTION/REPLACEMENT			
NOTE			
<p>For more information on how to inspect parts, go to General Maintenance Instructions (page 2-137).</p>			
<p>Replace defective parts as needed.</p>			
13	Hose (1)		Look for cracks, breaks, cuts, and tears.
14	All metal parts		Look for cracks and breaks.
15	All threaded parts		Look for damaged threads.
ASSEMBLY			
16 Elbow (2)	Tee (3)		a. Place elbow (2) in machinist's vise. b. Screw in and tighten to same relative position noted during disassembly using 1 1/4-inch open-end wrench. c. Take elbow (2) out of machinist's vise.
17 Union adapter (4)	Tee (3) with assembled elbow (2)		a. Place union adapter (4) in machinist's vise. b. Screw in and tighten to same relative position noted during disassembly using 1 1/4-inch open-end wrench. c. Take union adapter (4) out of machinist's vise.
INSTALLATION			
18 Connector (5)	New packing (6)		Place in position.

JAW DIRECT LINEAR VALVE-TO-HYDRAULIC OIL FILTER RELIEF VALVE OIL LINE (SERIAL NUMBERS 319995 THRU 342573 ONLY) - CONTINUED

LOCATION	ITEM	ACTION REMARKS
19. Jaw direct linear valve (7)	Connector (5) with assembled packing (6)	a. Unplug valve (7). b. Screw in and tighten using 1 1/2-inch, 3/4-inch drive socket and ratchet handle.
20 Connector (5)	Tee (3) with assembled parts	Screw on and tighten to same relative position noted during removal using two 1 1/4-inch open-end wrenches.
21 Elbow (2)	Hose (3)	a. Take off tag. b. Uncap. c. Screw in and tighten using 1 1/8-inch and 1 1/4-inch open-end wrenches.
22 Union adapter (4)	Hose (1)	a. Take off tag. b. Screw in and tighten using 1 1/8-inch and 1 1/4-inch open-end wrenches.

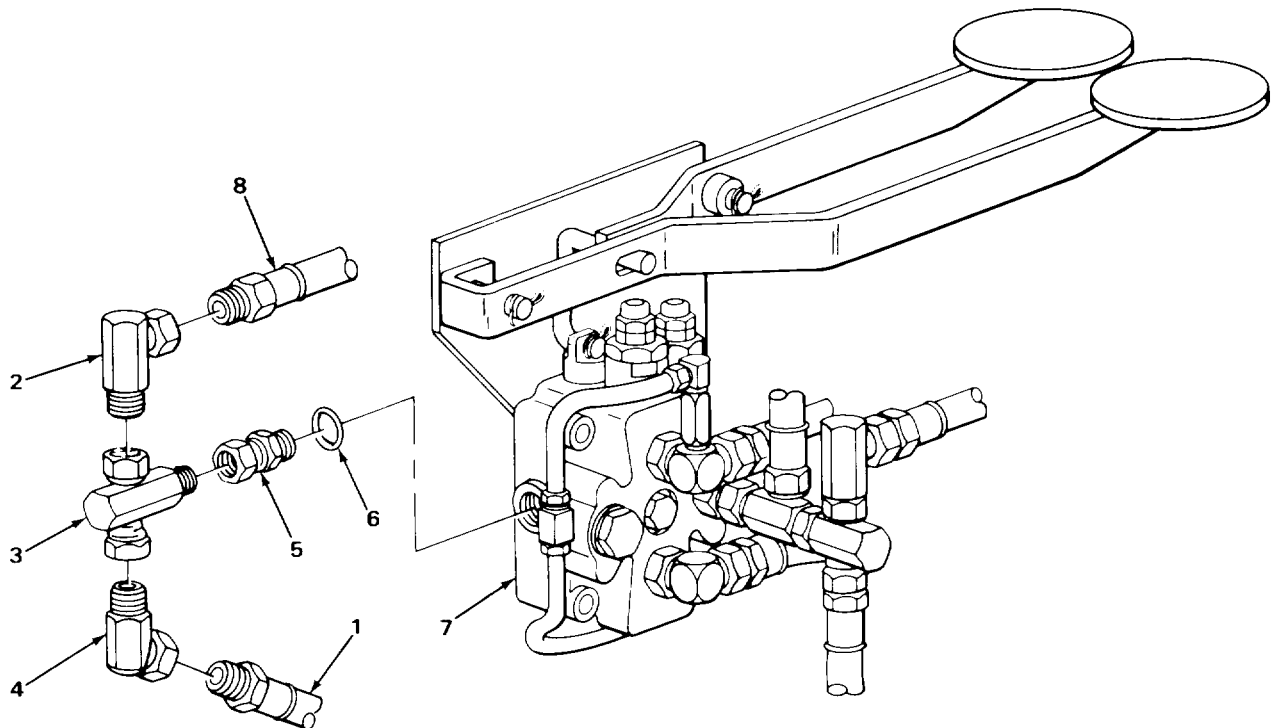

TA243436

JAW DIRECT LINEAR VALVE-TO-HYDRAULIC OIL FILTER RELIEF VALVE OIL LINE (SERIAL NUMBERS 319995 THRU 342573 ONLY) - CONTINUED

LOCATION	ITEM	ACTION REMARKS
INSTALLATION - CONTINUED		
23 Union adapter (1)	New packing (2)	Place in position.
24 Hydraulic oil filter relief valve (3) packing (2)	Union adapter (1) with assembled open-end wrench.	a. Unplug valve (3). b. Screw in and tighten using 1 1/4-inch
25 Union adapter (1)	Hose (4)	a. Take off tag. b. Screw in and tighten using 1 1/8-inch and 1 1/4-inch open-end wrenches.
26 Loader backhoe	Transmission	Check fluid level and add proper amount and grade (TM 5-2420-222-10).
27	Engine	Start and run at high idle (TM 5-2420-222-10).
28	Jaw direct linear valve-to-hydraulic oil filter relief valve oil line	a. Check for leaks. b. If leaking at any connection, tighten using 1 1/8-inch and two 1 1/4-inch open-end wrenches. c. If leaking does not stop, shut down engine (TM 5-2420-222-10) and replace leaking connection packing, fitting, or hose as outlined in this task. d. If found leaking, repeat steps 26 thru 28.
29	Engine	If still running, shut down (TM 5-2420-222-10).

JAW DIRECT LINEAR VALVE-TO-HYDRAULIC OIL FILTER RELIEF VALVE OIL LINE (SERIAL NUMBERS 319995 THRU 342573 ONLY) - CONTINUED

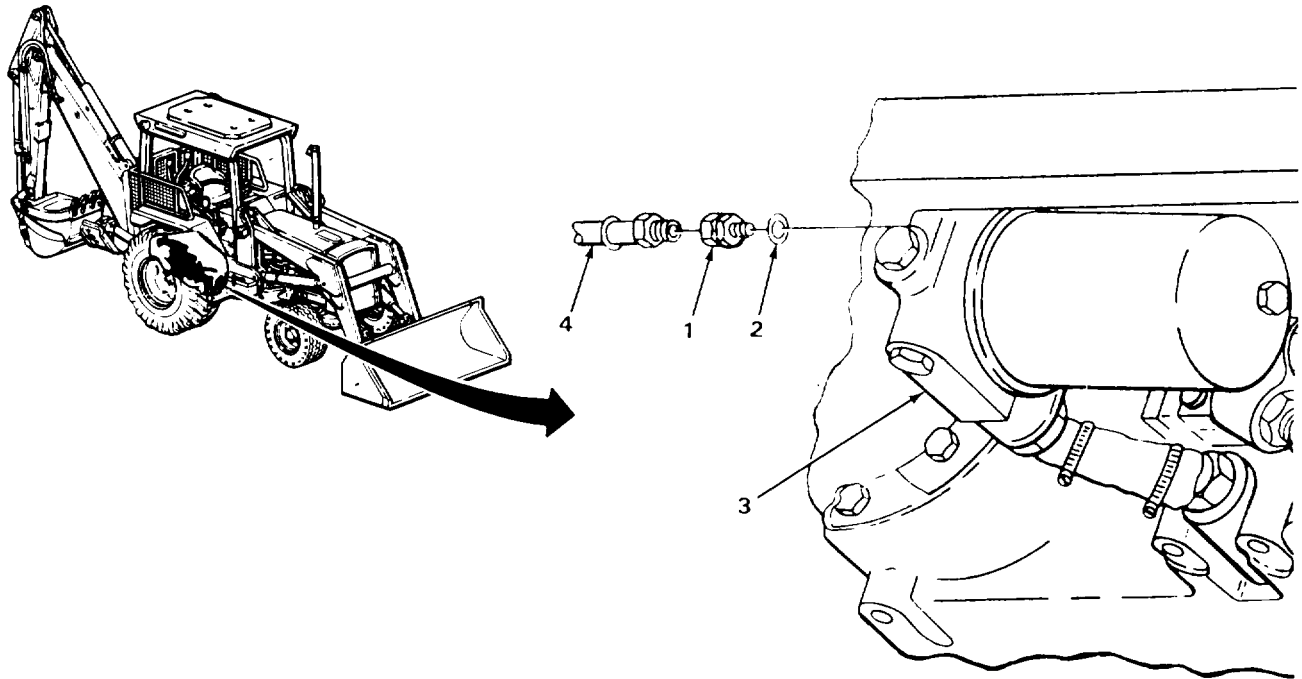

NOTE

FOLLOW-ON MAINTENANCE: Install left rear platform (page 2-1114).

TASK ENDS HERE

QUICK COUPLER-TO-BOOM OIL LINES (SERIAL NUMBERS 235786 THRU 235999 ONLY)

This task covers:

- | | |
|------------------------------|---|
| a. Removal (page 2-1472) | d. Inspection/Replacement (page 2-1475) |
| b. Disassembly (page 2-1474) | e. Assembly (page 2-1475) |
| c. Cleaning (page 2-1474) | f. Installation (page 2-1476) |

INITIAL SETUP

Tools

- Pan, drain
- Pliers, diagonal-cutting
- Pliers, slip-joint
- Vise, machinist's
- Wrench, open-end, 1 1/8-inch
- Wrench, open-end, 1 1/4-inch

Materials/Parts

- Detergent, GP (item 7, Appendix C)
- Rags, wiping (item 21, Appendix C)
- Solvent, drycleaning (item 28, Appendix C)

Materials/Parts - Continued

- Strap, tiedown, electrical (item 29, Appendix C)
- Tags, marking (item 30, Appendix C)
- Tape, lacing and typing (item 33, Appendix C)

Personnel Required

Two

Equipment Condition

Hydraulic system pressure released (page 2-1191)

LOCATION	ITEM	ACTION	REMARKS
----------	------	--------	---------

NOTE

Female quick coupler-to-boom and nipple quick coupler-to-boom oil lines are maintained the same way except as noted. Female quick coupler-to-boom oil line is shown. Repeat procedures as needed for nipple quick coupler-to-boom oil line.

REMOVAL

WARNING

Do not attempt to disconnect hydraulic lines and fittings while engine is running or before hydraulic system pressure has been released. When engine is running, hydraulic system is under pressure. Hydraulic system pressure should be 0 psi (0 kPa) before lines are disconnected. A line or fitting disconnected under pressure will blow off with a lot of force and could cause serious injury to personnel.

Be careful when draining hot fluids. Wear gloves to protect your hands from hot parts and fluids or severe burns could result.

QUICK COUPLER-TO-BOOM OIL LINES (SERIAL NUMBERS 235786 THRU 235999 ONLY) - CONTINUED

LOCATION	ITEM	ACTION REMARKS
1. Hose (1)	Hose (2)	a. Place drain pan underneath. b. Using 1 1/8-inch and 1 1/4-inch open-end wrenches, unscrew and take out. c. Tag (page 2-137). d. Cap (page 2-137).
2. Dipperstick (3) and guard (4)	Hose (1) with assembled parts	a. Attach 5-foot length of lacing and tying tape. b. With aid of assistant, pull through. c. Take off lacing and tying tape, leaving it in place to aid in routing during installation. d. Tag (page 2-137). e. Get rid of drained fluid (page 2-137).

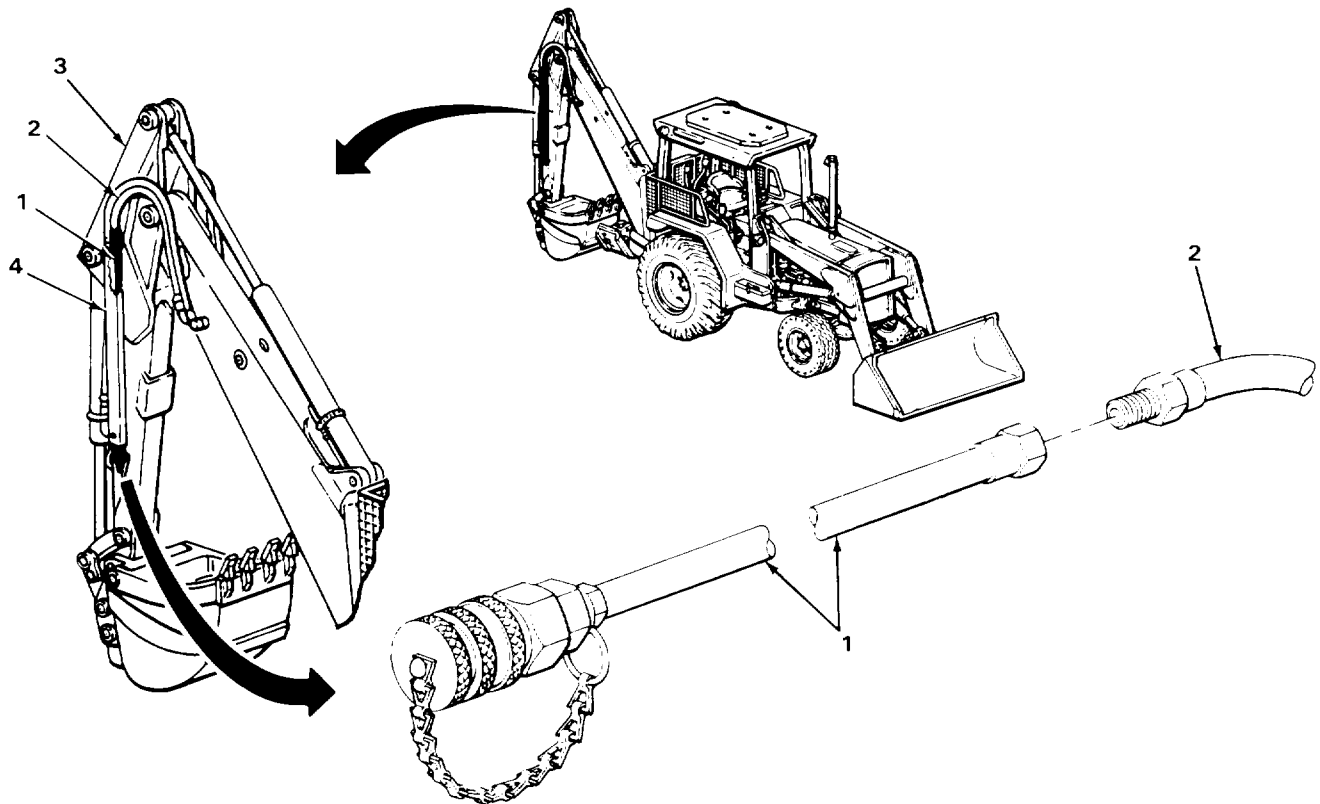

TA243438

QUICK COUPLER-TO-BOOM OIL LINES (SERIAL NUMBERS 235786 THRU 235999 ONLY) - CONTINUED

LOCATION	ITEM	ACTION	REMARKS
DISASSEMBLY			
NOTE			
Female quick coupler is sealed with a plug. Nipple quick coupler is sealed with a cap. Both quick couplers are disassembled the same way.			
3.	Quick coupler (1 or 2)	Plug (3) or cap (4)	Pull out. On female quick couplers, it may be necessary to pull up on locking collar.
4.	Quick coupler (1 or 2) and plug (3) or cap (4)	Electrical tiedown strap (5)	a. Using diagonal-cutting pliers, cut off of chain. b. Get rid of.
5.	Quick coupler (1 or 2)	Hose (6)	a. Place coupler (1 or 2) in machinist's vise. b. Using 1 1/8-inch open-end wrench, unscrew and take out. c. Tag (page 2-137). d. Take coupler (1 or 2) out of machinist's vise.
CLEANING			
NOTE			
For more information on how to clean parts, go to General Maintenance Instructions (page 2-137).			
6	Hose (6) and plug (3) or cap (4)		a. Using clean rags dampened in solution of detergent and water, wipe clean. b. Rinse with clean water. c. Using clean, dry rags, wipe dry.
<u>WARNING</u>			
Drycleaning solvent P-D-680 is toxic and flammable. Wear protective goggles and gloves and use only in a well ventilated area. Avoid contact with skin, eyes, and clothes and don't breathe vapors. Do not use near open flame or excessive heat. The flashpoint is 100°F to 138°F (38° to 59°C). If you become dizzy while using cleaning solvent, get fresh air immediately and get medical aid. If contact with eyes is made, wash your eyes with water and get medical aid immediately.			
7	Quick coupler (1 or 2)		a. Clean in drycleaning solvent. b. Using clean, dry rags, wipe dry.

QUICK COUPLER-TO-BOOM OIL LINES (SERIAL NUMBERS 235786 THRU 235999 ONLY) - CONTINUED

LOCATION	ITEM	ACTION	REMARKS
----------	------	--------	---------

INSPECTION/REPLACEMENT

NOTE

For more information on how to inspect parts, go to General Maintenance Instructions (page 2-137).

Replace defective parts as needed.

8	Hose (6)	Look for cracks, breaks, cuts, and tears.
9	All metal parts	Look for cracks and breaks.
10	Plug (3) or cap (4)	a. Look for damaged packing. If packing is damaged, replace cap or plug. b. Look for missing or broken chain.
11	All threaded parts	Look for damaged threads.

ASSEMBLY

12 Quick coupler (1 or 2)	Hose (6)	a. Place coupler (1 or 2) in machinist's vise. b. Take off tag. c. Screw in and tighten using 1 1/8-inch open-end wrench. d. Take coupler (1 or 2) out of machinist's vise.
---------------------------	----------	--

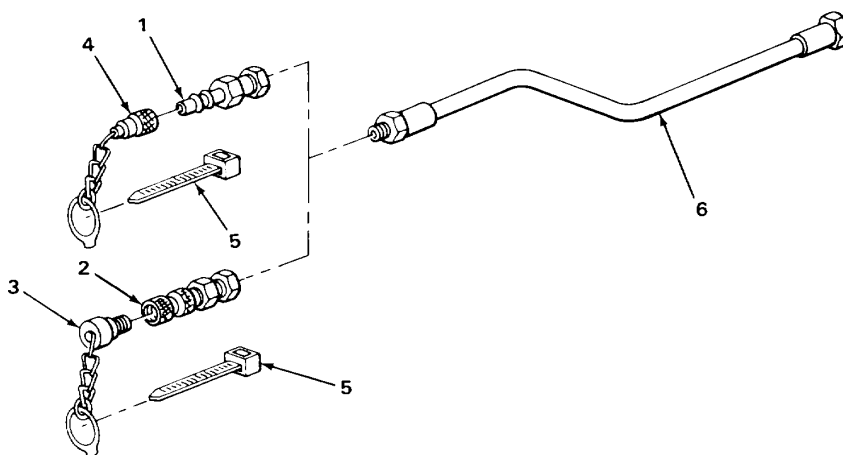

TA243439

QUICK COUPLER-TO-BOOM OIL LINES (SERIAL NUMBERS 235786 THRU 235999 ONLY) - CONTINUED

LOCATION	ITEM	ACTION	REMARKS
ASSEMBLY - CONTINUED			
13	Quick coupler (1 or 2) and plug (3) or cap (4)	New electrical tiedown strap (5)	<ol style="list-style-type: none"> Place in position through end of chain. Using slip-joint pliers, tighten until snug.
14	Quick coupler (1 or 2)	Plug (3) or cap (4)	Snap in. On female quick couplers, it may be necessary to pull locking collar back.
INSTALLATION			
15	Dipperstick (6) and guard (7)	Hose (8) with assembled parts	<ol style="list-style-type: none"> Take off tag. Attach lacing and tying tape. With aid of assistant, pull through. Take off lacing and tying tape.
16	Hose (8)	Hose (9)	<ol style="list-style-type: none"> Take off tag. Uncap. Screw in and tighten using 1 1/8-inch and 1 1/4-inch open-end wrenches.

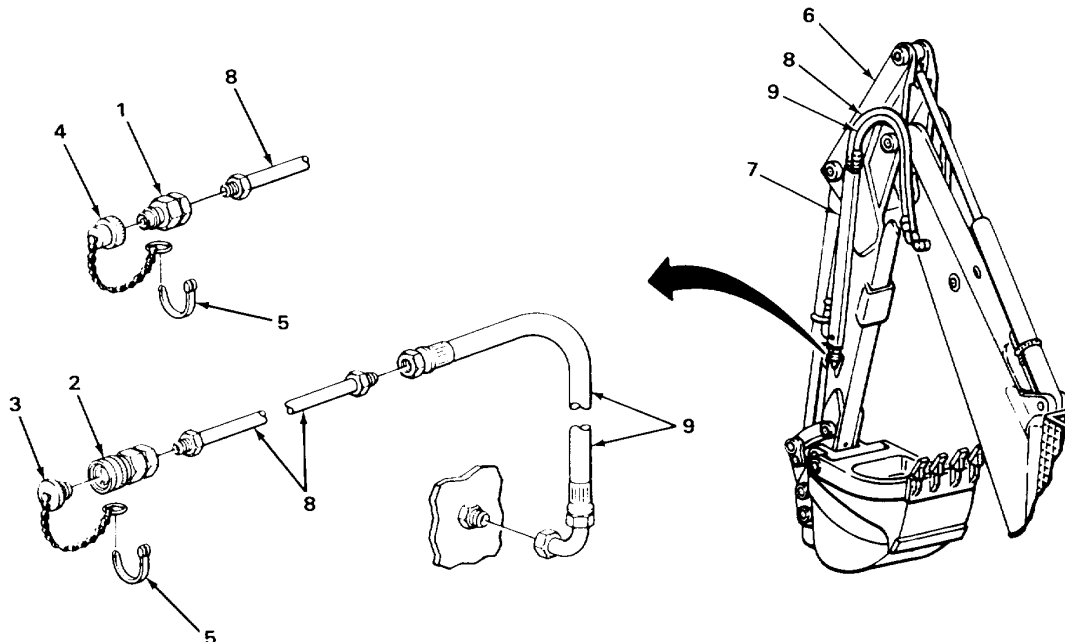

TASK ENDS HERE

TA243440A

QUICK COUPLER-TO-BOOM OIL LINES (SERIAL NUMBERS 319995 THRU 342573 ONLY)

This task covers:

- | | |
|------------------------------|---|
| a. Removal (page 2-1478) | d. Inspection/Replacement (page 2-1480) |
| b. Disassembly (page 2-1478) | e. Assembly (page 2-1481) |
| c. Cleaning (page 2-1479) | f. Installation (page 2-1482) |

INITIAL SETUP

Tools

- Handle, ratchet, 3/8-inch drive
- Pan, drain
- Pliers, diagonal-cutting
- Pliers, slip-joint
- Socket, 3/8-inch drive, 9/16-inch
- Vise, machinist's
- Wrench, open-end, 1 1/8-inch
- Wrench, open-end, 1 1/4-inch (two required)

Materials/Parts

- Detergent, GP (item 7, Appendix C)
- Lockwasher, guard screw (two required)
- Rags, wiping (item 21, Appendix C)

Materials/Parts - Continued

- Solvent, drycleaning (item 28, Appendix C)
- Strap, tiedown, electrical (item 29, Appendix C)
- Tags, marking (item 30, Appendix C)

Personnel Required

One

Equipment Condition

Hydraulic system pressure released (page 2-1191)

LOCATION	ITEM	ACTION	REMARKS
----------	------	--------	---------

NOTE

Female quick coupler-to-boom and nipple quick coupler-to-boom oil lines are maintained the same way except as noted. Female quick coupler-to-boom oil line is shown. Repeat procedures as needed for nipple quick coupler-to-boom oil line.

2-1477

QUICK COUPLER-TO-BOOM OIL LINES (SERIAL NUMBERS 319995 THRU 342573 ONLY) - CONTINUED

LOCATION	ITEM	ACTION	REMARKS
REMOVAL			
<u>WARNING</u>			
Do not attempt to disconnect hydraulic lines and fittings while engine is running or before hydraulic system pressure has been released. When engine is running, hydraulic system is under pressure. Hydraulic system pressure should be 0 psi (0 kPa) before lines are disconnected. A line or fitting disconnected under pressure will blow off with a lot of force and could cause serious injury to personnel.			
Be careful when draining hot fluids. Wear gloves to protect your hands from hot parts and fluids or severe burns could result.			
1.	Tube (1)	Hose (2)	<ul style="list-style-type: none"> a. Place drain pan underneath. b. Using two 1 1/4-inch open-end wrenches, unscrew and take off. c. Tag (page 2-137). d. Cap tube (1) (page 2-137).
2.	Guard (3), two clamps (4), and dipperstick (5)	Two screws (6), washers (7), and lockwashers (8)	<ul style="list-style-type: none"> a. Using 9/16-inch, 3/8-inch drive socket and ratchet handle, unscrew and take out. b. Get rid of lockwashers (8).
3.	Two tubes (9 and 10) and dipperstick (5)	Guard (3) and two clamps (4)	Take off.
4.	Dipperstick (5)	Hose (2) and tube (9) with assembled parts	<ul style="list-style-type: none"> a. Take off. b. Allow fluid to drain into drain pan. c. Get rid of drained fluid (page 2-137).

DISASSEMBLY**NOTE**

Female quick coupler is sealed with a plug. Nipple quick coupler is sealed with a cap. Both quick couplers are disassembled the same way.

5.	Hose (2)	Tube (9)	<ul style="list-style-type: none"> a. Using 1 1/8-inch and 1 1/4-inch open-end wrenches, unscrew and take out. b. Tag (page 2-137).
6.	Quick coupler (11 or 12)	Plug (13) or cap (14)	Pull out. On female quick couplers, it may be necessary to pull up on locking collar.

QUICK COUPLER-TO-BOOM OIL LINES (SERIAL NUMBERS 319995 THRU 342573 ONLY) - CONTINUED

LOCATION	ITEM	ACTION REMARKS
7. Quick coupler (11 or 12) and plug (13) or cap (14)	Electrical tiedown strap (15)	a. Using diagonal-cutting pliers, cut off of chain. b. Get rid of.
8. Quick coupler (11 or 12)	Tube (9)	a. Place coupler (11 or 12) in machinist's vise. b. Using 1 1/8-inch open-end wrench, unscrew and take out. c. Take coupler(11 or 12) out of machinist's vise. d. Tag (page 2-137).

CLEANING

NOTE

For more information on how to clean parts, go to **General Maintenance Instructions (page 2-137)**.

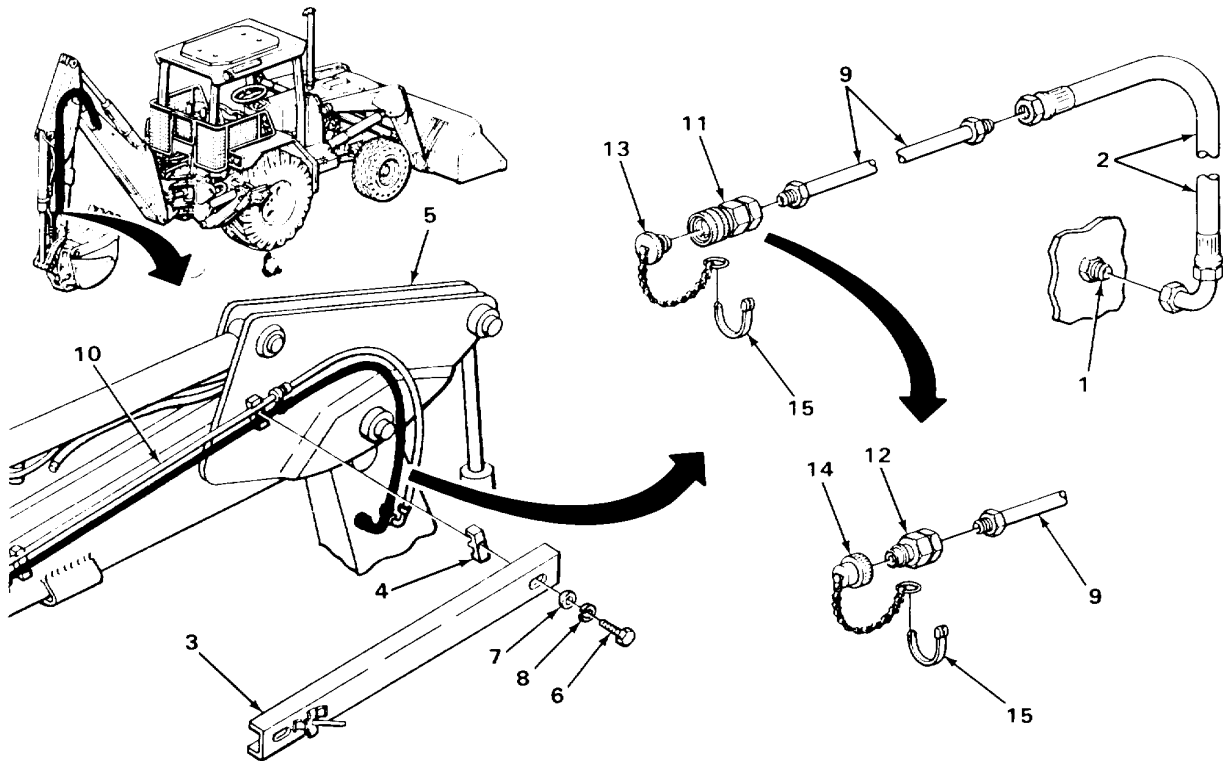

TA243440B

QUICK COUPLER-TO-BOOM OIL LINES (SERIAL NUMBERS 319995 THRU 342573 ONLY) - CONTINUED

LOCATION	ITEM	ACTION	REMARKS
----------	------	--------	---------

CLEANING - CONTINUED

9	All rubber parts	<ul style="list-style-type: none"> a Using clean rags dampened in solution of detergent and water, wipe clean. b. Rinse with clean water. c. Using clean, dry rags, wipe dry. 	
---	------------------	--	--

WARNING

Drycleaning solvent P-D-680 is toxic and flammable. Wear protective goggles and gloves and use only in a well ventilated area. Avoid contact with skin, eyes, and clothes and don't breathe vapors. Do not use near open flame or excessive heat. The flashpoint is 100°F to 138°F (38° to 59°C). If you become dizzy while using cleaning solvent, get fresh air immediately and get medical aid. If contact with eyes is made, wash your eyes with water and get medical aid immediately.

10	All metal parts	<ul style="list-style-type: none"> a. Clean in drycleaning solvent. b. Using clean, dry rags, wipe dry. 	
----	-----------------	---	--

INSPECTION/REPLACEMENT

NOTE

For more information on how to inspect parts, go to General Maintenance Instructions (page 2-137).

Replace defective parts as needed.

11	Hose (1) and two clamps (2)	Look for cracks, breaks, cuts, and tears.	
12	All metal parts	Look for cracks and breaks and abnormal bends.	
13	Plug (3) or cap (4)	<ul style="list-style-type: none"> a Look for damaged packing. If packing is damaged, replace plug or cap. b. Look for missing or broken chain. 	
14	All threaded parts	Look for damaged threads.	

QUICK COUPLER-TO-BOOM OIL LINES (SERIAL NUMBERS 319995 THRU 342573 ONLY) - CONTINUED

LOCATION	ITEM	ACTION	REMARKS
ASSEMBLY			
15 Quick coupler (5 or 6)	Tube (7)	a. Place coupler (5 or 6) in machinist's vise. b. Screw in and tighten using 1 1/8-inch open-end wrench. c. Take coupler (5 or 6) out of machinist's vise. d. Take off tag.	
16 Quick coupler (5 or 6) and plug (3) or cap (4)	New electrical tiedown strap (8)	a. Place in position through end of chain. b. Using slip-joint pliers, tighten until snug.	
17 Quick coupler (5 or 6)	Plug (3) or cap (4)	Snap in. On female quick couplers, it may be necessary to pull locking collar to seat plug.	
18 Hose (1)	Tube (7)	a. Take off tag. b. Screw in and tighten using 1 1/8-inch and 1 1/4-inch open-end wrenches.	

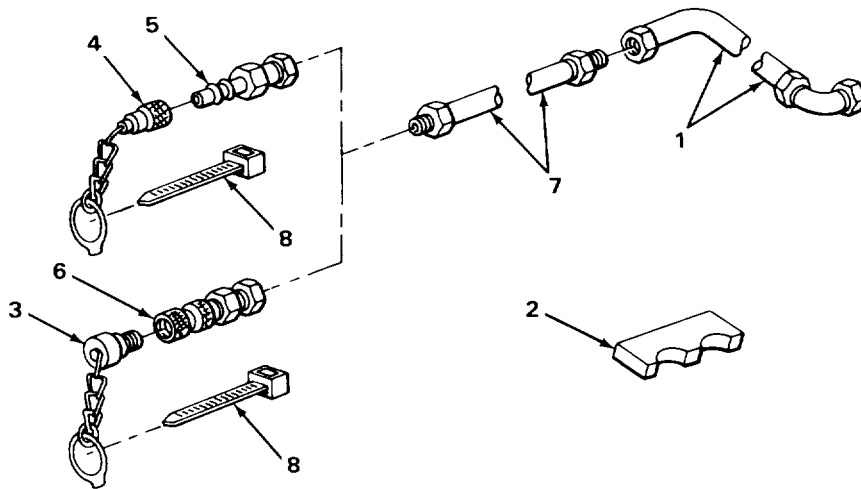

TA243441

QUICK COUPLER-TO-BOOM OIL LINES (SERIAL NUMBERS 319995 THRU 342573 ONLY) - CONTINUED

LOCATION	ITEM	ACTION	REMARKS
INSTALLATION			
19 Dipperstick (1)	Hose (2) and tube (3) with assembled parts	Place in position.	
20 Dipperstick (1) and two tubes (3 and 4)	Two clamps (5)	Place in position.	
21 Dipperstick (1) and two clamps (5)	Guard (6)	Place in position.	
22 Guard (6), two clamps (5), and dipperstick (1)	Two screws (7), washers (8), and new lockwashers (9)	Screw in and tighten using 9/16-inch, 3/8-inch drive socket and ratchet handle.	
23. Tube (10)	Hose (2)	a. Uncap tube(10). b. Take off tag. c. Screw on and tighten using two 1 1/4-inch open-end wrenches.	

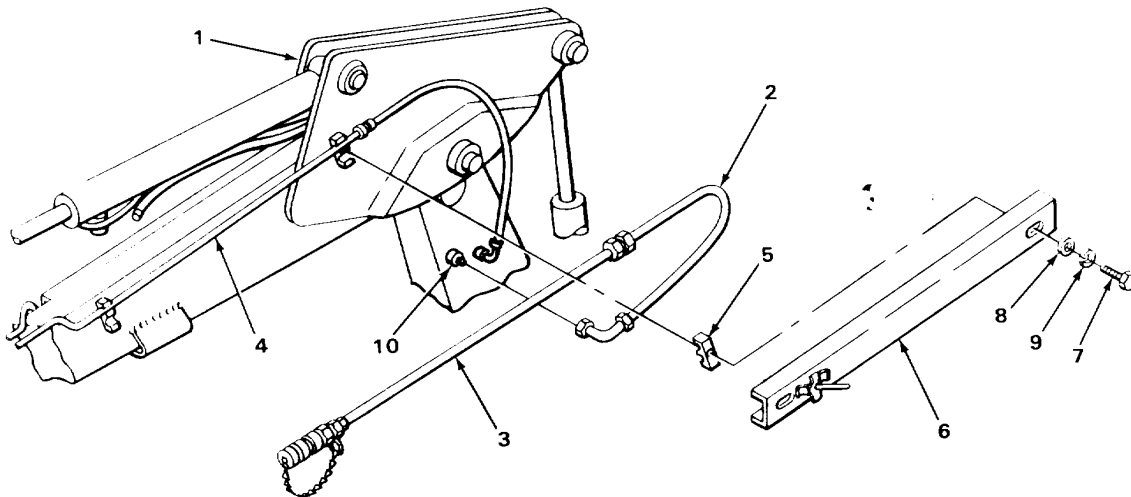

TASK ENDS HERE

TA243442

BOOM-TO-MANIFOLD HYDRAULIC IMPACTOR RETURN OIL LINE (SERIAL NUMBERS 235786 THRU 235999 ONLY)

This task covers:

- | | |
|---------------------------|---|
| a. Removal (page 2-1484) | c. Inspection/Replacement (page 2-1486) |
| b. Cleaning (page 2-1486) | d. Installation (page 2-1486) |
-

INITIAL SETUP:

Tools

Handle, ratchet, 1/2-inch drive
 Knife, pocket
 Pan, drain
 Socket, 1/2-inch drive, 9/16-inch
 Wrench, box, 9/16-inch
 Wrench, open-end, 1 1/8-inch
 Wrench, open-end, 1 1/4-inch

Materials/Parts

Detergent, GP (item 7, Appendix C)
 Nut, special, clamp screw
 Packing, union adapter

Materials/Parts - Continued

Rags, wiping (item 21, Appendix C)
 Solvent, drycleaning (item 28, Appendix C)
 Tags, marking (item 30, Appendix C)
 Tape, lacing and tying (item 33,
 (Appendix C)

Personnel Required

Two

Equipment Condition

Hydraulic system pressure released
 (page 2-1191)

2-1483

BOOM-TO-MANIFOLD HYDRAULIC IMPACTOR RETURN OIL LINE (SERIAL NUMBERS 235786 THRU 235999 ONLY) - CONTINUED

LOCATION	ITEM	ACTION	REMARKS
REMOVAL			
<u>WARNING</u>			
<p>Do not attempt to disconnect hydraulic lines and fittings while engine is running or before hydraulic system pressure has been released. When engine is running, hydraulic system is under pressure. Hydraulic system pressure should be 0 psi (0 kPa) before lines are disconnected. A line or fitting disconnected under pressure will blow off with a lot of force and could cause serious injury to personnel.</p>			
<p>Be careful when draining hot fluids. Wear gloves to protect your hands from hot parts and fluids or severe burns could result.</p>			
1.Union adapter (1)	Hose (2)	a. Place drain pan underneath. b. Using 1 1/8-inch and 1 1/4-inch open-end wrenches, unscrew and take out. c. Tag (page 2-137).	
2.Manifold (3)	Union adapter (1) with assembled packing (4)	a. Using 1 1/4-inch open-end wrench, unscrew and take out. b. Plug manifold (3) (page 2-137).	
3.Union adapter (1)	Packing (4)	a. Using pocket knife, take off. b. Get rid of.	
4.Clamp (5) and manifold block (6)	Screw (7) and special nut (8)	a. Using 9/16-inch, 1/2-inch drive socket, ratchet handle, and 9/16-inch box wrench, unscrew and take apart. b. Get rid of special nut (8).	
5.Hose (2), isolator (9), and manifold block (6)	Clamp (5)	Take off.	
6.Manifold block (6)	Hose (2)	Take off.	
7.Hose (10)	Hose (2)	a. Place drain pan underneath. b. Using 1 1/8-inch and 1 1/4-inch open-end wrenches, unscrew and take out. c. Plug hose (10) (page 2-137). d. Tag hose (10) (page 2-137). e. Get rid of drained fluid (page 2-137).	

BOOM-TO-MANIFOLD HYDRAULIC IMPACTOR RETURN OIL LINE (SERIAL NUMBERS 235786 THRU 235999 ONLY) - CONTINUED

LOCATION	ITEM	ACTION	REMARKS
8.Guard (11) and boom (12)	Hose (2)	a. Attach 5-foot length of lacing and tying tape. b. With aid of assistant, pull out. c. Take off lacing and tying tape, leaving it in position to aid in routing during installation.	

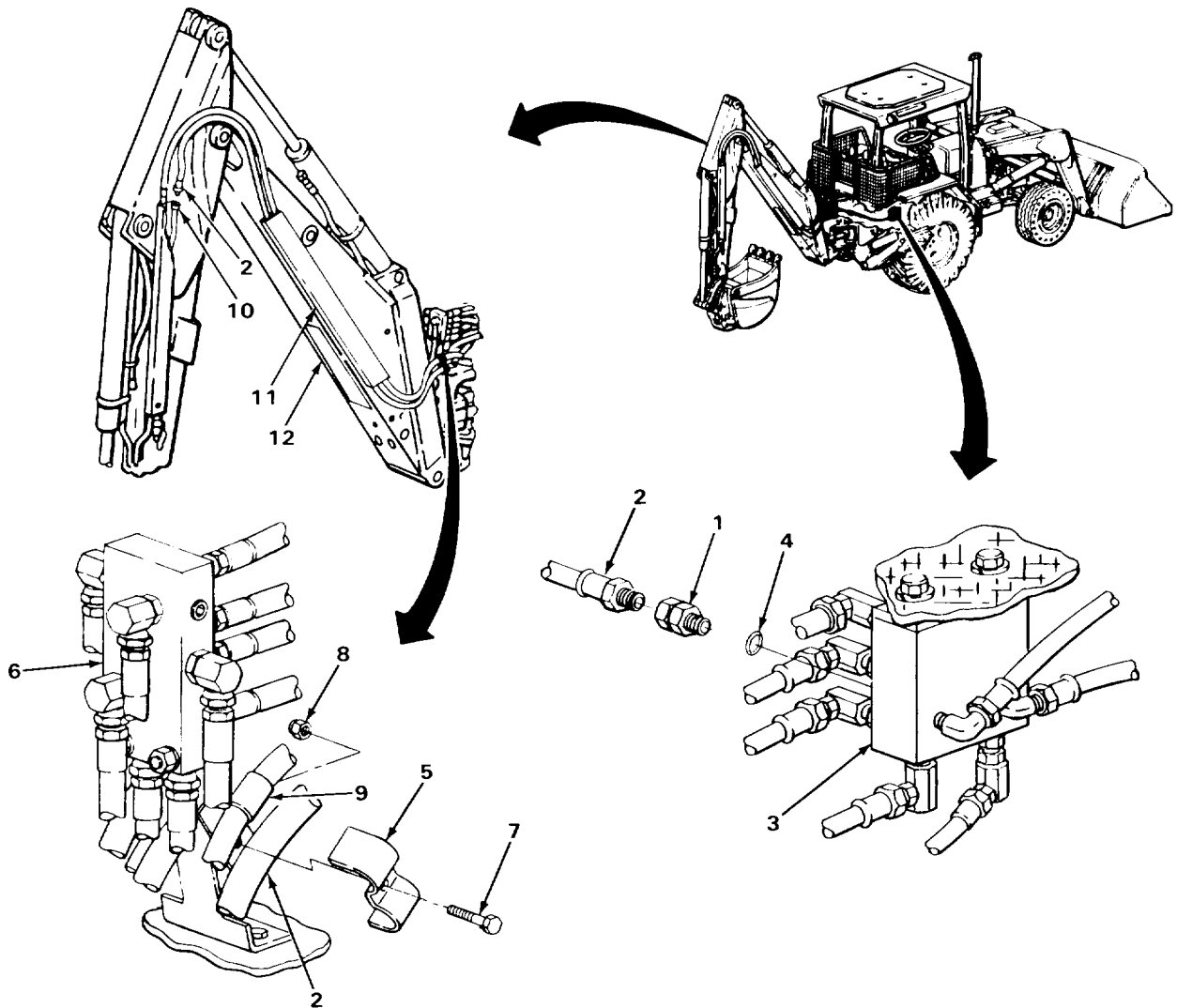

BOOM-TO-MANIFOLD HYDRAULIC IMPACTOR RETURN OIL LINE (SERIAL NUMBERS 235786 THRU 235999 ONLY) - CONTINUED

LOCATION	ITEM	ACTION	REMARKS
----------	------	--------	---------

CLEANING

NOTE

For more information on how to clean parts, go to **General Maintenance Instructions (page 2-137)**.

- | | | |
|----|----------|---|
| 9. | Hose (1) | a. Using clean rags dampened in solution of detergent and water, wipe clean.
b. Rinse with clean water.
c. Using clean, dry rags, wipe dry. |
|----|----------|---|

WARNING

Drycleaning solvent P-D-680 is toxic and flammable. Wear protective goggles and gloves and use only in a well ventilated area. Avoid contact with skin, eyes, and clothes and don't breathe vapors. Do not use near open flame or excessive heat. The flashpoint is 100°F to 138°F (38° to 59°C). If you become dizzy while using cleaning solvent, get fresh air immediately and get medical aid. If contact with eyes is made, wash your eyes with water and get medical aid immediately.

- | | | |
|-----|-----------------|---|
| 10. | All metal parts | a. Clean in drycleaning solvent.
b. Using clean, dry rags, wipe dry. |
|-----|-----------------|---|

INSPECTION/REPLACEMENT

NOTE

For more information on how to inspect parts, go to **General Maintenance Instructions (page 2-137)**.

Replace defective parts as needed.

- | | | |
|-----|--------------------|--|
| 11. | Hose (1) | Look for cracks, breaks, cuts, and tears. |
| 12. | All metal parts | Look for cracks, breaks, and abnormal bends. |
| 13. | All threaded parts | Look for damaged threads. |

INSTALLATION

- | | | |
|----------------------------|----------|---|
| 14. Guard (2) and boom (3) | Hose (1) | a. Attach lacing and tying tape.
b. With aid of assistant, pull into position.
c. Take off lacing and tying tape. |
|----------------------------|----------|---|

**BOOM TO-MANIFOLD HYDRAULIC IMPACTOR RETURN OIL LINE (SERIAL NUMBERS 235786 THRU235999 ONLY)
- CONTINUED**

LOCATION	ITEM	ACTION REMARKS
15.Hose (4)	Hose (1) b. c.	a. Take tag off hose (4). Unplug hose (4). Screw in and tighten using 1 11/8-inch and 1 1/4-inch open-end wrenches.
16.Manifold block (5)	Hose (1)	Place in position.
17.Hose (1), isolator (6), and manifold block (5)	Clamp (7)	Place in position.
18.Clamp (7) and manifold block (5)	Screw (8) and special nut (9)	Screw together and tighten using 9/16-inch, 1/2-inch drive socket, ratchet handle, and 9/16-inch box wrench.

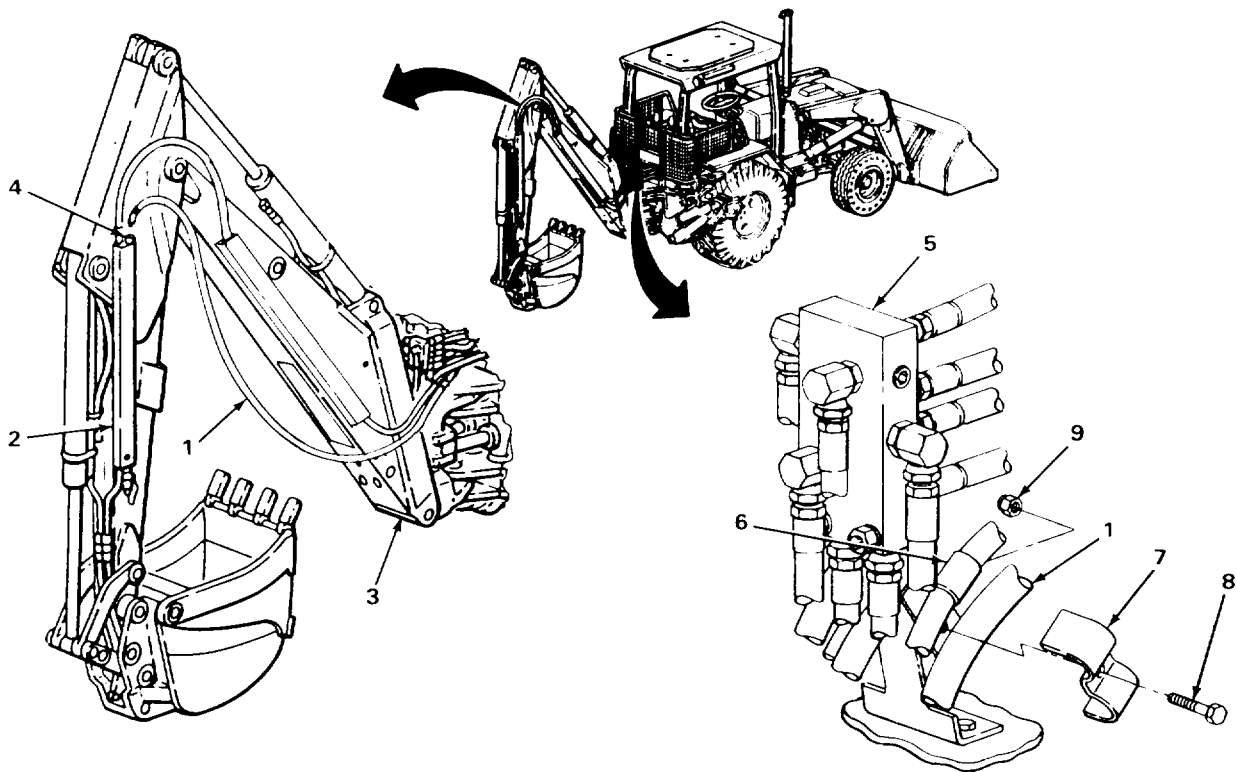

BOOM-TO-MANIFOLD HYDRAULIC IMPACTOR RETURN OIL LINE (SERIAL NUMBERS 235786 THRU 235999 ONLY) - CONTINUED

LOCATION	ITEM	ACTION	REMARKS
INSTALLATION - CONTINUED			
19.Union adapter (1)	New packing (2)	Place in position.	
20.Manifold (3)	Union adapter (1) with assembled packing (2)	a. Unplug manifold (3). b. Screw in and tighten using 1 1/4-inch open-end wrench.	
21.Union adapter (1)	Hose (4)	a. Take off tag. b. Screw in and tighten using 1 1/8-inch and 1 1/4-inch open-end wrenches.	

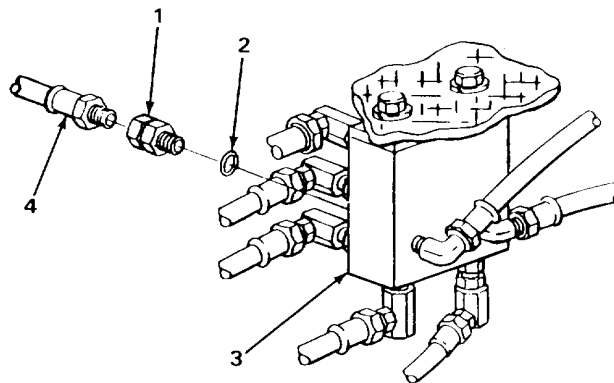
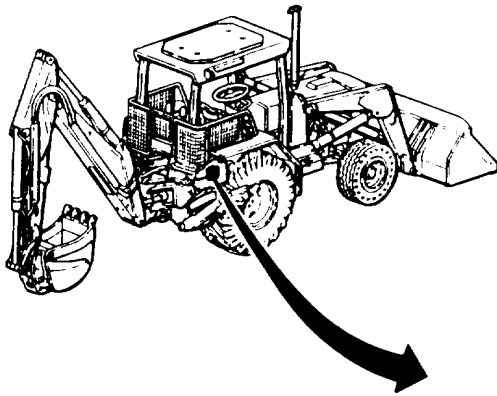

TASK ENDS HERE

BOOM-TO-BACKHOE CONTROL VALVE HYDRAULIC IMPACTOR RETURN OIL LINE (SERIAL NUMBERS 319995 THRU 342573 ONLY)

This task covers:

- | | |
|------------------------------|---|
| a. Removal (page 2-1489) | d. Inspection/Replacement (page 2-1494) |
| b. Disassembly (page 2-1492) | e. Assembly (page 2-1495) |
| c. Cleaning (page 2-1494) | f. Installation (page 2-1496) |

INITIAL SETUP:

Tools

- Handle, ratchet, 3/8-inch drive
- Knife, pocket
- Pan, drain
- Pliers, diagonal-cutting
- Pliers, slip-joint
- Socket, 3/8-inch drive, 9/16-inch
- Vise, machinist's
- Wrench, box, 9/16-inch
- Wrench, box, 1 1/4-inch
- Wrench, open-end, 9/16-inch
- Wrench, open-end, 1 1/8-inch
- Wrench, open-end, 1 1/4-inch (two required)
- Wrench, open-end, 1 3/8-inch

Materials/Parts

- Band (as required)

Materials/Parts - Continued

- Detergent, GP (item 7, Appendix C)
- Nut, special (two required)
- Packing, adapter
- Packing, union adapter
- Rags, wiping (item 21, Appendix C)
- Solvent, drycleaning (item 28, Appendix C)
- Tags, marking (item 30, Appendix C)

Personnel Required

One

Equipment Condition

Backhoe valve box cover removed (page 2-1157)

LOCATION	ITEM	ACTION REMARKS
REMOVAL		
1.Loader backhoe	Boom, dipperstick, and bucket	a. Extend as far as possible (TM 5-2420-222-10). b. Lower to ground so that boom and dipperstick are horizontal (TM 5-2420-222-10).
2.	Hydraulic system	Release pressure (page 2-1191).

BOOM-TO-BACKHOE CONTROL VALVE HYDRAULIC IMPACTOR RETURN OIL LINE (SERIAL NUMBERS 319995 THRU 342573 ONLY) - CONTINUED

LOCATION	ITEM	ACTION	REMARKS
REMOVAL - CONTINUED			
<u>WARNING</u>			
<p>Do not attempt to disconnect hydraulic lines and fittings while engine is running or before hydraulic system pressure has been released. When engine is running, hydraulic system is under pressure. Hydraulic system pressure should be 0 psi (0 kPa) before lines are disconnected. A line or fitting disconnected under pressure will blow off with a lot of force and could cause serious injury to personnel.</p>			
<p>Be careful when draining hot fluids. Wear gloves to protect your hands from hot parts and fluids or severe burns could result.</p>			
3.Adapter (1)	Hose (2)	a. Place drain pan underneath. b. Using 1 1/8-inch and 1 1/4-inch open-end wrenches, unscrew and take out. c. Cap (page 2-137). d. Tag (page 2-137).	
4.Adapter (3)	Hose (4)	a. Using 1 1/8-inch and 1 1/4-inch open-end wrenches, unscrew and take out. b. Tag (page 2-137).	
5.Union adapter (5)	Adapter (1) with assembled parts	a. Note relative position for proper placement during installation. b. Using 1 1/4-inch and 1 3/8-inch open-end wrenches, unscrew and take out.	
6.Backhoe control valve (6)	Union adapter (5) with assembled packing (7)	a. Using 1 11/16-inch box wrench, unscrew and take out. b. Plug valve (6) (page 2-137).	
7.Union adapter (5)	Packing (7)	a. Using pocket knife, take off. b. Get rid of.	
8.Bracket (8) and clamp (9)	Screw (10) and special nut (11)	a. Using 9/16-inch, 3/8-inch drive socket, ratchet handle, and 9/16-inch box wrench, unscrew and take apart. b. Get rid of special nut (11).	
9.Bracket (8), isolator (12), and hose (4)	Clamp (9)	Take off.	

BOOM-TO-BACKHOE CONTROL VALVE HYDRAULIC IMPACTOR RETURN OIL LINE (SERIAL NUMBERS 319995 THRU 342573 ONLY) - CONTINUED

LOCATION	ITEM	ACTION	REMARKS
----------	------	--------	---------

10.Bracket (8)	Hose (4)	Take off.	
----------------	----------	-----------	--

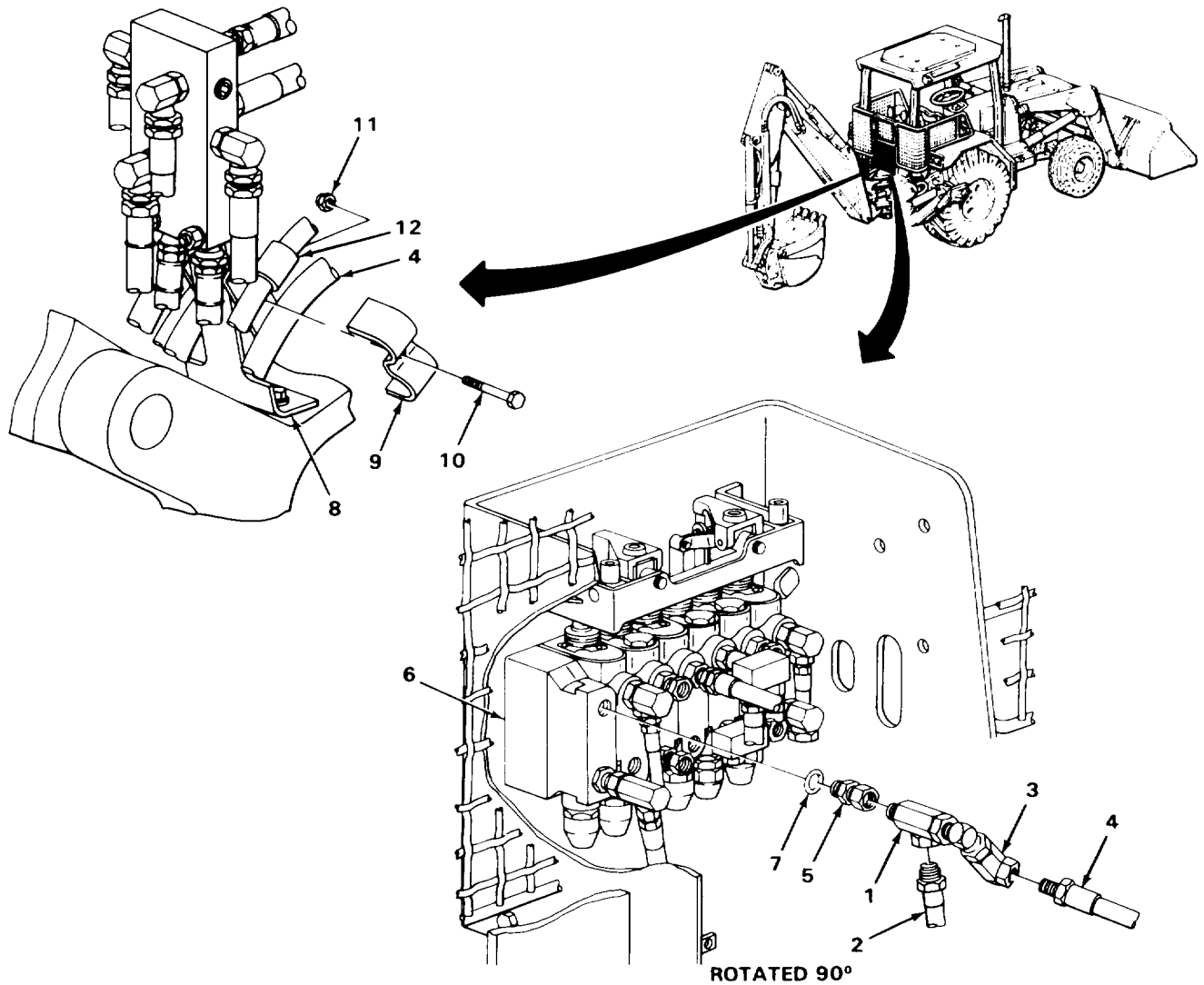

BOOM-TO-BACKHOE CONTROL VALVE HYDRAULIC IMPACTOR RETURN OIL LINE (SERIAL NUMBERS 319995 THRU 342573 ONLY) - CONTINUED

LOCATION	ITEM	ACTION REMARKS
REMOVAL - CONTINUED		
11.Boom (1) and clamp (2)	Screw (3) and special nut (4)	a. Using 9/16-inch, 3/8-inch drive socket, ratchet handle, and 9/16-inch open-end wrench, unscrew and take off. b. Get rid of special nut (4).
12.Boom (1) and tube (5)	Clamp (2)	Take off.
13.Nine hoses (6 thru 14)	Bands (15)	a. Note location and quantity for proper placement during installation. b. Using diagonal-cutting pliers, cut off. c. Get rid of.
14.Tube (5)	Hose (6)	a. Place drain pan underneath. b. Using 1 1/8-inch and 1 1/4-inch open-end wrenches, unscrew and take out. c. Tag (page 2-137).
15.	Hose (16)	a. Place drain pan underneath. b. Using 1 1/4-inch open-end wrench, unscrew and take off. c. Plug (page 2-137). d. Tag (page 2-137). e. Get rid of drained fluid (page 2-137).
16.Boom (1) and tube (5)	Jamnut (17)	Using 1 1/4-inch open-end wrench, unscrew and take off.
17.Boom (1)	Tube (5)	a. Take out. b. Tag (page 2-137).
DISASSEMBLY		
18.Adapter (18) and adapter (19)	Nut (20)	a. Place adapter (18) in machinist's vise. b. Using 1 1/8-inch and 1 1/4-inch open-end wrenches, loosen.

BOOM-TO-BACKHOE CONTROL VALVE HYDRAULIC IMPACTOR RETURN OIL LINE (SERIAL NUMBERS 319995 THRU 342573 ONLY) - CONTINUED

LOCATION	ITEM	ACTION	REMARKS
19.Adapter (18)	Adapter (19) with assembled parts	a. Note relative position for proper placement during assembly. b. Using 1 1/8-inch open-end wrench, unscrew and take out. c. Take adapter (18) out of machinist's vise.	
20.Adapter (19)	Packing (21)	a. Using pocket knife, take off. b. Get rid of.	
21.Adapter (19)	Adapter (22)	a. Place adapter (19) in machinist's vise. b. Note relative position for proper placement during assembly. c. Using two 1 1/4-inch open-end wrenches, unscrew and take out. d. Take adapter (19) out of machinist's vise.	

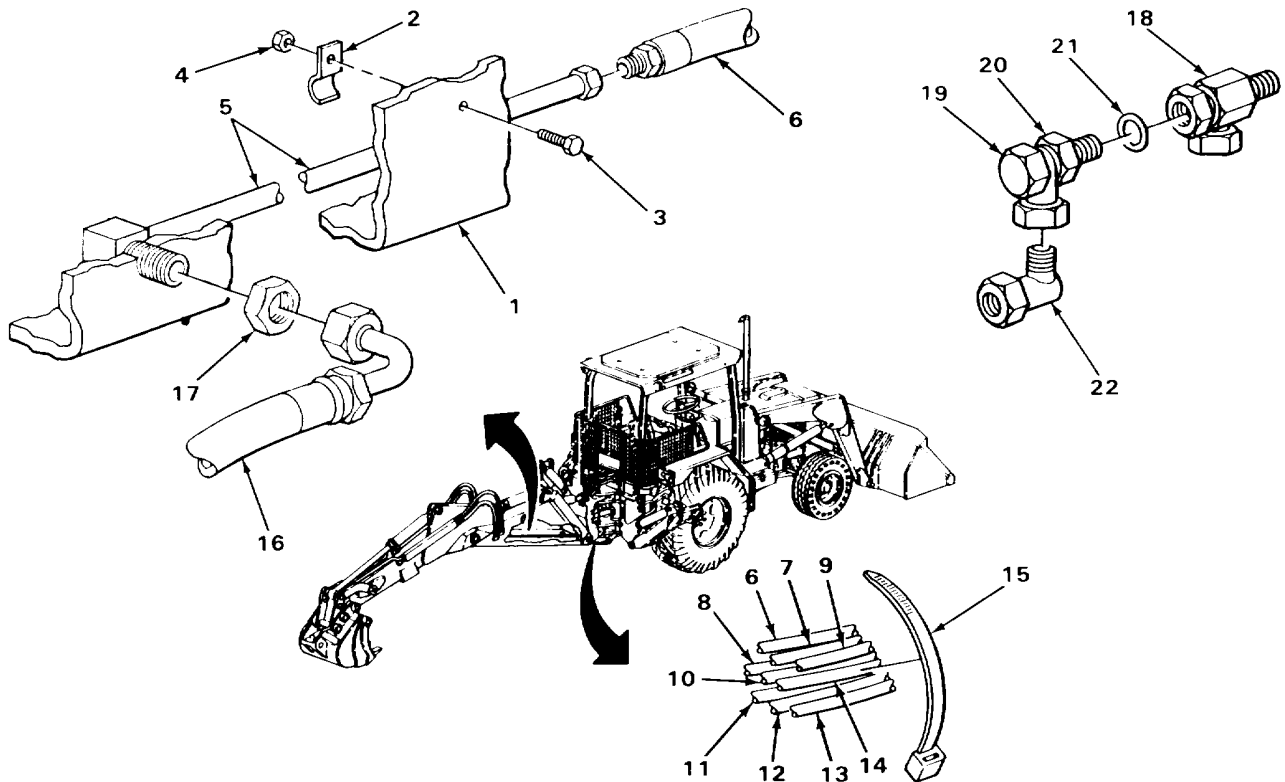

TA243446

BOOM-TO-BACKHOE CONTROL VALVE HYDRAULIC IMPACTOR RETURN OIL LINE (SERIAL NUMBERS 319995 THRU 342573 ONLY) - CONTINUED

LOCATION	ITEM	ACTION	REMARKS
CLEANING			
NOTE			
For more information on how to clean parts, go to General Maintenance Instructions (page 2-137).			
22.	Hose (1)	a. Using clean rags dampened in solution of detergent and water, wipe clean. b. Rinse with clean water. c. Using clean, dry rags, wipe dry.	
<u>WARNING</u>			
Drycleaning solvent P-D-680 is toxic and flammable. Wear protective goggles and gloves and use only in a well ventilated area. Avoid contact with skin, eyes, and clothes and don't breathe vapors. Do not use near open flame or excessive heat. The flashpoint is 100°F to 138°F (38° to 59°C). If you become dizzy while using cleaning solvent, get fresh air immediately and get medical aid. If contact with eyes is made, wash your eyes with water and get medical aid immediately.			
23.	All metal parts	a. Clean in drycleaning solvent. b. Using clean, dry rags, wipe dry.	
INSPECTION/REPLACEMENT			
NOTE			
For more information on how to inspect parts, go to General Maintenance Instructions (page 2-137).			
Replace defective parts as needed.			
24.	Hose (1)	Look for cracks, breaks, cuts, and tears.	
25.	All metal parts	Look for cracks and breaks and abnormal bends.	
26.	All threaded parts	Look for damaged threads.	

BOOM-TO-BACKHOE CONTROL VALVE HYDRAULIC IMPACTOR RETURN OIL LINE (SERIAL NUMBERS 319995 THRU 342573 ONLY) - CONTINUED

LOCATION	ITEM	ACTION REMARKS
ASSEMBLY		
27.Adapter (2)	Adapter (3)	<ul style="list-style-type: none"> a. Place adapter (2) in machinist's vise. b. Screw in and tighten to same relative position noted during disassembly using two 1 1/4-inch open-end wrenches. c. Take adapter (2) out of machinist's vise.
28.	Nut (4)	Screw on all the way.
29.	New packing (5)	Place in position.
30.Adapter (6)	Adapter (2) with assembled parts	<ul style="list-style-type: none"> a. Place adapter (2) in machinist's vise. b. Screw in and tighten to same relative position noted during disassembly using 1 1/8-inch open-end wrench.
31.Adapter (2) and adapter (6)	Nut (4)	<ul style="list-style-type: none"> a. Using 1 1/8-inch and 1 1/4-inch open-end wrenches, tighten until seated against adapter (6). b. Take adapter (6) out of machinist's vise.

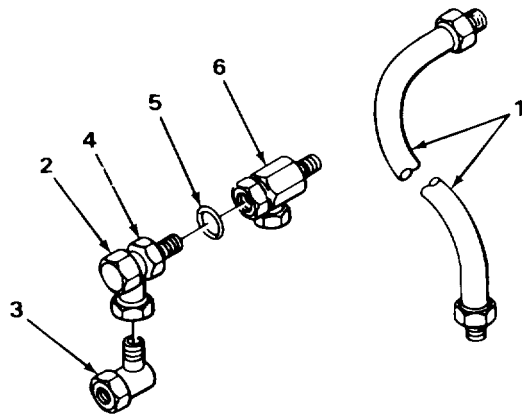

BOOM-TO-BACKHOE CONTROL VALVE HYDRAULIC IMPACTOR RETURN OIL LINE (SERIAL NUMBERS 319995 THRU 342573 ONLY) - CONTINUED

LOCATION	ITEM	ACTION REMARKS
INSTALLATION		
32.Boom (1)	Tube (2)	a. Takeoff tag. b. Place in position.
33.Boom (1) and tube (2)	Jamnut (3)	Screw in and tighten using 1 1/4-inch open-end wrench.
34.Tube(2)	Hose(4)	a. Unplug. b. Take off tag. c. Screw on and tighten using 1 1/4-inch open-end wrench.
35.	Hose (5)	a. Take off tag. b. Screw on and tighten using 1 1/8-inch and 1 1/4 inch open-end wrenches.
36.Nine hoses (5 thru 13)	New bands (14)	a. Place same quantity in relative positions noted during removal. b. Using slip-joint pliers, tighten until snug.
37.Boom (1) and tube (2)	Clamp (15)	Place in position.
38.Boom (1) and clamp (15)	Screw (16) and new special nut (17)	Screw together and tighten using 9/16-inch, 3/8-inch drive socket, ratchet handle, and 9/16-inch open-end wrench.
39.Bracket (18)	Hose (5)	Place in position.
40.Bracket (18), isolator (19), and hose (5)	Clamp (20)	Place in position.
41.Bracket (18) and clamp (20)	Screw (21) and new special nut (22)	Screw together and tighten using 9/16-inch, 3/8-inch drive socket, ratchet handle, and 9/16-inch box wrench.
42.Union adapter (23)	New packing (24)	Place in position.

BOOM-TO-BACKHOE CONTROL VALVE HYDRAULIC IMPACTOR RETURN OIL LINE (SERIAL NUMBERS 319995 THRU 342573 ONLY) - CONTINUED

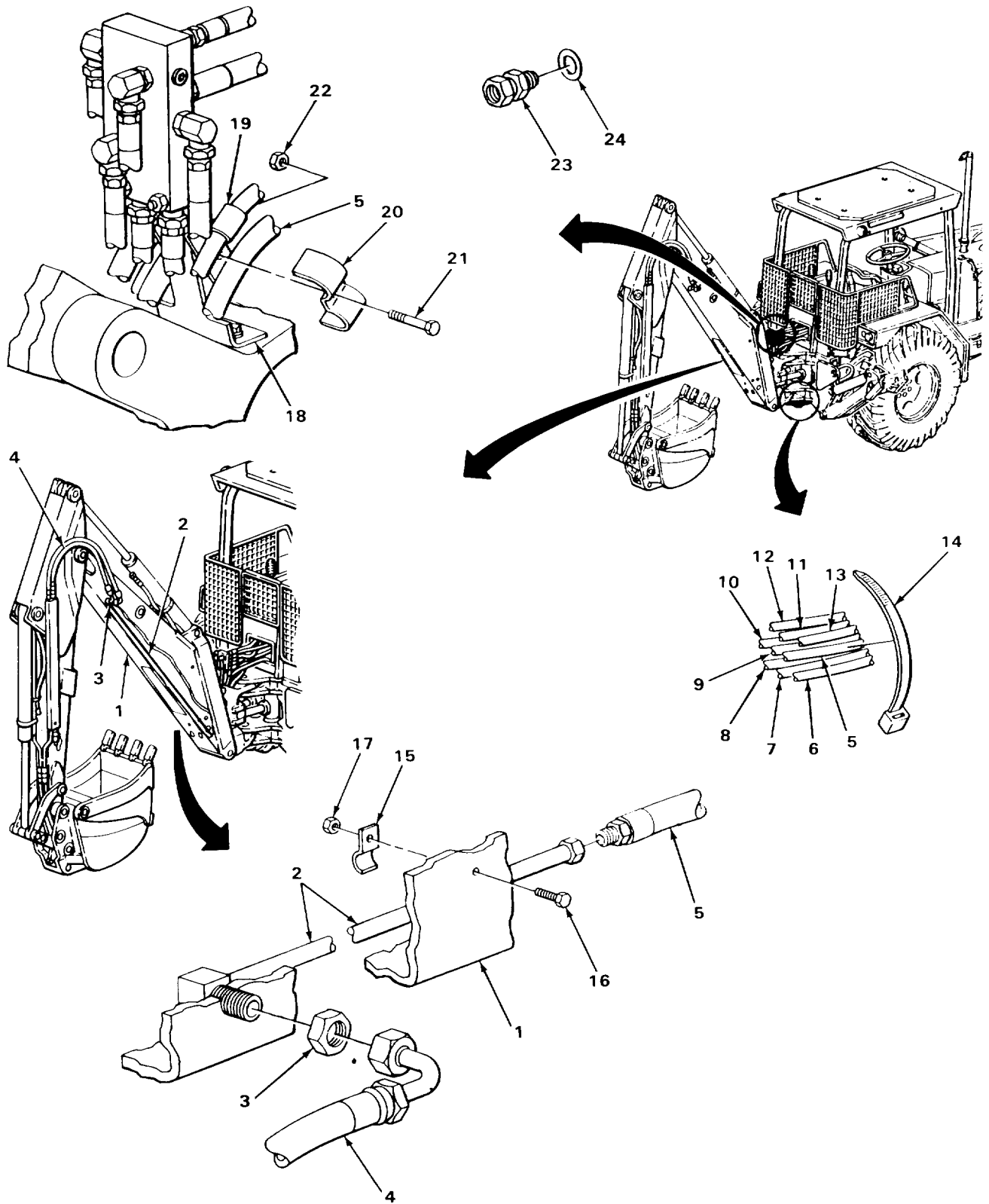

BOOM-TO-BACKHOE CONTROL VALVE HYDRAULIC IMPACTOR RETURN OIL LINE (SERIAL NUMBERS 319995 THRU 342573 ONLY) - CONTINUED

LOCATION	ITEM	ACTION	REMARKS
INSTALLATION - CONTINUED			
43.Backhoe control valve (1)	Union adapter (2) with assembled packing (3)	a. Unplug valve (1). b. Screw in and tighten using 1 1/4-inch box wrench.	
44.Union adapter (2)	Adapter (4) with assembled parts	Screw in and tighten to same relative position noted during removal using 1 1/4-inch and 1 3/8-inch open-end wrenches.	
45.Adapter (4)	Hose (5)	a. Take off tag. b. Uncap. c. Screw in and tighten using 1 1/8-inch and 1 1/4-inch open-end wrenches.	
46.Adapter (6)	Hose (7)	a. Take off tag. b. Screw in and tighten using 1 1/8-inch and 1 1/4-inch open-end wrenches.	

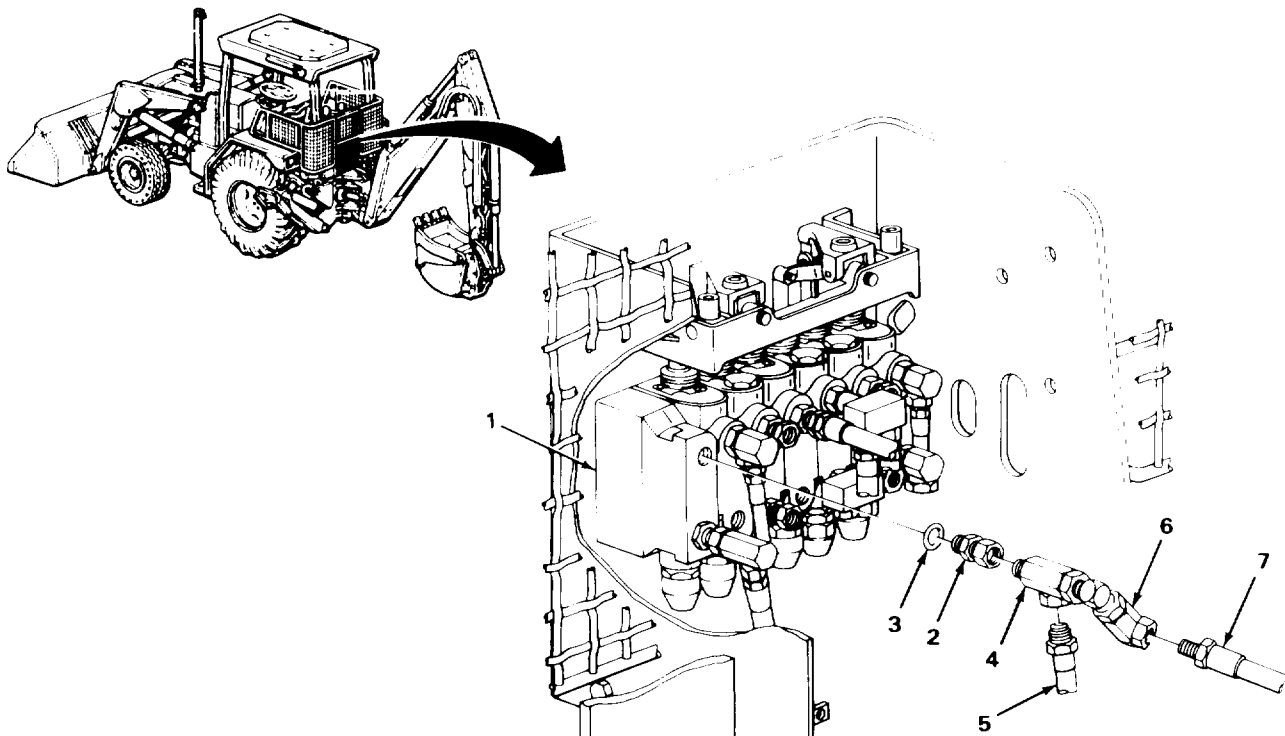

TA243449

BOOM-TO-BACKHOE CONTROL VALVE HYDRAULIC IMPACTOR RETURN OIL LINE (SERIAL NUMBERS 319995 THRU 342573 ONLY) - CONTINUED

NOTE

FOLLOW-ON MAINTENANCE: Install backhoe valve box cover (page 2-1157).

TASK ENDS HERE

HYDRAULIC IMPACTOR FLOW REGULATOR-TO-BOOM OIL LINE (SERIAL NUMBERS 235786 THRU 235999 ONLY)

This task covers:

- | | |
|---|--|
| <ul style="list-style-type: none"> a. Removal (page 2-1500) b. Cleaning (page 2-1502) | <ul style="list-style-type: none"> c. Inspection/Replacement (page 2-1502) d. Installation (page 2-1502) |
|---|--|

INITIAL SETUP:

Tools

- Handle, ratchet, 1/2-inch drive
- Pan, drain
- Socket, 1/2-inch drive, 9/16-inch
- Wrench, box, 9/16-inch
- Wrench, open-end, 1 1/8-inch
- Wrench, open-end, 1 1/4-inch
- Wrench, open-end, 1 3/8-inch

Materials/Parts

- Detergent, GP (item 7, Appendix C)
- Nut, special, clamp screw

Materials/Parts - Continued

- Rags, wiping (item 21, Appendix C)
- Solvent, drycleaning (item 28, Appendix C)
- Tags, marking (item 30, Appendix C)
- Tape, lacing and tying (item 33, Appendix C)

Personnel Required

Two

Equipment Condition

Hydraulic system pressure released
(page 2-1191)

2-1499

HYDRAULIC IMPACTOR FLOW REGULATOR-TO-BOOM OIL LINE (SERIAL NUMBERS 235786 THRU 235999 ONLY) - CONTINUED

LOCATION	ITEM	ACTION REMARKS
REMOVAL		
<u>WARNING</u>		
<p>Do not attempt to disconnect hydraulic lines and fittings while engine is running or before hydraulic system pressure has been released. When engine is running, hydraulic system is under pressure. Hydraulic system pressure should be 0 psi (0 kPa) before lines are disconnected. A line or fitting disconnected under pressure will blow off with a lot of force and could cause serious injury to personnel.</p>		
<p>Be careful when draining hot fluids. Wear gloves to protect your hands from hot parts and fluids or severe burns could result.</p>		
1.Elbow (1)	Hose (2)	a. Place drain pan underneath. b. Using 1 1/8-inch and 1 1/4-inch open-end wrenches, unscrew and take out. c. Tag (page 2-137).
2.Flow regulator (3)	Elbow (1)	a. Note relative position for proper placement during installation. b. Using 1 1/4-inch and 1 3/8-inch open-end wrenches, unscrew and take out. c. Plug regulator (3) (page 2-137).
3.Clamp (4) and manifold block (5)	Screw (6) and special nut (7)	a. Using 9/16-inch, 1/2-inch drive socket, ratchet handle, and 9/16-inch box wrench, unscrew and take apart. b. Get rid of special nut (7).
4.Manifold block (5), hose (2), and isolator (8)	Clamp (4)	Take off.
5.Manifold block (5)	Hose (2)	Take off.
6.Hose(9)	Hose (2)	a. Place drain pan underneath. b. Using 1 1/8-inch and 1 1/4-inch open-end wrenches, unscrew and take out. c. Tag hose (9) (page 2-137). d. Plug hose (9) (page 2-137). e. Get rid of drained fluid (page 2-137).

HYDRAULIC IMPACTOR FLOW REGULATOR-TO-BOOM OIL LINE (SERIAL NUMBERS 235786 THRU 235999 ONLY) - CONTINUED

LOCATION	ITEM	ACTION	REMARKS
7.Boom (10) and guard (11)	Hose (2)	<ul style="list-style-type: none"> a. Attach 5-foot length of lacing and tying tape. b. With aid of assistant, pull out. c. Take off lacing and tying tape, leaving it in position to aid in routing during installation. 	

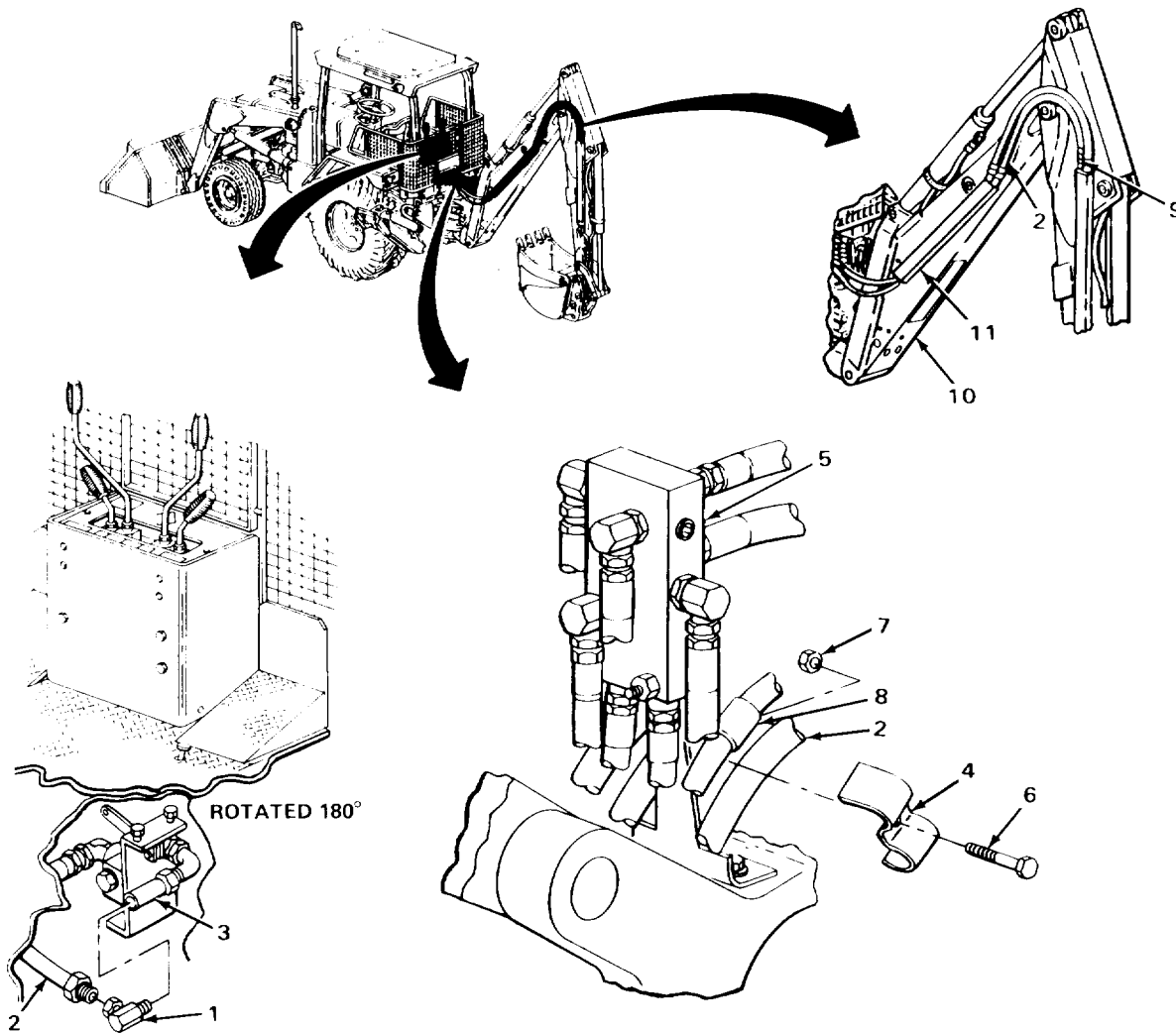

HYDRAULIC IMPACTOR FLOW REGULATOR-TO-BOOM OIL LINE (SERIAL NUMBERS 235786 THRU 235999 ONLY) - CONTINUED

LOCATION	ITEM	ACTION	REMARKS
----------	------	--------	---------

CLEANING

NOTE

For more information on how to clean parts, go to **General Maintenance Instructions (page 2-137)**.

- | | | |
|----|----------|---|
| 8. | Hose (1) | <ul style="list-style-type: none"> a. Using clean rags dampened in solution of detergent and water, wipe clean. b. Rinse with clean water. c. Using clean, dry rags, wipe dry. |
|----|----------|---|

WARNING

Drycleaning solvent P-D-680 is toxic and flammable. Wear protective goggles and gloves and use only in a well ventilated area. Avoid contact with skin, eyes, and clothes and don't breathe vapors. Do not use near open flame or excessive heat. The flashpoint is 100°F to 138°F (38° to 59°C). If you become dizzy while using cleaning solvent, get fresh air immediately and get medical aid. If contact with eyes is made, wash your eyes with water and get medical aid immediately.

- | | | |
|----|-----------------|---|
| 9. | All metal parts | <ul style="list-style-type: none"> a. Clean in drycleaning solvent. b. Using clean, dry rags, wipe dry. |
|----|-----------------|---|

INSPECTION/REPLACEMENT

NOTE

For more information on how to inspect parts, go to **General Maintenance Instructions (page 2-137)**.

Replace defective parts as needed.

- | | | |
|-----|--------------------|--|
| 10. | Hose (1) | Look for cracks, breaks, cuts, and tears. |
| 11. | All metal parts | Look for cracks, breaks, and abnormal bends. |
| 12. | All threaded parts | Look for damaged threads. |

INSTALLATION

- | | | |
|---------------------------|----------|---|
| 13.Boom (2) and guard (3) | Hose (1) | <ul style="list-style-type: none"> a. Attach lacing and tying tape. b. With aid of assistant, pull into position. c. Take off lacing and tying tape. |
|---------------------------|----------|---|

HYDRAULIC IMPACTOR FLOW REGULATOR-TO-BOOM OIL LINE (SERIAL NUMBERS 235786 THRU 235999 ONLY) - CONTINUED

LOCATION	ITEM	ACTION REMARKS
14.Hose (4)	Hose (1)	a. Take tag off hose (4). b. Unplug hose (4). c. Screw in and tighten using 1 1/8-inch and 1 1/4-inch open-end wrenches.
15.Manifold block (5)	Hose (1)	Place in position.
16.Manifold block (5), hose (1), and isolator (6)	Clamp (7)	Place in position.
17.Clamp (7) and manifold block (5)	Screw (8) and special nut (9)	Screw together and tighten using 9/16-inch, 1/2-inch drive socket, ratchet handle, and 9/16-inch box wrench.

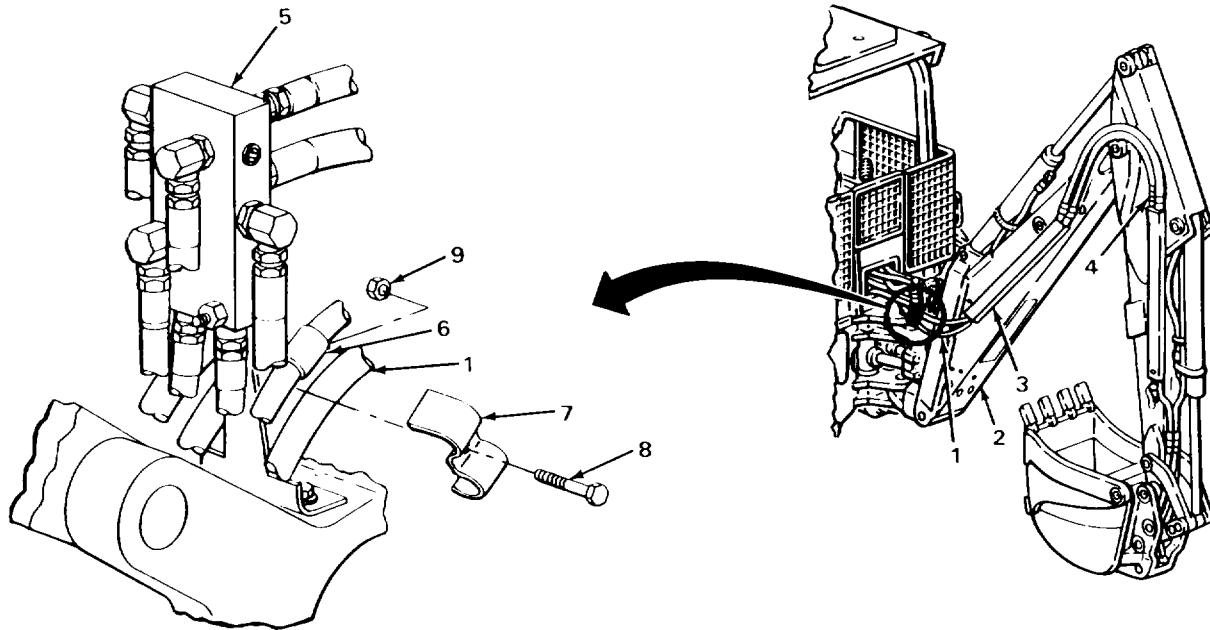

HYDRAULIC IMPACTOR FLOW REGULATOR-TO-BOOM OIL LINE (SERIAL NUMBERS 235786 THRU 235999 ONLY) - CONTINUED

LOCATION	ITEM	ACTION	REMARKS
INSTALLATION - CONTINUED			
18.Flow regulator (1)	Elbow (2)	a. Unplug regulator (1). b. Screw in and tighten using 1 1/4-inch and 1 3/8-inch open-end wrenches.	
19.Elbow (2)	Hose (3)	a. Take off tag. b. Screw in and tighten using 1 1/8-inch and 1 1/4-inch open-end wrenches.	

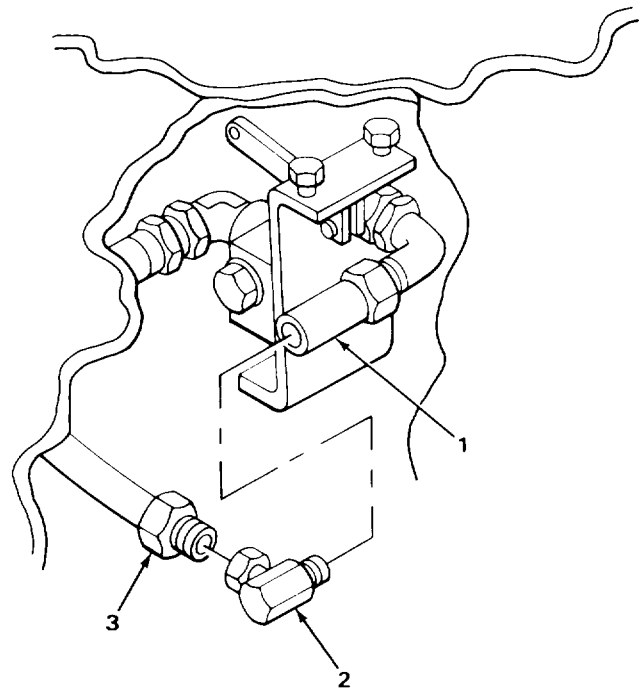
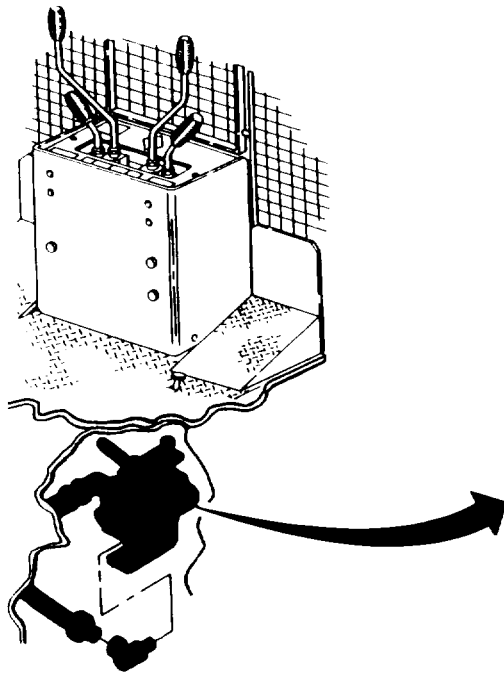

TASK ENDS HERE

TA243452

HYDRAULIC IMPACTOR FLOW REGULATOR-TO-BOOM OIL LINE (SERIAL NUMBERS 319995 THRU 342573 ONLY)

This task covers:

- a. Removal (page 2-1505)
- b. Cleaning (page 2-1508)
- c. Inspection/Replacement (page 2-1509)
- d. Installation (page 2-1510)

INITIAL SETUP:

Tools

- Handle, ratchet, 1/2-inch drive
- Pan, drain
- Pliers, diagonal-cutting
- Pliers, slip-joint
- Socket, 11/2-inch drive, 9/16-inch
- Wrench, open-end, 9/16-inch
- Wrench, open-end, 1 1/8-inch
- Wrench, open-end, 11/4-inch
- Wrench, open-end, 11/2-inch

Materials/Parts - Continued

- Nut, special (two required)
- Rags, wiping (item 21, Appendix C)
- Solvent, drycleaning (item 28, Appendix C)
- Tags, marking (item 30, Appendix C)

Personnel Required

One

Materials/Parts

- Band (as required)
- Detergent, GP (item 7, Appendix C)

LOCATION	ITEM	ACTION REMARKS
REMOVAL		
1.Loader backhoe	Boom, dipperstick, and bucket	<ul style="list-style-type: none"> a. Extend as far as possible (TM 5-2420-222-10). b. Lower to ground so that boom and dipperstick are horizontal (TM 5-2420-222-10).
2.	Hydraulic system	Release pressure (page 2-1191).

HYDRAULIC IMPACTOR FLOW REGULATOR-TO-BOOM OIL LINE (SERIAL NUMBERS 319995 THRU 342573 ONLY) - CONTINUED

LOCATION	ITEM	ACTION	REMARKS
----------	------	--------	---------

REMOVAL - CONTINUED
WARNING

Do not attempt to disconnect hydraulic lines and fittings while engine is running or before hydraulic system pressure has been released. When engine is running, hydraulic system is under pressure. Hydraulic system pressure should be 0 psi (0 kPa) before lines are disconnected. A line or fitting disconnected under pressure will blow off with a lot of force and could cause serious injury to personnel.

Be careful when draining hot fluids. Wear gloves to protect your hands from hot parts and fluids or severe burns could result.

3.Elbow (1)	Hose (2)	a. Place drain pan underneath. b. Using 1 1/8-inch and 1 1/4-inch open-end wrenches, unscrew and take out. c. Tag (page 2-137).
4.Flow regulator (3)	Elbow (1)	a. Note relative position for proper placement during installation. b. Using 1 1/4-inch and 1 1/2-inch open-end wrenches, unscrew and take out. b. Plug regulator (3) (page 2-137).
5.Bracket (4) and clamp (5)	Screw (6) and special nut (7)	a. Using 9/16-inch, 1/2-inch drive socket, ratchet handle, and 9/16-inch open-end wrench, unscrew and take apart. b. Get rid of special nut (7).
6.Bracket (4), isolator (8), and twp hoses (2 and 9)	Clamp (5)	Take off.
7.Bracket (4)	Hose (2)	Take off.
8.Boom (10) and clamp (11)	Screw (12) and special nut (13),	a. Using 9/16-inch, 1/2-inch drive socket, ratchet handle, and 9/16-inch open-end wrench, unscrew and take apart. b. Get rid of special nut (13).
9.Boom (10) and tube (14)	Clamp (11)	Take off.

HYDRAULIC IMPACTOR FLOW REGULATOR-TO-BOOM OIL LINE (SERIAL NUMBERS 31995 THRU 342573 ONLY) - CONTINUED

LOCATION	ITEM	ACTION	REMARKS
----------	------	--------	---------

10.Nine hoses (2 and 15 thru 22)

Bands (23)

- a. Note relative position for proper placement during installation.
- b. Using diagonal-cutting pliers, cut off.
- c. Get rid of.

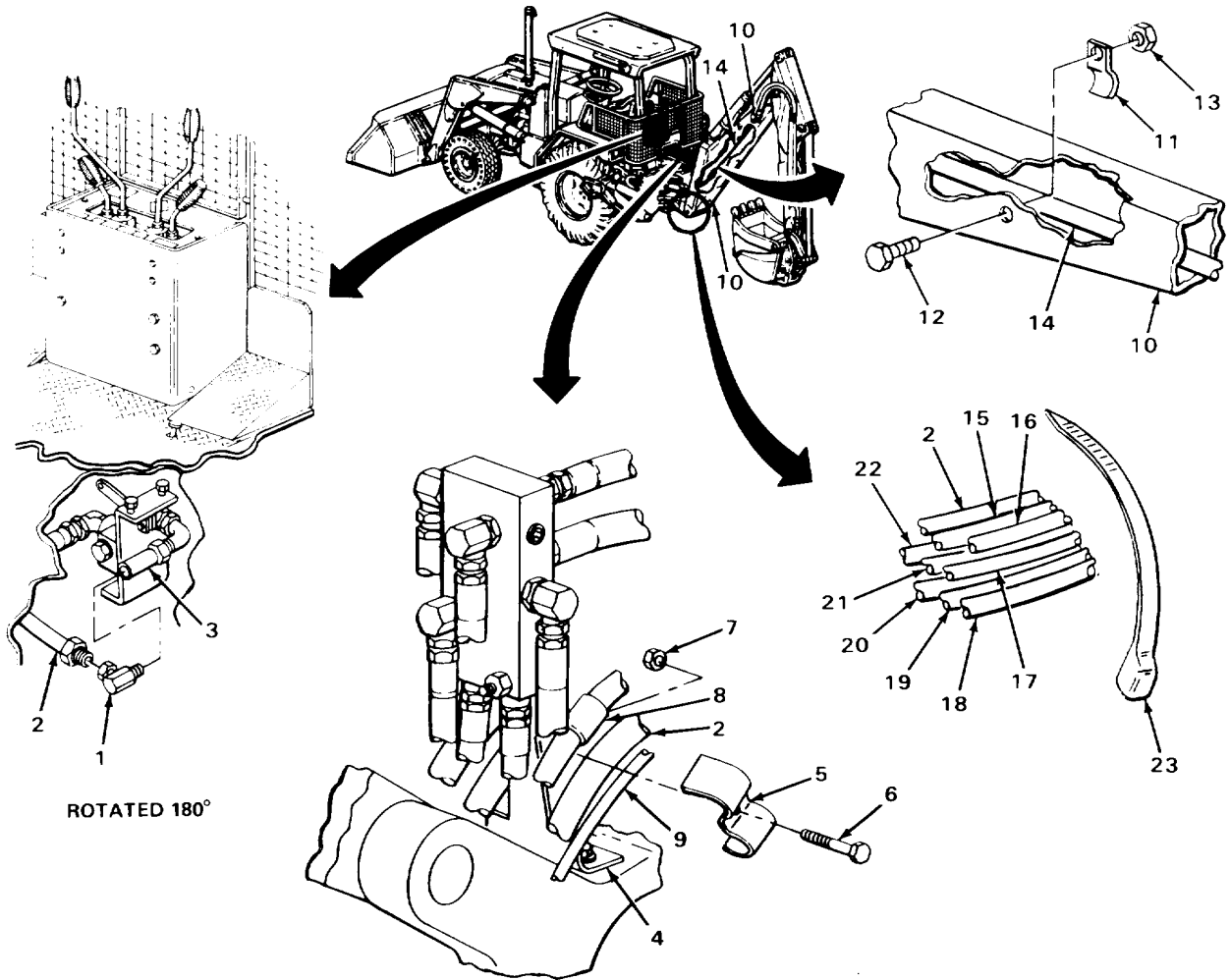

HYDRAULIC IMPACTOR FLOW REGULATOR-TO-BOOM OIL LINE (SERIAL NUMBERS 319995 THRU 342573 ONLY) - CONTINUED

LOCATION	ITEM	ACTION	REMARKS
REMOVAL - CONTINUED			
11.Tube (1)	Hose (2)	<ul style="list-style-type: none"> a. Place drain pan underneath. b. Using 1 1/8-inch and 1 1/4-inch open-end wrenches, unscrew and take out. c. Tag (page 2-137). 	
12.	Hose (3)	<ul style="list-style-type: none"> a. Place drain pan underneath. b. Using 1 1/4-inch open-end wrench, unscrew and take off. c. Cap (page 2-137). 	
13.Boom (4) and tube (1)	Jamnut (5)	Using 1 1/4-inch open-end wrench, unscrew and take off.	
14.Boom (4)	Tube (1)	<ul style="list-style-type: none"> a. Take out. b. Tag (page 2-137). c. Get rid of drained fluid (page 2-137). 	

CLEANING

NOTE

For more information on how to clean parts, go to General Maintenance Instructions (page 2-137).

15.	Hose (2)	<ul style="list-style-type: none"> a. Using clean rags dampened in solution of detergent and water, wipe clean. b. Rinse with clean water. c. Using clean, dry rags, wipe dry. 	
-----	----------	---	--

WARNING

Drycleaning solvent P-D-680 is toxic and flammable. Wear protective goggles and gloves and use only in a well ventilated area. Avoid contact with skin, eyes, and clothes and don't breathe vapors. Do not use near open flame or excessive heat. The flashpoint is 100°F to 138°F (38° to 59°C). If you become dizzy while using cleaning solvent, get fresh air immediately and get medical aid. If contact with eyes is made, wash your eyes with water and get medical aid immediately.

16.	All metal parts	<ul style="list-style-type: none"> a. Clean in drycleaning solvent. b. Using clean, dry rags, wipe dry. 	
-----	-----------------	---	--

HYDRAULIC IMPACTOR FLOW REGULATOR-TO-BOOM OIL LINE (SERIAL NUMBERS 31995 THRU 342573 ONLY) - CONTINUED

LOCATION	ITEM	ACTION	REMARKS
----------	------	--------	---------

INSPECTION/REPLACEMENT

NOTE

For more information on how to inspect parts, go to General Maintenance Instructions (page 2-137).

Replace defective parts as needed.

- | | | |
|-----|--------------------|--|
| 17. | Hose (2) | Look for cracks, breaks, cuts, and tears. |
| 18. | All metal parts | Look for cracks and breaks and abnormal bends. |
| 19. | All threaded parts | Look for damaged threads. |

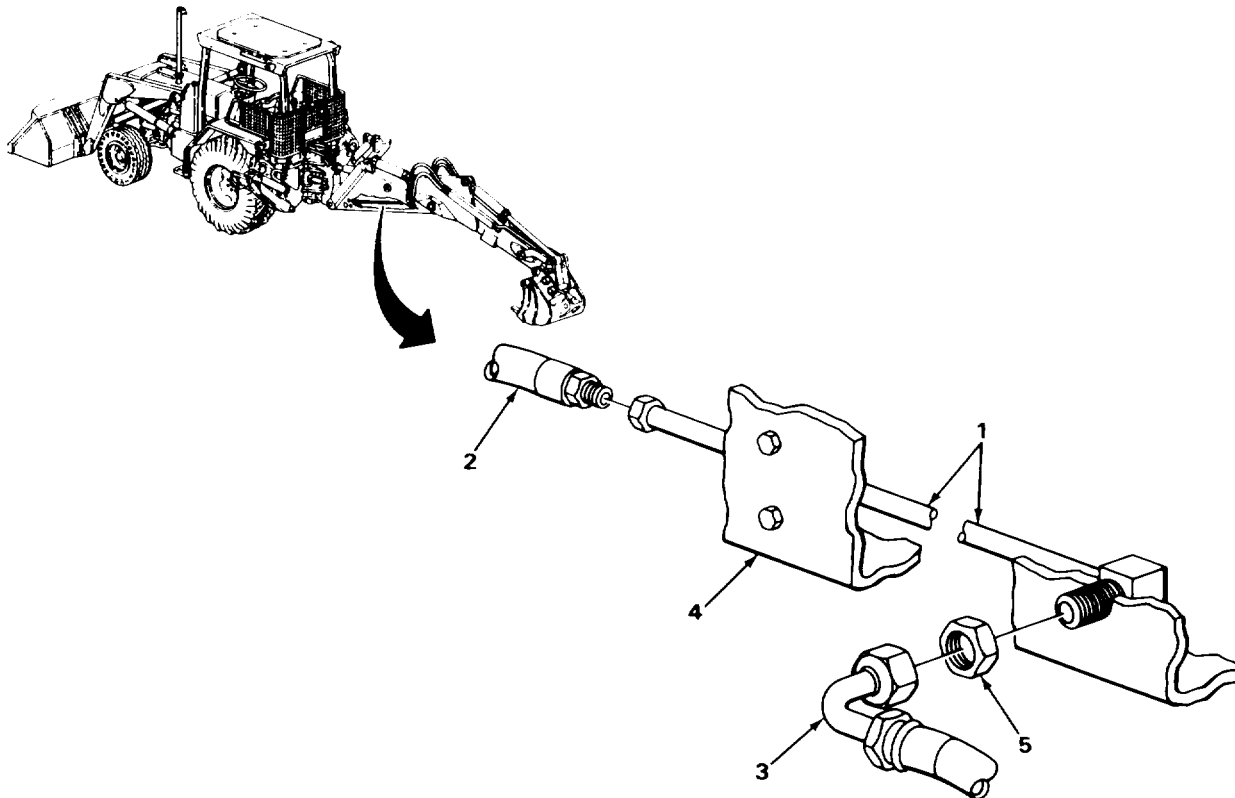

HYDRAULIC IMPACTOR FLOW REGULATOR-TO-BOOM OIL LINE (SERIAL NUMBERS 319995 THRU 342573 ONLY) - CONTINUED

LOCATION	ITEM	ACTION REMARKS
INSTALLATION		
20.Boom (1)	Tube (2)	a. Place in position. b. Take off tag.
21.Boom (1) and tube (2)	Jamnut (3)	Screw on and tighten using 1 1/4-inch open-end wrench.
22.Tube (2)	Hose (4)	a. Uncap. b. Screw on and tighten using 1 1/4-inch open-end wrench.
23.	Hose (5)	a. Take off tag. b. Screw on and tighten using 1 1/8-inch and 1 1/4 inch open-end wrenches.
24.Nine hoses (5 thru 13)	New bands (14)	a. Place same quantity in relative positions noted during removal. b. Using slip-joint pliers, tighten until snug.
25.Boom (1) and tube (2)	Clamp (15)	Place in position.
26.Boom (1) and clamp (15)	Screw (16) and new special nut (17)	Screw together and tighten using 9/16-inch, 1/2-inch drive socket, ratchet handle, and 9/16-inch open-end wrench.
27.Bracket (18)	Hose (5)	Place in position.
28.Bracket (18), two hoses (5 and 19), and isolator (20)	Clamp (21)	Place in position.
29.Bracket (18) and clamp (21)	Screw (22) and new special nut (23)	Screw together and tighten using 9/16-inch, 1/2-inch drive socket, ratchet handle, and 9/16-inch open-end wrench.

HYDRAULIC IMPACTOR FLOW REGULATOR-TO-BOOM OIL LINE (SERIAL NUMBERS 31995 THRU 342573 ONLY) - CONTINUED

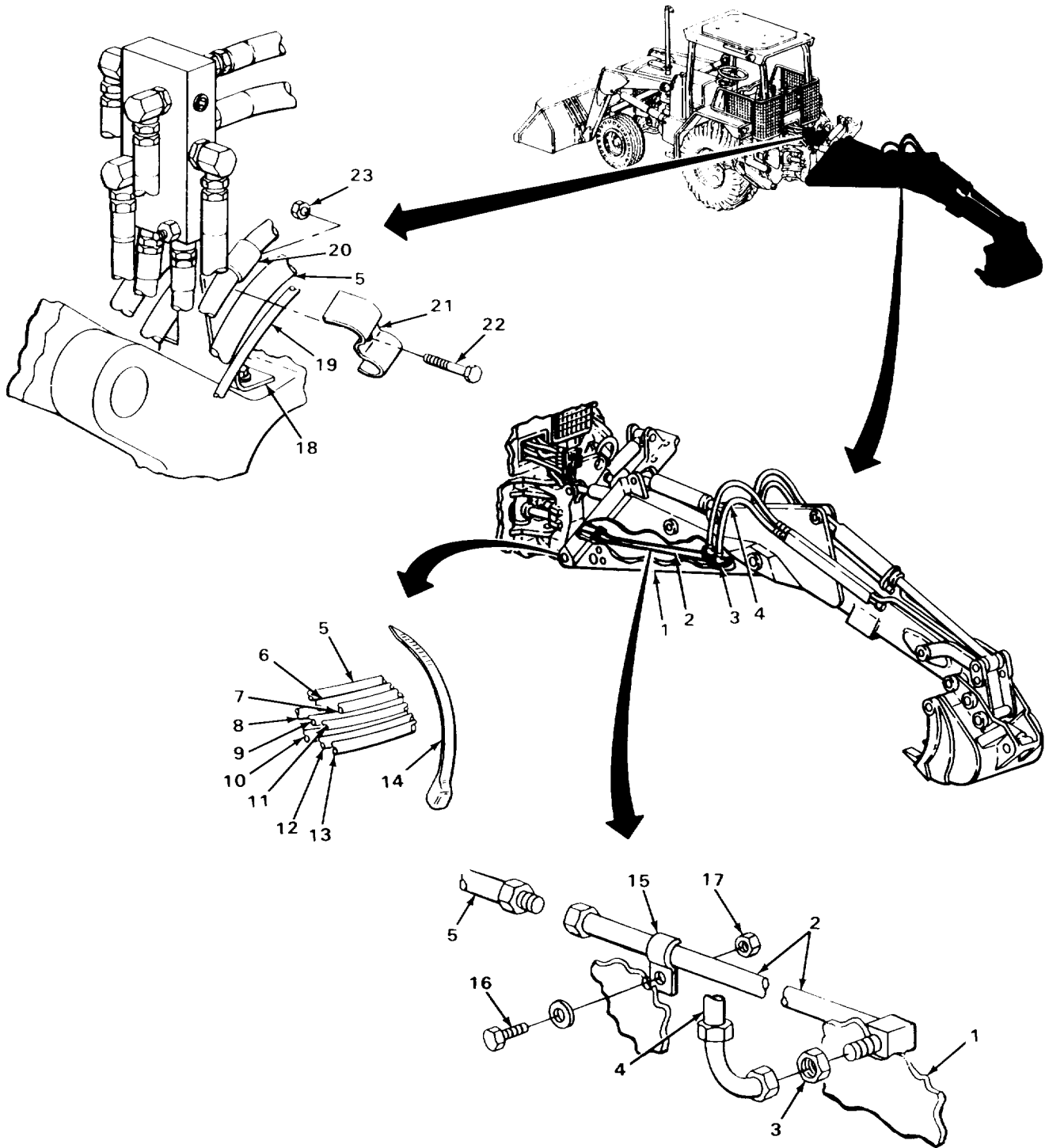

HYDRAULIC IMPACTOR FLOW REGULATOR-TO-BOOM OIL LINE (SERIAL NUMBERS 319995 THRU 342573 ONLY) - CONTINUED

LOCATION	ITEM	ACTION	REMARKS
INSTALLATION - CONTINUED			
30.Flow regulator (1)	Elbow (2)	a. Unplug regulator (1). b. Screw in and tighten to same relative position noted during removal using 1 1/4-inch and 1 1/2-inch open-end wrenches.	
31.Elbow (2)	Hose (3)	a. Take off tag. b. Screw in and tighten using 1 1/8-inch 1/4-inch open-end wrenches.	

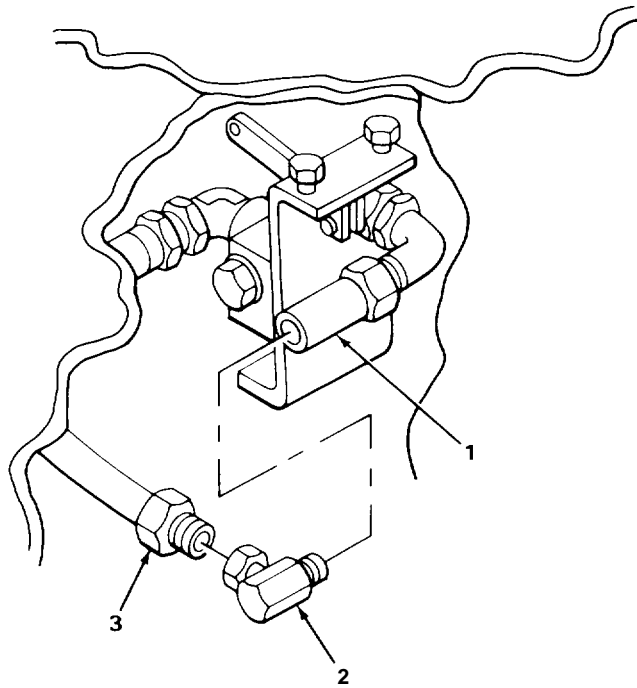
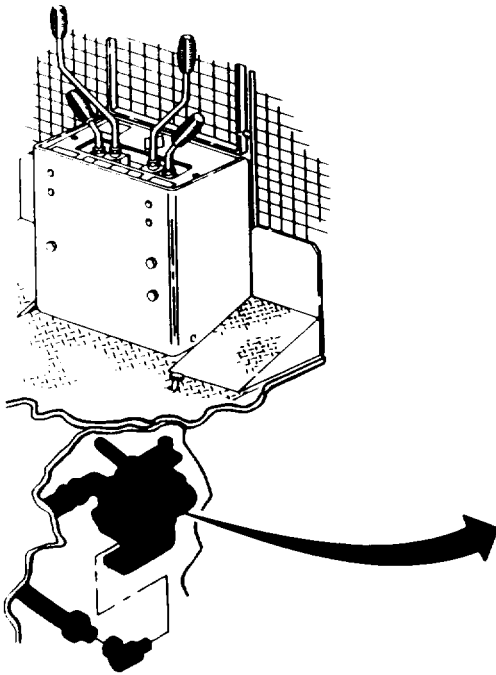

TASK ENDS HERE

TA343455

JAW CONTROL (DIRECT LINEAR) VALVE-TO-MANIFOLD BLOCK OIL LINES

LOCATION	ITEM	ACTION	REMARKS
----------	------	--------	---------

This task covers:

- | | |
|---|--|
| <ul style="list-style-type: none"> a. Removal (page 2-1513) b. Cleaning (page 2-1516) | <ul style="list-style-type: none"> c. Inspection/Replacement (page 2-1517) d. Installation (page 2-1517) |
|---|--|

INITIAL SETUP

Tools

- Handle, ratchet, 3/8-inch drive
- Knife, pocket
- Pan, drain
- Pliers, diagonal-cutting
- Pliers, slip-joint
- Socket, 3/8-inch drive, 9/16-inch
- Wrench, box, 9/16-inch
- Wrench, open-end box, 7/16-inch
- Wrench, open-end, 5/8-inch
- Wrench, open-end, 11/16-inch
- Wrench, open-end, 3/4-inch
- Wrench, open-end, 13/16-inch
- Wrench, open-end, 7/8-inch

Materials/Parts

- Band
- Detergent, GP (item 7, Appendix C)
- Lockwasher, clamp screw
- Nut, special (two required)
- Packing elbow (two required)
- Rags, wiping (item 21, Appendix C)
- Solvent, dry-cleaning (item 28, Appendix C)
- Tags, marking (item 30, Appendix C)

Personnel Required

One

LOCATION	ITEM	ACTION	REMARKS
----------	------	--------	---------

NOTE

Both jaw control (direct linear) valve-to-manifold block oil lines are maintained the same way except as noted. Oil line to jaw cylinder rod end is shown. Repeat procedures as needed for oil line to jaw cylinder head end.

REMOVAL

- | | | | |
|----|------------------|-------------------------------|--|
| 1. | Loader backhoe | Boom, dipperstick, and bucket | <ul style="list-style-type: none"> a. Extend as far as possible (TM 5-2420-222-10). b. Lower to ground so that boom and dipperstick are horizontal (TM 5-2420-222-10). |
| 2. | Hydraulic system | | Release pressure (page 2-1191). |

JAW CONTROL (DIRECT LINEAR) VALVE-TO-MANIFOLD BLOCK OIL LINES - CONTINUED

LOCATION	ITEM	ACTION	REMARKS
----------	------	--------	---------

REMOVAL - CONTINUED

WARNING

Do not attempt to disconnect hydraulic lines and fittings while engine is running or before hydraulic system pressure has been released. When engine is running, hydraulic system is under pressure. Hydraulic system pressure should be 0 psi (0 kPa) before lines are disconnected. A line or fitting disconnected under pressure will blow off with a lot of force and could cause serious injury to personnel.

Be careful when draining hot fluids. Wear gloves to protect your hands from hot parts and fluids or severe burns could result.

- | | | |
|--------------|----------|---|
| 3. Elbow (1) | Hose (2) | a. Place drain pan underneath.
b. Using 11/16-inch and 7/8-inch open-end wrenches, unscrew and take off.
c. Tag (page 2-137). |
|--------------|----------|---|

NOTE

Oil line to jaw cylinder rod end has a check valve attached to bulkhead elbow. Oil line to jaw cylinder head end does not have a check valve. If removing oil line to jaw cylinder head end, skip steps 4 and 5.

- | | | |
|----------------------------|---|--|
| 4. Elbow (3) | Tube (4) | a. Using 7/16-inch open-end box wrench, unscrew and take out.
b. Cap (page 2-137). |
| 5. Elbow (1) | Check valve (5) with assembled elbow (3) and nipple (6) | a. Note relative position for proper placement during installation.
b. Using 5/8-inch open-end wrench, unscrew and take out. |
| 6. Valve (7) and elbow (1) | Nut (8) | Using 13/16-inch and 7/8-inch open-end wrenches, loosen. |
| 7. Valve (7) | Elbow (1) with assembled parts | a. Note relative position for proper placement during installation.
b. Using 13/16-inch open-end wrench, unscrew and take out.
c. Plug valve (7) (page 2-137). |
| 8. Elbow (1) | Packing (9) | a. Using pocket knife, take off.
b. Get rid of. |

JAW CONTROL (DIRECT LINEAR) VALVE-TO-MANIFOLD BLOCK OIL LINES - CONTINUED

LOCATION	ITEM	ACTION REMARKS
9. Bracket (10) and clamp (11)	Screw (12) and special nut (13)	a. Using 9/16-inch, 3/8-inch drive socket, ratchet handle, and 9/16-inch box wrench, unscrew and take apart. b. Get rid of special nut (13).
10. Bracket (10), two hoses (14 and 15), and isolator (16)	Clamp (11)	Take off.
11. Bracket (10)	Hose (2) with assembled isolator (16)	Take off.

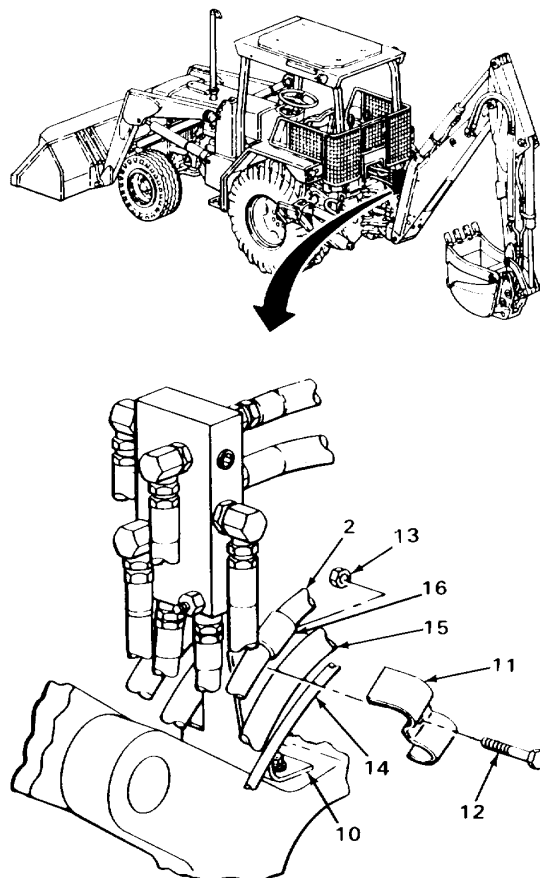
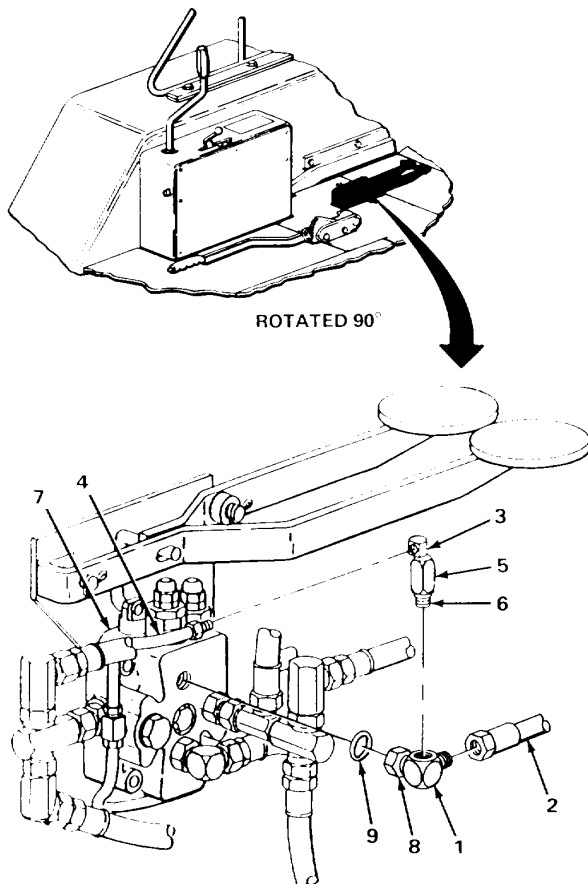

TA243457

JAW CONTROL (DIRECT LINEAR) VALVE-TO-MANIFOLD BLOCK OIL LINES - CONTINUED

LOCATION	ITEM	ACTION	REMARKS
REMOVAL - CONTINUED			
12.	Hose (1)	Isolator (2)	Take off.
13.	Nine hoses (1 and 3 thru 10)	Band (11)	a. Using diagonal-cutting pliers, cut off. b. Get rid of.
14.	Three clamps (12 thru 14), spacer (15) and boom (16)	Screw (17) and lockwasher (18)	a. Using 9/16-inch, 3/8-inch drive socket and ratchet handle, unscrew and take out. b. Get rid of lockwasher (18).
15.	Two tubes (19 and 20) and clamp (14)	Two clamps (12 and 13) and spacer (15)	Take off.
16.	Tube (19)	Hose (1)	a. Place drain pan underneath. b. Using 3/4-inch and 7/8-inch open-end wrenches, unscrew and take off. c. Tag (page 2-137). d. Cap tube (19) (page 2-137).
17.	Boom (16)	Hose (1)	Noting routing, pull out.

CLEANING

NOTE

For more information on how to clean parts, go to **General Maintenance Instructions (page 2-137)**.

18.	All rubber parts	a. Using clean rags dampened in solution of detergent and water, wipe clean. b. Rinse with clean water. c. Using clean, dry rags, wipe dry.
-----	------------------	---

WARNING

Drycleaning solvent P-D-680 is toxic and flammable. Wear protective goggles and gloves and use only in a well ventilated area. Avoid contact with skin, eyes, and clothes and don't breathe vapors. Do not use near open flame or excessive heat. The flashpoint is 100°F to 138°F (38° to 59°C). If you become dizzy while using cleaning solvent, get fresh air immediately and get medical aid. If contact with eyes is made, wash your eyes with water and get medical aid immediately.

19.	All metal parts	a. Clean in drycleaning solvent. b. Using clean, dry rags, wipe dry.
-----	-----------------	---

JAW CONTROL (DIRECT LINEAR) VALVE-TO-MANIFOLD BLOCK OIL LINES - CONTINUED

LOCATION	ITEM	ACTION	REMARKS
----------	------	--------	---------

INSPECTION/REPLACEMENT

NOTE

For more information on how to inspect parts, go to General Maintenance Instructions (page 2-137).
 Replace defective parts as needed.

20.	All rubber parts	Look for cracks, breaks, cuts, and tears.
21.	All metal parts	Look for cracks and breaks and abnormal bends.
22.	All threaded parts	Look for damaged threads.

INSTALLATION

23.	Boom (16)	Hose (1)	Using same routing noted during removal, place in position.
-----	-----------	----------	---

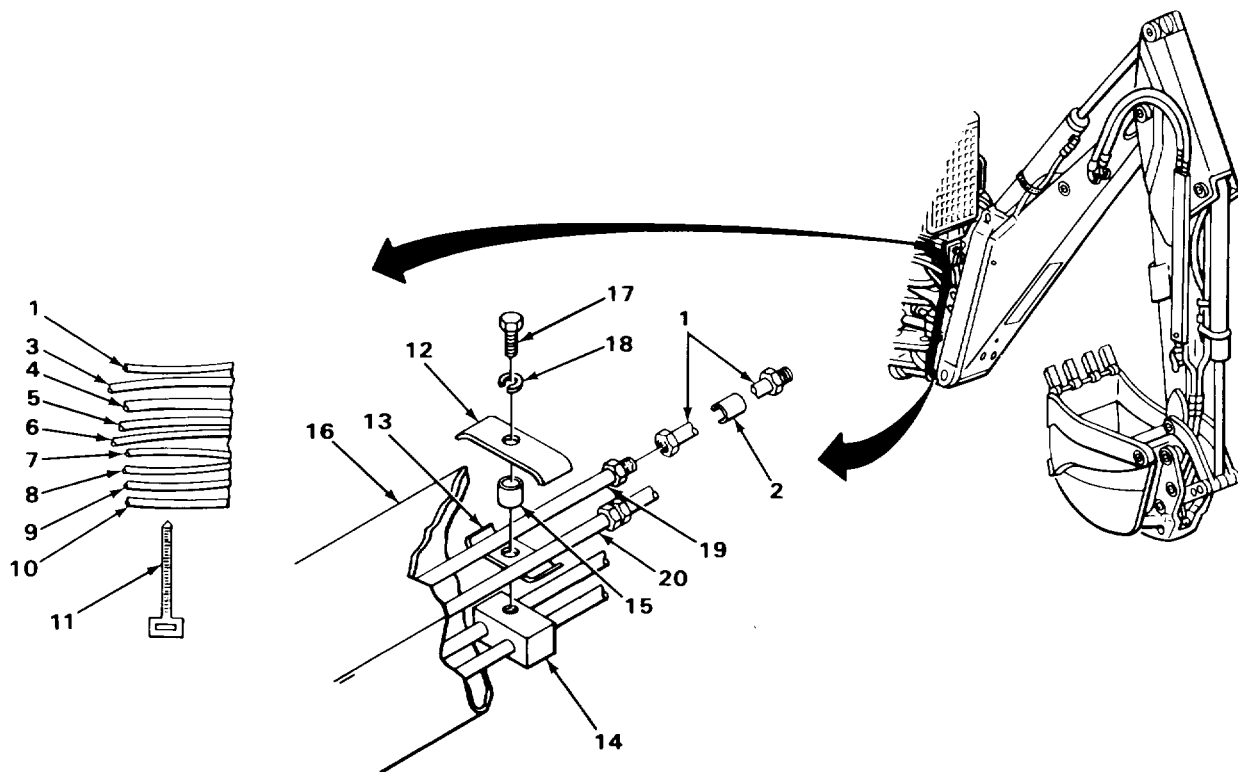

TA243458

JAW CONTROL (DIRECT LINEAR) VALVE-TO-MANIFOLD BLOCK OIL LINES - CONTINUED

LOCATION	ITEM	ACTION	REMARKS
INSTALLATION - CONTINUED			
24.	Tube (1)	Hose (2)	a. Uncap tube (1). b. Screw on and tighten using 3/4-inch and 7/8 inch open-end wrenches. c. Take off tag.
25.	Two tubes (1 and 3 and clamp (4)	Two clamps (5 and 6) and spacer (7)	Place in position.
26.	Three clamps (4 thru 6), spacer (7) and boom (8)	Screw (9) and new lockwasher (10)	Screw in and tighten using 9/16-inch, 3/8-inch drive socket and ratchet handle.
27.	Nine hoses (2 and 11 thru 18)	New band (19)	a. Place in position. b. Using slip-joint pliers, tighten until snug.

NOTE

New isolators are manufactured from bulk items. For more information on manufacturing new isolators, refer to Appendix D).

28.	Hose (2)	Isolator (20)	Place in position.
29.	Bracket (21)	Hose (2) with assembled isolator (20)	Place in position.
30.	Bracket (21), two hoses (11 and 12), and isolator (20)	Clamp (22)	Place in position.
31.	Bracket (21) and clamp (22)	Screw (23) and new special nut (24)	Screw together and tighten using 9/16-inch, 3/8-inch drive socket, ratchet handle, and 9/16-inch box wrench.
32.	Elbow (25)	Nut (26)	Screw on all the way.
33.		New packing (27)	Place in position.
34.	Valve (28)	Elbow (25) with assembled parts	a. Unplug valve (28). b. Screw in to same relative position noted during removal using 13/16-inch open-end wrench.

JAW CONTROL (DIRECT LINEAR) VALVE-TO-MANIFOLD BLOCK OIL LINES - CONTINUED

LOCATION	ITEM	ACTION	REMARKS
----------	------	--------	---------

- | | | | |
|-------------------------------|----------|---|--|
| 35. Valve (28) and elbow (25) | Nut (26) | Using 13/16-inch and 7/8-inch open-end wrenches, tighten until seated against valve (28). | |
|-------------------------------|----------|---|--|

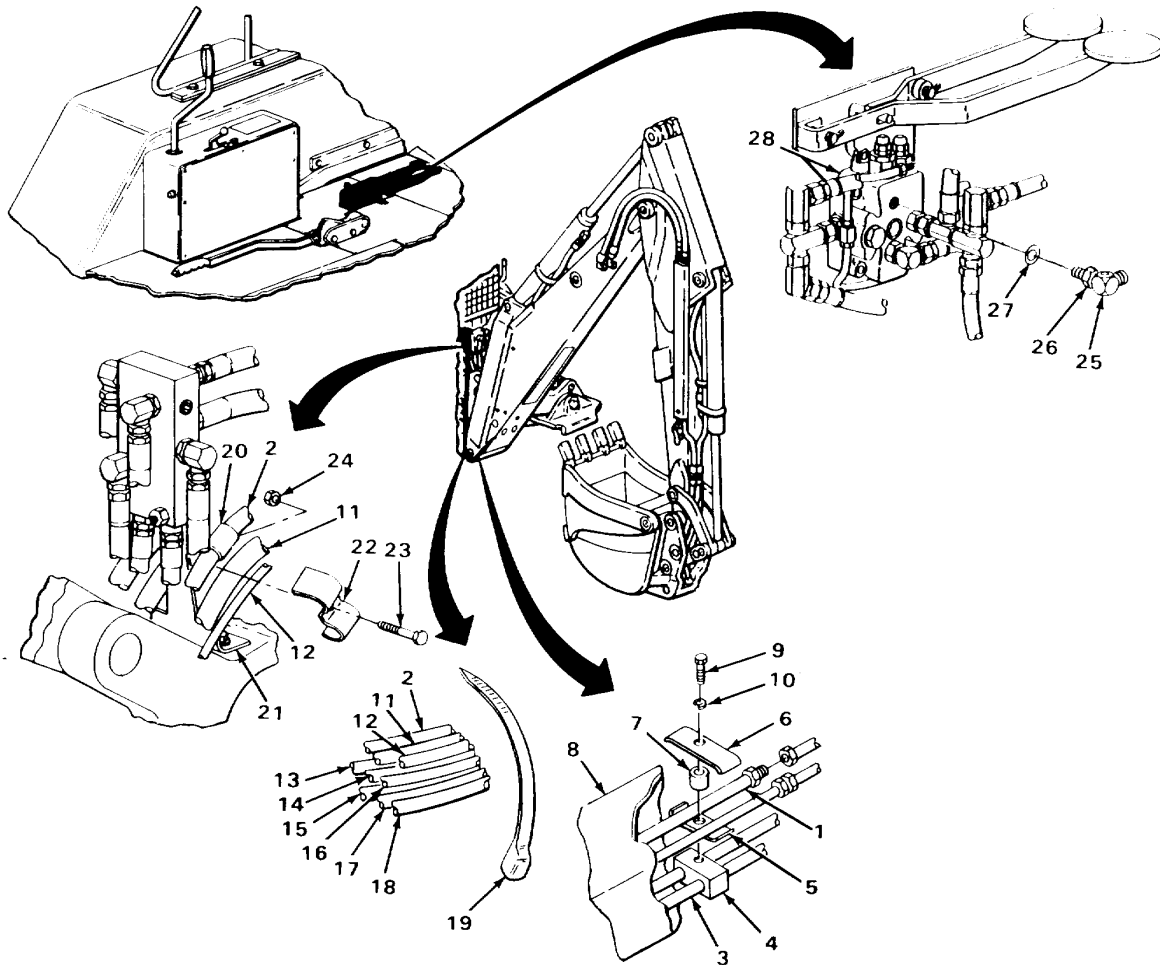

TA243459

JAW CONTROL (DIRECT LINEAR) VALVE-TO-MANIFOLD BLOCK OIL LINES - CONTINUED

LOCATION	ITEM	ACTION	REMARKS
INSTALLATION - CONTINUED			
NOTE			
If oil line-to-jaw cylinder head end is being installed, skip steps 36 and 37.			
36.	Elbow (1)	Check valve (2) with assembled elbow (3) and nipple (4)	Screw in and tighten to same relative position noted during removal using 5/8-inch open-end wrench.
37.	Elbow (3)	Tube (5)	a. Uncap. b. Screw in and tighten using 7/16-inch open-end wrench.
38.	Elbow (1)	Hose (6)	a. Take off tag. b. Screw in and tighten using 11/16-inch and 7/8-inch open-end wrenches.
39.	Loader backhoe	Transmission	Check fluid level and add proper amount and grade (TM 5-2420-222-10).
40.		Engine	Start and run at high idle (TM 5-2420-222-10).
41.		Jaw control (direct linear) valve-to-manifold oil lines	a. Operate jaw controls (TM 5-2420-222-10). b. If leaking at any connection, tighten using 7/16-inch open-end box, 5/8-inch, 11/16-inch, 3/4-inch, 13/16-inch, and 7/8-inch open-end wrenches. c. If leaking does not stop, shut down engine (TM 5-2420-222-10) and replace leaking connection packing, fitting, or hose as outlined in this task. d. If found leaking, repeat steps 39 thru 41.
42.		Engine	If still running, shut down (TM 5-2420-222-10).

JAW CONTROL (DIRECT LINEAR) VALVE-TO-MANIFOLD BLOCK OIL LINES - CONTINUED

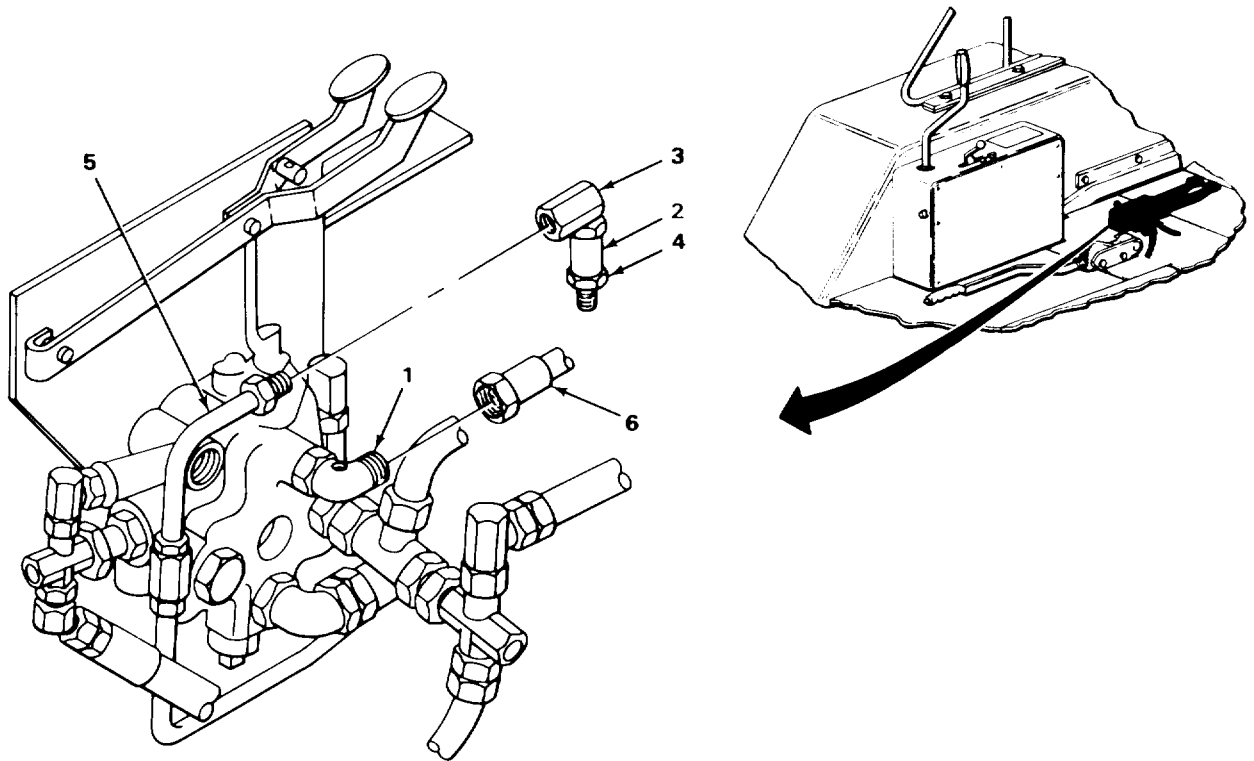

TASK ENDS HERE

MANIFOLD BLOCK-TO-BOOM JAW CONTROL OIL HOSES (SERIAL NUMBERS 235786 THRU 235999 ONLY)

This task covers:

- a. Removal (page 2-1522)
- b. Cleaning (page 2-1524)
- c. Inspection/Replacement (page 2-1524)
- d. Installation (page 2-1525)

INITIAL SETUP

Tools

- Pan, drain
- Wrench, open-end, 3/4-inch
- Wrench, open-end, 7/8-inch
- Wrench, open-end, 1-inch

Materials/Parts - Continued

- Tape, lacing and tying
(item 33, Appendix C)

Personnel Required

Two

Materials/Parts

- Detergent, GP (item 7, Appendix C)
- Rags, wiping (item 21, Appendix C)
- Solvent, drycleaning
(item 28, Appendix C)
- Tags, marking (item 30, Appendix C)

LOCATION	ITEM	ACTION	REMARKS
----------	------	--------	---------

NOTE

Both manifold block-to boom jaw control oil hoses are maintained the same way. Oil hose to jaw cylinder rod end is shown. Repeat procedures as needed for oil hose to jaw cylinder head end.

REMOVAL

- | | | |
|---------------------|---------------------------------|--|
| 1. Loader backhoe | Boom, dipperstick, and bucket | <ul style="list-style-type: none"> a. Extend as far as possible (TM 5-2420-222-10). b. Lower to ground so that boom and dipperstick are horizontal (TM 5-2420-222-10). |
| 2. Hydraulic system | Release pressure (page 2-1191). | |

MANIFOLD BLOCK-TO-BOOM JAW CONTROL OIL HOSES (SERIAL NUMBERS 235786 THRU 235999 ONLY) - CONTINUED

LOCATION	ITEM	ACTION	REMARKS
----------	------	--------	---------

WARNING

Do not attempt to disconnect hydraulic lines and fittings while engine is running or before hydraulic system pressure has been released. When engine is running, hydraulic system is under pressure. Hydraulic system pressure should be 0 psi (0 kPa) before lines are disconnected. A line or fitting disconnected under pressure will blow off with a lot of force and could cause serious injury to personnel.

Be careful when draining hot fluids. Wear gloves to protect your hands from hot parts and fluids or severe burns could result.

- | | | |
|--------------|----------|--|
| 3. Elbow (1) | Hose (2) | <ul style="list-style-type: none"> a. Place drain pan underneath. b. Using 7/8-inch and 1-inch open-end wrenches, unscrew and take off. c. Tag (page 2-137). d. Plug (page 2-137). |
|--------------|----------|--|

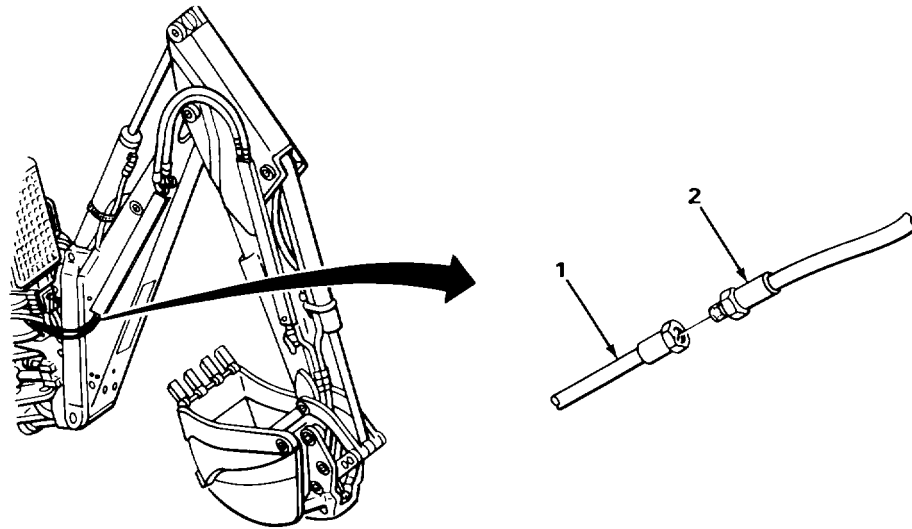

MANIFOLD BLOCK-TO-BOOM JAW CONTROL OIL HOSES (SERIAL NUMBERS 235786 THRU 235999 ONLY) - CONTINUED

LOCATION	ITEM	ACTION REMARKS
REMOVAL- CONTINUED		
4. Hose (1)	Tube (2)	a. Place drain pan underneath. b. Using 3/4-inch and 7/8-inch open-end wrenches, unscrew and take off. c. Plug (page 2-137). d. Tag (page 2-137). e. Get rid of drained fluid (page 2-137).
5. Boom (3) and	Hose (1)	a. Attach a foot length of lacing and guard (4) tying tape. b. With aid of assistant, pull out. c. Take off lacing and tying tape, leaving it in position to aid in installation. d. Tag (page 2-137).

CLEANING

NOTE

For more information on how to clean parts, go to **General Maintenance Instructions (page 2-137)**.

6.	Hose (1)	a. Using clean rags dampened in solution of detergent and water, wipe clean. b. Rinse with clean water. c. Using clean, dry rags, wipe dry.
----	----------	---

WARNING

Drycleaning solvent P-D-680 is toxic and flammable. Wear protective goggles and gloves and use only in a well ventilated area. Avoid contact with skin, eyes, and clothes and don't breathe vapors. Do not use near open flame or excessive heat. The flashpoint is 100°F to 138°F (38°C to 59°C). If you become dizzy while using cleaning solvent, get fresh air immediately and get medical aid. If contact with eyes is made, wash your eyes with water and get medical aid immediately.

7.	All metal parts	a. Clean in drycleaning solvent. b. Using clean, dry rags, wipe dry.
----	-----------------	---

INSPECTION/REPLACEMENT

NOTE

For more information on how to inspect parts, go to **General Maintenance Instructions (page 2-137)**. Replace defective parts as needed.

MANIFOLD BLOCK-TO-BOOM JAW CONTROL OIL HOSES (SERIAL NUMBERS 235786 THRU 235999 ONLY) - CONTINUED

LOCATION	ITEM	ACTION	REMARKS
8.	Hose (1)		Look for cracks, breaks, cuts, and tears.
9.	All threaded parts		Look for damaged threads.
INSTALLATION			
10.	Boom (3) and guard (4)	Hose (1)	<ol style="list-style-type: none"> Take off tag. Attach lacing and tying tape. With aid of assistant, pull into position. Take off lacing and tying tape.
11.	Hose (1)	Tube (2)	<ol style="list-style-type: none"> Unplug. Take off tag. Screw on and tighten using 3/4-inch and 7/8-inch open-end wrenches.
12.		Hose (5)	<ol style="list-style-type: none"> Unplug. Take off tag. Screw on and tighten using 7/8-inch and 1-inch open-end wrenches.
13.	Loader backhoe	Transmission	Check fluid level and add proper amount and grade (TM 5-2420-222-10).
14.		Engine	Start and run at high idle (TM 5-2420-222-10).

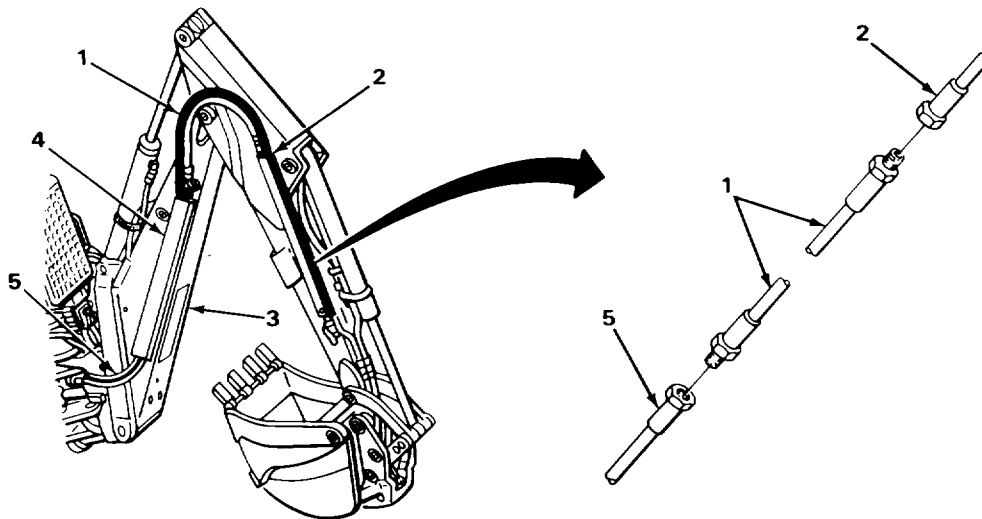

MANIFOLD BLOCK-TO-BOOM JAW CONTROL OIL HOSES (SERIAL NUMBERS 235786 THRU 235999 ONLY) - CONTINUED

LOCATION	ITEM	ACTION REMARKS
INSTALLATION - CONTINUED		
15.	Manifold block-to-boom jaw control oil lines	a. Check for leaks. b. If leaking at any connection, tighten using 3/4-inch, 7/8-inch, and 1-inch open-end wrenches. c. If leaking does not stop, shut down engine (TM 5-2420-222-10) and replace defective hose as outlined in this task. d. If found leaking, repeat steps 13 thru 15.
16.	Engine	If still running, shut down (TM 5-2420-222-10).

TASK ENDS HERE

MANIFOLD BLOCK-TO-BOOM JAW CONTROL OIL TUBES (SERIAL NUMBERS 319995 THRU 342573 ONLY)

This task covers:

- | | |
|---------------------------|---|
| a. Removal (page 2-1527) | c. Inspection/Replacement (page 2-1529) |
| b. Cleaning (page 2-1528) | d. Installation (page 2-1530) |

INITIAL SETUP

Tools

- Handle, ratchet, 3/8-inch drive
- Pan, drain
- Pliers, diagonal-cutting
- Pliers, slip-joint
- Socket, 3/8-inch drive, 9/16-inch
- Wrench, open-end, 3/4-inch
- Wrench, open-end, 7/8-inch
- Wrench, open-end, 1 1/8-inch

Materials/Parts

- Band, hose
- Lockwasher, clamp screw

Materials/Parts

- Rags, wiping (item 21, Appendix C)
- Solvent, drycleaning (item 28, Appendix C)
- Tags, marking (item 30, Appendix C)

Personnel Required

One

Equipment Condition

Hydraulic system pressure released (page 2-1191)

**MANIFOLD BLOCK-TO-BOOM JAW CONTROL OIL TUBES (SERIAL NUMBERS 31995 THRU 342573 ONLY)
--CONTINUED**

LOCATION	ITEM	ACTION	REMARKS
----------	------	--------	---------

NOTE

Both manifold block-to-boom jaw control oil tubes are maintained the same way. Oil tube-to-jaw cylinder rod end is shown. Repeat procedures as needed for jaw cylinder head end oil tube.

REMOVAL

- | | | | |
|---|---|---|--|
| 1. Loader backhoe | Boom, dipperstick, and bucket | a. Extend as far as possible (TM 5-2420-222-10). | b. Lower to ground so that boom and dipperstick are horizontal (TM 5-2420-222-10). |
| 2. Three clamps (1, 2, and 3), spacer (4), and boom (5) | Screw (6) and lockwasher (7) | a. Using 9/16-inch, 3/8-inch drive socket and ratchet handle, unscrew and take out. | b. Get rid of lockwasher (7). |
| 3. Four tubes (8 thru 11) and boom (5) | Three clamps (1, 2, and 3) and spacer (4) | Take off. | |

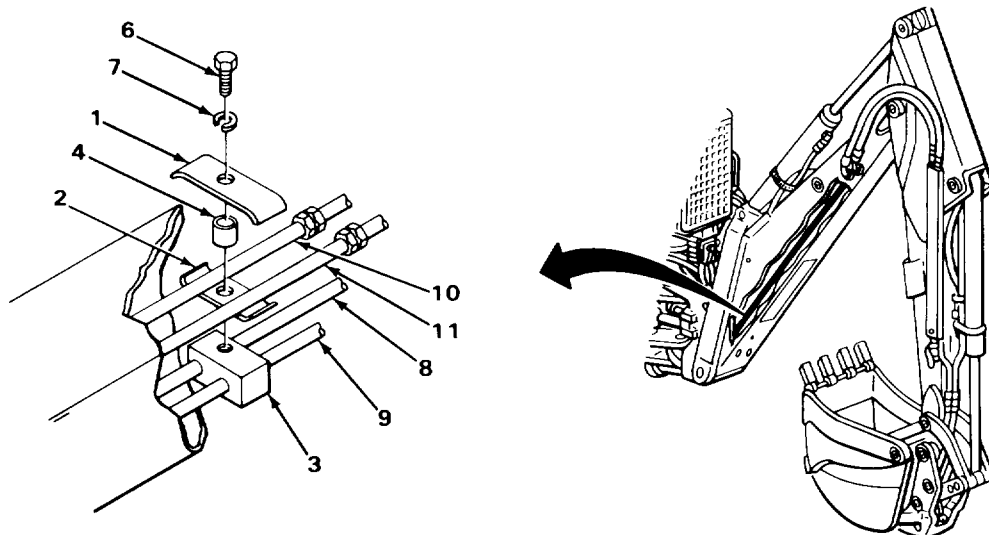

TA243463

**MANIFOLD BLOCK-TO-BOOM JAW CONTROL OIL TUBES (SERIAL NUMBERS 319995 THRU 342573 ONLY)
--CONTINUED**

LOCATION	ITEM	ACTION	REMARKS
----------	------	--------	---------

REMOVAL - CONTINUED

WARNING

Do not attempt to disconnect hydraulic lines and fittings while engine is running or before hydraulic system pressure has been released. When engine is running, hydraulic system is under pressure. Hydraulic system pressure should be 0 psi (0 kPa) before lines are disconnected. A line or fitting disconnected under pressure will blow off with a lot of force and could cause serious injury to personnel.

Be careful when draining hot fluids. Wear gloves to protect your hands from hot parts and fluids or severe burns could result.

- | | | | |
|----|-----------------------|------------|--|
| 4. | Tube (1) | Hose (2) | a. Place drain pan underneath.
b. Using 3/4-inch and 7/8-inch open-end wrenches, unscrew and take off.
c. Tag (page 2-137).
d. Plug (page 2-137). |
| 5. | Tube (1) and hose (3) | Band (4) | a. Using diagonal-cutting pliers, cut off.
b. Get rid of. |
| 6. | Tube (1) | Hose (5) | a. Place drain pan underneath.
b. Using 7/8-inch open-end wrench, unscrew and take off.
c. Tag (page 2-137).
d. Plug (page 2-137).
e. Get rid of drained fluid (page 2-137). |
| 7. | Tube (1) and boom (6) | Jamnut (7) | Using 1 1/8-inch open-end wrench, unscrew and take out. |
| 8. | Boom (6) | Tube (1) | a. Take out.
b. Tag (page 2-137). |

CLEANING

NOTE

For more information on how to clean parts, go to General Maintenance Instructions (page 2-137).

**MANIFOLD BLOCK-TO-BOOM JAW CONTROL OIL TUBES (SERIAL NUMBERS 319995 THRU 342573 ONLY)
--CONTINUED**

LOCATION	ITEM	ACTION	REMARKS
----------	------	--------	---------

WARNING

Drycleaning solvent P-D-680 is toxic and flammable. Wear protective goggles and gloves and use only in a well ventilated area. Avoid contact with skin, eyes, and clothes and don't breathe vapors. Do not use near open flame or excessive heat. The flashpoint is 100°F to 138°F (38° to 59°C). If you become dizzy while using cleaning solvent, get fresh air immediately and get medical aid. If contact with eyes is made, wash your eyes with water and get medical aid immediately.

- | | | |
|-----|-----------------------|---|
| 9. | Tube (1) | a. Using clean rags dampened in drycleaning solvent, wipe clean.
b. Using clean, dry rags, wipe dry. |
| 10. | All other metal parts | a. Clean in drycleaning solvent.
b. Using clean, dry rags, wipe dry. |

INSPECTION/REPLACEMENT

NOTE

For more information on how to inspect parts, go to General Maintenance Instructions (page 2-137). Replace defective parts as needed.

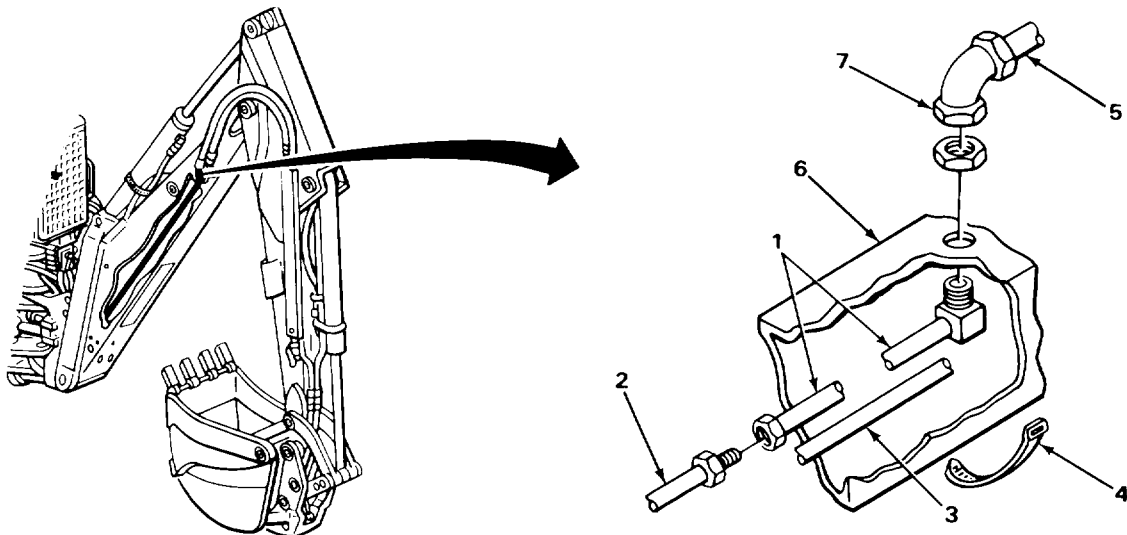

TA243464

**MANIFOLD BLOCK-TO-BOOM JAW CONTROL OIL TUBES (SERIAL NUMBERS 319995 THRU 342573 ONLY)
--CONTINUED**

LOCATION	ITEM	ACTION	REMARKS
INSPECTION/REPLACEMENT - CONTINUED			
11.	All metal parts		Look for cracks, breaks, and abnormal bends.
12.	All threaded parts		Look for damaged threads.
INSTALLATION			
13.	Boom (1) Tube (2)		a. Take off tag. b. Place in position.
14.	Boom (1) and tube (2)	Jamnut (3)	Screw on and tighten using 1 1/8-inch open-end wrench.
15.	Tube (2)	Hose (4)	a. Unplug. b. Take off tag. c. Screw on and tighten using 7/8-inch open-end wrench.
16.	Tube (2) and hose (5)	New band (6)	a. Place in position. b. Using slip-joint pliers, tighten until snug.
17.	Tube (2)	Hose (7)	a. Unplug. b. Take off tag. c. Screw on and tighten using 3/4-inch and 7/8-inch open-end wrenches.
18.	Four tubes (2, 8, 9, and 10) and boom (1)	Three clamps (11, 12, and 13), and spacer (14)	Place in position.
19.	Three clamps (11, 12, and 13), spacer (14), and boom (1)	Screw (15) and new lockwasher (16)	Screw in and tighten using 9/16-inch, 3/8-inch drive socket and ratchet handle.
20.	Loader backhoe	Transmission	Check fluid level and add proper amount and grade (TM 5-2420-222-10).
21.		Engine	Start and run at fast idle (TM 5-2420-222-10).

**MANIFOLD BLOCK-TO-BOOM JAW CONTROL OIL TUBES (SERIAL NUMBERS 31995 THRU 342573 ONLY)
--CONTINUED**

LOCATION	ITEM	ACTION	REMARKS
22.	Manifold block-to-boom jaw control oil tubes	<ul style="list-style-type: none"> a. Operate jaw controls (TM 5-2420-222-10) and check for leaks. b. If leaking at any connection, tighten using 3/4-inch and 7/8-inch open-end wrenches. c. If leaking does not stop, shut down engine (TM 5-2420-222-10) and replace defective tube as outlined in this task. d. If found leaking, repeat steps 20 thru 22. 	
23.	Engine	If still running, shut down (TM 5-2420-222-10).	

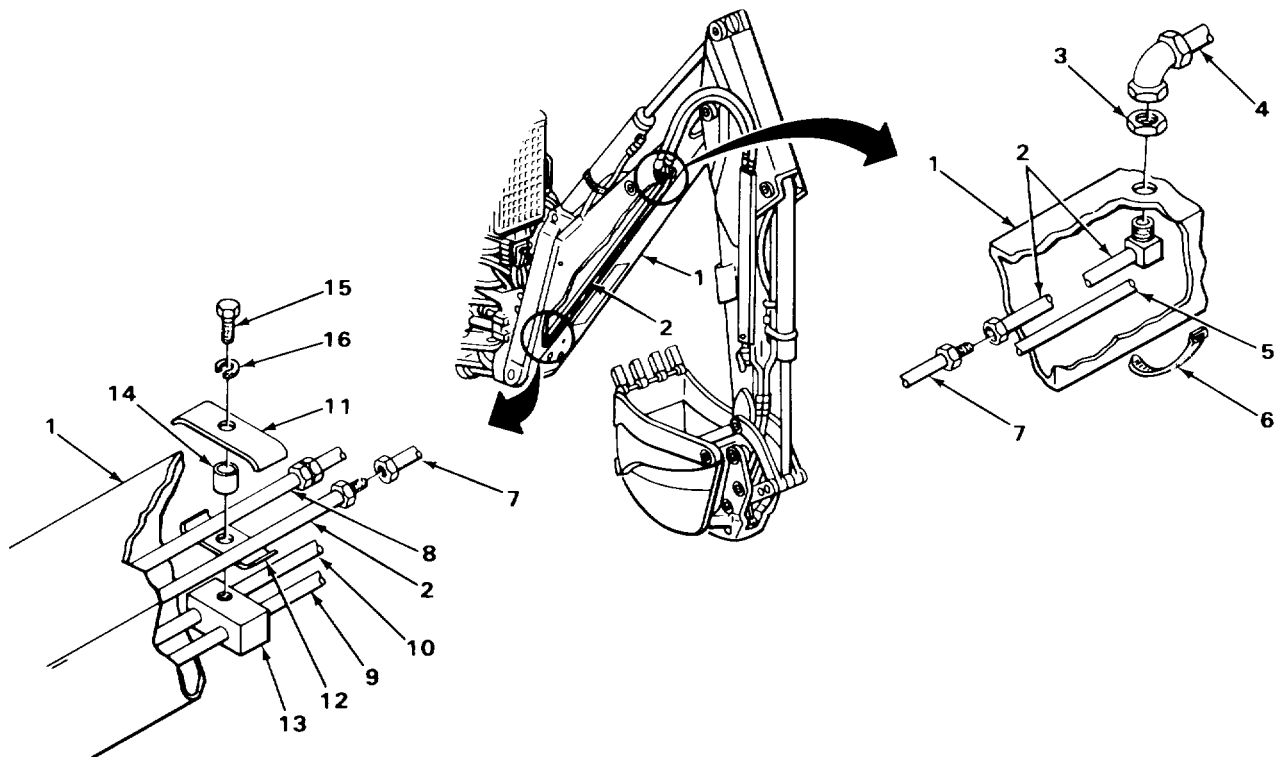

TASK ENDS HERE

BOOM-TO-JAW CYLINDER OIL HOSE OIL LINES (SERIAL NUMBERS 235786 THRU 235999 ONLY)

LOCATION	ITEM	ACTION	REMARKS
----------	------	--------	---------

JAW DIRECT LINEAR VALVE (SERIAL NUMBERS 319995 THRU 342573 ONLY)

This task covers:

- | | |
|---------------------------|---|
| a. Removal (page 2-1532) | c. Inspection/Replacement (page 2-1535) |
| b. Cleaning (page 2-1534) | d. Installation (page 2-1535) |
-

INITIAL SETUP

Tools

- Handle, ratchet, 3/8-inch drive
- Pan, drain
- Socket, 3/8-inch drive, 9/16-inch
- Wrench, open-end, 3/4-inch
- Wrench, open-end, 7/8-inch
- Wrench, open-end, 1-inch

Materials/Parts - Continued

- Solvent, drycleaning (item 28, Appendix C)
- Tags, marking (item 30, Appendix C)

Personnel Required

One

Materials/Parts

- Detergent, GP (item 7, Appendix C)
- Nut, special (clamp stud)
- Rags, wiping (item 21, Appendix C)

Equipment Condition

Hydraulic system pressure released
(page 2-1191)

LOCATION	ITEM	ACTION	REMARKS
----------	------	--------	---------

NOTE

Both boom-to-jaw cylinder oil hose oil lines are maintained the same way. Oil line-to jaw cylinder rod end oil hose is shown. Repeat procedures as needed for jaw cylinder head end oil hose oil line.

REMOVAL

WARNING

Do not attempt to disconnect hydraulic lines and fittings while engine is running or before hydraulic system pressure has been released. When engine is running, hydraulic system is under pressure. Hydraulic system pressure should be 0 psi (0 kPa) before lines are disconnected. A line or fitting disconnected under pressure will blow off with a lot of force and could cause serious injury to personnel.

Be careful when draining hot fluids. Wear gloves to protect your hands from hot parts and fluids or severe burns could result.

BOOM-TO-JAW CYLINDER OIL HOSE OIL LINES (SERIAL NUMBERS 235786 THRU 235999 ONLY) CONTINUED

LOCATION	ITEM	ACTION	REMARKS
1. Hose(1)	Hose (2)	a. Place drain pan underneath. b. Using 7/8-inch and 1-inch open-end wrenches, unscrew and take out. c. Cap (page 2-137). d. Tag (page 2-137).	
2. Tube (3)	Hose (1)	a. Place drain pan underneath. b. Using 3/4-inch and 7/8-inch open-end wrenches, unscrew and take off. c. 1lag (page 2-137).	
3.	Hose (4J)	a. Place drain pan underneath. b. Using 3/4-inch and 7/8-inch open-end wrenches, unscrew and take off. c. Plug (page 2-137). d. Tag (page 2-137). e. Get rid of drained fluid (page 2-137).	

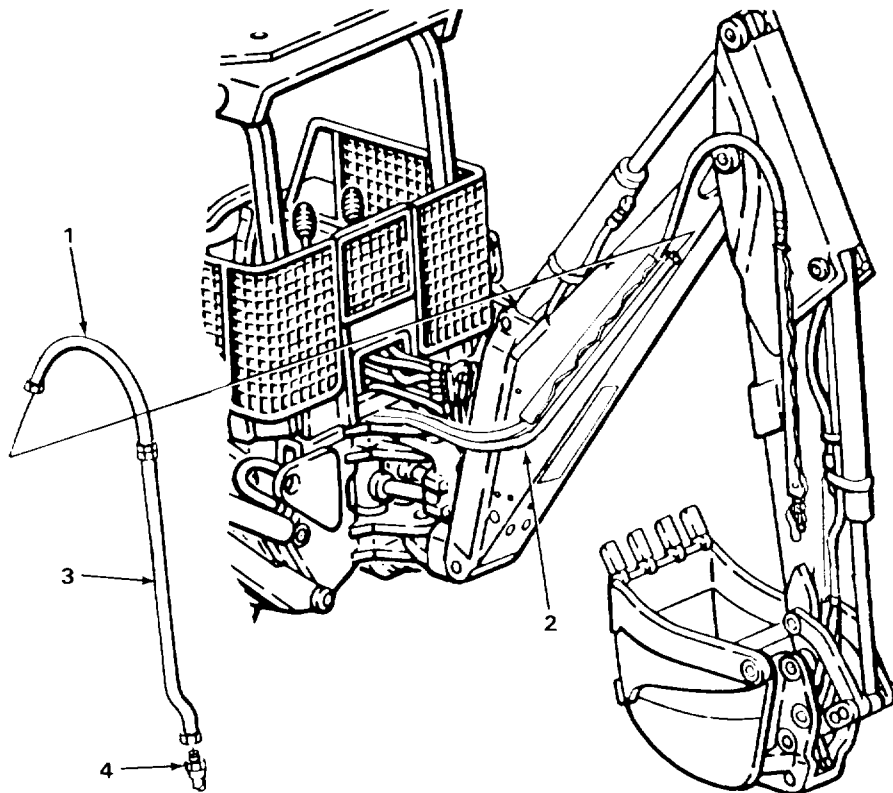

TA243466

BOOM-TO-JAW CYLINDER OIL HOSE OIL LINES (SERIAL NUMBERS 235786 THRU 235999 ONLY) CONTINUED

LOCATION	ITEM	ACTION	REMARKS
REMOVAL - CONTINUED			
4.	Stud (1) and clamp (2)	Special nut (3)	a. Using 9/16-inch, 3/8-inch drive socket and ratchet handle, unscrew and take off. b. Get rid of.
5.	Stud (2), two tubes (4 and 5), and dipperstick (6)	Two clamps (2 and 7)	Take off.
6.	Dipperstick (6) and guard (8)	Tube (4)	a. Slide out. b. Tag (page 2-137).

CLEANING**NOTE**

For more information on how to clean parts, go to **General Maintenance Instructions (page 2-137)**.

- | | | |
|----|----------|---|
| 7. | Hose (9) | a. Using clean rags dampened in solution of detergent and water, wipe clean.
b. Rinse with clean water.
c. Using clean, dry rags, wipe dry. |
|----|----------|---|

WARNING

Drycleaning solvent P-D-680 is toxic and flammable. Wear protective goggles and gloves and use only in a well ventilated area. Avoid contact with skin, eyes, and clothes and don't breathe vapors. Do not use near open flame or excessive heat. The flashpoint is 100°F to 138°F (38° to 59°C). If you become dizzy while using cleaning solvent, get fresh air immediately and get medical aid. If contact with eyes is made, wash your eyes with water and get medical aid immediately.

- | | | |
|----|-----------------------|--|
| 8. | Tube (4) | a. Using clean rags dampened in dry-cleaning solvent, wipe clean.
b. Using clean, dry rags, wipe dry. |
| 9. | All other metal parts | a. Clean in drycleaning solvent.
b. Using clean, dry rags, wipe dry. |

BOOM-TO-JAW CYLINDER OIL HOSE OIL LINES (SERIAL NUMBERS 235786 THRU 235999 ONLY) CONTINUED

LOCATION	ITEM	ACTION	REMARKS
----------	------	--------	---------

INSPECTION/REPLACEMENT

NOTE

For more information on how to inspect parts, go to **General Maintenance Instructions (page 2-137)**.
 Replace defective parts as needed.

- | | | |
|-----|--------------------|--|
| 10. | Hose (9) | Look for cracks, breaks, cuts, and tears. |
| 11. | All metal parts | Look for cracks and breaks and abnormal bends. |
| 12. | All threaded parts | Look for damaged threads. |

INSTALLATION

- | | | | |
|-----|--|----------------------|---|
| 13. | Dipperstick (6)
and guard (8) | Tube (4) | a. Slide into position.
b. Take off tag. |
| 14. | Stud (1), two
tubes (4 and 5),
and dipperstick (6) | Two clamps (2 and 7) | Place in position. |

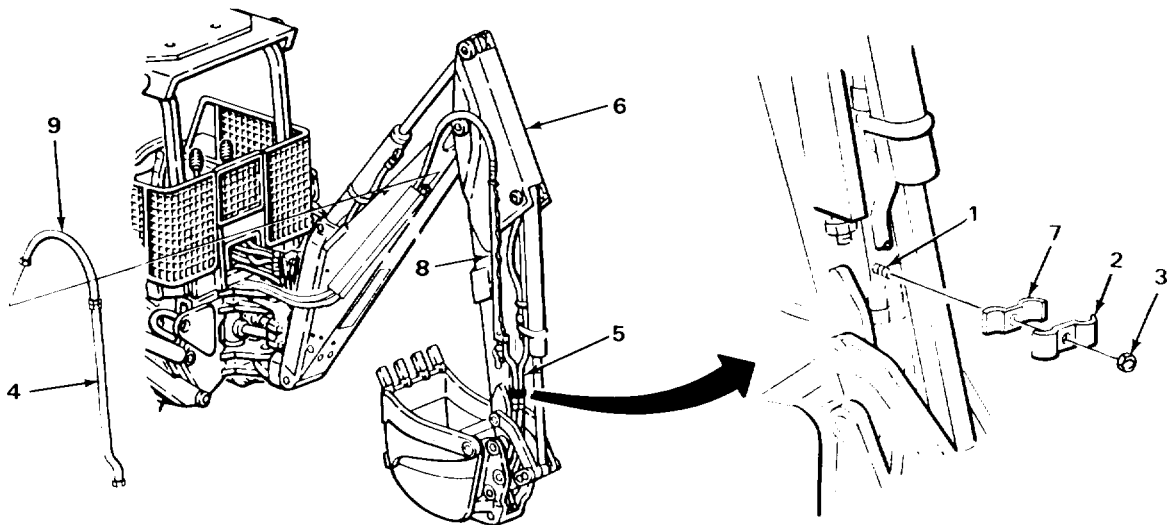

TA243467

BOOM-TO-JAW CYLINDER OIL HOSE OIL LINES (SERIAL NUMBERS 235786 THRU 235999 ONLY) CONTINUED

LOCATION	ITEM	ACTION	REMARKS
INSTALLATION - CONTINUED			
15.	Stud (1) and clamp (2)	New special nut (3)	Screw in and tighten using 9/16-inch, 3/8-inch drive socket and ratchet handle.
16.	Tube (4)	Hose (5)	a. Unplug. b. Take off tag. c. Screw on and tighten using 3/4-inch and 7/8-inch open-end wrenches.
17.	Hose (6)	a. Take off tag.	b. Screw on and tighten using 3/4-inch and 7/8-inch open-end wrenches.
18.	Hose (6)	Hose (7)	a. Uncap. b. Take off tag. c. Screw on and tighten using 7/8-inch and 1-inch open-end wrenches.
19.	Loader backhoe	Transmission	Check fluid level and add proper amount and grade (TM 5-2420-222-10).
20.		Engine	Start and run at high idle (TM 5-2420-222-10).
21.		Boom-to-jaw cylinder oil hose oil lines	a. Operate jaw controls (TM 5-2420-222-10) and check for leaks. b. If leaking at any connection, tighten using 3/4-inch, 7/8-inch, and 1-inch open-end wrenches. c. If leaking does not stop, shut down engine (TM 5-2420-222-10) and replace defective hose or tube as outlined in this task. d. If found leaking, repeat steps 19 thru 21.
22.		Engine	If still running, shut down (TM 5-2420-222-10).

BOOM-TO-JAW CYLINDER OIL HOSE OIL LINES (SERIAL NUMBERS 235786 THRU 235999 ONLY) CONTINUED

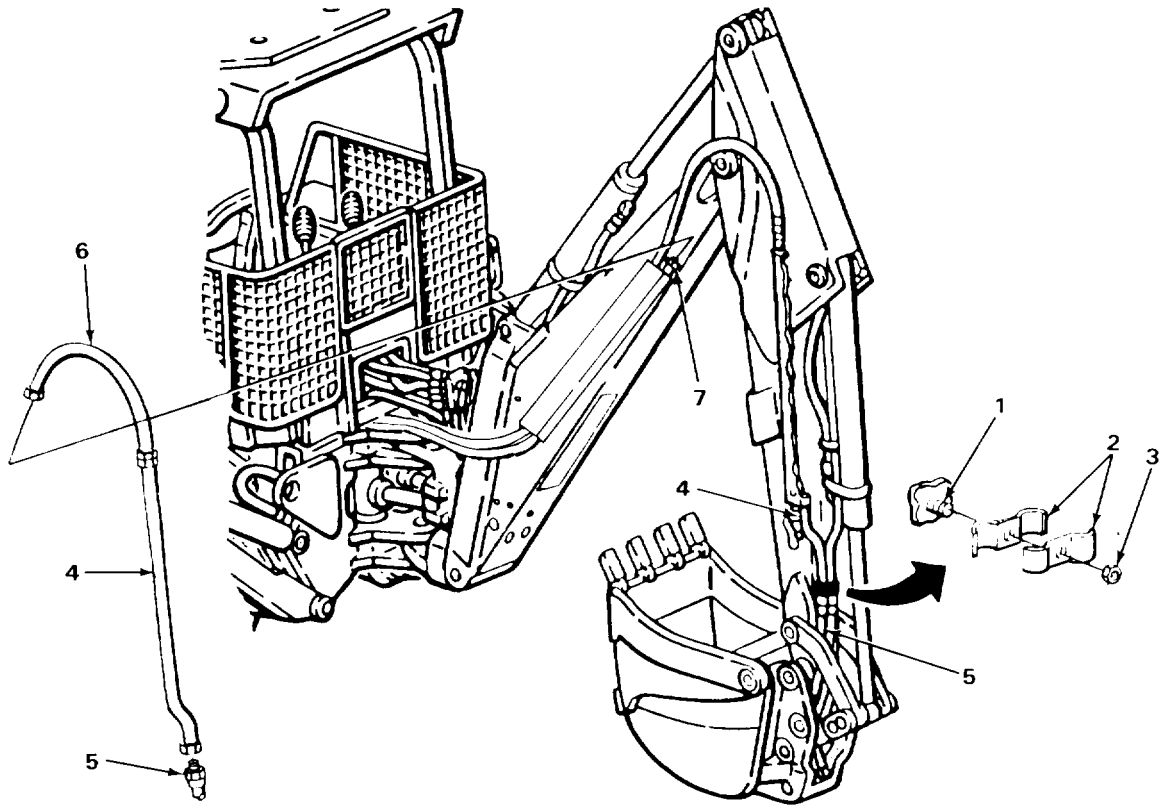

TASK ENDS HERE

BOOM-TO-JAW CYLINDER OIL HOSE OIL LINES (SERIAL NUMBERS 319995 THRU 342573 ONLY)

LOCATION	ITEM	ACTION	REMARKS
----------	------	--------	---------

JAW DIRECT LINEAR VALVE (SERIAL NUMBERS 319995 THRU 342573 ONLY)

This task covers:

- | | |
|------------------------------|---|
| a. Removal (page 2-1538) | d. Inspection/Replacement (page 2-1541) |
| b. Disassembly (page 2-1540) | e. Assembly (page 2-1542) |
| c. Cleaning (page 2-1540) | f. Installation (page 2-1542) |

INITIAL SETUP

Tools

Handle, ratchet, 3/8-inch drive
Pan, drain
Socket, 3/8-inch drive, 9/16-inch
Wrench, open-end, 3/4-inch
Wrench, open-end, 7/8-inch

Materials/Parts

Detergent, GP (item 7, Appendix C)
Lockwasher, guard screw
(two required)
Nut, special

Materials/Parts - Continued

Rags, wiping (item 21, Appendix C)
Solvent, drycleaning (item 28, Appendix C)
Tags, marking (item 30, Appendix C)

Personnel Required

One

Equipment Condition

Hydraulic system pressure released
(page 2-1191)

LOCATION	ITEM	ACTION	REMARKS
----------	------	--------	---------

NOTE

Both boom-to-jaw cylinder oil hose oil lines are maintained the same way. Oil line-to jaw cylinder rod end is shown. Repeat procedures as needed for jaw cylinder head end oil line.

REMOVAL**WARNING**

Do not attempt to disconnect hydraulic lines and fittings while engine is running or before hydraulic system pressure has been released. When engine is running, hydraulic system is under pressure. Hydraulic system pressure should be 0 psi (0 kPa) before lines are disconnected. A line or fitting disconnected under pressure will blow off with a lot of force and could cause serious injury to personnel.

Be careful when draining hot fluids. Wear gloves to protect your hands from hot parts and fluids or severe burns could result.

BOOM-TO-JAW CYLINDER OIL HOSE OIL LINES (SERIAL NUMBERS 319995 THRU 342573 ONLY) - CONTINUED

LOCATION	ITEM	ACTION	REMARKS
1. Tube (1)	Hose (2)	a. Place drain pan underneath. b. Using 7/8-inch open-end wrench, unscrew and take off. c. Tag (page 2-137). d. Cap tube (1) (page 2-137).	
2. Tube (3)	Hose (4)	a. Place drain pan underneath. b. Using 3/4-inch and 7/8-inch open-end wrenches, unscrew and take off. c. Tag (page 2-137). d. Plug (page 2-137). e. Get rid of drained fluid (page 2-137).	
3. Stud (5) and clamp (6)	Special nut (7)	a. Using 9116-inch, 3/8-inch drive socket and ratchet handle, unscrew and take off. b. Get rid of.	
4. Two tubes (3 and 8) and stud (5)	Two clamps (6 and 9)	Take off.	

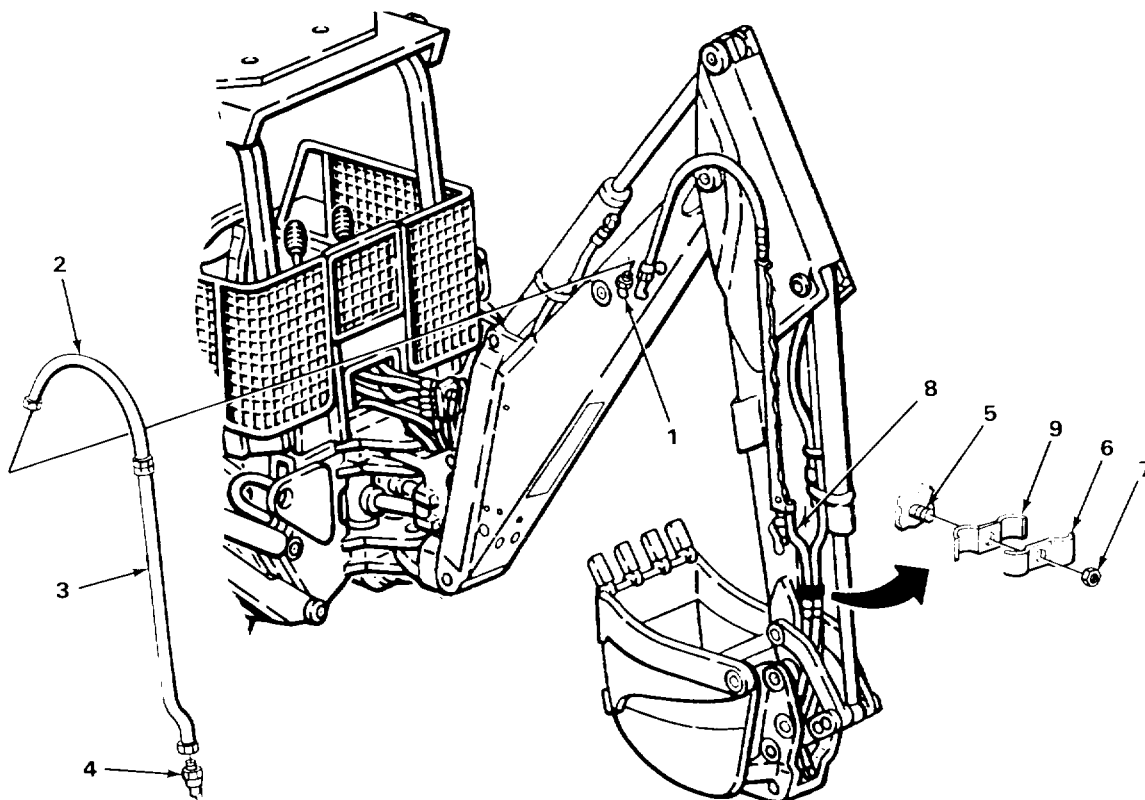

BOOM-TO-JAW CYLINDER OIL HOSE OIL LINES (SERIAL NUMBERS 319995 THRU 342573 ONLY) - CONTINUED

LOCATION	ITEM	ACTION	REMARKS
REMOVAL - CONTINUED			
5.	Guard (1), two clamps (2), and dipperstick (3)	Two screws (4), lockwashers (5), and washers (6)	<ul style="list-style-type: none"> a. Using 9/16-inch, 3/8-inch drive socket and ratchet handle, unscrew and take out. b. Get rid of lockwashers (5).
6.	Two tubes (7 and 8) and dipperstick (3)	Guard (1) and two clamps (2)	Take off.
7.	Dipperstick (3)	Tube (7) with assembled hose (9)	Take off.

DISASSEMBLY

8.	Tube (7)	Hose (9)	<ul style="list-style-type: none"> a. Note relative position for proper placement during installation. b. Using 3/4-inch and 7/8-inch open-end wrenches, unscrew and take off. c. Tag (page 2-137).
----	----------	----------	--

CLEANING**NOTE**

For more information on how to clean parts, go to **General Maintenance Instructions (page 2-137)**.

9.	All rubber parts	<ul style="list-style-type: none"> a. Using clean rags dampened in solution of detergent and water, wipe clean. b. Rinse with clean water. c. Using clean, dry rags, wipe dry.
----	------------------	---

WARNING

Drycleaning solvent P-D-680 is toxic and flammable. Wear protective goggles and gloves and use only in a well ventilated area. Avoid contact with skin, eyes, and clothes and don't breathe vapors. Do not use near open flame or excessive heat. The flashpoint is 100°F to 138°F (38° to 59°C). If you become dizzy while using cleaning solvent, get fresh air immediately and get medical aid. If contact with eyes is made, wash your eyes with water and get medical aid immediately.

10.	Tube (7)	<ul style="list-style-type: none"> a. Using clean rags dampened in dry-cleaning solvent, wipe clean. b. Using clean, dry rags, wipe dry.
-----	----------	--

BOOM-TO-JAW CYLINDER OIL HOSE OIL LINES (SERIAL NUMBERS 319995 THRU 342573 ONLY) - CONTINUED

LOCATION	ITEM	ACTION	REMARKS
11.	All other metal	a. Clean in drycleaning solvent. b. Using clean, dry rags, wipe dry.	

INSPECTION/REPLACEMENT

NOTE

For more information on how to inspect parts, go to **General Maintenance Instructions (page 2-137)**.

Replace defective parts as needed.

- | | | |
|-----|--------------------|--|
| 12. | Hose (9) | Look for cracks, breaks, cuts, and tears. |
| 13. | All metal parts | Look for cracks and breaks and abnormal bends. |
| 14. | All threaded parts | Look for damaged threads. |

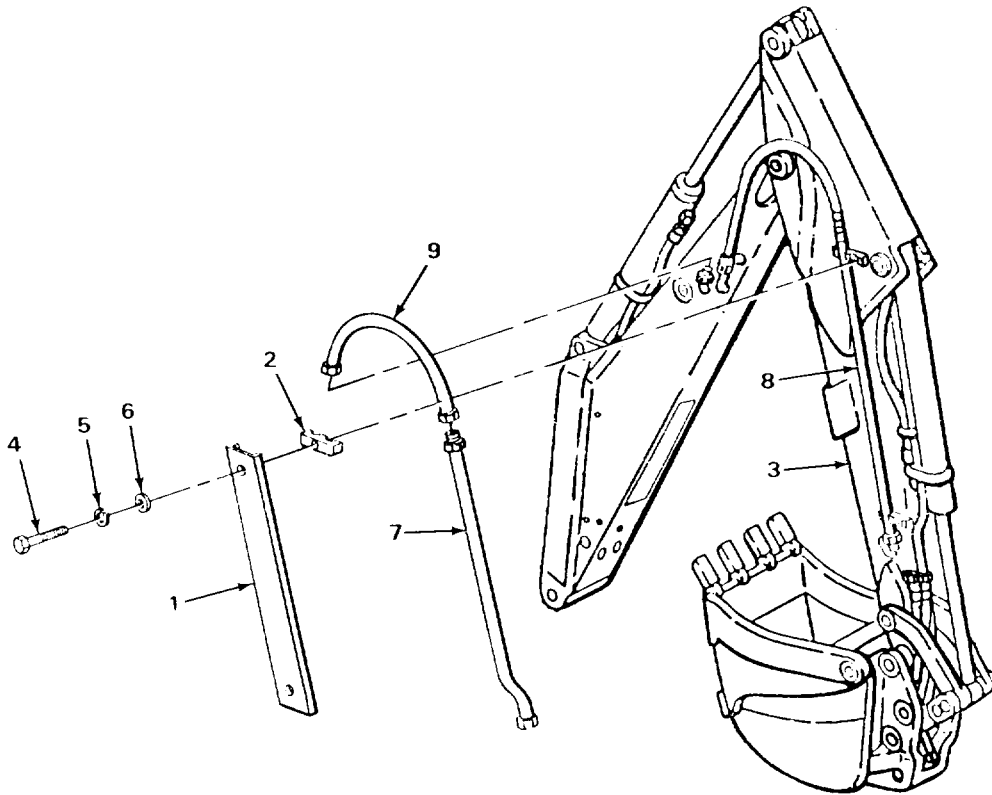

TA243470

BOOM-TO-JAW CYLINDER OIL HOSE OIL LINES (SERIAL NUMBERS 319995 THRU 342573 ONLY) - CONTINUED

LOCATION	ITEM	ACTION	REMARKS
ASSEMBLY			
15.	Tube (1)	Hose (2)	a. Take off tag. b. Screw on and tighten to same relative position noted during removal using 3/4-inch and 7/8-inch open-end wrenches.
INSTALLATION			
16.	Dipperstick (3)	Tube (1) with assembled hose (2)	Place in position.
17.	Dipperstick (3) and two tubes (1 and 4)	Guard (5) and two clamps (6)	Place in position.
18.	Guard (5), two clamps (6), and dipperstick (3)	Two screws (7), washers (8), and new lockwashers (9)	Screw in and tighten using 9/16-inch, 3/8-inch drive socket and ratchet handle.
19.	Two tubes (1 and 10) and stud (11)	Two clamps (12 and 13)	Place in position.
20.	Stud (11) and clamp (12)	New special nut (14)	Screw in and tighten using 9/16-inch, 3/8-inch drive socket and ratchet handle.
21.	Tube (1)	Hose (15)	a. Unplug. b. Take off tag. c. Screw on and tighten using 3/4-inch and 7/8 inch open-end wrenches.
22.	Tube (16)	Hose (2)	a. Uncap tube (16). b. Take off tag. c. Screw on and tighten using 7/8 inch open-end wrench.
23.	Loader backhoe	Transmission	Check fluid level and add proper amount and grade (TM 5-2420-222-10).
24.		Engine	Start and run at high idle (TM 5-2420-222-10).

BOOM-TO-JAW CYLINDER OIL HOSE OIL LINES (SERIAL NUMBERS 319995 THRU 342573 ONLY) - CONTINUED

LOCATION	ITEM	ACTION REMARKS
25.	Boom-to-jaw cylinder oil hose oil line	a. Operate jaw controls (TM 5-2420-222-10) and check for leaks. b. If leaking at any connection, tighten using 3/4-inch and 7/8-inch open-end wrenches. c. If leaking does not stop, shut down engine (TM 5-2420-222-10) and replace defective tube or hose as outlined in this task. d. If found leaking, repeat steps 23 thru 25.
26.	Engine	If still running, shut down (TM 5-2420-222-10).

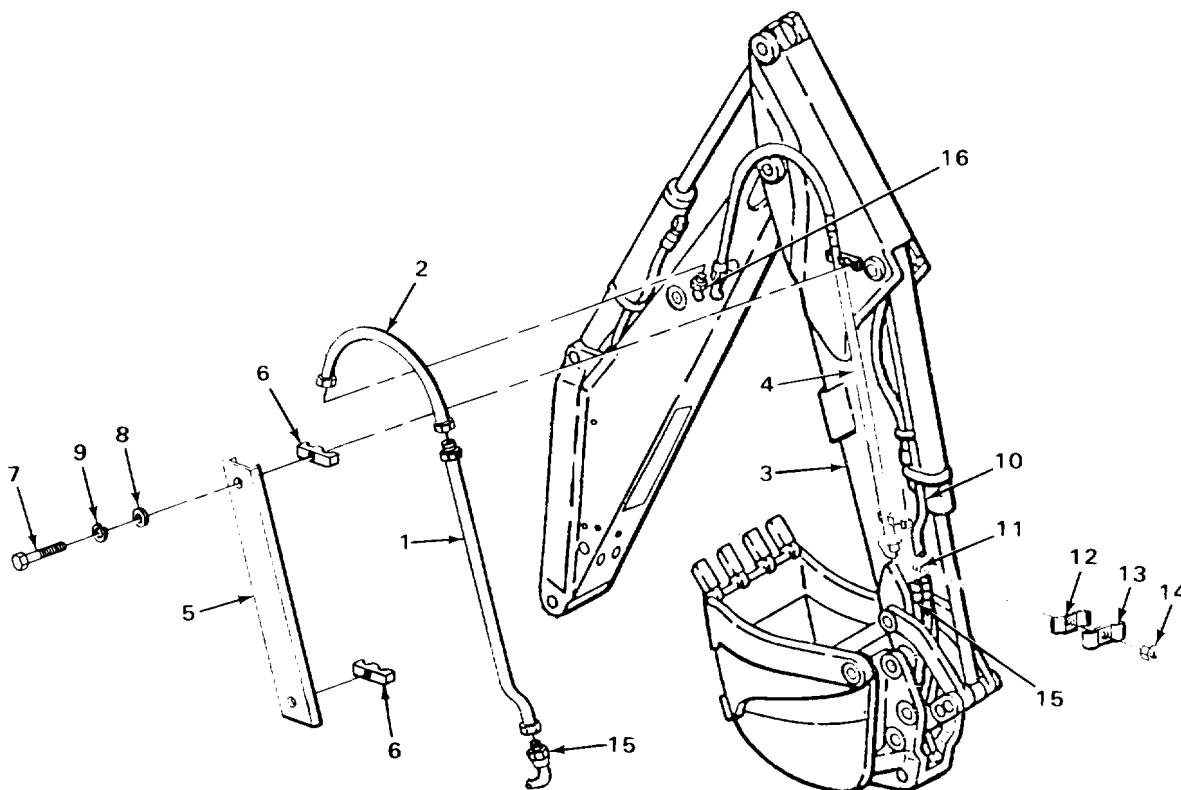

TASK ENDS HERE

JAW CYLINDER OIL HOSES

This task covers:

- a. Removal (page 2-1544)
 - b. Cleaning (page 2-1546)
 - c. Inspection/Replacement (page 2-1547)
 - d. Installation (page 2-1547)
-

INITIAL SETUP

Tools

- Knife, pocket
- Pan, drain
- Wrench, open-end, 11/16-inch
(two required)
- Wrench, open-end, 3/4-inch
- Wrench, open-end, 7/8-inch

Materials/Parts

- Detergent, GP (item 7, Appendix C)
- Packing, elbow

Materials/Parts - Continued

- Rags, wiping (item 21, Appendix C)
- Solvent, drycleaning (item 28, Appendix C)
- Tags, marking (item 30, Appendix C)

Personnel Required

One

Equipment Condition

Hydraulic system pressure released
(page 2-1191)

LOCATION	ITEM	ACTION	REMARKS
----------	------	--------	---------

NOTE

Both jaw cylinder oil hoses are maintained the same way except as noted. Jaw cylinder head end oil hose is shown. Repeat procedures as needed for jaw cylinder head end oil hose.

REMOVAL

WARNING

Do not attempt to disconnect hydraulic lines and fittings while engine is running or before hydraulic system pressure has been released. When engine is running, hydraulic system is under pressure. Hydraulic system pressure should be 0 psi (0 kPa) before lines are disconnected. A line or fitting disconnected under pressure will blow off with a lot of force and could cause serious injury to personnel.

Be careful when draining hot fluids. Wear gloves to protect your hands from hot parts and fluids or severe burns could result.

JAW CYLINDER OIL HOSES - CONTINUED

LOCATION	ITEM	ACTION REMARKS
1. Tube (1)	Hose (2)	a. Place drain pan underneath. b. Using 3/4-inch and 7/8-inch open-end wrenches, unscrew and take off. c. Cap tube (1) (page 2-137). d. Tag (page 2-137).
2. Spacer (3)	Hose (2)	a. Note routing for proper placement during installation. b. Uncoil and take off.

NOTE

If removing jaw cylinder rod end oil hose, skip step 3.

3. Cylinder barrel (4)	Hose (2)	a. Place drain pan underneath. b. Using 11/16-inch open-end wrench, unscrew and take out. c. Tag (page 2-137). d. Plug cylinder barrel (4) (page 2-137). e. Get rid of drained fluid (page 2-137).
------------------------	----------	--

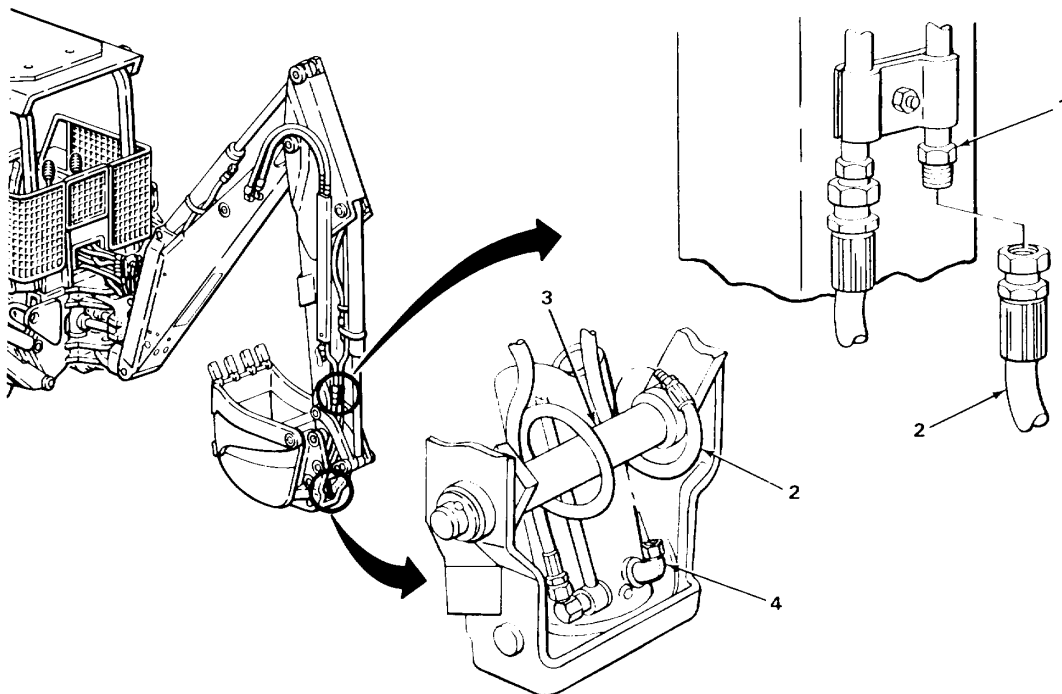

TA243472

JAW CYLINDER OIL HOSES - CONTINUED

LOCATION	ITEM	ACTION	REMARKS
REMOVAL - CONTINUED			
NOTE			
If removing jaw cylinder rod end oil hose, skip step 4 thru 7.			
4. Elbow (1)	Hose (2)	a. Place drain pan underneath. b. Using two 11/16-inch open-end wrenches, unscrew and take off. c. Tag (page 2-137).	
5. Cylinder barrel (3) and elbow (1)	Nut (4)		Using two 11/16-inch open-end wrenches, loosen.
6. Cylinder barrel (3)	Elbow (1) with assembled parts	a. Note relative position for proper placement during installation. b. Using 11/16-inch open-end wrench, unscrew and take out. c. Plug barrel (3) (page 2-137).	
7. Elbow (1)	Packing (5)	a. Using pocket knife, take off. b. Get rid of.	

CLEANING

NOTE

For more information on how to clean parts, go to General Maintenance Instructions (page 2-137).

8.	Hose (2)	a. Using clean rags dampened in solution of detergent and water, wipe clean. b. Rinse with clean water. c. Using clean, dry rags, wipe dry.	
----	----------	---	--

WARNING

Drycleaning solvent PD680 is toxic and flammable. Wear protective goggles and gloves and use only in a well ventilated area. Avoid contact with skin, eyes, and clothes and don't breathe vapors. Do not use near open flame or excessive heat. The flashpoint is 100°F to 1380F (38° to 59°C). If you become dizzy while using cleaning solvent, get fresh air immediately and get medical aid. If contact with eyes is made, wash your eyes with water and get medical aid immediately.

JAW CYLINDER OIL HOSES - CONTINUED

LOCATION	ITEM	ACTION	REMARKS
9.	All metal parts	a. Clean in drycleaning solvent. b. Using clean, dry rags, wipe dry.	

INSPECTION/REPLACEMENT

NOTE

For more information on how to inspect parts, go to General Maintenance Instructions (page 2-137).

Replace defective parts as needed.

10.	Hose (2)	Look for cracks, breaks, cuts, and tears.
11.	All metal parts	Look for cracks and breaks.
12.	All threaded parts	Look for damaged threads.

INSTALLATION

NOTE

If installing jaw cylinder head end oil hose, skip steps 13 thru 17.

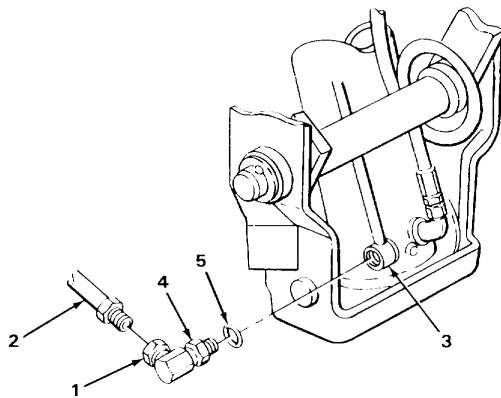

TA243473

JAW CYLINDER OIL HOSES - CONTINUED

LOCATION	ITEM	ACTION REMARKS
INSTALLATION - CONTINUED		
13. Elbow (1)	Nut (2)	Screw on all the way.
14.	New packing (3)	Place in position.
15. Cylinder barrel (4)	Elbow (1) with assembled parts	a. Unplug barrel (4). b. Screw in and tighten to same relative position noted during removal using 11/16-inch open-end wrench.
16. Cylinder barrel (4) and elbow (1)	Nut (2)	Using two 11/16-inch open-end wrenches, tighten until seated against barrel (4).
17. Elbow (1)	Hose (5)	a. Take off tag. b. Screw in and tighten using two 11/16-inch open-end wrenches.
NOTE		
If installing jaw cylinder rod end oil hose, skip step 18.		
18. Cylinder barrel (4)	Hose (5)	a. Uncap barrel (4). b. Take off tag. c. Screw in and tighten using 11/16-inch open-end wrench.
19. Spacer (6)	Hose (5)	Wrap around using same routing noted during removal.
20. Tube (7)	Hose (5)	a. Uncap tube (7). b. Take off tag. c. Screw in and tighten using 3/4-inch and 7/8-inch open-end wrenches.
21. Loader backhoe	Transmission	Check fluid level and add proper amount and grade (TM 5-2420-222-10).
22.	Engine	Start and run at high idle (TM 5-2420-222-10).
23.	Jaw cylinder oil hoses	a. Operate jaw controls (TM 5-2420-222-10) and check for leaks. b. If leaking at any connection, tighten using one or two 11/16-inch, 3/4-inch and 7/8-inch open-end wrenches.

JAW CYLINDER OIL HOSES - CONTINUED

LOCATION	ITEM	ACTION	REMARKS
23. Continued		c. If leaking does not stop, shut down engine (TM 5-2420-222-10) and replace defective packing, fitting, or hose as outlined in this task. d. If found leaking, repeat steps 21 thru 23.	
24.	Engine	If still running, shut down (TM 5-2420-222-10).	

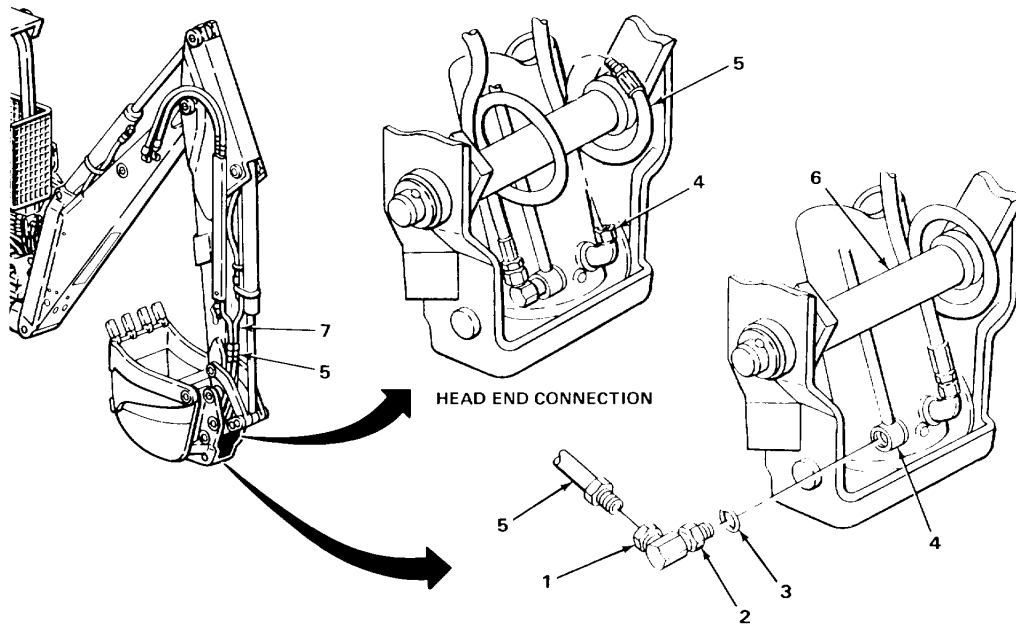

TASK ENDS HERE

HYDRAULIC EARTH DRILL BLEED OIL LINE

This task covers:

- a. Removal (page 2-1550)
 - b. Disassembly (page 2-1552)
 - c. Cleaning (page 2-1552)
 - d. Inspection/Replacement (page 2-1554)
 - e. Assembly (page 2-1554)
 - f. Installation (page 2-1554)
-

INITIAL SETUP

Tools

- Handle, ratchet, 318-inch drive
- Pan, drain
- Pliers, diagonal-cutting
- Pliers, slip-joint
- Socket, 318-inch drive, 9/16-inch
- Wrench, open-end, 9 1/16-inch
- Wrench, open-end, 1 1/16-inch
- Wrench, open-end, 3/4-inch
- Wrench, open-end, 1 1/8-inch

Materials/Parts

- Band

Materials/Parts - Continued

- Detergent, GP (item 7, Appendix C)
- Nut, special
- Rags, wiping (item 21, Appendix C)
- Solvent, drycleaning (item 28, Appendix C)
- Strap, electrical tiedown (item 29, Appendix C) (as required)
- Tags, marking (item 30, Appendix C)
- Tape, lacing and tying (item 33, Appendix C)

Personnel Required

- Two
-

LOCATION	ITEM	ACTION	REMARKS
----------	------	--------	---------

REMOVAL

- | | | | |
|-------------------|-------------------------------|--|--|
| 1. Loader backhoe | Boom, dipperstick, and bucket | a. Extend as far as possible (TM 5-2420-222-10).
b. Lower to ground so that boom and dipperstick are horizontal (TM 5-2420-222-10). | |
|-------------------|-------------------------------|--|--|

WARNING

Be careful when draining hot fluids. Wear gloves to protect your hands from hot parts and fluids or severe burns could result.

- | | | | |
|----------------|-----------|---|--|
| 2. Elbow (1) | Hose (2) | a. Place drain pan underneath.
b. Using 9/16-inch and 11/16-inch open-end wrenches, unscrew and take out.
c. Tag (page 2-137).
d. Get rid of drained fluid (page 2-137). | |
| 3. Adapter (3) | Elbow (1) | a. Note relative position for proper placement during assembly. | |

HYDRAULIC EARTH DRILL BLEED OIL LINE - CONTINUED

LOCATION	ITEM	ACTION REMARKS
3. Continued		b. Using 1 1/8-inch and 1 1/8-inch open-end wrenches, unscrew and take out.
4. Transmission case (4)	Adapter (3)	a. Using 1 1/8-inch open-end wrench, unscrew and take out. b. Plug transmission case (4) (page 2-137).
5. Bracket (5) and clamp (6)	Screw (7) and special nut (8)	a. Using 9/16-inch, 3/8-inch drive socket, ratchet handle, and 9/16-inch open-end wrench, unscrew and take apart. b. Get rid of special nut (8).

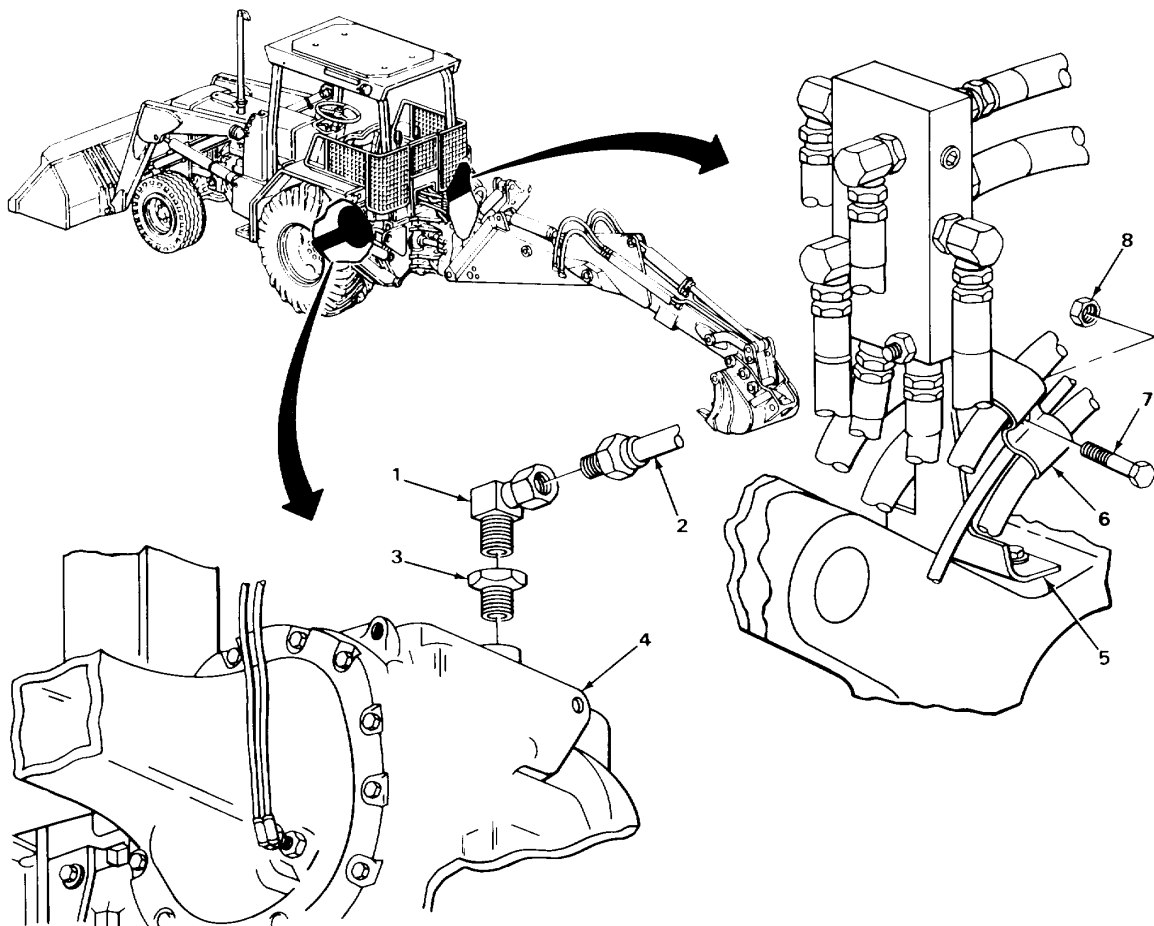

TA243475

HYDRAULIC EARTH DRILL BLEED OIL LINE - CONTINUED

LOCATION	ITEM	ACTION	REMARKS
REMOVAL - CONTINUED			
6.	Bracket (1), two hoses (2 and 3), and isolator (4)	Clamp (5)	Take off.
7.	Bracket (1)	Hose (2)	Take off.
8.	Nine hoses (2, 3, and 6 thru 12)	Band (13)	a. Using diagonal-cutting pliers, cut off. b. Get rid of.
9.	Hose (14)	Hose (2)	a. Using 9116-inch and 11116-inch open-end wrenches, unscrew and take off. b. Tag (page 2-137).
10.	Backhoe frame (15)	Hose (2)	Noting routing, pull out.
11.	Hose (14) and tube (16)	Electrical tiedown strap (17)	a. Note quantity and relative position for proper placement during installation. b. Using diagonal-cutting pliers, cut off. c. Get rid of.
12.	Boom (18) and dipperstick (19)	Hose (14) with assembled parts	a. Attach 20-foot length of lacing and tying tape. b. With aid of assistant, pull out. c. Take off lacing and tying tape leaving it in place to aid in installation.
DISASSEMBLY			
13.	Hose (2)	Adapter (20)	Using 9/16-inch and 3/4-inch open-end wrenches, unscrew and take off.
14.	Coupling (21)	Plug (22)	Pull off.
15.	Hose (14)	Coupling (21)	Using 9/16-inch and 3/4-inch open-end wrenches, unscrew and take off.

CLEANING**NOTE**

For more information on how to clean parts, go to **General Maintenance Instructions (page 2-137)**.

HYDRAULIC EARTH DRILL BLEED OIL LINE - CONTINUED

LOCATION	ITEM	ACTION REMARKS
16.	Hose (2 and 14)	a. Using clean rags dampened in solution of detergent and water, wipe clean. b. Rinse with clean water. c. Using clean, dry rags, wipe dry.

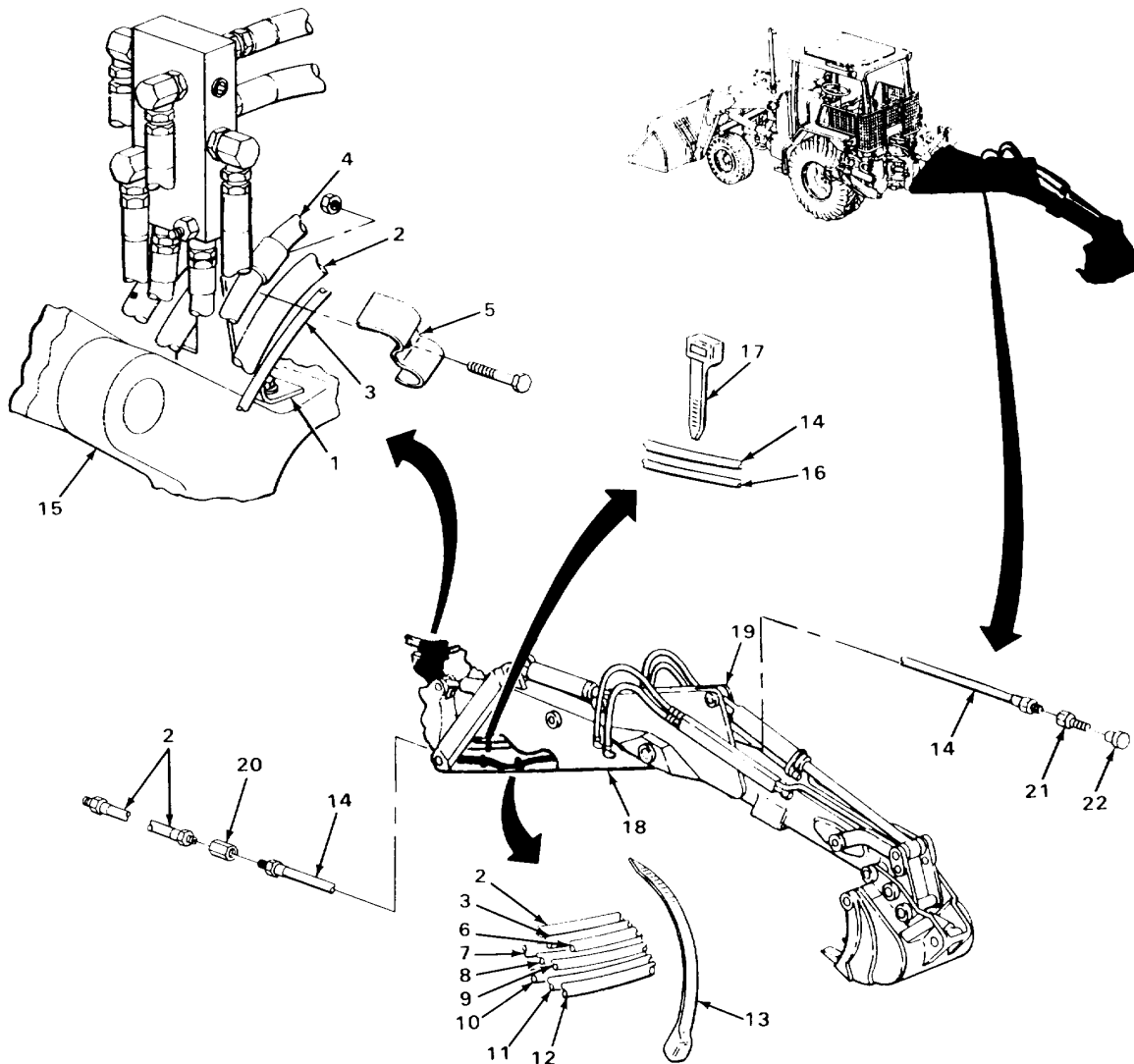

TA243476

HYDRAULIC EARTH DRILL BLEED OIL LINE - CONTINUED

LOCATION	ITEM	ACTION	REMARKS
----------	------	--------	---------

CLEANING - CONTINUED

WARNING

Drycleaning solvent P-D-680 is toxic and flammable. Wear protective goggles and gloves and use only in a well ventilated area. Avoid contact with skin, eyes, and clothes and don't breathe vapors. Do not use near open flame or excessive heat. The flashpoint is 1000F to 1380F (380 to 590C). If you become dizzy while using cleaning solvent, get fresh air immediately and get medical aid. If contact with eyes is made, wash your eyes with water and get medical aid immediately.

- | | | | |
|-----|-----------------|---|--|
| 17. | All metal parts | a. Clean in drycleaning solvent.
b. Using clean, dry rags, wipe dry. | |
|-----|-----------------|---|--|

INSPECTION/REPLACEMENT

NOTE

For more information on how to inspect parts, go to **General Maintenance Instructions (page 2-137)**.

Replace defective parts as needed.

- | | | | |
|-----|---------------------|---|--|
| 18. | Two hoses (1 and 2) | Look for cracks, breaks, cuts, and tears. | |
| 19. | All metal parts | Look for cracks and breaks. | |
| 20. | All threaded parts | Look for damaged threads. | |

ASSEMBLY

- | | | | |
|------------------|--------------|--|--|
| 21. Hose (1) | Coupling (3) | Screw on and tighten using 9/16-inch and 3/4-inch open-end wrenches. | |
| 22. Coupling (3) | Plug (4) | Place in position. | |
| 23. Hose (2) | Adapter (5) | Screw on and tighten using 9/16-inch and 3/4-inch open-end wrenches. | |

INSTALLATION

- | | | | |
|----------------------------------|-------------------------------|---|--|
| 24. Boom (6) and dipperstick (7) | Hose (1) with assembled parts | a. Attach lacing and tying tape.
b. With aid of assistant, pull into position.
c. Take off lacing and tying tape. | |
|----------------------------------|-------------------------------|---|--|

HYDRAULIC EARTH DRILL BLEED OIL LINE - CONTINUED

LOCATION	ITEM	ACTION REMARKS
25. Hose (1) and tube (8)	New electrical tiedown straps (9)	a. Place same quantity in same relative positions noted during removal. b. Using slip-joint pliers, tighten.
26. Backhoe frame	Hose (2)	Using same routing noted during removal, place in position.
27. Hose (1)	Hose (2)	a. Screw in and tighten using 9/16-inch and 11/16-inch open-end wrenches. b. Take off tag.
28. Nine hoses (2 and 10 thru 17)	New band (18)	a. Place in position. b. Using slip-joint pliers, tighten.

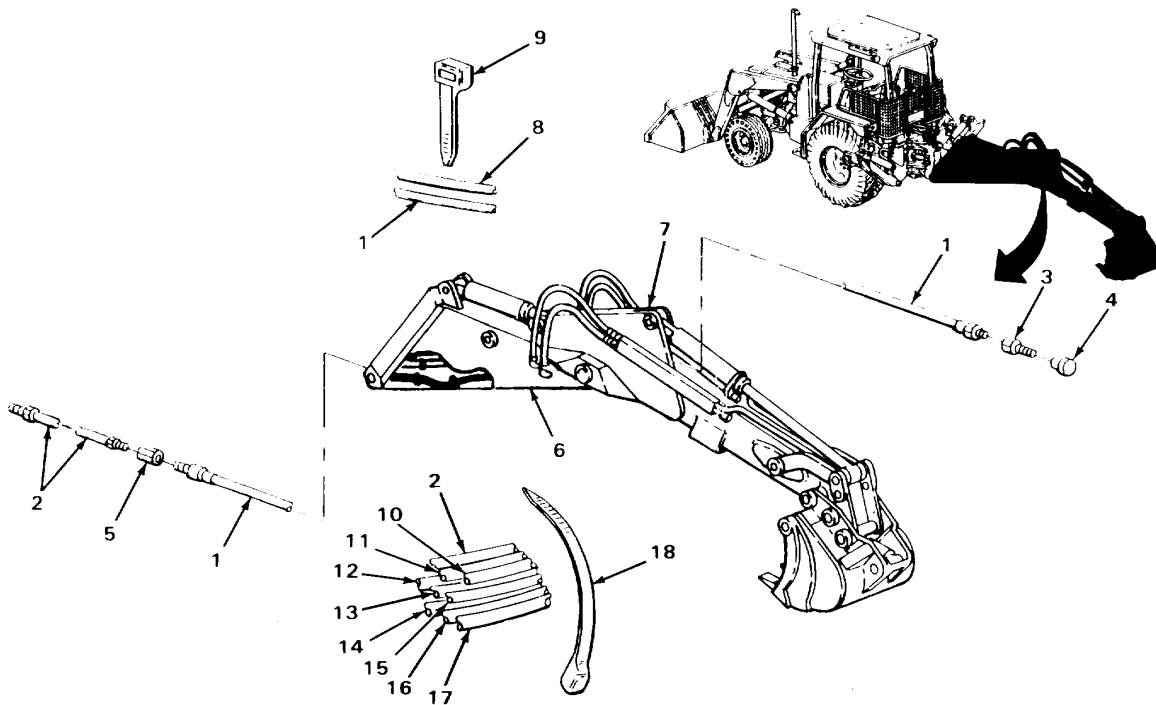

TA243477

HYDRAULIC EARTH DRILL BLEED OIL LINE - CONTINUED

LOCATION	ITEM	ACTION REMARKS
INSTALLATION - CONTINUED		
29. Bracket (1)	Hose (2)	Place in position.
30. Bracket (1), two hose (2 and 3), and isolator (4)	Clamp (5)	Place in position.
31. Bracket (1) and clamp (5)	Screw (6) and new special nut (7)	Screw together and tighten using 9/16-inch, 3/8-inch drive socket, ratchet handle, and 9/16-inch open-end wrench.
32. Transmission case (8)	Adapter (9)	<ul style="list-style-type: none"> a. Unplug transmission case (8). b. Screw in and tighten using 1 1/8-inch open-end wrench.
33. Adapter (9)	Elbow (10)	Screw in and tighten to same relative position noted during removal using 11/16-inch open-end wrench.
34. Elbow (10)	Hose (2)	<ul style="list-style-type: none"> a. Take off tag. b. Screw in and tighten using 9/16-inch and 11/16-inch open-end wrenches.

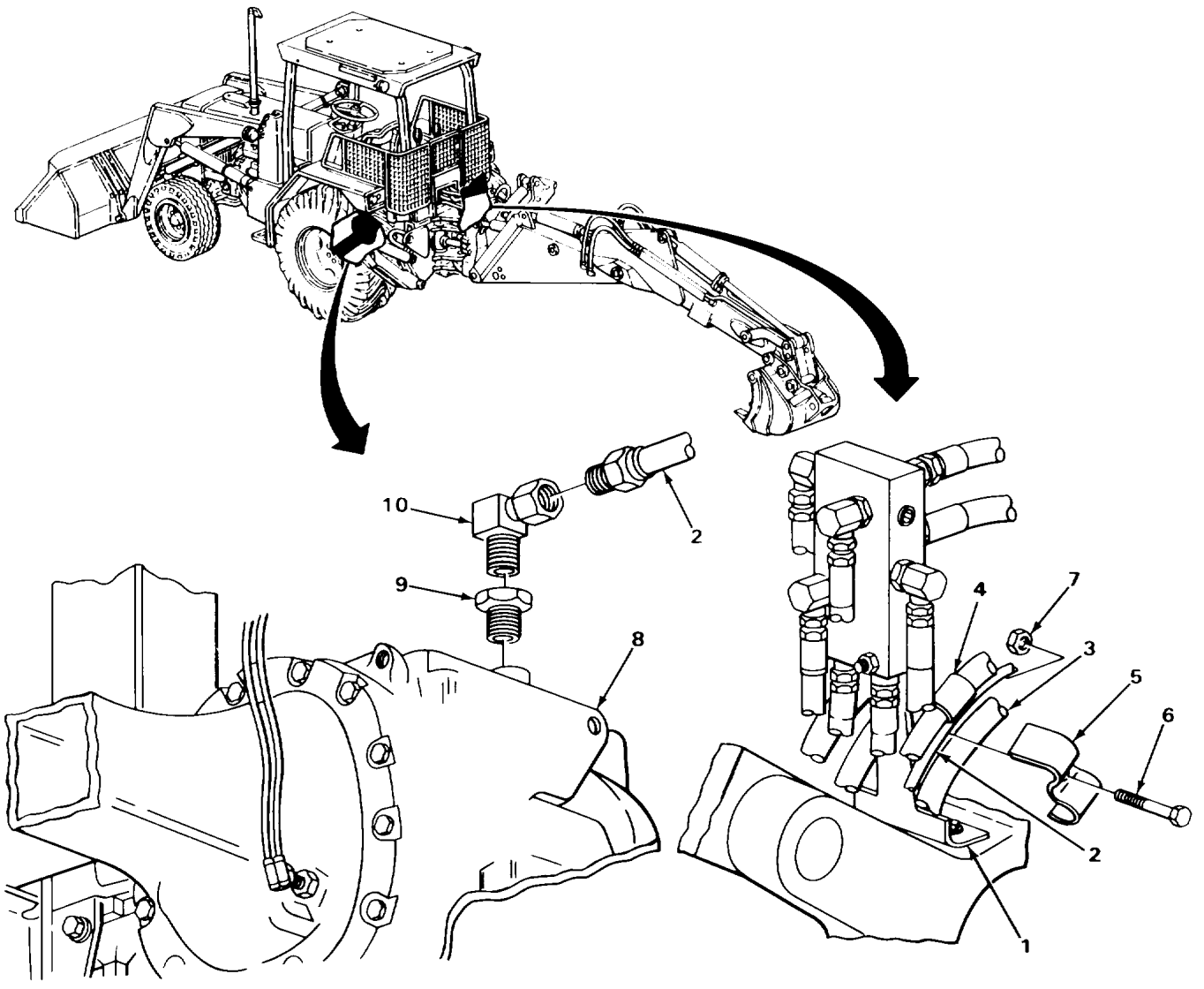

TASK ENDS HERE

TA243478

BACKHOE CONTROL VALVE-TO-MANIFOLD BLOCK OIL LINES

This task covers:

- a. Removal (page 2-1558)
 - b. Cleaning (page 2-1560)
 - c. Inspection/Replacement (page 2-1560)
 - d. Installation (page 2-1561)
-

INITIAL SETUP

Tools

Extension, 1/2-inch drive,
10-inch
Handle, ratchet, 1/2-inch drive
Knife, pocket
Pan, drain
Socket, deep, 1/2-inch drive, 1-inch
Wrench, open-end, 11/16-inch
Wrench, open-end, 3/4-inch
Wrench, open-end, 7/8-inch
Wrench, open-end, 15/16-inch
Wrench, open-end, 1-inch

Materials/Parts

Detergent, GP (item 7, Appendix C)
Packing, straight adapter
(six required)

Materials/Parts

Packing, union adapter (six required)
Rags, wiping (item 21, Appendix C)
Solvent, drycleaning (item 28, Appendix C)
Tags, marking (item 30, Appendix C)

Personnel Required

One

Equipment Condition

1. Backhoe valve box cover removed (page 2-1157)
2. Hydraulic system pressure released (page 2-1191)

LOCATION	ITEM	ACTION	REMARKS
----------	------	--------	---------

NOTE

All six backhoe control valve-to-manifold block oil lines are maintained in same way except as noted. One is shown. Repeat procedures as needed for other five lines. It may be necessary to remove one line to gain access to other lines.

REMOVAL

WARNING

Do not attempt to disconnect hydraulic lines and fittings while engine is running or before hydraulic system pressure has been released. When engine is running, hydraulic system is under pressure. Hydraulic system pressure should be 0 psi (0 kPa) before lines are disconnected. A line or fitting disconnected under pressure will blow off with a lot of force and could cause serious injury to personnel.

Be careful when draining hot fluids. Wear gloves to protect your hands from hot parts and fluids or severe burns could result.

BACKHOE CONTROL VALVE-TO-MANIFOLD BLOCK OIL LINES - CONTINUED

LOCATION	ITEM	ACTION	REMARKS
----------	------	--------	---------

NOTE

Perform step 1 when maintaining lower backhoe crowd valve-to-manifold block oil line. Skip step 1 when maintaining other five lines.

- | | | |
|----------------------|--|--|
| 1. Union adapter (1) | Hose (2) | <ul style="list-style-type: none"> a. Place drain pan underneath. b. Using 11/16-inch and 7/8-inch open-end wrenches, unscrew and take off. c. Cap (page 2-137). d. Tag (page 2-137). e. Plug adapter (1) (page 2-137). |
| 2. Union adapter (3) | Hose (4) | <ul style="list-style-type: none"> a. Using 7/8-inch and 1-inch open-end wrenches, unscrew and take off. b. Tag (page 2-137). |
| 3. Valve (5) | Union adapter (3) with assembled packing (6) | <ul style="list-style-type: none"> a. Using 1-inch, 1/2-inch drive deep socket, 10-inch extension, and ratchet handle, unscrew and take out. b. Plug valve (5) (page 2-137). |
| 4. Union adapter (3) | Packing (6) | <ul style="list-style-type: none"> a. Using pocket knife, take off. b. Get rid of. |

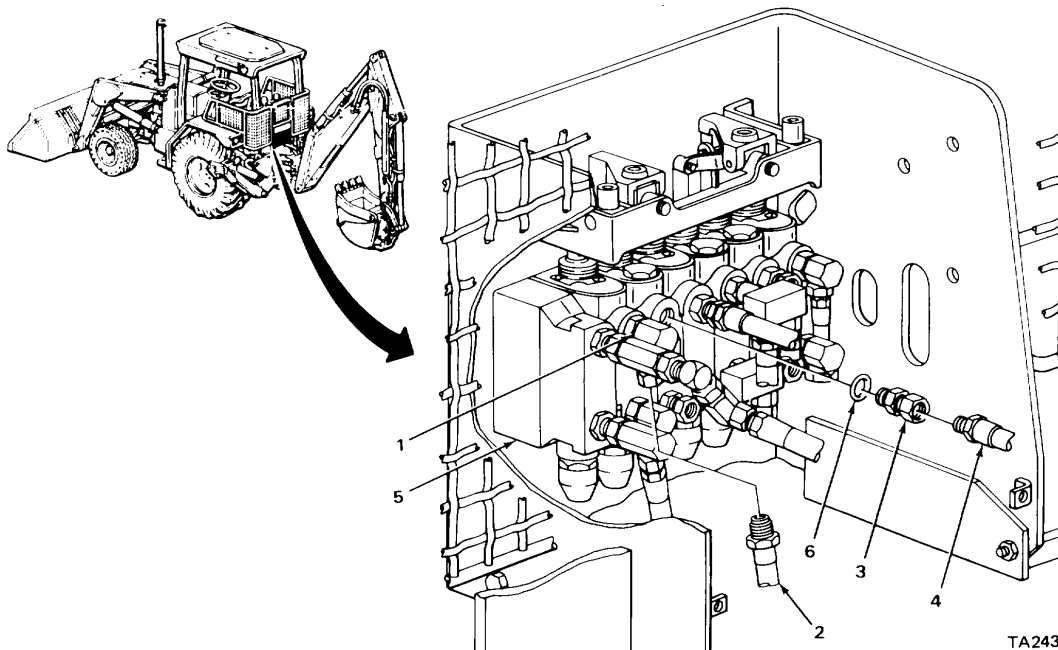

TA243479

BACKHOE CONTROL VALVE-TO-MANIFOLD BLOCK OIL LINES - CONTINUED

LOCATION	ITEM	ACTION	REMARKS
REMOVAL - CONTINUED			
5.	Straight adapter (1)	Hose (2)	<ul style="list-style-type: none"> a. Place drain pan underneath. b. Using 7/8-inch and 1-inch open-end wrenches, unscrew and take out. c. Tag (page 2-137).
6.	Manifold block (3)	Straight adapter (1) with assembled packing (4)	<ul style="list-style-type: none"> a. Using 7/8-inch open-end wrench, unscrew and take out. b. Plug manifold block (3) (page 2-137). c. Get rid of drained fluid (page 2-137).
7.	Straight adapter (1)	Packing (4)	<ul style="list-style-type: none"> a. Using pocket knife, take off. b. Get rid of.

CLEANING

NOTE

For more information on how to clean parts, go to **General Maintenance Instructions (page 2-137)**.

8.	Hose (2)	<ul style="list-style-type: none"> a. Using clean rags dampened in solution of detergent and water, wipe clean. b. Rinse with clean water. c. Using clean, dry rags, wipe dry.
----	----------	---

WARNING

Drycleaning solvent P-D-680 is toxic and flammable. Wear protective goggles and gloves and use only in a well ventilated area. Avoid contact with skin, eyes, and clothes and don't breathe vapors. Do not use near open flame or excessive heat. The flashpoint is 1000F to 1380F (380 to 590C). If you become dizzy while using cleaning solvent, get fresh air immediately and get medical aid. If contact with eyes is made, wash your eyes with water and get medical aid immediately.

9.	All metal parts	<ul style="list-style-type: none"> a. Clean in drycleaning solvent. b. Using clean dry rags, wipe dry.
----	-----------------	--

INSPECTION/REPLACEMENT

NOTE

For more information on how to inspect parts, go to **General Maintenance Instructions (page 2-137)**.

Replace defective parts as needed.

BACKHOE CONTROL VALVE-TO-MANIFOLD BLOCK OIL LINES - CONTINUED

LOCATION	ITEM	ACTION	REMARKS
10.	Hoses (2)		Look for cracks, breaks, cuts, and tears.
11.	All metal parts		Look for cracks and breaks.
12.	All threaded parts		Look for damaged threads.

INSTALLATION

- | | | |
|--------------------------|---|---|
| 13. Straight adapter (1) | New packing (4) | Place in position. |
| 14. Manifold block (3) | Straight adapter (1)
with assembled
packing (4) | a. Unplug manifold block (3).
b. Screw in and tighten using 7/8-inch
open-end wrench. |
| 15. Straight adapter (1) | Hose (2) | a. Take off tag.
b. Screw in and tighten using 7/8-inch
and 1-inch open-end wrenches. |

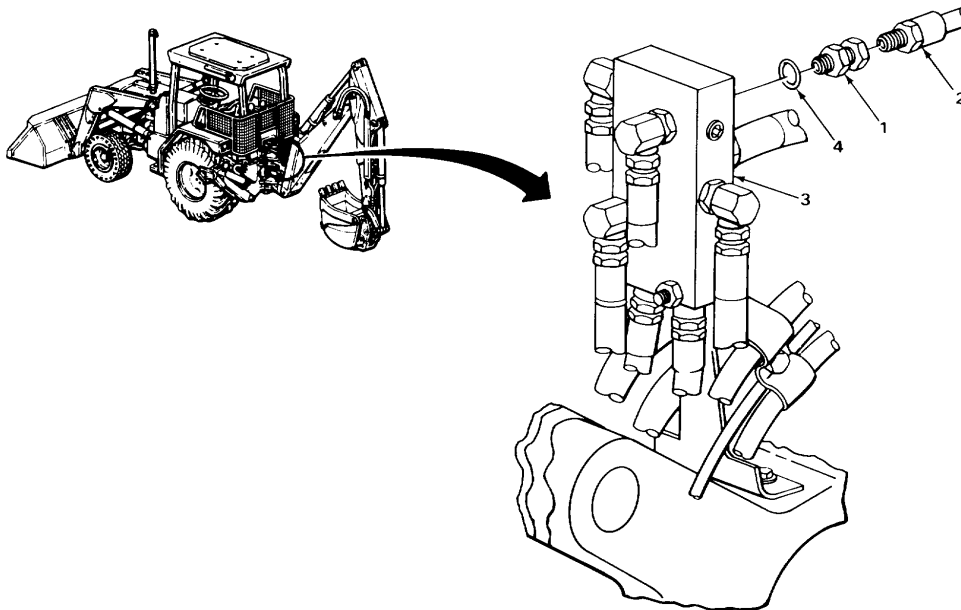

TA243480

BACKHOE CONTROL VALVE-TO-MANIFOLD BLOCK OIL LINES - CONTINUED

LOCATION	ITEM	ACTION	REMARKS
INSTALLATION - CONTINUED			
16.	Union adapter (1)	New packing (2)	Place in position.
17.	Valve (3)	Union adapter (1) with assembled packing (2)	a. Unplug valve (3). b. Screw in and tighten using 1-inch, 112-inch drive deep socket, 10-inch extension, and ratchet handle.
18.	Union adapter (1)	Hose (4)	a. Take off tag. b. Screw in and tighten using 7/8-inch and 1-inch open-end wrenches.
NOTE			
Perform step 19 if lower backhoe crowd valve-to-manifold block oil line was maintained. Skip step 19 when maintaining other five lines.			
19.	Union adapter (5)	Hose (6)	a. Unplug adapter (5). b. Take off tag. c. Uncap. d. Screw in and tighten using 11/16-inch and 718inch open-end wrenches.
20.	Two handle	Two control mounts (7)	Screw in to positions noted during removal. levers (8)
21.	Two handle mounts (7) and two control levers (8)	Two nuts (9)	Using 3/4-inch open-end wrench, tighten until seated against handle mounts (7).
22.	Two handle mounts (10)	Two four-way levers (11)	Screw in to positions noted during removal.
23.	Two handle mounts (10) and two four- way levers (11)	Two nuts (12)	Using 15/16-inch open-end wrench, tighten until seated against handle mounts (10).
24.	Loader backhoe	Transmission	Check fluid level and add proper amount and grade (TM 5-2420-222-10).
25.		Engine	Start and run at high idle (TM 5-2420-222-10).

BACKHOE CONTROL VALVE-TO-MANIFOLD BLOCK OIL LINES - CONTINUED

LOCATION	ITEM	ACTION	REMARKS
26.	Backhoe control valve-to-manifold block oil lines	a. Operate backhoe controls (TM 5-2420-222-10) and check for leaks. b. If leaking at any connection, tighten using 11/16-inch, 7/8-inch and 1-inch open-end wrenches. c. If leaking does not stop, shut down engine (TM 5-2420-222-10) and replace leaking connection packing, fitting, or hose as outlined in this task. d. If found leaking, repeat steps 24 thru 26.	
27.	Engine	If still running, shut down (TM 5-2420-222-10).	
28. Two handle mounts (10) and two four-way levers (11)	Two nuts (12)	Using 15/16-inch open-end wrench, loosen.	
29. Two handle mounts (10)	Two four-way levers (11)	Noting relative positions, unscrew and take out.	

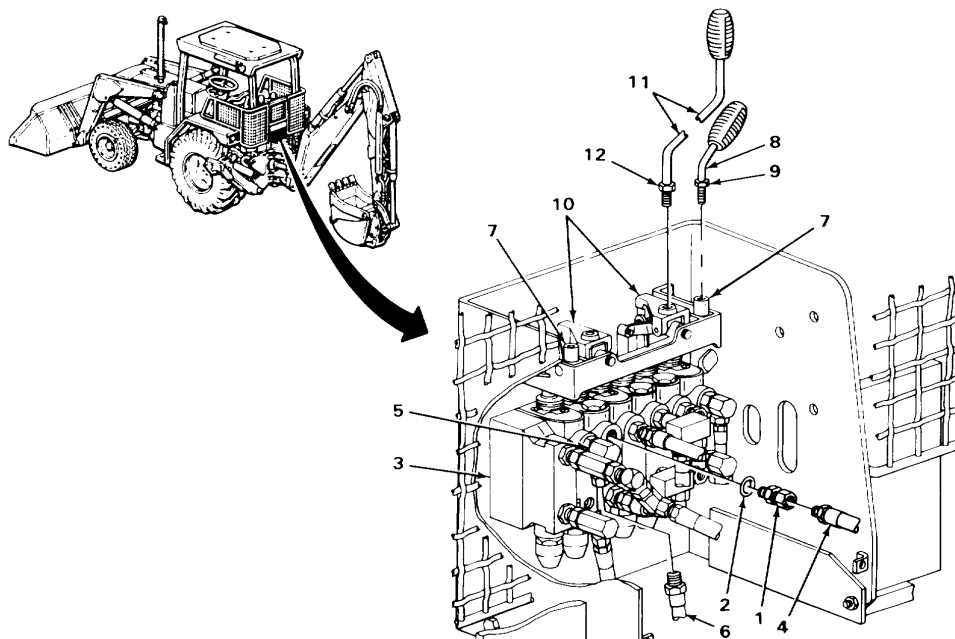

BACKHOE CONTROL VALVE-TO-MANIFOLD BLOCK OIL LINES - CONTINUED

LOCATION	ITEM	ACTION	REMARKS
INSTALLATION - CONTINUED			
30. Two handle mounts (1) and two control levers (2)	Two nuts (3)	Using 3/4-inch open-end wrench, loosen.	
31. Two handle mounts (1)	Two control levers (2)	Noting relative positions, unscrew and take out.	

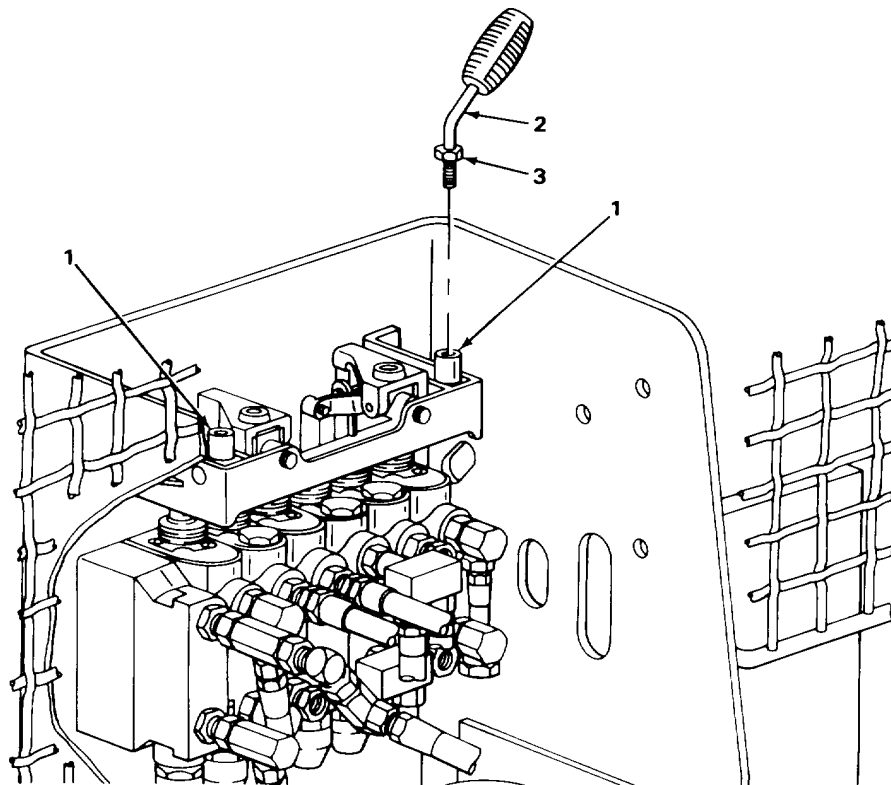

NOTE

FOLLOW-ON MAINTENANCE: Install backhoe valve box cover (page 2-1157).

TASK ENDS HERE

TA243482

MANIFOLD BLOCK-TO-HEAD END BOOM CYLINDER OIL LINE

This task covers:

- a. Removal (page 2-1565)
 - b. Cleaning (page 2-1567)
 - c. Inspection/Replacement (page 2-1568)
 - d. Installation (page 2-1568)
-

INITIAL SETUP

Tools

- Knife, pocket
- Pan, drain
- Wrench, open-end, 7/8-inch
- Wrench, open-end, 1-inch
- Wrench, open-end, 11/14-inch

Materials/Parts

- Detergent, GP (item 7, Appendix C)
- Packing, union adapter
- Packing, union adapter

Materials/Parts - Continued

- Rags, wiping (item 21, Appendix C)
- Solvent, drycleaning (item 28, Appendix C)
- Tags, marking (item 30, Appendix C)

Personnel Required

One

LOCATION	ITEM	ACTION	REMARKS
----------	------	--------	---------

REMOVAL

- | | | | |
|----|----------------|-------------------------------|--|
| 1. | Loader backhoe | Boom, dipperstick, and bucket | <ul style="list-style-type: none"> a. Extend as far as possible (TM 5-2420-222-10). b. Lower to ground so that boom and dipperstick are horizontal (TM 5-2420-222-10). |
| 2. | | Hydraulic system | Release pressure (page 2-1191). |

MANIFOLD BLOCK-TO-HEAD END BOOM CYLINDER OIL LINE - CONTINUED

LOCATION	ITEM	ACTION	REMARKS
REMOVAL - CONTINUED			
<u>WARNING</u>			
<p>Do not attempt to disconnect hydraulic lines and fittings while engine is running or before hydraulic system pressure has been released. When engine is running, hydraulic system is under pressure. Hydraulic system pressure should be 0 psi (0 kPa) before lines are disconnected. A line or fitting disconnected under pressure will blow off with a lot of force and could cause serious injury to personnel.</p> <p>Be careful when draining hot fluids. Wear gloves to protect your hands from hot parts and fluids or severe burns could result.</p>			
3.	Two union adapters (1 and 2)	Two hoses (3 and 4)	<ul style="list-style-type: none"> a. Place drain pan underneath. b. Using 7/8-inch and 1-inch open-end wrenches, unscrew and take out. c. Tag (page 2-137). d. Cap hose (4) and adapter (2) (page 2-137).
4.	Union adapter (1) and manifold block (5)	Nut (6)	Using 7/8-inch and 1-inch open-end wrenches, loosen.
5.	Manifold block (5)	Union adapter (1) with assembled parts	<ul style="list-style-type: none"> a. Note relative position for proper placement during installation. b. Using 1-inch open-end wrench, unscrew and take out. c. Plug manifold block (5) (page 2-137).
6.	Union adapter (1)	Packing (7)	<ul style="list-style-type: none"> a. Using pocket knife, take off. b. Get rid of.
7.	Union adapter (8)	Hose (3)	<ul style="list-style-type: none"> a. Place drain pan underneath. b. Using 7/8-inch and 1-inch open-end wrenches, unscrew and take out. c. Tag (page 2-137).
8.	Boom cylinder(9)	Union adapter (8) with assembled packing (10)	<ul style="list-style-type: none"> a. Using 1 1/4-inch open-end wrench, unscrew and take out. b. Plug cylinder (9) (page 2-137). unscrew and take out. c. Get rid of drained fluid (page 2-137).
9.	Union adapter (8)	Packing (10)	<ul style="list-style-type: none"> a. Using pocket knife, take off. b. Get rid of.

MANIFOLD BLOCK-TO-HEAD END BOOM CYLINDER OIL LINE - CONTINUED

LOCATION	ITEM	ACTION	REMARKS
----------	------	--------	---------

CLEANING

NOTE

For more information on how to clean parts, go to General Maintenance Instructions (page 2-137).

WARNING

Drycleaning solvent P-D-680 is toxic and flammable. Wear protective goggles and gloves and use only in a well ventilated area. Avoid contact with skin, eyes, and clothes and don't breathe vapors. Do not use near open flame or excessive heat. The flashpoint is 1000F to 1380F (380 to 590C). If you become dizzy while using cleaning solvent, get fresh air immediately and get medical aid. If contact with eyes is made, wash your eyes with water and get medical aid immediately.

- | | | |
|-----|-----------------|---|
| 10. | All metal parts | <ul style="list-style-type: none"> a. Clean in drycleaning solvent. b. Using clean, dry rags, wipe dry. |
|-----|-----------------|---|

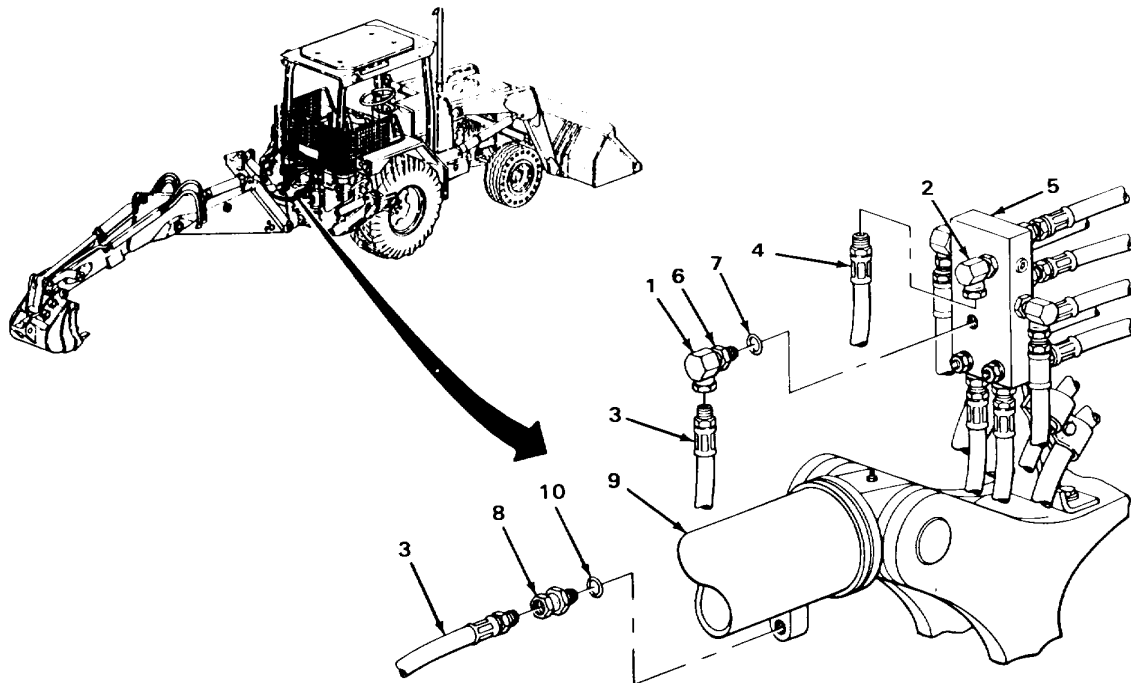

TA243483

MANIFOLD BLOCK-TO-HEAD END BOOM CYLINDER OIL LINE - CONTINUED

LOCATION	ITEM	ACTION	REMARKS
CLEANING - CONTINUED			
11.	Hose (1)	a. Using clean rags dampened in solution of detergent and water, wipe clean. b. Rinse with clean water. c. Using clean, dry rags, wipe dry.	
INSPECTION/REPLACEMENT			
NOTE			
For more information on how to inspect parts, go to General Maintenance Instructions (page 2-137) .			
Replace defective parts as needed.			
12.	Hose (1)		Look for cracks, breaks, cuts, and tears.
13.	All metal parts		Look for cracks and breaks.
14.	All threaded parts		Look for damaged threads.
INSTALLATION			
15. Union adapter (2)	New packing (3)		Place in position.
16. Boom cylinder (4)	Union adapter (2) with assembled packing (3)	a. Unplug cylinder (4). b. Screw on and tighten using 1 1/4 inch open-end wrench.	
17. Union adapter (2)	Hose (1)	a. Take off tag. b. Screw in and tighten using 7/8-inch and 1-inch open-end wrenches.	
18. Union adapter (5)	Nut (6)		Screw on all the way.
19.	New packing (7)		Place in position.
20. Manifold block (8)	Union adapter (5) with assembled parts	a. Unplug manifold block (8). b. Screw in and tighten to same relative position noted during removal using 16-inch open-end wrench.	
21. Union adapter (5) and manifold block (8)	Nut (6)		Using 7/8-inch and 1-inch open-end wrenches, tighten until seated against manifold block (8).

MANIFOLD BLOCK-TO-HEAD END BOOM CYLINDER OIL LINE - CONTINUED

LOCATION	ITEM	ACTION	REMARKS
22. Two union adapters (5 and 9)	Two hoses (1 and 10)	a. Uncap hose (9) and adapter (10). b. Take off tags. c. Screw in and tighten using 7/8-inch and 1-inch open-end wrenches.	
23. Loader backhoe	Transmission		Check fluid level and add proper amount and grade (TM 5-2420-222-10).
24.	Engine		Start and run at high idle (TM 5-2420-222-10).
25.	Manifold block-to-head end boom cylinder oil line		a. Operate backhoe boom (TM 5-2420-222-10) and check for leaks. b. If leaking at any connection, tighten using 7/8-inch, 1-inch, and 1 11/4-inch open-end wrenches. c. If leaking does not stop, shut down engine (TM 5-2420-222-10) and replace defective packing, fitting, or hose as outlined in this task. d. If found leaking, repeat steps 23 thru 25.
26.	Engine		If still running, shut down (TM 5-2420-222-10).

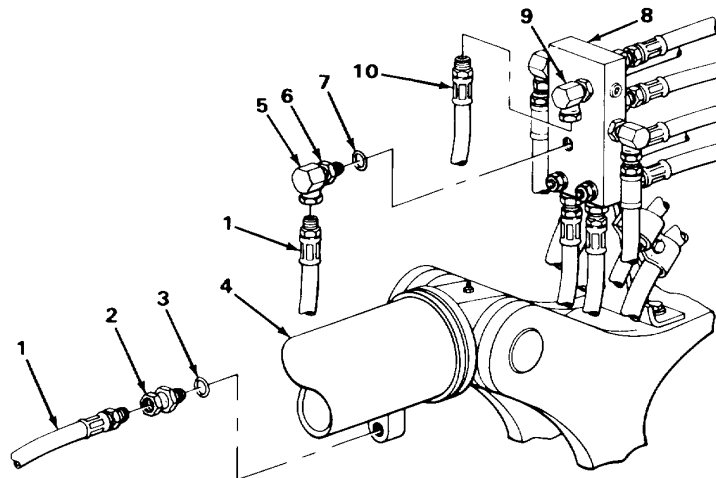

TASK ENDS HERE

MANIFOLD BLOCK-TO-CROWD CYLINDER OIL LINES (SERIAL NUMBERS 235786 THRU 235999 ONLY)

This task covers:

- a. Removal (page 2-1571)
 - b. Cleaning (page 2-1573)
 - c. Inspection/Replacement (page 2-1574)
 - d. Installation (page 2-1574)
-

INITIAL SETUP

Tools

- Handle, ratchet, 3/8-inch drive
- Knife, pocket
- Pan, drain
- Pliers, diagonal-cutting
- Pliers, slip-joint
- Socket, 3/8-inch drive, 9/16-inch
- Wrench, box, 9/16-inch
- Wrench, open-end, 7/8-inch
- Wrench, open-end, 1-inch
(two required)

Materials/Parts

- Band, hose
- Detergent, GP (item 7, Appendix C)
- Nut, special, clamp screw (two required)
- Packing, union adapter (two required)
- Packing, union adapter (two required)
- Rags, wiping (item 21, Appendix C)
- Solvent, drycleaning (item 28, Appendix C)
- Tags, marking (item 30, Appendix C)

Personnel Required

One

LOCATION	ITEM	ACTION	REMARKS
----------	------	--------	---------

NOTE

Original equipment crowd cylinders on loader backhoes with Serial Numbers 235786 thru 235999 are different from cylinders supplied on loader backhoes with Serial Numbers 319995 thru 342573. Old style cylinder assemblies are not available for replacement and must be replaced with new style when entire assembly is replaced. All necessary fittings, tubes, and hardware items required for installation are included with new style crowd cylinder only when old style crowd cylinder part number is ordered. If your loader backhoe has new style crowd cylinder installed, go to Manifold Block-to-Crowd Cylinder Oil Lines (Serial Numbers 319995 thru 342573 only) (page 2-1578).

Both manifold block-to-crowd cylinder oil lines are maintained in same way. Manifold block-to-rod end crowd cylinder oil line is shown. Repeat procedures as needed for manifold block-to-head end crowd cylinder oil line.

MANIFOLD BLOCK-TO-CROWD CYLINDER OIL LINES (SERIAL NUMBERS 235786 THRU 235999 ONLY) - CONTINUED

LOCATION	ITEM	ACTION REMARKS
REMOVAL		
1. Loader backhoe	Boom, dipperstick, and bucket	a. Extend as far as possible (TM 5-2420-222-10). b. Lower to ground so that boom and dipperstick are horizontal (TM 5-2420-222-10).
2.	Hydraulic system	Release pressure (page 2-1191).
3. Boom (1) and two clamps (2)	Two screws (3) and special nuts (4)	a. Using 9/16-inch, 3/8-inch drive socket, ratchet handle, and 9/16-inch box wrench, unscrew and take apart. b. Get rid of special nuts (4).
4. Boom (1) and hose (5)	Two clamps (2)	Take off.
5. Nine hoses (5 thru 13)	Band (14)	a. Using diagonal-cutting pliers, cut off. b. Get rid of.

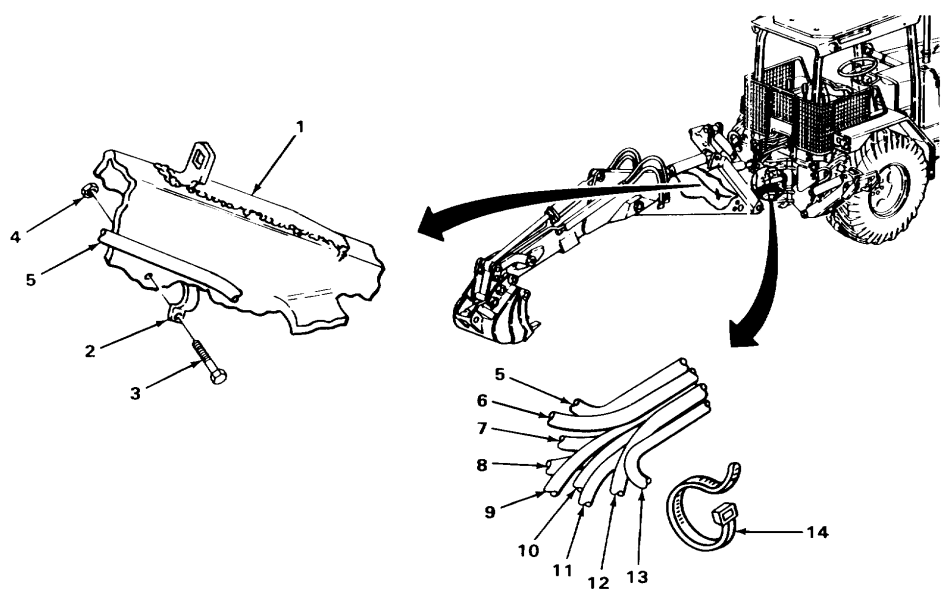

TA243485

MANIFOLD BLOCK-TO-CROWD CYLINDER OIL LINES (SERIAL NUMBERS 235786 THRU 235999 ONLY) - CONTINUED

LOCATION	ITEM	ACTION REMARKS
REMOVAL - CONTINUED		
WARNING		
<p>Do not attempt to disconnect hydraulic lines and fittings while engine is running or before hydraulic system pressure has been released. When engine is running, hydraulic system is under pressure. Hydraulic system pressure should be 0 psi (0 kPa) before lines are disconnected. A line or fitting disconnected under pressure will blow off with a lot of force and could cause serious injury to personnel.</p>		
<p>Be careful when draining hot fluids. Wear gloves to protect your hands from hot parts and fluids or severe burns could result.</p>		
6. Union adapter (1)	Hose (2)	a. Place drain pan underneath. b. Using two 1-inch open-end wrenches, unscrew and take out. c. Tag (page 2-137).
7. Crowd cylinder (3)	Union adapter (1) with assembled packing (4)	a. Using 1-inch open-end wrench, unscrew and take out. b. Plug cylinder (3) (page 2-137).
8. Union adapter (1)	Packing (4)	a. Using pocket knife, take off. b. Get rid of.
9. Union adapter (5)	Hose (2)	a. Place drain pan underneath. b. Using two 1-inch open-end wrenches, unscrew and take out. c. Tag (page 2-137).
10.	Nut (6)	Using 7/8-inch and 1-inch open-end wrenches, loosen.
11. Manifold block (7)	Union adapter (5) with assembled parts	a. Note relative position for proper placement during installation. b. Using 1-inch open-end wrench, unscrew and take out. c. Plug manifold block (7) (page 2-137). d. Get rid of drained fluid (page 2-137).
12. Union adapter(5)	Packing (8)	a. Using pocket knife, take off. b. Get rid of.

MANIFOLD BLOCK-TO-CROWD CYLINDER OIL LINES (SERIAL NUMBERS 235786 THRU 235999 ONLY) - CONTINUED

LOCATION	ITEM	ACTION	REMARKS
13. Boom (9)	Hose (2)	a. Note routing for proper placement during installation. b. Take out.	

CLEANING

NOTE

For more information on how to clean parts, go to **General Maintenance Instructions (page 2-137)**.

14.	Hose (2)	a. Using clean rags dampened in solution of detergent and water, wipe clean. b. Rinse with clean water. c. Using clean, dry rags, wipe dry.
-----	----------	---

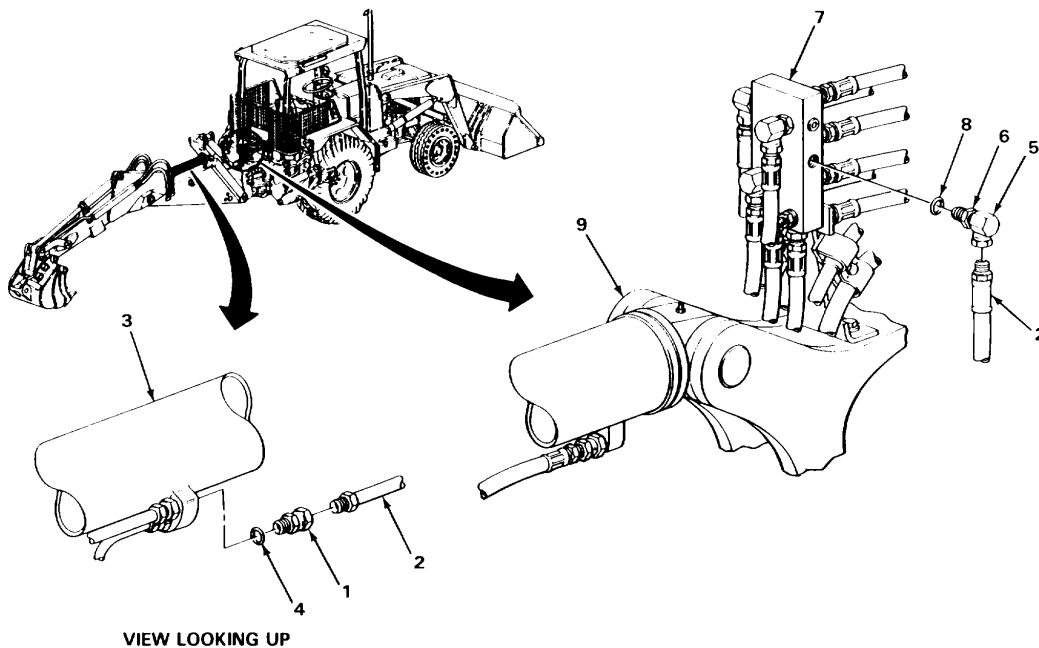

TA243486

**MANIFOLD BLOCK-TO-CROWD CYLINDER OIL LINES (SERIAL NUMBERS 235786 THRU 235999 ONLY)-
CONTINUED**

LOCATION	ITEM	ACTION	REMARKS
----------	------	--------	---------

CLEANING - CONTINUED

WARNING

Drycleaning solvent P-D-680 is toxic and flammable. Wear protective goggles and gloves and use only in a well ventilated area. Avoid contact with skin, eyes, and clothes and don't breathe vapors. Do not use near open flame or excessive heat. The flashpoint is 100°F to 138°F (38° to 59°C). If you become dizzy while using cleaning solvent, get fresh air immediately and get medical aid. If contact with eyes is made, wash your eyes with water and get medical aid immediately.

- | | | | |
|-----|-----------------|----------------------------------|-------------------------------------|
| 15. | All metal parts | a. Clean in drycleaning solvent. | b. Using clean, dry rags, wipe dry. |
|-----|-----------------|----------------------------------|-------------------------------------|

INSPECTION/REPLACEMENT

NOTE

For more information on how to inspect parts, go to General Maintenance Instructions (page 2-137).

Replace defective parts as needed.

- | | | | |
|-----|--------------------|--|--|
| 16. | Hose (1) | Look for cracks, breaks, cuts, and tears. | |
| 17. | All metal parts | Look for cracks, breaks, and abnormal bends. | |
| 18. | All threaded parts | Look for damaged threads. | |

INSTALLATION

- | | | | |
|------------------------|---|---|--|
| 19. | Boom (2) Hose (1) | Using same routing noted during removal, place in position. | |
| 20. | Union adapter (3) | Nut (4) Screw on all the way. | |
| 21. | New packing (5) | Place in position. | |
| 22. Manifold block (6) | Union adapter (3)
with assembled parts | a. Unplug manifold block (6). | b. Screw in and tighten to same relative position noted during removal using 1-inch open-end wrench. |

MANIFOLD BLOCK-TO-CROWD CYLINDER OIL LINES (SERIAL NUMBERS 235786 THRU 235999 ONLY) - CONTINUED

LOCATION	ITEM	ACTION	REMARKS
23. Union adapter (3)	Hose (1)	a. Take off tag. b. Screw in and tighten using two 1-inch open-end wrenches.	
24. Union adapter (7)	New packing (8)		Place in position.
25. Crowd cylinder (9)	Union adapter (7) with assembled packing (8)	a. Unplug cylinder (9). b. Screw in and tighten using 1-inch open-end wrench.	
26. Union adapter (7)	Hose (1)	a. Take off tag. b. Screw in and tighten using two 1-inch open-end wrenches.	

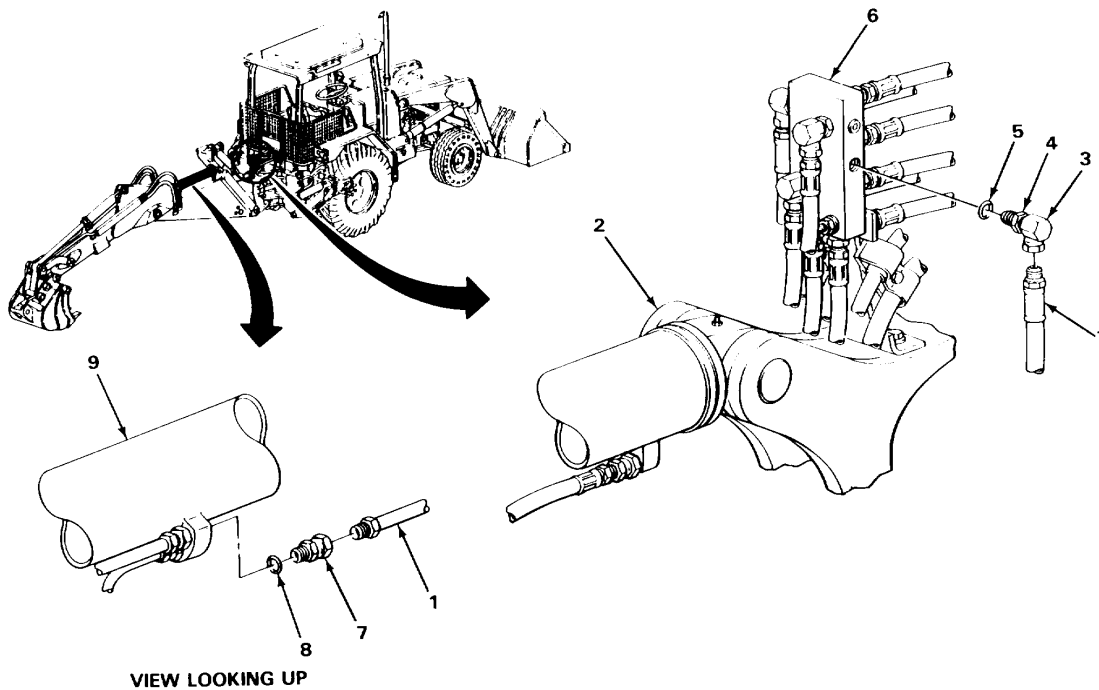

TA243487

MANIFOLD BLOCK-TO-CROWD CYLINDER OIL LINES (SERIAL NUMBERS 235786 THRU 235999 ONLY) - CONTINUED

LOCATION	ITEM	ACTION REMARKS
INSTALLATION - CONTINUED		
27. Boom (1) and hose (2)	Two clamps (3)	Place in position.
28. Boom (1) and two clamps (3)	Two screws (4) and new special nuts (5)	Screw together and tighten using 9/16-inch, 3/8-inch drive socket, ratchet handle and 9/16-inch box wrench.
29. Nine hoses (2 and 6 thru 13)	New band (14)	<ul style="list-style-type: none"> a. Place in position. b. Using slip-joint pliers, tighten until snug.
30. Loader backhoe	Transmission	Check fluid level and add proper amount and grade (TM 5-2420-222-10).
31.	Engine	Start and run at high idle (TM 5-2420-222-10).
32.	Manifold block-to-crowd cylinder oil lines	<ul style="list-style-type: none"> a. Operate crowd controls (TM 5-2420-222-10) and check for leaks. b. If leaking at any connection, tighten using 7/8-inch and two 1-inch open-end wrenches. c. If leaking does not stop, shut down engine (TM 5-2420-222-10) and replace leaking connection packing, fitting, or hose as outlined in this task. d. If found leaking, repeat steps 30 thru 32.
33.	Engine	If still running, shut down (TM 5-2420-222-10).

MANIFOLD BLOCK-TO-CROWD CYLINDER OIL LINES (SERIAL NUMBERS 235786 THRU 235999 ONLY) - CONTINUED

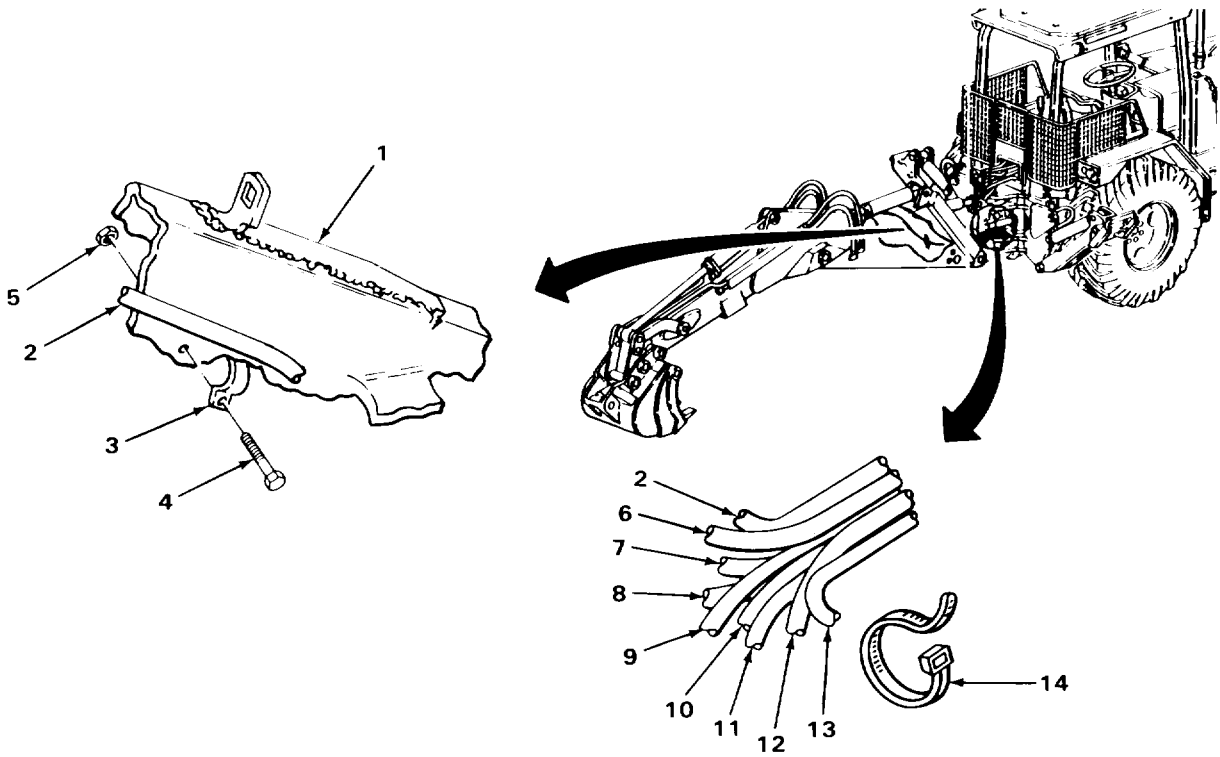

TASK ENDS HERE

MANIFOLD BLOCK-TO-CROWD CYLINDER OIL LINES (SERIAL NUMBERS 319995 THRU 342573 ONLY)

This task covers:

- | | |
|---------------------------|---|
| a. Removal (page 2-1579) | c. Inspection/Replacement (page 2-1585) |
| b. Cleaning (page 2-1584) | d. Installation (page 2-1585) |

INITIAL SETUP:

Tools

- Blocks, wood
- Drift pin, brass-tipped, 3/4-inch
- Hammer, ball-peen, 2-pound head
- Handle, ratchet, 1/2-inch drive
- Knife, pocket
- Lifting equipment, 200-pound capacity
- Pan, drain
- Pliers, diagonal-cutting
- Pliers, slip-joint
- Screwdriver, flat-tip, 1/4-inch
- Socket, 1/2-inch drive, 9/16-inch
- Socket, 1/2-inch drive, 3/4-inch
- Wrench, box, 9/16-inch
- Wrench, box, 3/4-inch
- Wrench, box, 1-inch
- Wrench, open-end, 7/8-inch
- Wrench, open-end, 1-inch (two required)
- Wrench, open-end, 1 1/4-inch

Materials/Parts

- Band, hoses
- Detergent, GP (item 7, Appendix C)
- Locknut, cylinder pin screw
- Nut, special, clamp screw (four required)
- Packing, adapter
- Packing, connector
- Packing, union adapter (two required)
- Rags, wiping (item 21, Appendix C)
- Solvent, drycleaning (item 28, Appendix C)
- Tags, marking (item 30, Appendix C)

Personnel Required

- One

LOCATION	ITEM	ACTION	REMARKS
----------	------	--------	---------

NOTE

Original equipment crowd cylinders on loader backhoes with Serial Numbers 235786 thru 235999 are different from cylinders supplied on loader backhoes with Serial Numbers 319995 thru 342573. Old style cylinder assemblies are not available for replacement and must be replaced with new style when entire assembly is replaced. All necessary fittings, tubes, and hardware items required for installation are included with the new style crowd cylinder only when the old style crowd cylinder part number is ordered.

Both manifold block-to-crowd cylinder oil lines are maintained the same way except as noted. Manifold block-to-head end crowd cylinder rod end is shown. Repeat procedures as needed for manifold block-to-rod end crowd cylinder oil line.

MANIFOLD BLOCK-TO-CROWD CYLINDER OIL LINES (SERIAL NUMBERS 31995 THRU 342573 ONLY) - CONTINUED

LOCATION	ITEM	ACTION	REMARKS
REMOVAL			
1. Loader backhoe	Boom, dipperstick, and bucket	a. Extend as far as possible (TM 5-2420-222-10). b. Lower to ground so that boom and dipperstick are horizontal (TM 5-2420-222-10).	
2.	Hydraulic system	Release pressure (page 2-1191).	
3. Spacer (1), hose (2), tube (3), and crowd cylinder (4)	Clamp (5)	Using 1/4-inch flat-tip screwdriver, unscrew and take off.	
4. Hose (2), tube (3), and crowd cylinder (4)	Spacer (1)	a. Note relative position for proper placement during installation. b. Take off.	

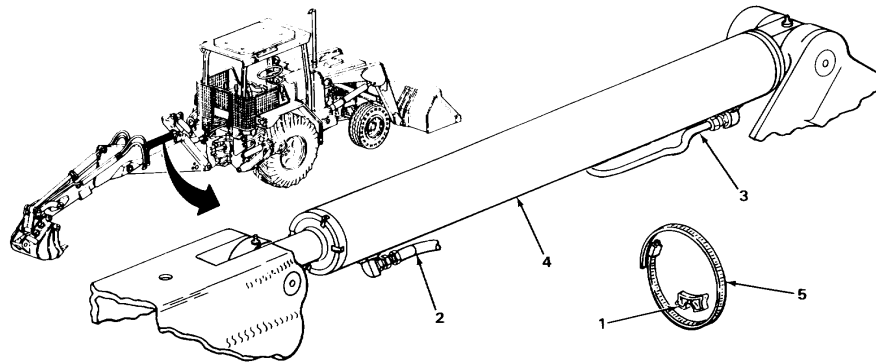

TA243489

MANIFOLD BLOCK-TO-CROWD CYLINDER OIL LINES (SERIAL NUMBERS 31995 THRU 342573 ONLY) - CONTINUED

LOCATION	ITEM	ACTION	REMARKS
REMOVAL - CONTINUED			
5. Boom (1) and two clamps (2)	Two screws (3) and special nuts (4)	a. Using 9/16-inch, 1/2-inch drive socket, ratchet handle, and 9/16-inch box wrench, unscrew and take apart. b. Get rid of special nuts (4).	
6. Boom (1) and hose (5)	Two clamps (2)	Take off.	
7. Nine hoses (5 thru 13)	Band (14)	a. Using diagonal-cutting pliers, cut off. b. Get rid of.	

WARNING

Do not attempt to disconnect hydraulic lines and fittings while engine is running or before hydraulic system pressure has been released. When engine is running, hydraulic system is under pressure. Hydraulic system pressure should be 0 psi (0 kPa) before lines are disconnected. A line or fitting disconnected under pressure will blow off with a lot of force and could cause serious injury to personnel.

Be careful when draining hot fluids. Wear gloves to protect your hands from hot parts and fluids or severe burns could result.

NOTE

If manifold block-to-rod end crowd cylinder oil line is being removed, skip steps 8 thru 15.

8. Tube(15)	Hose (5)	a. Place drain pan underneath. b. Using two 1-inch open-end wrenches, unscrew and take out. c. Tag (page 2-137).	
9. Connector (16)	Tube (15)	a. Note relative position for proper placement during installation. b. Slide 1-inch box wrench on. c. Using 1-inch box wrench, unscrew and take off.	

NOTE

Crowd cylinder must be disconnected to remove connector from cylinder. Do not remove connector unless inspection shows need for replacement. If connector is not being removed, skip steps 10 thru 15.

MANIFOLD BLOCK-TO-CROWD CYLINDER OIL LINES (SERIAL NUMBERS 31995 THRU 342573 ONLY) - CONTINUED

LOCATION	ITEM	ACTION	REMARKS
----------	------	--------	---------

10. Dipperstick (17) and pin (18)	Screw (19) and locknut (20)	a. Using 3/4-inch, 1/2-inch drive socket, ratchet handle, and 3/4-inch box wrench, unscrew and take apart. b. Get rid of locknut (20).	
-----------------------------------	-----------------------------	---	--

WARNING

Some parts are heavy. Be careful when handling them. Lifting equipment is needed when parts weigh over 50 pounds (23 kg) for a single person lift, over 100 pounds (45 kg) for a two person lift, and over 150 pounds (68 kg) for a three or more person lift. Do not try to handle heavy parts without lifting equipment. Keep clear of heavy parts supported only by lifting equipment. Failure to observe this precaution could cause serious injury or death of personnel.

11. Boom (1) and dipperstick (17)	Crowd cylinder (21)	Attach 200-pound capacity lifting equipment and support.	
-----------------------------------	---------------------	--	--

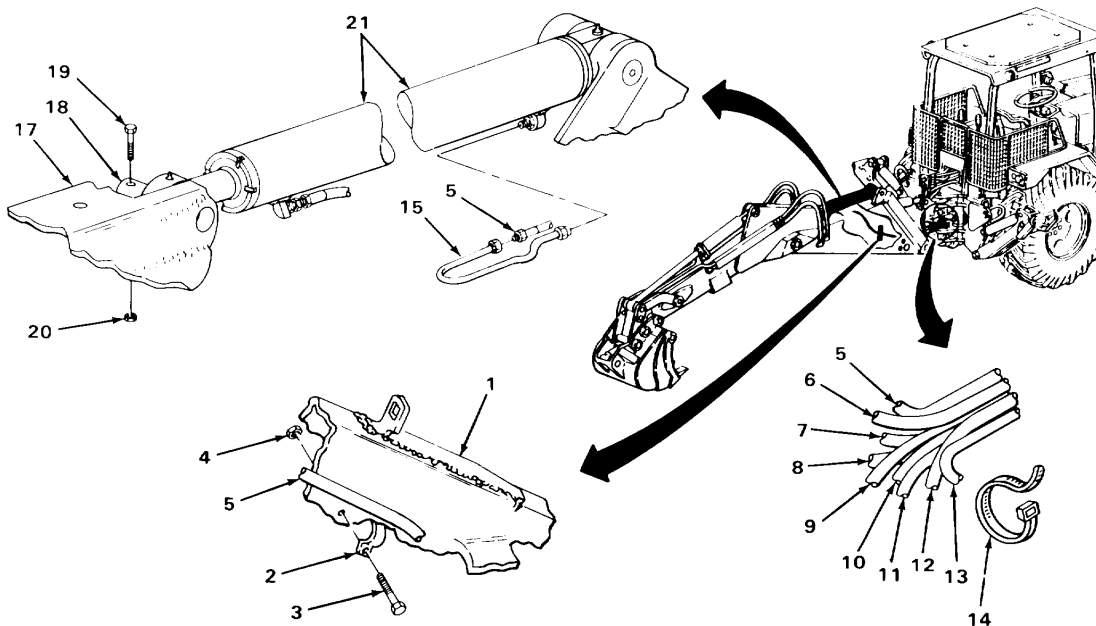

TA243490

MANIFOLD BLOCK-TO-CROWD CYLINDER OIL LINES (SERIAL NUMBERS 319995 THRU 342573 ONLY) - CONTINUED

LOCATION	ITEM	ACTION	REMARKS
REMOVAL - CONTINUED			
<u>WARNING</u>			
<p>Some parts are heavy. Be careful when handling them. Lifting equipment is needed when parts weigh over 50 pounds (23 kg) for a single person lift, over 100 pounds (45 kg) for a two person lift, and over 150 pounds (68 kg) for a three or more person lift. Do not try to handle heavy parts without lifting equipment. Keep clear of heavy parts supported only by lifting equipment. Failure to observe this precaution could cause serious injury or death of personnel.</p>			
12. Dipperstick (1) and crowd cylinder (2)	Pin (3)		Using 3/4-inch brass-tipped driftpin and and 2-pound head ball-peen hammer, drive out.
13. Dipperstick (1)	Crowd cylinder (2)	<ul style="list-style-type: none"> a. Using 200-pound capacity lifting equipment, raise. b. Place wood block in position. c. Using 200-pound capacity lifting equipment, lower onto wood blocks. 	
14. Crowd cylinder (2)	Connector (4) with assembled packing (5)	<ul style="list-style-type: none"> a. Using 1 1/4-inch open-end wrench, unscrew and take out. b. Plug cylinder (2) (page 2-137). 	
15. Connector (4)	Packing (5)	<ul style="list-style-type: none"> a. Using pocket knife, take off. b. Get rid of. 	

NOTE

If manifold block-to-head end crowd cylinder oil line is being removed, skip steps 16 thru 18.

WARNING

Do not attempt to disconnect hydraulic lines and fittings while engine is running or before hydraulic system pressure has been released. When engine is running, hydraulic system is under pressure. Hydraulic system pressure should be 0 psi (0 kPa) before lines are disconnected. A line or fitting disconnected under pressure will blow off with a lot of force and could cause serious injury to personnel.

Be careful when draining hot fluids. Wear gloves to protect your hands from hot parts and fluids or severe burns could result.

MANIFOLD BLOCK-TO-CROWD CYLINDER OIL LINES (SERIAL NUMBERS 31995 THRU 342573 ONLY) - CONTINUED

LOCATION	ITEM	ACTION	REMARKS
16. Adapter (6)	Hose (7)	a. Place drain pan underneath. b. Using two 1-inch open-end wrenches, unscrew and take out. c. Tag (page 2-137).	
17. Crowd cylinder (2)	Adapter (6) with assembled packing (8)	a. Using 1 1/4-inch open-end wrench, unscrew and take out. b. Plug cylinder (2) (page 2-137).	
18. Adapter (6)	Packing (8)	a. Using pocket knife, take off. b. Get rid of.	

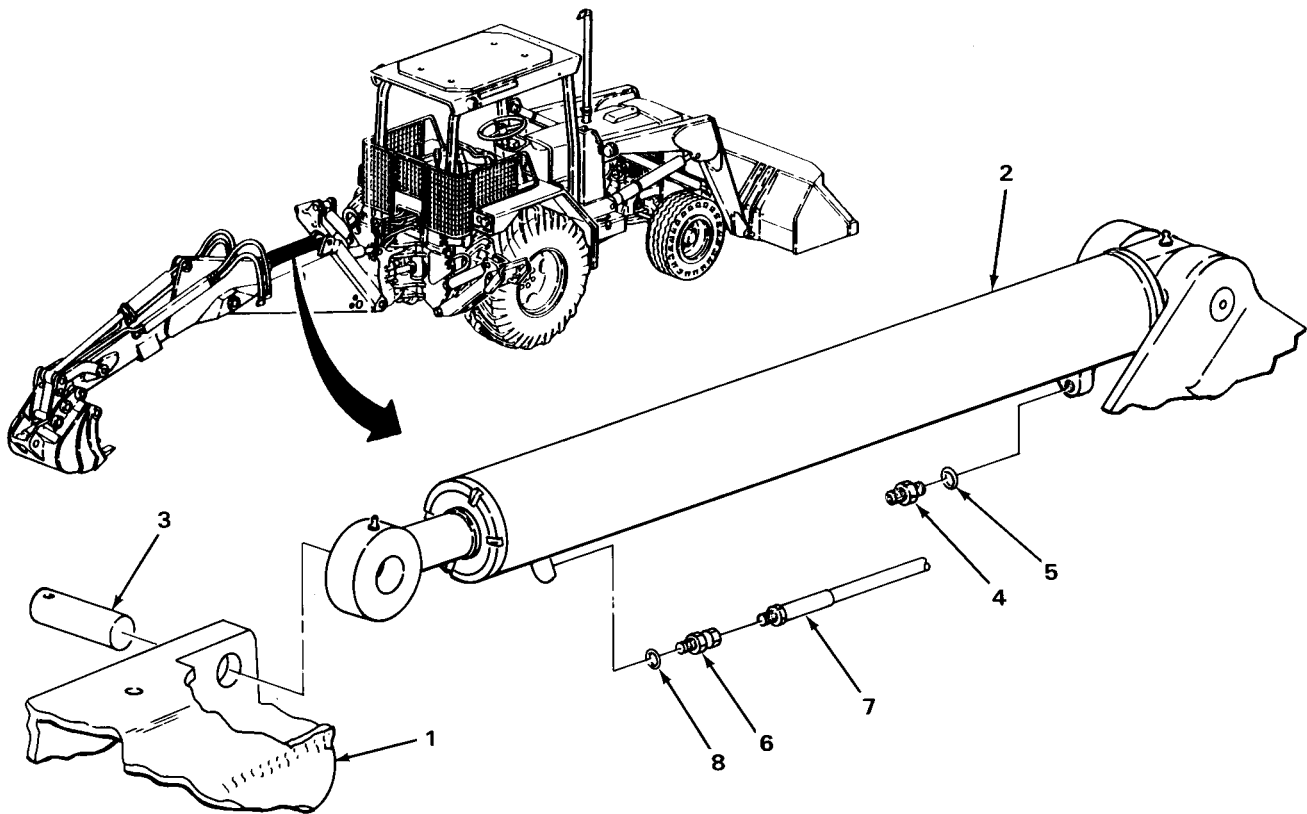

MANIFOLD BLOCK-TO-CROWD CYLINDER OIL LINES (SERIAL NUMBERS 319995 THRU 342573 ONLY) - CONTINUED

LOCATION	ITEM	ACTION REMARKS
REMOVAL - CONTINUED		
19. Union adapter (1)	Hose (2)	<ul style="list-style-type: none"> a. Place drain pan underneath. b. Using two 1-inch open-end wrenches, unscrew and take out. c. Tag (page 2-137).
20. Manifold block (3) and union adapter (1)	Nut (4)	Using 7/8-inch and 1-inch open-end wrenches, loosen.
21. Manifold block (3)	Union adapter (1) with assembled packing (5)	<ul style="list-style-type: none"> a. Note relative position for proper placement during installation. b. Using 1-inch open-end wrench, unscrew and take out. c. Plug manifold block (3) (page 2-137). d. Get rid of drained fluid (page 2-137).
22. Union adapter (1)	Packing (5)	<ul style="list-style-type: none"> a. Using pocket knife, take out. b. Get rid of.
23. Boom (6)	Hose (2)	<ul style="list-style-type: none"> a. Note routing for proper placement during installation. b. Pull out.

CLEANING**NOTE**

For more information on how to clean parts, go to General Maintenance Instructions (page 2-137).

24.	All plastic and rubber parts	<ul style="list-style-type: none"> a. Using clean rags dampened in solution of detergent and water, wipe clean. b. Rinse in clean water. c. Using clean, dry rags, wipe dry.
-----	------------------------------	---

WARNING

Drycleaning solvent P-D-680 is toxic and flammable. Wear protective goggles and gloves and use only in a well ventilated area. Avoid contact with skin, eyes, and clothes and don't breathe vapors. Do not use near open flame or excessive heat. The flashpoint is 100°F to 138°F (38° to 59°C). If you become dizzy while using cleaning solvent, get fresh air immediately and get medical aid. If contact with eyes is made, wash your eyes with water and get medical aid immediately.

**MANIFOLD BLOCK-TO-CROWD CYLINDER OIL LINES (SERIAL NUMBERS 31995 THRU 342573 ONLY)-
CONTINUED**

LOCATION	ITEM	ACTION	REMARKS
25.	All metal parts	a. Clean in drycleaning solvent. b. Using clean, dry rags, wipe dry.	

INSPECTION/REPLACEMENT

NOTE

For more information on how to inspect parts, go to **General Maintenance Instructions (page 2-137)**.

Replace defective parts as needed.

26 .	Hose (2)	Look for cracks, breaks, cuts, and tears.
27.	Spacer (7)	Look for cracks and breaks.
28.	All metal parts	Look for cracks, breaks, and abnormal bends.
29.	All threaded parts	Look for damaged threads.

INSTALLATION

30. Boom (6)	Hose (2)	Using same routing noted during removal, place in position.
--------------	----------	---

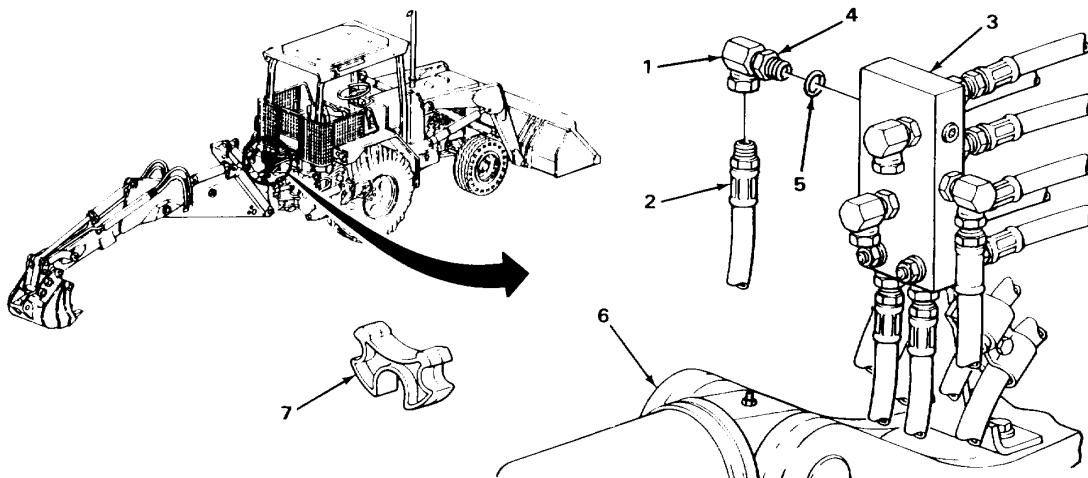

TA243492

MANIFOLD BLOCK-TO-CROWD CYLINDER OIL LINES (SERIAL NUMBERS 319995 THRU 342573 ONLY) - CONTINUED

LOCATION	ITEM	ACTION REMARKS
INSTALLATION - CONTINUED		
31. Union adapter (1)	Nut (2)	Screw on all the way.
32.	New packing (3)	Place in position.
33. Manifold block (4)	Union adapter (1) with assembled packing (3)	a. Unplug manifold block (4). b. Screw in and tighten to same relative position noted during removal using 1- inch open-end wrench.
34. Manifold block (4) and union adapter (1)	Nut (2)	Using 7/8-inch and 1-inch open-end wrenches, tighten until seated against manifold block (4).
35. Union adapter (1)	Hose (5)	a. Take off tag. b. Screw in and tighten using two 1-inch open-end wrenches.

NOTE

If manifold block-to-head end crowd cylinder oil line is being installed, skip steps 36 thru 38.

36. Adapter (6)	New packing (7)	Place in position.
37. Crowd cylinder (8)	Adapter (6) with assembled packing (7)	a. Unplug cylinder (8). b. Screw in and tighten using 1 1/4-inch open-end wrench.
38. Adapter (6)	Hose (9)	a. Take off tag. b. Screw in and tighten using two 1-inch open-end wrenches.

NOTE

If manifold block-to-rod end crowd cylinder oil line is being installed, skip steps 39 thru 46.

If connector was not removed, skip steps 39 thru 44.

39. Connector(10)	New packing (11)	Place in position.
-------------------	------------------	--------------------

MANIFOLD BLOCK-TO-CROWD CYLINDER OIL LINES (SERIAL NUMBERS 31995 THRU 34253 ONLY) - CONTINUED

LOCATION	ITEM	ACTION	REMARKS
----------	------	--------	---------

40. Crowd cylinder (8)

Connector (10) with assembled packing (11)

- a. Unplug cylinder (8).
- b. Screw in and tighten using 1 1/4-inch open-end wrench.

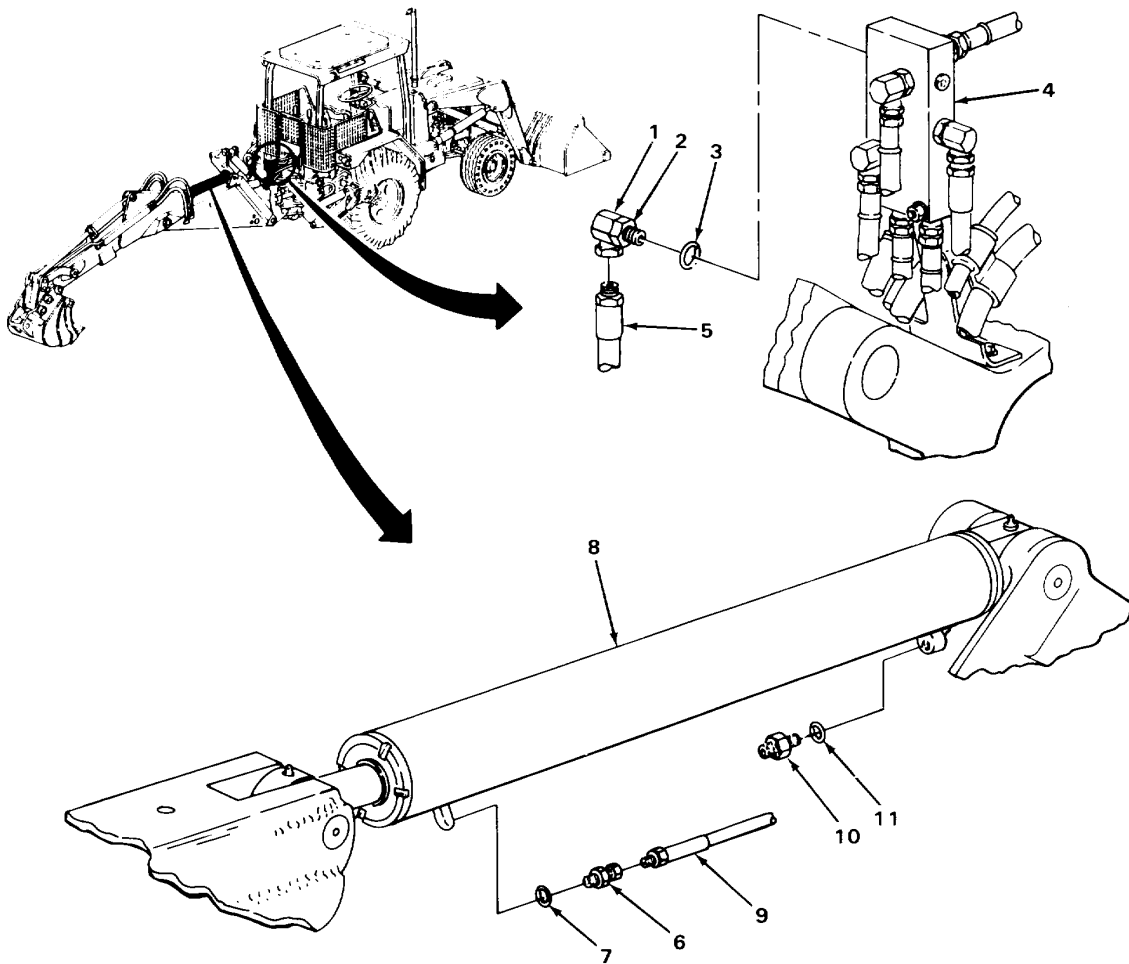

TA243493

MANIFOLD BLOCK-TO-CROWD CYLINDER OIL LINES (SERIAL NUMBERS 31995 THRU 342573 ONLY) - CONTINUED

LOCATION	ITEM	ACTION	REMARKS
INSTALLATION - CONTINUED			
<u>WARNING</u>			
<p>Some parts are heavy. Be careful when handling them. Lifting equipment is needed when parts weigh over 50 pounds (23 kg) for a single person lift, over 100 pounds (45 kg) for a two person lift, and over 150 pounds (68 kg) for a three or more person lift. Do not try to handle heavy parts without lifting equipment. Keep clear of heavy parts supported only by lifting equipment. Failure to observe this precaution could cause serious injury or death of personnel.</p>			
41. Dipperstick (1)	Crowd cylinder (2)	<ul style="list-style-type: none"> a. Using 200-pound capacity lifting equipment, lift off of wood blocks. b. Take out wood blocks. c. Using 200-pound capacity lifting equipment, lower into position. 	
42. Dipperstick (1) and crowd cylinder (2)	Pin (3)	Using 2-pound head ball-peen hammer,	tap in, alining holes.
43. Dipperstick (1) and pin (3)	Screw (4) and new locknut (5)	Screw together and tighten using 3/4-inch 1/2-inch drive socket, ratchet handle, and 3/4-inch box wrench.	
44. Dipperstick (1) and boom (6)	Crowd cylinder (2)	Disconnect 200-pound capacity lifting equipment.	
45. Connector (7)	Tube (8)	<ul style="list-style-type: none"> a. Slide 1-inch box wrench on. b. Screw on to same relative position noted during removal and tighten using 1-inch box wrench. 	
46. Tube (8)	Hose (9)	<ul style="list-style-type: none"> a. Take off tag. b. Screw in and tighten using two 1-inch open-end wrenches. 	
47. Nine hoses (9 thru 17)	New band (18)	<ul style="list-style-type: none"> a. Place in position. b. Using slip-joint pliers, tighten until snug. 	
48. Boom (6) and hose (9)	Two clamps (19)	Place in position.	
49. Boom (6) and two clamps (19)	Two screws (20) and special nuts (21)	Screw together and tighten using 9/16-inch, 1/2-inch drive socket, ratchet handle, and 9/16-inch box wrench.	

MANIFOLD BLOCK-TO-CROWD CYLINDER OIL LINES (SERIAL NUMBERS 31995 THRU 342573 ONLY) - CONTINUED

LOCATION	ITEM	ACTION	REMARKS
50. Hose (9), tube (8), and crowd cylinder (2)	Spacer (22)	Place in same relative position noted during removal.	
51. Spacer (22), hose (9), tube (8), and crowd cylinder (2)	Clamp (23)	Screw on and tighten using 1/4-inch flat-tip screwdriver.	
52. Loader backhoe	Transmission	Check fluid level and add proper amount and grade (TM 5-2420-222-10).	

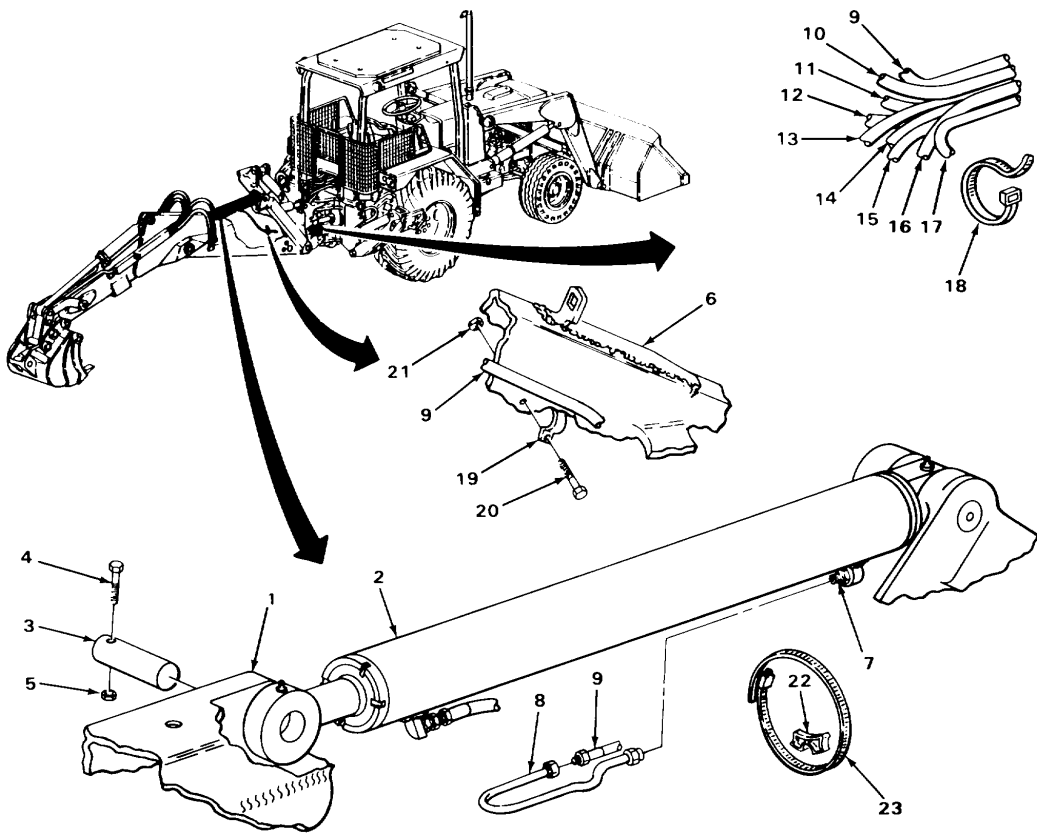

TA243494

MANIFOLD BLOCK-TO-CROWD CYLINDER OIL LINES (SERIAL NUMBERS 319995 THRU 342573 ONLY) - CONTINUED

LOCATION	ITEM	ACTION REMARKS
INSTALLATION - CONTINUED		
53. Loader backhoe	Engine	Start and run at high idle (TM 5-2420-222-10).
54.	Manifold block-to-crowd cylinder oil lines	a. Operate backhoe crowd controls and check for leaks. b. If leaking at any connection, tighten using 7/8-inch, two 1-inch, and 1 1/4-inch open-end wrenches. c. If leaking does not stop, shut down engine (TM 5-2420-222-10) and replace defective packing, fitting, tube, or hose as outlined in this task. d. If found leaking, repeat steps 52 thru 54.
55	Engine	If still running, shut down (TM 5-2420-222-10).

TASK ENDS HERE
MANIFOLD BLOCK-TO-BOOM BUCKET CYLINDER OIL LINES

This task covers:

- | | |
|---------------------------|---|
| a. Removal (page 2-1591) | c. Inspection/Replacement (page 2-1594) |
| b. Cleaning (page 2-1594) | d. Installation (page 2-1594) |

INITIAL SETUP:
Tools

Handle, ratchet, 3/8-inch drive
 Knife, pocket
 Pan, drain
 Pliers, diagonal-cutting
 Pliers, slip-joint
 Socket, 3/8-inch drive, 9/16-inch
 Wrench, open-end, 7/8-inch
 Wrench, open-end, 1-inch
 (two required)

Materials/Parts

Band, hoses
 Detergent, GP (item 7, Appendix C)
 Packing adapter-to-manifold
 Rags, wiping (item 21, Appendix C)
 Solvent, drycleaning (item 28, Appendix C)
 Tags, marking (item 30, Appendix C)

Personnel Required

One

2-1590

MANIFOLD BLOCK-TO-BOOM BUCKET CYLINDER OIL LINES - CONTINUED

LOCATION	ITEM	ACTION	REMARKS
----------	------	--------	---------

NOTE

Both manifold block-to-boom bucket cylinder oil lines are maintained the same way except as noted. Right oil line is shown. Repeat procedures as needed for left oil line.

REMOVAL

- | | | |
|--------------------------|------------------------------|--|
| 1. Loader backhoe | Boom, dipperstick and bucket | <ul style="list-style-type: none"> a. Extend as far as possible (TM 5-2420-222-10). b. Lower to ground so that boom and dipperstick are horizontal (TM 5-2420-222-10). |
| 2. | Hydraulic system | Release pressure (page 2-1191). |
| 3. Nine hoses (1 thru 9) | Band (10) | <ul style="list-style-type: none"> a. Using diagonal-cutting pliers, cut off. b. Get rid of. |

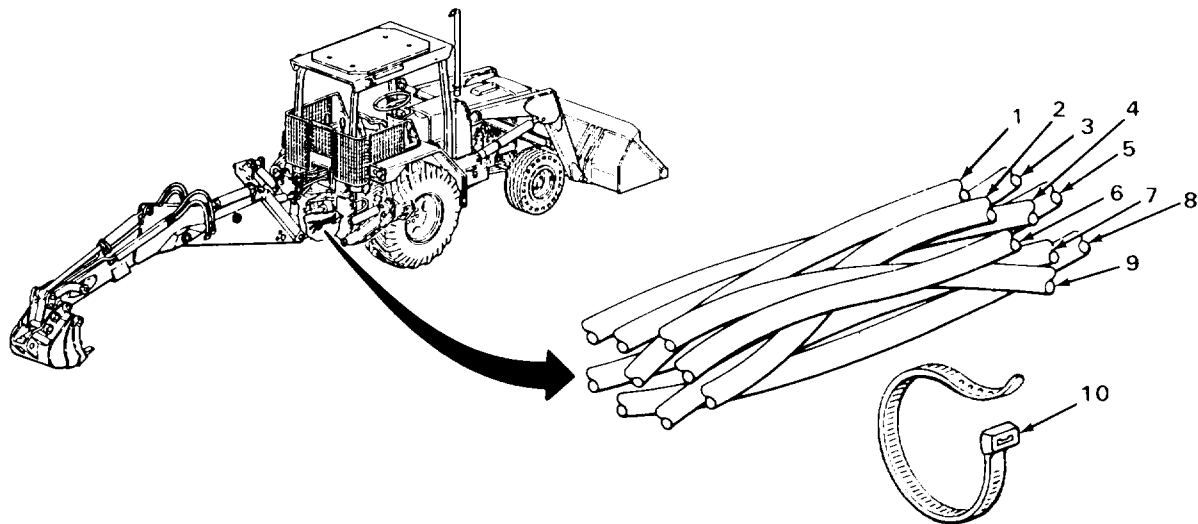

MANIFOLD BLOCK-TO-BOOM BUCKET CYLINDER OIL LINES - CONTINUED

LOCATION	ITEM	ACTION	REMARKS
----------	------	--------	---------

REMOVAL - CONTINUED

WARNING

Do not attempt to disconnect hydraulic lines and fittings while engine is running or before hydraulic system pressure has been released. When engine is running, hydraulic system is under pressure. Hydraulic system pressure should be 0 psi (0 kPa) before lines are disconnected. A line or fitting disconnected under pressure will blow off with a lot of force and could cause serious injury to personnel.

Be careful when draining hot fluids. Wear gloves to protect your hands from hot parts and fluids or severe burns could result.

NOTE

If right cylinder oil line is is being removed, skip step 4

- | | | |
|--------------|----------|---|
| 4. Union (1) | Hose (2) | <ul style="list-style-type: none"> a. Place drain pan underneath. b. Using two 1-inch open-end wrenches, unscrew and take out. c. Cap (page 2-137). d. Plug union (11)(page 2-137). e. Tag (page 2-137). |
|--------------|----------|---|

NOTE

If left cylinder oil line is is being removed, skip step 5

- | | | |
|-----------------------|-------------|---|
| 5. Union (3) | Hose (4) | <ul style="list-style-type: none"> a. Place drain pan underneath. b. Using 7/8-inch and 1-inch open-end wrenches, unscrew and take out. c. Cap (page 2-137). d. Plug union (12) (page 2-137). e. Tag (page 2-137). |
| 6. Adapter (5) | Hose (6) | <ul style="list-style-type: none"> a. Using 7/8-inch and 1-inch open-end wrenches, unscrew and take out. b. Tag (page 2-137). |
| 7. Manifold block (7) | Adapter (5) | <ul style="list-style-type: none"> a. Using 7/8-inch open-end wrench, unscrew and take out. b. Plug manifold block (14) (page 2-137). |
| 8. Adapter (5) | Packing (8) | <ul style="list-style-type: none"> a. Using pocket knife, take off. b. Get rid of. |

MANIFOLD BLOCK-TO-BOOM BUCKET CYLINDER OIL LINES - CONTINUED

LOCATION	ITEM	ACTION	REMARKS
REMOVAL - CONTINUED			
9. Boom (9), three clamps (10 thru 12) and spacer (13)	Screw (14)	Using 9/16-inch, 3/8-inch drive socket and ratchet handle, unscrew and take out.	
10. Boom (9) and four tubes (15 thru 18)	Three clamps (10 thru 12) and spacer (13)	Take off.	
11. Tube (15)	Hose (6)	a. Place drain pan underneath. b. Using 7/8-inch and 1-inch open-end wrenches, unscrew and take out. c. Tag (page 2-137). d. Plug tube (15) (page 2-137). e. Get rid of drained fluid (page 2-137).	

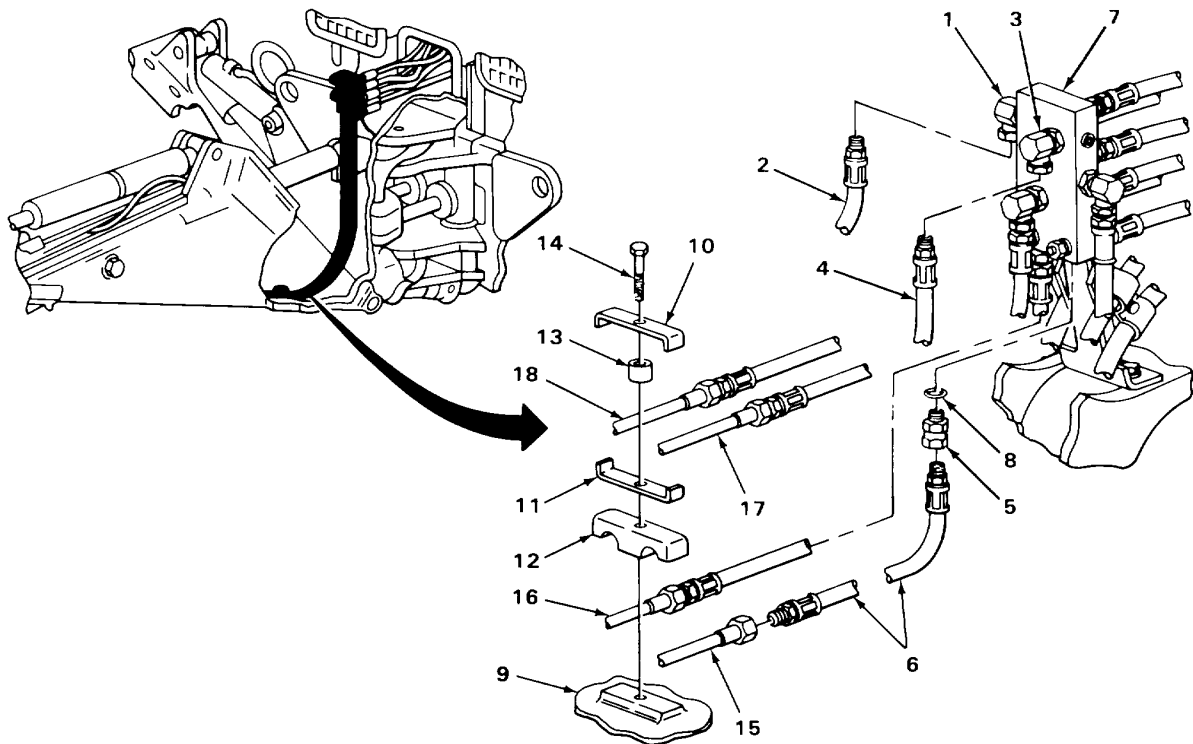

TA243496

MANIFOLD BLOCK-TO-BOOM BUCKET CYLINDER OIL LINES - CONTINUED

LOCATION	ITEM	ACTION	REMARKS
CLEANING			
NOTE			
For more information on how to clean parts, go to General Maintenance Instructions (page 2-137).			
12.	Hose (1)	<ul style="list-style-type: none"> a. Using clean rags dampened in solution of detergent and water, wipe clean. b. Rinse with clean water. c. Using clean, dry rags, wipe dry. 	
<u>WARNING</u>			
Drycleaning solvent P-D-680 is toxic and flammable. Wear protective goggles and gloves and use only in a well ventilated area. Avoid contact with skin, eyes, and clothes and don't breathe vapors. Do not use near open flame or excessive heat. The flashpoint is 100°F to 138°F (38° to 59°C). If you become dizzy while using cleaning solvent, get fresh air immediately and get medical aid. If contact with eyes is made, wash your eyes with water and get medical aid immediately.			
13. All metal parts		<ul style="list-style-type: none"> a. Clean in drycleaning solvent. b. Using clean, dry rags, wipe dry. 	
INSPECTION/REPLACEMENT			
NOTE			
For more information on how to inspect parts, go to General Maintenance Instructions (page 2-137).			
Replace defective parts as needed.			
14.	Hose (1)		Look for cuts, cracks, and breaks.
15.	All metal parts		Look for cracks, breaks, and abnormal bends.
16.	All threaded parts		Look for damaged threads.
INSTALLATION			
17. Tube (2)	Hose (1)	<ul style="list-style-type: none"> a. Take off tag. b. Unplug tube (2). c. Screw on and tighten using 7/8-inch and 1-inch open-end wrenches. 	

MANIFOLD BLOCK-TO-BOOM BUCKET CYLINDER OIL LINES - CONTINUED

LOCATION	ITEM	ACTION	REMARKS
18. Boom (3) and four tubes (2, 4, 5, and 6)	Three clamps (7 thru 9) and spacer (10)	Place in position.	
19. Three clamps (7 thru 9), spacer (10), and boom (3)	Screw (11)	Screw in and tighten using 9/16-inch, 3/8-inch drive socket and ratchet handle.	
20. Adapter (12)	New packing (13)	Place in position.	
21. Manifold block (14)	Adapter (12) with assembled packing (13)	a. Unplug manifold block (14). b. Screw in and tighten using 7/8-inch open-end wrench.	
22. Adapter(12)	Hose(1)	a. Take off tag. b. Screw in and tighten using 1-inch and 7/8-inch open-end wrenches.	

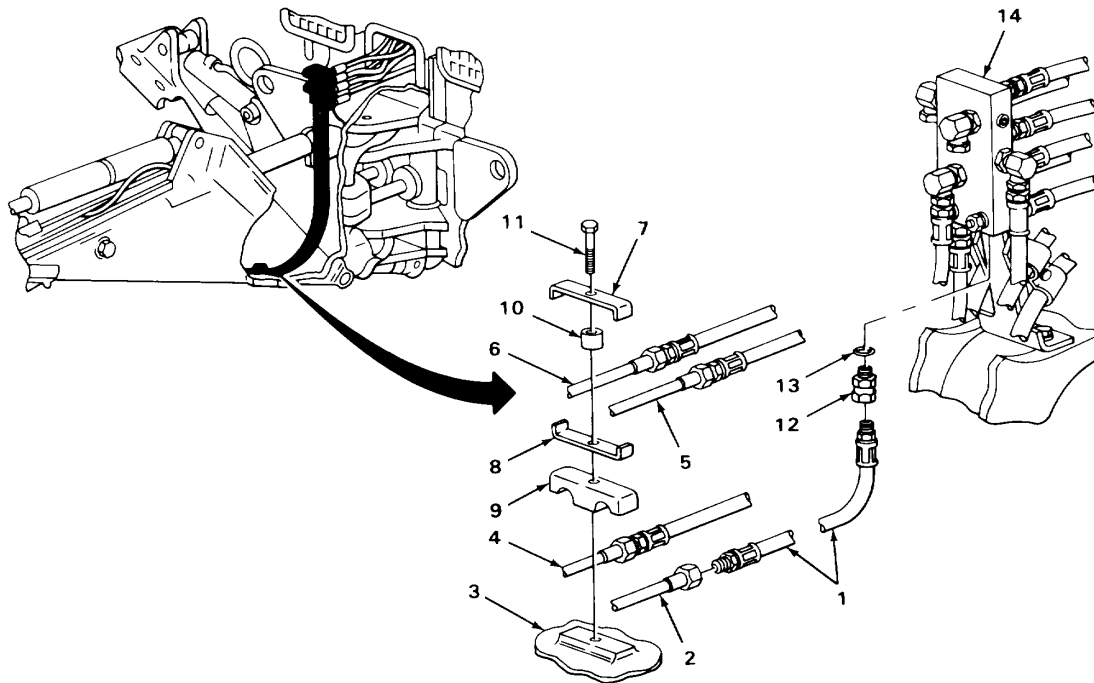

TA243497

MANIFOLD BLOCK-TO-BOOM BUCKET CYLINDER OIL LINES - CONTINUED

LOCATION	ITEM	ACTION	REMARKS
NOTE			
If installing left cylinder oil line, skip step 23.			
23. Union (1)	Hose (2)	<ul style="list-style-type: none"> a. Take off tag. b. Unplug union (1). c. Uncap. d. Screw in and tighten using 7/8-inch and 1-inch open-end wrenches. 	
NOTE			
If installing right cylinder oil line, skip step 24.			
INSTALLATION - CONTINUED			
24. Union (1)	Hose (2)	<ul style="list-style-type: none"> a. Take off tag. b. Unplug union (1). c. Uncap. d. Screw in and tighten using two 1-inch open-end wrenches. 	
25. Nine hoses (3 thru 10)	New band (12)	<ul style="list-style-type: none"> a. Place into position. b. Using slip-joint pliers, tighten until snug. 	
26. Loader backhoe	Transmission		Check fluid level and add proper amount and grade (TM 5-2420-222-10).
27.	Engine		Start and run at high idle (TM 5-2420-222-10).
28.	Manifold block-to-boom bucket cylinder oil lines	<ul style="list-style-type: none"> a. Operate backhoe boom (TM 5-2420-222-10) and check for leaks. b. If leaking at any connection, tighten using 7/8-inch and two 1-inch open-end wrenches. c. If leaking does not stop, shut down engine (TM 5-2420-222-10) and replace leaking connection packing, hose, or fitting as outlined in this task. d. If found leaking, repeat steps 26 thru 28. 	

MANIFOLD BLOCK-TO-BOOM BUCKET CYLINDER OIL LINES - CONTINUED

LOCATION	ITEM	ACTION	REMARKS
----------	------	--------	---------

29.

Engine

If still running, shut down
(TM 5-2420-222-10).

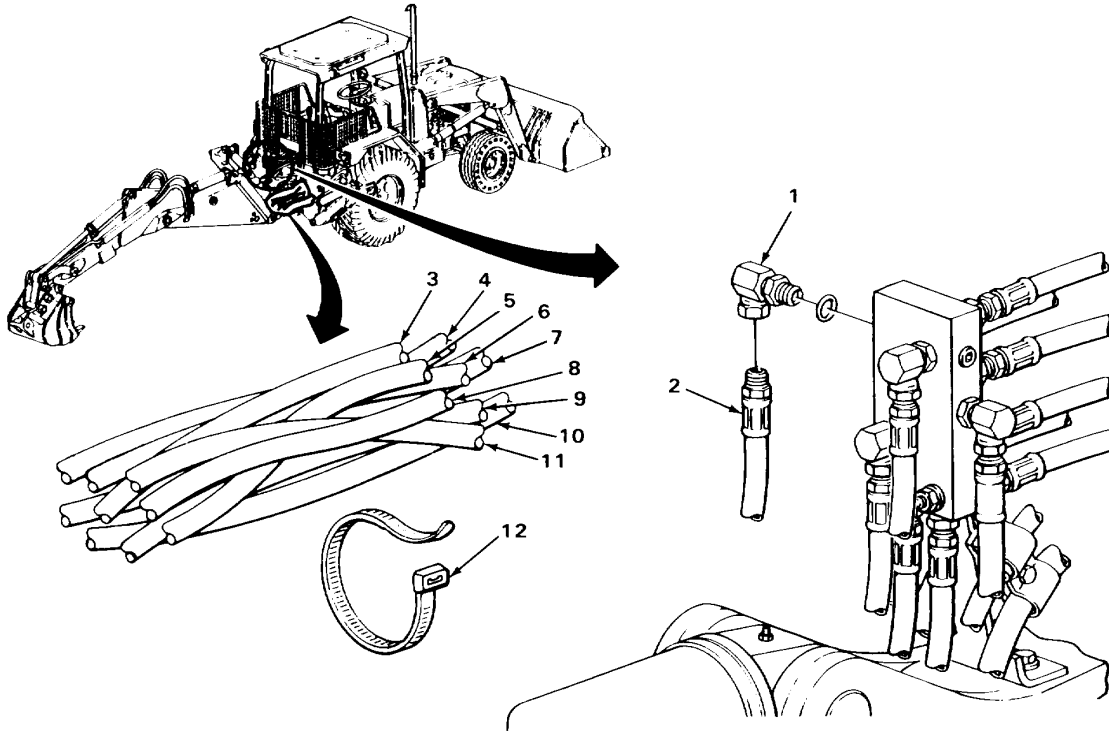

TASK ENDS HERE

BOOM-TO-BUCKET CYLINDER OIL LINES (SERIAL NUMBERS 235786 THRU 235999 ONLY)

This task covers:

- | | |
|---------------------------|---|
| a. Removal (page 2-1598) | c. Inspection/Replacement (page 2-1603) |
| b. Cleaning (page 2-1602) | d. Installation (page 2-1604) |

INITIAL SETUP:

Tools

- Handle, ratchet, 3/8-inch drive
- Knife, pocket
- Pan, drain
- Socket, 3/8-inch drive, 9/16-inch
- Wrench, open-end, 7/8-inch
- Wrench, open-end, 1-inch
- Wrench, open-end, 1 1/16-inch

Materials/Parts - Continued

- Packing, coupler (two required)
- Packing, cylinder-to-adapter (two required)
- Rags, wiping (item 21, Appendix C)
- Solvent, drycleaning (item 28, Appendix C)
- Tags, marking (item 30, Appendix C)

Personnel Required

Materials/Parts

One

- Detergent, GP (item 7, Appendix C)
- Lockwasher, clamp screw

LOCATION	ITEM	ACTION	REMARKS
----------	------	--------	---------

NOTE

Both boom-to-bucket cylinder oil lines are maintained the same way except as noted. One oil line is shown. Repeat procedures as needed for second oil line.

REMOVAL

- | | | |
|---|-------------------------------|--|
| 1. Loader backhoe | Boom, dipperstick, and bucket | <ul style="list-style-type: none"> a. Extend as far as possible (TM 5-2420-222-10). b. Lower to ground until boom and dipperstick are horizontal (TM 5-2420-222-10). |
| 2. | Hydraulic system | Release pressure (page 2-1191). |
| 3. Boom (1), three clamps (2 thru 4) and spacer (5) | Screw (6) | Using 9/16-inch, 3/8-inch drive socket and ratchet handle, unscrew and take out. |

BOOM-TO-BUCKET CYLINDER OIL LINES (SERIAL NUMBERS 235786 THRU 235999 ONLY) - CONTINUED

LOCATION	ITEM	ACTION	REMARKS
----------	------	--------	---------

4. Boom (1) and four tubes (7 thru 10)	Three clamps (2 thru 4) and spacer (5)	Take off.	
--	--	-----------	--

WARNING

Do not attempt to disconnect hydraulic lines and fittings while engine is running or before hydraulic system pressure has been released. When engine is running, hydraulic system is under pressure. Hydraulic system pressure should be 0 psi (0 kPa) before lines are disconnected. A line or fitting disconnected under pressure will blow off with a lot of force and could cause serious injury to personnel.

Be careful when draining hot fluids. Wear gloves to protect your hands from hot parts and fluids or severe burns could result.

5. Tube (7 or 8)	Hose (11 or 12)	a. Place drain pan underneath. b. Using 7/8-inch and 1-inch open-end wrenches, unscrew and take out. c. Cap (page 2-137). d. Tag (page 2-137).	
------------------	-----------------	---	--

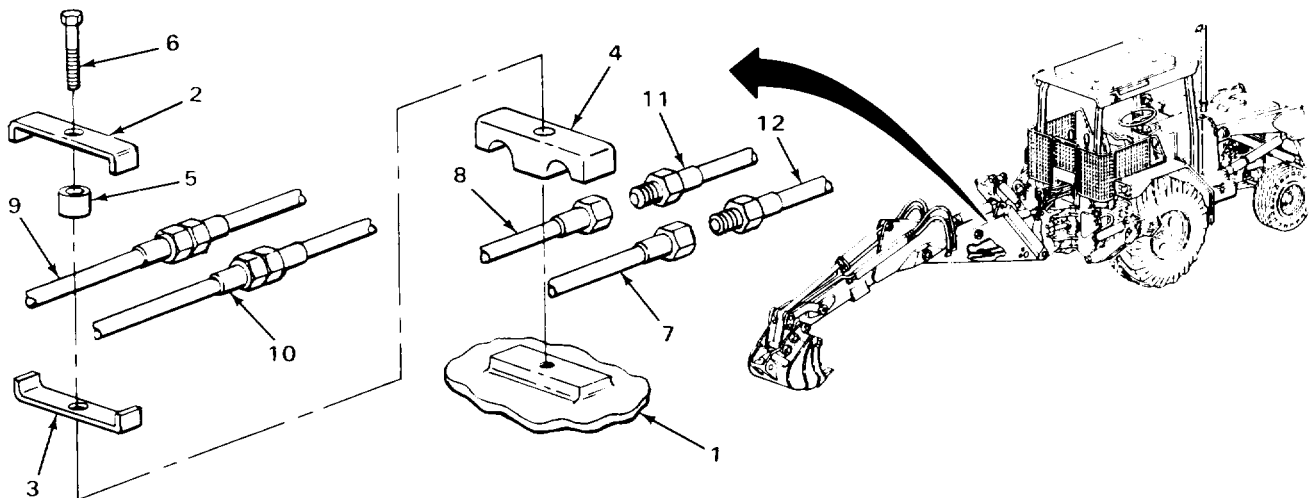

BOOM-TO-BUCKET CYLINDER OIL LINES (SERIAL NUMBERS 235786 THRU 235999 ONLY) - CONTINUED

LOCATION	ITEM	ACTION	REMARKS
REMOVAL - CONTINUED			
NOTE			
If removing boom-to-rod end bucket cylinder oil lines, skip steps 6 thru 8.			
6. Male nipple (1)	Quick coupler (2) with assembled parts	a. Place drain pan underneath. b. Pull off.	
7. Hose (3)	Quick coupler (2) with assembled packing (4)	Using 1-inch and 1 1/16-inch open-end wrenches, unscrew and take off.	
8. Quick coupler (2)	Packing (4)	a. Using pocket knife, take out. b. Get rid of.	
NOTE			
If removing boom-to-head end bucket cylinder oil line, skip steps 9 and 10.			
9. Quick coupler (5)	Male nipple (6) with assembled hose (7)	a. Place drain pan underneath. b. Pull out.	
10. Hose (7)	Male nipple (6)	Using 7/8-inch and 1 1/16-inch open-end wrenches, unscrew and take off.	
11. Boom (8), two spacers (9 and 10) and clamp (11)	Screw (12) and lockwasher (13)	a. Using 9/16-inch, 3/8-inch drive socket and ratchet handle, unscrew and take out. b. Get rid of lockwasher (13).	
12. Boom (8) and two tubes (14 and 15)	Clamp (11) and two spacers (9 and 10)	Take off.	
13. Tube (14 or 15)	Hose (3 or 7)	a. Place drain pan underneath. b. Using 7/8-inch and 1-inch open-end wrenches, unscrew and take out.	
14. Dipperstick (16)	Hose (3 or 7)	a. Note relative position for proper placement during installation. b. Take out. c. Tag (page 2-137).	

BOOM-TO-BUCKET CYLINDER OIL LINES (SERIAL NUMBERS 235786 THRU 235999 ONLY) - CONTINUED

LOCATION	ITEM	ACTION	REMARKS
15. Boom (8)	Tube (14 or 15)	a. Take out. b. Tag (page 2-137).	
NOTE			
If removing boom-to-rod end bucket cylinder oil line, skip steps 16 thru 18.			
16 Adapter(17)	Male nipple (1)	Using 1 1/16-inch open-end wrench, unscrew and take off.	
17. Bucket cylinder (18)	Adapter (17) with assembled take out. packing (19)		a. Using open-end wrench, unscrew and b. Plug cylinder (18) (page 2-137).
18. Adapter (17)	Packing (19)	a. Using pocket knife, take off. b. Get rid of.	

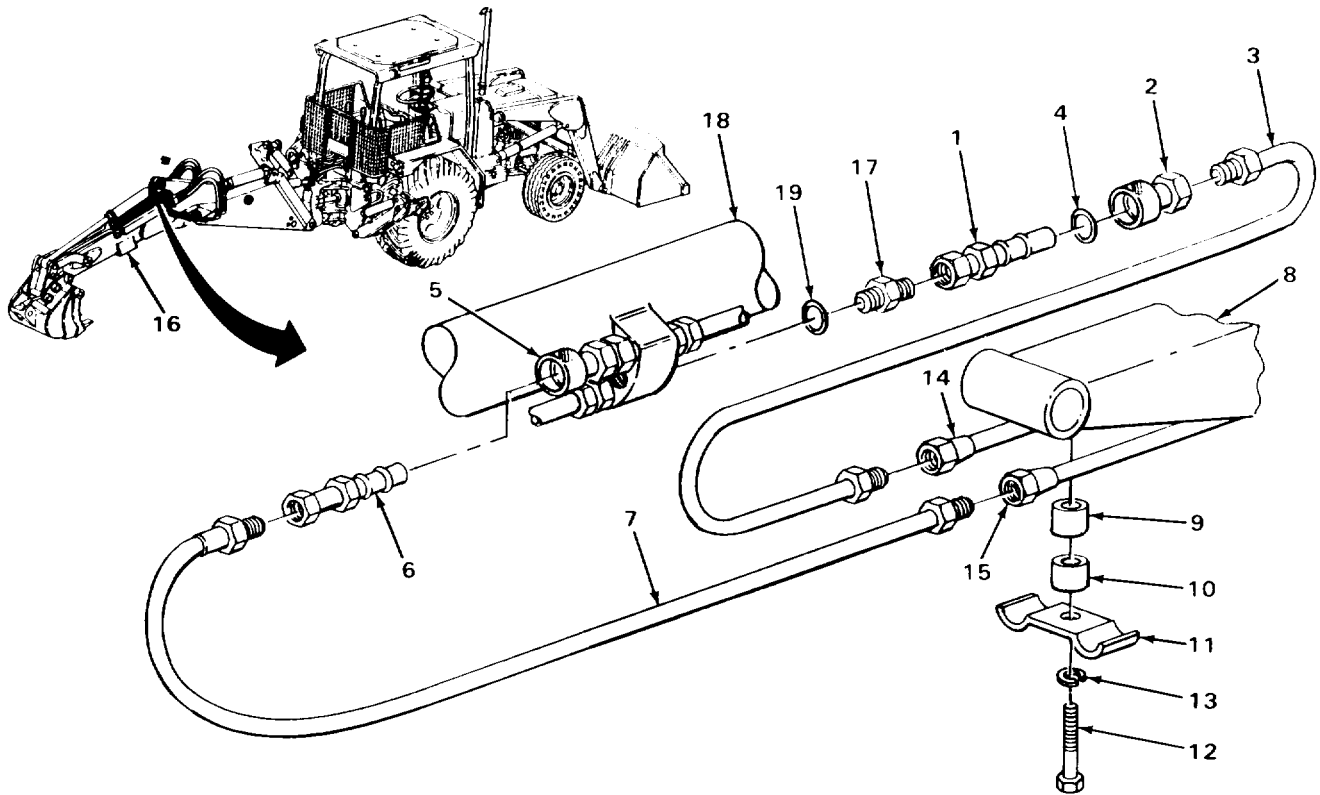

TA243500

BOOM-TO-BUCKET CYLINDER OIL LINES (SERIAL NUMBERS 235786 THRU 235999 ONLY) - CONTINUED

LOCATION	ITEM	ACTION	REMARKS
REMOVAL-CONTINUED			
NOTE			
If removing boom-to-head end bucket cylinder oil line, skip step 19 thru 22.			
19. Adapter (1)	Quick coupler (2) with assembled packing (3)	Using 1 1/16-inch open-end wrench, un- screw and take off.	
20. Quick coupler (2)	Packing (3)	a. Using pocket knife, take out. b. Get rid of.	
21. Bucket cylinder (4)	Adapter (1) with assembled packing (5)	a. Using open-end wrench, unscrew and take out. b. Plug cylinder (4) (page 2-137).	
22. Adapter (1)	Packing (5)	a. Using pocket knife, take off. b. Get rid of.	

CLEANING**NOTE**

For more information on how to clean parts, go to General Maintenance Instructions (page 2-137).

23	Hose (6 or 7)	a. Using clean rags dampened with solution of detergent and water, wipe clean. b. Rinse with clean water. c. Using clean, dry rags, wipe dry.	
----	---------------	--	--

WARNING

Drycleaning solvent P-D-680 is toxic and flammable. Wear protective goggles and gloves and use only in a well ventilated area. Avoid contact with skin, eyes, and clothes and don't breathe vapors. Do not use near open flame or excessive heat. The flashpoint is 100°F to 138°F (38° to 59°C). If you become dizzy while using cleaning solvent, get fresh air immediately and get medical aid. If contact with eyes is made, wash your eyes with water and get medical aid immediately.

24 .	Tube (8 or 9)	a. Using clean rags dampened in dry- cleaning solvent, wipe clean. b. Using clean, dry rags, wipe dry.	
------	---------------	--	--

BOOM-TO-BUCKET CYLINDER OIL LINES (SERIAL NUMBERS 235786 THRU 235999 ONLY) - CONTINUED

LOCATION	ITEM	ACTION	REMARKS
25.	All other metal parts	a. Clean in dry cleaning solvent. b. Using clean, dry rags, wipe dry.	

INSPECTION/REPLACEMENT

NOTE

For more information on how to inspect parts, go to **General Maintenance Instructions (page 2-137)**.

Replace defective parts as needed.

26.	Hose (6 or 7)	Look for cuts, cracks, and breaks.
27.	All metal parts	Look for cracks, breaks, and abnormal bends.
28.	All threaded parts	Look for damaged threads.

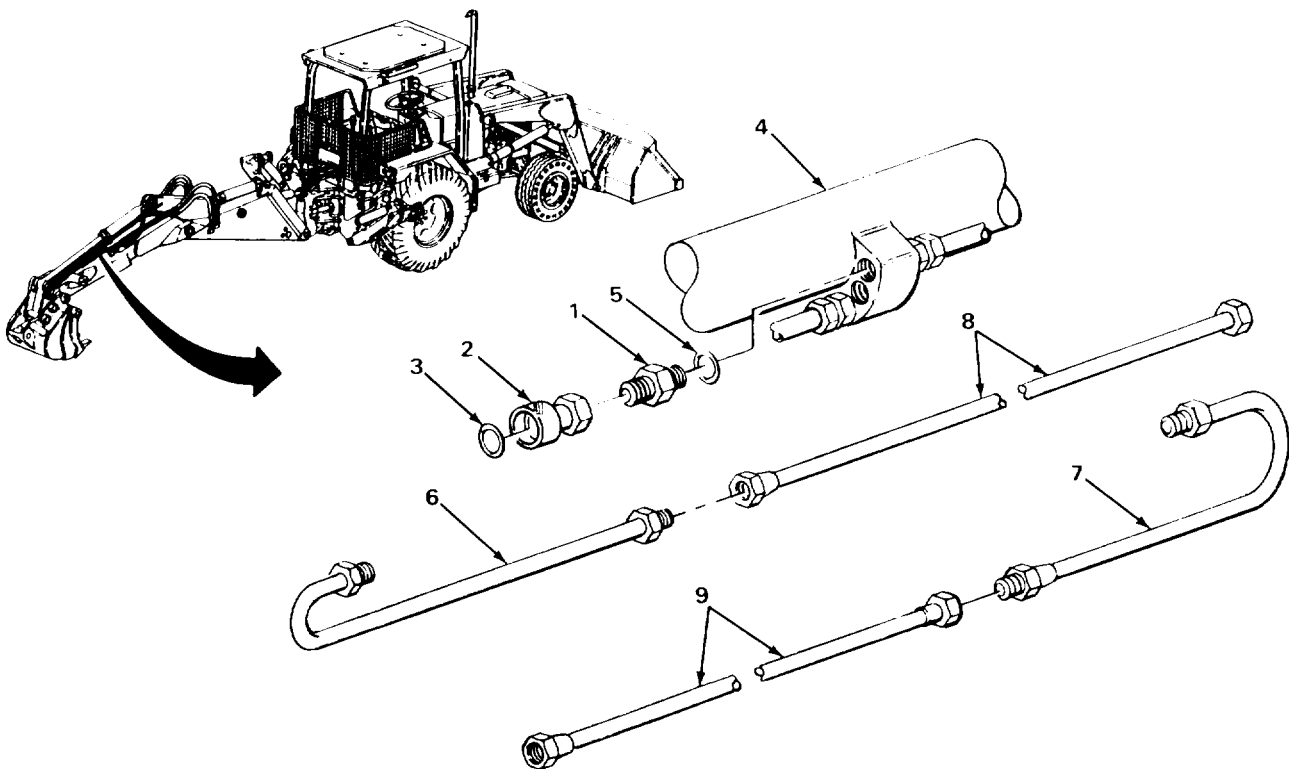

**BOOM-TO-BUCKET CYLINDER OIL LINES (SERIAL NUMBERS 235786 THRU 235999 ONLY) -
CONTINUED**

LOCATION	ITEM	ACTION	REMARKS
INSTALLATION			
NOTE			
If installing boom-to-head end bucket cylinder oil line, skip steps 29 thru 32.			
29.	Adapter (1)	New packing (2)	Place in position.
30.	Bucket cylinder (3)	Adapter (1) with assembled packing (2)	a. Unplug cylinder(3). b. Screw on and tighten using open-end wrench.
31.	Quick coupler (4)	New packing (5)	Place in position.
32.	Adapter (1)	Quick coupler (4) with assembled packing (5)	Screw on and tighten using 1 1/16-inch open-end wrench.
NOTE			
If installing boom-to-rod end bucket cylinder oil line, skip steps 33 thru 35.			
33.	Adapter (6)	New packing (7)	Place in position.
34.	Bucket cylinder (3)	Adapter (6) with assembled packing (7)	a. Unplug cylinder (3). b. Screw on and tighten using open-end wrench.
35.	Adapter (6)	Male nipple (8)	Screw on and tighten using 1 1/16-inch open-end wrench.
36.	Boom (9)	Tube (10 or11)	a. Takeoff tag. b. Place in position.
37.	Dipperstick (12)	Hose (13 or 14)	a. Take off tag. b. Place in same relative position noted during removal.
38.	Tube (10 or 11)	Hose (13 or 14)	Screw in and tighten using 7/8-inch and and 1-inch open-end wrenches.
39.	Boom (9) and two tubes (10 and 11)	Clamp (15) and two spacers (16 and 17)	Place in position.

BOOM-TO-BUCKET CYLINDER OIL LINES (SERIAL NUMBERS 235786 THRU 235999 ONLY) -CONTINUED

LOCATION	ITEM	ACTION	REMARKS
----------	------	--------	---------

40. Boom (9), two spacers (16 and 17), and clamp (15)	Screw (18) and new lockwasher (19)	Screw in and tighten using 9/16-inch, 3/8-inch drive socket and ratchet handle.
---	------------------------------------	---

NOTE

If installing boom-to-head end bucket cylinder oil line, skip steps 41 and 42.

41. Hose (13)	Male nipple (20)	Screw on and tighten using 7/8-inch and 1 1/16-inch open-end wrenches.
42. Quick coupler (4)	Male nipple (20) with assembled hose (13)	Snap in.

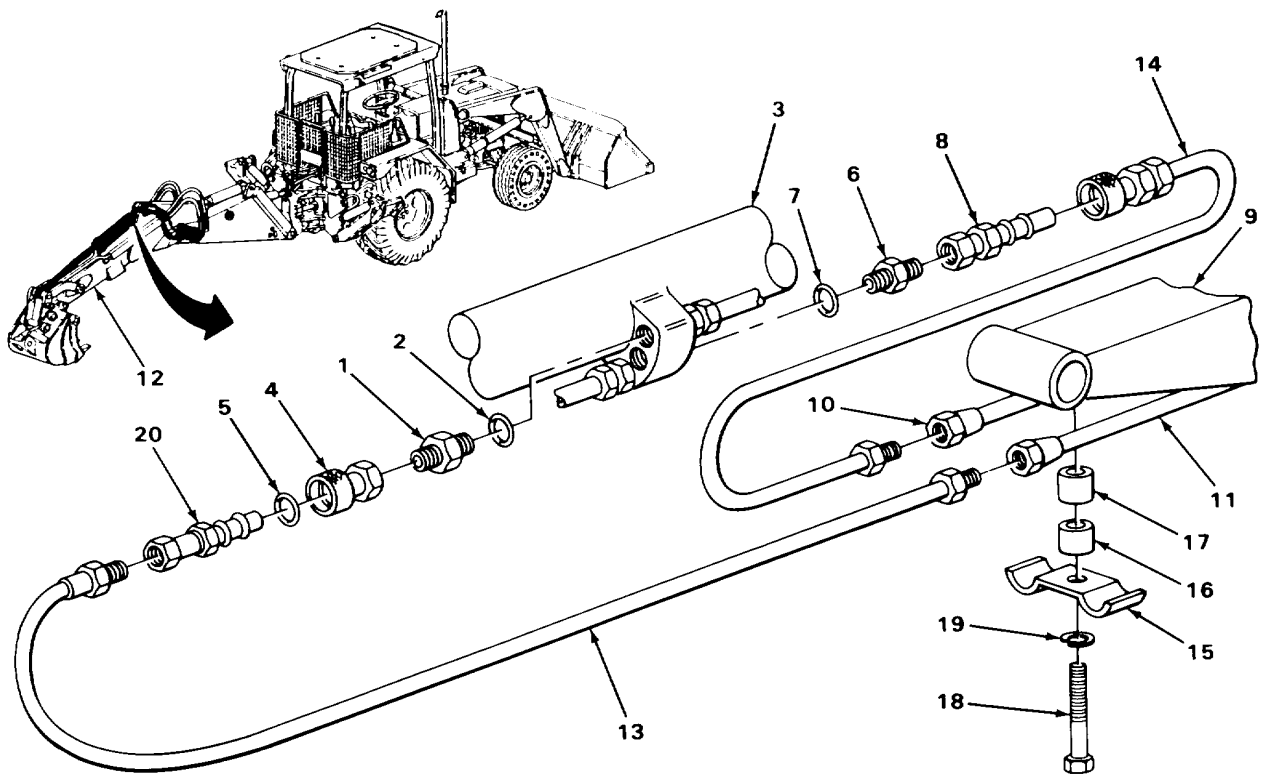

BOOM-TO-BUCKET CYLINDER OIL LINES (SERIAL NUMBERS 235786 THRU 235999 ONLY) - CONTINUED

LOCATION	ITEM	ACTION	REMARKS
INSTALLATION - CONTINUED			
NOTE			
If installing boom-to-rod end bucket cylinder oil line, skip steps 43 and 45.			
43.	Hose (1)	Quick coupler (2)	Screw on and tighten using 1-inch and 1 1/16-inch open-end wrenches.
44.	Quick coupler (2)	New packing (3)	Place in position.
45.	Male nipple (4)	Quick coupler (2) with assembled parts	Snap on.
46.	Tube (5 or 6)	Hose (7 or 8)	a. Uncap. b. Take off tag. c. Screw in and tighten using 7/8-inch and 1-inch open-end wrenches.
47.	Boom (9) and four tubes (5, 6, 10, and 11)	Three clamps (12 thru 14) and spacer (15)	Place in position.
48.	Boom (9), three clamps (12 thru 14), and spacer (15)	Screw (16)	Screw in and tighten using 9/16-inch, 3/8-inch drive socket and ratchet handle.
49.	Loader backhoe	Transmission	Check fluid level and add proper amount and grade (TM 5-2420-222-10).
50.		Engine	Start and run at high idle (TM 5-2420-222-10).
51.		Boom-to-bucket cylinder oil lines	a. Operate backhoe bucket (TM 5-2420-222-10) and check for leaks. b. If leaking at any connection, tighten using 7/8-inch, 1-inch, and 1 1/16-inch open-end wrenches. c. If leaking does not stop, shut down engine (TM 5-2420-222-10) and replace leaking connection packing, fitting, or hose as outlined in this task. d. If found leaking, repeat steps 49 thru 51.

BOOM-TO-BUCKET CYLINDER OIL LINES (SERIAL NUMBERS 235786 THRU 235999 ONLY) - CONTINUED

LOCATION	ITEM	ACTION	REMARKS
----------	------	--------	---------

52.

Engine

If still running, shut down
(TM 5-2420-222-10).

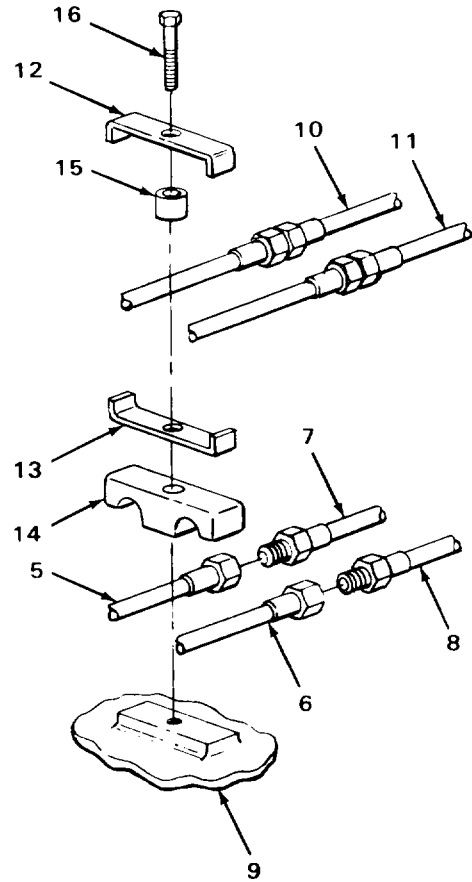
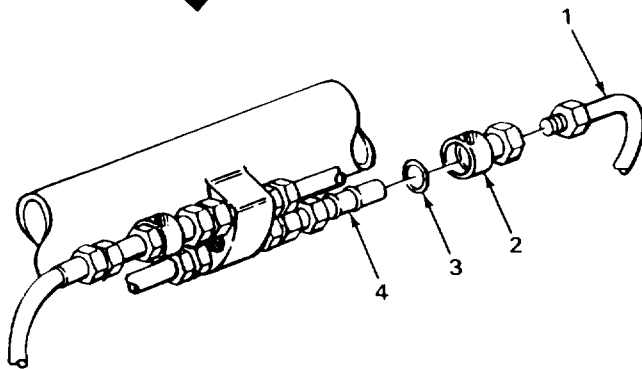
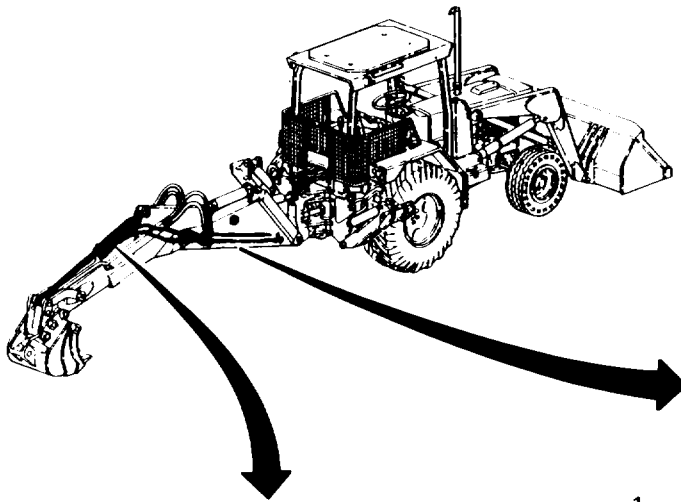

TASK ENDS HERE

TA243503

BOOM-TO-BUCKET CYLINDER OIL LINES (SERIAL NUMBERS 319995 THRU 342573 ONLY)

This task covers:

- a. Removal (page 2-1608)
- b. Cleaning (page 2-1614)
- c. Inspection/Replacement (page 2-1615)
- d. Installation (page 2-1615)

INITIAL SETUP:

Tools

- Blocks, wood
- Driftpin, brass-tipped, 3/4-inch
- Hammer, ball-peen, 2-pound head
- Handle, ratchet, 3/8-inch drive
- Handle, ratchet, 1/2-inch drive
- Knife, pocket
- Lifting equipment, 200-pound capacity
- Pan, drain
- Screwdriver, flat-tip, 1/4-inch
- Socket, 3/8-inch drive, 9/16-inch
- Socket, 1/2-inch drive, 3/4-inch
- Wrench, open-end, 3/4-inch
- Wrench, open-end, 7/8-inch
- Wrench, open-end, 1-inch (two required)
- Wrench, open-end, 1 1/16-inch

Materials/Parts

- Detergent, GP (item 7, Appendix C)
- Lockwasher, clamp screw
- Nut, stop, pin screw
- Packing, adapter
- Packing, connector
- Rags, wiping (item 21, Appendix C)
- Solvent, dry-cleaning (item 28, Appendix C)
- Tags, marking (item 30, Appendix C)

Personnel Required

One

LOCATION	ITEM	ACTION	REMARKS
----------	------	--------	---------

NOTE

Both boom-to-bucket cylinder oil lines are maintained the same way except as noted. One side is shown. Repeat procedures as needed for other oil line.

REMOVAL

- | | | | |
|----|--|-------------------------------|--|
| 1. | Loader backhoe | Boom, dipperstick, and bucket | <ul style="list-style-type: none"> a. Extend as far as possible (TM 5-2420-222-10). b. Lower to ground so that boom and dipperstick are horizontal (TM 5-2420-222-10). |
| 2. | | Hydraulic system | Release pressure (page 2-1191). |
| 3. | Boom (1), three clamps (2 thru 4) and spacer (5) | Screw (6) | Using 9/16-inch, 3/8-inch drive socket and ratchet handle, unscrew and take out. |

BOOM-TO-BUCKET CYLINDER OIL LINES (SERIAL NUMBERS 319995 THRU 342573 ONLY) - CONTINUED

LOCATION	ITEM	ACTION	REMARKS
----------	------	--------	---------

4.	Boom (1) and four tubes (7 thru 10)	Three clamps (2 thru 4) and spacer (5)	Take off.
----	-------------------------------------	--	-----------

WARNING

Do not attempt to disconnect hydraulic lines and fittings while engine is running or before hydraulic system pressure has been released. When engine is running, hydraulic system is under pressure. Hydraulic system pressure should be 0 psi (0 kPa) before lines are disconnected. A line or fitting disconnected under pressure will blow off with a lot of force and could cause serious injury to personnel.

Be careful when draining hot fluids. Wear gloves to protect your hands from hot parts and fluids or severe burns could result.

5.	Tube (7 or 8)	Hose (11 or 12)	<ul style="list-style-type: none"> a. Place drain pan underneath. b. Using 7/8-inch and 1-inch open-end wrenches, unscrew and take out. c. Cap (page 2-137). d. Tag (page 2-137).
----	---------------	-----------------	---

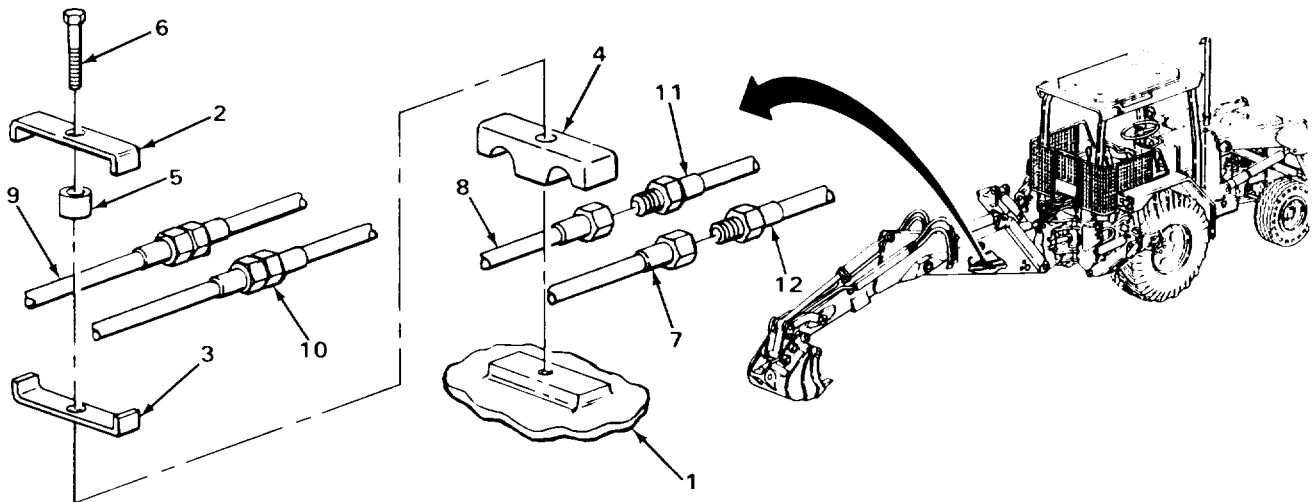

BOOM-TO-BUCKET CYLINDER OIL LINES (SERIAL NUMBERS 319995 THRU 342573 ONLY) - CONTINUED

LOCATION	ITEM	ACTION REMARKS
REMOVAL - CONTINUED		
6. Bucket cylinder (1), two spacers (2), and tube (3)	Clamp (4)	Using 1/4-inch flat-tip screwdriver, unscrew and take off.
7. Bucket cylinder (1), tube (3), and quick coupler (5)	Two spacers (2)	a. Note relative position for proper placement during installation. b. Take off.
NOTE		
If removing boom-to-head end bucket cylinder oil line, skip steps 8 and 9.		
8. Quick coupler (5)	Male nipple (6) with assembled hose (7)	a. Place drain pan underneath. b. Pull out.
9. Hose (7)	Male nipple (6)	Using 7/8-inch and 1 1/16-inch open-end wrenches, unscrew and take off.
NOTE		
If removing boom-to-rod end bucket cylinder oil line, skip steps 10 and 11.		
10. Male nipple (8)	Quick coupler (9) with assembled hose (10)	a. Place drain pan underneath. b. Pull off.
11. Hose (10)	Quick coupler (9)	Using 7/8-inch and 1 1/16-inch open-end wrenches, unscrew and take off.
12. Boom (11), two spacers (12 and 13), and clamp (14)	Screw (15) and lockwasher (16)	a. Using 9/16-inch, 3/8-inch drive socket and ratchet handle, unscrew and take out. b. Get rid of lockwasher (16).
13. Boom (11) and two tubes (17 and 18)	Clamp (14) and two spacers (12 and 13)	Take off.
14. Tube (17 or 18)	Hose (7 or 10)	a. Place drain pan underneath. b. Using 7/8-inch and 1-inch open-end wrenches, unscrew and take out.

BOOM-TO-BUCKET CYLINDER OIL LINES (SERIAL NUMBERS 319995 THRU 342573 ONLY) - CONTINUED

LOCATION	ITEM	ACTION REMARKS
15. Dipperstick (19)	Hose (7 or 10)	a. Note relative position for proper placement during installation. b. Take out. c. Tag (page 2-137).
16. Boom (11)	Tube (17 or 18)	a. Note relative position for proper placement during installation. b. Take out. c. Tag (page 2-137).

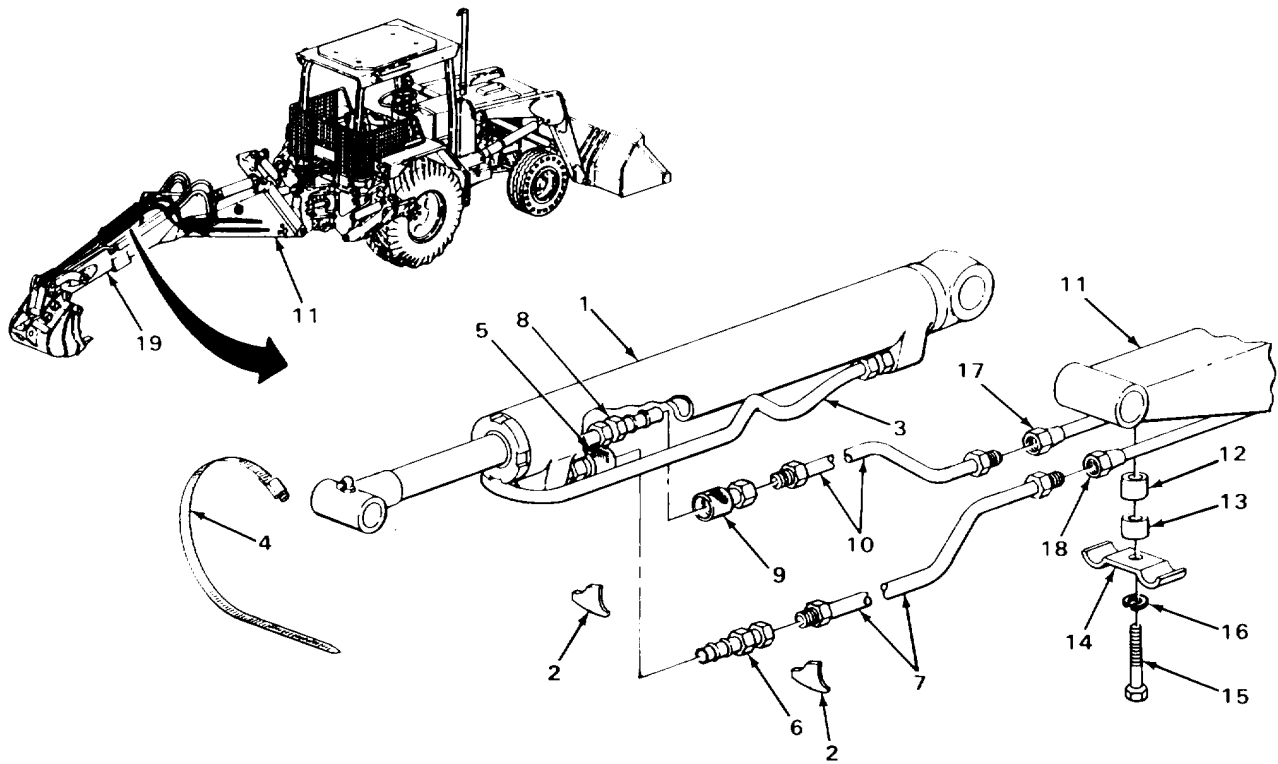

2-1611

TA243505

BOOM-TO-BUCKET CYLINDER OIL LINES (SERIAL NUMBERS 319995 THRU 342573 ONLY) - CONTINUED

LOCATION	ITEM	ACTION	REMARKS
----------	------	--------	---------

REMOVAL - CONTINUED

NOTE

If removing boom-to-rod end bucket cylinder oil line, skip step 17.

17. Tube (1)	Male nipple (2)	a. Using 7/8-inch and 1 1/16-inch open-end wrenches, unscrew and take off. b. Get rid of drained fluid (page 2-137).	
--------------	-----------------	---	--

NOTE

If removing boom-to-head end bucket cylinder oil line, skip step 18.

18. Adapter (3)	Quick coupler (4)	a. Using 1-inch and 1 1/16-inch open-end wrenches, unscrew and take off. b. Get rid of drained fluid (page 2-137).	
-----------------	-------------------	---	--

NOTE

Bucket cylinder must be disconnected to remove head end tube and connector or rod end adapter. Do not remove these parts unless inspection shows need for replacement. If these parts are not being removed, skip steps 19 thru 21.

19. Dipperstick (5) and pin (6)	Screw (7) and stop nut (8)	a. Using 3/4-inch, 1/2-inch drive socket, ratchet handle, and 3/4-inch open-end wrench, unscrew and take apart. b. Get rid of stop nut (8).	
---------------------------------	----------------------------	--	--

WARNING

Some parts are heavy. Be careful when handling them. Lifting equipment is needed when parts weigh over 50 pounds (23 kg) for a single person lift, over 100 pounds (45 kg) for a two person lift, and over 150 pounds (68 kg) for a three or more person lift. Do not try to handle heavy parts without lifting equipment. Keep clear of heavy parts supported only by lifting equipment. Failure to observe this precaution could cause serious injury or death of personnel.

20. Dipperstick (5) and bucket cylinder (9)	Pin (6)	a. Using 200-pound capacity lifting equipment, support cylinder (9). b. Using 3/4-inch brass-tipped driftpin and 2-pound head ball-peen hammer, drive out.	
---	---------	---	--

BOOM-TO-BUCKET CYLINDER OIL LINES (SERIAL NUMBERS 319995 THRU 342573 ONLY) - CONTINUED

LOCATION	ITEM	ACTION	REMARKS
21. Dipperstick (5) and guide link (10)	Bucket cylinder (9)	a. Using 200-pound capacity lifting equipment, pivot away from dipperstick (5) far enough to access tube (1), connector (11), or adapter (3). b. Place wood blocks in position to support. c. Using 200-pound capacity lifting equipment lower on to wood blocks.	

NOTE

If removing boom-to-rod end bucket cylinder oil line, skip steps 22 thru 24.

22. Connector (11)	Tube (1)	a. Note relative position for proper placement during installation. b. Using two 1-inch open-end wrenches, unscrew and take off.	
--------------------	----------	---	--

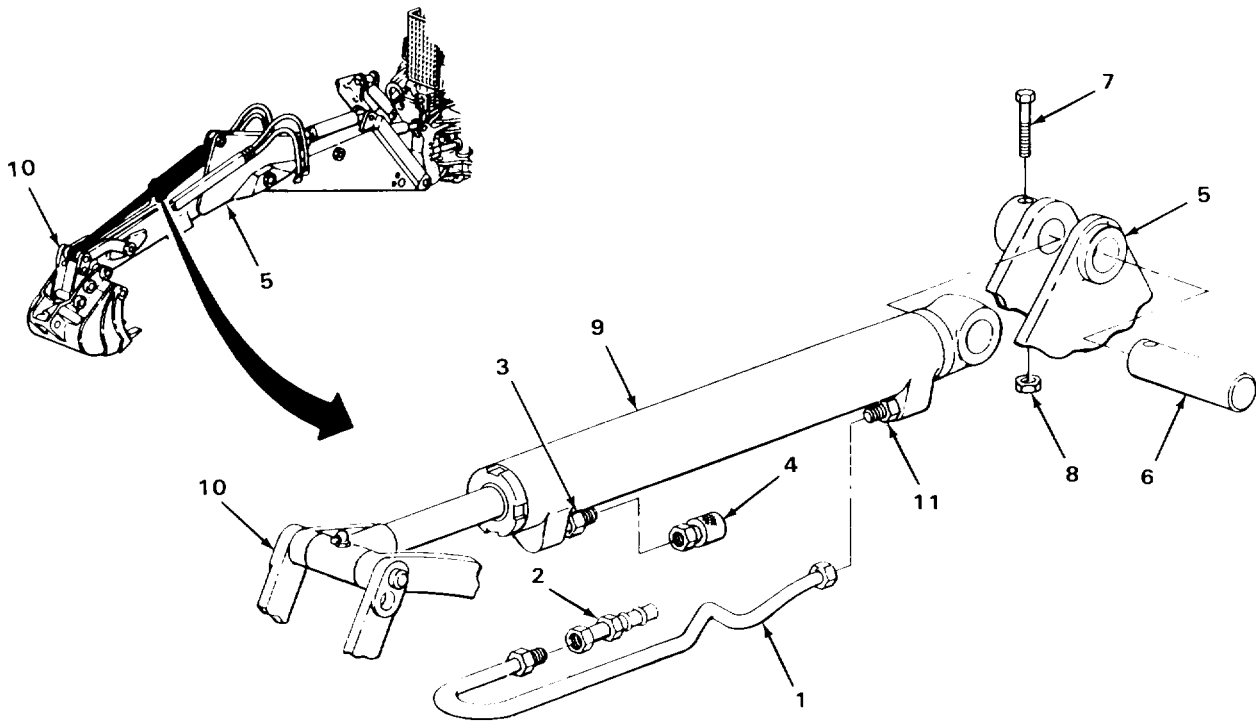

BOOM-TO-BUCKET CYLINDER OIL LINES (SERIAL NUMBERS 319995 THRU 342573 ONLY) - CONTINUED

LOCATION	ITEM	ACTION	REMARKS
REMOVAL - CONTINUED			
23.	Bucket cylinder (1)	Connector (2) with assembled packing (3)	a. Using 1-inch open-end wrench, unscrew and take out. b. Plug cylinder (page 2-137).
24.	Connector (2)	Packing (3)	a. Using pocket knife, take off. b. Get rid of.

NOTE

If removing boom-to-head end bucket cylinder oil line, skip steps 25 and 26.

25.	Bucket cylinder (1)	Adapter (4) with assembled packing (5)	a. Using 1-inch open-end wrench, unscrew and take out. b. Plug cylinder (1) (page 2-137).
26.	Adapter (4)	Packing (5)	a. Using pocket knife, take off. b. Get rid of.

CLEANING**NOTE**

For more information on how to clean parts, go to General Maintenance Instructions (page 2-137).

27.	Hose (6 or 7)	a. Using clean rags dampened in solution of detergent and water, wipe clean. b. Rinse with clean water. c. Using clean, dry rags, wipe dry.
-----	---------------	---

WARNING

Dry-cleaning solvent P-D-680 is toxic and flammable. Wear protective goggles and gloves and use only in a well ventilated area. Avoid contact with skin, eyes, and clothes and don't breathe vapors. Do not use near open flame or excessive heat. The flashpoint is 100°F to 138°F (38° to 59°C). If you become dizzy while using cleaning solvent, get fresh air immediately and get medical aid. If contact with eyes is made, wash your eyes with water and get medical aid immediately.

28.	Tubes (8 or 9)	a. Using clean rags dampened in dry-cleaning solvent, wipe clean. b. Using clean, dry rags, wipe dry.
-----	----------------	--

BOOM-TO-BUCKET CYLINDER OIL LINES (SERIAL NUMBERS 319995 THRU 342573 ONLY) - CONTINUED

LOCATION	ITEM	ACTION	REMARKS
29.	All other metal parts	a. Clean in dry-cleaning solvent. b. Using clean, dry rags, wipe dry.	

INSPECTION/REPLACEMENT

NOTE

For more information on how to inspect parts, go to General Maintenance Instructions (page 2-137).

Replace defective parts as needed.

30.	Hose (6 or 7)	Look for cuts, cracks, and breaks.
31.	All metal parts	Look for cracks, breaks, and abnormal bends.
32.	All threaded parts	Look for damaged threads.

INSTALLATION

NOTE

If installing boom-to-head end bucket cylinder oil line or if rod end adapter was not removed, skip steps 33 and 34.

33.	Adapter (4)	New packing (5)	Place in position.
-----	-------------	-----------------	--------------------

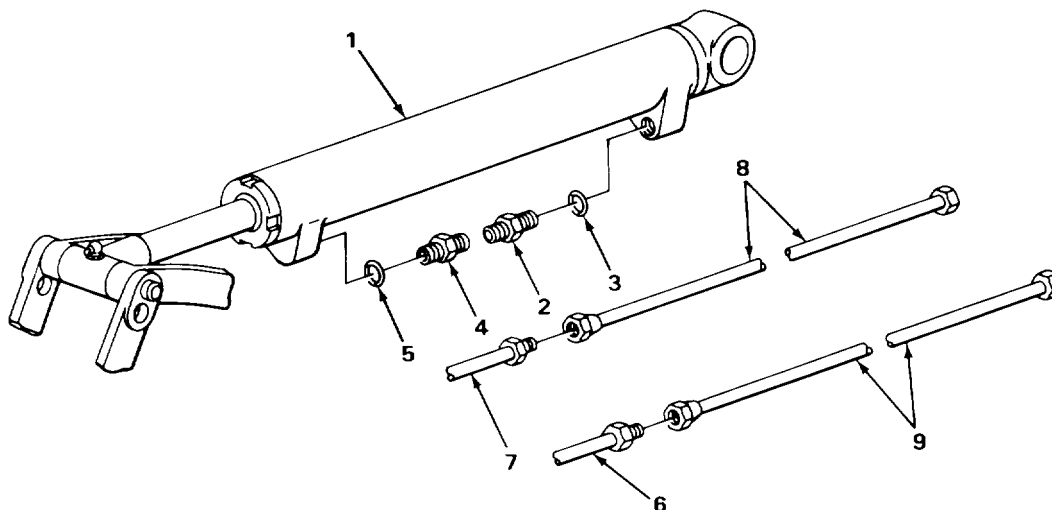

TA243507

BOOM-TO-BUCKET CYLINDER OIL LINES (SERIAL NUMBERS 319995 THRU 342573 ONLY) - CONTINUED

LOCATION	ITEM	ACTION	REMARKS
INSTALLATION - CONTINUED			
34.	Bucket cylinder (1)	Adapter (2) with assembled packing (3)	a. Unplug cylinder (1). b. Screw on and tighten using 1-inch open-end wrench.
NOTE			
If installing boom-to-rod end bucket cylinder oil line or if head end connector and tube were not removed, skip steps 35 thru 37.			
35.	Connector (4)	New packing (5)	Place in position.
36.	Bucket cylinder (1)	Connector (4) with assembled packing (5)	a. Unplug cylinder (1). b. Screw in and tighten using 1-inch open-end wrench.
37.	Connector (4)	Tube (6)	Screw on and tighten to same relative position noted during assembly using two 1-inch open-end wrenches.
NOTE			
If bucket cylinder head end connector and tube or rod end adapter were not removed, skip steps 38 thru 40.			
<u>WARNING</u>			
Some parts are heavy. Be careful when handling them. Lifting equipment is needed when parts weigh over 50 pounds (23 kg) for a single person lift, over 100 pounds (45 kg) for a two person lift, and over 150 pounds (68 kg) for a three or more person lift. Do not try to handle heavy parts without lifting equipment. Keep clear of heavy parts supported only by lifting equipment. Failure to observe this precaution could cause serious injury or death of personnel.			
38.	Dipperstick (7) and guide link (8)	Bucket cylinder (1)	a. Using 200-pound capacity lifting equipment, raise off wood blocks. b. Take out wood blocks. c. Using 200-pound capacity lifting equipment, lower into position aligning pin holes.
39.	Bucket cylinder (1) and dipperstick (7)	Pin (9)	a. Using 2-pound head ball-peen hammer, tap into position aligning pin holes. b. Disconnect 200-pound capacity lifting equipment.

BOOM-TO-BUCKET CYLINDER OIL LINES (SERIAL NUMBERS 319995 THRU 342573 ONLY) - CONTINUED

LOCATION	ITEM	ACTION REMARKS
40. Dipperstick (7) and pin (9)	Screw (10) and new stop nut (11)	Screw together and tighten using 3/4- inch, 1/2-inch drive socket, ratchet handle, and 3/4-inch open-end wrench.
NOTE		
If installing boom-to-head end bucket cylinder oil line, skip step 41.		
41. Adapter (2)	Quick coupler (12)	Screw on and tighten using 1-inch and 1 1/16-inch open-end wrenches.
NOTE		
If installing boom-to-rod end bucket cylinder oil line, skip step 42.		
42. Tube (6)	Male nipple (13)	Screw on and tighten using 1-inch and 1 1/16-inch open-end wrenches.

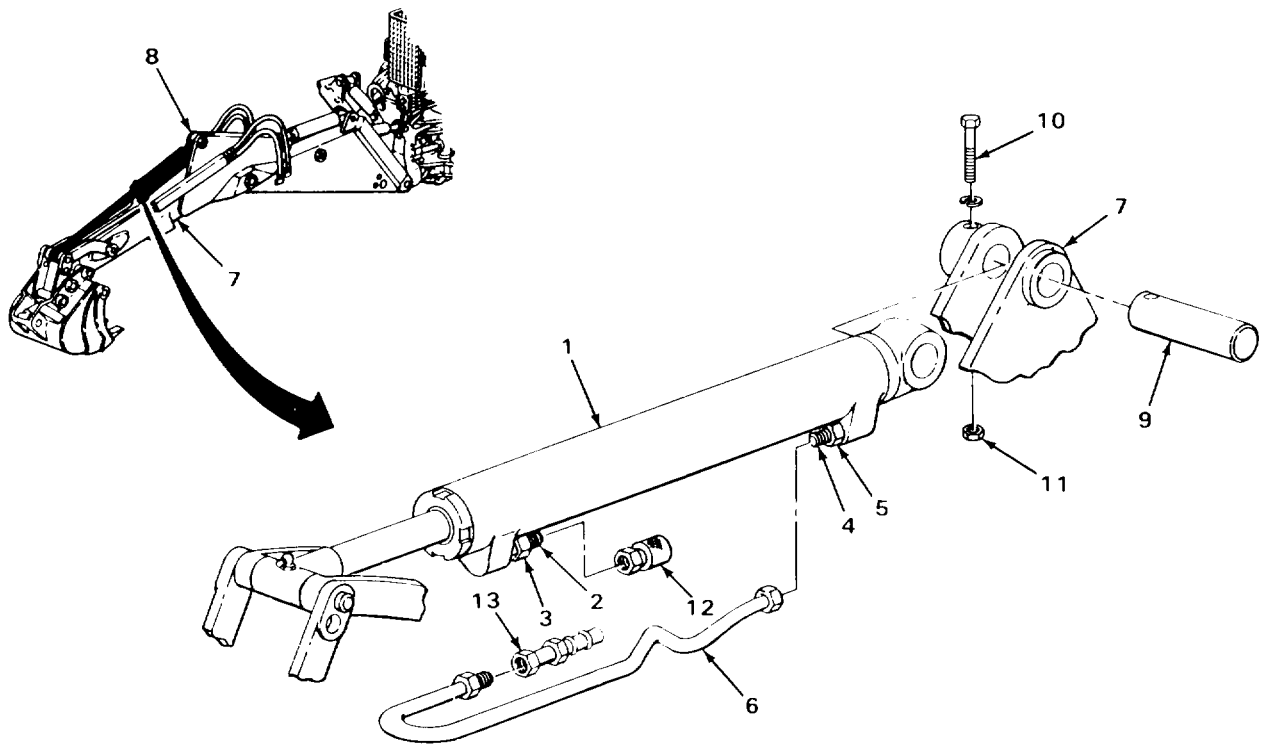

BOOM-TO-BUCKET CYLINDER OIL LINES (SERIAL NUMBERS 319995 THRU 342573 ONLY) - CONTINUED

LOCATION	ITEM	ACTION	REMARKS
INSTALLATION			
43.	Boom (1)	Tube (2 or 3)	a. Take off tag. b. Place in same relative position noted during removal.
44.	Dipperstick (4)	Hose (5 or 6)	a. Take off tag. b. Place in same relative position noted during removal.
45.	Tube (2 or 3)	Hose (5 or 6)	Screw in and tighten using 7/8-inch and 1-inch open-end wrenches.
46.	Boom (1) and two tubes (2 and 3)	Clamp (7) and two spacers (8 and 9)	Place in position.
47.	Boom (1), two spacers (8 and 9) and clamp (7)	Screw (10) and new lockwasher (11)	Screw in and tighten using 9/16-inch, 3/8-inch drive socket and ratchet handle.

NOTE

If installing boom-to-rod end bucket cylinder oil line, skip steps 48 and 49.

48.	Hose (5)	Quick coupler (12)	Screw on and tighten using 7/8-inch and 1 1/16-inch open-end wrenches.
49.	Male nipple (13)	Quick coupler (12) with assembled hose (5)	Snap on.

NOTE

If installing boom-to-head end bucket cylinder oil line, skip steps 50 and 51.

50.	Hose (6)	Male nipple (14)	Screw on and tighten using 7/8-inch and 1 1/16-inch open-end wrenches.
51.	Quick coupler (15)	Male nipple (14) with assembled hose (6)	Snap in.

BOOM-TO-BUCKET CYLINDER OIL LINES (SERIAL NUMBERS 319995 THRU 342573 ONLY) - CONTINUED

LOCATION	ITEM	ACTION REMARKS
52. Bucket cylinder (16), tube (17), and quick coupler (15)	Two spacers (18) during removal.	Place in same relative position noted
53. Bucket cylinder (16), two spacers (18) and tube (17)	Clamp (19)	a. Place in position. b. Using 1/4-inch flat-tip screwdriver, tighten.

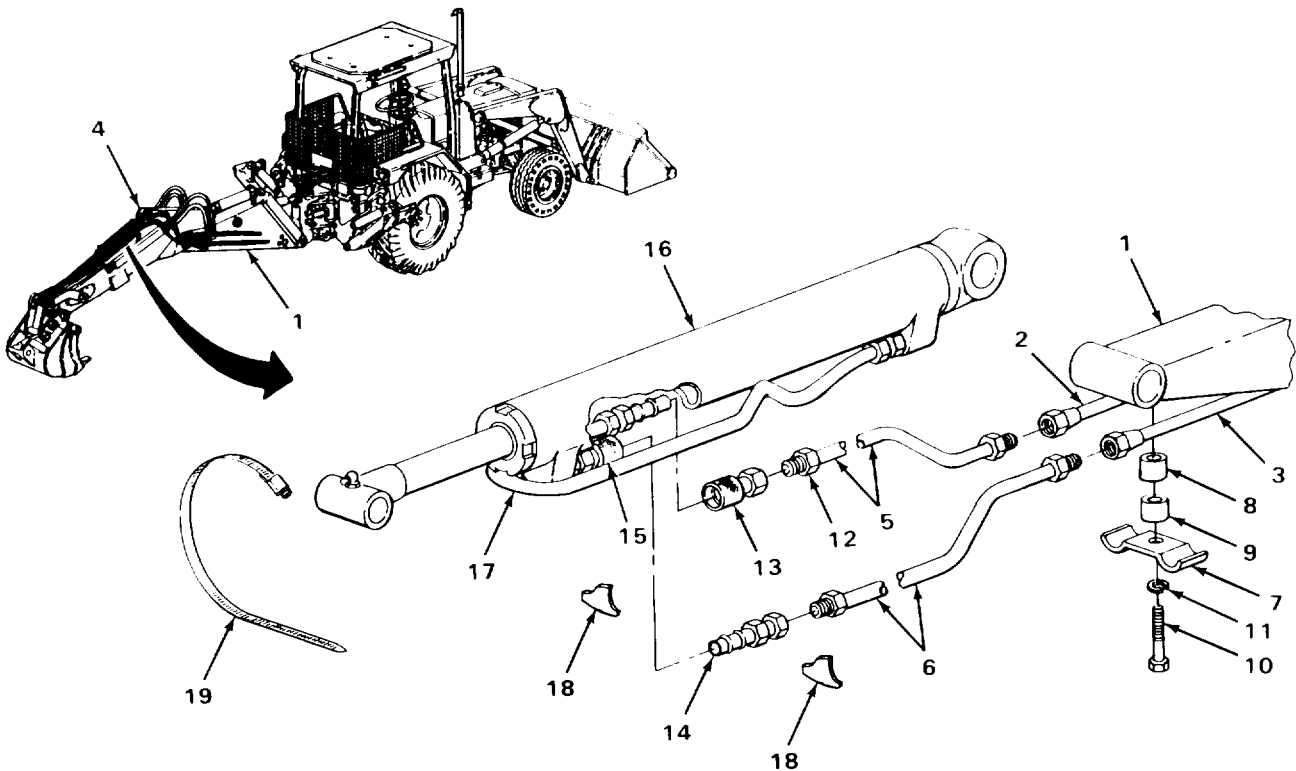

BOOM-TO-BUCKET CYLINDER OIL LINES (SERIAL NUMBERS 319995 THRU 342573 ONLY) - CONTINUED

LOCATION	ITEM	ACTION REMARKS
54.	Tube (1 or 2)	Hose (3 or 4) a. Take off tag. b. Uncap. c. Screw in and tighten using 7/8-inch and 1-inch open-end wrenches.
55.	Boom (5) and four tubes (1, 2, 6, and 7)	Three clamps (8 thru 10) and spacer (11) Place in position.
56.	Boom (5), three clamps (8 thru 10) and spacer (11)	Screw (12) Screw in and tighten using 9/16-inch, 3/8-inch drive socket and ratchet handle.
57.	Loader backhoe	Transmission Check fluid level and add proper amount and grade (TM 5-2420-222-10).
58.		Engine Start and run at high idle (TM 5-2420-222-10).
59.	Boom-to-bucket cylinder oil lines	a. Operate backhoe bucket (TM 5-2420-222-10) and check for leaks. b. If leaking at any connection, tighten using 7/8-inch, two 1-inch, and 1 1/16-inch open-end wrenches. c. If leaking does not stop, shut down engine (TM 5-2420-222-10) and replace leaking connection packing, fitting, hose, or tube as outlined in this task. d. If found leaking, repeat steps 57 thru 59.
60.		Engine If still running, shut down (TM 5-2420-222-10).

BOOM-TO-BUCKET CYLINDER OIL LINES (SERIAL NUMBERS 319995 THRU 342573 ONLY) - CONTINUED

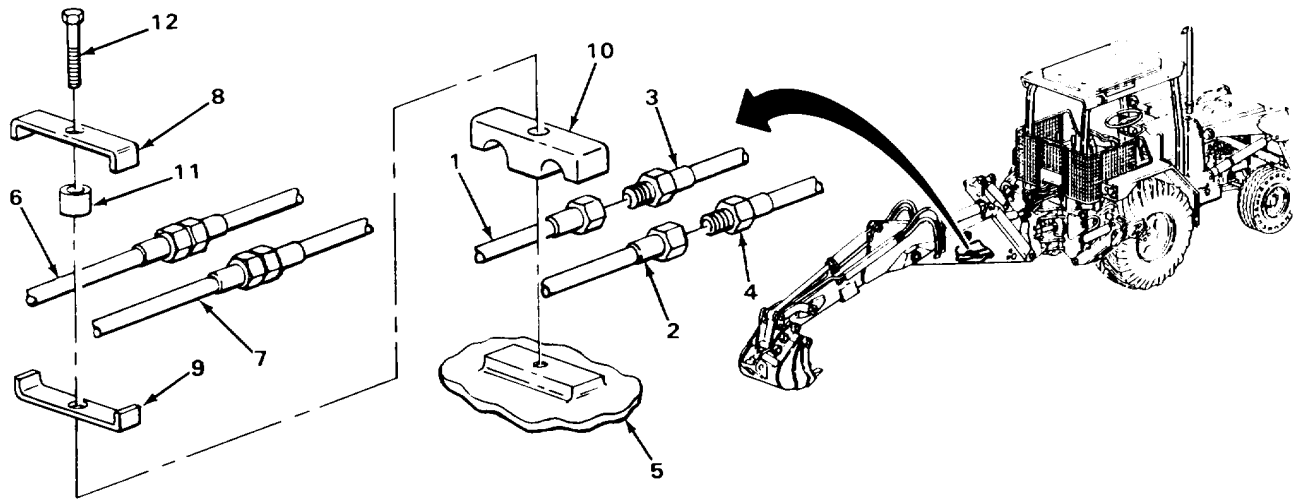

TASK ENDS HERE

TA243510

2-1621

BACKHOE CONTROL VALVE-TO-BACKHOE STABILIZER CYLINDER OIL LINES

This task covers:

- a. Removal (page 2-1623)
- b. Cleaning (page 2-1628)
- c. Inspection/Replacement (page 2-1630)
- d. Installation (page 2-1630)

INITIAL SETUP:

Tools

- Handle, ratchet, 3/8-inch drive
- Handle, ratchet, 1/2-inch drive
- Knife, pocket
- Pan, drain
- Screwdriver, flat-tip, 1/4-inch
- Screwdriver, 3/8-inch drive, 9/16-inch
- Screwdriver, 1/2-inch drive, 11/4-inch
- Wrench, open-end, 9/16-inch
- Wrench, open-end, 11/16-inch
- Wrench, open-end, 3/4-inch
- Wrench, open-end, 7/8-inch
- Wrench, open-end, 1-inch
(two required)
- Wrench, open-end, 11/16-inch
- Wrench, open-end, 1 1/8-inch
- Wrench, open-end, 1 1/4-inch
- Wrench, open-end, 1 3/8-inch

Materials/Parts

- Detergent, GP (item 7, Appendix C)
- Lockwasher, clamp screw (two required)

Materials/Parts - Continued

- Packing, adapter
- Packing, adapter
- Packing, union adapter (two required)
- Packing, union adapter (two required)
- Rags, wiping (item 21, Appendix C)
- Solvent, dry-cleaning (item 28, Appendix C)
- Tags, marking (item 30, Appendix C)

Personnel Required

One

Equipment Condition

1. Backhoe valve box cover removed (page 2-1157)
2. Hydraulic system pressure released (page 2-1191)

LOCATION	ITEM	ACTION	REMARKS
----------	------	--------	---------

NOTE

Right and left side backhoe control valve-to-backhoe stabilizer cylinder oil lines are maintained the same way except as noted. Right side oil lines are shown. Repeat procedures as needed for left side oil lines.

BACKHOE CONTROL VALVE-TO-BACKHOE STABILIZER CYLINDER OIL LINES - CONTINUED

LOCATION	ITEM	ACTION	REMARKS
----------	------	--------	---------

REMOVAL

NOTE

If only removing backhoe control valve-to-head end stabilizer cylinder oil line, skip steps 1 thru 5.

WARNING

Do not attempt to disconnect hydraulic lines and fittings while engine is running or before hydraulic system pressure has been released. When engine is running, hydraulic system is under pressure. Hydraulic system pressure should be 0 psi (0 kPa) before lines are disconnected. A line or fitting disconnected under pressure will blow off with a lot of force and could cause serious injury to personnel.

Be careful when draining hot fluids. Wear gloves to protect your hands from hot parts and fluids or severe burns could result.

- | | | | |
|----|-------------|----------|---|
| 1. | Adapter (1) | Hose (2) | a. Place drain pan underneath.
b. Using 11/16-inch and 7/8-inch open-end wrenches, unscrew and take out. |
|----|-------------|----------|---|

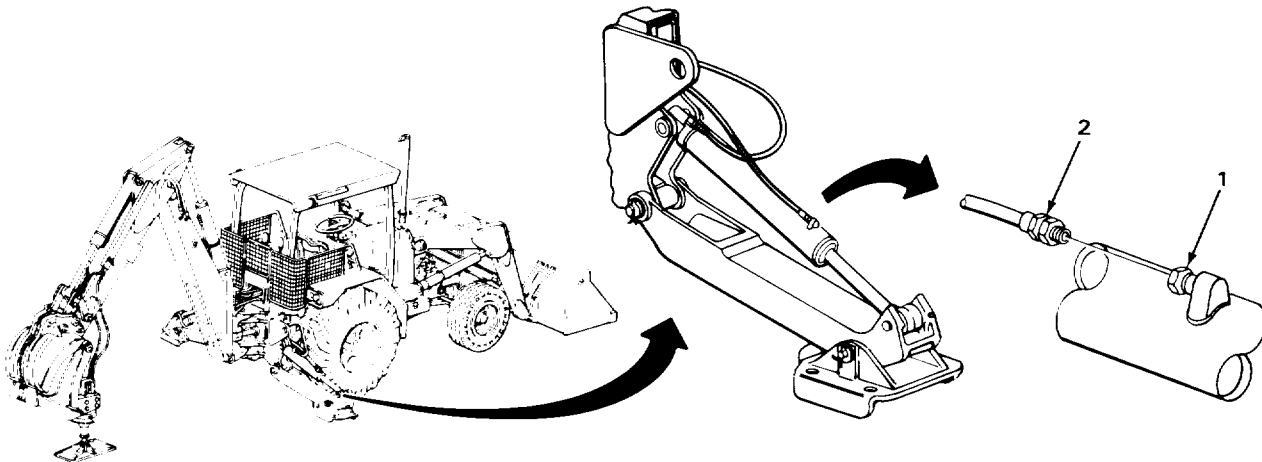

BACKHOE CONTROL VALVE-TO-BACKHOE STABILIZER CYLINDER OIL LINES - CONTINUED

LOCATION	ITEM	ACTION	REMARKS
REMOVAL - CONTINUED			
2.	Stabilizer cylinder (1)	Adapter (2) with assembled packing (3)	a. Using 7/8-inch open-end wrench, unscrew and take out. b. Plug cylinder (1) (page 2-137).
3.	Adapter (2)	Packing (3)	a. Using pocket knife, take off. b. Get rid of.
4.	Clamp (4) and main frame (5)	Screw (6), lock-washer (7), washer (8) and nut (9)	a. Using 9/16-inch, 3/8-inch drive socket and ratchet handle, and 9/16-inch open-end wrench, unscrew and take apart. b. Get rid of lockwasher (7).
5.	Hose (10)	Clamp (4)	a. Note position for proper placement during installation. b. Using 1/4-inch flat-tip screwdriver, spread and take off.

NOTE

If only removing backhoe control valve-to-rod end stabilizer cylinder oil line, skip steps 6 thru 10.

WARNING

Do not attempt to disconnect hydraulic lines and fittings while engine is running or before hydraulic system pressure has been released. When engine is running, hydraulic system is under pressure. Hydraulic system pressure should be 0 psi (0 kPa) before lines are disconnected. A line or fitting disconnected under pressure will blow off with a lot of force and could cause serious injury to personnel.

Be careful when draining hot fluids. Wear gloves to protect your hands from hot parts and fluids or severe burns could result.

6.	Adapter (11)	Hose (12)	a. Place drain pan underneath. b. Using 11/16-inch and 7/8-inch open-end wrenches, unscrew and take out.
7.	Stabilizer cylinder (1)	Adapter (11) with assembled packing (13)	a. Using 7/8-inch open-end wrench, unscrew and take out. b. Plug cylinder (1) (page 2-137).
8.	Adapter (11)	Packing (13)	a. Using pocket knife, take off. b. Get rid of. c. Plug cylinder (1) (page 2-137).

BACKHOE CONTROL VALVE-TO-BACKHOE STABILIZER CYLINDER OIL LINES - CONTINUED

LOCATION	ITEM	ACTION	REMARKS
9.	Clamp (14) and main frame (5)	Screw (15), lock-washer (16), and washer (17)	<ul style="list-style-type: none"> a. Using 9/16-inch, 3/8-inch drive socket and ratchet handle, unscrew and take out. b. Get rid of lockwasher (16).
10.	Hose (12)	Clamp (14)	<ul style="list-style-type: none"> a. Note position for proper placement during installation. b. Using 1/4-inch flat-tip screwdriver, spread and take off.

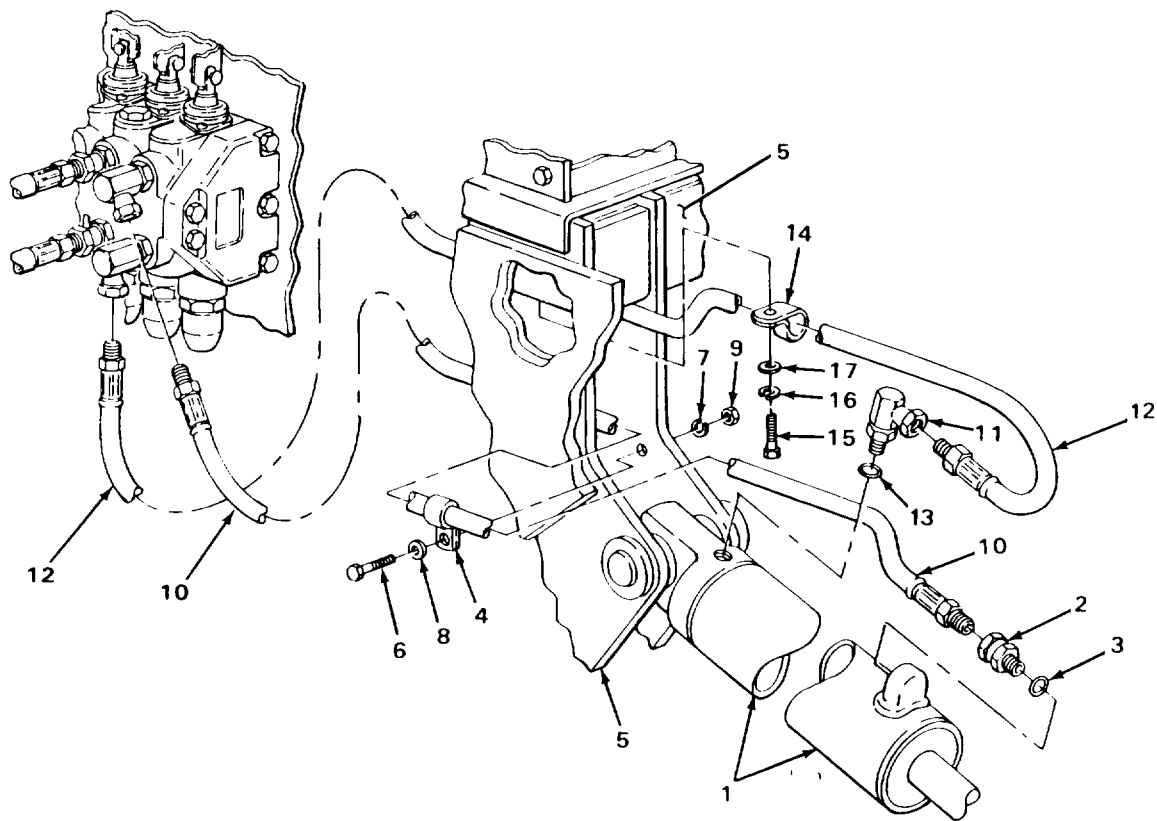

2-1625

TA243512

BACKHOE CONTROL VALVE-TO-BACKHOE STABILIZER CYLINDER OIL LINES - CONTINUED

LOCATION	ITEM	ACTION	REMARKS
REMOVAL - CONTINUED			
NOTE			
If removing right side backhoe control valve-to-backhoe stabilizer cylinder oil lines, skip steps 11 thru 18.			
11.	Special adapter (1)	Hose (2)	a. Place drain pan underneath. b. Using 1 1/8-inch and 1 1/4-inch open-end wrenches, unscrew and take out. c. Cap (page 2-137). d. Plug adapter (1) (page 2-137). e. Tag (page 2-137).
12.	Union adapter (3)	Special adapter (1)	a. Using 1 1/4-inch and 1 3/8-inch open-end wrenches, unscrew and take out. b. Cap (page 2-137). c. Plug adapter (3) (page 2-137). d. Tag (page 2-137).
13.	Backhoe control valve (4)	Union adapter (3) with assembled packing (5)	Using 1 1/4-inch, 1/2-inch drive socket and ratchet handle, unscrew and take out.
14.	Union adapter (3)	Packing (5)	a. Using pocket knife take off. b. Get rid of.
NOTE			
If only removing left side backhoe control valve-to-rod end stabilizer cylinder oil line, skip steps 15 thru 18.			
15.	Special adapter (6)	Hose (7)	a. Using 1 1/16-inch and 1 1/4-inch open-end wrenches, unscrew and take out. b. Cap (page 2-137). c. Tag (page 2-137).
16.	Union adapter (8)	Special adapter (6)	a. Using 1 1/4-inch and 1 3/8-inch open-end wrenches, unscrew and take out. b. Tag (page 2-137).
17.	Backhoe control valve (4)	Union adapter (8) with assembled packing (9)	Using 1 1/4-inch, 1/2-inch drive socket and ratchet handle, unscrew and take out.

BACKHOE CONTROL VALVE-TO-BACKHOE STABILIZER CYLINDER OIL LINES - CONTINUED

LOCATION	ITEM	ACTION	REMARKS
18. Union adapter (8)	Packing (9)	a. Using pocket knife, take off. b. Get rid of.	
19. Union adapter (10)	Hose (11)	a. Place drain pan underneath. b. Using 11/16-inch and 7/8-inch open-end wrenches, take out.	

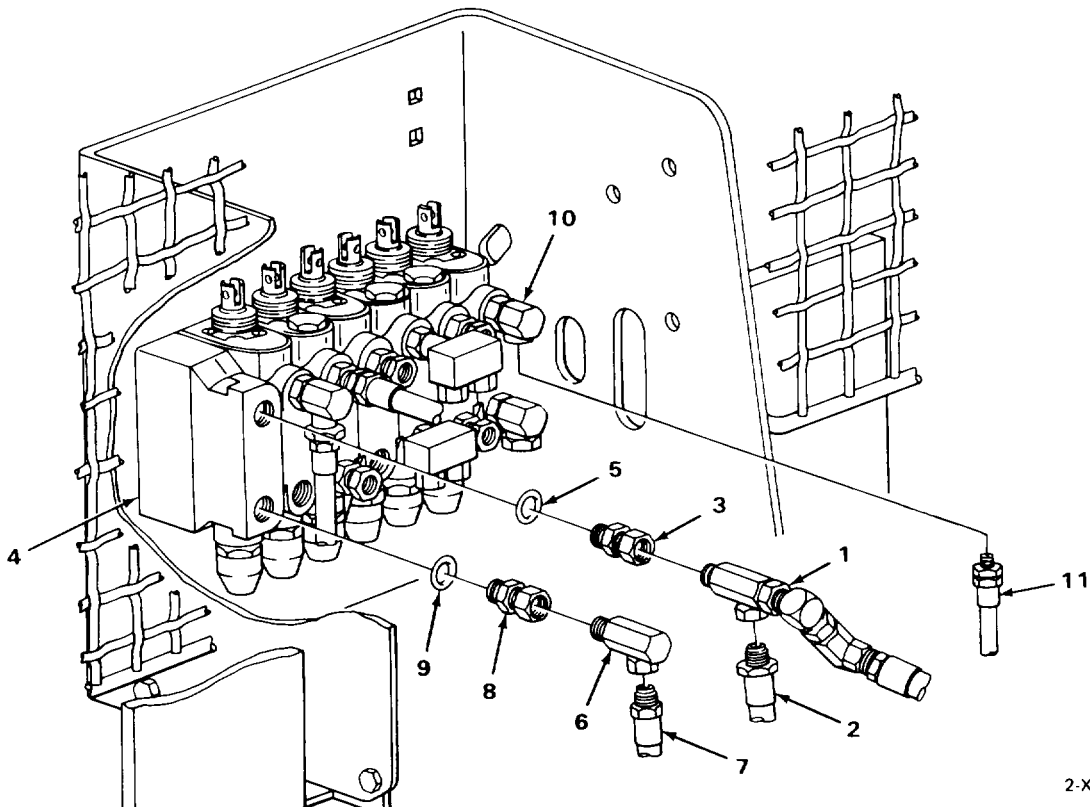

2-1627

2-XX-204.1

TA243513

BACKHOE CONTROL VALVE-TO-BACKHOE STABILIZER CYLINDER OIL LINES - CONTINUED

LOCATION	ITEM	ACTION	REMARKS
REMOVAL - CONTINUED			
20.	Backhoe control valve (1) and union adapter (2)	Nut (3)	Using two 1-inch open-end wrenches, loosen.
21.	Backhoe control valve (1)	Union adapter (2) with assembled parts	a. Note relative position for proper placement during installation. b. Using 1-inch open-end wrench, unscrew and take out. c. Cap control valve (1) (page 2-137).
22.	Union adapter (2)	Packing (4)	a. Using pocket knife, take off. b. Get rid of.

NOTE

If only removing backhoe control valve-to-rod end stabilizer cylinder oil lines, skip steps 13 thru 16.

23.	Union adapter (5)	Hose (6)	a. Place drain pan underneath. b. Using 11/16-inch and 7/8-inch open-end wrenches, unscrew and take out. c. Get rid of drained fluid.
24.	Backhoe control valve (1) and union adapter (5)	Nut (7)	Using two 1-inch open-end wrenches, loosen.
25.	Backhoe control valve (1)	Union adapter (5) with assembled parts	a. Note relative position for proper placement during installation. b. Using 1-inch open-end wrench, unscrew and take out. c. Cap control valve (1) (page 2-137).
26.	Union adapter (5)	Packing (8)	a. Using pocket knife, take off. b. Get rid of.

CLEANING
NOTE

For more information on how to clean parts, go to General Maintenance Instructions (page 2-137).

BACKHOE CONTROL VALVE-TO-BACKHOE STABILIZER CYLINDER OIL LINES - CONTINUED

LOCATION	ITEM	ACTION	REMARKS
----------	------	--------	---------

- | | | | |
|-----|-----------------|---|--|
| 27. | Hoses (6 and 9) | a. Using clean rags dampened with solution of detergent and water, wipe clean.
b. Rinse with clean water.
c. Using clean, dry rags, wipe dry. | |
|-----|-----------------|---|--|

WARNING

Dry-cleaning solvent P-D-680 is toxic and flammable. Wear protective goggles and gloves and use only in a well ventilated area. Avoid contact with skin, eyes, and clothes and don't breathe vapors. Do not use near open flame or excessive heat. The flashpoint is 100°F to 138°F (38° to 59°C). If you become dizzy while using cleaning solvent, get fresh air immediately and get medical aid. If contact with eyes is made, wash your eyes with water and get medical aid immediately.

- | | | | |
|-----|-----------------|--|--|
| 28. | All metal parts | a. Clean in dry-cleaning solvent.
b. Using clean, dry rags, wipe dry. | |
|-----|-----------------|--|--|

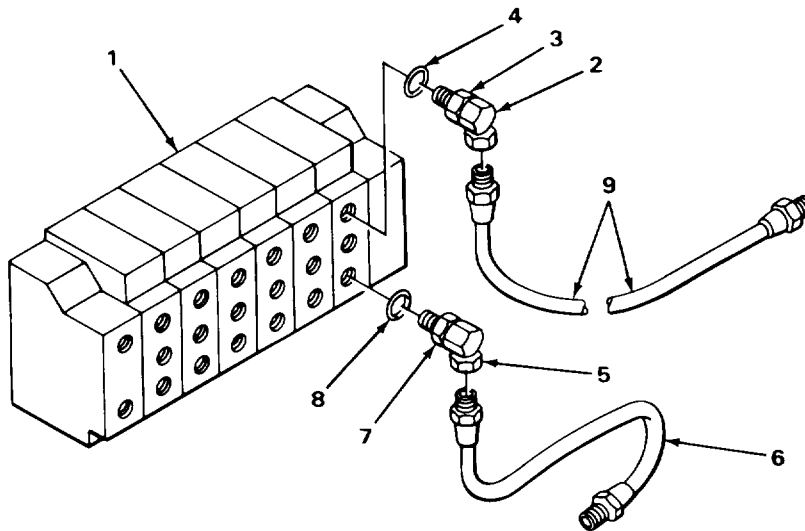

BACKHOE CONTROL VALVE-TO-BACKHOE STABILIZER CYLINDER OIL LINES - CONTINUED

LOCATION	ITEM	ACTION	REMARKS
----------	------	--------	---------

INSPECTION/REPLACEMENT**NOTE**

For more information on how to inspect parts, go to **General Maintenance Instructions (page 2-137)**.

Replace defective parts as needed.

29.	Hoses (1 and 2)		Look for cuts, cracks, and breaks.
30.	All metal parts		Look for cracks, breaks, and abnormal bends.
31.	All threaded parts		Look for damaged threads.

INSTALLATION**NOTE**

If installing backhoe control valve to rod end stabilizer or cylinder oil lines, skip step 32 thru 36.

32.	Union adapter (3)	Nut (4)	Screw on all the way.
33.		New packing (5)	Place in position.
34.	Backhoe control valve (6)	Union adapter (3) with assembled parts	a. Uncap control valve (6). b. Screw in and tighten to same relative position as noted during removal using 1-inch open-end wrench.
35.	Backhoe control (6) and union adapter (3)	Nut (4)	Using two 1-inch open-end wrenches, tighten until snug against control valve (6).
36.	Union adapter (3)	Hose (2)	Screw in and tighten using 11/16-inch and 7/8-inch open-end wrenches.
37.	Union adapter (7)	Nut (8)	Screw on all the way.
38.		New packing (9)	Place in position.
39.	Backhoe control valve (6)	Union adapter (7) with assembled parts	a. Uncap control valve (6). b. Screw in and tighten to same relative position as noted during removal using 1-inch open-end wrench.

BACKHOE CONTROL VALVE-TO-BACKHOE STABILIZER CYLINDER OIL LINES - CONTINUED

LOCATION	ITEM	ACTION	REMARKS
40. Backhoe control (6) and union adapter (7)	Nut (8)	Using two 1-inch open-end wrenches, tighten until snug against control valve (6).	
41. Union adapter (7)	Hose (1)	Screw in and tighten using 11/16-inch and 7/8-inch open-end wrenches.	

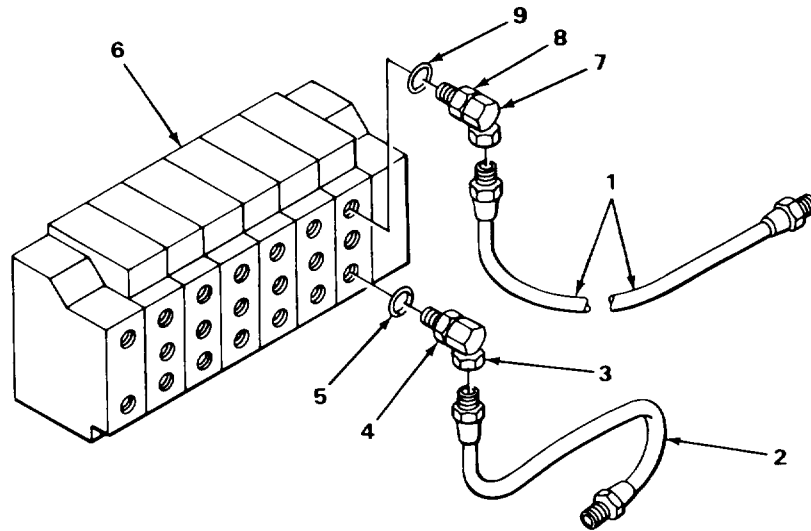

2-1631

TA243515

BACKHOE CONTROL VALVE-TO-BACKHOE STABILIZER CYLINDER OIL LINES - CONTINUED

LOCATION	ITEM	ACTION	REMARKS
INSTALLATION - CONTINUED			
NOTE			
If only right side backhoe control valve-to-backhoe stabilizer cylinder oil lines were removed, skip steps 42 thru 49.			
If only left side backhoe control valve-to-rod end stabilizer cylinder oil lines were removed, skip steps 42 thru 45.			
42.	Union adapter (1)	New packing (2)	Place in position.
43.	Backhoe control valve (3)	Union adapter (1) with assembled packing (2)	Screw in and tighten using 1 1/4-inch, 1/2-inch drive socket and ratchet handle.
44.	Union adapter (1)	Special adapter (4)	a. Take off tag. b. Screw on and tighten using 1 1/4-inch and 1 3/8-inch open-end wrenches.
45.	Special adapter (4)	Hose (5)	a. Take off tag. b. Take off cap. c. Screw in and tighten using 1 1/16-inch and 1 1/4-inch open-end wrenches.
46.	Union adapter (6)	New packing (7)	Place in position.
47.	Backhoe control valve (3)	Union adapter (6) with assembled packing (7)	Screw in and tighten using 1 1/4-inch, 1/2-inch drive socket and ratchet handle.
48.	Union adapter (6)	Special adapter (8)	a. Take off tag. b. Unplug adapter (6). c. Take off cap. d. Screw in and tighten using 1 1/4-inch and 1 3/8-inch open-end wrenches.
49.	Special adapter (8)	Hose (9)	a. Take off tag. b. Unplug adapter (8). c. Take off cap. d. Screw in and tighten using 1 1/8-inch and 1 1/4-inch open-end wrenches.

BACKHOE CONTROL VALVE-TO-BACKHOE STABILIZER CYLINDER OIL LINES - CONTINUED

LOCATION	ITEM	ACTION	REMARKS
----------	------	--------	---------

NOTE

If only installing backhoe control valve-to-head end stabilizer cylinder oil lines, skip steps 50 thru 54.

50. Hose (10)	Clamp (11)	Place in position.	
51. Clamp (11) and main frame (12)	Screw (13), new lockwasher (14), washer (15), and nut (16)	Screw together and tighten using 9/16-inch open-end wrench, and 9/16-inch, 3/8-inch drive socket and ratchet handle.	
52. Adapter (17)	New packing (18)	Place in position.	
53. Stabilizer cylinder (19)	Adapter (17) with assembled packing (18)	a. Unplug cylinder(10). b. Screw in and tighten using 7/8-inch open-end wrench.	
54. Adapter (17)	Hose (10)	Screw in and tighten using 11/16-inch and 7/8-inch open-end wrenches.	

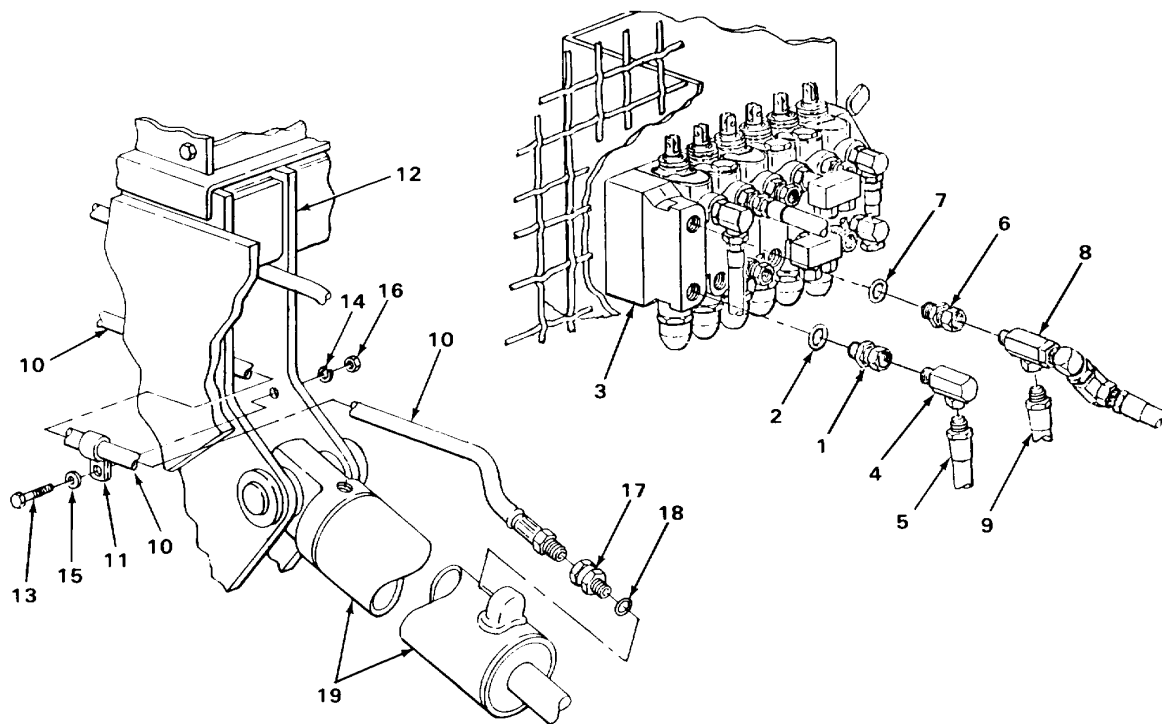

TA243516

BACKHOE CONTROL VALVE-TO-BACKHOE STABILIZER CYLINDER OIL LINES - CONTINUED

LOCATION	ITEM	ACTION	REMARKS
INSTALLATION - CONTINUED			
NOTE			
If only installing backhoe control valve-to-rod end stabilizer cylinder oil lines, skip steps 55 and 59.			
55.	Hose (1)	Clamp (2)	Place in position as noted during removal.
56.	Clamp (2) and main frame (3)	Screw (4), new lock-washer (5), and washer (6)	Screw and tighten using 9/16-inch, 3/8-inch drive socket and ratchet handle.
57.	Adapter (7)	New packing (8)	Place in position.
58.	Stabilizer cylinder (9)	Adapter (7) with assembled packing (8)	a. Unplug cylinder (10). b. Screw in and tighten using 7/8-inch open-end wrench.
59.	Adapter (7)	Hose (1)	Screw in and tighten using 11/16-inch and 7/8-inch open-end wrenches.
60.	Handle mount (10)	Control lever (11)	Screw into position noted during removal.
61.	Handle mount (10) and control lever (11)	Nuts (12)	Using 3/4-inch open-end wrench, tighten until seated against handle mount (18).
62.	Loader backhoe	Transmission	Check fluid level and add proper amount and grade (TM 5-2420-222-10).
63.		Engine	Start and run at high idle (TM 5-2420-222-10).
64.		Backhoe control valve-to-stabilizer cylinder oil lines	a. Operate backhoe controls (TM 5-2420-222-10) and check for leaks. b. If leaking at any connection, tighten using 7/8-inch, 11/16-inch, and two 1-inch open-end wrenches. c. If leaking does not stop, shut down engine (TM 5-2420-222-10) and replace leaking connection packing, fitting, or hose as outlined in this task. d. If found leaking, repeat steps 62 thru 64.

BACKHOE CONTROL VALVE-TO-BACKHOE STABILIZER CYLINDER OIL LINES - CONTINUED

LOCATION	ITEM	ACTION	REMARKS
65.	Engine	If still running, shut down (TM 5-2420-222-10).	
66. Handle mount (10) and control lever (11)	Nut (12)	Using 3/4-inch open-end wrench, loosen.	
67. Handle mount (10)	Control lever (11)	Noting position, unscrew and take out.	

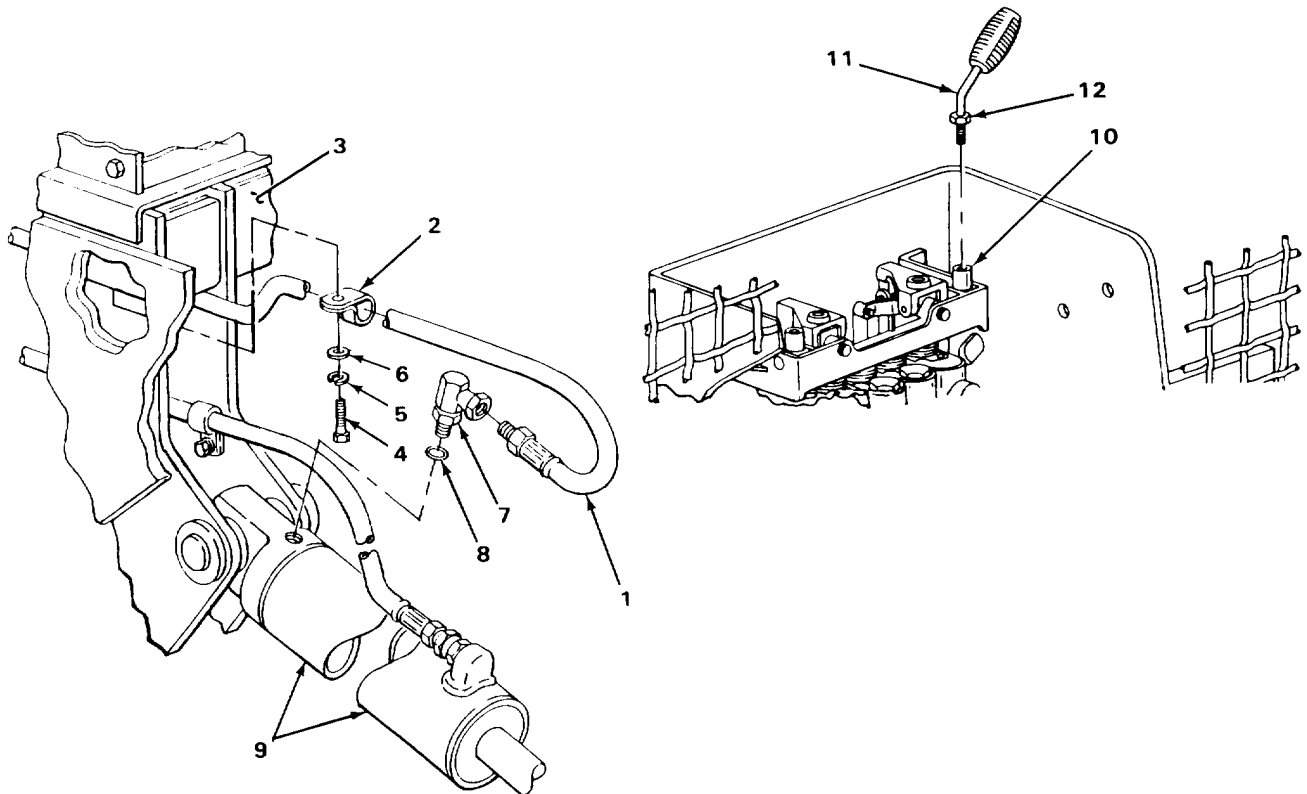

NOTE

FOLLOW-ON MAINTENANCE: Install backhoe valve box cover (page 2-1157).

TASK ENDS HERE

TA243517

BACKHOE CONTROL VALVE-TO-BACKHOE SWING CYLINDER OIL LINES

This task covers:

- | | |
|---|--|
| <ul style="list-style-type: none"> a. Removal (page 2-1637) b. Cleaning (page 2-1640) | <ul style="list-style-type: none"> c. Inspection/Replacement (page 2-1641) d. Installation (page 2-1642) |
|---|--|

INITIAL SETUP

Tools

- Handle, ratchet, 1/2-inch drive
- Knife, pocket
- Pan, drain
- Socket, deep, 1/2-inch drive, 1-inch
- Wrench, open-end, 5/8-inch
- Wrench, open-end, 11/16-inch
- Wrench, open-end, 3/4-inch
- Wrench, open-end, 7/8-inch
(two required)
- Wrench, open-end, 15/16-inch
- Wrench, open-end, 1-inch
(two required)

Materials/Parts (page 2-1157)

- Detergent, GP (item 7, Appendix C) (page 2-1191)
- Packing, adapter (four required)
- Packing, special union adapter
(two required)

Materials/Parts - Continued

- Packing, union adapter
- Packing, union adapter
- Rags, wiping (item 21, Appendix C)
- Solvent, drycleaning (item 28, Appendix C)
- Tags, marking (item 30, Appendix C)

Personnel Required

One

Equipment Condition

1. Backhoe valve box cover removed
2. Hydraulic system pressure released

LOCATION	ITEM	ACTION	REMARKS
----------	------	--------	---------

NOTE

Right and left side backhoe control valve-to-backhoe swing cylinder oil lines are maintained the same way except that wrench sizes for rod end and head end hoses are reversed. Both lines for right side swing cylinder are shown. Repeat procedures as needed for left cylinder oil lines.

BACKHOE CONTROL VALVE-TO-BACKHOE STABILIZER CYLINDER OIL LINES - CONTINUED

LOCATION	ITEM	ACTION	REMARKS
----------	------	--------	---------

REMOVAL

WARNING

Do not attempt to disconnect hydraulic lines and fittings while engine is running or before hydraulic system pressure has been released. When engine is running, hydraulic system is under pressure. Hydraulic system pressure should be 0 psi (0 kPa) before lines are disconnected. A line or fitting disconnected under pressure will blow off with a lot of force and could cause serious injury to personnel.

Be careful when draining hot fluids. Wear gloves to protect your hands from hot parts and fluids or severe burns could result.

- | | | |
|---|--|--|
| 1. Union adapter (1) | Hose (2) | <ul style="list-style-type: none"> a. Place drain pan underneath. b. Using 11/16-inch and 7/8-inch open-end wrenches for right side, or 7/8-inch and 1-inch open-end wrenches for left side, unscrew and take out. |
| 2. Union adapter (1) and swing cylinder (3) | Nut (4) | Using two 7/8-inch open-end wrenches, loosen. |
| 3. Swing cylinder (3) | Union adapter (1) with assembled parts | <ul style="list-style-type: none"> a. Note relative position for proper placement during installation. b. Using 7/8-inch open-end wrench, unscrew and take out. c. Plug cylinder (3) (page 2-137). |

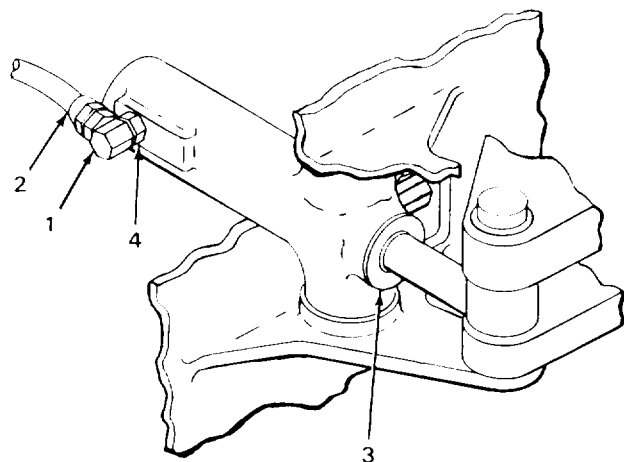
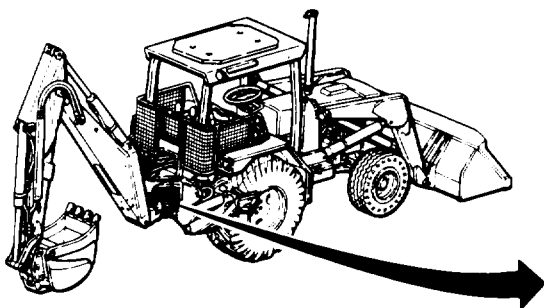

BACKHOE CONTROL VALVE-TO-BACKHOE STABILIZER CYLINDER OIL LINES - CONTINUED

LOCATION	ITEM	ACTION REMARKS
REMOVAL - CONTINUED		
4. Union adapter (1)	Packing (2)	a. Using pocket knife, take off. b. Get rid of.
5. Special union adapter (3)	Two hoses (4 and 5)	a. Place drain pan underneath. b. Using 11/16-inch and 7/8-inch open-end wrenches, unscrew and take out. c. Tag (page 2-137). d. Cap hose (5) (page 2-137).
6. Four adapters (6)	Four hoses (7)	a. Using 7/8-inch and 1-inch open-end wrenches, unscrew and take out. b. Cap (page 2-137). c. Tag (page 2-137).
7. Backhoe control valve (8)	Four adapters (6) with assembled packings (9)	a. Using 1-inch, 1/2-inch drive deep socket and ratchet handle, unscrew and take out. b. Plug valve (8).
8. Four adapters (6)	Four packings (9)	a. Using pocket knife, take off. b. Get rid of.
9. Backhoe control valve (8) and special union adapter (3)	Nut (10)	Using two 1-inch open-end wrenches, loosen.
10. Backhoe control valve (8)	Special union adapter (3) with assembled parts	a. Note relative position for proper placement during installation. b. Using 1-inch open-end wrench, unscrew and take out. c. Plug control valve (8).
11. Special union adapter (3)	Packing (11)	a. Using pocket knife, take off. b. Get rid of.
12. Union adapter (12)	Hose (13)	a. Place drain pan underneath. b. Using 7/8-inch and 1-inch open-end wrenches for right side, or 7/8-inch and 11/16-inch open-end wrenches for left side, unscrew and take out. c. Tag (page 2-137).

BACKHOE CONTROL VALVE-TO-BACKHOE STABILIZER CYLINDER OIL LINES - CONTINUED

LOCATION	ITEM	ACTION	REMARKS
13. Swing cylinder (14) and union adapter (12)	Nut (15)	Using 5/8-inch and 11/16-inch open-end wrenches, loosen.	
14. Swing cylinder (14)	Union adapter (12) with assembled Parts	a. Note relative position for proper placement during installation. b. Using 5/8-inch open-end wrench, unscrew and take out. c. Plug cylinder(14).	
15. Union adapter (12)	Packing (16)	a. Using pocket knife, take off. b. Get rid of.	

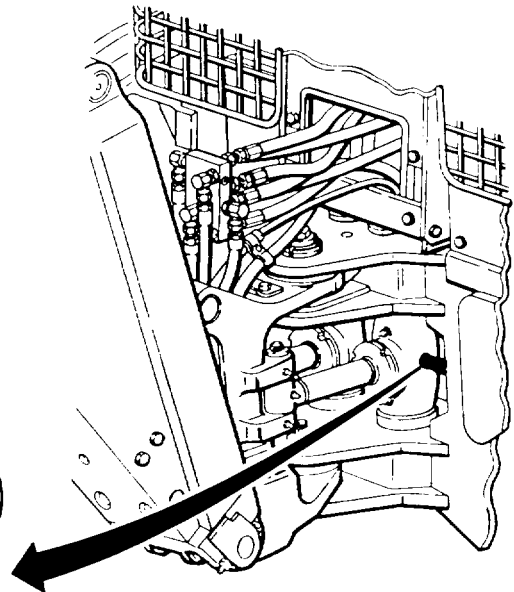
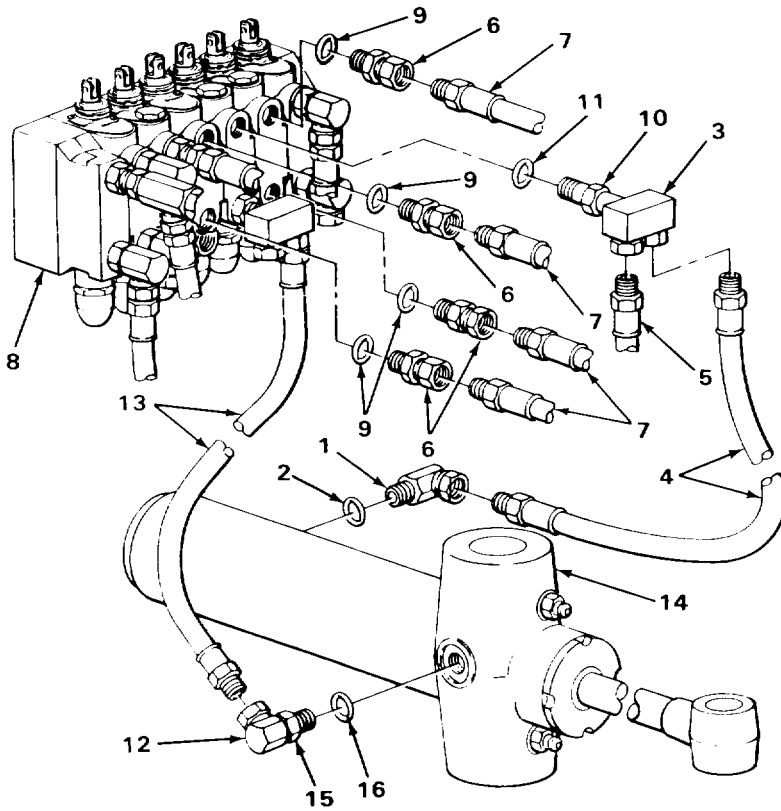

BACKHOE CONTROL VALVE-TO-BACKHOE STABILIZER CYLINDER OIL LINES - CONTINUED

LOCATION	ITEM	ACTION REMARKS
REMOVAL - CONTINUED		
16. Special union adapter (1)	Two hoses (2 and 3)	<ul style="list-style-type: none"> a. Place drain pan underneath. b. Using 3/4-inch and 7/8-inch open-end wrenches, unscrew and take out. c. Tag (page 2-137). d. Cap hose (3) (page 2-137). e. Get rid of drained fluid (page 2-137).
17. Backhoe control valve (4) and special union adapter (1)		Using two 1-inch open-end wrenches, loosen.
18. Backhoe control valve (4)	Special union adapter (1) with assembled parts	<ul style="list-style-type: none"> a. Note relative position for proper placement during installation. b. Using 1-inch open-end wrench, unscrew and take out. c. Plug valve (4) (page 2-137).
19. Special union adapter (1)	Packing (6)	<ul style="list-style-type: none"> a. Using pocket knife, take off. b. Get rid of.

CLEANING**NOTE**

For more information on how to clean parts, go to General Maintenance Instructions (page 2-137).

20.	Two hoses (2 and 7)	<ul style="list-style-type: none"> a. Using clean rags dampened with solution of detergent and water, wipe clean. b. Using clean rags dampened with clean water, rinse. c. Using clean, dry rags, wipe dry.
-----	---------------------	--

WARNING

Drycleaning solvent P-D-680 is toxic and flammable. Wear protective goggles and gloves and use only in a well ventilated area. Avoid contact with skin, eyes, and clothes and don't breathe vapors. Do not use near open flame or excessive heat. The flashpoint is 100° to 138° (38° to 59°C). If you become dizzy while using cleaning solvent, get fresh air immediately and get medical aid. If contact with eyes is made, wash your eyes with water and get medical aid immediately.

21.	All metal parts	<ul style="list-style-type: none"> a. Clean in drycleaning solvent. b. Using clean, dry rags, wipe dry.
-----	-----------------	---

BACKHOE CONTROL VALVE-TO-BACKHOE STABILIZER CYLINDER OIL LINES - CONTINUED

LOCATION	ITEM	ACTION	REMARKS
----------	------	--------	---------

INSPECTION/REPLACEMENT

NOTE

For more information on how to inspect parts, go to General Maintenance Instructions (page 2-137).

Replace defective parts as needed.

- | | | |
|-----|------------------------|------------------------------------|
| 22. | Two hoses
(2 and 7) | Look for cuts, cracks, and breaks. |
| 23. | All metal parts | Look for cracks and breaks. |
| 24. | All threaded parts | Look for damaged threads. |

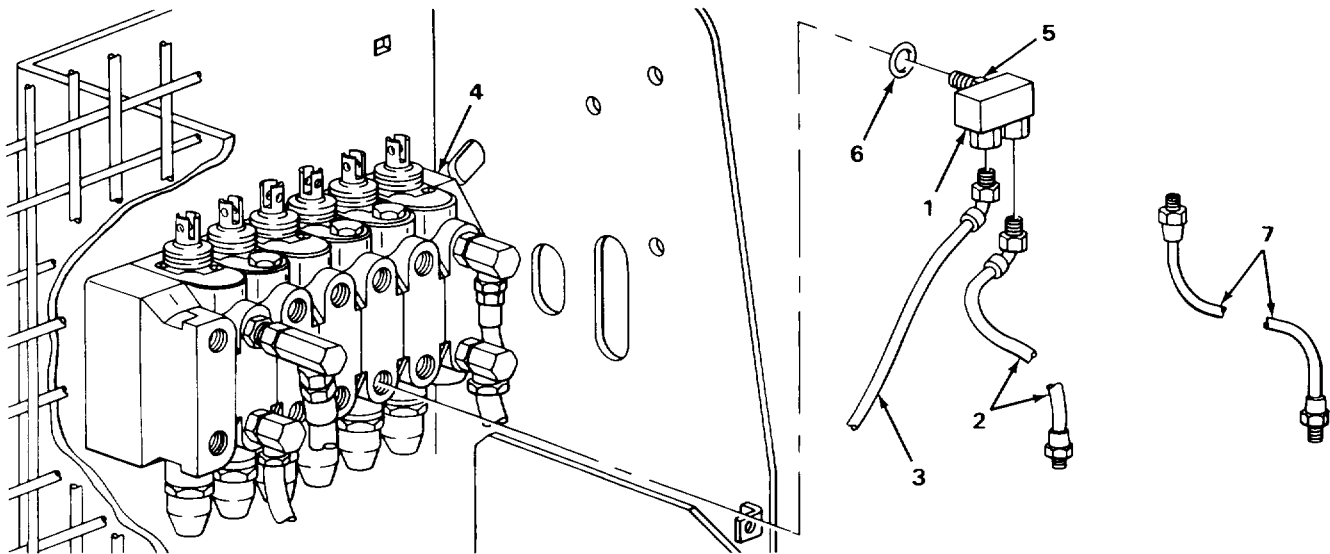

TA243520A

BACKHOE CONTROL VALVE-TO-BACKHOE STABILIZER CYLINDER OIL LINES - CONTINUED

LOCATION	ITEM	ACTION REMARKS
INSTALLATION		
25. Special union adapter (1)	Nut (2)	Screw on all the way.
26.	New packing (3)	Place in position.
27. Backhoe control valve (4)	Special union adapter (1) with assembled parts	a. Unplug valve(4). b. Screw in and tighten to same position noted during removal, using 1-inch open-end wrench.
28. Special union adapter (1) and backhoe control valve (4)	Nut (2)	Using two 1-inch open-end wrenches, tighten until seated against valve (4).
29. Special union adapter (1)	Two hoses (5 and 6)	a. Take off tags. b. Take cap off hose (5). c. Screw in and tighten using 3/4-inch and 7/8-inch open-end wrenches.
30. Union adapter (7)	Nut (8)	Screw on all the way.
31.	New packing (9)	Place in position.
32. Swing cylinder (10)	Union adapter (7) with assembled parts	a. Unplug cylinder(10). b. Screw in and tighten to position noted during removal, using 5/8-inch open-end wrench.
33. Union adapter (7) and swing cylinder (10)	Nut (8)	Using 5/8-inch and 11/16-inch open-end wrenches, tighten until seated against cylinder (10).
34. Union Hose (6) adapter (7)		a. Take off tag. b. Screw together and tighten using 7/8-inch and 1-inch open-end wrenches for right side, or 7/8-inch and 11/16-inch open-end wrenches for left side.
35. Special union adapter (11)	Nut (12)	Screw on all the way.
36.	New packing (13)	Place in position.

BACKHOE CONTROL VALVE-TO-BACKHOE STABILIZER CYLINDER OIL LINES - CONTINUED

LOCATION	ITEM	ACTION	REMARKS
37. Backhoe control valve (4)	Special union adapter (11) with assembled parts	a. Unplug control valve (4). b. Screw in to same relative position as noted during removal using 1-inch open-end wrench.	
38. Backhoe control valve (4) and special union adapter (11)	Nut (12)		Using two 1-inch open-end wrenches, tighten until seated against control valve (4).
39. Four adapters (14) packings (15)	Four new	Place in position.	
40. Backhoe control valve (4)	Four adapters (14) with assembled packings (15)	a. Unplug valve (4). b. Screw in and tighten using 1-inch, 1/2-inch drive deep socket and ratchet handle.	

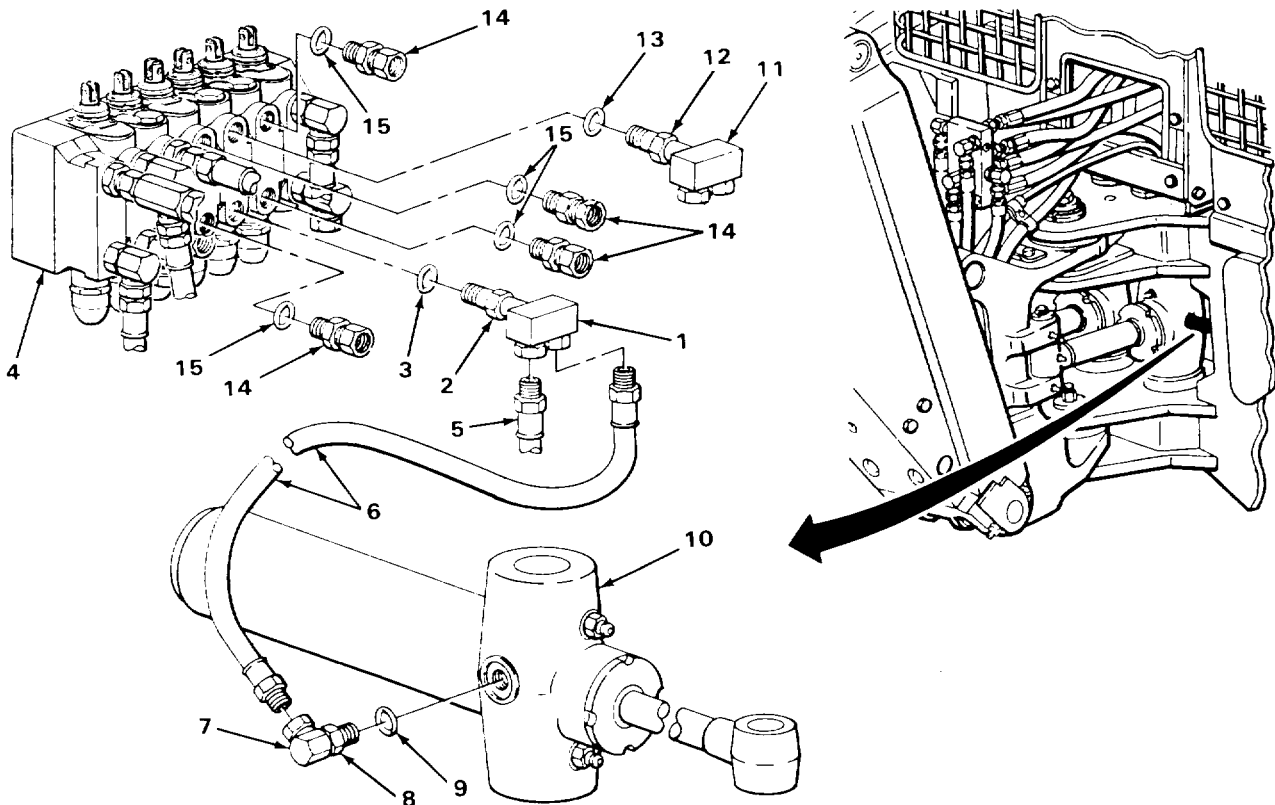

TA243520B

BACKHOE CONTROL VALVE-TO-BACKHOE STABILIZER CYLINDER OIL LINES - CONTINUED

LOCATION	ITEM	ACTION REMARKS
INSTALLATION - CONTINUED		
41. Four adapters (1)	Four hoses (2)	a. Take off tags. b. Take off caps. c. Screw in and tighten using 7/8-inch and 1-inch open-end wrenches.
42. Special union adapter (3)	Two hoses (4 and 5)	a. Take off tags. b. Take cap off hose (3). c. Screw in and tighten using 7/8-inch and 11/16-inch open-end wrenches.
43. Union adapter (6)	Nut (7)	Screw on all the way.
44.	New packing (8)	Place in position.
45. Swing cylinder (9)	Union adapter (6) with assembled parts	a. Unplug cylinder (7). b. Screw in and tighten to same relative position as noted during removal using 7/8-inch open-end wrench.
46. Union adapter (6) and swing cylinder (9)	Nut (7)	Using two 7/8-inch open-end wrenches, tighten until seated against cylinder (7).
47. Union adapter (6)	Hose (4)	a. Take off tag. b. Screw in and tighten using 11/16-inch and 7/8-inch open-end wrenches for right side, or 7/8-inch and 1-inch open-end wrenches for left side.
48. Handle mount (10)	Four way lever (11)	Screw in to position noted during removal.
49. Handle mount (10) and four way lever (11)	Nut (12)	Using 15/16-inch open-end wrench, tighten until seated against handle mount (8).
50. Loader backhoe	Transmission	Check fluid level and add proper amount and grade (TM 5-2420-222-10).
51.	Engine	Start and run at high idle (TM 5-2420-222-10).

BACKHOE CONTROL VALVE-TO-BACKHOE STABILIZER CYLINDER OIL LINES - CONTINUED

LOCATION	ITEM	ACTION	REMARKS
52.	Backhoe control valve-to-swing cylinder oil lines	<ul style="list-style-type: none"> a. Operate backhoe controls (TM 5-2420-222-10) and check for leaks. b. If leaking at any connection, tighten using 5/8-inch, 11/16-inch, 3/4-inch, two 7/8-inch, and two 1-inch open-end wrenches. c. If leaking does not stop, shut down engine (TM 5-2420-222-10) and replace leaking connection packing, fitting, or hose as outlined in this task. d. If found leaking repeat steps 50 thru 52. 	
53.	Engine	If still running, shut down (TM 5-2420-222-10).	

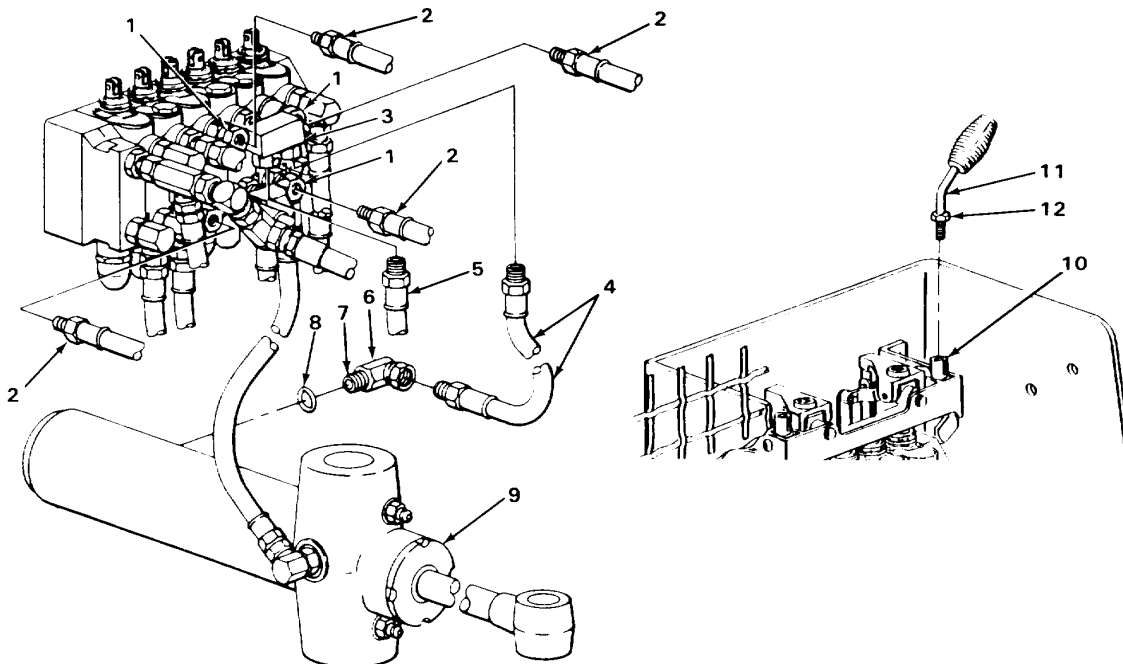

TA243521

BACKHOE CONTROL VALVE-TO-BACKHOE STABILIZER CYLINDER OIL LINES - CONTINUED

LOCATION	ITEM	ACTION	REMARKS
INSTALLATION - CONTINUED			
54. Handle mount (1) and four way lever (2)	Nut (3)	Using 15/16-inch open-end wrench, loosen.	
55. Handle mount (1)	Four way lever (2)	a. Note relative position for proper placement during installation. b. Unscrew and take out.	

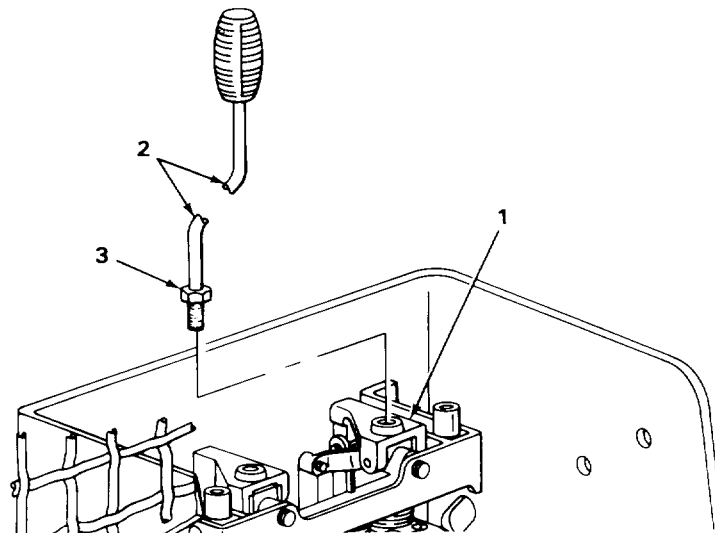

NOTE

FOLLOW-ON MAINTENANCE: Install backhoe valve box cover (page 2-1157).

TASK ENDS HERE

TA243522

PRESSURE CONTROL VALVE-TO-LOADER CONTROL VALVE OIL LINE

This task covers:

- | | |
|---------------------------|---|
| a. Removal (page 2-1648) | c. Inspection/Replacement (page 2-1650) |
| b. Cleaning (page 2-1648) | d. Installation (page 2-1650) |
-

INITIAL SETUP

Tools

Knife, pocket
 Pan, drain
 Wrench, open-end, 7/8-inch
 Wrench, open-end, 1 11/16-inch
 Wrench, open-end, 1 1/4-inch

Materials/Parts

Packing, elbow
 Packing, special connector
 Rags, wiping (item 21, Appendix C)
 Solvent, drycleaning (item 28,
 Appendix C)
 Tags, marking (item 30, Appendix C)

Personnel Required

One

Equipment Condition

1. Right platform removed (page 2-1079)
2. Transmission oil filter removed (page 2-836)

2-1647

BACKHOE CONTROL VALVE-TO-BACKHOE STABILIZER CYLINDER OIL LINES - CONTINUED

LOCATION	ITEM	ACTION REMARKS
REMOVAL		
1. Tee (1)	Hose (2)	a. Place drain pan underneath. b. Using 7/8-inch and 1-inch open-end wrenches, unscrew and take out. c. Cap (page 2-137). d. Tag (page 2-137).
2. Special connector (3)	Line (4)	a. Using 1-inch and 1 1/4-inch open-end wrenches, unscrew and that off. b. Tag (page 2-137).
3. Elbow (5) Line (4)		a. Using 1-inch and 1 1/4-inch open-end wrenches, unscrew and take off. b. Tag (page 2-137).
4. Pressure control valve (6) and elbow (5)	Nut (7)	Using 1 1/16-inch and 1 1/4-inch open-end wrenches, loosen.
5. Pressure control valve (6)	Elbow (5) with assembled parts	a. Note relative position for proper placement during installation. b. Using 1 1/16-inch open-end wrench, unscrew and take out. c. Plug valve (6) (page 2-137).
6. Elbow (5)	Packing (8)	a. Using pocket knife, take off. b. Get rid of.
7. Loader control valve (9)	Special connector (3) with assembled packing (10)	a. Using 1 1/4-inch open-end wrench, unscrew and take out. b. Plug valve (9) (page 2-137). c. Get rid of drained fluid (page 2-137).
8. Special connector (3)	Packing (10)	a. Using pocket knife, take off. b. Get rid of.

CLEANING
NOTE

For more information on how to clean parts, go to **General Maintenance Instructions (page 2-137)**.

PRESSURE CONTROL VALVE-TO-LOADER CONTROL VALVE OIL LINE - CONTINUED

LOCATION	ITEM	ACTION	REMARKS
----------	------	--------	---------

WARNING

Drycleaning solvent P-D-680 is toxic and flammable. Wear protective goggles and gloves and use only in a well ventilated area. Avoid contact with skin, eyes, and clothes and don't breathe vapors. Do not use near open flame or excessive heat. The flashpoint is 100° to 138° (38° to 59°C). If you become dizzy while using cleaning solvent, get fresh air immediately and get medical aid. If contact with eyes is made, wash your eyes with water and get medical aid immediately.

- | | | |
|-----|-----------------------|---|
| 9. | Line (4) | <ul style="list-style-type: none"> a. Using clean rags dampened in drycleaning solvent, wipe clean. b. Using clean, dry rags, wipe dry. |
| 10. | All other metal parts | <ul style="list-style-type: none"> a. Clean in drycleaning solvent. b. Using clean, dry rags, wipe dry. |

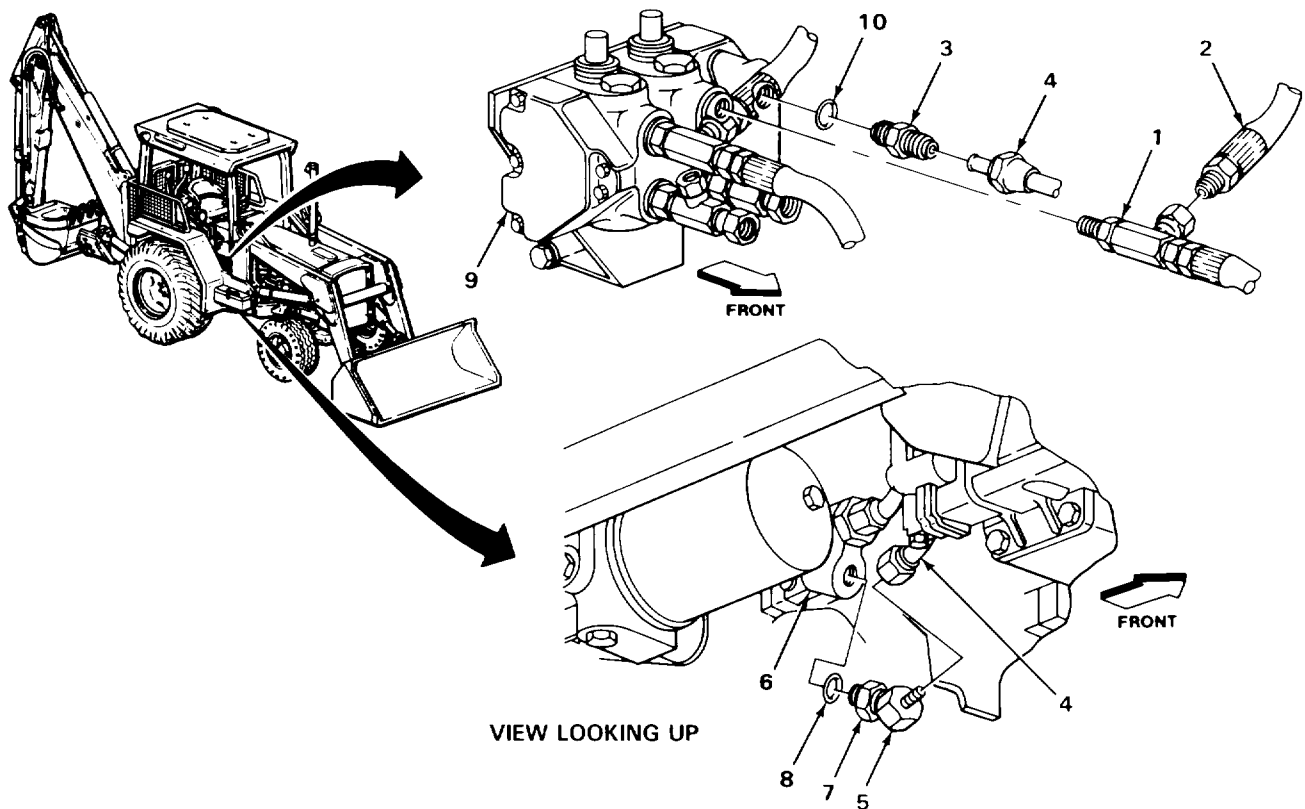

PRESSURE CONTROL VALVE-TO-LOADER CONTROL VALVE OIL LINE - CONTINUED

LOCATION	ITEM	ACTION	REMARKS
INSPECTION/REPLACEMENT			
NOTE			
For more information on how to inspect parts, go to General Maintenance Instructions (page 2-137).			
Replace defective parts as needed.			
11.	All metal parts		Look for cracks, breaks, and abnormal bends.
12.	All threaded parts		Look for damaged threads.
INSTALLATION			
13.	Special connector (1)	New packing (2)	Place in position.
14.	Loader control valve (3)	Special connector (1) with assembled packing (2)	a. Unplug valve (3). b. Screw in and tighten using 1 1/4-inch open-end wrench.
15.	Elbow (4)	Nut (5)	Screw on all the way.
16.		New packing (6)	Place in position.
17.	Pressure control valve (7)	Elbow (4) with assembled parts	a. Unplug valve (7). b. Screw into same relative position as noted during removal using 1 1/16-inch open-end wrench.
18.	Pressure control valve (7) and elbow (4)	Nut (5)	Using 1 1/16-inch and 1 1/4-inch open-end wrenches, tighten until seated against valve (7).
19.	Elbow (4)	Line (8)	a. Take off tag. b. Screw on and tighten using 1-inch and 1 1/4-inch open-end wrenches.
20.	Special connector (1)	Line (8)	a. Take off tag. b. Screw on and tighten using 1-inch and 1 1/4-inch open-end wrenches.

PRESSURE CONTROL VALVE-TO-LOADER CONTROL VALVE OIL LINE - CONTINUED

LOCATION	ITEM	ACTION	REMARKS
21. Tee(9)	Hose(10)	a. Uncap. b. Take off tag. c. Screw in and tighten using 7/8-inch and 1-inch open-end wrenches.	
22. Loader backhoe	Transmission oil filter	Install (page 2-836).	
23.	Transmission	Check fluid level and add proper amount and grade (TM 5-2420-222-10).	
24.	Engine	Start and run at high idle (TM 5-2420-222-10).	

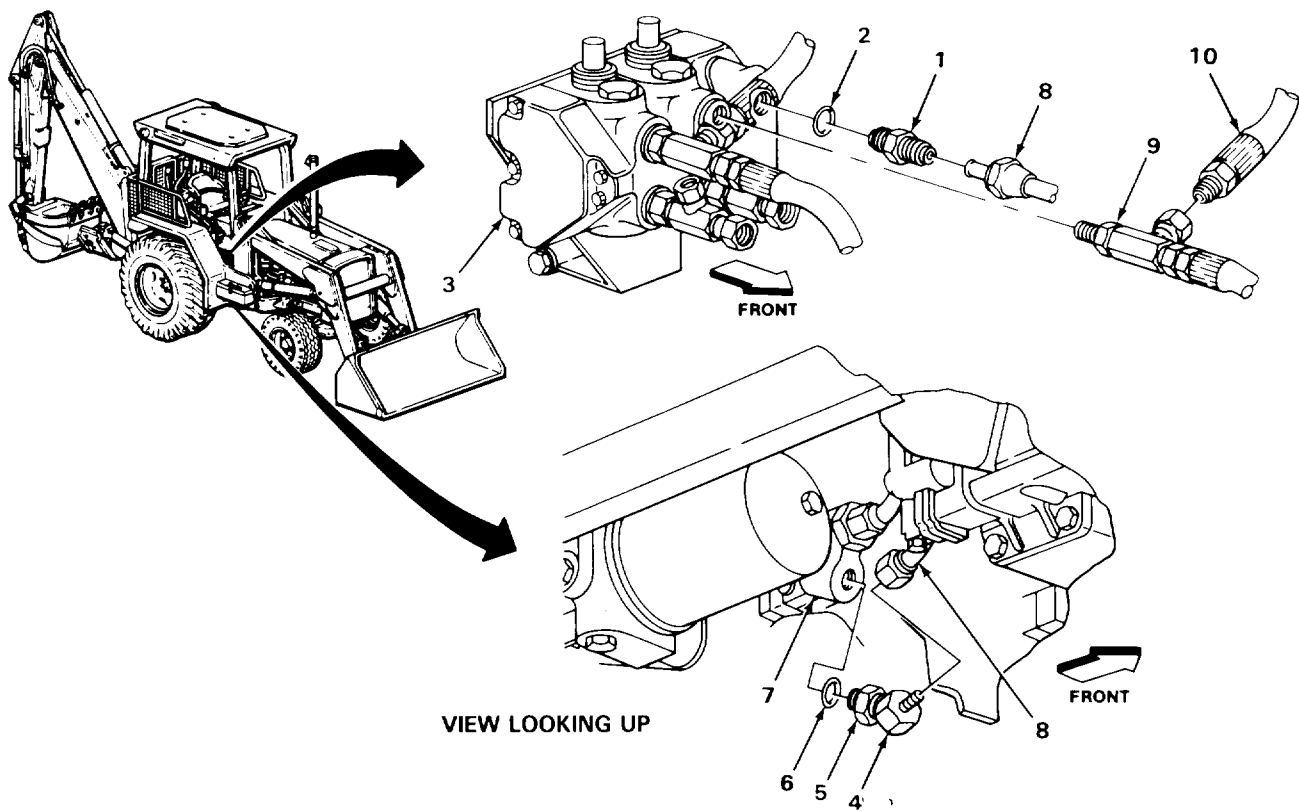

TA243524

PRESSURE CONTROL VALVE-TO-LOADER CONTROL VALVE OIL LINE - CONTINUED

LOCATION	ITEM	ACTION	REMARKS
INSTALLATION - CONTINUED			
25.	Pressure control valve-to-loader control valve oil line	<ul style="list-style-type: none"> a. Operate loader controls (TM 5-2420-222-10) and check for leaks. b. If leaking at any connection, tighten using 7/8-inch, 1-inch, 1 1/16-inch, and 1 1/4-inch open-end wrenches. c. If leaking does not stop, shut down engine (TM 5-2420-222-10) and replace leaking connection packing, fitting, or line as outlined in this task. d. If found leaking, repeat steps 23 thru 25. 	
26.	Engine		If still running, shut down (TM 5-2420-222-10).

NOTE

FOLLOW-ON MAINTENANCE: Install right platform (page 2-1079).

TASK ENDS HERE

LOADER CONTROL VALVE-TO-HYDRAULIC OIL FILTER RELIEF VALVE OIL LINE

This task covers:

- | | |
|---------------------------|---|
| a. Removal (page 2-1654) | c. Inspection/Replacement (page 2-1657) |
| b. Cleaning (page 2-1656) | d. Installation (page 2-1657) |
-

INITIAL SETUP**Tools**

Knife, pocket
 Pan, drain
 Screwdriver, flat-tip, 1/4-inch
 Wrench, open-end, 7/8-inch
 (two required)
 Wrench, open-end, 1 1/4-inch
 (two required)

Materials/Parts

Detergent, GP (item 7, Appendix C)
 Packing, long tee
 Packing, lower connector

Materials/Parts - Continued

Packing, upper connector
 Rags, wiping (item 21, Appendix C)
 Solvent, drycleaning (item 28, Appendix C)
 Tags, marking (item 30, Appendix C)

Personnel Required

One

Equipment Condition

Hydraulic oil filter relief valve-to-clutch
 control valve adapter oil line removed
 (page 2-1346)

LOADER CONTROL VALVE-TO-HYDRAULIC OIL FILTER RELIEF VALVE OIL LINE

LOCATION	ITEM	ACTION	REMARKS
----------	------	--------	---------

REMOVAL**WARNING**

Do not attempt to disconnect hydraulic lines and fittings while engine is running or before hydraulic system pressure has been released. When engine is running, hydraulic system is under pressure. Hydraulic system pressure should be 0 psi (0 kPa) before lines are disconnected. A line or fitting disconnected under pressure will blow off with a lot of force and could cause serious injury to personnel.

Be careful when draining hot fluids. Wear gloves to protect your hands from hot parts and fluids or severe burns could result.

- | | | |
|--|--|--|
| 1. Long tee (1) | Two hoses (2 and 3) | a. Place drain pan underneath.
b. Using 7/8-inch and 1-inch open-end wrenches, unscrew and take out.
c. Cap (page 2-137).
d. Tag (page2-137). |
| 2. Loader control valve (4) and long tee (1) | Nut (5) | Using two 1-inch open-end wrenches, loosen. |
| 3. Loader control valve (4) | Long tee (1) with assembled parts | a. Note relative position for proper placement during installation.
b. Using 1-inch open-end wrench, unscrew and take out. |
| 4. Long tee (1) | Packing (6) | a. Using pocket knife, take off.
b. Get rid of. |
| 5. Connector (7) | Oil line (8) | a. Using two 1 1/4-inch open-end wrenches, unscrew and take out.
b. Tag (page 2-137). |
| 6. Loader control valve (4) | Connector (7) with assembled packing (9) | a. Using 1 1/4-inch open-end wrench, unscrew and take out.
b. Plug valve (4) (page 2-137). |
| 7. Connector (7) | Packing (9) | a. Using pocket knife, take off.
b. Get rid of. |
| 8. Hose (10) | Clamp (11) | Using 1/4-inch flat-tip screwdriver, loosen. |

LOADER CONTROL VALVE-TO-HYDRAULIC OIL FILTER RELIEF VALVE OIL LINE

LOCATION	ITEM	ACTION	REMARKS
9.	Oil line (8)	a. Note relative position for proper placement during installation. b. Pull out. c. Tag (2-137).	
10.	Clamp (11)	Slide off.	

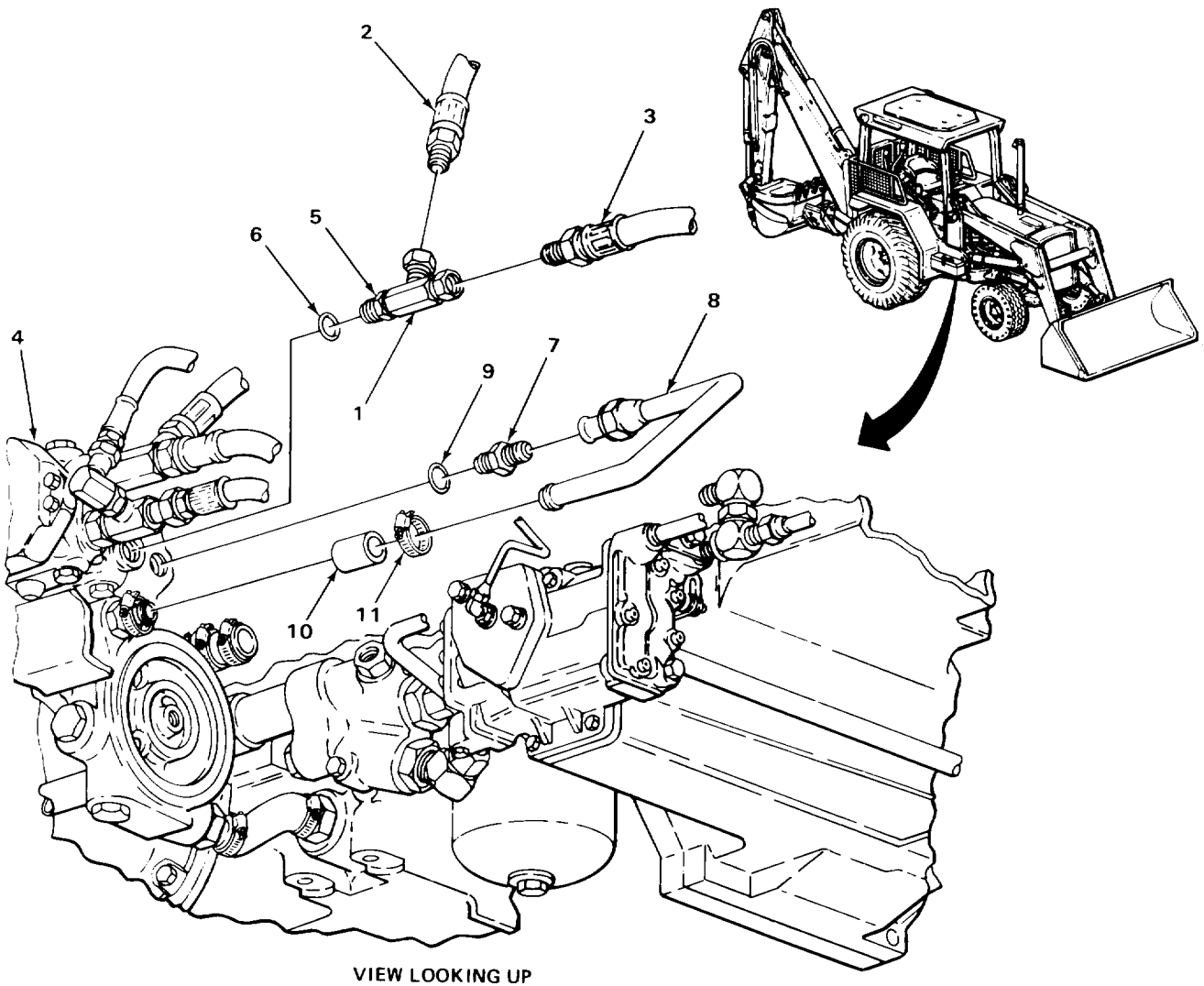

LOADER CONTROL VALVE-TO-HYDRAULIC OIL FILTER RELIEF VALVE OIL LINE

LOCATION	ITEM	ACTION	REMARKS
REMOVAL - CONTINUED			
11. Hose (1)	Clamp (2)	a. Using 1/4-inch flat-tip screwdriver, loosen. b. Slide off.	
12. Connector (3)	Hose (1)	Pull off.	
13. Hydraulic oil filter relief valve (4)	Connector (3) with assembled packing (5)	a. Using 1 1/4-inch open-end wrench, unscrew and take out. b. Plug valve (4).	
14. Connector (3)	Packing (5)	a. Using pocket knife, take off. b. Get rid of.	

CLEANING**NOTE**

For more information on how to clean parts, go to General Maintenance Instructions (page 2-137).

- | | |
|--------------|---|
| 15. Hose (1) | a. Using clean rags dampened in solution of detergent and water, wipe clean.
b. Rinse with clean water.
c. Using clean, dry rags, wipe dry. |
|--------------|---|

WARNING

Drycleaning solvent P-D-680 is toxic and flammable. Wear protective goggles and gloves and use only in a well ventilated area. Avoid contact with skin, eyes, and clothes and don't breathe vapors. Do not use near open flame or excessive heat. The flashpoint is 100° to 138° (38° to 59°C). If you become dizzy while using cleaning solvent, get fresh air immediately and get medical aid. If contact with eyes is made, wash your eyes with water and get medical aid immediately.

- | | | |
|-----|-----------------------|---|
| 16. | Oil line (6) | a. Using clean rags dampened in drycleaning solvent, wipe clean.
b. Using clean, dry rags, wipe dry. |
| 17. | All other metal parts | a. Clean in drycleaning solvent.
b. Using clean, dry rags, wipe dry. |

LOADER CONTROL VALVE-TO-HYDRAULIC OIL FILTER RELIEF VALVE OIL LINE

LOCATION	ITEM	ACTION	REMARKS
----------	------	--------	---------

INSPECTION/REPLACEMENT

NOTE

For more information on how to inspect parts, go to **General Maintenance Instructions (page 2-137)**.

Replace defective parts as needed.

18.	Hose (1)	Check for cuts, cracks, and breaks.
19.	All metal parts	Look for cracks, breaks, and abnormal bends.
20.	All threaded parts	Look for damaged threads.

INSTALLATION

21. Connector (3)	New packing (5)	Place in position.
22. Hydraulic oil filter relief valve (4)	Connector (3) with assembled packing (5)	Screw in and tighten using 1 1/4-inch open-end wrench.

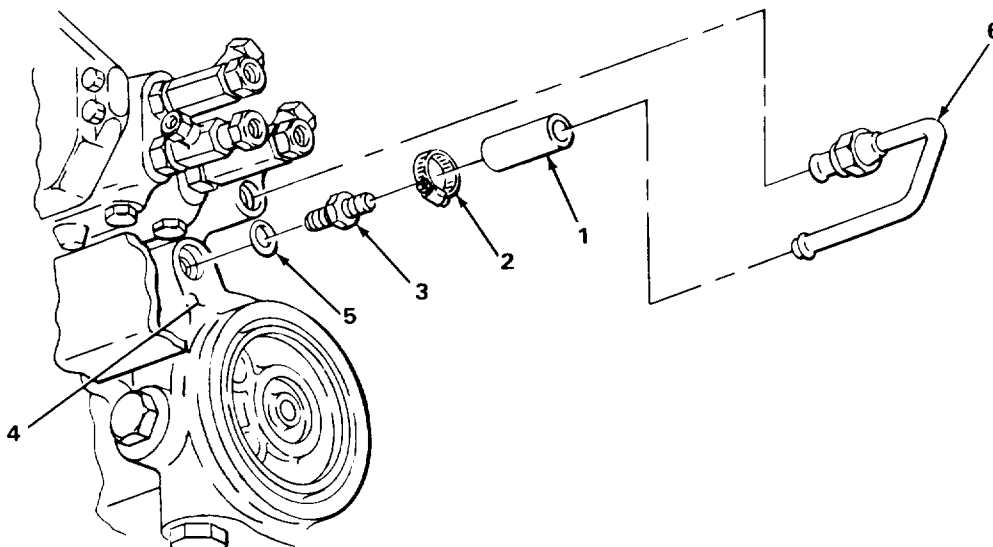

TA243526

LOADER CONTROL VALVE-TO-HYDRAULIC OIL FILTER RELIEF VALVE OIL LINE

LOCATION	ITEM	ACTION REMARKS
INSTALLATION - CONTINUED		
NOTE		
<p>New hoses for loader backhoes with Serial Numbers 235786 thru 235999 are precut to proper length. New hoses for loader backhoes with Serial Numbers 319995 thru 342573 are manufactured from bulk items. For more information on manufacturing new hoses, go to Appendix D.</p>		
23. Connector (1)	Hose (2)	Slide on.
24. Hose (2)	Clamp (3)	a. Place in position. b. Using 1/4-inch flat-tip screwdriver, tighten.
25.	Clamp (4)	Place in position.
26.	Oil line (5)	a. Place in same relative position noted during removal. b. Take off tag.
27.	Clamp (4)	Using 1/4-inch flat-tip screwdriver, tighten.
28. Connector (6)	New packing (7)	Place in position.
29. Loader control valve (8)	Connector (6)	a. Unplug valve (8). b. Screw in and tighten using 1 1/4-inch open-end wrench.
30. Connector (6)	Oil line (5)	a. Take off tag. b. Screw on and tighten using two 1 1/4-inch open-end wrenches.
31. Long tee (9)	Nut (10)	Screw on all the way.
32.	New packing (11)	Place in position.
33. Loader control valve (8)	Long tee (9) with assembled parts	a. Unplug valve (8). b. Screw in and tighten to position noted during removal using 1-inch open-end wrench.
34. Loader control valve (8) and long tee (9)	Nut (10)	Using two 1-inch open-end wrenches, tighten until seated against valve (8).

LOADER CONTROL VALVE-TO-HYDRAULIC OIL FILTER RELIEF VALVE OIL LINE

LOCATION	ITEM	ACTION	REMARKS
35. Long tee (9)	Two hoses (12 and 13)	a. Uncap. b. Take off tags. c. Screw on and tighten using 7/8-inch and 1-inch open-end wrenches.	

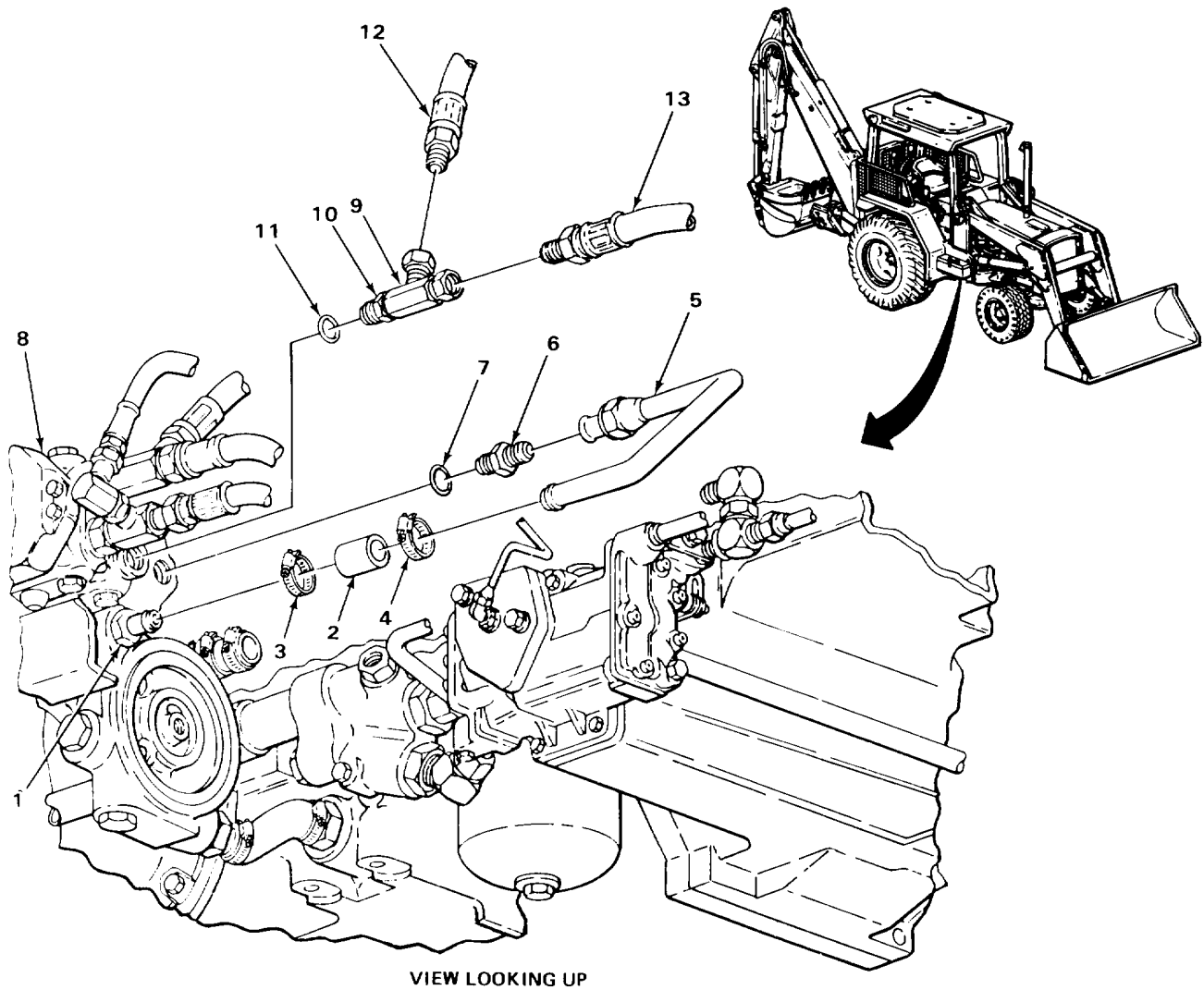

VIEW LOOKING UP

LOADER CONTROL VALVE-TO-HYDRAULIC OIL FILTER RELIEF VALVE OIL LINE

LOCATION	ITEM	ACTION REMARKS
INSTALLATION		
36. Loader backhoe	Hydraulic oil filter relief valve-to-clutch control valve adapter oil line	Install (page 2-1346).
37.	Transmission	Check fluid level and add proper amount and grade (TM 5-2420-222-10).
38.	Engine	Start and run at high idle (TM 5-2420-222-10).
39.	Loader control valve-to-hydraulic oil filter relief valve oil line	<ul style="list-style-type: none"> a. Operate loader controls (TM 5-2420-222-10) and check for leaks. b. If leaking at any connection, tighten using 1/4-inch flat-tip screwdriver, 7/8-inch, two 1-inch, and two 1 1/4-inch open-end wrenches. c. If leaking does not stop, shut down engine (TM 5-2420-222-10) and replace leaking connection packing, fitting, or oil line as outlined in this task. d. If found leaking, repeat steps 37 thru 39.
40. Engine	If still running, shut down (TM 5-2420-222-10).	

TASK ENDS HERE

LOADER CONTROL VALVE-TO-HYDRAULIC OIL FILTER RELIEF VALVE OIL LINE

This task covers:

- | | |
|---|--|
| <ul style="list-style-type: none"> a. Removal (page 2-1662) b. Cleaning (page 2-1664) | <ul style="list-style-type: none"> c. Inspection/Replacement (page 2-1666) d. Installation (page 2-1666) |
|---|--|

INITIAL SETUP

Tools

- Handle, ratchet, 3/8-inch drive
- Knife, pocket
- Screwdriver, flat-tip, 1/4-inch
- Socket, 3/8-inch drive, 9/16-inch
- Wrench, open-end, 7/8-inch
- Wrench, open-end, 1-inch
(two required)

Personnel Required

One

Equipment Condition

1. Hydraulic oil filter removed
(page 2-1698)
2. Right platform removed (page 2-1079)

Materials/Parts

- Detergent, GP (item 7, Appendix C)
- Lockwasher, clamp screw
- Packing, pipe nipple
- Packing, long tee
- Rags, wiping (item 21, Appendix C)
- Solvent, drycleaning (item 28,
Appendix C)
- Tags, marking (item 30, Appendix C)

LOCATION	ITEM	ACTION	REMARKS
----------	------	--------	---------

NOTE

Both loader control valve-to-loader bucket cylinder head end oil lines are maintained the same way except as noted. Left oil line is shown. Repeat procedures as needed for right oil line.

2-1661

LOADER CONTROL VALVE-TO-LOADER BUCKET CYLINDER HEAD END OIL LINES - CONTINUED

LOCATION	ITEM	ACTION REMARKS
REMOVAL		
1. Line (1)	Hose (2)	a. Place drain pan underneath. b. Using 7/8-inch and 1-inch open-end wrenches, unscrew and take out. c. Tag (page 2-137).
2. Loader bucket cylinder (3) and two oil lines (1 and 4)	Two clamps (5 and 6)	a. Note relative positions for proper placement during installation. b. Using 1/4-inch flat-tip screwdriver, loosen and take off.
3. Adapter (7)	Oil line (1)	a. Place drain pan underneath. b. Using 7/8-inch and 1-inch open-end wrenches, unscrew and take out. c. Tag (page 2-137).
4. Loader bucket cylinder (3)	Adapter (7) with assembled packing (8)	a. Using 1-inch open-end wrench, unscrew and take out. b. Plug cylinder (3) (page 2-137).
5. Adapter (7)	Packing (8)	a. Using pocket knife, take off. b. Get rid of.
NOTE		
If removing loader control valve-to-right loader bucket cylinder oil line, skip steps 6 thru 8.		
6. Left side frame (9), spacer (10) and clamp (11)	Four hoses (2, 12, 13, and 14)	Tag (page 2-137).
7.	Screw (15) and lockwasher (16)	a. Using 9/16-inch, 3/8-inch drive socket and ratchet handle, unscrew and take out. b. Get rid of lockwasher (16).
8. Left side frame (9)	Clamp (11), spacer (10) and four hoses (2, 12, 13 and 14)	a. Note relative position of hoses (2, 12, 13, and 14) for proper placement during installation b. Take off.

LOADER CONTROL VALVE-TO-LOADER BUCKET CYLINDER HEAD END OIL LINES - CONTINUED

LOCATION	ITEM	ACTION	REMARKS
----------	------	--------	---------

9 Tee (17)

Union (18) with assembled parts

- a Place drain pan underneath.
- b Using two 1-inch open-end wrenches, unscrew and take out.
- c Cap (page 2-137).
- d Tag (page 2-137).
- e Plug tee (17) (page 2-137).

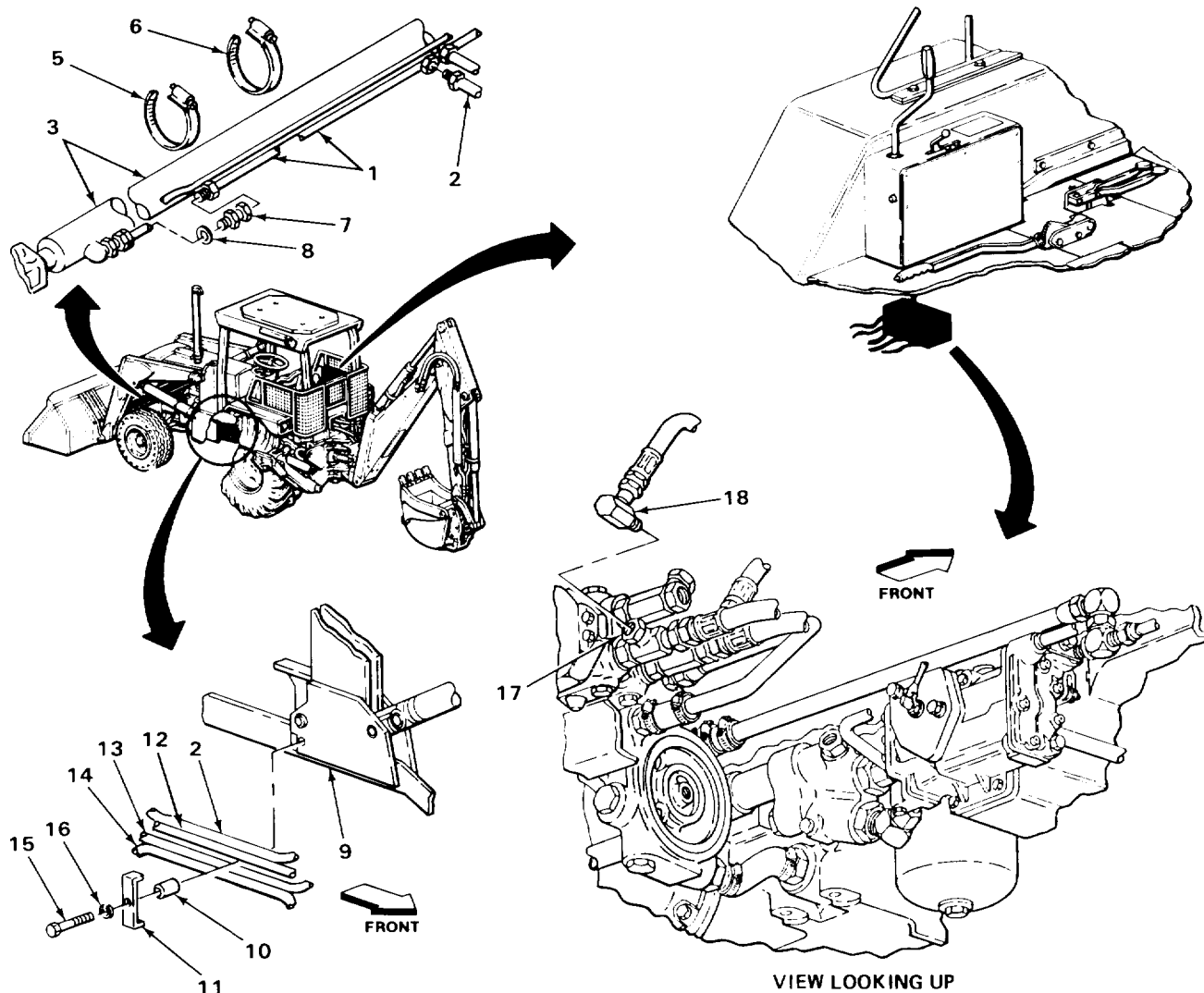

LOADER CONTROL VALVE-TO-LOADER BUCKET CYLINDER HEAD END OIL LINES - CONTINUED

LOCATION	ITEM	ACTION REMARKS
REMOVAL - CONTINUED		
10 Tee (1)	Hose (2)	<ul style="list-style-type: none"> a Using 7/8-inch and 1-inch open-end wrenches, unscrew and take out. b Cap (page 2-137). c Tag (page 2-137). d Plug tee (1) (page 2-137).
11 Long tee (3)	Two hoses (4 and 5)	<ul style="list-style-type: none"> a Using 7/8-inch and 1-inch open-end wrenches, unscrew and take out. b Cap hose (4 or 5) (page 2-137) if removed for access. c Tag (page 2-137).
12 Loader control valve (6) and long tee (3)	Nut (7) loosen.	Using two 1-inch open-end wrenches,
13 Loader control valve (6)	Long tee (3) with assembled parts	<ul style="list-style-type: none"> a Note relative position for proper placement during installation. b Using 1-inch open-end wrench, unscrew and take out. c Plug valve (6) (page 2-137). d Get rid of drained fluid (page 2-137).
14 Long tee (3)	Packing (8)	<ul style="list-style-type: none"> a Using pocket knife, take off. b Get rid of.

CLEANING**NOTE**

For more information on how to clean parts, go to General Maintenance Instructions (page 2-137).

15	Hose (4 or 5)	<ul style="list-style-type: none"> a Using clean rags dampened in solution of detergent and water, wipe clean. b Rinse with clean water. c Using clean, dry rags, wipe dry.
----	---------------	--

LOADER CONTROL VALVE-TO-LOADER BUCKET CYLINDER HEAD END OIL LINES - CONTINUED

LOCATION	ITEM	ACTION	REMARKS
----------	------	--------	---------

WARNING

Drycleaning solvent P-D-680 is toxic and flammable. Wear protective goggles and gloves and use only in a well ventilated area. Avoid contact with skin, eyes, and clothes and don't breathe vapors. Do not use near open flame or excessive heat. The flashpoint is 100°F to 138°F (38° to 59°C). If you become dizzy while using cleaning solvent, get fresh air immediately and get medical aid. If contact with eyes is made, wash your eyes with water and get medical aid immediately.

- | | | |
|----|-----------------------|--|
| 16 | Oil line (9) | <ul style="list-style-type: none"> a Using clean rags dampened in dry-cleaning solvent, wipe clean. b Using clean, dry rags, wipe dry. |
| 17 | All other metal parts | <ul style="list-style-type: none"> a Clean in drycleaning solvent. b Using clean, dry rags, wipe dry. |

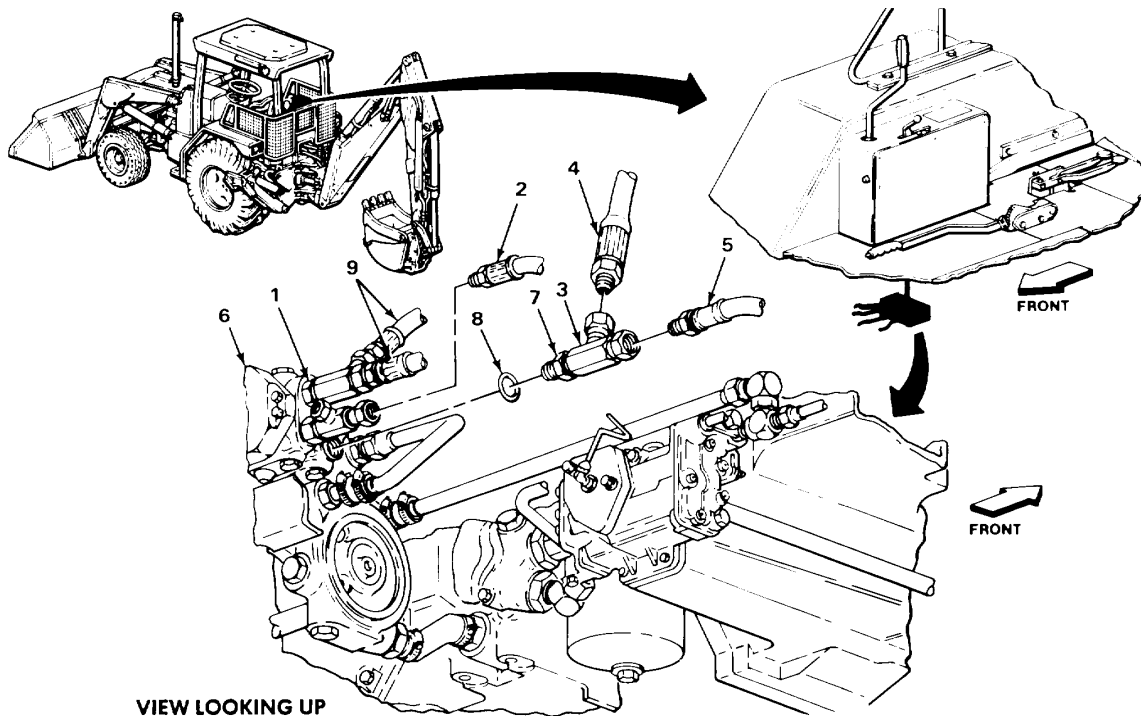

TA243529

LOADER CONTROL VALVE-TO-LOADER BUCKET CYLINDER HEAD END OIL LINES - CONTINUED

LOCATION	ITEM	ACTION	REMARKS
INSPECTION/REPLACEMENT			
NOTE			
For more information on how to inspect parts, go to General Maintenance Instructions (page 2-137) .			
Replace defective parts as needed.			
18	Hose (1 or 2)		Look for cracks, breaks, cuts, and tears.
19	All metal parts		Look for cracks, breaks, and abnormal bends.
20	All threaded parts		Look for damaged threads.
INSTALLATION			
21. Long tee (3)	Nut (4)		Screw on all the way.
22.	New packing (5)		Place in position.
23. Loader control valve (6)	Long tee (3) with assembled parts	<ul style="list-style-type: none"> a. Unplug valve (6). b. Screw in and tighten to same relative position noted during removal using 1-inch open-end wrench. 	
24. Loader control valve (6) and long tee (3)	Nut (4)		Using two 1-inch open-end wrenches, tighten until seated against valve (6).
25. Long tee (3)	Hose (1 and 2)	<ul style="list-style-type: none"> a. Uncap hose (1 or 2) if removed for access. b. Take off tags. c. Screw in and tighten using 7/8-inch and 1-inch open-end wrenches. 	
26. Tee(7)	Hose (8)	<ul style="list-style-type: none"> a. Uncap. b. Take off tag. c. Unplug tee(7). d. Screw in and tighten using 7/8-inch and 1-inch open-end wrenches. 	

LOADER CONTROL VALVE-TO-LOADER BUCKET CYLINDER HEAD END OIL LINES - CONTINUED

LOCATION	ITEM	ACTION REMARKS
27. Tee (7)	Union (9) with assembled parts	a. Uncap. b. Take off tag. c. Unplug tee(7). d. Screw in and tighten using two 1-inch open-end wrenches.
NOTE		
If installing loader control valve-to-right loader bucket cylinder oil line, skip steps 28 thru 30.		
28. Left side frame (10)	Four hoses (1, 11, 12, and 13), spacer (14), and clamp (15)	Place in same relative positions noted during removal.
29. Left side frame (10), spacer (14)	Screw (16) and new lockwasher (17)	Screw in and tighten using 9/16-inch, 3/8-inch drive socket and ratchet handle.

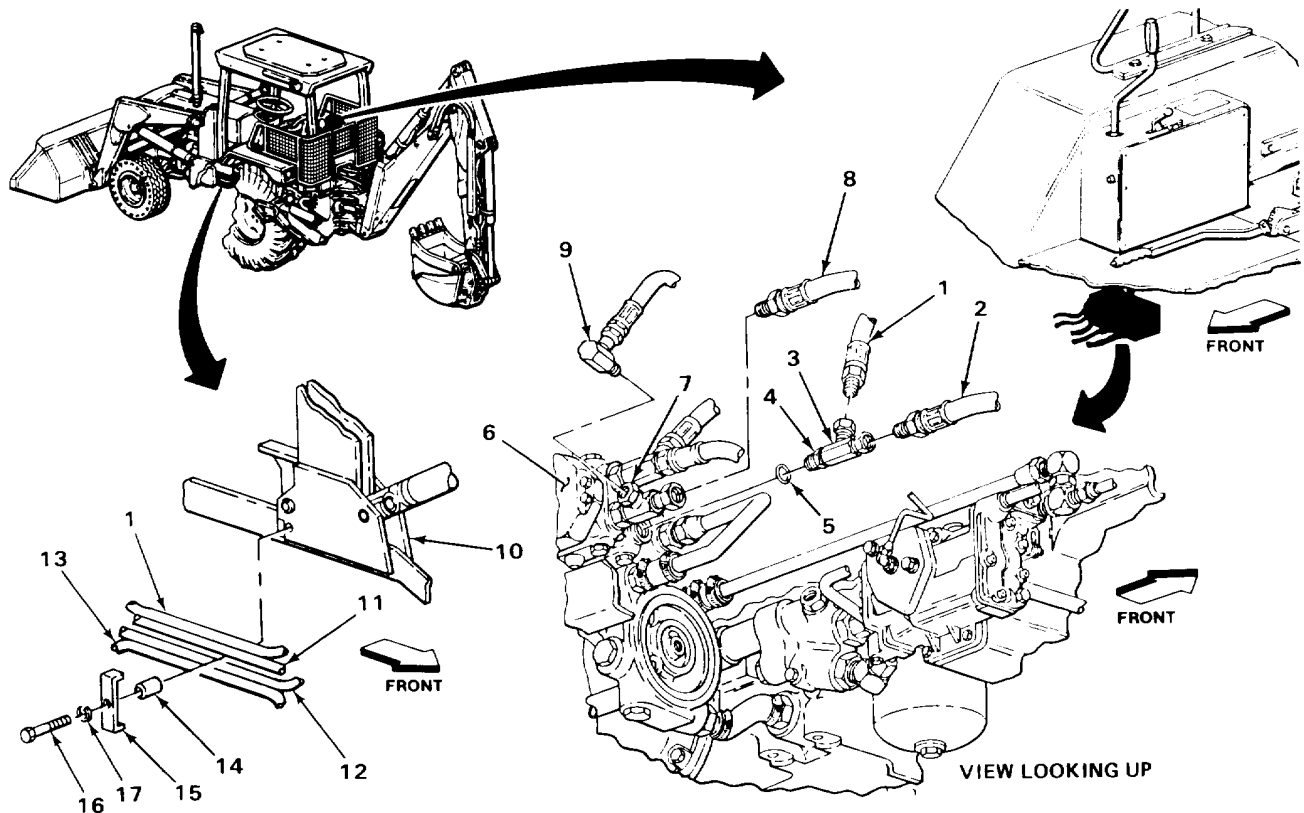

LOADER CONTROL VALVE-TO-LOADER BUCKET CYLINDER HEAD END OIL LINES - CONTINUED

LOCATION	ITEM	ACTION REMARKS
INSTALLATION - CONTINUED		
30. Left side frame (1), clamp (2) and spacer (3)	Four hoses (4, 5, 6, and 7)	Take off tags.
31. Adapter (8)	New packing (9)	Place in position.
32. Loader bucket cylinder (10)	Adapter (8) with assembled packing (9)	a. Unplug cylinder (10). b. Screw in and tighten using 1-inch open-end wrench.
33. Adapter (8)	Oil line (11)	a. Take off tag. b. Screw in and tighten using 7/8-inch and 1-inch open-end wrenches.
34. Loader bucket cylinder (10) and two oil lines (11 and 12)	Two clamps (13 and 14)	a. Place in same positions noted during removal. b. Using 1/4-inch flat-tip screwdriver, tighten.
35. Oil line(11)	Hose(15)	a. Take off tag. b. Screw in and tighten using 7/8-inch and 1-inch open-end wrenches.
36. Loader backhoe	Hydraulic oil filter	Install (page 2-1698).
37.	Transmission	Check fluid level and add proper amount and grade (TM 5-2420-22-10).
38.	Engine	Start and run at high idle (TM 5-2420-222-10).
39. Loader control		a. Operate loader bucket (TM 5-2420-22-10) and check for leaks. b. If leaking at any connection, tighten using 7/8-inch and two 1-inch open-end wrenches. c. If leaking does not stop, shut down engine (TM 5-2420-222-10) and replace leaking connection packing, fitting, hose, or oil line as outlined in this task. d. If found leaking, repeat 37 thru 39.

LOADER CONTROL VALVE-TO-LOADER BUCKET CYLINDER HEAD END OIL LINES - CONTINUED

LOCATION	ITEM	ACTION	REMARKS
----------	------	--------	---------

40.

Engine

If still running, shut down
(TM 5-2420-222-10).

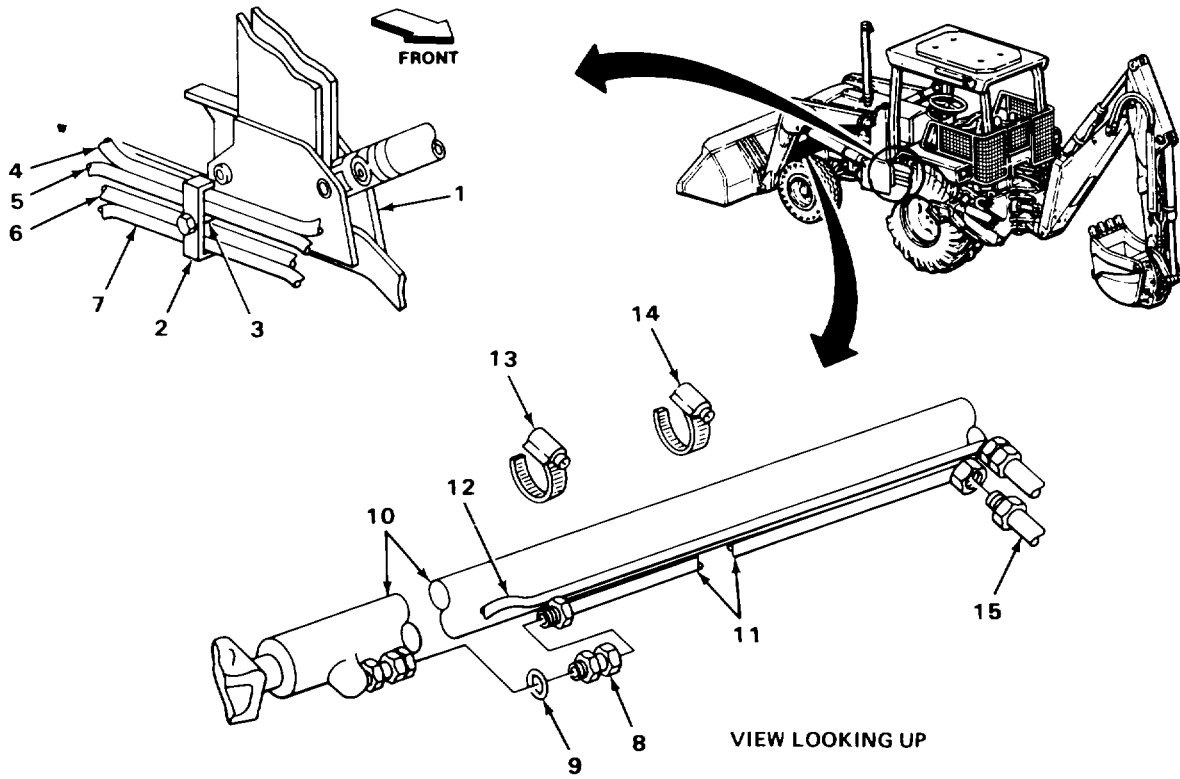

NOTE

FOLLOW-ON MAINTENANCE: Install right platform (page 2-1079).

TASK ENDS HERE

LOADER CONTROL VALVE-TO-LOADER BUCKET CYLINDER ROD END OIL LINES

This task covers:

- | | |
|---|--|
| <ul style="list-style-type: none"> a Removal (page 2-1670) b Cleaning (page 2-1674) | <ul style="list-style-type: none"> c Inspection/Replacement (page 2-1674) d Installation (page 2-1674) |
|---|--|

INITIAL SETUP

Tools

- Handle, ratchet, 3/8-inch drive
- Knife, pocket
- Screwdriver, flat-tip, 1/4-inch
- Socket, 3/8-inch drive, 9/16-inch
- Wrench, open-end, 7/8-inch
- Wrench, open-end, 1-inch
(two required)
- Wrench, open-end, 1 1/16-inch
- Wrench, open-end, 1 1/4-inch

Materials/Parts

- Detergent, GP (item 7, Appendix C)
- Lockwasher, clamp screw
- Packing, pipe nipple
- Packing, tee
- Rags, wiping (item 21, Appendix C)

Materials/Parts - Continued

- Solvent, drycleaning (item 28, Appendix C)
- Tags, marking (item 30, Appendix C)

Personnel Required

One

Equipment Condition

1. Hydraulic system pressure released (page 2-1191)
2. Right platform removed (page 2-1079)

LOCATION	ITEM	ACTION	REMARKS
----------	------	--------	---------

NOTE

Both loader control valve-to-loader bucket cylinder rod end oil lines are maintained the same way except as noted. Left oil line is shown. Repeat procedures as needed for right oil line.

REMOVAL

WARNING

Do not attempt to disconnect hydraulic lines and fittings while engine is running or before hydraulic system pressure has been released. When engine is running, hydraulic system is under pressure. Hydraulic system pressure should be 0 psi (0 kPa) before lines are disconnected. A line or fitting disconnected under pressure will blow off with a lot of force and could cause serious injury to personnel.

Be careful when draining hot fluids. Wear gloves to protect your hands from hot parts and fluids or severe burns could result.

LOADER CONTROL VALVE-TO-LOADER BUCKET CYLINDER ROD END OIL LINES - CONTINUED

LOCATION	ITEM	ACTION	REMARKS
1. Oil line (1)	Hose (2)	a. Place drain pan underneath. b. Using 7/8-inch and 1-inch open-end wrenches, unscrew and take out. c. Tag (page 2-137).	
2. Loader bucket cylinder (3) and two oil lines (1 and 4)	Two clamps (5 and 6)	a. Note relative position for proper placement during installation. b. Using 1/4-inch flat-tip screwdriver, unscrew and take off.	
3. Adapter (7)	Oil line (1)	a. Place drain pan underneath. b. Using 7/8-inch and 1-inch open-end wrenches, unscrew and take out. c. Tag (page 2-137).	
4. Loader bucket cylinder (3)	Adapter (7) with assembled packing (8)	a. Using 1-inch open-end wrench, unscrew and take out. b. Plug cylinder (1) (page 2-137).	
5. Adapter (7)	Packing (8)	a. Using pocket knife, take off. b. Get rid of.	

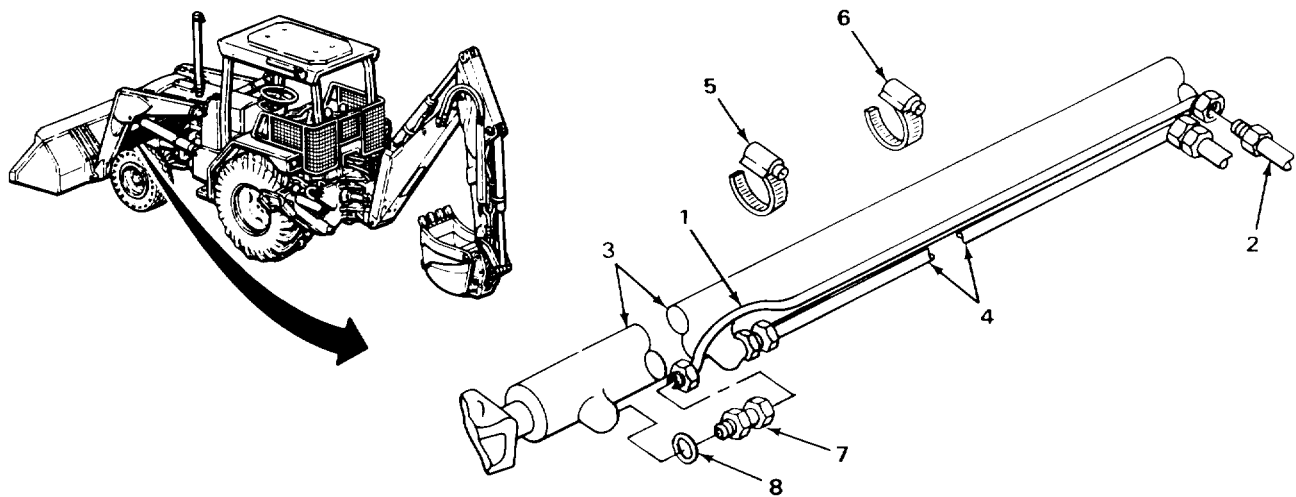

LOADER CONTROL VALVE-TO-LOADER BUCKET CYLINDER ROD END OIL LINES - CONTINUED

LOCATION	ITEM	ACTION	REMARKS
REMOVAL - CONTINUED			
NOTE			
If removing loader control valve-to-right loader bucket cylinder oil line, skip steps 6 thru 8.			
6. Left side frame (4), clamp (5), and spacer (6)	Four hoses (7, 8, 9, and 10)		Tag (page 2-137).
7. Screw (11) and lockwasher (12) and take out.		<ul style="list-style-type: none"> a. Using 9/16-inch, 3/8-inch drive socket and ratchet handle, unscrew b. Get rid of lockwasher (12). 	
8. Left side frame (4)	Clamp (5), spacer (6), and four hoses (7, 8, 9, and 10)	<ul style="list-style-type: none"> a. Note relative position of hoses (7, 8, 9, and 10) for placement during installation. b. Take off. 	
9. Tee (13)	Two hoses (7 and 14)	<ul style="list-style-type: none"> a. Place drain pan underneath. b. Using 7/8-inch and 1-inch open-end wrenches, unscrew and take out. c. Cap hose (7 or 14) (page 2-137) if removed for access. d. Tag (page 2-137). 	
10. Elbow (15)	Oil line (16)	Using 1-inch and 1 1/16-inch open-end wrenches, loosen.	
11. Special connector (17)	Oil line (18)	<ul style="list-style-type: none"> a. Place drain pan underneath. b. Using 1-inch and 1 1/4-inch open-end wrenches, unscrew and take out. c. Plug (page 2-137). d. Cap connector (1) (page 2-137). e. Tag (page 2-137). 	
12. Loader control valve (19) and tee (13)	Nut (20)	Using two 1-inch open-end wrenches, loosen.	
13. Loader bucket valve (19)	Tee (13) with assembled parts	<ul style="list-style-type: none"> a. Note relative position for proper placement during installation. b. Using 1-inch open-end wrench, unscrew and take out. c. Plug valve (3) (page 2-137). d. Get rid of drained fluid (page 2-137). 	

LOADER CONTROL VALVE-TO-LOADER BUCKET CYLINDER ROD END OIL LINES - CONTINUED

LOCATION	ITEM	ACTION	REMARKS
----------	------	--------	---------

14. Tee (13)

Packing (21)

- a. Using pocket knife, take off.
- b. Get rid of.

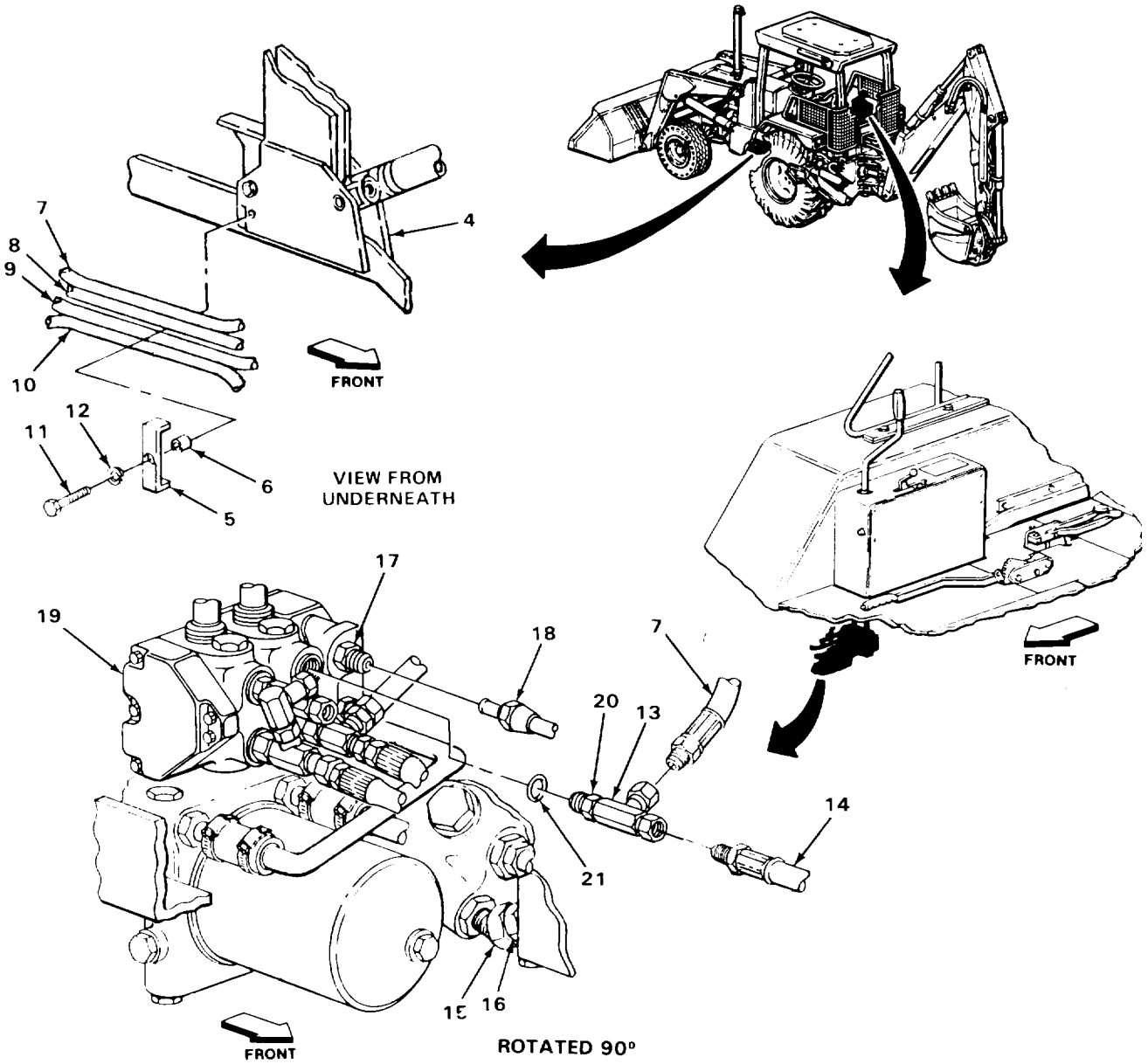

LOADER CONTROL VALVE-TO-LOADER BUCKET CYLINDER ROD END OIL LINES - CONTINUED

LOCATION	ITEM	ACTION	REMARKS
----------	------	--------	---------

CLEANING**NOTE**

For more information on how to clean parts, go to **General Maintenance Instructions (page 2-137)**.

- | | | | |
|-----|----------|---|--|
| 15. | Hose (1) | a. Using clean rags dampened in solution of detergent and water, wipe clean.
b. Rinse with clean water.
c. Using clean, dry rags, wipe dry. | |
|-----|----------|---|--|

WARNING

Drycleaning solvent P-D-680 is toxic and flammable. Wear protective goggles and gloves and use only in a well ventilated area. Avoid contact with skin, eyes, and clothes and don't breathe vapors. Do not use near open flame or excessive heat. The flashpoint is 1000F to 138°F (38° to 59°C). If you become dizzy while using cleaning solvent, get fresh air immediately and get medical aid. If contact with eyes is made, wash your eyes with water and get medical aid immediately.

- | | | | |
|-----|-----------------------|--|--|
| 16. | Oil line (2) | a. Using clean rags dampened in dry-cleaning solvent, wipe clean.
b. Using clean, dry rags, wipe dry. | |
| 17. | All other metal parts | a. Clean in drycleaning solvent.
b. Using clean, dry rags, wipe dry. | |

INSPECTION/REPLACEMENT**NOTE**

For more information on how to inspect parts, go to **General Maintenance Instructions (page 2-137)**.

Replace defective parts as needed.

- | | | | |
|-----|--------------------|--|--|
| 18. | Hose (1) | Look for cracks, breaks, cuts, and tears. | |
| 19. | All metal parts | Look for cracks and breaks and abnormal bends. | |
| 20. | All threaded parts | Look for damaged threads. | |

INSTALLATION

- | | | | |
|-------------|---------|-----------------------|--|
| 21. Tee (3) | Nut (4) | Screw on all the way. | |
|-------------|---------|-----------------------|--|

LOADER CONTROL VALVE-TO-LOADER BUCKET CYLINDER ROD END OIL LINES - CONTINUED

LOCATION	ITEM	ACTION REMARKS
22.	New packing (5)	Place in position.
23. Loader control valve (6)	Tee (3) with assembled parts	a. Unplug valve (6). b. Screw in and tighten to same relative position noted during assembly using 1-inch open-end wrench.
24. Loader control valve (6) and tee (3)	Nut (4)	Using two 1-inch open-end wrenches, tighten until seated against valve (6).

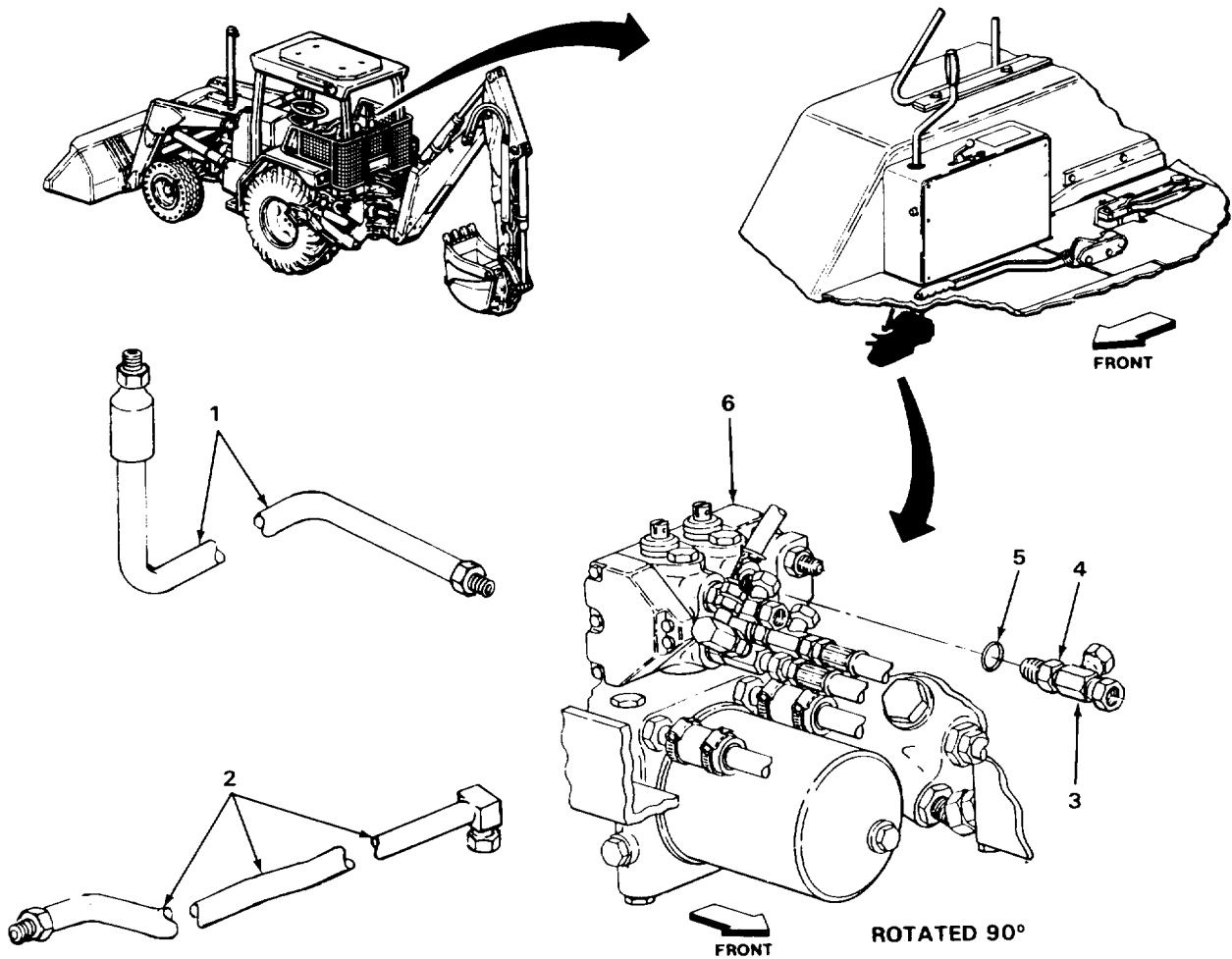

LOADER CONTROL VALVE-TO-LOADER BUCKET CYLINDER ROD END OIL LINES - CONTINUED

LOCATION	ITEM	ACTION REMARKS
INSTALLATION - CONTINUED		
25. Special connector (1)	Oil Line (2)	a. Uncap connector (7). b. Unplug. c. Take off tag. d. Screw on and tighten using 1-inch and 1 1/4-inch open-end wrenches.
26. Elbow (3)	Oil line (4)	Using 1-inch and 1 1/16-inch open-end wrenches, tighten.
27. Tee (5)	Two hoses (6 and 7)	a. Uncap hose (1 or 9) if removed for access. b. Take off tags. c. Screw in and tighten using 7/8-inch and 1-inch open-end wrenches.
NOTE		
If installing loader control valve-to-right loader bucket cylinder oil line, skip steps 28 thru 30.		
28. Left side frame (8)	Four hoses (9, 10, 11, and 12), clamp (13), and spacer (14)	Place in same relative position noted during removal.
29. Left side frame (1), clamp (13), and spacer (14)	Screw (15) and new lockwasher (16)	Screw in and tighten using 9/16-inch, 3/8-inch drive socket and ratchet handle.
30.	Four hoses (9, 10, 11, and 12)	Take off tags.
31. Adapter (17)	New packing (18)	Place in position.
32. Loader bucket	Adapter (17) cylinder (19)	a. Unplug cylinder (19). b. Screw in and tighten using 1-inch
33. Adapter (17)	Oil line (20)	a. Take off tag. b. Screw in and tighten using 7/8-inch open-end wrench.
34. Loader bucket cylinder (19), and two oil lines (20 and 21)	Two clamps (22 and 23)	a. Place in same relative position noted during removal. b. Using 1/4-inch flat-tip screwdriver, tighten.

LOADER CONTROL VALVE-TO-LOADER BUCKET CYLINDER ROD END OIL LINES - CONTINUED

LOCATION	ITEM	ACTION	REMARKS
----------	------	--------	---------

35. Oil line (20)

Hose (24)

- a. Take off tag.
- b. Screw in and tighten using 1/4-inch flat-tip screwdriver.

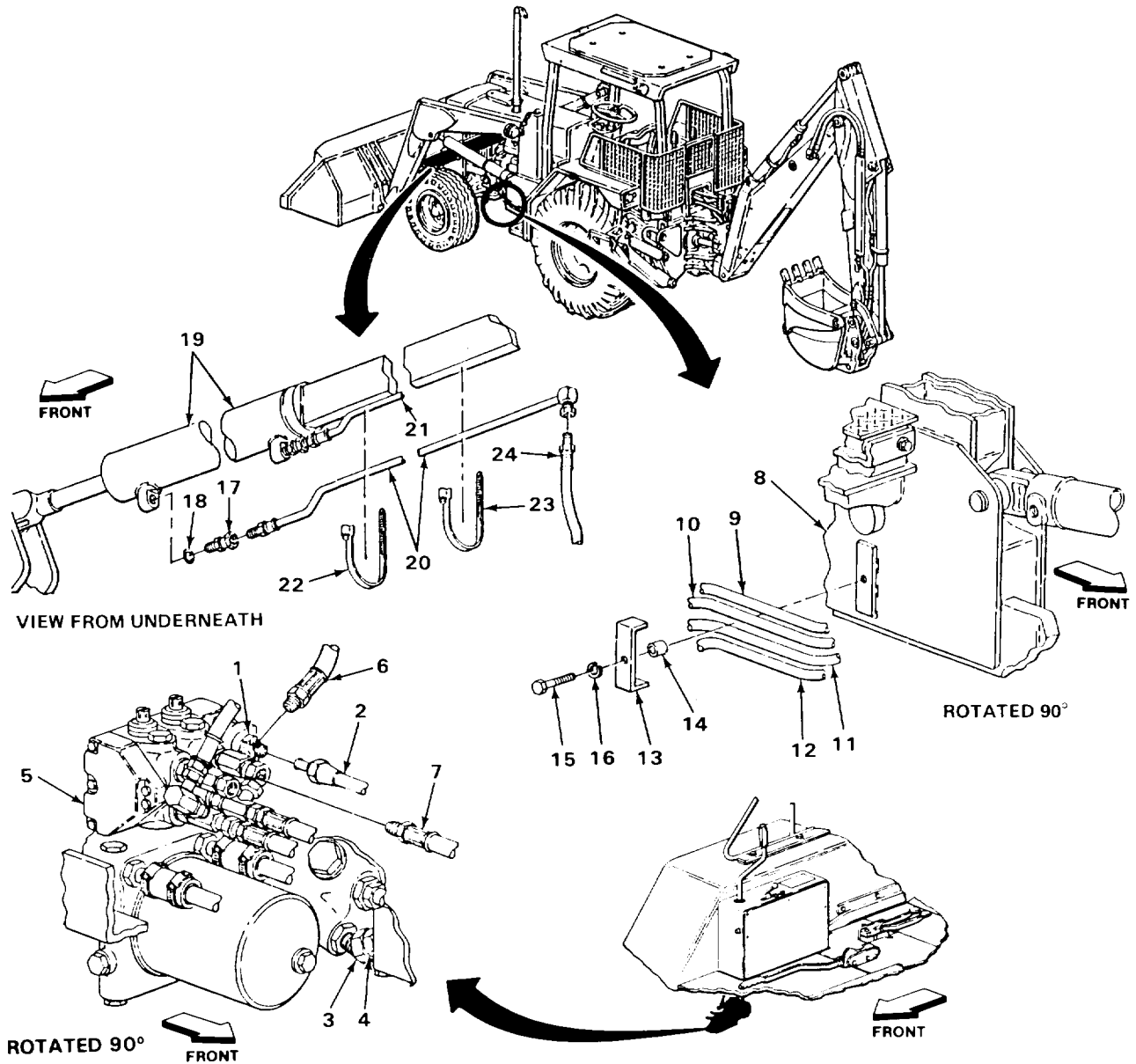

LOADER CONTROL VALVE-TO-LOADER BUCKET CYLINDER ROD END OIL LINES - CONTINUED

LOCATION	ITEM	ACTION	REMARKS
INSTALLATION - CONTINUED			
36	Loader backhoe	Transmission	Check fluid level and add proper amount and grade (TM 5-2420-222-10).
37	Engine		Start and run at high idle (TM 5-2420-222-10).
38	Loader control valve-to-loader bucket cylinder rod end oil line		<ul style="list-style-type: none"> a Operate jaw loader bucket (TM 5-2420-222-10) and check for leaks. b If leaking at any connection, tighten using 7/16-inch, two 1-inch, 1 1/16-inch, and 1 1/4-inch open-end wrenches. c If leaking does not stop, shut down engine (TM 5-2420-222-10) and replace leaking connection, packing, or oil line as outlined in this task. d If found leaking, repeat steps 36 thru 38.
39	Engine		If still running, shut down (TM 5-2420-222-10).

NOTE

FOLLOW-ON MAINTENANCE: Install right platform (page 2-1079).

TASK ENDS HERE

LOADER CONTROL VALVE-TO-LOADER BOOM CYLINDER HEAD END OIL LINES

This task covers:

- a Removal (page 2-1680)
 - b Cleaning (page 2-1682)
 - c Inspection/Replacement (page 2-1684)
 - d Installation (page 2-1684)
-

INITIAL SETUP

Tools

- Handle, ratchet, 3/8-inch drive
- Knife, pocket
- Pan, drain
- Screwdriver, flat-tip, 1/4-inch
- Socket, 3/8-inch drive, 9/16-inch
- Wrench, open-end, 7/8-inch
- Wrench, open-end, 1-inch (two required)

Materials/Parts

- Detergent, GP (item 7, Appendix C)
- Lockwasher, clamp
- Packing, long tee
- Packing, union

Materials/Parts - Continued

- Rags, wiping (item 21, Appendix C)
- Solvent, drycleaning (item 28, Appendix C)
- Tags, marking (item 30, Appendix C)

Personnel Required

One

Equipment Condition

- 1 Hydraulic pressure released (page 2-1191)
 - 2 Right platform removed (page 2-1079)
-

LOCATION	ITEM	ACTION	REMARKS
----------	------	--------	---------

NOTE

Both loader control valve-to-loader boom cylinder oil lines are maintained the same way except as noted. Left oil line is shown. Repeat procedures as needed for right oil line.

LOADER CONTROL VALVE-TO-LOADER BOOM CYLINDER HEAD END OIL LINES - CONTINUED

LOCATION	ITEM	ACTION	REMARKS
REMOVAL			
WARNING			
<p>Do not attempt to disconnect hydraulic lines and fittings while engine is running or before hydraulic system pressure has been released. When engine is running, hydraulic system is under pressure. Hydraulic system pressure should be 0 psi (0 kPa) before lines are disconnected. A line or fitting disconnected under pressure will blow off with a lot of force and could cause serious injury to personnel.</p> <p>Be careful when draining hot fluids. Wear gloves to protect your hands from hot parts and fluids or severe burns could result.</p>			
1	Union (1)	Hose (2)	<ul style="list-style-type: none"> a Place drain pan underneath. b Using 7/8-inch and 1-inch open-end wrenches, unscrew and take out. c Tag (page 2-137).
2	Loader boom cylinder (3) and union (1)	Nut (4) loosen.	Using two 1-inch open-end wrenches,
3	Loader boom cylinder (3)	Union (1) with assembled parts	<ul style="list-style-type: none"> a Note relative position for proper placement during installation. b Using 1-inch open-end wrench, unscrew and take out. c Plug cylinder (3) (page 2-137).
4	Union (1)	Packing (5)	<ul style="list-style-type: none"> a Using pocket knife, take out. b Get rid of.
NOTE			
If removing loader control valve to left loader boom cylinder oil line, skip step 5.			
5	Hoses (6 and 7)	Clamp (8)	<ul style="list-style-type: none"> a Note relative position for proper placement during installation. b Using 1/4-inch flat-tip screwdriver, loosen and take off.

LOADER CONTROL VALVE-TO-LOADER BOOM CYLINDER HEAD END OIL LINES - CONTINUED

LOCATION	ITEM	ACTION	REMARKS
----------	------	--------	---------

NOTE

If removing loader control valve-to-right loader boom cylinder oil line, skip step 6 thru 8.

Only loader backhoes with Serial Numbers 319995 thru 342573 are equipped with spacer between clamp and side frame.

6	Left side frame (9), clamp (10), and spacer (11), if present	Four hoses (2,12,13, and 14)	Tag (page 2-137).
7	Screw (15) and lockwasher (16)	<ul style="list-style-type: none"> a Using 9/16-inch, 3/8-inch drive socket and ratchet handle, unscrew and take out. b Get rid of lockwasher (16). 	

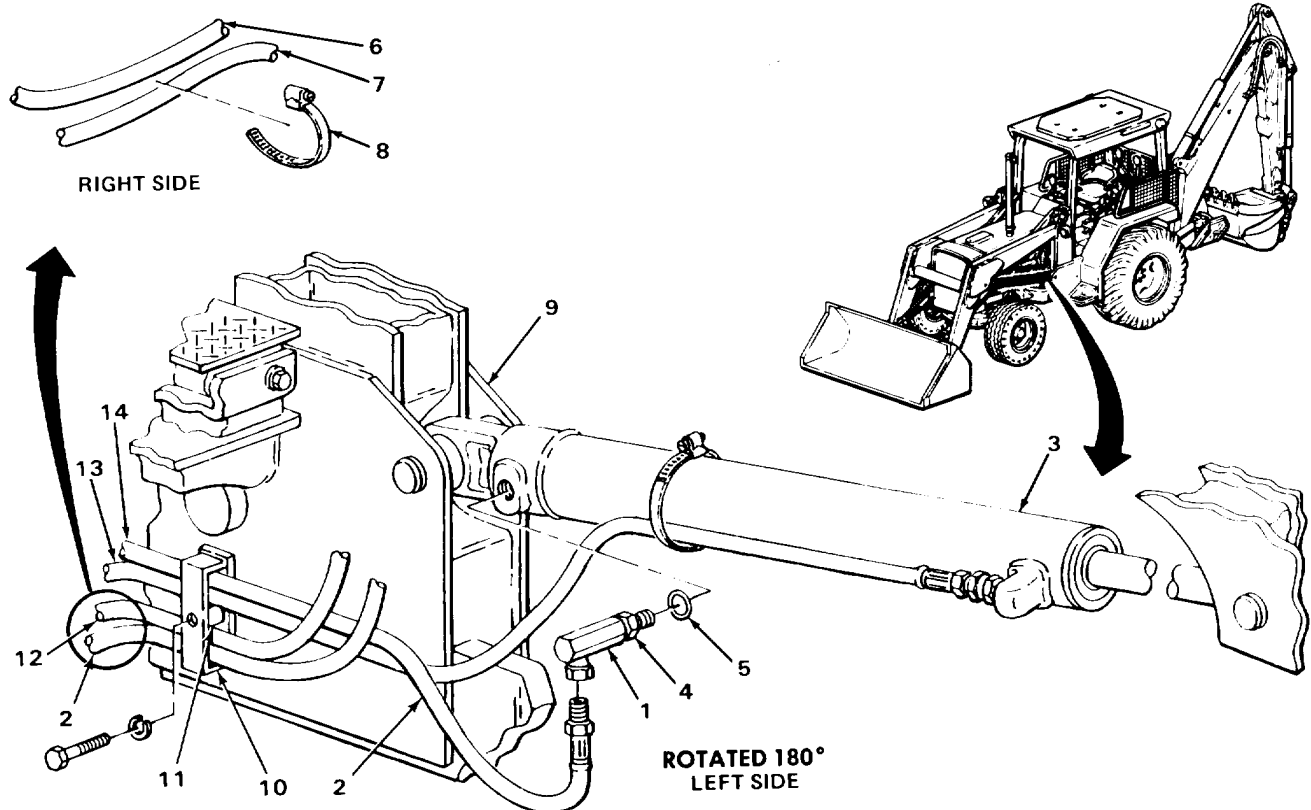

TA243535

LOADER CONTROL VALVE-TO-LOADER BOOM CYLINDER HEAD END OIL LINES - CONTINUED

LOCATION	ITEM	ACTION REMARKS
REMOVAL - CONTINUED		
8 Left side frame (1)	Clamp (2), spacer (3), if present, and four hoses (4, 5, 6, and 7)	<ul style="list-style-type: none"> a Note relative position of hoses (4, 5, 6, and 7) for proper placement during installation. b Take off.
9 Long tee (8)	Two hoses (4 and 9)	<ul style="list-style-type: none"> a Place drain pan underneath. b Using 7/8-inch and 1-inch open-end wrenches, unscrew and take out. c Cap hose (9) (page 2-137). d Tag (page 2-137).
10 Loader backhoe	Hose (4)	Note routing for proper placement during installation, take out.
11 Loader control valve (10) and long tee (8)	Nut (11)	Using two 1-inch open-end wrenches, loosen.
12 Loader control valve (10)	Long tee (8) with assembled parts	<ul style="list-style-type: none"> a Place drain pan underneath. b Note relative position for proper placement during installation. c Using 1-inch open-end wrench, unscrew and take out. d Plug control valve (10) (page 2-137). e Get rid of drained fluid (page 2-137).
13 Long tee (8)	Packing (12)	<ul style="list-style-type: none"> a Using pocket knife, take off. b Get rid of.

CLEANING**NOTE**

For more information on how to clean parts, go to General Maintenance Instructions (page 2-137).

14	Hose (4)	<ul style="list-style-type: none"> a Using clean rags dampened with solution of detergent and water, wipe clean. b Rinse with clean water. c Using clean, dry rags, wipe dry.
----	----------	--

LOADER CONTROL VALVE-TO-LOADER BOOM CYLINDER HEAD END OIL LINES - CONTINUED

LOCATION	ITEM	ACTION	REMARKS
----------	------	--------	---------

WARNING

Drycleaning solvent P-D-680 is toxic and flammable. Wear protective goggles and gloves and use only in a well ventilated area. Avoid contact with skin, eyes, and clothes and don't breathe vapors. Do not use near open flame or excessive heat. The flashpoint is 100°F to 138°F (38° to 59°C). If you become dizzy while using cleaning solvent, get fresh air immediately and get medical aid. If contact with eyes is made, wash your eyes with water and get medical aid immediately.

15	All metal parts	a Clean in drycleaning solvent. b Using clean, dry rags, wipe dry.	
----	-----------------	---	--

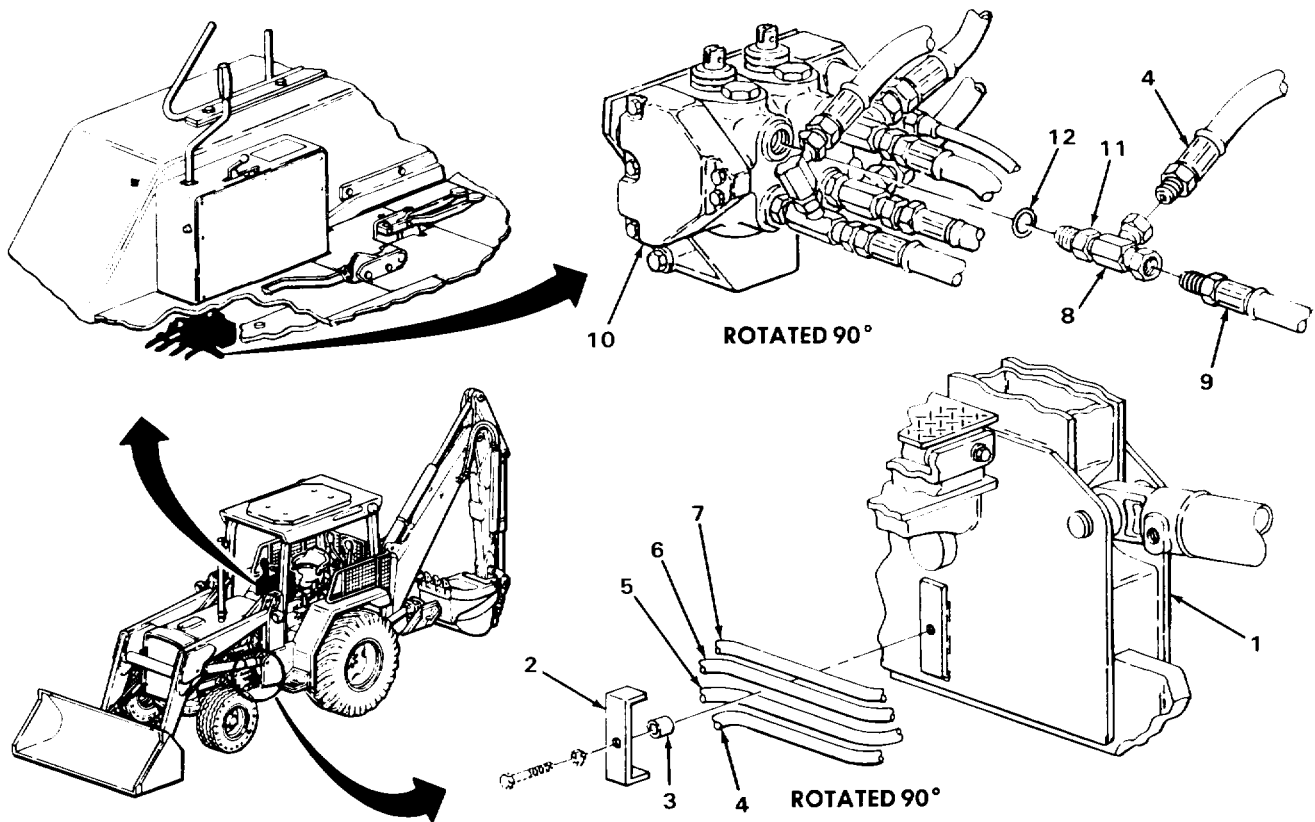

LOADER CONTROL VALVE-TO-LOADER BOOM CYLINDER HEAD END OIL LINES - CONTINUED

LOCATION	ITEM	ACTION	REMARKS
INSPECTION/REPLACEMENT			
NOTE			
For more information on how to inspect parts, go to General Maintenance Instructions (page 2-137).			
Replace defective parts as needed.			
16	Hose (1)		Look for cuts, cracks, and breaks.
17	All metal parts bends.		Look for cracks, breaks, and abnormal
18	All threaded parts		Look for damaged threads.
INSTALLATION			
19	Long tee (2)	Nut (3)	Screw on all the way.
20	New packing (4)	Place in position.	
21	Loader control valve (5)	Long tee (2) with assembled packing (4)	a Unplug control valve (5). b Screw into same relative position as noted during removal using 1-inch open-end wrench.
22	Loader control valve (5) and long tee (2)	Nut (3)	Using two 1-inch open-end wrenches, tighten until seated against loader control valve (5).
23	Loader backhoe	Hose (1) noted during removal.	Route into same relative position as
24	Long tee (2) (1 and 6)	Two hoses	a Unplug hose (6). b Take off tag. c Screw in and tighten using 7/8-inch and 1-inch open-end wrenches.

LOADER CONTROL VALVE-TO-LOADER BOOM CYLINDER HEAD END OIL LINES - CONTINUED

LOCATION	ITEM	ACTION	REMARKS
----------	------	--------	---------

NOTE

If installing loader control valve to right loader boom cylinder oil line, skip steps 25 thru 27.

- | | | |
|--|---|---|
| 25. Left side frame (7) | Clamp (8), spacer (9), if present, and four hoses (1, 10, 11, and 12) | Place into position as noted during removal. |
| 26. Left side frame (7), clamp (8), and spacer (9), if present | Screw (13) and lockwasher (14) | Screw in and tighten using 9/16-inch, 3/8-inch drive socket and ratchet handle. |
| 27. | Four hoses (1, 10, 11, and 12) | Take off tags. |

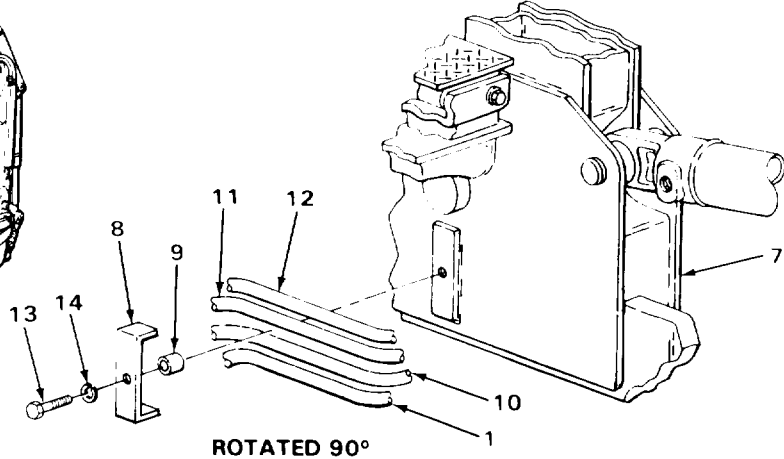
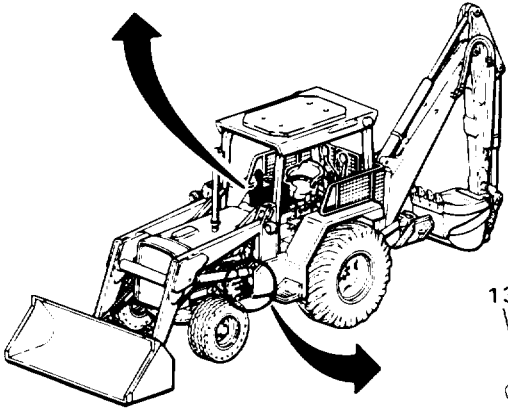
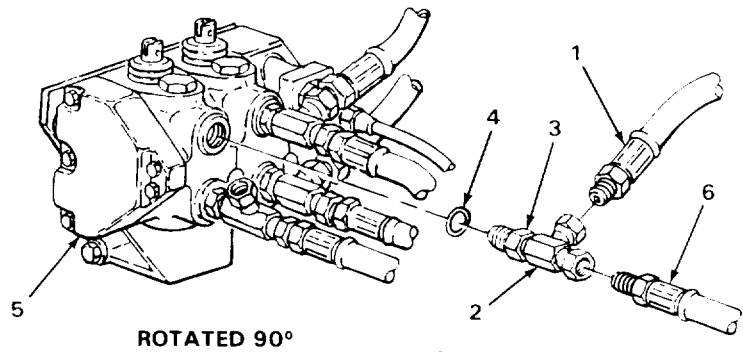
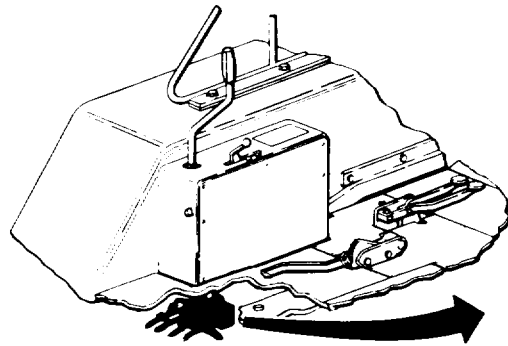

LOADER CONTROL VALVE-TO-LOADER BOOM CYLINDER HEAD END OIL LINES - CONTINUED

LOCATION	ITEM	ACTION	REMARKS
INSTALLATION - CONTINUED			
NOTE			
If installing loader control valve to left loader boom cylinder oil line, skip step 28.			
28. Hoses (1 and 2)	Clamp (3)	a Place into position as noted during removal. b Using 1/4-inch flat-tip screwdriver, tighten.	
29. Union (4)	Nut (5)	Screw on all the way.	
30. New packing (6)	Place into position.		
31. Loader boom cylinder (7)	Union (4) with assembled parts	a Unplug cylinder(7). b Screw in to same relative position as noted during removal using 1-inch open-end wrench.	
32. Loader boom cylinder (7) and union (4)	Nut (5) tighten until seated against loader boom cylinder.	Using two 1-inch open-end wrenches,	
33. Union (4)	Hose (8)	a Take off tag. b Screw in and tighten using 7/8-inch and 1-inch open-end wrenches.	
34. Loader backhoe	Transmission	Check fluid level and add proper amount and grade (TM 5-2420-222-10).	
35. Engine		Start and run at high idle (TM 5-2420-222-10).	
36.	Loader control valve-to-boom cylinder head end oil lines	a. Operate lift arms (TM 5-2420-222-10) and check for leaks. b. If leaking at any connection, tighten using 7/8-inch and two 1-inch open-end wrenches. c. If leaking does not stop, shut down engine (TM 5-2420-222-10) and replace leaking connection packing, fitting, or line as outlined in this task. d. If found leaking, repeat steps 34 thru 36.	

LOADER CONTROL VALVE-TO-LOADER BOOM CYLINDER HEAD END OIL LINES - CONTINUED

LOCATION	ITEM	ACTION	REMARKS
----------	------	--------	---------

37.

Engine

If still running, shut down
(TM 5-2420-222-10).

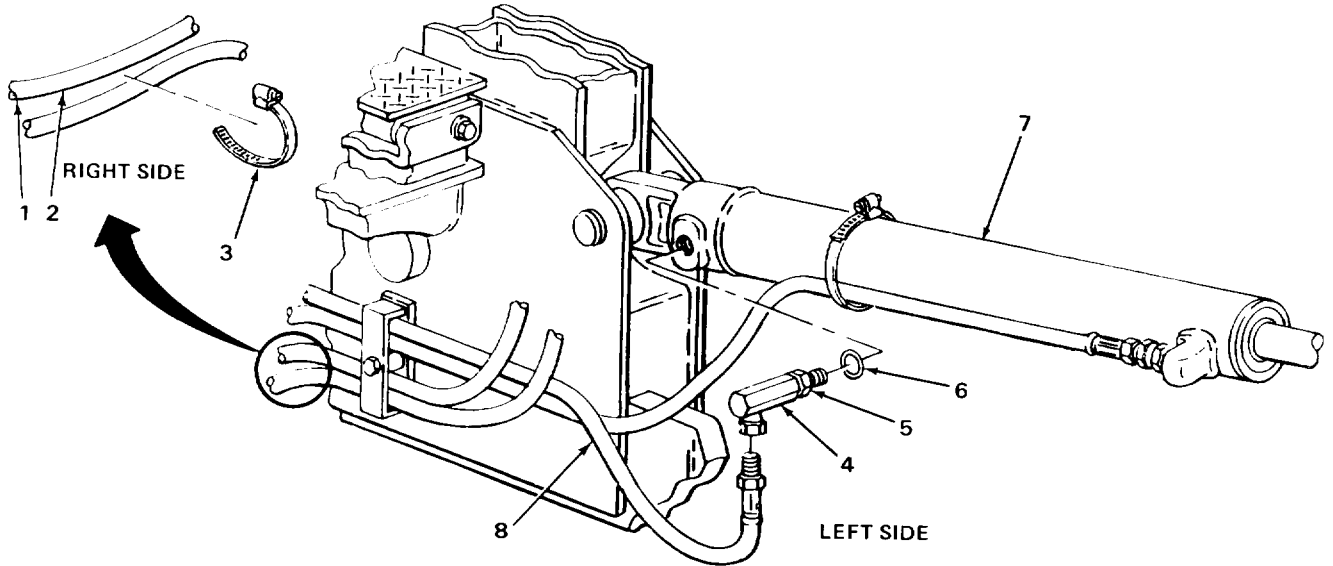

NOTE

FOLLOW-ON MAINTENANCE: Install right platform (page 2-1079).

TASK ENDS HERE

LOADER CONTROL VALVE-TO-LOADER BOOM CYLINDER ROD END OIL LINES

This task covers:

- a Removal (page 2-1688)
- b Cleaning (page 2-1692)
- c Inspection/Replacement (page 2-1692)
- d Installation (page 2-1693)

INITIAL SETUP

Tools

- Handle, ratchet, 3/8-inch drive
- Knife, pocket
- Pan, drain
- Screwdriver, flat-tip, 114-inch
- Socket, 3/8-inch drive, 9/16-inch
- Wrench, open-end, 7/8-inch
- Wrench, open-end, 1-inch (two required)

Materials/Parts

- Detergent, GP (item 7, Appendix C)
- Lockwasher, clamp
- Packing, adapter
- Packing, tee

Materials/Parts - Continued

- Rags, wiping (item 21, Appendix C)
- Solvent, drycleaning (item 28, Appendix C)
- Tags, marking (item 30, Appendix C)

Personnel Required

One

Equipment Condition

- 1 Hydraulic pressure released (page 2-1191)
- 2 Right platform removed (page 2-1079)

LOCATION	ITEM	ACTION	REMARKS
----------	------	--------	---------

NOTE

Both loader control valve-to-loader boom cylinder oil lines are maintained the same way except as noted. Left oil line is shown. Repeat procedure for right oil line.

REMOVAL

WARNING

Do not attempt to disconnect hydraulic lines and fittings while engine is running or before hydraulic system pressure has been released. When engine is running, hydraulic system is under pressure. Hydraulic system pressure should be 0 psi (0 kPa) before lines are disconnected. A line or fitting disconnected under pressure will blow off with a lot of force and could cause serious injury to personnel.

Be careful when draining hot fluids. Wear gloves to protect your hands from hot parts and fluids or severe burns could result.

LOADER CONTROL VALVE-TO-LOADER BOOM CYLINDER ROD END OIL LINES- CONTINUED

LOCATION	ITEM	ACTION	REMARKS
1. Adapter (1)	Hose (2)	a. Place drain pan underneath. b. Using 7/8-inch and 1-inch open-end wrenches, unscrew and take out. c. Tag (page 2-137).	
2. Hose (2) and loader boom cylinder (3)	Clamp (4)	a. Note relative position for proper placement during installation. b. Using 1/4-inch flat-tip screwdriver, loosen and take off.	
3. Loader boom cylinder (3)	Adapter (1) with assembled packing (5)	a. Place drain pan underneath. b. Using 1-inch open-end wrench, unscrew and take out.	
4. Adapter (1)	Packing (5)	a. Using pocket knife, take off. b. Get rid of.	

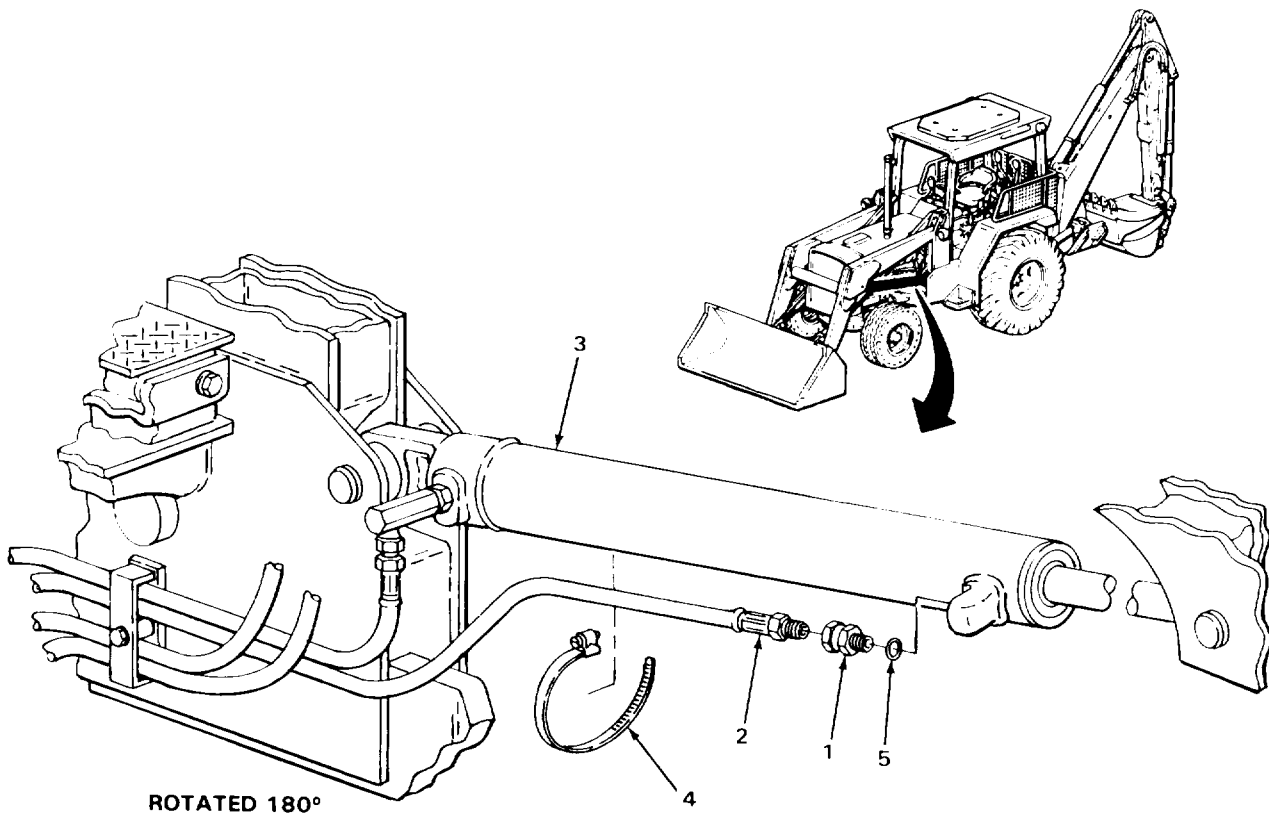

LOADER CONTROL VALVE-TO-LOADER BOOM CYLINDER ROD END OIL LINES - CONTINUED

LOCATION	ITEM	ACTION	REMARKS
REMOVAL - CONTINUED			
NOTE			
If removing loader control valve-to-left loader boom cylinder rod end oil line, skip step 5.			
5. Two hoses (1 and 2)	Clamp (3)	a. Note relative position for proper placement during installation. b. Using 1/4-inch flat-tip screwdriver, loosen and take off.	
NOTE			
If removing loader control valve-to-right loader boom cylinder rod end oil line, skip steps 6 thru 8.			
Only loader backhoes with Serial Numbers 319995 thru 342573 are equipped with spacer between clamp and hoses.			
6. Left side frame (4), clamp (5), and spacer (6), if present	Four hoses (7, 8, 9, and 10)	Tag Page 2-137).	
7.	Screw (11) and lockwasher (12)	a. Using 9/16-inch, 3/8-inch drive socket and ratchet handle, unscrew and take out. b. Get rid of lockwasher (12).	
8. Left side frame (4)	Clamp (5), spacer (6), if present, and four hoses (7, 8, 9, and 10)	Note relative position to hoses (7, 8, 9, and 10) for proper placement during installation.	
9. Tee (13)	Hose (14)	a. Place drain pan underneath. b. Using 7/8-inch and 1-inch open-end wrenches, unscrew and take off.	
10. Union (15)	Hose (7)	Using 7/8-inch and 1-inch open-end wrenches, unscrew and take off.	
11 Loader backhoe	Hose (7)	Note routing for proper placement during installation, take out.	

LOADER CONTROL VALVE-TO-LOADER BOOM CYLINDER ROD END OIL LINES- CONTINUED

LOCATION	ITEM	ACTION	REMARKS
----------	------	--------	---------

- | | | | |
|--|------------|---|--|
| 12. Tee (13) | Union (15) | Using two 1-inch open-end wrenches, unscrew and take off. | |
| 13. Loader control valve (16) and tee (13) | Nut (17) | Using two 1-inch open end wrenches, loosen. | |

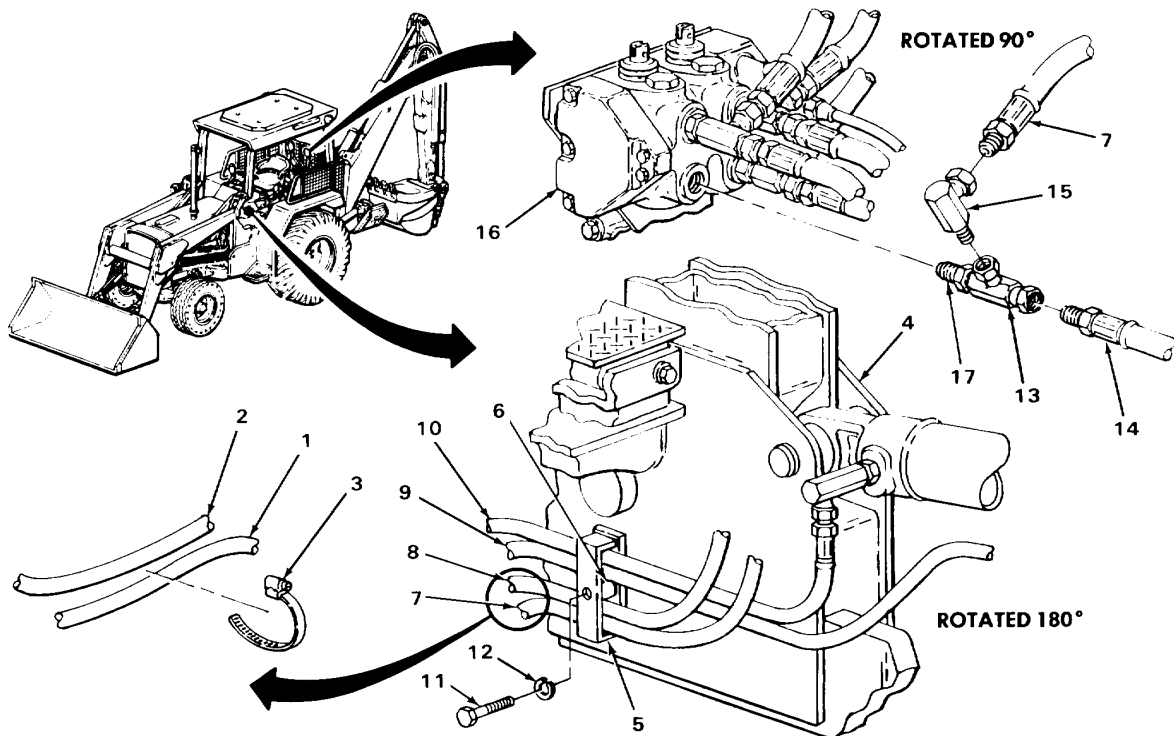

TA243540

LOADER CONTROL VALVE-TO-LOADER BOOM CYLINDER ROD END OIL LINES- CONTINUED

LOCATION	ITEM	ACTION	REMARKS
REMOVAL - CONTINUED			
14. Loader control valve (1)	Tee (2) with assembled parts	a. Note relative position for proper placement during installation. b. Using 1-inch open-end wrench, unscrew and take off. c. Plug control valve (1) (page 2-137). d. Get rid of drained fluid (page 2-137).	
15. Tee (2)	Packing (3)	a. Using pocket knife, take off. b. Get rid of.	
CLEANING			
NOTE			
For more information on how to clean parts, go to General Maintenance Instructions (page 2-137).			
16	Hose (4)	a. Using clean rags dampened with solution of detergent and water, wipe clean. b. Rinse with clean water. c. Using clean, dry rags, wipe dry.	
WARNING			
Drycleaning solvent P-D-680 is toxic and flammable. Wear protective goggles and gloves and use only in a well ventilated area. Avoid contact with skin, eyes, and clothes and don't breathe vapors. Do not use near open flame or excessive heat. The flashpoint is 100°F to 138°F (38° to 59°C). If you become dizzy while using cleaning solvent, get fresh air immediately and get medical aid. If contact with eyes is made, wash your eyes with water and get medical aid immediately.			
17.	All metal parts	a. Clean in drycleaning solvent. b. Using clean, dry rags, wipe dry.	

INSPECTION/REPLACEMENT**NOTE**

For more information on how to inspect parts, go to General Maintenance Instructions (page 2-137).

Replace defective parts as needed.

LOADER CONTROL VALVE-TO-LOADER BOOM CYLINDER ROD END OIL LINES - CONTINUED

LOCATION	ITEM	ACTION REMARKS
18.	Hose (4)	Look for cuts, cracks, and breaks.
19.	All metal parts	Look for cracks, breaks, and abnormal bends.
20.	All threaded parts	Look for damaged threads.
INSTALLATION		
21. Tee (2)	Nut (5)	Screw on all the way.
22.	New packing (3)	Place in position.
23. Loader control valve (1)	Tee (2) with assembled packing (3)	a. Unplug control valve (1). b. Screw in and tighten to same relative position as noted during removal using 1-inch open-end wrench.

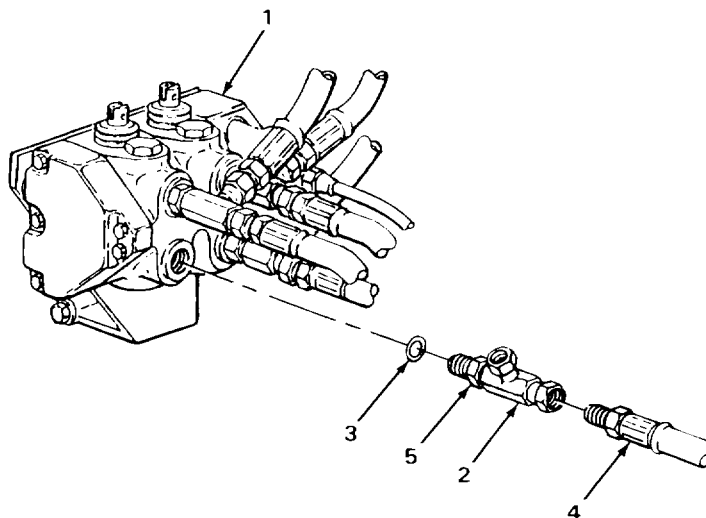

TA243541

LOADER CONTROL VALVE-TO-LOADER BOOM CYLINDER ROD END OIL LINES - CONTINUED

LOCATION	ITEM	ACTION	REMARKS
INSTALLATION - CONTINUED			
24. Loader control valve (1) and tee (2)	Nut (3)	Using two 1-inch open-end wrenches, tighten until seated against control valve (1).	
25. Tee (2)	Union (4)	Screw in and tighten using 7/8-inch and 1-inch open-end wrenches.	
26. Loader backhoe	Hose (5)	Route into position as noted during removal.	
27. Union (4)	Hose (5)	Screw on and tighten using 7/8-inch and 1-inch open-end wrenches.	
28. Tee (2)	Hose (6)	Screw on and tighten using 7/8-inch and 1-inch open-end wrenches.	

NOTE

If installing loader control valve-to-right loader boom cylinder rod end oil line, skip steps 29 thru 31.

Only loader backhoes with Serial Numbers 319995 thru 342573 are equipped with spacer between clamp and hoses.

29. Left side frame (7)	Clamp (8), spacer (9), if present, and four hoses (5, 10, 11, and 12)	Place into position as noted during removal.	
30. Left side frame (7), clamp (8), and spacer (9)	Screw (13) and new lockwasher (14)	Screw in and tighten using 9/16-inch, 3/8-inch drive socket and ratchet handle.	
31.	Four hoses (5, 10, 11 and 12)	Take off tags.	

LOADER CONTROL VALVE-TO-LOADER BOOM CYLINDER ROD END OIL LINES - CONTINUED

LOCATION	ITEM	ACTION	REMARKS
----------	------	--------	---------

NOTE

If installing loader control valve-to-left loader boom cylinder rod end oil line, skip step 32.

- | | | |
|-------------------------------|--|---|
| 32. Two hoses (15 and 16) | Clamp (17) | Screw on and tighten to same relative position as noted during removal using 1/4-inch flat-tip screwdriver. |
| 33. Adapter (18) | New packing (19) | Place in position. |
| 34. Loader boom cylinder (20) | Adapter (18) with assembled packing (19) | Screw on and tighten using 1-inch open-end wrench. |

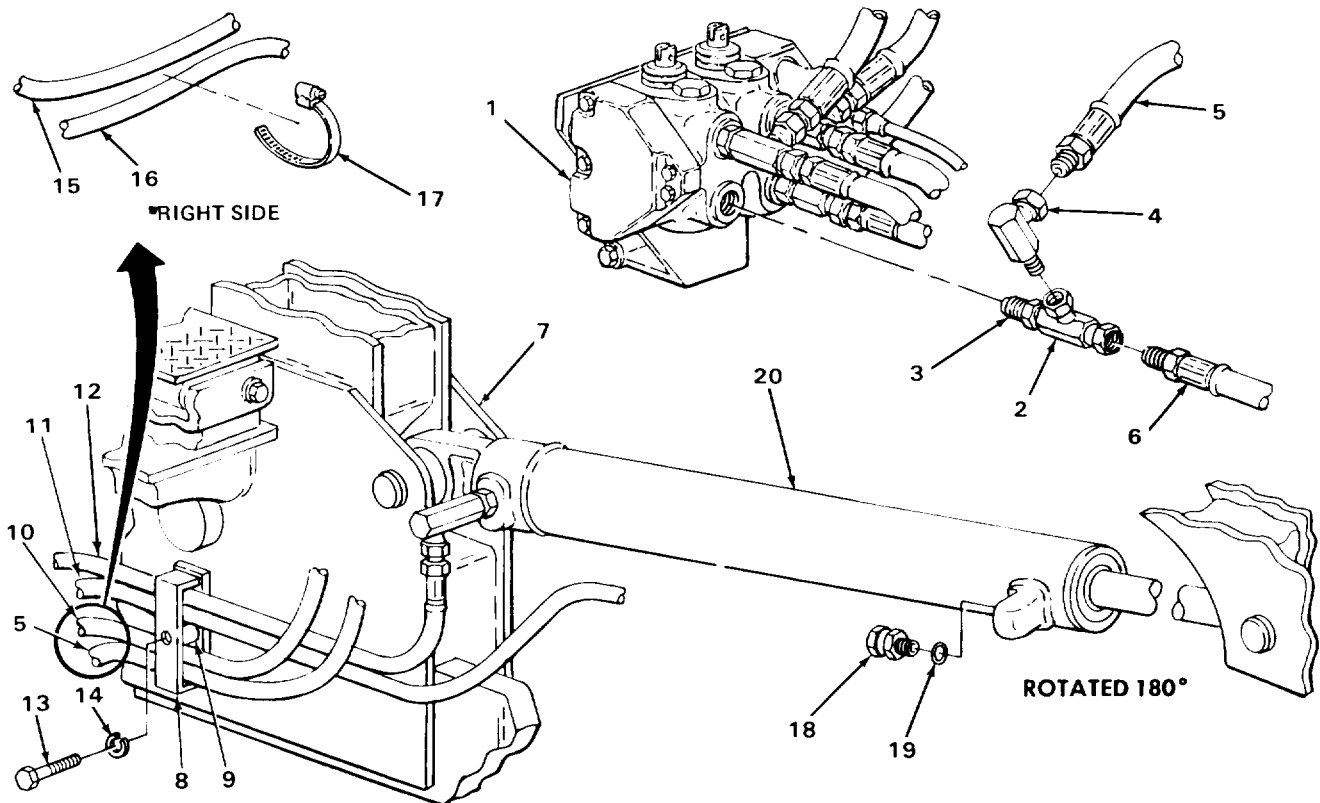

TA243542

LOADER CONTROL VALVE-TO-LOADER BOOM CYLINDER ROD END OIL LINES - CONTINUED

LOCATION	ITEM	ACTION REMARKS
35. Adapter (1)	Hose (2)	a. Take off tag. b. Screw on and tighten using 7/8-inch and 1-inch open-end wrenches.
36. Hose (2) and loader boom cylinder (3)	Clamp (4)	Screw on and tighten to same relative position as noted during removal using 1/4-inch flat-tip screwdriver.
37. Loader backhoe	Transmission	Check fluid level and add proper amount and grade (TM 5-2420-222-10).
38.	Engine	Start and run at high idle (TM 5-2420-222-10).
39.	Loader control valve-to-loader boom cylinder rod end oil lines	a. Operate lift arms (TM 5-2420-222-10) and check for leaks. b. If leaking at any connection, tighten using 7/8-inch and 1-inch open-end wrenches. c. If leaking does not stop, shut down engine (TM 5-2420-222-10) and replace leaking connection packing, hose, or fitting as outlined in this task. d. If found leaking, repeat steps 37 thru 39.
40.	Engine	If still running, shut down (TM 5-2420-222-10).

LOADER CONTROL VALVE-TO-LOADER BOOM CYLINDER ROD END OIL LINES - CONTINUED

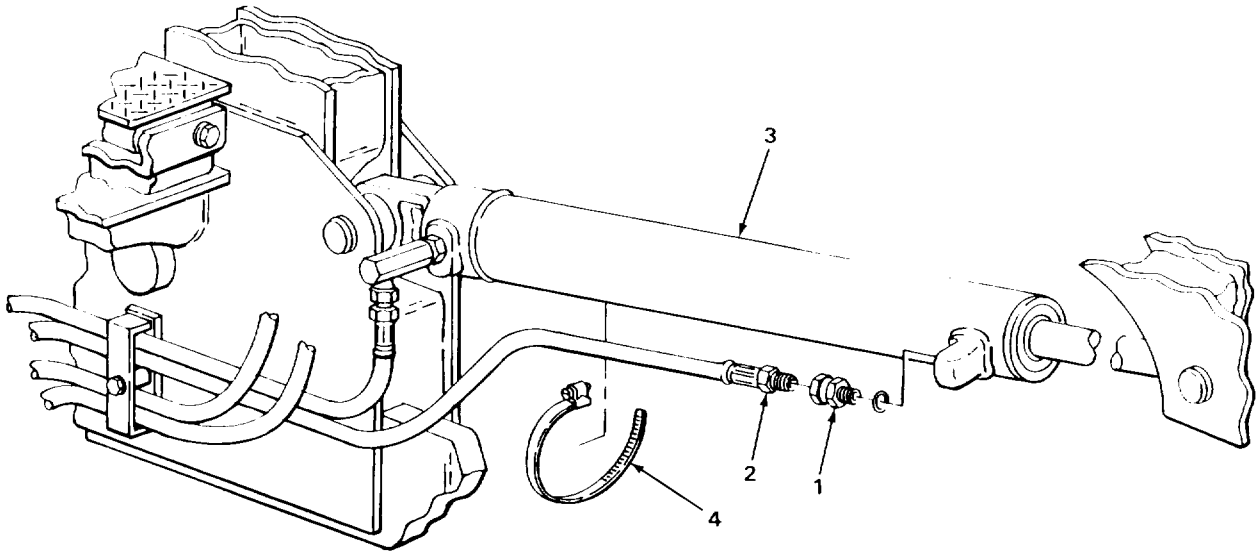

NOTE

FOLLOW-ON MAINTENANCE: Install right platform (page 2-1079).

TASK ENDS HERE

HYDRAULIC OIL FILTER

This task covers:

- a. Removal (page 2-1698)
- b. Disassembly (page 2-1700)
- c. Cleaning (page 2-1700)
- d. Inspection/Replacement (page 2-1700)
- e. Assembly (page 2-1701)
- f. Installation (page 2-1702)

INITIAL SETUP:

Tools

- Container, 1-gallon
- Handle, ratchet, 1/2-inch
- Knife, pocket
- Pliers, retaining ring
- Socket, 1/2-inch drive, 3/4-inch
- Wrench, torque, 1/2-inch drive
0 to 150 foot-pound capacity

Materials/Parts

- Element
- Fluid, hydraulic (LO 5-2420-222-12)
- Retainer

Materials/Parts - Continued

- Packing, special screw
- Packing, cover
- Rags, wiping (item 21, Appendix C)
- Solvent, drycleaning (item 28, Appendix C)

Personnel Required

Two

Equipment Condition

Hydraulic pressure released (page 2-1191)

LOCATION	ITEM	ACTION	REMARKS
----------	------	--------	---------

REMOVAL

WARNING

Be careful when draining hot fluids. Wear gloves to protect your hands from hot parts and fluids or severe burns could result.

- | | | |
|--|---|--|
| 1. Cover (1) and oil filter relief valve (2) | Special screw (3) | <ul style="list-style-type: none"> a. Place 1-gallon container underneath. b. Hold cover (1) in place. c. Using 3/4-inch, 1/2-inch drive socket and ratchet handle, unscrew until free valve (2). |
| 2. Oil filter relief valve (2) | Cover (1) with attached parts and special screw (3) | <ul style="list-style-type: none"> a. Take off. b. Allow fluid to drain into container. c. Get rid of drained fluid (page 2-137). |

HYDRAULIC OIL FILTER - CONTINUED

LOCATION	ITEM	ACTION	REMARKS
----------	------	--------	---------

- | | | | |
|--------------|-------------|--------------------------------|--|
| 3. Cover (1) | Packing (4) | a. Take off.
b. Get rid of. | |
|--------------|-------------|--------------------------------|--|

NOTE

If removing hydraulic oil filter for access purposes only skip step 4.

- | | | | |
|------------------------------------|-------------|--------------------------------|--|
| 4. Cover (1) and special screw (3) | Element (5) | a. Take out.
b. Get rid of. | |
|------------------------------------|-------------|--------------------------------|--|

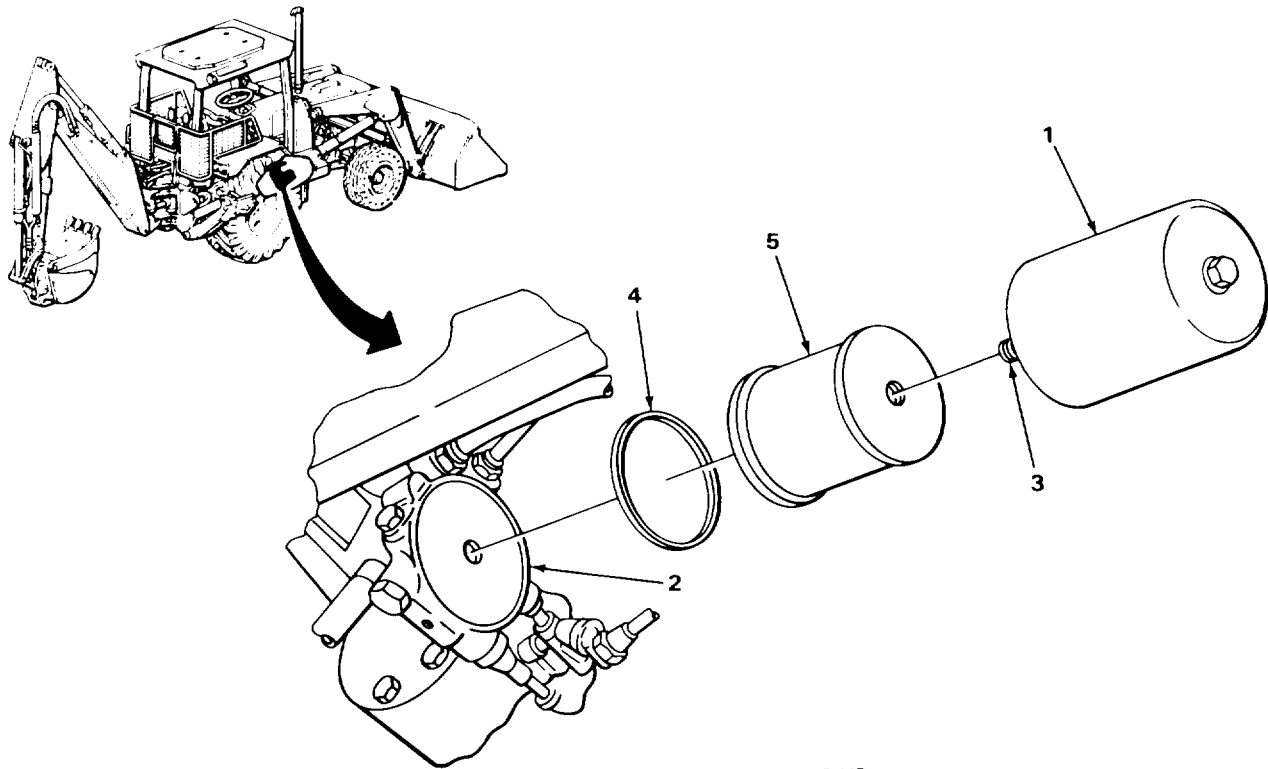

VIEW LOOKING UP

TA243544

HYDRAULIC OIL FILTER - CONTINUED

LOCATION	ITEM	ACTION	REMARKS
DISASSEMBLY			
5.	Special screw (1) and retainer (2)	Ring (3)	a. Have assistant hold down retainer (2). b. Using retaining ring pliers, take off. c. Have assistant release retainer (2).
6.		Retainer (2), packing (4), washer (5), spring (6), and cover (7)	a. Take off. b. Get rid of packing (4).
7.	Special screw (1)	Packing (8)	a. Using pocket knife, take off. b. Get rid of.

CLEANING

NOTE

For more information on how to clean parts, go to General Maintenance Instructions (page 2-137).

WARNING

Drycleaning solvent P-D-680 is toxic and flammable. Wear protective goggles and gloves and use only in a well ventilated area. Avoid contact with skin, eyes, and clothes and don't breathe vapors. Do not use near open flame or excessive heat. The flashpoint is 100°F to 138°F (38° to 59°C). If you become dizzy while using cleaning solvent, get fresh air immediately and get medical aid. If contact with eyes is made, wash your eyes with water and get medical aid immediately.

- | | | |
|----|-----------------|---|
| 8. | All metal parts | a. Clean in drycleaning solvent.
b. Using clean, dry rags, wipe dry. |
|----|-----------------|---|

INSPECTION/REPLACEMENT

NOTE

For more information on how to inspect parts, go to General Maintenance Instructions (page 2-137).

Replace defective parts as needed.

- | | | |
|----|-----------------|--|
| 9. | All metal parts | Look for cracks, breaks, and abnormal bends. |
|----|-----------------|--|

HYDRAULIC OIL FILTER - CONTINUED

LOCATION	ITEM	ACTION REMARKS
10.	Special screw (1)	Look for damaged threads.
ASSEMBLY		
11. Special screw (1)	New packing (8)	a. Lubricate with hydraulic fluid. b. Put on.
12. Special screw (1) and packing (8)	Cover (7), spring (6), washer (5), new packing (4), and retainer (2)	a. Lubricate packing (4) with hydraulic fluid. b. Put on.
13. Special screw (1) with assembled parts	Retainer (2)	Have assistant push down until groove on screw (1) is exposed and hold in this position.
14. Special screw (1) and retainer (2)	Ring (3)	Using retaining ring pliers, put on.
15. Special screw (1) with assembled parts	Retainer (2)	Have assistant release.

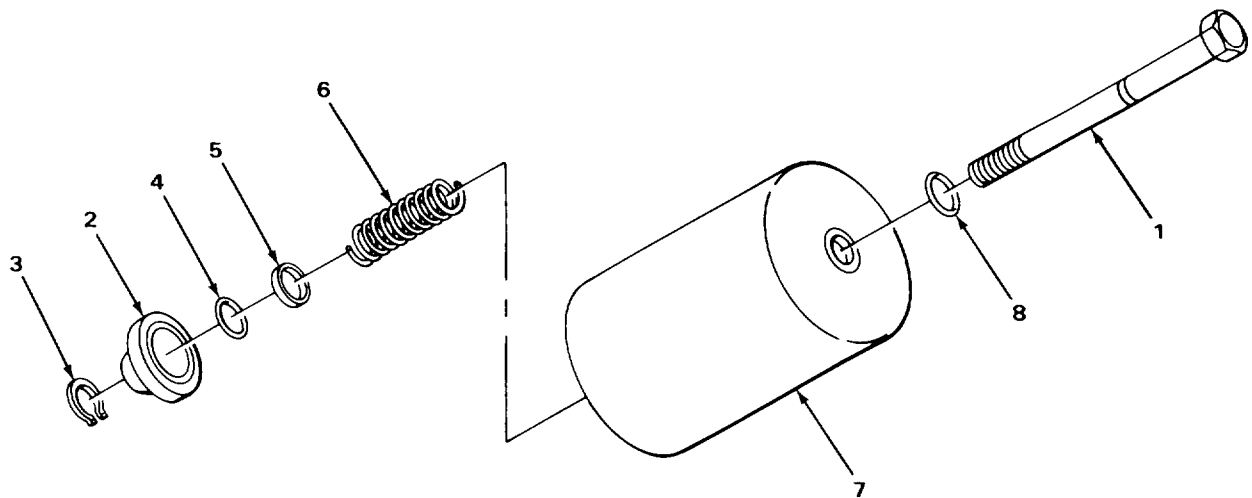

HYDRAULIC OIL FILTER - CONTINUED

LOCATION	ITEM	ACTION	REMARKS
INSTALLATION			
16. Cover (1) and special screw (2)	New element (3)	Put in position.	
17. Cover (1)	New packing (4)	a. Lubricate with hydraulic fluid. b. Place in position.	
18. Oil filter relief valve (5)	Cover (1) with assembled parts and special screw (2)	a. Screw in and tighten until snug using 3/4-inch, 1/2-inch drive socket and ratchet handle. b. Using 3/4-inch, 1/2-inch drive socket and 0 to 150 foot-pound capacity torque wrench, tighten to 55 foot-pounds (75 N.m) torque.	
19. Loader backhoe	Transmission	Check fluid level and add proper amount and grade (TM 5-2420-222-10).	
20.	Engine	Start (TM 5-2420-222-10).	
21. Oil filter relief valve (5)	Cover (1) and special screw (2)	a. Check for leaks. b. If leaking, shut down engine (TM 5-2420-222-10) and replace leaking packing or packings as outlined in this task.	

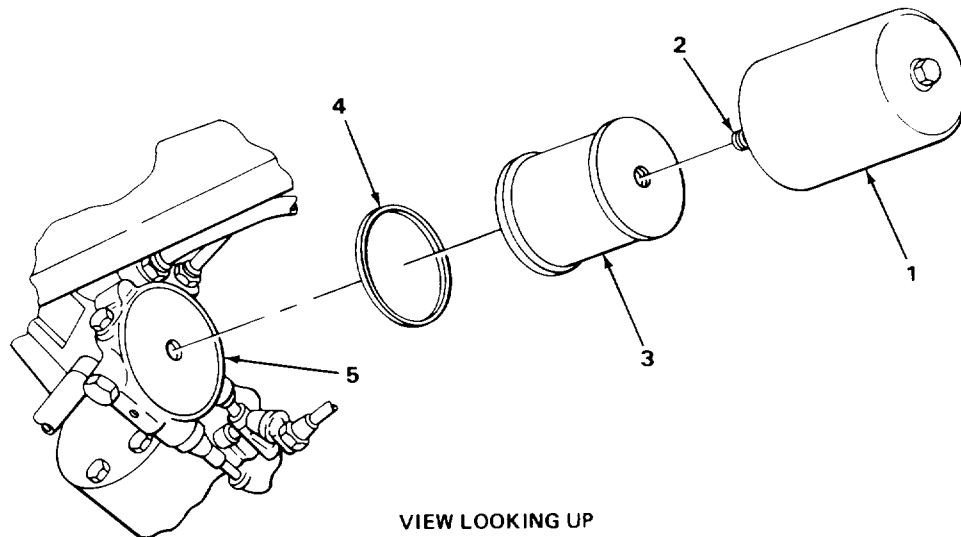

TASK ENDS HERE

TA243546

JAW CYLINDER

This task covers:

- a. Removal (page 2-1704)
 - b. Disassembly (page 2-1704)
 - c. Cleaning (page 2-1704)
 - d. Inspection/Replacement (page 2-1706)
 - e. Assembly (page 2-1706)
 - f. Installation (page 2-1706)
-

INITIAL SETUP:

Tools

Block, wood
Driftpin, brass-tipped, 3/4-inch
Hammer, ball-peen, 2-pound head
Handle, ratchet, 1/4-inch drive
Pliers, retaining ring
Pliers, slip-joint, multiple tongue
and groove
Punch, drive-pin, straight, 1/4-inch
Socket, 1/4-inch drive, 5/16-inch
Wrench, open-end, 7/16-inch

Materials/Parts

Pin, cotter, jaw cylinder pin
Rags, wiping (item 21, Appendix C)
Solvent, drycleaning (item 28, Appendix C)

Personnel Required

Two

Equipment Condition

1. Backhoe bucket jaw open
(TM 5-2420-222-10)
2. Jaw cylinder oil hoses removed
(page 2-1544)

2-1703

JAW CYLINDER - CONTINUED

LOCATION	ITEM	ACTION REMARKS
REMOVAL		
1. Inner bucket (1) and pin (2)	Two snaprings (3)	Using retaining ring pliers, take out.
2. Inner bucket (1) and jaw cylinder (4)	Pin (2)	With aid of assistant, using 3/4-inch brass-tipped driftpin and 2-pound head ball-peen hammer, tap out.
3. Jaw (5) and clevis pin (6)	Cotter pin (7)	a. Using multiple tongue and groove slip- joint pliers, straighten ends and take out. b. Get rid of.
4. Jaw (5) and pin (8)	Clevis pin (6)	Using 1/4-inch straight drive-pin punch and 2-pound head ball-peen hammer, tap out.
5. Jaw (5) and jaw cylinder (4)	Pin (8)	With aid of assistant, using 3/4-inch brass-tipped driftpin and 2-pound head ball-peen hammer, tap out.
6. Inner bucket (1) and jaw (5)	Jaw cylinder (4)	With aid of assistant, take off.
DISASSEMBLY		
7. Jaw cylinder (4)	Grease fitting (9)	Using 7/16-inch open-end wrench, unscrew and take off.
8. Pin (8)	Grease fitting (10)	Using 5/16-inch, 1/4-inch drive socket and ratchet handle, unscrew and take out.

CLEANING

NOTE

For more information on how to clean parts, go to General Maintenance Instructions (page 2-137).

JAW CYLINDER - CONTINUED

LOCATION	ITEM	ACTION	REMARKS
----------	------	--------	---------

WARNING

Drycleaning solvent P-D-680 is toxic and flammable. Wear protective goggles and gloves and use only in a well ventilated area. Avoid contact with skin, eyes, and clothes and don't breathe vapors. Do not use near open flame or excessive heat. The flashpoint is 100°F to 138°F (38° to 59°C). If you become dizzy while using cleaning solvent, get fresh air immediately and get medical aid. If contact with eyes is made, wash your eyes with water and get medical aid immediately.

- | | | |
|-----|-----------------------|--|
| 9. | Jaw cylinder (4) | <ul style="list-style-type: none"> a. Using clean rags dampened with dry-cleaning solvent, wipe clean. b. Using clean, dry rags, wipe dry. |
| 10. | All other metal parts | <ul style="list-style-type: none"> a. Clean in drycleaning solvent. b. Using clean, dry rags, wipe dry. |

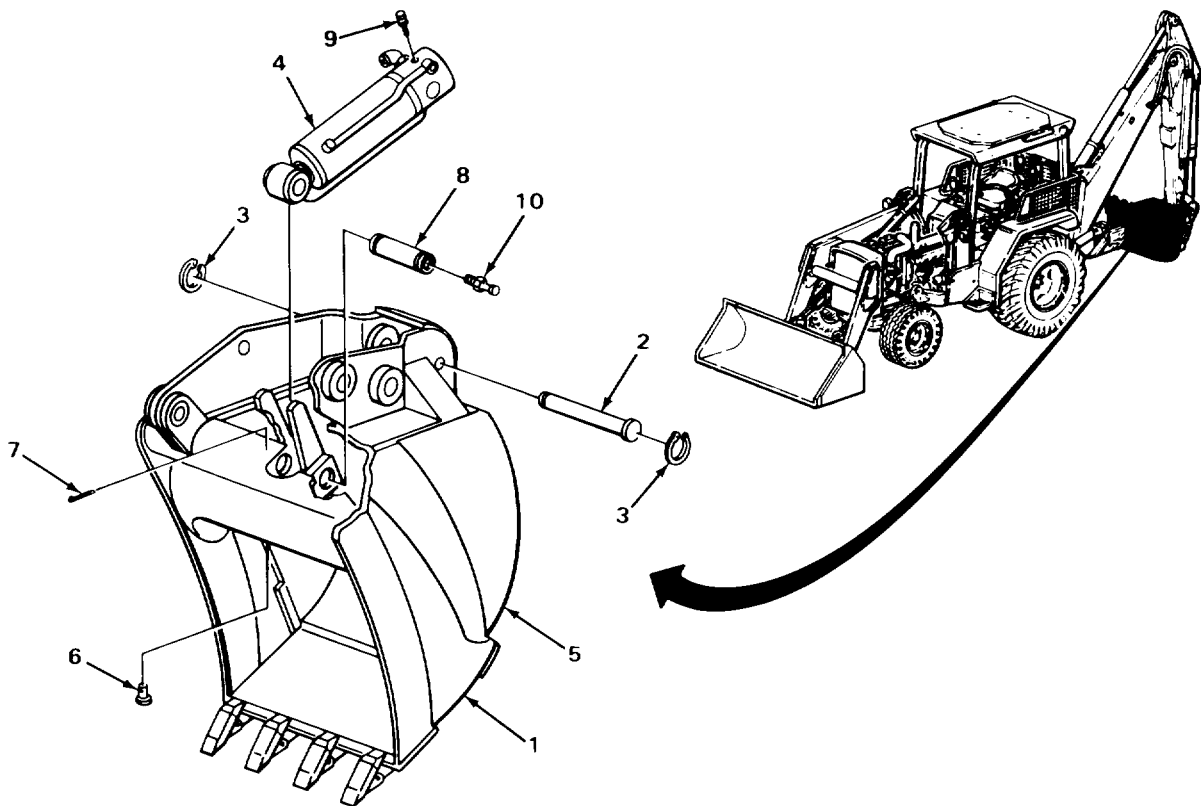

JAW CYLINDER - CONTINUED

LOCATION	ITEM	ACTION REMARKS	
INSPECTION/REPLACEMENT			
NOTE			
For more information on how to inspect parts, go to General Maintenance Instructions (page 2-137).			
Replace defective parts as needed.			
11.	Jaw cylinder (1)	Look for cracks and breaks.	
12.	All threaded parts	Look for damaged threads.	
ASSEMBLY			
13.	Pin (2)	Grease fitting (3)	Screw on and tighten using 5/16-inch, 1/4-inch drive socket and ratchet handle.
14.	Jaw cylinder (1)	Grease fitting (4)	Screw on and tighten using 7/16-inch open-end wrench.
INSTALLATION			
15.	Inner bucket (5) and jaw (6)	Jaw cylinder (1)	With aid of assistant, place into position and support.
16.	Jaw (6) and cylinder (1)	Pin (2)	With aid of assistant, using 2-pound head ball-peen hammer and wood block, tap in.
17.	Jaw (6) and pin (2)	Clevis pin (7)	Using 2-pound head ball-peen hammer, tap in.
18.	Jaw (6) and clevis pin (7)	Cotter pin (8)	a. Push in. b. Using multiple tongue and groove slip-joint pliers, bend ends back.
19.	Inner bucket (5) and jaw cylinder (1)	Pin (9)	With aid of assistant, using 2-pound head ball-peen hammer and wood block, tap in.
20.	Inner bucket (5) and pin (9)	Two snaprings (10)	Using retaining ring pliers, put on.

JAW CYLINDER - CONTINUED

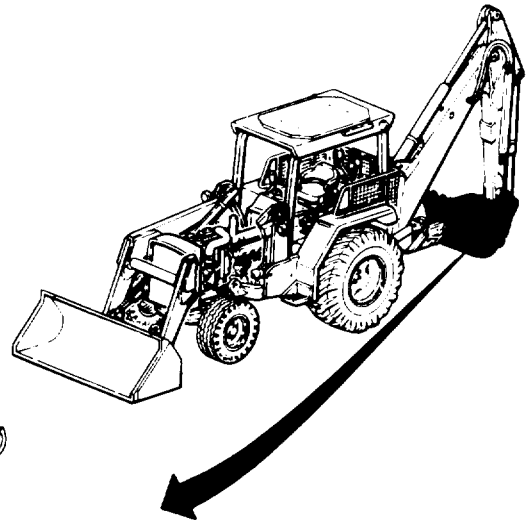
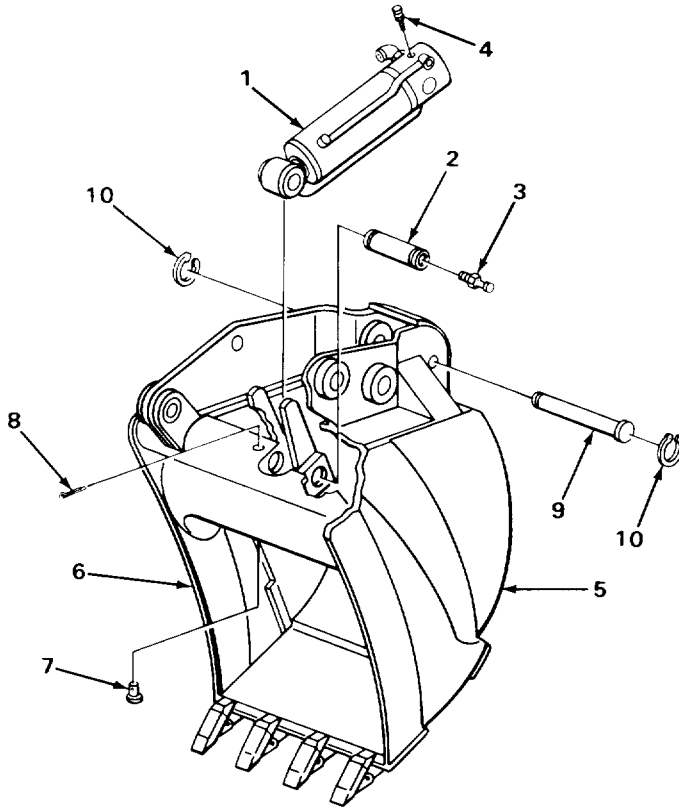

NOTE

FOLLOW-ON MAINTENANCE: Install jaw cylinder oil hoses (page 2-1544).

TASK ENDS HERE

BACKHOE SWING CYLINDERS

This task covers:

- a. Removal (page 2-1709)
 - b. Disassembly (page 2-1714)
 - c. Cleaning (page 2-1716)
 - d. Inspection/Replacement (page 2-1717)
 - e. Assembly (page 2-1717)
 - f. Installation (page 2-1718)
-

INITIAL SETUP

Tools

- Backhoe swing cylinder pin removal tool (Appendix D)
- Block, wood
- Driftpin, brass-tipped, 3/4-inch
- Hammer, ball-peen, 1-pound head
- Hammer, ball-peen, 2-pound head
- Handle, ratchet, 1/2-inch
- Handle, ratchet, 3/4-inch
- Knife, pocket
- Pan, drain
- Pliers, retaining ring
- Pliers, slip-joint multiple tonque and groove
- Punch, drive-pin, straight, 1/4-inch
- Socket, 1/2-inch drive, 15/16-inch
- Socket, 3/4-inch drive, 11/8-inch
- Wrench, open-end, 5/16-inch
- Wrench, open-end, 7/16-inch
- Wrench, open-end, 5/8-inch
- Wrench, open-end, 11/16-inch
- Wrench, open-end, 7/8-inch (two required)
- Wrench, open-end, 1-inch
- Wrench, open-end, 1 1/16-inch
- Wrench, open-end, 11/8-inch
- Wrench, open-end, 11/4-inch
- Wrench, open-end, 1 3/8-inch

Materials/Parts

- Cotter pin, swing frame pin (two required)
- Packing, elbow to cylinder
- Packing, elbow to cylinder
- Rags, wiping (item 21, Appendix C)
- Solvent, drycleaning (item 28, Appendix C)
- Tags, marking (item 30, Appendix C)

Personnel Required

Two

Equipment Condition

1. Backhoe valve box cover removed (page 2-1157)
2. Backhoe valve bottom cover removed (page 2-1154)
3. Hydraulic system pressure released (page 2-1191)

LOCATION	ITEM	ACTION	REMARKS
----------	------	--------	---------

NOTE

Both backhoe swing cylinders are maintained the same way except as noted. One side is shown. Repeat procedures for other side as needed.

BACKHOE SWING CYLINDERS - CONTINUED

LOCATION	ITEM	ACTION	REMARKS
----------	------	--------	---------

REMOVAL

WARNING

Do not attempt to disconnect hydraulic lines and fittings while engine is running or before hydraulic system pressure has been released. When engine is running, hydraulic system is under pressure. Hydraulic system pressure should be 0 psi (0 kPa) before lines are disconnected. A line or fitting disconnected under pressure will blow off with a lot of force and could cause serious injury to personnel.

Be careful when draining hot fluids. Wear gloves to protect your hands from hot parts and fluids or severe burns could result.

NOTE

If removing left swing cylinder, skip steps 1 and 2.

- | | | |
|--------------|----------|---|
| 1. Elbow (1) | Hose (2) | <ul style="list-style-type: none"> a. Place drain pan underneath. b. Using 7/8-inch and 1-inch open-end wrenches, unscrew and take off. c. Cap (page 2-137). d. Tag (page 2-137). |
|--------------|----------|---|

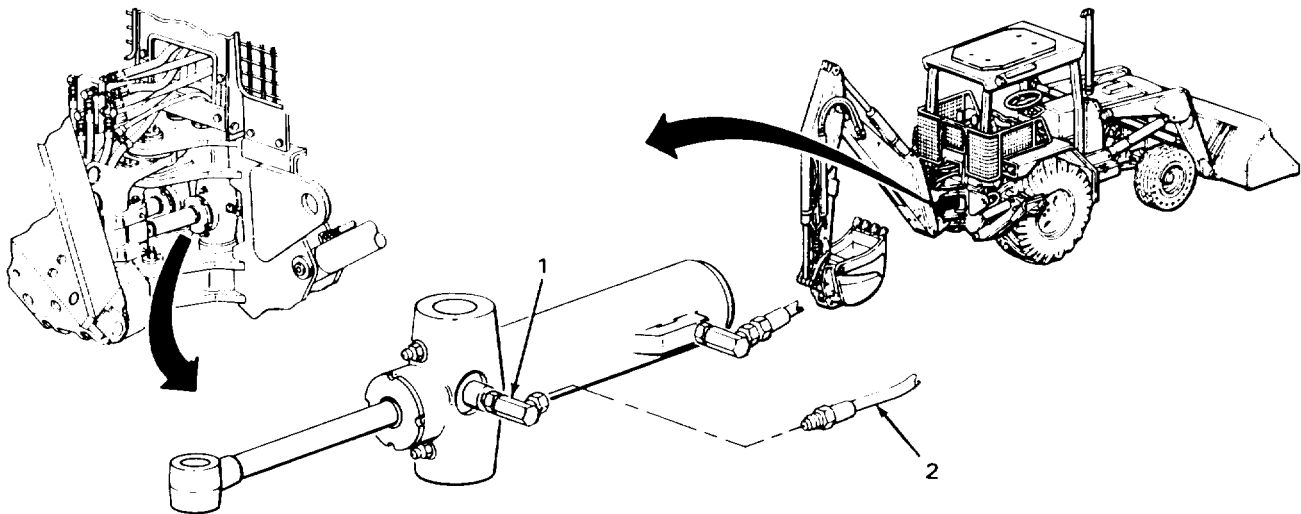

BACKHOE SWING CYLINDERS - CONTINUED

LOCATION	ITEM	ACTION	REMARKS
REMOVAL - CONTINUED			
2. Elbow (1)	Hose (2)	a. Place drain pan underneath. b. Using 7/8-inch and 1-inch open-end wrenches, unscrew and take off. c. Cap (page 2-137). d. Tag (page 2-137).	

WARNING

Do not attempt to disconnect hydraulic lines and fittings while engine is running or before hydraulic system pressure has been released. When engine is running, hydraulic system is under pressure. Hydraulic system pressure should be 0 psi (0 kPa) before lines are disconnected. A line or fitting disconnected under pressure will blow off with a lot of force and could cause serious injury to personnel.

Be careful when draining hot fluids. Wear gloves to protect your hands from hot parts and fluids or severe burns could result.

NOTE

If removing right swing cylinder, skip steps 3 and 4.

3. Elbow(3)	Hose (4)	a. Place drain pan underneath. b. Using 7/8-inch and 11/16-inch open-end wrenches, unscrew and take off. c. Cap (page 2-137). d. Tag (page 2-137).	
4. Elbow (5)	Hose (6)	a. Place drain pan underneath. b. Using 7/8-inch and 11/16-inch open-end wrenches, unscrew and take off. c. Cap (page 2-137). d. Tag (page 2-137).	

NOTE

Some swing cylinders have linkage pins retained by cotter pins, some have pins retained by retaining rings. For swing cylinders equipped with retaining rings, skip steps 5 and 6.

5. Pin (7) and two washers (8)	Two cotter pins (9)	a. Using multiple tongue and groove slip-joint pliers, straighten ends. b. Using 1/4-inch straight drive-pin punch and 2-pound head ball-peen hammer, drive out. c. Get rid of.	
--------------------------------	---------------------	---	--

BACKHOE SWING CYLINDERS - CONTINUED

LOCATION	ITEM	ACTION	REMARKS
----------	------	--------	---------

6. Swing frame (10) and pin (7)	Two washers (8)	Take off.	
---------------------------------	-----------------	-----------	--

NOTE

For swing cylinders equipped with cotter pins, skip step 7.

7. Swing frame (10) and pin (11)	Two rings (12)	Using retaining ring pliers, take off.	
----------------------------------	----------------	--	--

8. Swing frame (10) and swing cylinder (13 and 14)	Pin (7 or 11)	Using 3/4-inch brass-tipped driftpin and 2-pound head ball-peen hammer, drive out.	
--	---------------	--	--

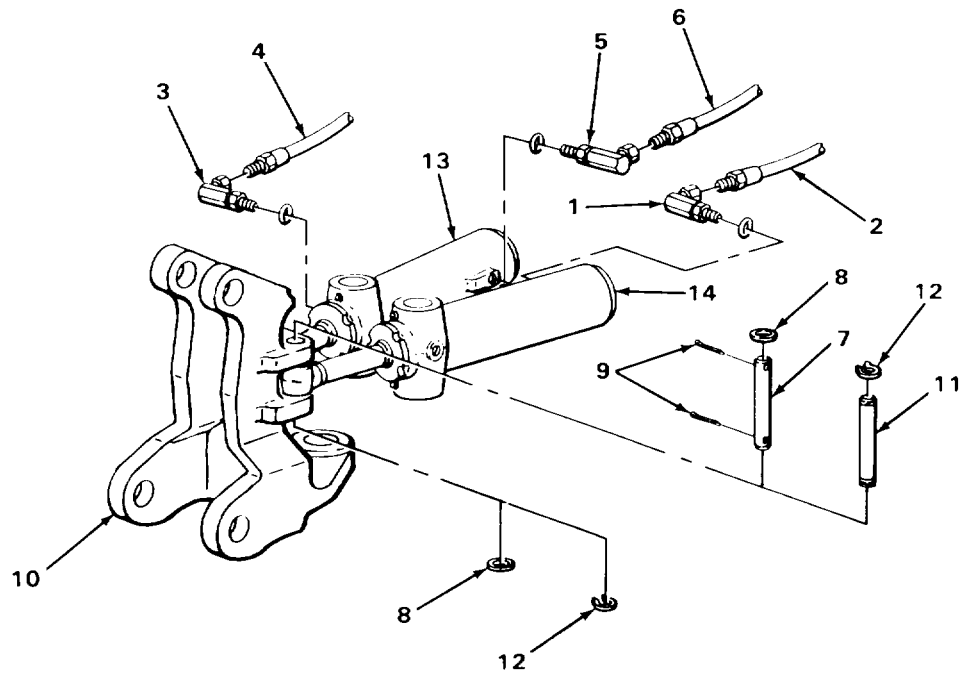
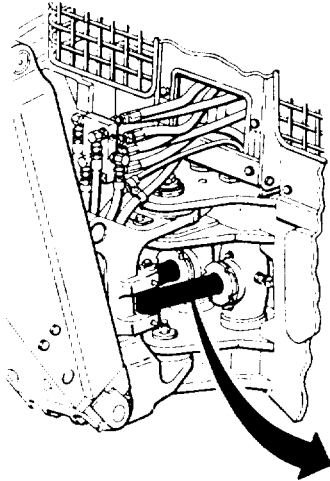

TA243550

BACKHOE SWING CYLINDERS - CONTINUED

LOCATION	ITEM	ACTION	REMARKS
REMOVAL - CONTINUED			
NOTE			
If removing left swing cylinder, skip step 9.			
9. Union adapter (1)	Hose (2)	<ul style="list-style-type: none"> a. Place drain pan underneath. b. Using 7/8-inch and 1-inch open-end wrenches, unscrew and take out. c. Plug adapter (1) (page 2-137). d. Tag (page 2-137). e. Get rid of drained fluid (page 2-137). 	
NOTE			
If removing right swing cylinder, skip steps 10 thru 15.			
10. Special adapter (3)	Hose (4)	<ul style="list-style-type: none"> a. Place drain pan underneath. b. Using 1 1/8-inch and 1 1/4-inch open-end wrenches, unscrew and take out. c. Cap (page 2-137). d. Plug adapter (3) (page 2-137). e. Tag (page 2-137). 	
11. Union adapter (5)	Special adapter (3)	<ul style="list-style-type: none"> a. Using 1 1/4-inch and 1 3/8-inch open-end wrenches, unscrew and take out. b. Cap (page 2-137). c. Plug adapter (5) (page 2-137). d. Tag (page 2-137). 	
12. Special adapter (6)	Hose (7)	<ul style="list-style-type: none"> a. Using 1 1/16-inch and 1 1/4-inch open-end wrenches, unscrew and take out. b. Cap (page 2-137). c. Tag (page 2-137). 	
13. Union adapter (8)	Special adapter (6)	<ul style="list-style-type: none"> a. Using 1 1/4-inch and 1 3/8-inch open-end wrenches, unscrew and take out. b. Plug adapter (8) (page 2-137). c. Tag (page 2-137). 	
14. Union adapter (9)	Hose (10)	<ul style="list-style-type: none"> a. Using 11/16-inch and 7/8-inch open-end wrenches, unscrew and take out. b. Cap (page 2-137). c. Plug adapter (9) (page 2-137). d. Tag (page 2-137). 	

BACKHOE SWING CYLINDERS - CONTINUED

LOCATION	ITEM	ACTION REMARKS
15. Two straight adapters (11 and 12)	Two hoses (13 and 14)	a. Using 7/8-inch and 1-inch open-end wrenches, unscrew and take out. b. Cap (page 2-137). c. Plug adapters (11 and 12) (page 2-137). d. Tag (page 2-137). e. Get rid of drained fluid (page 2-137).
16. Main frame (15) and retainer (16)	Two screws (17)	Using 15/16-inch, 1/2-inch drive socket and ratchet handle, unscrew and take out.
17. Sleeve (18)	Retainer (16)	Take off.

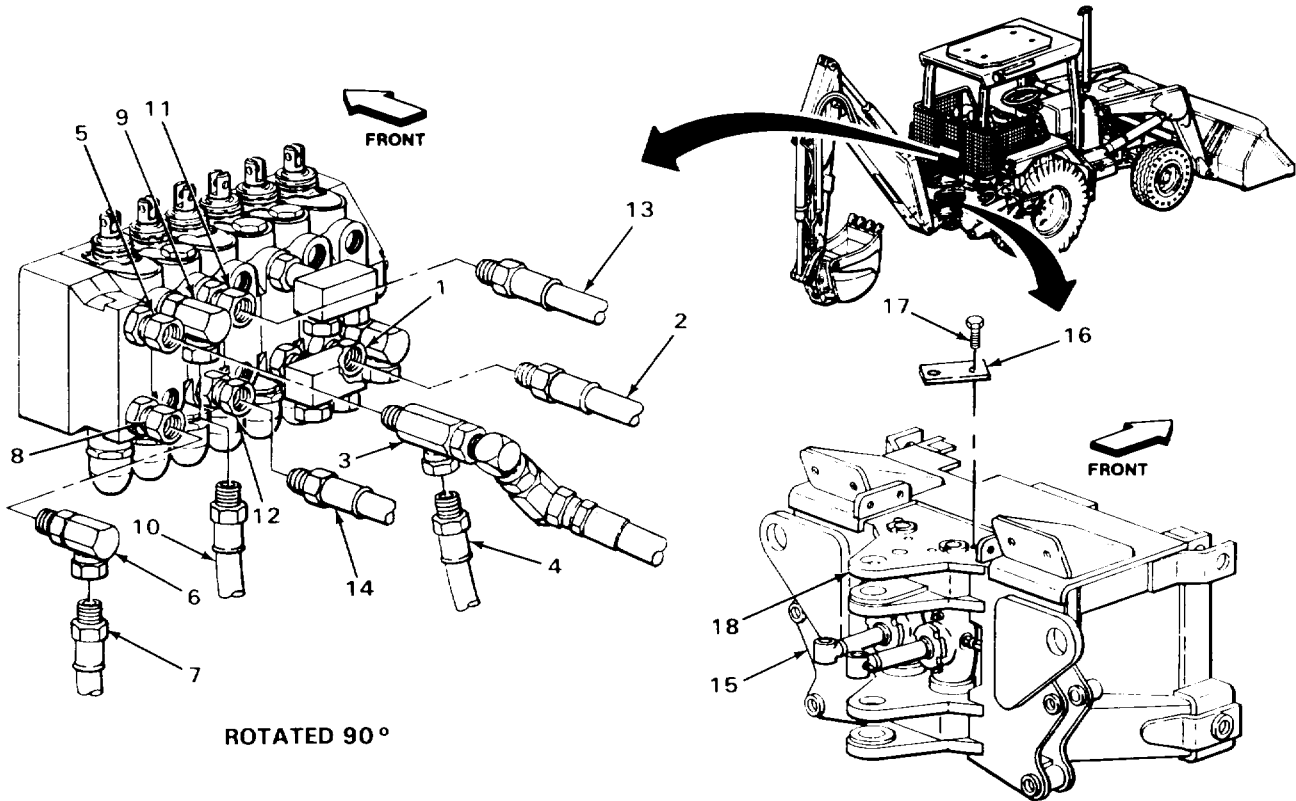

TA243551

BACKHOE SWING CYLINDERS - CONTINUED

LOCATION	ITEM	ACTION REMARKS
REMOVAL - CONTINUED		
18. Main frame (1) and swing cylinder (2)	Sleeve (3) and pin (4)	Using backhoe swing cylinder pin removal tool and 1 1/8-inch, 3/4-inch drive socket and ratchet handle, pull out.
19. Pin (4)	Sleeve (3)	Using 1-pound head ball-peen hammer, tap off.
20. Main frame (1)	Sleeve (5)	Take out.
21. Main frame (1) and retainer (6)	Two screws (7)	Using 15/16-inch, 1/2-inch drive socket and ratchet handle, unscrew and take out.
22. Sleeve (8)	Retainer (6)	Take off.
23. Main frame (1) and swing cylinder (2)	Sleeve (8) and pin (9)	Using backhoe swing cylinder pin removal tool and 1 1/8-inch, 3/4-inch drive socket and ratchet handle, pull out.
24. Pin (9)	Sleeve (8)	Using 1-pound ball-peen hammer, tap off.
25. Main frame (1)	Sleeve (10)	Take out.

WARNING

Some parts are heavy. Be careful when handling them. Lifting equipment is needed when parts weigh over 50 pounds (23 kg) for a single person lift, over 100 pounds (45 kg) for a two person lift, and over 150 pounds (68 kg) for a three or more person lift. Do not try to handle heavy parts without lifting equipment. Keep clear of heavy parts supported only by lifting equipment. Failure to observe this precaution could cause serious injury or death of personnel.

26. Main frame (1) and swing frame (11)	Swing cylinder (2)	With aid of assistant, take out.
---	-----------------------	----------------------------------

DISASSEMBLY

27. Swing cylinder (2)	Grease fitting (12)	Using 5/16-inch open-end wrench, unscrew and take out.
28. Swing cylinder (2)	Two grease fittings (13)	Using 7/16-inch open-end wrench, unscrew and take out.

BACKHOE SWING CYLINDERS - CONTINUED

LOCATION	ITEM	ACTION	REMARKS
----------	------	--------	---------

29. Swing cylinder (2) and elbow (14)	Nut (15)	Using 5/8-inch and 11/16-inch open-end wrenches, loosen.
---------------------------------------	----------	--

NOTE

Swing cylinder elbows have different hose fittings for right and left cylinders. Do not mix parts.

30. Swing cylinder (2)	Elbow (14) with assembled parts	a. Not relative position for proper placement during assembly. b. Using 5/8-inch open-end wrench, unscrew and take out. c. Tag (page 2-137). d. Plug cylinder (2) (page 2-137).
------------------------	---------------------------------	--

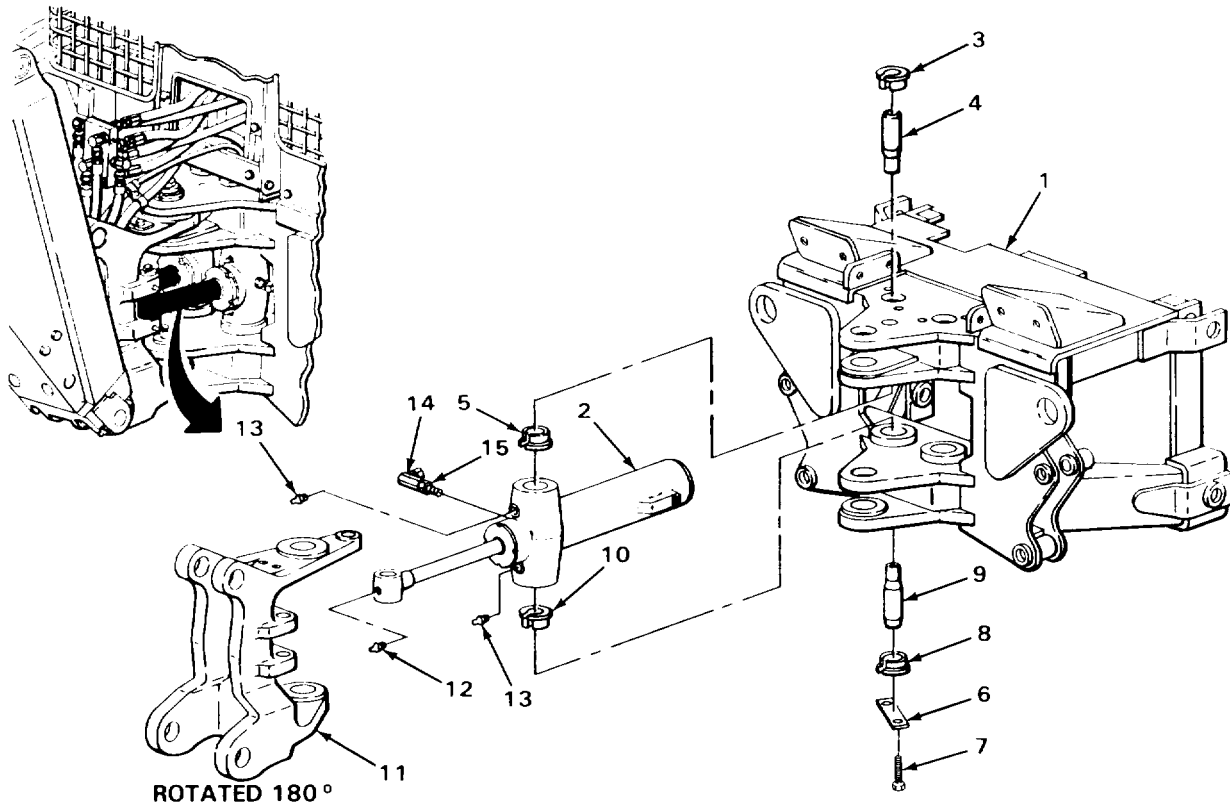

TA243552

BACKHOE SWING CYLINDERS - CONTINUED

LOCATION	ITEM	ACTION REMARKS
DISASSEMBLY - CONTINUED		
31. Elbow (1)	Packing (2)	a. Using pocket knife, take off. b. Get rid of.
32. Swing cylinder (3) and elbow (4)	Nut (5)	Using two 7/8-inch open-end wrenches, loosen.
33. Swing cylinder (3)	Elbow (4) with assembled parts	a. Note relative position for proper placement during assembly. b. Using 7/8-inch open-end wrench, unscrew and take out. c. Tag (page 2-137). d. Plug cylinder (3) (page 2-137).
34. Elbow (4)	Packing (6)	a. Using pocket knife, take out. b. Get rid of.

CLEANING

NOTE

For more information on how to clean parts, go to **General Maintenance Instructions (page 2-137)**.

WARNING

Drycleaning solvent P-D-680 is toxic and flammable. Wear protective goggles and gloves and use only in a well ventilated area. Avoid contact with skin, eyes, and clothes and don't breathe vapors. Do not use near open flame or excessive heat. The flashpoint is 100°F to 138°F (38° to 59°C). If you become dizzy while using cleaning solvent, get fresh air immediately and get medical aid. If contact with eyes is made, wash your eyes with water and get medical aid immediately.

35.	Swing cylinder (3)	a. Using clean rags dampened with dry- cleaning solvent, wipe clean. b. Using clean, dry rags, wipe dry.
36.	All other metal parts	a. Clean in dry-cleaning solvent. b. Using clean, dry rags, wipe dry.

BACKHOE SWING CYLINDERS - CONTINUED

LOCATION	ITEM	ACTION	REMARKS
----------	------	--------	---------

INSPECTION/REPLACEMENT

NOTE

For more information on how to inspect parts, go to General Maintenance Instructions (page 2-137).

Replace defective parts as needed.

- | | | |
|-----|--------------------|-----------------------------|
| 37. | Swing cylinder (3) | Look for cracks and breaks. |
| 38. | All threaded parts | Look for damaged threads. |

ASSEMBLY

- | | | | |
|-----|-----------------|--------------------|-----------------------|
| 39. | Elbow (4) | Nut (5) | Screw on all the way. |
| 40. | New packing (6) | Place in position. | |

NOTE

Swing cylinder elbows have different hose fittings for right and left cylinders. Do not mix parts.

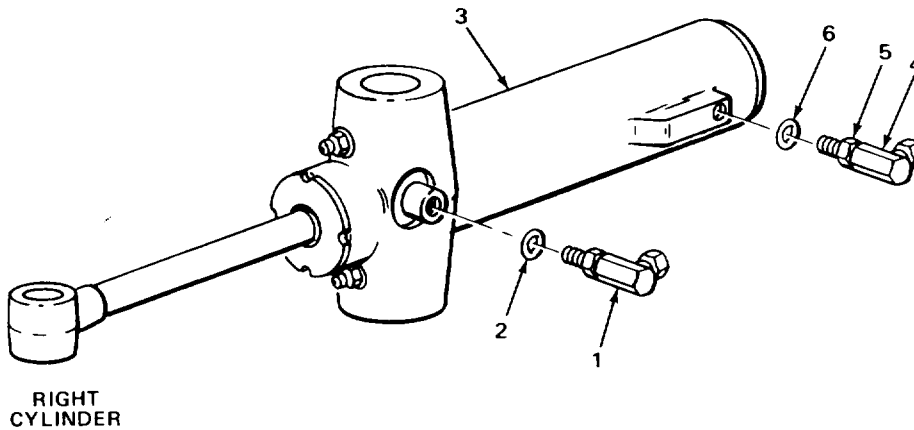

BACKHOE SWING CYLINDERS - CONTINUED

LOCATION	ITEM	ACTION	REMARKS
NOTE			
Swing cylinder elbows have different hose fittings for right and left cylinders. Do not mix parts.			
41. Swing cylinder (1)	Elbow (2) with assembled parts	a. Unplug cylinder (1). b. Take off tag. c. Screw in to same relative position as noted during disassembly using 7/8-inch open-end wrench.	
42. Elbow (2) and swing cylinder (1)	Nut (3)	Using two 7/8-inch open-end wrenches, tighten until snug against cylinder (1).	
43. Elbow (4)	Nut (5)	Screw on all the way.	
44.	New packing (6)	Place into position.	
45. Swing cylinder (1)	Elbow (4) with assembled parts	a. Unplug cylinder (1). b. Take off tag. c. Screw in to same relative position as noted during disassembly using 5/8-inch open-end wrench.	
46. Elbow (4) and swing cylinder (1)	Nut (5)	Using 5/8-inch and 11/16-inch open-end wrenches, tighten until snug against cylinder (1).	
47. Swing cylinder (1)	Two grease fittings (7)	Screw in and tighten using 7/16-inch open-end wrench.	
48.	Grease fitting (8)	Screw in and tighten using 5/16-inch open-end wrench.	

INSTALLATION

WARNING

Some parts are heavy. Be careful when handling them. Lifting equipment is needed when parts weigh over 50 pounds (23 kg) for a single person lift, over 100 pounds (45 kg) for a two person lift, and over 150 pounds (68 kg) for a three or more person lift. Do not try to handle heavy parts without lifting equipment. Keep clear of heavy parts supported only by lifting equipment. Failure to observe this precaution could cause serious injury or death of personnel.

BACKHOE SWING CYLINDERS - CONTINUED

LOCATION	ITEM	ACTION REMARKS
49. Main frame (9) and swing frame (10)	Swing cylinder (1)	With aid of assistant, place in position.
50. Main frame (9)	Sleeve (11)	Place into position.
51. Main frame (9) swing cylinder (1) and sleeve (10)	Pin (12)	Using 2-pound head ball-peen hammer and wood block, tap in.
52. Main frame (9) and pin (12)	Sleeve (13)	Using 2-pound head ball-peen hammer and wood block, tap into position.
53. Sleeve (13)	Retainer (14)	Place into position.

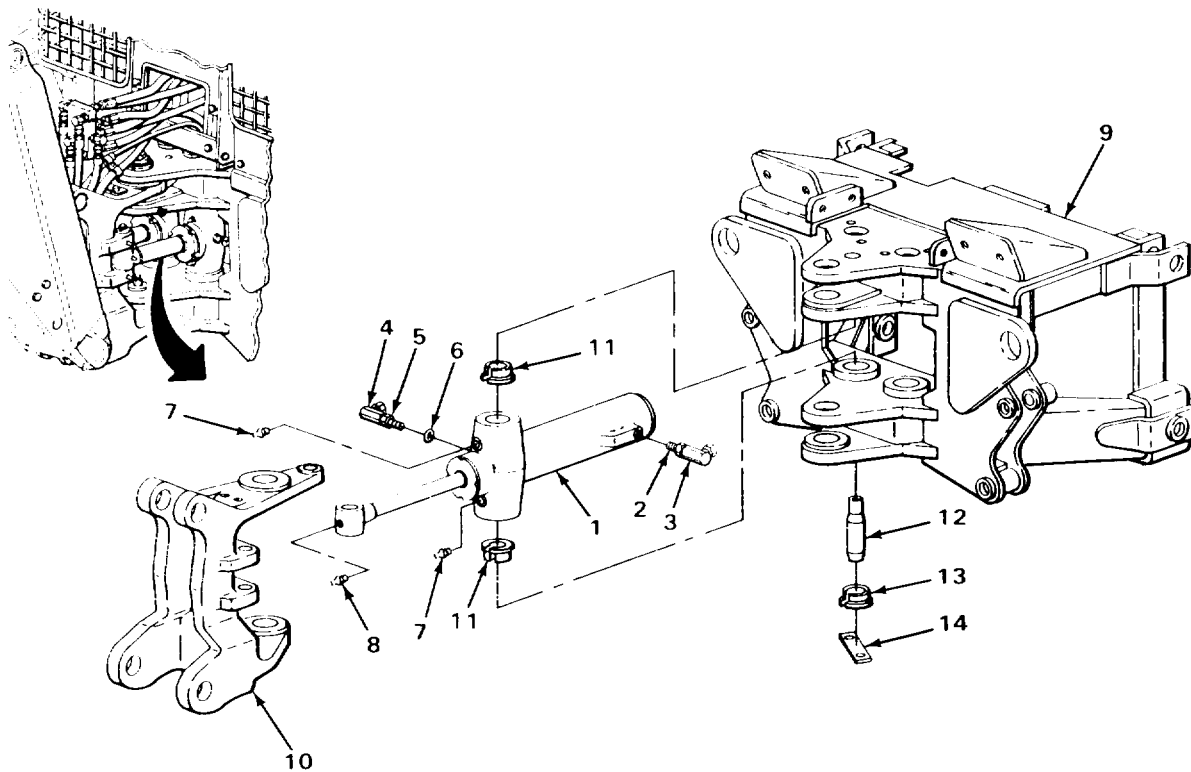

TA243554

BACKHOE SWING CYLINDERS - CONTINUED

LOCATION	ITEM	ACTION	REMARKS
INSTALLATION - CONTINUED			
54.	Main frame (1) and retainer (2)	Two screws (3)	Screw in and tighten using 15/16-inch, 1/2-inch drive socket and ratchet handle.
55.	Main frame (1)	Sleeve (4)	Place in position.
56.	Main frame (1) swing cylinder (5), and sleeve (4)	Pin (6)	Using 2-pound head ball-peen hammer and wood block, tap in.
57.	Main frame (1) and pin (6)	Sleeve (7)	Using 2-pound head ball-peen hammer and wood block, tap into position.
58.	Sleeve (7)	Retainer (8)	Place into position.
59.	Retainer (8) and main frame (1)	Two screws (9)	Screw in and tighten using 15/16-inch, 1/2-inch drive socket and ratchet handle.

NOTE

If installing left swing cylinder, skip step 60.

60.	Union adapter (10)	Hose(11)	a. Takeoff tag. b. Unplug adapter (10). c. Screw in and tighten using 7/8-inch and 1-inch open-end wrenches.
-----	-----------------------	----------	---

NOTE

If installing right swing cylinder, skip steps 61 thru 66.

61.	Two straight adapters (12 and 13)	Two hoses (14 and 15)	a. Take off tags. b. Unplug adapters (12 and 13). c. Uncap. d. Screw in and tighten using 7/8-inch and 1-inch open-end wrenches.
62.	Union adapter (16)	Hose (17)	a. Take off tag. b. Unplug adapter (16). c. Uncap. d. Screw in and tighten using 11/16-inch and 7/8-inch open-end wrenches.

BACKHOE SWING CYLINDERS - CONTINUED

LOCATION	ITEM	ACTION	REMARKS
63. Union adapter (18)	Special adapter (19)	a. Take off tag. b. Unplug adapter (18). c. Screw in and tighten using 1 1/4-inch and 1 3/8-inch open-end wrenches.	
64. Special adapter (19)	Hose (20)	a. Take off tag. b. Uncap. c. Screw in and tighten using 1 1/16-inch and 1 1/4-inch open-end wrenches.	
65. Union adapter (21)	Special adapter (22)	a. Take off tag. b. Unplug adapter (21). c. Uncap. d. Screw in and tighten using 1 1/4-inch and 1 3/8-inch open-end wrenches.	

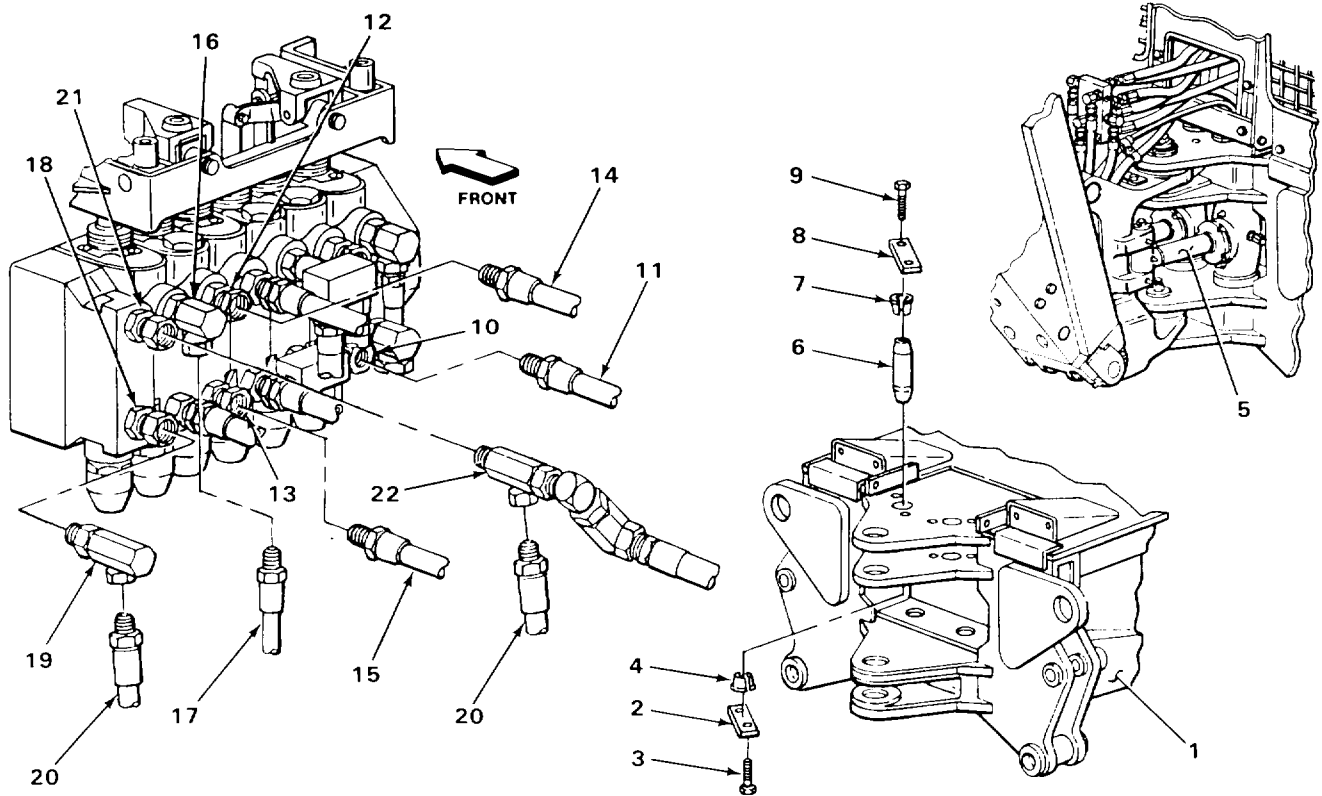

TA2435555

BACKHOE SWING CYLINDERS - CONTINUED

LOCATION	ITEM	ACTION	REMARKS
INSTALLATION - CONTINUED			
66. Special adapter (1)	Hose (2)	a. Take off tag. b. Unplug adapter. c. Uncap. d. Screw in and tighten using 1 1/8-inch and 1 1/4-inch open-end wrenches.	
67. Swing frame (3) and swing cylinder (4 or 5)	Pin (6 or 7)		Using 2-pound head ball-peen hammer and wood block, tap in.

NOTE

Some swing cylinders have linkage pins retained by cotter pins, some have pins retained by retaining rings. For swing cylinders equipped with retaining rings, skip steps 68 and 69.

68. Swing frame (3) and swing cylinder (4 or 5)	Pin (6 or 7)		Using 2-pound head ball-peen hammer and wood block, tap in.
69. Swing frame (3) and pin (6)	Two washers (8)		Place in position.
70. Pin (6) and two washers (8)	Two new cotter pins (9)	a. Push in. b. Using multiple tongue and groove slip-joint pliers, bend ends back.	

NOTE

For swing cylinders equipped with cotter pins, skip step 71.

71. Swing frame (3) and pin (7)	Two new rings (10)		Using retaining ring pliers, put on.
---------------------------------	--------------------	--	--------------------------------------

NOTE

If installing left swing cylinder, skip steps 72 and 73.

72. Elbow (11)	Hose (12)	a. Takeoff tag. b. Uncap. c. Screw in and tighten using 11/16-inch and 7/8-inch open-end wrenches.	
----------------	-----------	--	--

BACKHOE SWING CYLINDERS - CONTINUED

LOCATION	ITEM	ACTION	REMARKS
73. Elbow (13)	Hose (14)	a. Take off tag. b. Uncap. c. Screw in and tighten using 7/8-inch and 1-inch open-end wrenches.	

NOTE

If installing right swing cylinder, skip steps 74 and 75.

74. Elbow (15)	Hose (16)	a. Take off tag. b. Uncap. c. Screw in and tighten using 7/8-inch and 11/16-inch open-end wrenches.	
----------------	-----------	---	--

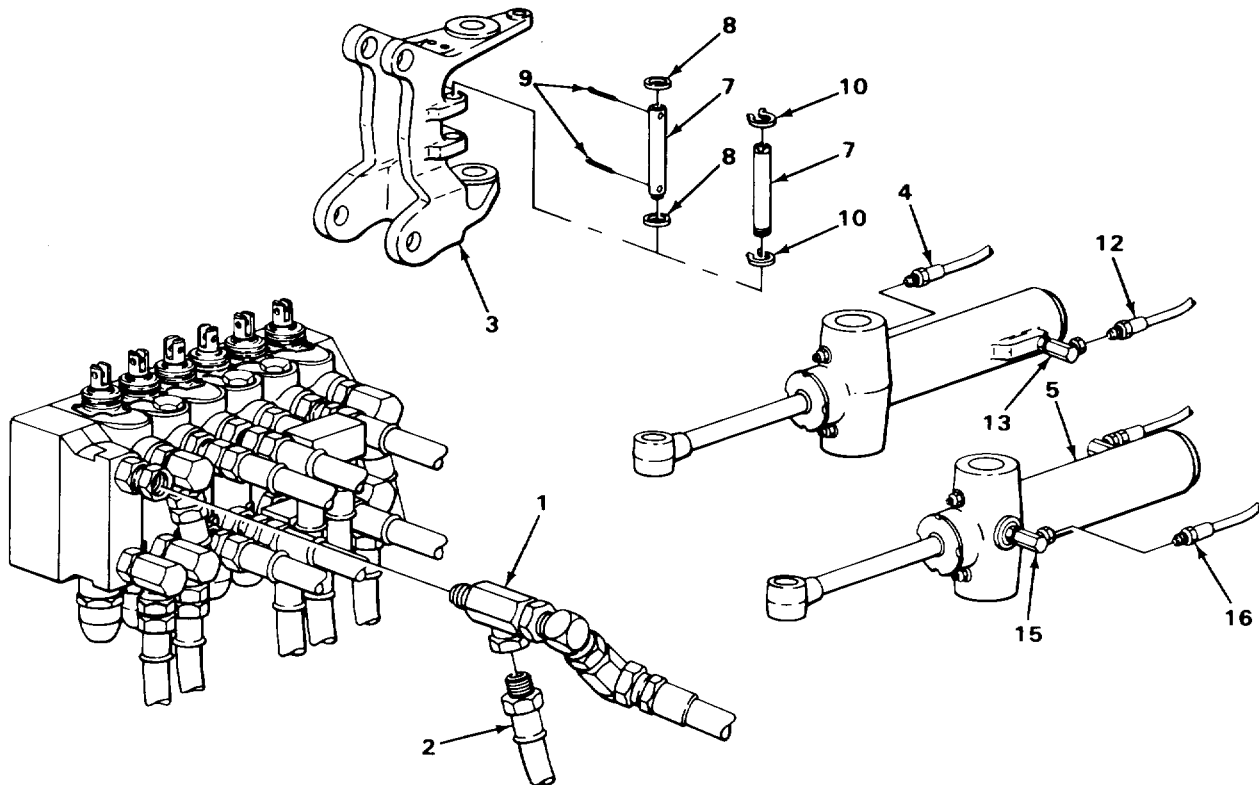

BACKHOE SWING CYLINDERS - CONTINUED

LOCATION	ITEM	ACTION	REMARKS
INSTALLATION - CONTINUED			
75.	Elbow (1)	Hose (2)	<ul style="list-style-type: none"> a. Take off tag. b. Uncap. c. Screw in and tighten using 7/8-inch and 1-inch open-end wrenches.
76.	Two handle mounts (3)	Two control levers (4)	Screw into position noted during removal.
77.	Two handle mounts (3) and control levers (4)	Two nuts (5)	Using 3/4-inch open-end wrench, tighten until seated against handle mounts (3).
78.	Two handle mounts (6)	Two four way levers (7)	Screw into positions noted during removal.
79.	Two handle mounts (6) and two four way levers (7)	Two nuts (8)	Using 15/16-inch open-end wrench, tighten until snug against handle mounts (6).
80.	Loader backhoes	Transmission	Check fluid level and add proper amount and grade (TM 5-2420-222-10).
81.		Engine	Start and run at high idle (TM 5-2420-222-10).
82.		Oil lines disassembled from backhoe control valve and swing cylinder	<ul style="list-style-type: none"> a. Operate backhoe controls (TM 5-2420-222-10) and check for leaks. b. If leaking at any connection, tighten using two 7/8-inch, 1-inch, 11/16-inch, 5/8-inch, 1 3/8-inch, 1 1/4-inch, 1 1/8-inch and 1 1/16-inch open-end wrenches. c. If leaking does not stop, shut down engine (TM 5-2420-222-10) and replace leaking connection packing or hose as outlined in this task. d. If found leaking, repeat steps 80 thru 82.
83.		Engine	If still running, shut down (TM 5-2420-222-10).

BACKHOE SWING CYLINDERS - CONTINUED

LOCATION	ITEM	ACTION	REMARKS
84. Two handle mounts (6) and two four way levers (7)	Two nuts (8)	Using 15/16-inch open-end wrench, loosen.	
85. Two handle mounts (6)	Two four way levers (7)	Noting relative positions, unscrew and take out.	
86. Two handle mounts (3) and control levers (4)	Two nuts (5)	Using 3/4-inch open-end wrench, loosen.	
87. Two handle mounts (3)	Two control levers (4)	Noting relative positions, unscrew and take out.	

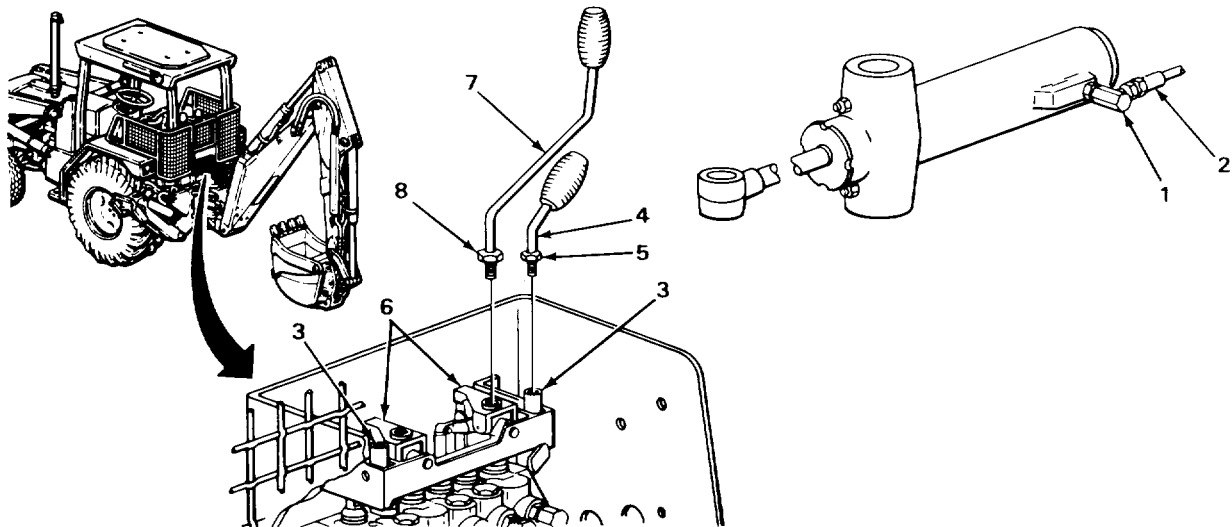

NOTE

FOLLOW-ON MAINTENANCE:

1. Install backhoe valve box cover (page 2-1157).
2. Install backhoe valve bottom cover (page 2-1154).

TASK ENDS HERE

TA243557

BACKHOE BUCKET CYLINDER

This task covers:

- | | |
|------------------------------|---|
| a. Removal (page 2-1727) | d. Inspection/Replacement (page 2-1733) |
| b. Disassembly (page 2-1730) | e. Assembly (page 2-1734) |
| c. Cleaning (page 2-1732) | f. Installation (page 2-1736) |
-

INITIAL SETUP:

Tools Materials/Parts

Driftpin, brass-tipped, 3/4-inch
 Hammer, cross-peen, 3-pound head
 Handle, ratchet, 1/2-inch drive
 Knife, pocket
 Lifting equipment, 200-pound capacity
 Pan, drain
 Screwdriver, flat-tip, 1/4-inch
 Socket, 1/2-inch drive, 3/4-inch
 Wrench, open-end, 7/16-inch
 Wrench, open-end, 3/4-inch
 Wrench, open-end, 1-inch
 (two required)
 Wrench, open-end, 11/16-inch

Nut, stop, pin screw
 Packing, adapter-to-cylinder
 Packing, connector-to-cylinder
 Rags, wiping (item 21, Appendix C)
 Solvent, drycleaning (item 28, Appendix C)
 Tags, wiping (item 30, Appendix C)

NOTE

The following part only applies to loader backhoes with linkage pins retained by cotter pins.

Pin, cotter, guide link pin (two required)

NOTE

The following tool only applies to loader backhoes with linkage pins retained by retaining rings.

Personnel Required

One

Pliers, retaining ring

NOTE

The following tools only apply to loader backhoes with linkage pins retained by cotter pins.

Pliers, slip-joint, multiple tongue and groove
 Punch, drive-pin, straight, 1/4-inch

BACKHOE BUCKET CYLINDER - CONTINUED

LOCATION	ITEM	ACTION	REMARKS
----------	------	--------	---------

REMOVAL

- | | | |
|---|-------------------------------|--|
| 1. Loader backhoe | Boom, dipperstick, and bucket | <ul style="list-style-type: none"> a. Extend as far as possible (TM 5-2420-220-10). b. Lower to ground until boom and dipperstick are horizontal (TM 5-2420-220-10). |
| 2. Hydraulic system Release pressure (page 2-1191). | | |

NOTE

Steps 3 and 4 only apply to loader backhoes with Serial Numbers 235786 thru 235999.

- | | | |
|----------------------|--------------------------------------|--|
| 3. Quick coupler (1) | Male nipple (2) with assembled parts | <ul style="list-style-type: none"> a. Place drain pan underneath. b. Pull off. c. Tag (page 2-137). |
|----------------------|--------------------------------------|--|

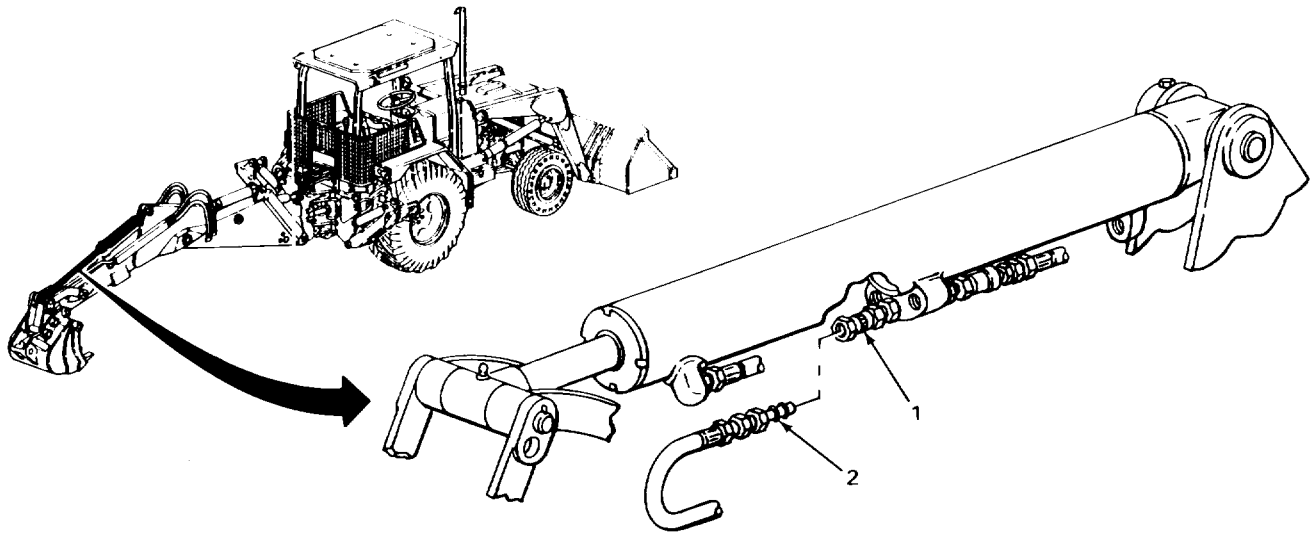

TA243558

BACKHOE BUCKET CYLINDER - CONTINUED

LOCATION	ITEM	ACTION	REMARKS
----------	------	--------	---------

REMOVAL - CONTINUED

- | | | | |
|--------------------|---|--|--|
| 4. Male nipple (1) | Quick coupler (2)
with assembled parts | a. Place drain pan underneath.
b. Pull off.
c. Tag (page 2-137). | |
|--------------------|---|--|--|

NOTE

Steps 5 thru 8 only apply to loader backhoes with Serial Numbers 319995 thru 342573.

- | | | | |
|--|-----------------|--|--|
| 5. Bucket cylinder
(3) and two
spacers (4) | Clamp (5) | Using 1/4-inch flat-tip screwdriver,
loosen and take off. | |
| 6. Bucket cylinder
(3) and tube (6) | Two spacers (4) | Take off. | |

WARNING

Be careful when draining hot fluids. Wear gloves to protect your hands from hot parts and fluids or severe burns could result.

- | | | | |
|-------------------------|---|--|--|
| 7. Male nipple (7) | Quick coupler (8)
with assembled parts | a. Place drain pan underneath.
b. Pull off.
c. Tag (page 2-137). | |
| 8. Quick
coupler (9) | Male nipple (10)
with assembled parts | a. Place drain pan underneath.
b. Pull off.
c. Tag (page 2-137). | |

WARNING

Some parts are heavy. Be careful when handling them. Lifting equipment is needed when parts weigh over 50 pounds (23 kg) for a single person lift, over 100 pounds (45 kg) for a two person lift, and over 150 pounds (68 kg) for a three or more person lift. Do not try to handle heavy parts without lifting equipment. Keep clear of heavy parts supported only by lifting equipment. Failure to observe this precaution could cause serious injury or death of personnel.

- | | | | |
|--|------------------------------|---|--|
| 9. Dipperstick (11)
and guide link (12) | Bucket cylinder
(3 or 13) | Using 200-pound capacity lifting equip-
ment, support. | |
|--|------------------------------|---|--|

BACKHOE BUCKET CYLINDER - CONTINUED

LOCATION	ITEM	ACTION	REMARKS
----------	------	--------	---------

NOTE

Some loader backhoes have linkage pins retained by retaining rings, some have pins retained by cotter pins. For loader backhoes equipped with retaining rings, skip steps 10 and 11.

- | | | |
|---|--------------------------|--|
| 10. Pin (14) and two special washers (15) | Two cotter pins (16) | <ul style="list-style-type: none"> a. Using multiple tongue and groove slip-joint pliers, straighten ends. b. Using 3-pound head cross-peen hammer and 1/4-inch straight drive-pin punch, drive out. c. Get rid of. |
| 11. Pin (14) and two coupler links (17) | Two special washers (15) | Take off. |

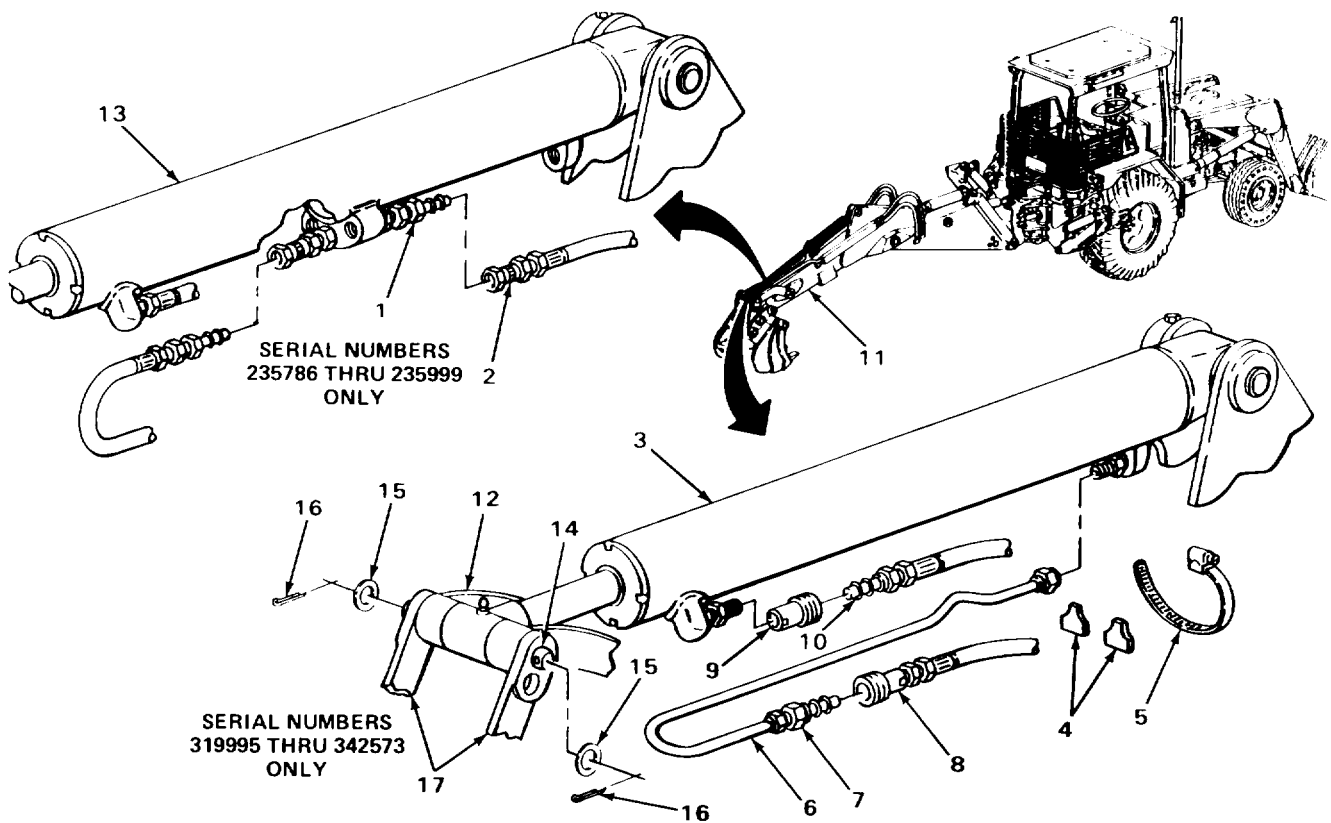

TA243559

BACKHOE BUCKET CYLINDER - CONTINUED

LOCATION	ITEM	ACTION	REMARKS
REMOVAL - CONTINUED			
<u>WARNING</u>			
Some parts are heavy. Be careful when handling them. Lifting equipment is needed when parts weigh over 50 pounds (23 kg) for a single person lift, over 100 pounds (45 kg) for a two person lift, and over 150 pounds (68 kg) for a three or more person lift. Do not try to handle heavy parts without lifting equipment. Keep clear of heavy parts supported only by lifting equipment. Failure to observe this precaution could cause serious injury or death of personnel.			
12.	Pin (1) and two coupler links (2)	Two rings (3)	On loader backhoes equipped with retaining rings, using retaining ring pliers, take off.
13.	Bucket cylinder (4), guide link (5), and two coupler links (2)	Pin (1 or 6)	Using 3-pound head cross-peen hammer and 3/4-inch brass-tipped driftpin, drive out.
14.	Dipperstick (7) and pin (8) wrench, unscrew and take apart.	Screw (9) and stop nut (10)	a. Using 3/4-inch, 1/2-inch drive socket, ratchet handle, and 3/4-inch open-end b. Get rid of stop nut (10).
15.	Dipperstick (7) and bucket cylinder (4)	Pin (8)	Using 3-pound head cross-peen hammer and 3/4-inch brass-tipped driftpin, drive out.
16.	Dipperstick (7) and guide link (5)	Bucket cylinder (4)	a. Using 200-pound capacity lifting equipment, take off. b. Take off 200-pound capacity lifting equipment.

DISASSEMBLY

NOTE

Steps 17 thru 22 only apply to loader backhoes with Serial Numbers 235786 thru 235999.

17.	Adapter (11)	Male nipple (12)	Using open-end wrenches, unscrew and take off.
18.	Bucket cylinder (4)	Adapter (11) with assembled packing (13)	a. Using open-end wrench, unscrew and take out. b. Plug cylinder (4) (page 2-137).

BACKHOE BUCKET CYLINDER - CONTINUED

LOCATION	ITEM	ACTION	REMARKS
19. Adapter (11)	Packing (13)	a. Using pocket knife, take off. b. Get rid of.	
20. Adapter (14) and take off.	Quick coupler (15)	Using 1-inch open-end wrench, unscrew	
21. Bucket cylinder (4)	Adapter (14) with assembled packing (16)	a. Using open-end wrench, unscrew and take out. b. Plug cylinder (4) (page 2-137).	
22. Adapter (14)	Packing (16)	a. Using pocket knife, take out. b. Get rid of.	

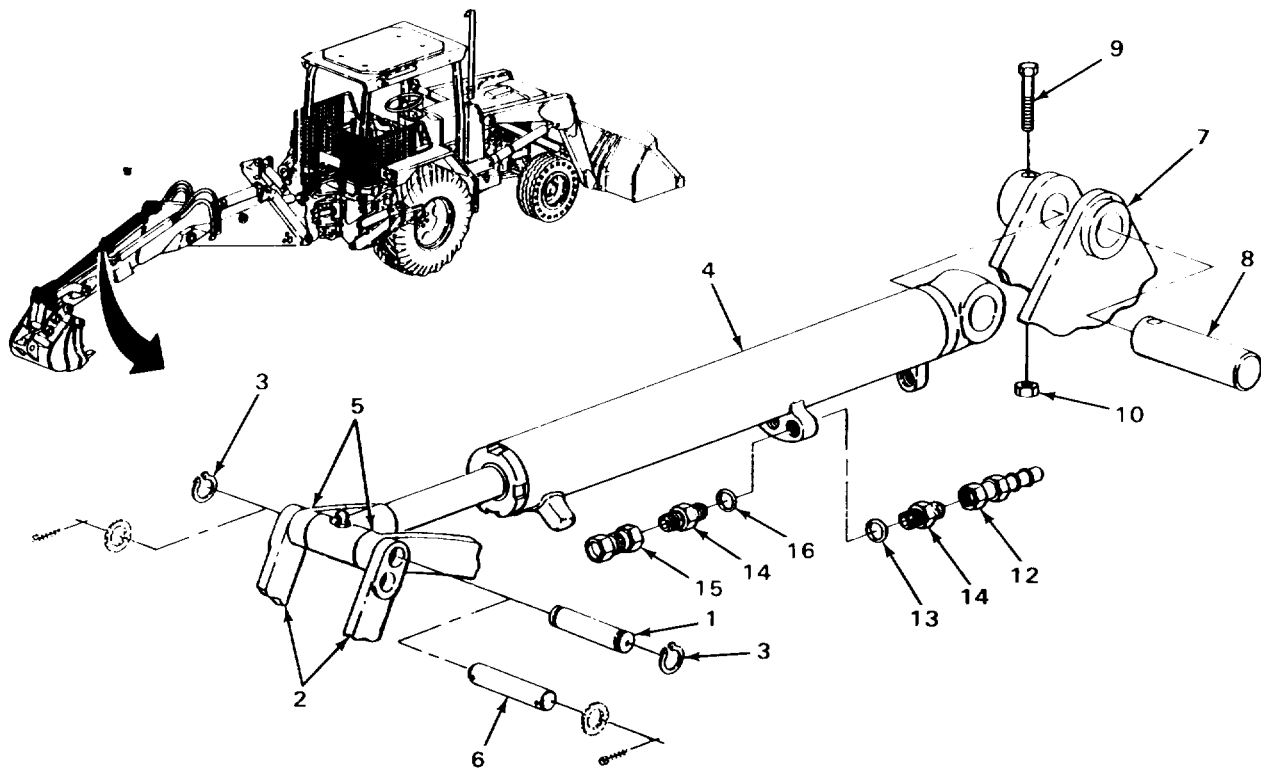

BACKHOE BUCKET CYLINDER - CONTINUED

LOCATION	ITEM	ACTION	REMARKS
DISASSEMBLY - CONTINUED			
NOTE			
Steps 23 thru 28 only apply to loader backhoes with Serial Numbers 319995 thru 342573.			
23.	Connector (1)	Tube (2)	Using two 1-inch open-end wrenches, unscrew and take off.
24.	Bucket cylinder (3) packing (4)	Connector (1) with assembled	a. Using 1-inch open-end wrench, unscrew and take out. b. Plug cylinder (3) (page 2-137).
25.	Connector (1)	Packing (4)	a. Using pocket knife, take off. b. Get rid of.
26.	Adapter (5)	Quick coupler (6)	Using 1 1/16-inch and 1-inch open-end wrenches, unscrew and take off.
27.	Bucket cylinder (3) packing (7)	Adapter (5)	a. Using 1-inch open-end wrench, unscrew and take out. b. Plug cylinder (3) (page 2-137).
28.	Adapter (5)	Packing (7)	a. Using pocket knife, take off. b. Get rid of.
29.	Bucket cylinder (3)	Two grease fittings (8 and 9)	Using 7/16-inch open-end wrench, unscrew and take out.

CLEANING

NOTE

For more information on how to clean parts, go to **General Maintenance Instructions (page 2-137)**.

WARNING

Drycleaning solvent P-D-680 is toxic and flammable. Wear protective goggles and gloves and use only in a well ventilated area. Avoid contact with skin, eyes, and clothes and don't breathe vapors. Do not use near open flame or excessive heat. The flashpoint is 100°F to 138°F (38° to 59°C). If you become dizzy while using cleaning solvent, get fresh air immediately and get medical aid. If contact with eyes is made, wash your eyes with water and get medical aid immediately.

BACKHOE BUCKET CYLINDER - CONTINUED

LOCATION	ITEM	ACTION	REMARKS
30. Bucket cylinder (3)		a. Using clean rags dampened in drycleaning solvent, wipe dry. b. Using clean, dry rags, wipe dry.	
31. All other metal parts		a. clean in drycleaning solvent. b. Using clean, dry rags, wipe dry.	

INSPECTION/REPLACEMENT

NOTE

For more information on how to inspect parts, go to **General Maintenance Instructions (page 2-137)**.

Replace defective parts as needed.

32.	Bucket cylinder (3)	Look for cracks and breaks.
33.	All threaded parts	Look for damaged threads.

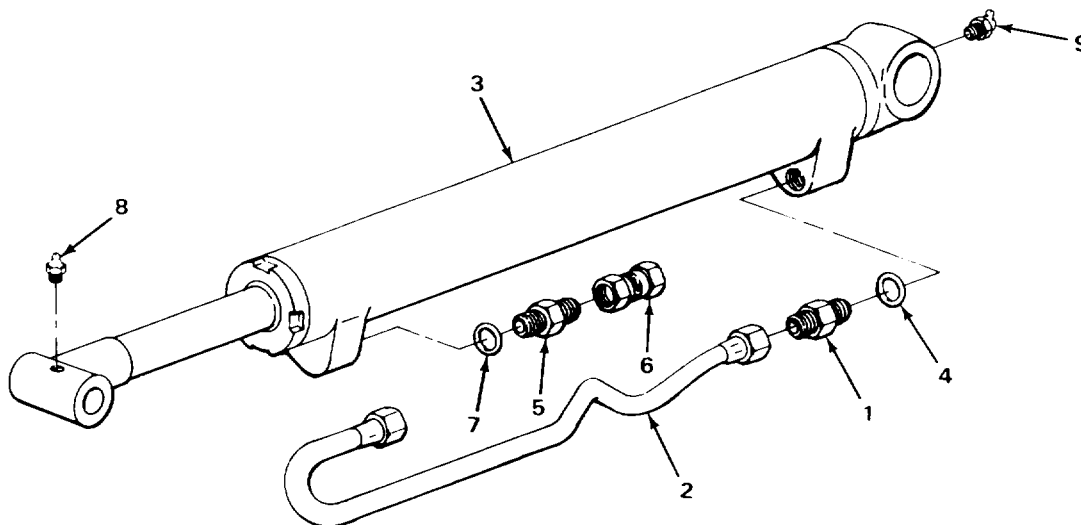

TA243561

BACKHOE BUCKET CYLINDER - CONTINUED

LOCATION	ITEM	ACTION	REMARKS
ASSEMBLY			
34.	Bucket cylinder (1 or 2)	Two grease fittings (3 and 4)	Screw in and tighten using 7/16-inch open-end wrench.
NOTE			
Steps 35 and 40 only apply to loader backhoes with Serial Numbers 319995 thru 342573.			
35.	Adapter (5)	New packing (6)	Place into position.
36.	Bucket cylinder (1)	Adapter (5) with assembled packing (6)	a. Unplug cylinder (1). b. Screw in and tighten using 1-inch open-end wrench.
37.	Adapter (5)	Quick coupler (7)	Screw on and tighten using 1 1/16-inch and 1-inch open-end wrenches.
38.	Connector (8)	New packing (9)	Place into position.
39.	Bucket cylinder (1)	Connector (8) with assembled packing (9)	a. Unplug cylinder (1). b. Screw in and tighten using 1-inch open-end wrench.
40.	Connector (8)	Tube (10)	Screw on and tighten using two 1-inch open-end wrenches.
NOTE			
Steps 41 thru 46 only apply to loader backhoes with Serial Numbers 235786 thru 235999.			
41.	Adapter (11)	New packing (12)	Place into position.
42.	Bucket cylinder (2)	Adapter(11) with assembled	a. Unplug cylinder(2). b. Screw in and tighten using open-end packing (12) wrench.
43.	Adapter (11)	Quick coupler (13)	Screw on and tighten using 1-inch open-end wrench.
44.	Adapter (14)	New packing (15)	Place into position.

BACKHOE BUCKET CYLINDER - CONTINUED

LOCATION	ITEM	ACTION	REMARKS
45. Bucket cylinder (2)	Adapter (14) with assembled	a. Unplug cylinder(2). b. Screw in and tighten using open-end packing (15) wrench.	
46. Adapter (14)	Male nipple (16)	Screw on and tighten using open-end wrench.	

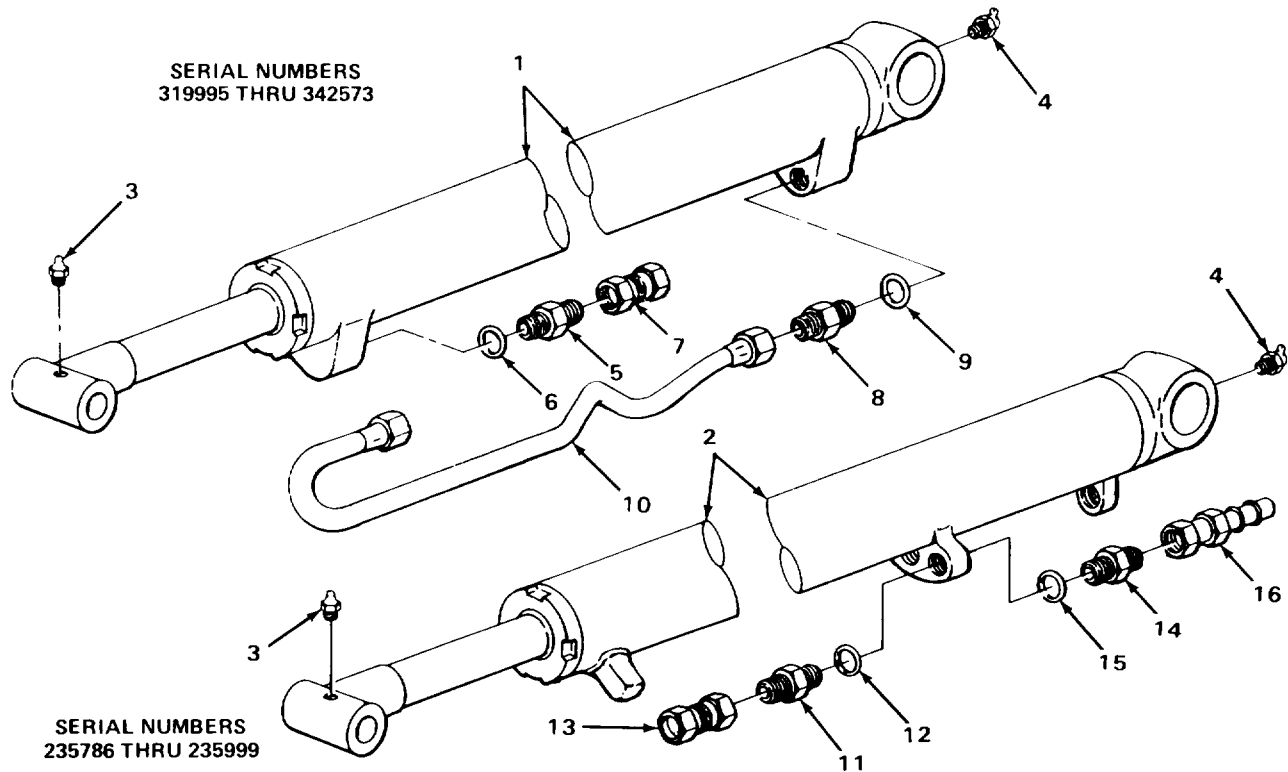

TA243562

BACKHOE BUCKET CYLINDER - CONTINUED

LOCATION	ITEM	ACTION	REMARKS
----------	------	--------	---------

INSTALLATION**WARNING**

Some parts are heavy. Be careful when handling them. Lifting equipment is needed when parts weigh over 50 pounds (23 kg) for a single person lift, over 100 pounds (45 kg) for a two person lift, and over 150 pounds (68 kg) for a three or more person lift. Do not try to handle heavy parts without lifting equipment. Keep clear of heavy parts supported only by lifting equipment. Failure to observe this precaution could cause serious injury or death of personnel.

47. Dipperstick (1) and guide link (2)	Bucket cylinder (3)	Using 200-pound capacity lifting equipment, place into position and support alining pin holes.
48. Dipperstick (1) and bucket	Pin (4)	Using 3-pound head cross-peen hammer, tap in alining pin holes. cylinder (3)
49.	Screw (5) and new stop nut (6)	Screw together and tighten using 3/4-inch, 1/2-inch drive socket, ratchet handle, and 3/4-inch open-end wrench.
50. Bucket cylinder (3), guide link (2), and two coupler links (7)	Pin (8 or 9)	Using 3-pound head cross-peen hammer, tap in.

NOTE

Some loader backhoes have linkage pins retained by retaining rings, some have pins retained by cotter pins. For loader backhoes equipped with cotter pins, skip step 51.

51. Pin (8) and two coupler links (7)	Two rings (10)	Using retaining ring pliers, put on.
---------------------------------------	----------------	--------------------------------------

NOTE

For loader backhoes equipped with retaining rings, skip steps 52 and 53.

52. Pin (9) and two coupler links (7)	Two special washers (11)	Place into position.
---------------------------------------	--------------------------	----------------------

BACKHOE BUCKET CYLINDER - CONTINUED

LOCATION	ITEM	ACTION	REMARKS
53. Pin (9) and two special washers (11)	Two new cotter pins (12)	a. Using 3-pound head cross-peen hammer, tap in. b. Using multiple tongue and groove slip-joint pliers, bend ends back.	
54. Dipperstick (1) and guide link (2)	Bucket cylinder (3)	Disconnect 200-pound capacity lifting equipment.	

NOTE

Steps 55 thru 58 only apply to loader backhoes with Serial Numbers 319995 thru 342573.

55. Quick coupler(13)	Male nipple (14) with assembled parts	a. Take off tags. b. Snap in.	
-----------------------	---------------------------------------	----------------------------------	--

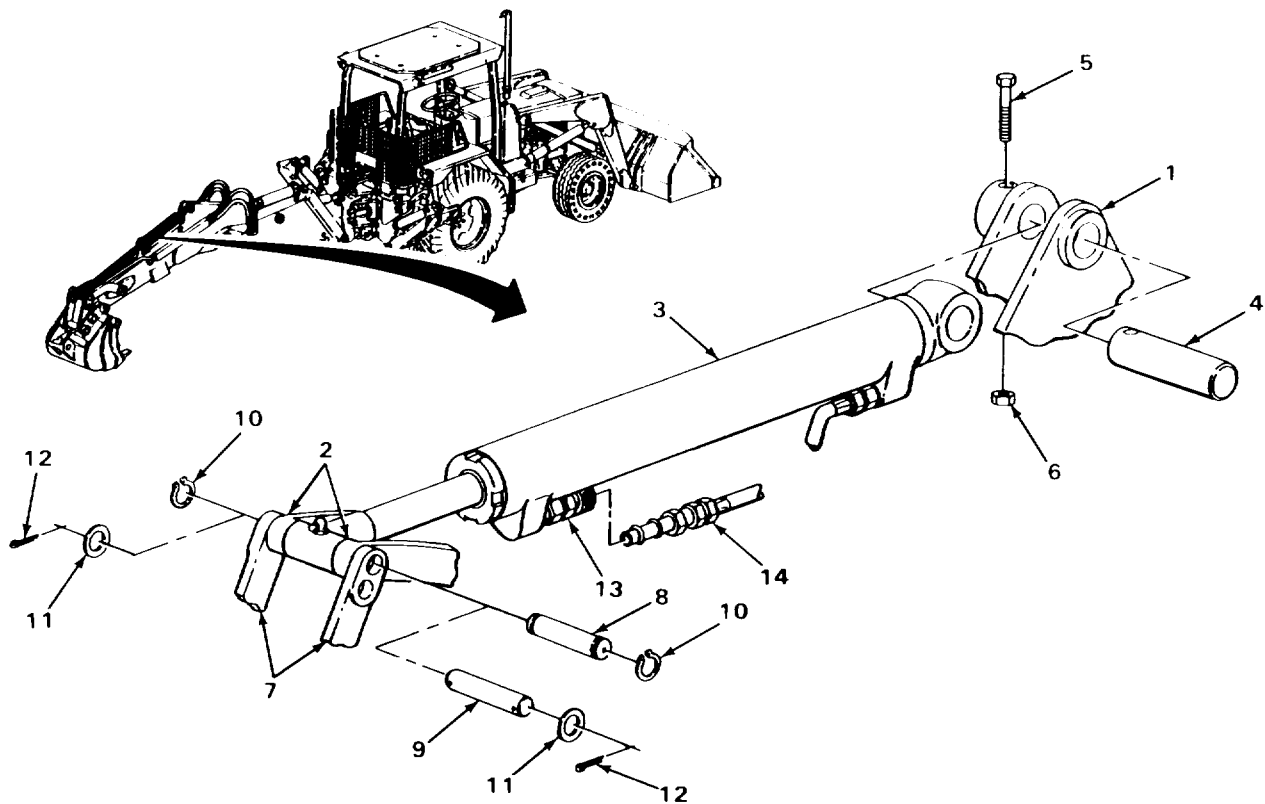

TA243563

BACKHOE BUCKET CYLINDER - CONTINUED

LOCATION	ITEM	ACTION	REMARKS
INSTALLATION - CONTINUED			
56.	Male nipple (1)	Quick coupler (2) with assembled parts	a. Take off tag. b. Snap on.
57.	Bucket cylinder (3) and tube (4)	Two spacers (5)	Place into position.
58.	Bucket cylinder (3) and two spacers (5)	Clamp (6)	Place into position.

NOTE

Steps 59 and 60 only apply to loader backhoes with Serial Numbers 235786 thru 235999.

59.	Male nipple (7)	Quick coupler (8) with assembled parts	a. Take off tag. b. Snap on.
60.	Quick coupler (9)	Male nipple (10) with assembled parts	a. Take off tag. b. Snap on.
61.	Loader backhoe	Transmission	Check fluid level and add proper amount and grade (TM 5-2420-222-10).
62.		Engine	Start and run at high idle (TM 5-2420-222-10).
63.		Oil lines and fittings dis- assembled from backhoe bucket cylinder	a. Operate dipperstick (TM 5-2420-222-10) and check for leaks. b. If leaking at any connection, tighten using 1 1/16-inch, and two 1-inch open-end wrenches. c. If leaking does not stop, shut down engine (TM 5-2420-222-10) and replace leaking connection packing or hoses as outlined in this task. d. If found leaking, repeat steps 61 thru 63.
64.		Engine	If still running, shut down (TM 5-2420-222-10).

BACKHOE BUCKET CYLINDER - CONTINUED

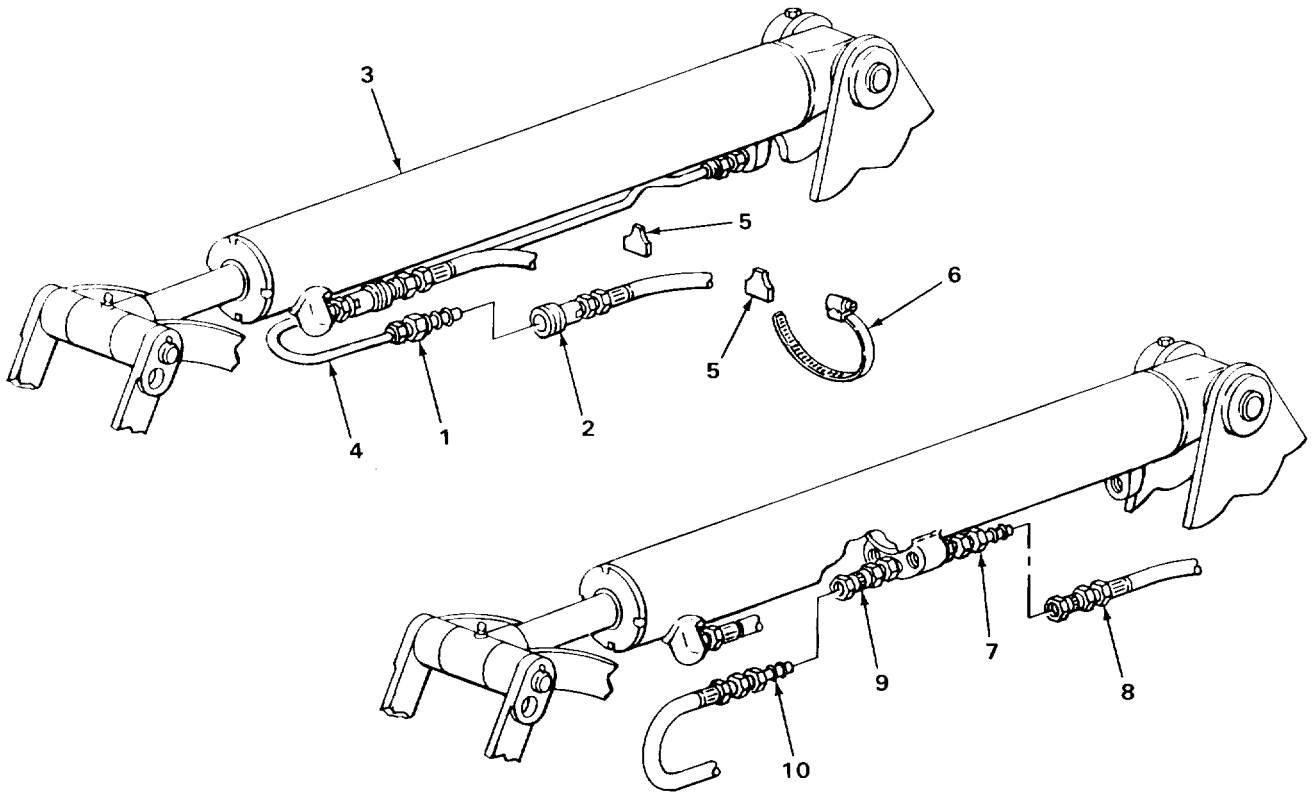

TASK ENDS HERE

TA243564

BACKHOE CROWD CYLINDER

This task covers:

- | | |
|------------------------------|---|
| a. Removal (page 2-1741) | d. Inspection/Replacement (page 2-1747) |
| b. Disassembly (page 2-1744) | e. Assembly (page 2-1748) |
| c. Cleaning (page 2-1746) | f. Installation (page 2-1749) |

INITIAL SETUP:

INITIAL SETUP

Tools

- Block, wood
- Driftpin, brass-tipped, 3/4-inch
- Hammer, ball-peen, 2-pound head
- Handle, ratchet, 1/2-inch drive
- Knife, pocket
- Lifting equipment, 200-pound capacity
- Pan, drain
- Screwdriver, flat-tip, 1/4-inch
- Socket, 1/2-inch drive, 3/4-inch
- Wrench, open-end, 7/16-inch
- Wrench, open-end, 3/4-inch
- Wrench, open-end, 1-inch
(two required)
- Wrench, open-end, 1 1/4-inch

Materials/Parts

- Locknut, pin screw
- Nut, stop, pin screw
- Packing, adapter-to-crowd cylinder
- Packing, connector-to-crowd cylinder
- Rags, wiping (item 21, Appendix C)
- Solvent, drycleaning (item 28, Appendix C)
- Tags, marking (item 28, Appendix C)

Personnel Required

One

LOCATION	ITEM	ACTION	REMARKS
----------	------	--------	---------

NOTE

Original equipment, crowd cylinders on loader backhoes with Serial Numbers 235786 thru 235999 are different from cylinders supplied on loader backhoes with Serial Numbers 319995 thru 342573. Old style cylinder assemblies are not available for replacement and must be replaced with new style when entire assembly is replaced. All necessary fittings, tubes, and hardware items required for installation are included with the new style crowd cylinder only when the old style crowd cylinder part number is ordered. Both styles are shown.

BACKHOE CROWD CYLINDER - CONTINUED

LOCATION	ITEM	ACTION	REMARKS
REMOVAL			
1. Loader backhoe	Boom, dipperstick, and bucket	a. Extend as far as possible (TM 5-2420-222-10). b. Lower to ground so that boom and dipperstick are horizontal (TM 5-2420-222-10).	
2.	Hydraulic system	Release pressure (page 2-1191).	

WARNING

Do not attempt to disconnect hydraulic lines and fittings while engine is running or before hydraulic system pressure has been released. When engine is running, hydraulic system is under pressure. Hydraulic system pressure should be 0 psi (0 kPa) before lines are disconnected. A line or fitting disconnected under pressure will blow off with a lot of force and could cause serious injury to personnel.

Be careful when draining hot fluids. Wear gloves to protect your hands from hot parts and fluids or severe burns could result.

NOTE

Steps 3 and 4 only apply to loader backhoes with old style crowd cylinders.

3. Adapter (1)	Hose (2)	a. Place drain pan underneath. b. Using open-end wrench, unscrew and take out. c. Cap hose (page 2-137). d. Tag (page 2-137).	
----------------	----------	--	--

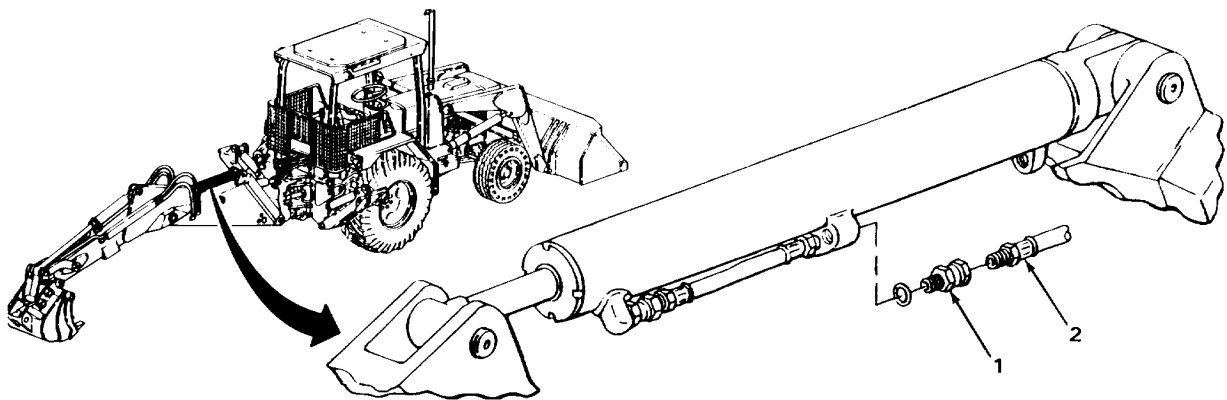

TA243565

BACKHOE CROWD CYLINDER - CONTINUED

LOCATION	ITEM	ACTION	REMARKS
----------	------	--------	---------

REMOVAL - CONTINUED**WARNING**

Do not attempt to disconnect hydraulic lines and fittings while engine is running or before hydraulic system pressure has been released. When engine is running, hydraulic system is under pressure. Hydraulic system pressure should be 0 psi (0 kPa) before lines are disconnected. A line or fitting disconnected under pressure will blow off with a lot of force and could cause serious injury to personnel.

Be careful when draining hot fluids. Wear gloves to protect your hands from hot parts and fluids or severe burns could result.

- | | | |
|----------------|----------|---|
| 4. Adapter (1) | Hose (2) | <ul style="list-style-type: none"> a. Using open-end wrench, unscrew and take out. b. Cap (page 2-137). c. Tag (page 2-137). |
|----------------|----------|---|

NOTE

Steps 5 and 8 only apply to loader backhoes with new style crowd cylinders.

- | | | |
|---|------------|--|
| 5. Tube (3) | Hose (4) | <ul style="list-style-type: none"> a. Place drain pan underneath. b. Using two 1-inch open-end wrenches, unscrew and take out. c. Cap (page 2-137). d. Tag (page 2-137). |
| 6. Adapter (5) | Hose (6) | <ul style="list-style-type: none"> a. Place drain pan underneath. b. Using two 1-inch open-end wrenches, unscrew and take off. c. Cap (page 2-137). d. Tag (page 2-137). |
| 7. Tube (3), hose (6), crowd cylinder (7), and spacer (8) | Clamp (9) | Using 1/4-inch flat-tip screwdriver, loosen and take off. |
| 8. Tube (3), hose (6), and crowd cylinder (7) | Spacer (8) | <ul style="list-style-type: none"> a. Note position for proper placement during installation. b. Take off. |

BACKHOE CROWD CYLINDER - CONTINUED

LOCATION	ITEM	ACTION	REMARKS
----------	------	--------	---------

WARNING

Some parts are heavy. Be careful when handling them. Lifting equipment is needed when parts weigh over 50 pounds (23 kg) for a single person lift, over 100 pounds (45 kg) for a two person lift, and over 150 pounds (68 kg) for a three or more person lift. Do not try to handle heavy parts without lifting equipment. Keep clear of heavy parts supported only by lifting equipment. Failure to observe this precaution could cause serious injury or death of personnel.

- | | | |
|---|--------------------------|--|
| 9. Dipperstick (10) and backhoe boom (11) | Crowd cylinder (7 or 12) | Using 200-pound capacity lifting equipment, support. |
|---|--------------------------|--|

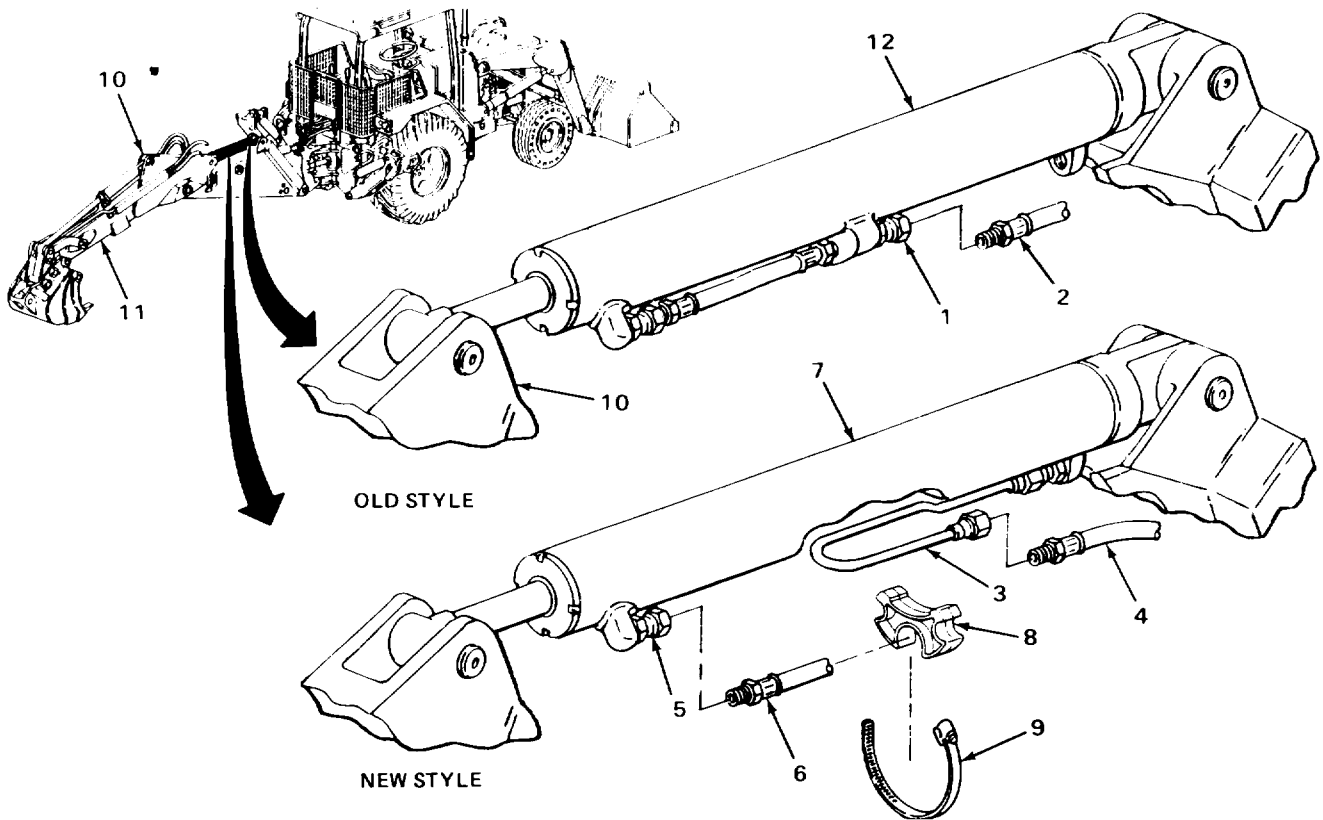

TA243566

BACKHOE CROWD CYLINDER - CONTINUED

LOCATION	ITEM	ACTION	REMARKS
----------	------	--------	---------

REMOVAL - CONTINUED**WARNING**

Some parts are heavy. Be careful when handling them. Lifting equipment is needed when parts weigh over 50 pounds (23 kg) for a single person lift, over 100 pounds (45 kg) for a two person lift, and over 150 pounds (68 kg) for a three or more person lift. Do not try to handle heavy parts without lifting equipment. Keep clear of heavy parts supported only by lifting equipment. Failure to observe this precaution could cause serious injury or death of personnel.

- | | | | |
|-----|--|----------------------------|--|
| 10. | Dipperstick (1) and pin (2) | Screw (3) and stop nut (4) | <ul style="list-style-type: none"> a. Using 3/4-inch, 1/2-inch drive socket, ratchet handle, and 3/4-inch open-end wrench, unscrew and take apart. b. Get rid of stop nut (4). |
| 11. | Dipperstick (1) and crowd cylinder (5 or 6) | Pin (2) | Using 2-pound head ball-peen hammer and 3/4-inch brass-tipped driftpin, drive out. |
| 12. | Backhoe boom (7) and pin (8) | Screw (9) and locknut (10) | <ul style="list-style-type: none"> a. Using 3/4-inch, 1/2-inch drive socket, ratchet handle, and 3/4-inch open-end wrench, unscrew and take apart. b. Get rid of locknut (10). |
| 13. | Backhoe boom (7) and crowd cylinder (5 or 6) | Pin (8) | Using 2-pound head ball-peen hammer and 3/4-inch brass-tipped driftpin, drive out. |
| 14. | Backhoe boom (7) and dipperstick (1) | Crow cylinder (5 or 6) | <ul style="list-style-type: none"> a. Using 200-pound capacity lifting equipment, take off. b. Take off 200-pound capacity lifting equipment. |

DISASSEMBLY

- | | | | |
|-----|-------------------------|--------------------------|--|
| 15. | Crowd cylinder (5 or 6) | Two grease fittings (11) | Using 7/16-inch open-end wrench, unscrew and take out. |
|-----|-------------------------|--------------------------|--|

NOTE

Steps 16 thru 19 only apply to loader backhoes with old style crowd cylinders.

- | | | | |
|-----|--------------------|--|---|
| 16. | Crowd cylinder (5) | Adapter (12) with assembled packing (13) | <ul style="list-style-type: none"> a. Using open-end wrench, unscrew and take out. b. Plug cylinder (5) (page 2-137). |
|-----|--------------------|--|---|

BACKHOE CROWD CYLINDER - CONTINUED

LOCATION	ITEM	ACTION	REMARKS
17. Adapter (12)	Packing (13)	a. Using pocket knife, take off. b. Get rid of.	
18. Crowd cylinder (5)	Adapter (14) with assembled packing (15)	a. Using open-end wrench, unscrew and take out. b. Plug cylinder (5) (page 2-137).	
19. Adapter (14)	Packing (15)	a. Using pocket knife, take off. b. Get rid of.	

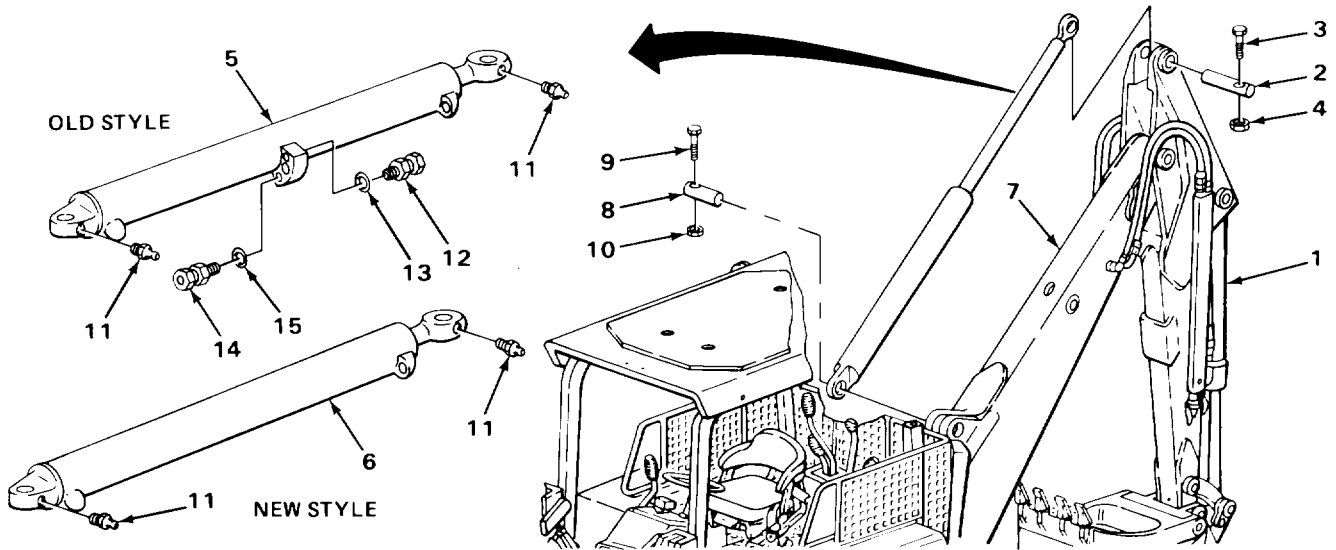

TA243567

BACKHOE CROWD CYLINDER - CONTINUED

LOCATION	ITEM	ACTION	REMARKS
DISASSEMBLY			
NOTE			
Step 20 thru 25 only apply to loader backhoes with new style crowd cylinders.			
20.	Connector (1)	Tube (2)	<ul style="list-style-type: none"> a. Note position for proper placement during assembly. b. Using 1-inch and 1 1/4-inch open-end wrenches, unscrew and take off.
21.	Crowd cylinder (3)	Connector (1) with assembled packing (4)	<ul style="list-style-type: none"> a. Using 1 1/4-inch open-end wrench, unscrew and take out. b. Plug cylinder (3) (page 2-137).
22.	Connector (1)	Packing (4)	<ul style="list-style-type: none"> a. Using pocket knife, take off. b. Get rid of.
23.	Crowd cylinder(3)	Adapter (5) with assembled packing (6)	<ul style="list-style-type: none"> a. Using 1 1/4-inch open-end wrench, unscrew and take out. b. Plug cylinder (3) (page 2-137).
24.	Adapter (5)	Packing (6)	<ul style="list-style-type: none"> a. Using pocket knife, take off. b. Get rid of.

CLEANING**NOTE**

For more information on how to clean parts, go to **General Maintenance Instructions (page 2-137)**.

WARNING

Drycleaning solvent P-D-680 is toxic and flammable. Wear protective goggles and gloves and use only in a well ventilated area. Avoid contact with skin, eyes, and clothes and don't breathe vapors. Do not use near open flame or excessive heat. The flashpoint is 100°F to 138°F (38° to 59°C). If you become dizzy while using cleaning solvent, get fresh air immediately and get medical aid. If contact with eyes is made, wash your eyes with water and get medical aid immediately.

BACKHOE CROWD CYLINDER - CONTINUED

LOCATION	ITEM	ACTION	REMARKS
25.	Crowd cylinder (3 or 7)	a. Using clean rags dampened with dry-cleaning solvent, wipe clean. b. Using clean, dry rags, wipe dry.	
26.	All other metal parts	a. Clean in drycleaning solvent. b. Using clean, dry rags, wipe dry.	

INSPECTION/REPLACEMENT

NOTE

For more information on how to inspect parts, go to **General Maintenance Instructions (page 2-137)**.

Replace defective parts as needed.

27.	Crowd cylinder (3 or 7)	Look for cracks and breaks.
28.	All threaded parts	Look for damaged threads.

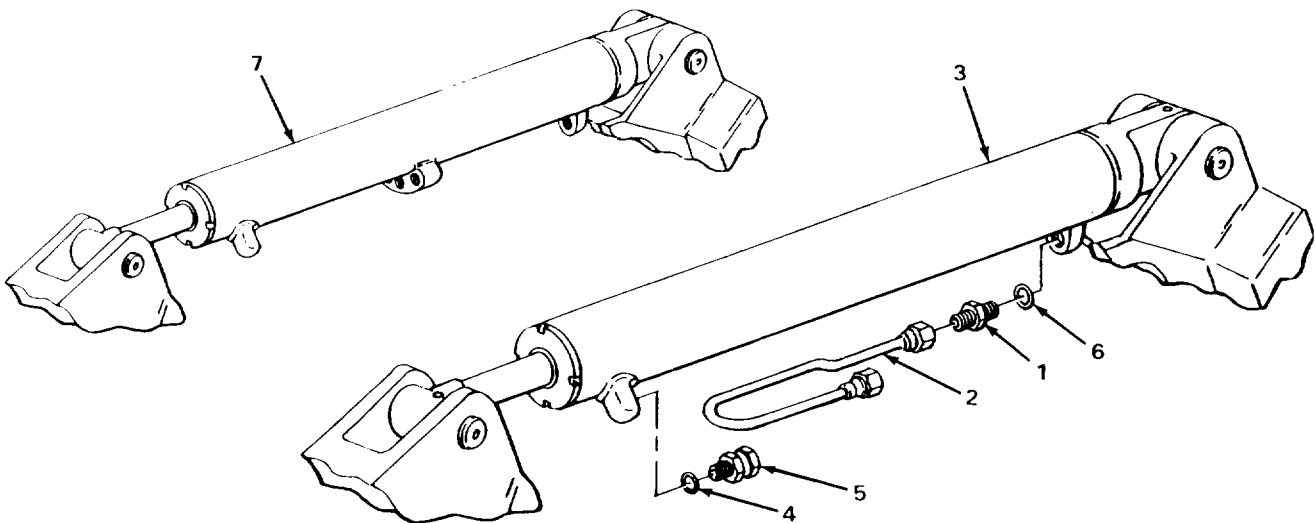

TA243568

BACKHOE CROWD CYLINDER - CONTINUED

LOCATION	ITEM	ACTION	REMARKS
ASSEMBLY			
NOTE			
Steps 29 thru 32 only apply to loader backhoes with old style crowd cylinders.			
29. Adapter (1)	New packing (2)	Place in position.	
30. Crowd cylinder (3)	Adapter (1) with assembled packing (2)	a. Unplug cylinder(3). b. Screw in and tighten using open-end wrench.	
31. Adapter (4)	New packing (5)	Place in position.	
32. Crowd cylinder (3)	Adapter (4) with assembled packing (5)	a. Unplug cylinder (3). b. Screw in and tighten using open-end wrench.	
NOTE			
Steps 33 thru 36 only apply to loader backhoes with new style crowd cylinders.			
33. Adapter (6)	New packing (7)	Place in position.	
34. Crowd cylinder (8)	Adapter (6) with assembled packing (7)	a. Unplug cylinder (8). b. Screw in and tighten using open-end wrench.	
35. Connector (9)	New packing (10)	Place in position.	
36. Crowd cylinder (8)	Connector (9)	a. Unplug cylinder (8). b. Screw in and tighten using 1 1/4-inch open-end wrench.	
37. Connector (9)	Tube (11)	Screw on and tighten to same relative position as noted during disassembly using 1-inch and 1 1/4-inch open-end wrenches.	
38. Crowd cylinder (3 or 8)	Two grease fittings (12)	Screw in and tighten using 7/16-inch open-end wrench.	

BACKHOE CROWD CYLINDER - CONTINUED

LOCATION	ITEM	ACTION	REMARKS
----------	------	--------	---------

INSTALLATION

WARNING

Some parts are heavy. Be careful when handling them. Lifting equipment is needed when parts weigh over 50 pounds (23 kg) for a single person lift, over 100 pounds (45 kg) for a two person lift, and over 150 pounds (68 kg) for a three or more person lift. Do not try to handle heavy parts without lifting equipment. Keep clear of heavy parts supported only by lifting equipment. Failure to observe this precaution could cause serious injury or death of personnel.

- | | | |
|--|-------------------------|--|
| 39. Dipperstick (13) and backhoe boom (14) | Crowd cylinder (3 or 8) | Using 200-pound capacity lifting equipment, place into position and support. |
|--|-------------------------|--|

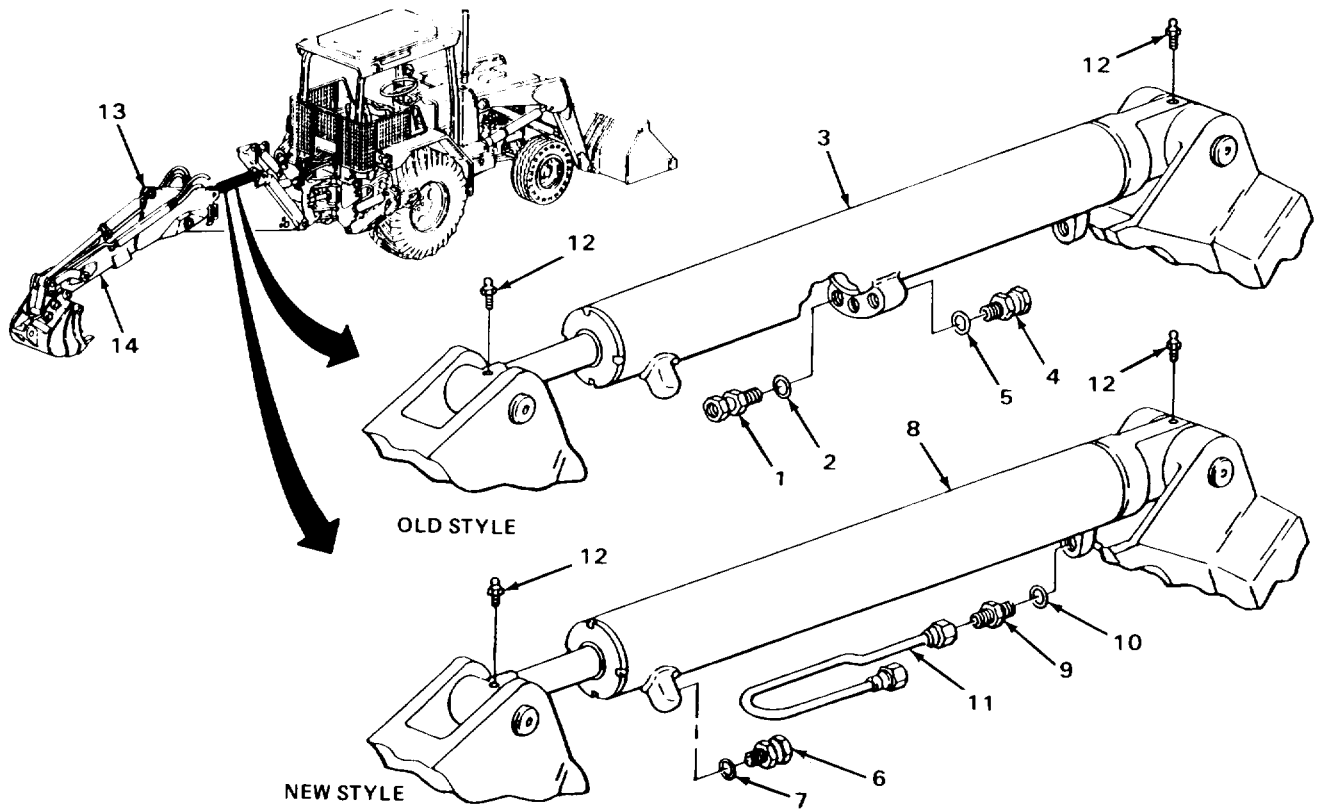

TA243569

BACKHOE CROWD CYLINDER - CONTINUED

LOCATION	ITEM	ACTION	REMARKS
----------	------	--------	---------

INSTALLATION - CONTINUED**WARNING**

Some parts are heavy. Be careful when handling them. Lifting equipment is needed when parts weigh over 50 pounds (23 kg) for a single person lift, over 100 pounds (45 kg) for a two person lift, and over 150 pounds (68 kg) for a three or more person lift. Do not try to handle heavy parts without lifting equipment. Keep clear of heavy parts supported only by lifting equipment. Failure to observe this precaution could cause serious injury or death of personnel.

40. Backhoe boom (1) and crowd cylinder (2 or 3)	Pin (4)	Using 2-pound head ball-peen hammer, tap in.
41. Backhoe boom (1) and pin (4)	Screw (5) and new locknut (6)	Screw together and tighten using 3/4-inch, 1/2-inch drive socket, ratchet handle, and 3/4-inch open-end wrench.
42. Dipperstick (7) and crowd cylinder (2 or 3)	Pin (8)	Using 2-pound head ball-peen hammer, tap in.
43. Dipperstick (7) and pin (8)	Screw (9) and new stop nut (10)	Screw together and tighten using 3/4-inch, 1/2-inch drive socket, ratchet handle, and 3/4-inch open-end wrench.
44. Backhoe boom (1) and dipperstick (7)	Crowd cylinder (2 or 3)	Disconnect 200-pound capacity lifting equipment.

NOTE

Steps 45 and 46 only apply to loader backhoes with old style crowd cylinders.

45. Adapter(11)	Hose(12)	a. Takeoff tag. b. Uncap. c. Screw in and tighten using open-end wrench.
46. Adapter (13)	Hose (14)	a. Take off tag. b. Uncap. c. Screw in and tighten using open-end wrench.

BACKHOE CROWD CYLINDER - CONTINUED

LOCATION	ITEM	ACTION	REMARKS
NOTE			
Steps 47 and 50 only apply to loader backhoes with new style crowd cylinders.			
47. Adapter(15)	Hose (16)	a. Take off tag. b. Uncap. c. Screw in and tighten using two 1-inch open-end wrenches.	
48. Tube (17)	Hose (18)	a. Take off tag. b. Uncap. c. Screw in and tighten using two 1-inch open-end wrenches.	
49. Tube (17), hose (16), and crowd cylinder (3)	Spacer (19) removal.		Place into position as noted during
50. Crowd cylinder (3), spacer (19), tube (17), and hose (16)	Clamp (20)		Place in position and tighten using 1/4-inch flat-tip screwdriver.
51. Loader backhoe	Transmission		Check fluid level and add proper amount and grade (TM 5-2420-22-10).
52.	Engine		Start and run at high idle (TM 5-2420-222-10).

2-1751

BACKHOE CROWD CYLINDER - CONTINUED

LOCATION	ITEM	ACTION	REMARKS
INSTALLATION - CONTINUED			
53.	Oil lines and fitting disassembled from backhoe crowd cylinder	<ul style="list-style-type: none"> a. Operate backhoe boom (TM 5-2420-222-10) and check for leaks. b. If leaking at any connection, tighten using two 1-inch and 1 1/4-inch open-end wrenches. c. If leaking does not stop, shut down engine (TM 5-2420-222-10) and replace leaking connection packings as outlined in this task. d. If found leaking, repeat steps 51 thru 53. 	
54.	Engine		If still running, shut down (TM 5-2420-222-10).

TASK ENDS HERE

BACKHOE STABILIZER CYLINDERS

This task covers:

- | | |
|---|---|
| <ul style="list-style-type: none"> a. Removal (page 2-1753) b. Disassembly (page 2-1755) c. Cleaning (page 2-1756) | <ul style="list-style-type: none"> d. Inspection/Replacement (page 2-1756) e. Assembly (page 2-1757) f. Installation (page 2-1758) |
|---|---|

INITIAL SETUP

Tools

- Block, wood
- Driftpin, brass-tipped, 3/4-inch
- Hammer, cross-peen, 3-pound head
- Handle, ratchet, 1/2-inch drive
- Lifting equipment, 100-pound capacity
- Knife, pocket
- Pan, drain
- Socket, 1/2-inch drive, 3/4-inch
- Wrench, open-end, 11/16-inch
- Wrench, open-end, 7/8-inch (two required)
- Wrench, open-end, 3/4-inch

Materials/Parts

- Locknut, pin screw (two required)
- Packing, elbow to cylinder
- Packing, adapter-to-cylinder (two required)
- Rags, wiping (item 21, Appendix C)
- Solvent, drycleaning (item 28, Appendix C)
- Tags, marking (item 30, Appendix C)

BACKHOE STABILIZER CYLINDER CONTINUED

INITIAL SETUP - CONTINUED

Personnel Required

One

Equipment Condition

Hydraulic system pressure released
(page 2-1191)

LOCATION	ITEM	ACTION	REMARKS
----------	------	--------	---------

NOTE

Both stabilizer cylinders are maintained the same way. Right cylinder is shown. Repeat procedures for left cylinder as needed.

REMOVAL

WARNING

Do not attempt to disconnect hydraulic lines and fittings while engine is running or before hydraulic system pressure has been released. When engine is running, hydraulic system is under pressure. Hydraulic system pressure should be 0 psi (0 kPa) before lines are disconnected. A line or fitting disconnected under pressure will blow off with a lot of force and could cause serious injury to personnel.

Be careful when draining hot fluids. Wear gloves to protect your hands from hot parts and fluids or severe burns could result.

- | | | |
|----------------|--------------------------|--|
| 1. Adapter (1) | Hose (2) and packing (3) | <ul style="list-style-type: none"> a. Place drain pan underneath. b. Using 11/16-inch and 7/8-inch open-end wrenches, unscrew and take off. c. Cap (page 2-137). d. Tag (page 2-137). e. Discard packing. |
|----------------|--------------------------|--|

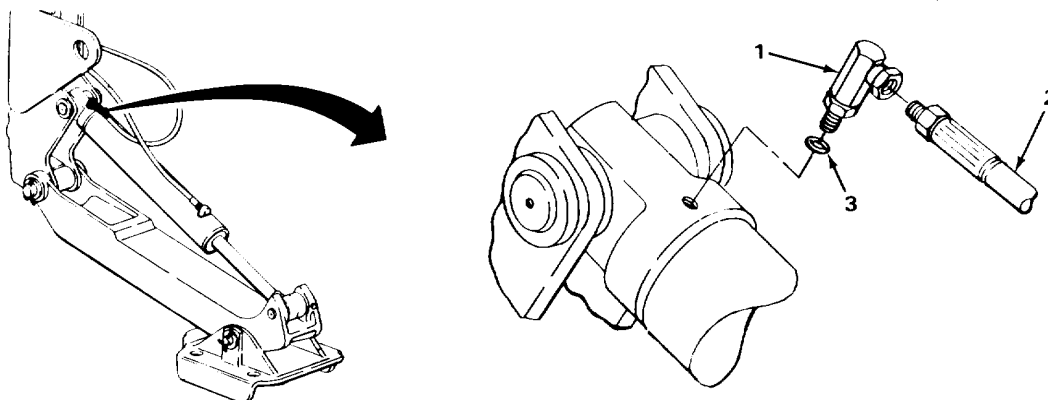

TA243571

BACKHOE STABILIZER CYLINDERS - CONTINUED

LOCATION	ITEM	ACTION	REMARKS
----------	------	--------	---------

REMOVAL - CONTINUED

WARNING

Do not attempt to disconnect hydraulic lines and fittings while engine is running or before hydraulic system pressure has been released. When engine is running, hydraulic system is under pressure. Hydraulic system pressure should be 0 psi (0 kPa) before lines are disconnected. A line or fitting disconnected under pressure will blow off with a lot of force and could cause serious injury to personnel.

Be careful when draining hot fluids. Wear gloves to protect your hands from hot parts and fluids or severe burns could result.

- | | | |
|----------------|-----------------------------|--|
| 2. Adapter (1) | Hose (2) and
packing (3) | <ul style="list-style-type: none"> a. Place drain pan underneath. b. Using 11/16-inch and 7/8-inch open-end wrenches, unscrew and take off. c. Cap (page 2-137). d. Tag (page 2-137). e. Discard packing. |
|----------------|-----------------------------|--|

WARNING

Some parts are heavy. Be careful when handling them. Lifting equipment is needed when parts weigh over 50 pounds (23 kg) for a single person lift, over 100 pounds (45 kg) for a two person lift, and over 150 pounds (68 kg) for a three or more person lift. Do not try to handle heavy parts without lifting equipment. Keep clear of heavy parts supported only by lifting equipment. Failure to observe this precaution could cause serious injury or death of personnel.

- | | | |
|---|--------------------------------|--|
| 3. Main frame (4)
and stabilizer (5) | Stabilizer
cylinder (6) | Using 100-pound capacity lifting equipment, support. |
| 4. Stabilizer (5)
and pin (7) | Screw (8) and
locknut (9) | <ul style="list-style-type: none"> a. Using 3/4-inch, 1/2-inch drive socket, ratchet handle, and 3/4-inch open-end wrench, unscrew and take apart. b. Get rid of locknut (9). |
| 5. Stabilizer (5)
and stabilizer
cylinder (6) | Pin (7) | Using 3-pound head cross-peen hammer and 3/4-inch brass-tipped driftpin, drive out. |
| 6. Main frame (4)
and pin (10) | Screw (11) and
locknut (12) | <ul style="list-style-type: none"> a. Using 3/4-inch, 1/2-inch drive socket, ratchet handle, and 3/4-inch open-end wrench, unscrew and take apart. b. Get rid of locknut (12). |

BACKHOE STABILIZER CYLINDERS - CONTINUED

LOCATION	ITEM	ACTION	REMARKS
7. Main frame (4) and stabilizer cylinder (5)	Pin (10)		Using 3-pound head cross-peen hammer and 3/4-inch brass-tipped driftpin, drive out.
8. Main frame (4) and stabilizer (5)	Stabilizer cylinder (6)	a. Using 100-pound capacity lifting equipment, take off. b. Take off 100-pound capacity lifting equipment.	

DISASSEMBLY

9. Stabilizer cylinder (6) and adapter (13)	Nut (14)	Using two 7/8-inch open-end wrenches, loosen.
---	----------	---

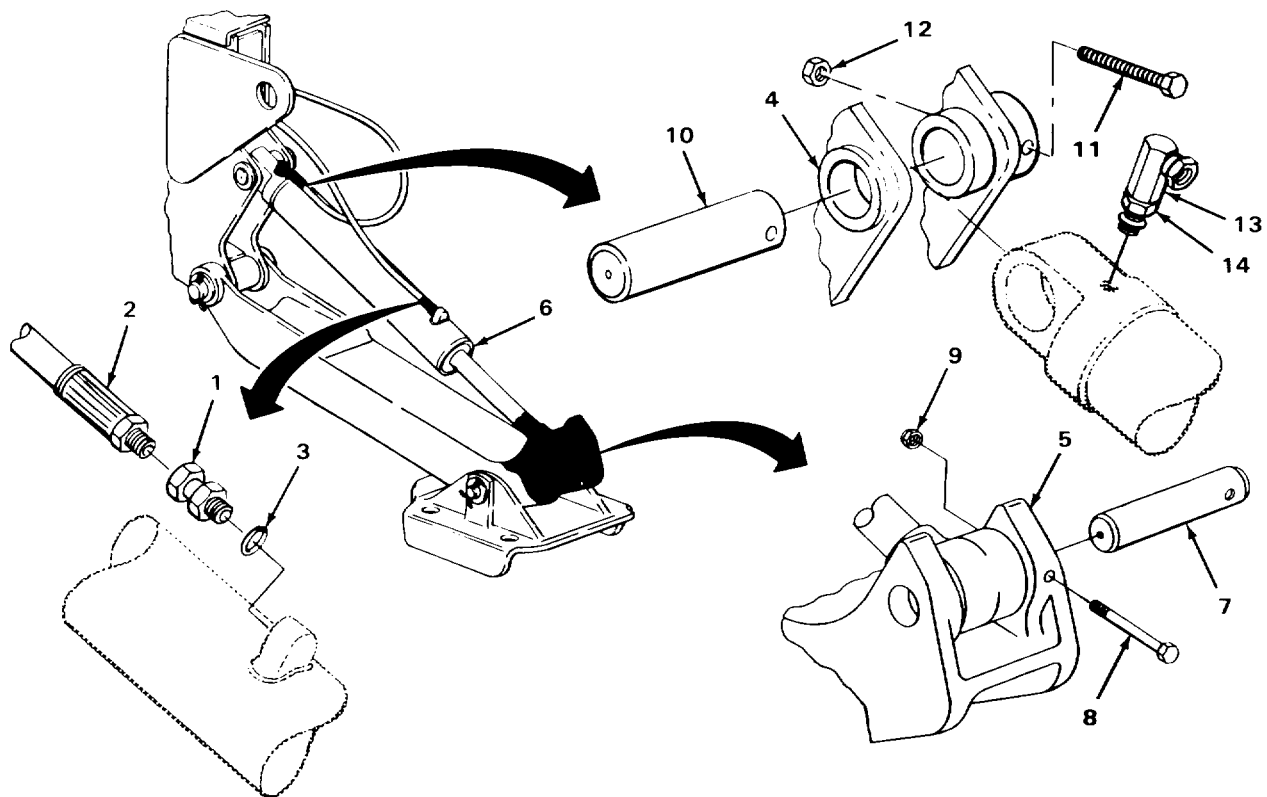

TA243572

BACKHOE STABILIZER CYLINDERS - CONTINUED

LOCATION	ITEM	ACTION	REMARKS
DISASSEMBLY - CONTINUED			
10.	Stabilizer cylinder (1)	Adapter (2) with assembled parts	<ol style="list-style-type: none"> Note position for proper placement during assembly. Using 7/8-inch open-end wrench, unscrew and take off. Plug cylinder (1) (page 2-137).
11.	Adapter(2)	Packing (3)	<ol style="list-style-type: none"> Using pocket knife, take out. Get rid of.
12.	Stabilizer cylinder (1)	Adapter (4) with assembled parts	<ol style="list-style-type: none"> Using 7/8-inch open-end wrench, unscrew and take off. Plug cylinder (1) (page 2-137).
13.	Adapter (4)	Packing (5)	<ol style="list-style-type: none"> Using pocket knife, take out. Get rid of.

CLEANING

NOTE

For more information on how to clean parts, go to **General Maintenance Instructions (page 2-137)**.

WARNING

Drycleaning solvent P-D-680 is toxic and flammable. Wear protective goggles and gloves and use only in a well ventilated area. Avoid contact with skin, eyes, and clothes and don't breathe vapors. Do not use near open flame or excessive heat. The flashpoint is 100°F to 138°F (38° to 59°C). If you become dizzy while using cleaning solvent, get fresh air immediately and get medical aid. If contact with eyes is made, wash your eyes with water and get medical aid immediately.

14.	Stabilizer cylinder (1)		<ol style="list-style-type: none"> Using clean rags dampened in dry-cleaning solvent, wipe clean. Using clean, dry rags, wipe dry.
15.	All other metal parts		<ol style="list-style-type: none"> Clean in drycleaning solvent. Using clean, dry rags, wipe dry.

INSPECTION/REPLACEMENT

NOTE

For more information on how to inspect parts, go to **General Maintenance Instructions (page 2-137)**.

BACKHOE STABILIZER CYLINDERS - CONTINUED

LOCATION	ITEM	ACTION	REMARKS
----------	------	--------	---------

NOTE

Replace defective parts as needed.

16.	Stabilizer cylinder (1)	Look for cracks and breaks.	
17.	All threaded parts	Look for damaged threads.	
ASSEMBLY			
18. Adapter (4)	New packing (5)	Place in position.	
19. Stabilizer cylinder (1)	Adapter (4) with assembled parts	a. Unplug cylinder (1). b. Screw in and tighten using 7/8-inch open-end wrench.	
20. Adapter (2)	Nut (6)	Screw on all the way.	
21.	New packing (3)	Place in position.	
22. Stabilizer cylinder (1)	Adapter (2)	a. Unplug cylinder (1). b. Screw into same relative position noted during disassembly using 7/8-inch open-end wrench.	
23. Stabilizer cylinder (1) and adapter (2)	Nut (6)	Using two 7/8-inch open-end wrenches tighten until seated against cylinder (1).	

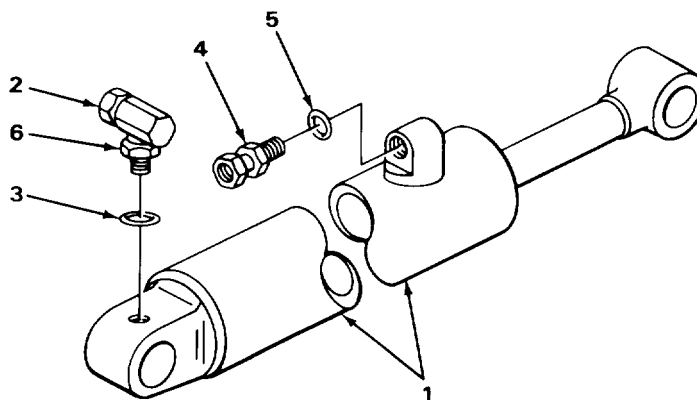

TA243573

BACKHOE STABILIZER CYLINDERS - CONTINUED

LOCATION	ITEM	ACTION	REMARKS
INSTALLATION			
WARNING			
Some parts are heavy. Be careful when handling them. Lifting equipment is needed when parts weigh over 50 pounds (23 kg) for a single person lift, over 100 pounds (45 kg) for a two person lift, and over 150 pounds (68 kg) for a three or more person lift. Do not try to handle heavy parts without lifting equipment. Keep clear of heavy parts supported only by lifting equipment. Failure to observe this precaution could cause serious injury or death of personnel.			
24. Stabilizer (1) and main frame (2)	Stabilizer cylinder (3)		Using 100-pound capacity lifting equipment place into position and support.
25. Main frame (2) and stabilizer cylinder (3)	Pin (4)	a. Aline holes in pin (4) and main frame (2). b. Using 3-pound head cross-peen hammer, tap into position.	
26. Main frame (2) and pin (4)	Screw (5) and new locknut (6)		Screw together and tighten using 3/4-inch, 1/2-inch drive socket, ratchet handle, and 3/4-inch open-end wrench.
27. Stabilizer (1) and stabilizer cylinder (3)	Pin (7)	a. Aline hole in pin (7) and stabilizer (1). b. Using 3-pound head cross-peen hammer, tap into position.	
28. Stabilizer (1) and pin (7)	Screw (8) and new locknut (9)		Screw together and tighten using 3/4-inch, 1/2-inch drive socket, ratchet handle, and 3/4-inch open-end wrench.
29. Stabilizer (1) and main frame (2)	Stabilizer cylinder (3)		Take off 100-pound capacity lifting equipment.
30. Adapter (10)	Hose (11)	a. Take off tag. b. Uncap. c. Screw in and tighten using 11/16-inch and 7/8-inch open-end wrenches.	
31. Adapter(12)	Hose (13)	a. Take off tag. b. Uncap. c. Screw in and tighten using 11/16-inch and 7/8-inch open-end wrenches.	
32. Loader backhoe	Transmission		Check fluid level and add proper amount and grade (TM 5-2420-222-10).

BACKHOE STABILIZER CYLINDERS - CONTINUED

LOCATION	ITEM	ACTION	REMARKS
33. Loader backhoe	Engine	Start and run at high idle (TM 5-2420-222-10).	
34.	Stabilizer cylinder (3), adapter (10), hose (11), adapter (12) and hose (13)	<ul style="list-style-type: none"> a. Operate stabilizer (TM 5-2420-222-10) and check for leaks. b. If leaking at any connection tighten using two 7/8-inch, and 11/16-inch open-end wrenches. c. If leaking does not stop, shut down engine (TM 5-2420-222-10) and replace leaking connection packing or hoses outlined in this task. d. If found leaking, repeat steps 32 thru 34. 	
35.	Engine	If still running, shut down (TM 5-2420-222-20).	

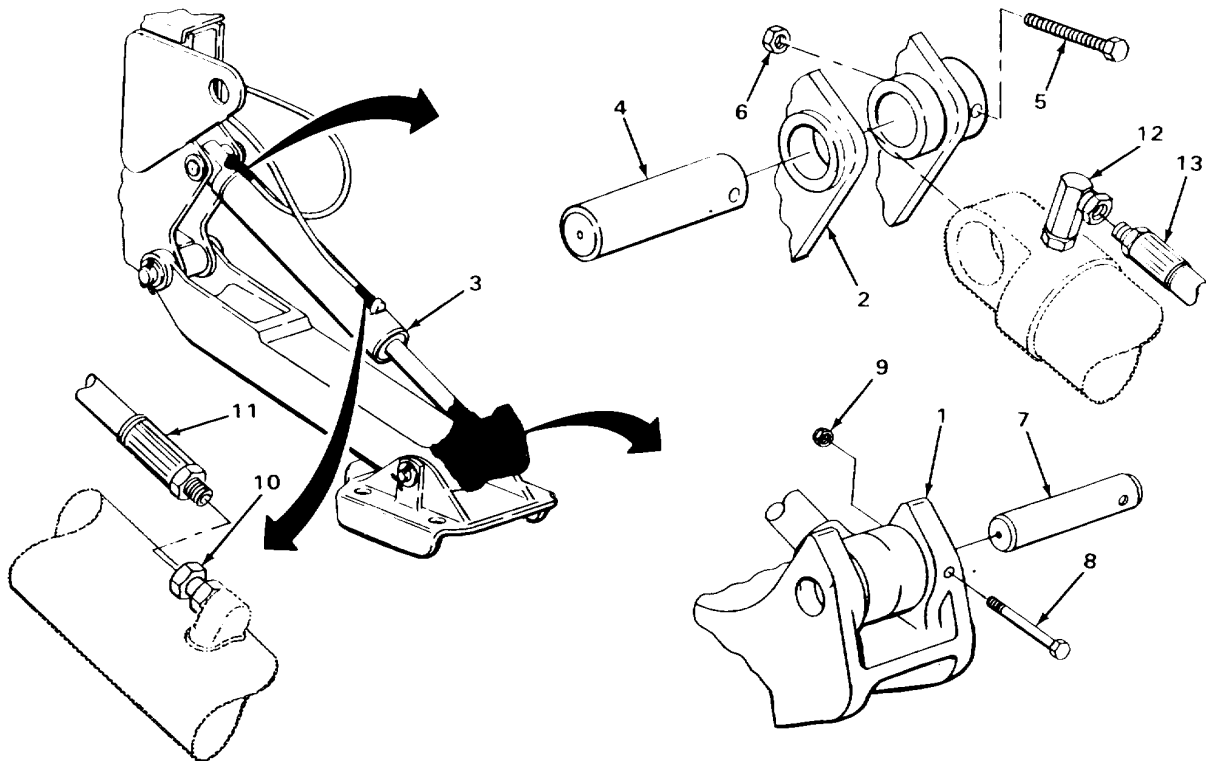

TA243574

TASK ENDS HERE

LOADER BUCKET CYLINDERS

This task covers:

-
- | | |
|------------------------------|---|
| a. Removal (page 2-1760) | d. Inspection/Replacement (page 2-1765) |
| b. Disassembly (page 2-1763) | e. Assembly (page 2-1765) |
| c. Cleaning (page 2-1764) | f. Installation (page 2-1766) |
-

INITIAL SETUP

Tools

- Driftpin, brass-tipped, 3/4-inch
- Hammer, cross-peen, 3-pound head
- Knife, pocket
- Lifting equipment, 200-pound capacity
- Pan, drain
- Pliers, retaining ring
- Pliers, snapping
- Screwdriver, flat-tip, 1/4-inch
- Wrench, open-end, 7/16-inch
- Wrench, open-end, 7/8-inch
- Wrench, open-end, 1-inch

Materials/Parts

- Packing, adapter-to-cylinder (two required)
- Rags, wiping (item 21, Appendix C)
- Solvent, drycleaning (item 28, Appendix C)
- Tags, marking (item 30, Appendix C)

Personnel Required

One

Equipment Condition

Hydraulic system pressure released (page 2-1191)

NOTE

The following tools only apply to right-hand loader bucket cylinders.

- Handle, ratchet, 3/8-inch drive
- Socket, 3/8-inch drive, 9/16-inch

LOCATION	ITEM	ACTION	REMARKS
----------	------	--------	---------

NOTE

Both loader bucket cylinders are maintained the same way except as noted. Right side is shown. Repeat procedures for left side as needed.

REMOVAL

- | | | |
|---|----------------|---|
| 1. Loader bucket cylinder (1) and two lines (2 and 3) | Two clamps (4) | <ul style="list-style-type: none"> a. Note positions for proper placement during installation. b. Using 1/4-inch flat-tip screwdriver, loosen and take off. |
|---|----------------|---|

LOADER BUCKET CYLINDERS - CONTINUED

LOCATION	ITEM	ACTION	REMARKS
----------	------	--------	---------

WARNING

Do not attempt to disconnect hydraulic lines and fittings while engine is running or before hydraulic system pressure has been released. When engine is running, hydraulic system is under pressure. Hydraulic system pressure should be 0 psi (0 kPa) before lines are disconnected. A line or fitting disconnected under pressure will blow off with a lot of force and could cause serious injury to personnel.

Be careful when draining hot fluids. Wear gloves to protect your hands from hot parts and fluids or severe burns could result.

- | | | |
|----------------|----------|---|
| 2. Adapter (5) | Line (2) | <ul style="list-style-type: none"> a. Place drain pan underneath. b. Using 7/8-inch and 1-inch open-end wrenches, unscrew and take off. c. Cap (page 2-137). d. Tag (page 2-137). |
| 3. Adapter (6) | Line (3) | <ul style="list-style-type: none"> a. Place drain pan underneath. b. Using 7/8-inch and 1-inch open-end wrenches, unscrew and take off. c. Cap (page 2-137). d. Tag (page 2-137). |

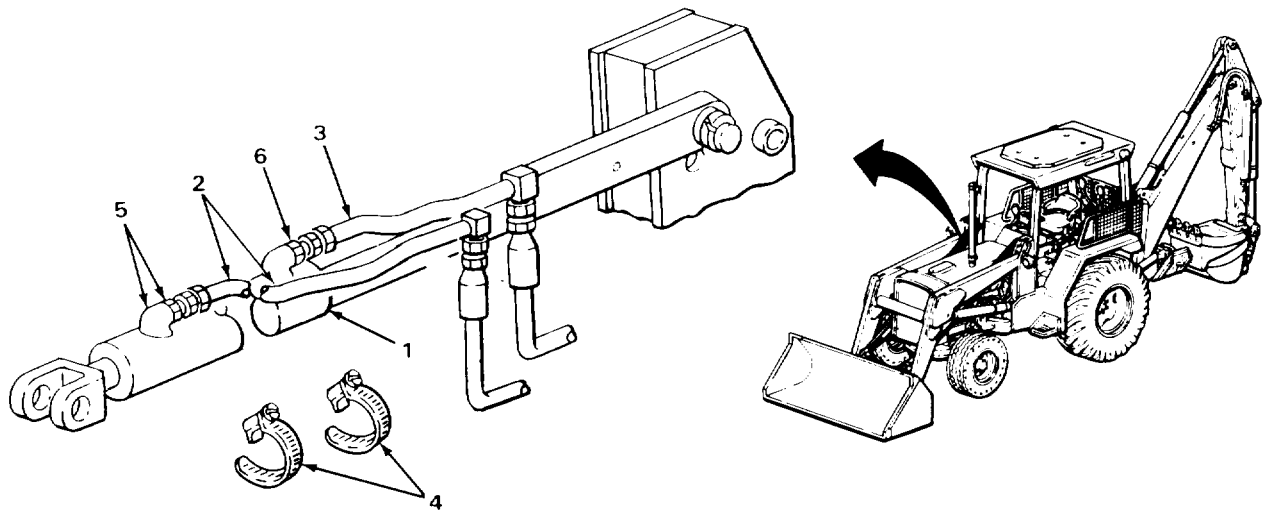

LOADER BUCKET CYLINDERS - CONTINUED

LOCATION	ITEM	ACTION	REMARKS
----------	------	--------	---------

REMOVAL - CONTINUED

WARNING

Some parts are heavy. Be careful when handling them. Lifting equipment is needed when parts weigh over 50 pounds (23 kg) for a single person lift, over 100 pounds (45 kg) for a two person lift, and over 150 pounds (68 kg) for a three or more person lift. Do not try to handle heavy parts without lifting equipment. Keep clear of heavy parts supported only by lifting equipment. Failure to observe this precaution could cause serious injury or death of personnel.

- | | | |
|--|----------------------------|--|
| 4. Loader side frame (1) and two front guide links (2 and 3) | Loader bucket cylinder (4) | Using 200-pound capacity lifting equipment, support. |
| 5. Two front guide links (2 and 3) and pin (5) | Two rings (6) | Using snapping pliers, take off. |

NOTE

Right side loader bucket cylinder has indicator pivot, left side bucket cylinder has washer.

- | | | |
|--|---|--|
| 6. Two front guide links (2 and 3), indicator pivot (7) or washer (8), loader bucket cylinder (4), and bucket link (9) | Pin (5) | Using 3-pound head cross-peen hammer and 3/4-inch brass-tipped drift pin, drive out. |
| 7. Loader bucket cylinder (4) | Two front guide links (2 and 3), indicator pivot (7) or washer (8), and bucket link (9) | Take off. |
| 8. Loader side frame (1) and loader bucket cylinder (4) | Ring (10) and washer (11) | Using retaining ring pliers, take off. |

LOADER BUCKET CYLINDERS - CONTINUED

LOCATION	ITEM	ACTION	REMARKS
9. Loader side frame (1)	Loader bucket cylinder (4)	a. Using 200-pound capacity lifting equipment, take off. b. Take off 200-pound capacity lifting equipment.	
DISASSEMBLY			
10. Loader bucket cylinder (4)	Adapter (12) with assembled packing (13)	a. Using 1-inch open-end wrench, unscrew and take out. b. Plug cylinder (4) (page 2-137).	
11. Adapter (12)	Packing (13)	a. Using pocket knife, take off. b. Get rid of.	
12. Loader bucket cylinder (4)	Adapter (14) with assembled packing (15)	a. Using 1-inch open-end wrench, unscrew and take out. b. Plug cylinder (4) (page 2-137).	

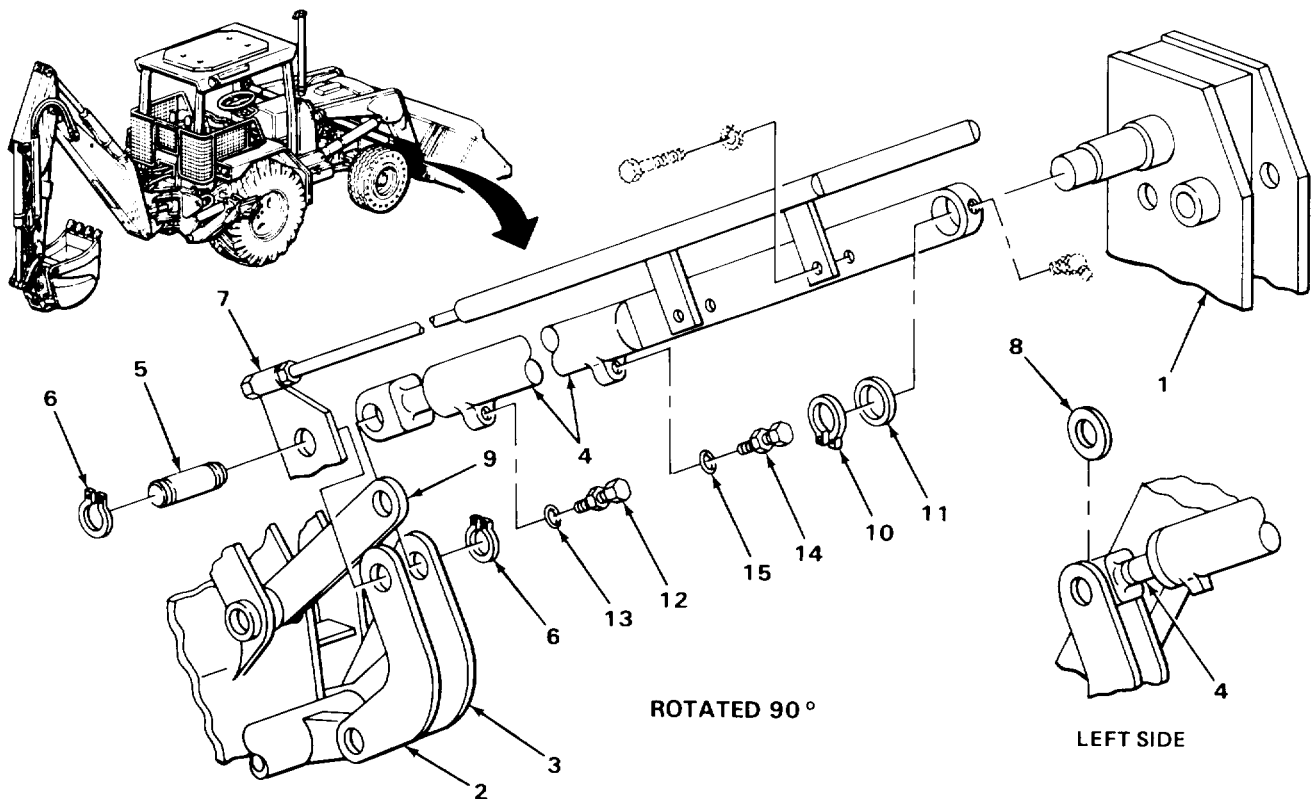

TA243576

LOADER BUCKET CYLINDERS - CONTINUED

LOCATION	ITEM	ACTION	REMARKS
DISASSEMBLY - CONTINUED			
13.	Adapter (1)	Packing (2)	a. Using pocket knife, take off. b. Get rid of.
14.	Loader bucket cylinder (3)	Grease fitting (4)	Using 7/16-inch open-end wrench, unscrew and take out.
NOTE			
If disassembling left loader bucket cylinder, skip steps 15 and 16.			
15.	Loader bucket cylinder (3) and indicator guide tube (5)	Two screws (6) and lockwashers (7)	a. Using 9/16-inch, 3/8-inch drive socket and ratchet handle, unscrew and take out. b. Get rid of lockwashers (7).
16.	Loader bucket cylinder (3)	Indicator guide tube (5) with assembled parts	Take off.
CLEANING			
NOTE			
For more information on how to clean parts, go to General Maintenance Instructions (page 2-137).			
WARNING			
Drycleaning solvent P-D-680 is toxic and flammable. Wear protective goggles and gloves and use only in a well ventilated area. Avoid contact with skin, eyes, and clothes and don't breathe vapors. Do not use near open flame or excessive heat. The flashpoint is 100°F to 138°F (38° to 59°C). If you become dizzy while using cleaning solvent, get fresh air immediately and get medical aid. If contact with eyes is made, wash your eyes with water and get medical aid immediately.			
17.	Loader bucket cylinder (3)		a. Using clean rags dampened in drycleaning solvent, wipe clean. b. Using clean, dry rags, wipe dry.
18.	All other metal parts		a. Clean in drycleaning solvent. b. Using clean, dry rags, wipe dry.

LOADER BUCKET CYLINDERS - CONTINUED

LOCATION	ITEM	ACTION	REMARKS
----------	------	--------	---------

INSPECTION/REPLACEMENT

NOTE

For more information on how to inspect parts, go to General Maintenance Instructions (page 2-137).

Replace defective parts as needed.

- | | | | |
|-----|----------------------------|-----------------------------|--|
| 19. | Loader bucket cylinder (3) | Look for cracks and breaks. | |
| 20. | All threaded parts | Look for damaged threads. | |

ASSEMBLY

NOTE

If assembling left loader bucket cylinder, skip steps 21 and 22.

- | | | | |
|--------------------------------|---|--------------------|--|
| 21. Loader bucket cylinder (3) | Indicator guide tube (5) with assembled parts | Place in position. | |
|--------------------------------|---|--------------------|--|

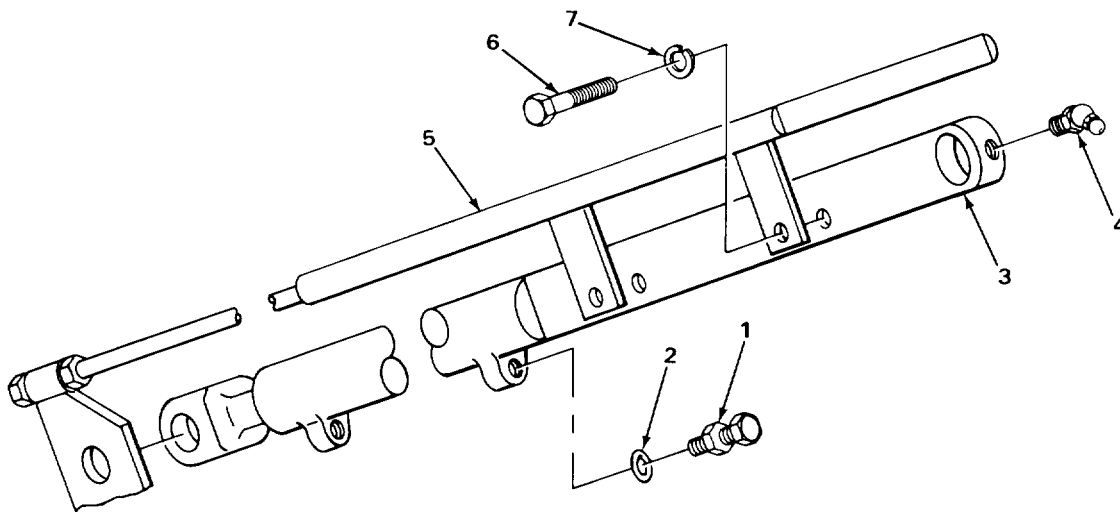

TA243577

LOADER BUCKET CYLINDERS - CONTINUED

LOCATION	ITEM	ACTION	REMARKS
ASSEMBLY - CONTINUED			
22.	Loader bucket cylinder (1) and indicator guide tube (2)	Two screws (3) and new lockwashers (4)	Screw in and tighten using 9/16-inch, 3/8-inch drive socket and ratchet handle.
23.	Loader bucket cylinder (1)	Grease fitting (5)	Screw in and tighten using 7/16-inch open-end wrench.
24.	Adapter (6)	New packing (7)	Place in position.
25.	Loader bucket cylinder (1)	Adapter (6) with assembled packing (7)	a. Unplug cylinder (1). b. Screw in and tighten using 1-inch open-end wrench.
26.	Adapter (8)	New packing (9)	Place in position.
27.	Loader bucket cylinder (1)	Adapter (8) with assembled packing (9)	a. Unplug cylinder (1). b. Screw in and tighten using 1-inch open-end wrench.

INSTALLATION

WARNING

Some parts are heavy. Be careful when handling them. Lifting equipment is needed when parts weigh over 50 pounds (23 kg) for a single person lift, over 100 pounds (45 kg) for a two person lift, and over 150 pounds (68 kg) for a three or more person lift. Do not try to handle heavy parts without lifting equipment. Keep clear of heavy parts supported only by lifting equipment. Failure to observe this precaution could cause serious injury or death of personnel.

28.	Loader side frame (10)	Loader bucket cylinder (1)	Using 200-pound capacity lifting equipment, place into position and support.
29.	Loader side frame (10) and loader bucket cylinder (1)	Ring (11) and washer (12)	Using retaining ring pliers, put on.

NOTE

Right side of loader bucket cylinder has indicator pivot, left side bucket cylinder has washer.

LOADER BUCKET CYLINDERS - CONTINUED

LOCATION	ITEM	ACTION	REMARKS
30. Loader bucket cylinder (1)	Two front guide links (13 and 14), indicator pivot (15) or washer (16), and bucket link (17)	Place into position.	
31. Two front guide links (13 and 14), indicator pivot (15) or washer (16), loader bucket cylinder (1), and bucket link (17)	Pin (18)	Using 3-pound head cross-peen hammer, drive in.	
32. Two front guide links (13 and 14) and pin (18)	Two rings (19)	Using snapping pliers, put on.	

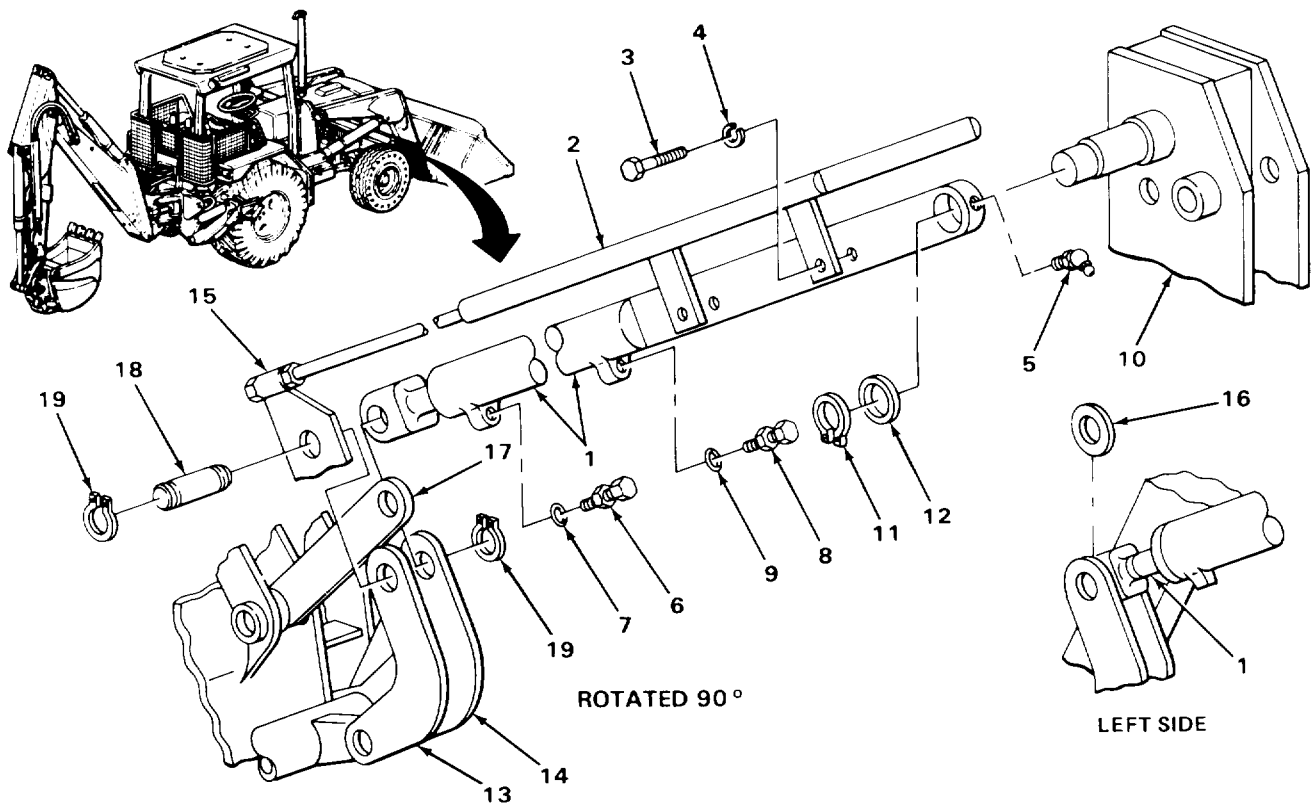

TA243578

LOADER BUCKET CYLINDERS - CONTINUED

LOCATION	ITEM	ACTION	REMARKS
INSTALLATION- CONTINUED			
WARNING			
Some parts are heavy. Be careful when handling them. Lifting equipment is needed when parts weigh over 50 pounds (23 kg) for a single person lift, over 100 pounds (45 kg) for a two person lift, and over 150 pounds (68 kg) for a three or more person lift. Do not try to handle heavy parts without lifting equipment. Keep clear of heavy parts supported only by lifting equipment. Failure to observe this precaution could cause serious injury or death of personnel.			
33. Loader side frame (1)	Loader bucket cylinder (2)	Take off 200-pound capacity lifting equipment.	
34. Adapter (3)	Line (4)	<ul style="list-style-type: none"> a. Take off tag. b. Uncap. c. Screw in and tighten using 7/8-inch and 1-inch open-end wrenches. 	
35. Adapter (5)	Line (6)	<ul style="list-style-type: none"> a. Take off tag. b. Uncap. c. Screw in and tighten using 7/8-inch and 1-inch open-end wrenches. 	
36. Loader bucket cylinder (2) and two lines (4 and 6)	Two clamps (7)	<ul style="list-style-type: none"> a. Place into position as noted during removal. b. Screw in and tighten using 1/4-inch flat-tip screwdriver. 	
37. Loader backhoe	Transmission	Check fluid level and add proper amount and grade (TM 5-2420-222-10).	
38.	Engine	Start and run at high idle (TM 5-2420-222-10).	
39.	Loader bucket cylinder (1), two adapters (3 and 5), and lines (4 and 6) wrenches.	<ul style="list-style-type: none"> a. Operate loader bucket (TM 5-2420-222-10) and check for leaks. b. If leaking at any connection, tighten using 7/8-inch and 1-inch open-end wrenches. c. If leaking does not stop, shut down engine (TM 5-2420-222-10) and replace leaking connection packing as outlined in this task. d. If found leaking, repeat steps 37 thru 39. 	

LOADER BUCKET CYLINDERS - CONTINUED

LOCATION	ITEM	ACTION	REMARKS
----------	------	--------	---------

40. Loader backhoe

Engine

If still running, shut down (TM 5-2420-222-10).

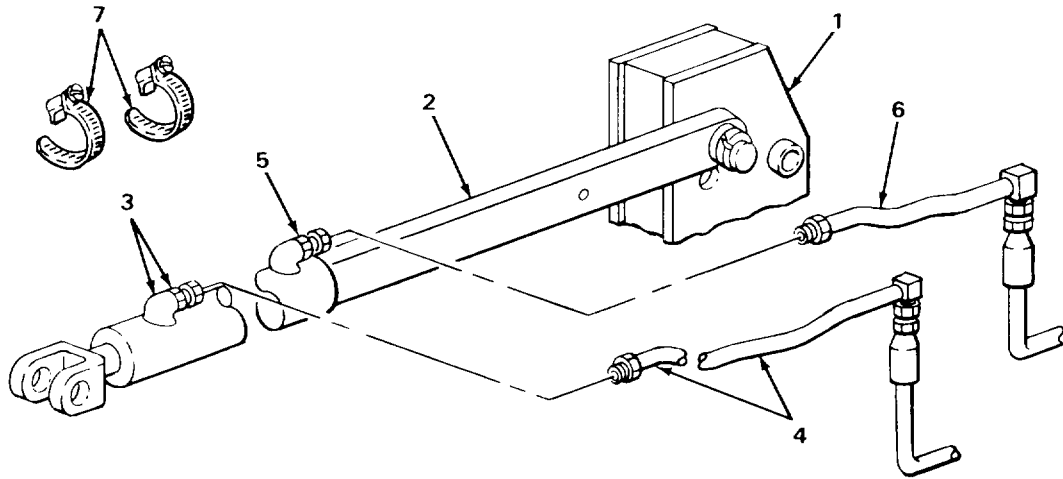

TASK ENDS HERE

LOADER BOOM CYLINDERS

This task covers:

- | | |
|------------------------------|---|
| a. Removal (page 2-1770) | d. Inspection/Replacement (page 2-1774) |
| b. Disassembly (page 2-1772) | e. Assembly (page 2-1774) |
| c. Cleaning (page 2-1774) | f. Installation (page 2-1776) |

INITIAL SETUP

Tools

Driftpin, brass-tipped, 3/4-inch
 Hammer, cross-peen, 3-pound head
 Knife, pocket
 Lifting equipment, 200-pound capacity
 Pan, drain
 Pliers, retaining ring
 Screwdriver, flat-tip, 1/4-inch
 Wrench, open-end, 7/16-inch
 Wrench, open-end, 7/8-inch
 Wrench, open-end, 1-inch
 (two required)

Materials/Parts

Packing, adapter-to-cylinder
 Packing, union-to-cylinder

Materials/Parts - Continued

Rags, wiping (item 21, Appendix C)
 Solvent, drycleaning (item 28, Appendix C)
 Tags, marking (item 30, Appendix C)

Personnel Required

One

Equipment Condition

Hydraulic system pressure released
 (page 2-1191)

LOCATION	ITEM	ACTION	REMARKS
----------	------	--------	---------

NOTE

**Both loader boom cylinders are maintained the same way. Right side is shown.
 Repeat procedures for left side as needed.**

REMOVAL

- | | | |
|--|-----------|--|
| 1. Loader boom cylinder (1) and hose (2) | Clamp (3) | a. Note position for proper placement during assembly.
b. Using 1/4-inch flat-tip screwdriver, loosen and take off. |
|--|-----------|--|

LOADER BOOM CYLINDERS - CONTINUED

LOCATION	ITEM	ACTION	REMARKS
----------	------	--------	---------

WARNING

Do not attempt to disconnect hydraulic lines and fittings while engine is running or before hydraulic system pressure has been released. When engine is running, hydraulic system is under pressure. Hydraulic system pressure should be 0 psi (0 kPa) before lines are disconnected. A line or fitting disconnected under pressure will blow off with a lot of force and could cause serious injury to personnel.

Be careful when draining hot fluids. Wear gloves to protect your hands from hot parts and fluids or severe burns could result.

- | | | |
|----------------|----------|---|
| 2. Adapter (4) | Hose (2) | <ul style="list-style-type: none"> a. Place drain pan underneath. b. Using 7/8-inch and 1-inch open-end wrenches, unscrew and take out. c. Cap (page 2-137). d. Tag (page 2-137). |
|----------------|----------|---|

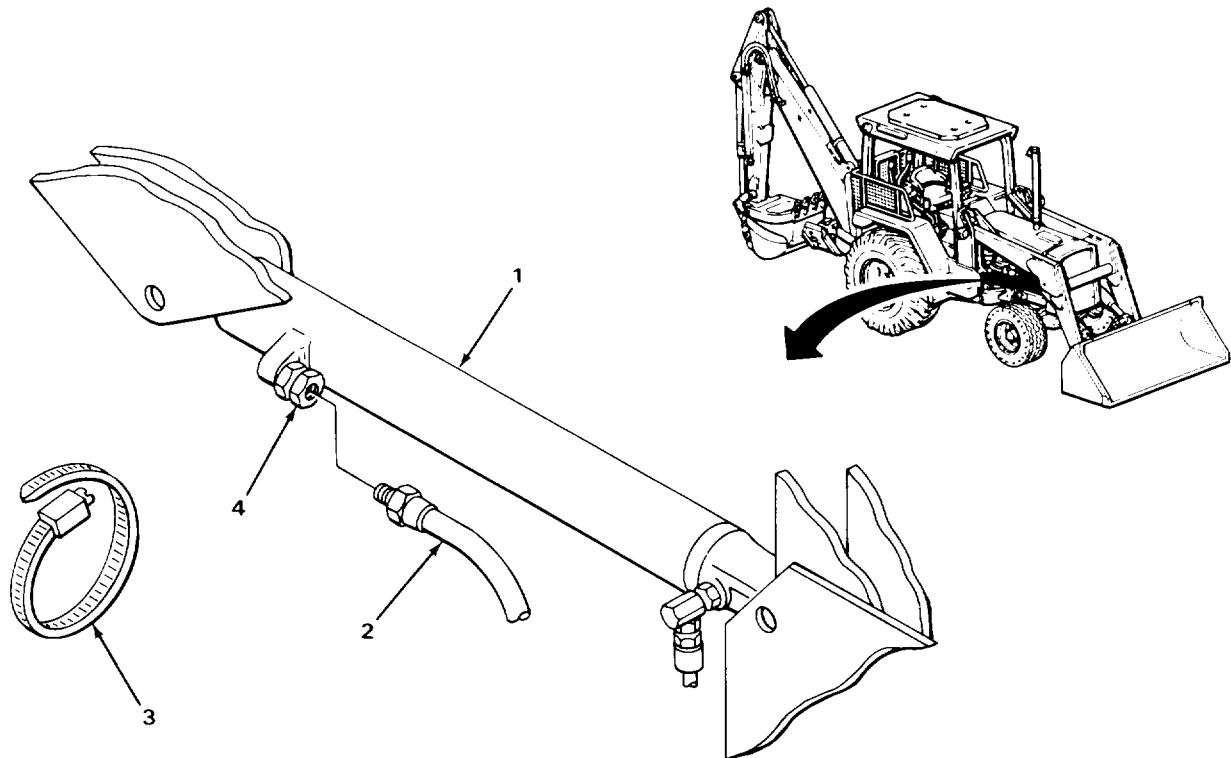

LOADER BOOM CYLINDERS - CONTINUED

LOCATION	ITEM	ACTION REMARKS
REMOVAL - CONTINUED		
3. Union (1)	Hose (2)	a. Place drain pan underneath. b. Using 7/8-inch and 1-inch open-end wrenches, unscrew and take out. c. Cap (page 2-137). d. Tag (page 2-137).
WARNING		
<p>Some parts are heavy. Be careful when handling them. Lifting equipment is needed when parts weigh over 50 pounds (23 kg) for a single person lift, over 100 pounds (45 kg) for a two person lift, and over 150 pounds (68 kg) for a three or more person lift. Do not try to handle heavy parts without lifting equipment. Keep clear of heavy parts supported only by lifting equipment. Failure to observe this precaution could cause serious injury or death of personnel.</p>		
4. Lift arms (3) and side frame (4)	Loader boom cylinder (5)	Using 200-pound capacity lifting equipment, support.
5. Lift arms (3) and pin (6)	Two rings (7)	Using retaining ring pliers, take off.
6. Lift arms (3) and loader boom cylinder (5)	Pin (6)	Using 3-pound head cross-peen hammer and 3/4-inch brass-tipped driftpin, drive out.
7. Side frame (4) and pin (8)	Two rings (9)	Using retaining ring pliers, take off.
8. Side frame (4) and loader boom cylinder (5)	Pin (8)	Using 3-pound head cross-peen hammer and 3/4-inch brass-tipped driftpin, drive out.
9. Lift arms (3) and side frame (4)	Loader boom cylinder (5)	a. Using 200-pound capacity lifting equipment, take off. b. Take off 200-pound capacity lifting equipment.
DISASSEMBLY		
10. Loader boom cylinder (5)	Adapter (10) with assembled packing (11)	a. Using 1-inch open-end wrench, unscrew and take out. b. Plug cylinder (5) (page 2-137).

LOADER BOOM CYLINDERS - CONTINUED

LOCATION	ITEM	ACTION	REMARKS
11. Adapter(10)	Packing (11)	a. Using pocket knife, take out. b. Get rid of.	
12. Loader boom cylinder (5) and union (1)	Nut (12)	Using two 1-inch open-end wrenches, loosen.	
13. Loader boom cylinder (5)	Union (1) with assembled parts	a. Note relative position for proper placement during installation. b. Using 1-inch open-end wrench, unscrew and take out. c. Plug cylinder (5) (page 2-137).	
14. Union (1)	Packing (13)	a. Using pocket knife, take out. b. Get rid of.	

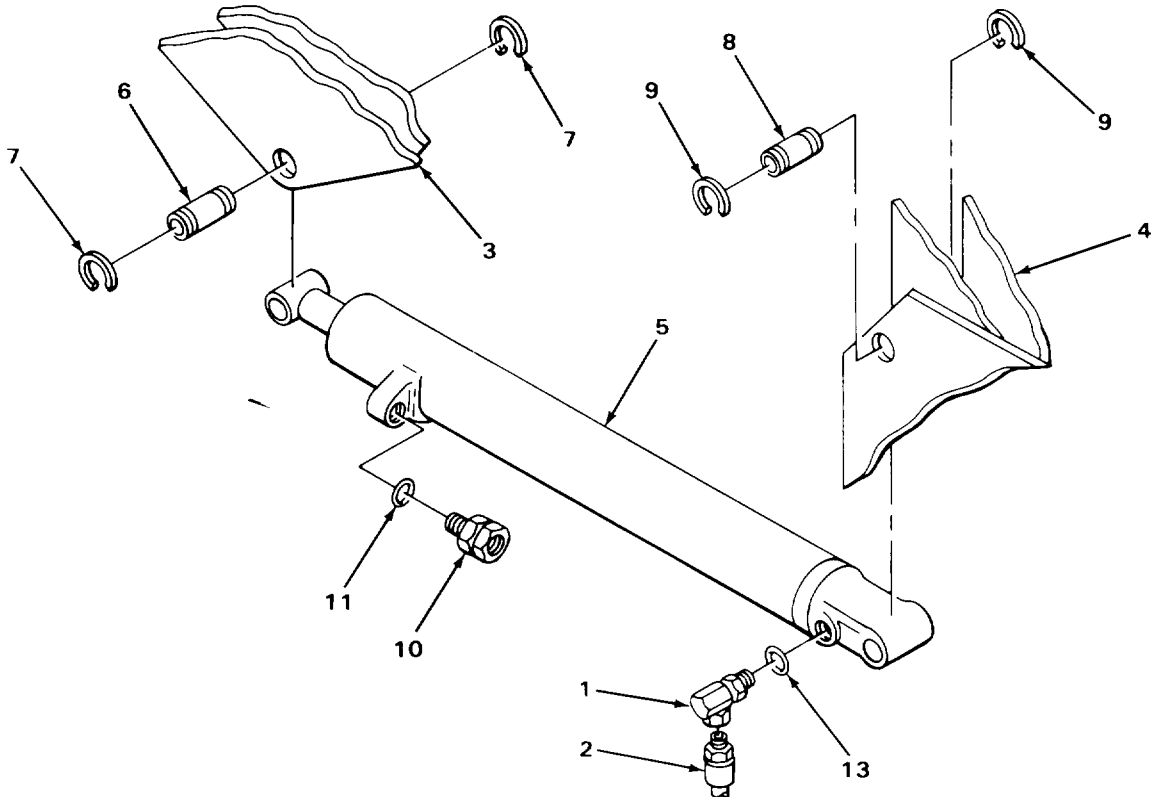

TA243581

LOADER BOOM CYLINDERS - CONTINUED

LOCATION	ITEM	ACTION	REMARKS
DISASSEMBLY - CONTINUED			
15.	Loader boom cylinder (1)	Two grease fittings (2 and 3)	Using 7/16-inch open-end wrench, unscrew and take out.
CLEANING			
NOTE			
For more information on how to clean parts, go to General Maintenance Instructions (page 2-137) .			
<u>WARNING</u>			
Drycleaning solvent P-D-680 is toxic and flammable. Wear protective goggles and gloves and use only in a well ventilated area. Avoid contact with skin, eyes, and clothes and don't breathe vapors. Do not use near open flame or excessive heat. The flashpoint is 100°F to 138°F (38° to 59°C). If you become dizzy while using cleaning solvent, get fresh air immediately and get medical aid. If contact with eyes is made, wash your eyes with water and get medical aid immediately.			
16.	Loader boom cylinder (1)		a. Using clean rags dampened in dry-cleaning solvent, wipe clean. b. Using clean, dry rags, wipe dry.
17.	All other metal parts		a. Clean in drycleaning solvent. b. Using clean, dry rags, wipe dry.
INSPECTION/REPLACEMENT			
NOTE			
For more information on how to inspect parts, go to General Maintenance Instructions (page 2-137) .			
Replace defective parts as needed.			
18.	Loader boom cylinder (1)		Look for cracks or breaks.
19.	All threaded parts		Look for damaged threads.
ASSEMBLY			
20.	Loader boom cylinder (1)	Two grease fittings (2 and 3)	Screw in and tighten using 1/4-inch open-end wrench.

LOADER BOOM CYLINDERS - CONTINUED

LOCATION	ITEM	ACTION REMARKS
21. Union (4)	Nut (5)	Screw in all the way.
22.	New packing (6)	Place in position.
23. Loader boom cylinder (1)	Union (4) with assembled packing (6)	a. Unplug cylinder (1). b. Screw into same relative position as noted during removal using 1-inch open-end wrench.
24. Loader boom cylinder (1) and union (4)	Nut (5)	Using two 1-inch open-end wrenches, tighten until seated against cylinder (1).

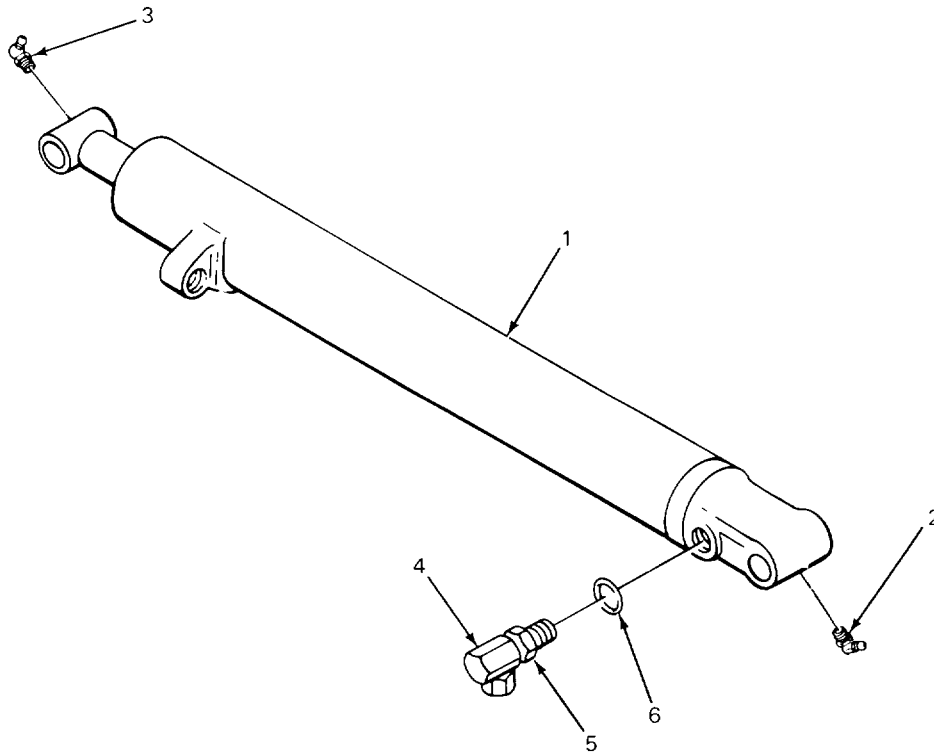

TA243582

LOADER BOOM CYLINDERS - CONTINUED

LOCATION	ITEM	ACTION	REMARKS
ASSEMBLY - CONTINUED			
25.	Adapter (1)	New packing (2)	Place in position.
26.	Loader boom cylinder (3)	Adapter (1) with assembled packing (2)	a. Unplug cylinder(3). b. Screw in and tighten using 1-inch open-end wrench.
INSTALLATION			
WARNING			
Some parts are heavy. Be careful when handling them. Lifting equipment is needed when parts weigh over 50 pounds (23 kg) for a single person lift, over 100 pounds (45 kg) for a two person lift, and over 150 pounds (68 kg) for a three or more person lift. Do not try to handle heavy parts without lifting equipment. Keep clear of heavy parts supported only by lifting equipment. Failure to observe this precaution could cause serious injury or death of personnel.			
27.	Lift arms (4) and side frame (5)	Loader boom cylinder (3)	Using 200-pound capacity lifting equipment, place into position and support alining pin holes.
28.	Side frame (5) and loader boom cylinder (3)	Pin (6) tap in.	Using 3-pound head cross-peen hammer,
29.	Side frame (5) and pin (6)	Two rings (7)	Using retaining ring pliers, put on.
30.	Lift arms (4) and loader boom cylinder (3)	Pin (8)	Using 3-pound head cross-peen hammer, tap in.
31.	Lift arms (4) and pin (8)	Two rings (9)	Using retaining ring pliers, put on.
32.	Lift arms (4)	Loader boom cylinder (3)	Take off 200-pound capacity lifting equipment.
33.	Union (10)	Hose (11)	a. Take off tag. b. Uncap. c. Using 7/8-inch and 1-inch open-end wrenches, screw in and tighten.

LOADER BOOM CYLINDERS - CONTINUED

LOCATION	ITEM	ACTION	REMARKS
34. Adapter (1)	Hose (12)	a. Takeoff tag. b. Uncap. c. Using 7/8-inch and 1-inch open-end wrenches, screw in and tighten.	
35. Loader boom cylinder (3)	Clamp (13)		Place into position as noted during removal and tighten using 1/4-inch flat-tip screwdriver.
36. Loader backhoe	Transmission		Check fluid level and add proper amount and grade (TM 5-2420-222-10).
37.	Engine		Start and run at high idle (TM 5-2420-222-10).

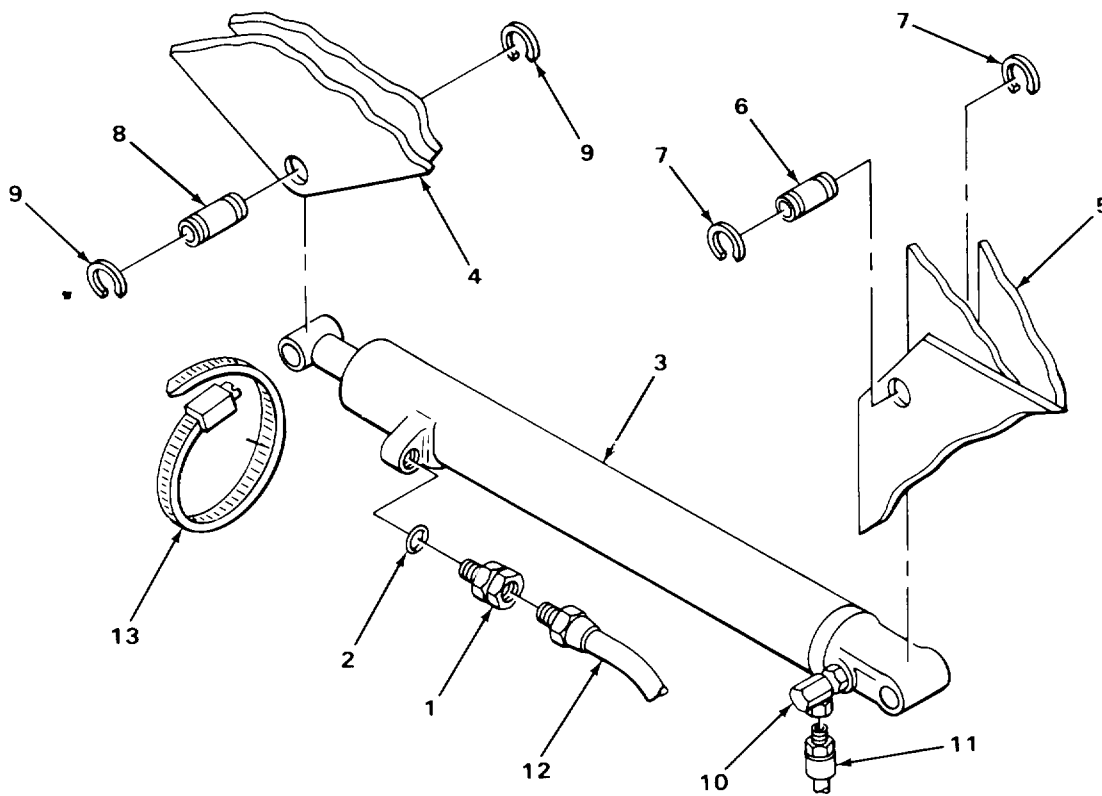

LOADER BOOM CYLINDERS - CONTINUED

LOCATION	ITEM	ACTION REMARKS
INSTALLATION - CONTINUED		
38.	Loader boom cylinder (1), union (2), hose (3), adapter (4), and hose (5)	<ul style="list-style-type: none"> a. Operate lift arms (TM 5-2420-222-10) and check for leaks. b. If leaking at any connection, tighten using 7/8-inch and two 1-inch open-end wrenches. c. If leaking does not stop, shut down engine (TM 5-2420-222-10) and replace leaking connection packing, hose, or fitting as outlined in this task. d. If found leaking, repeat steps 36 thru 38.
39.	Engine	If still running, shut down (TM 5-2420-222-20).

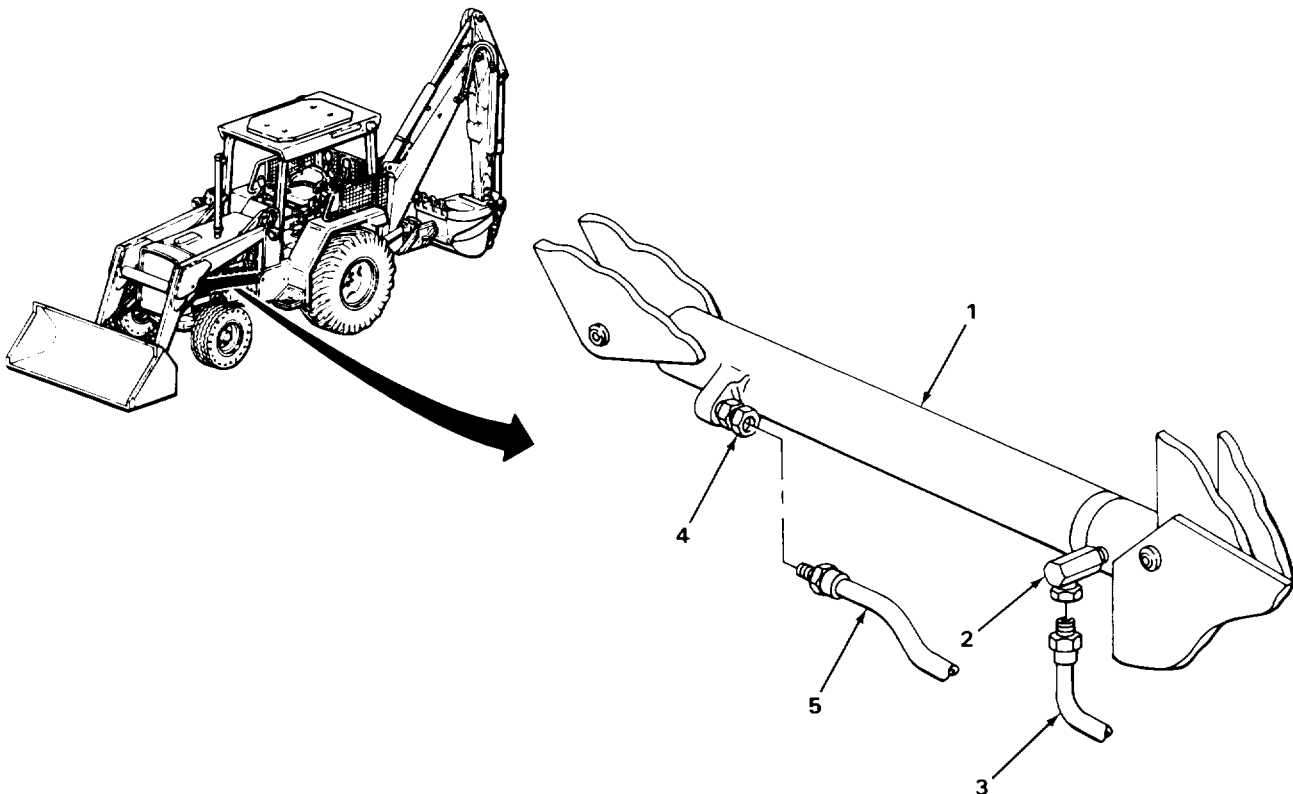

TASK ENDS HERE

TA243584

HYDRAULIC SYSTEM DIAGRAM (SERIAL NUMBERS 235786 THRU 235999 ONLY)

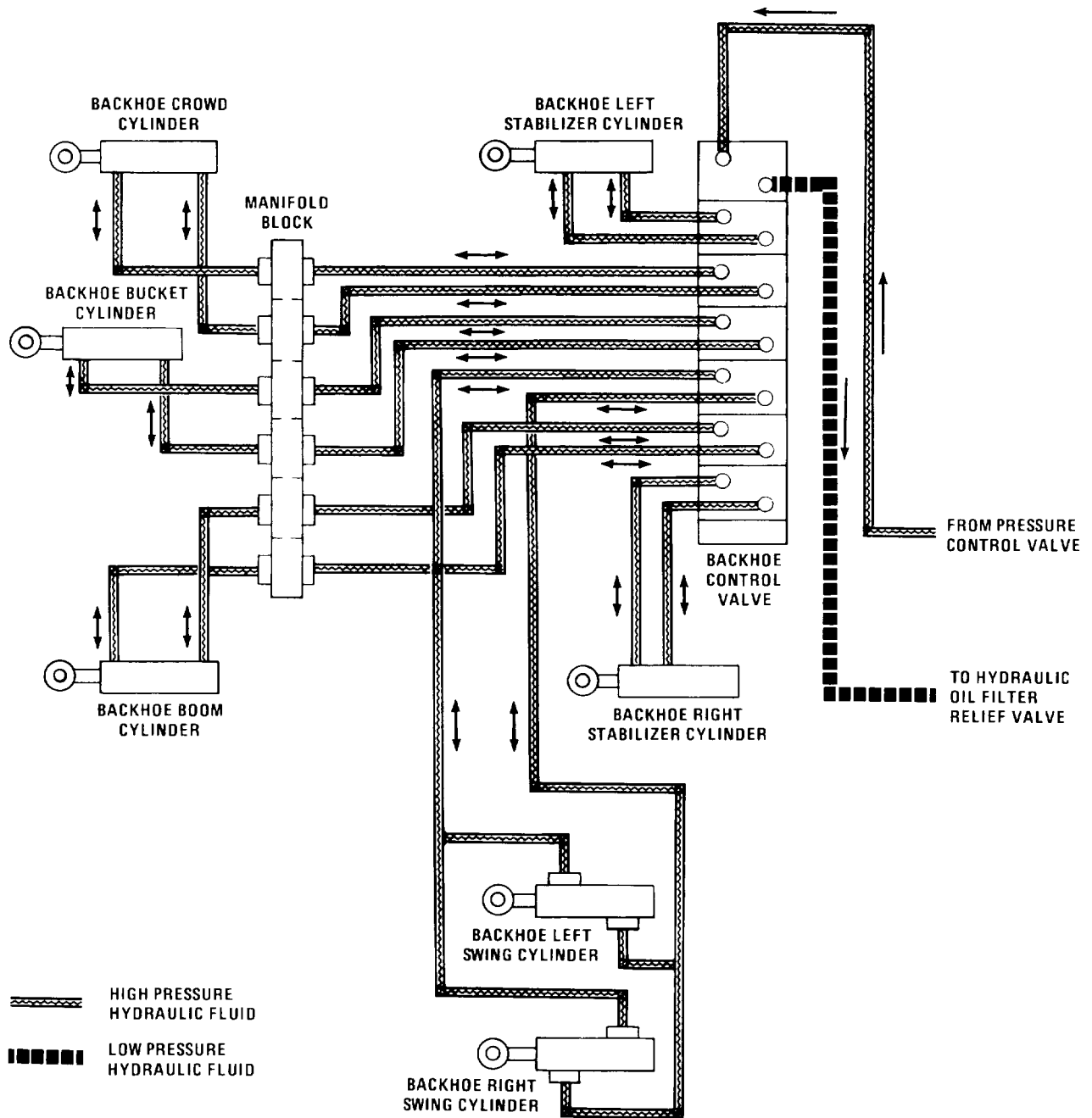

TA243585

HYDRAULIC SYSTEM DIAGRAM (SERIAL NUMBERS 235786 THRU 235999 ONLY) - CONTINUED

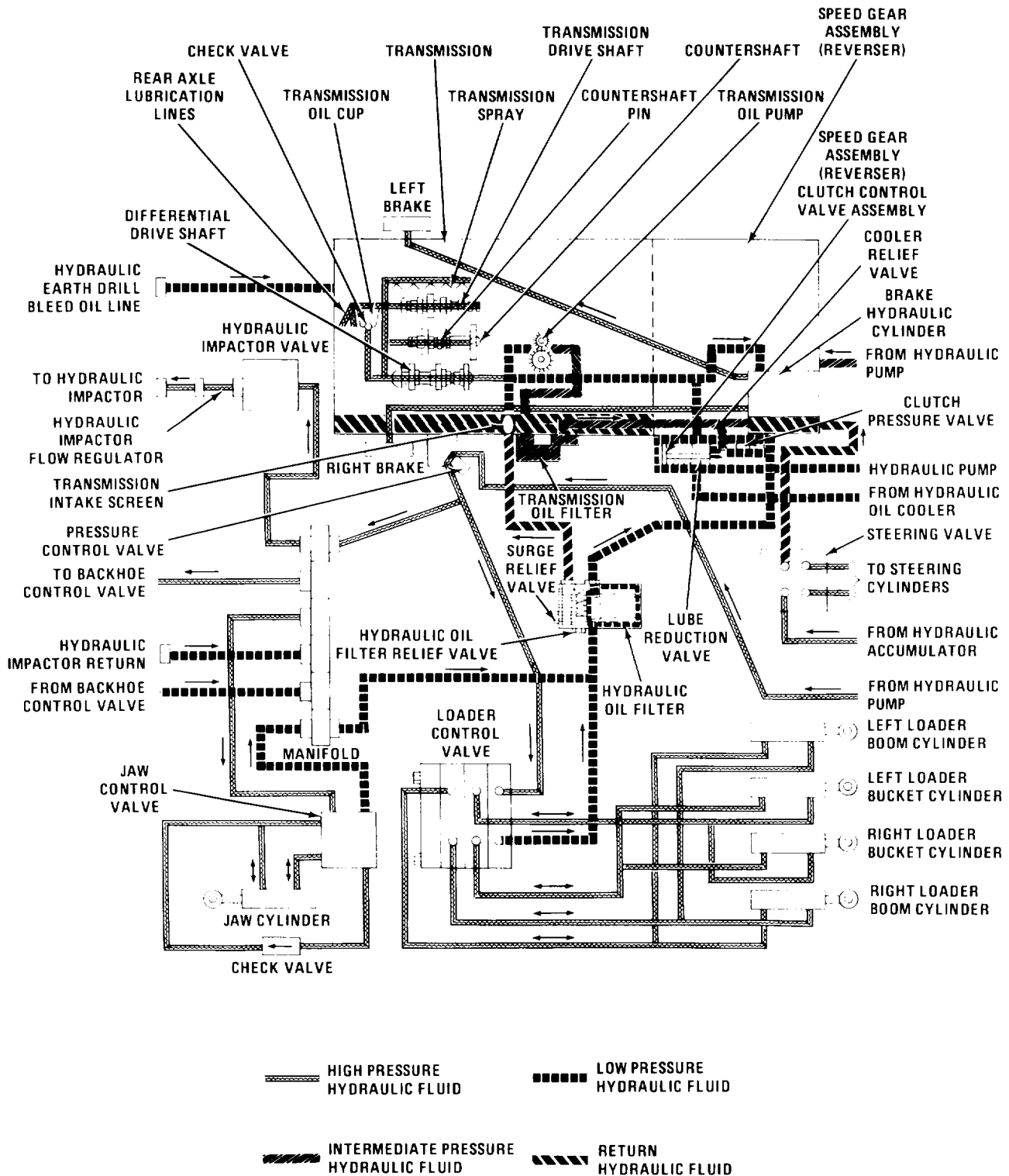

TA243586

HYDRAULIC SYSTEM DIAGRAM (SERIAL NUMBERS 235786 THRU 235999 ONLY) - CONTINUED

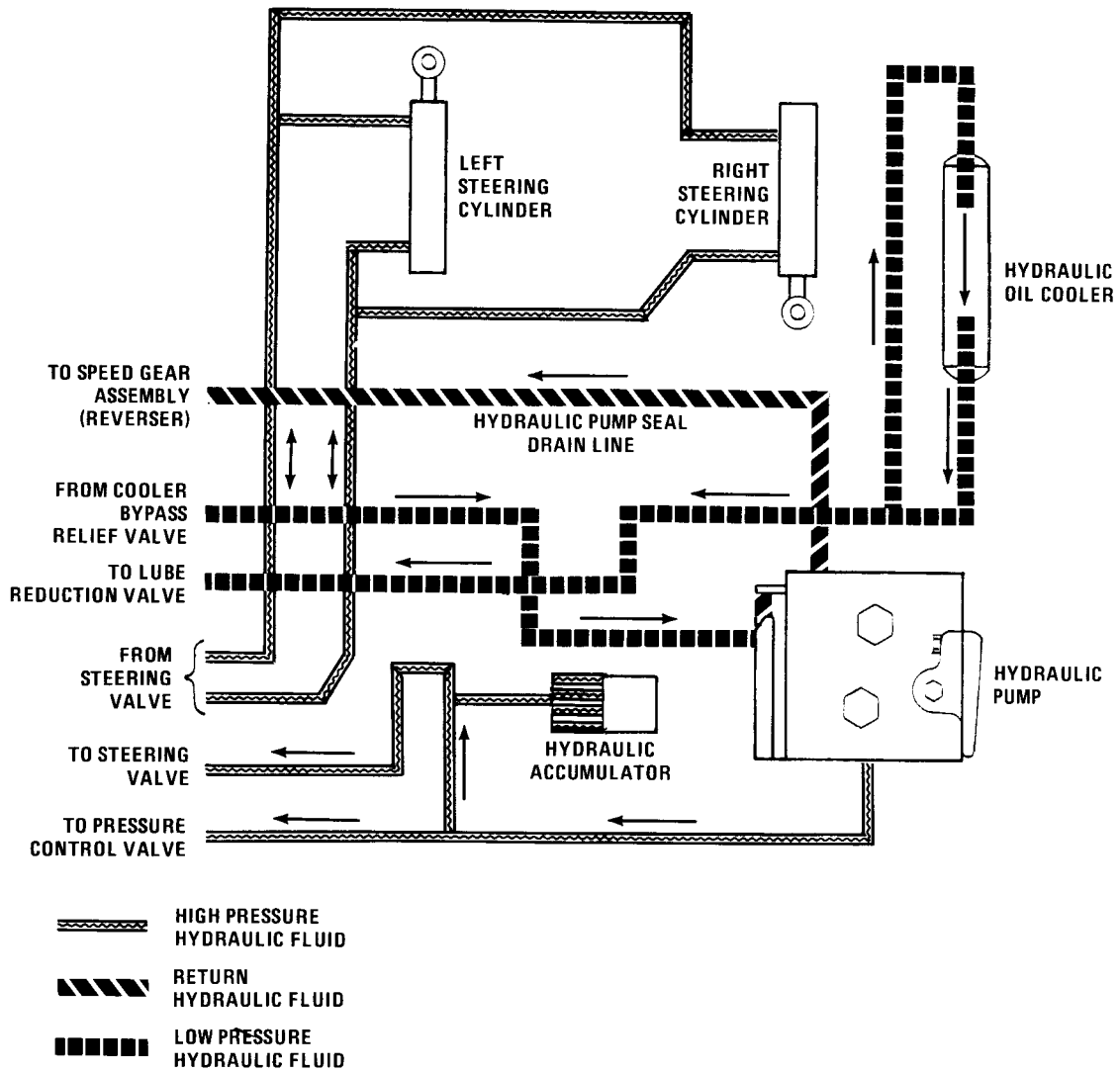

HYDRAULIC SYSTEM DIAGRAM (SERIAL NUMBERS 31995 THRU 342573 ONLY)

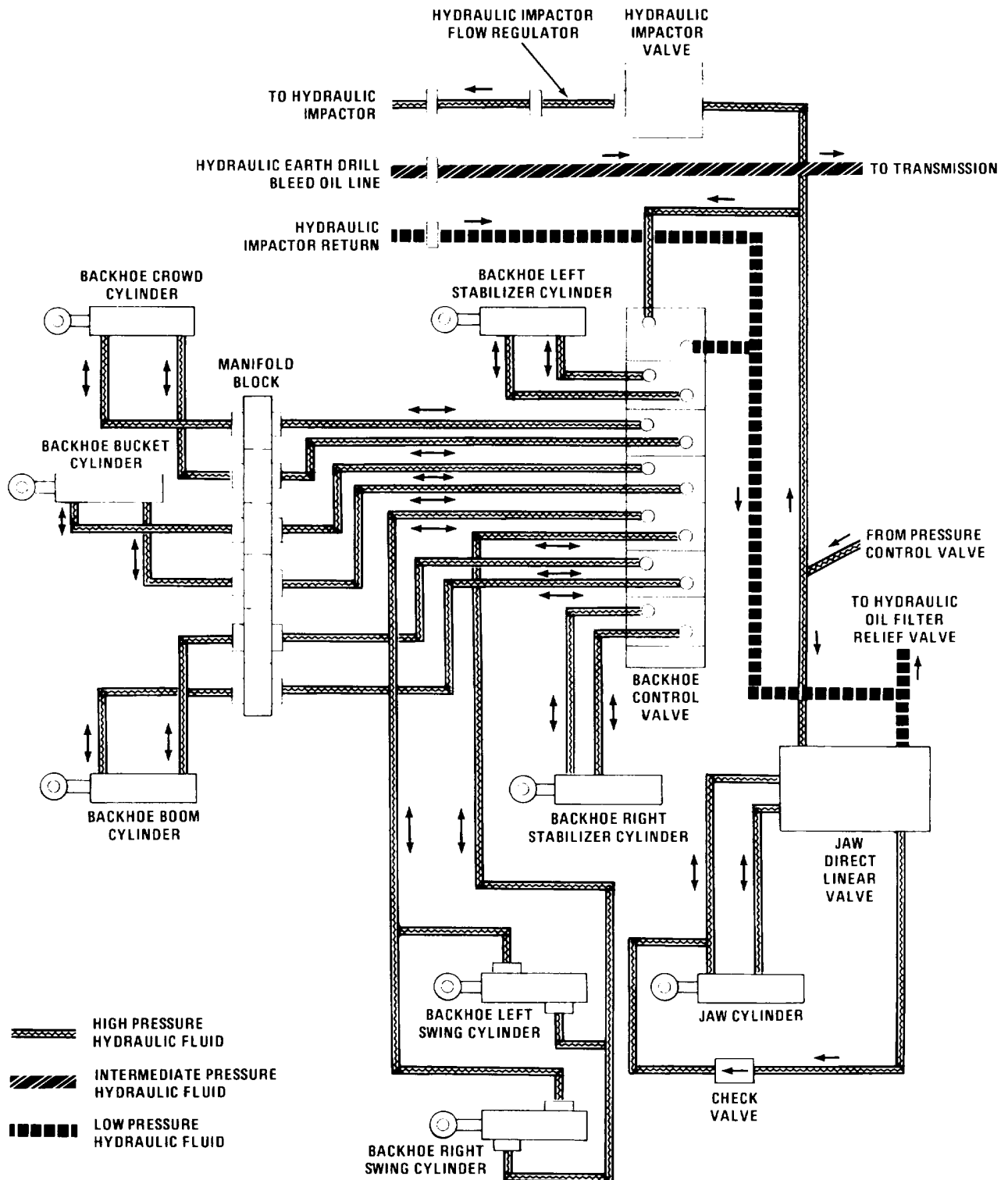

TA243588

HYDRAULIC SYSTEM DIAGRAM (SERIAL NUMBERS 319995 THRU 342573 ONLY) - CONTINUED

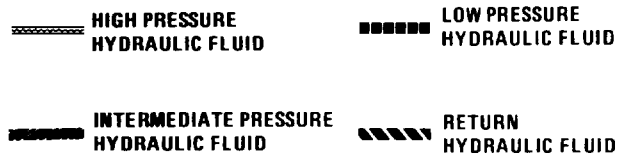
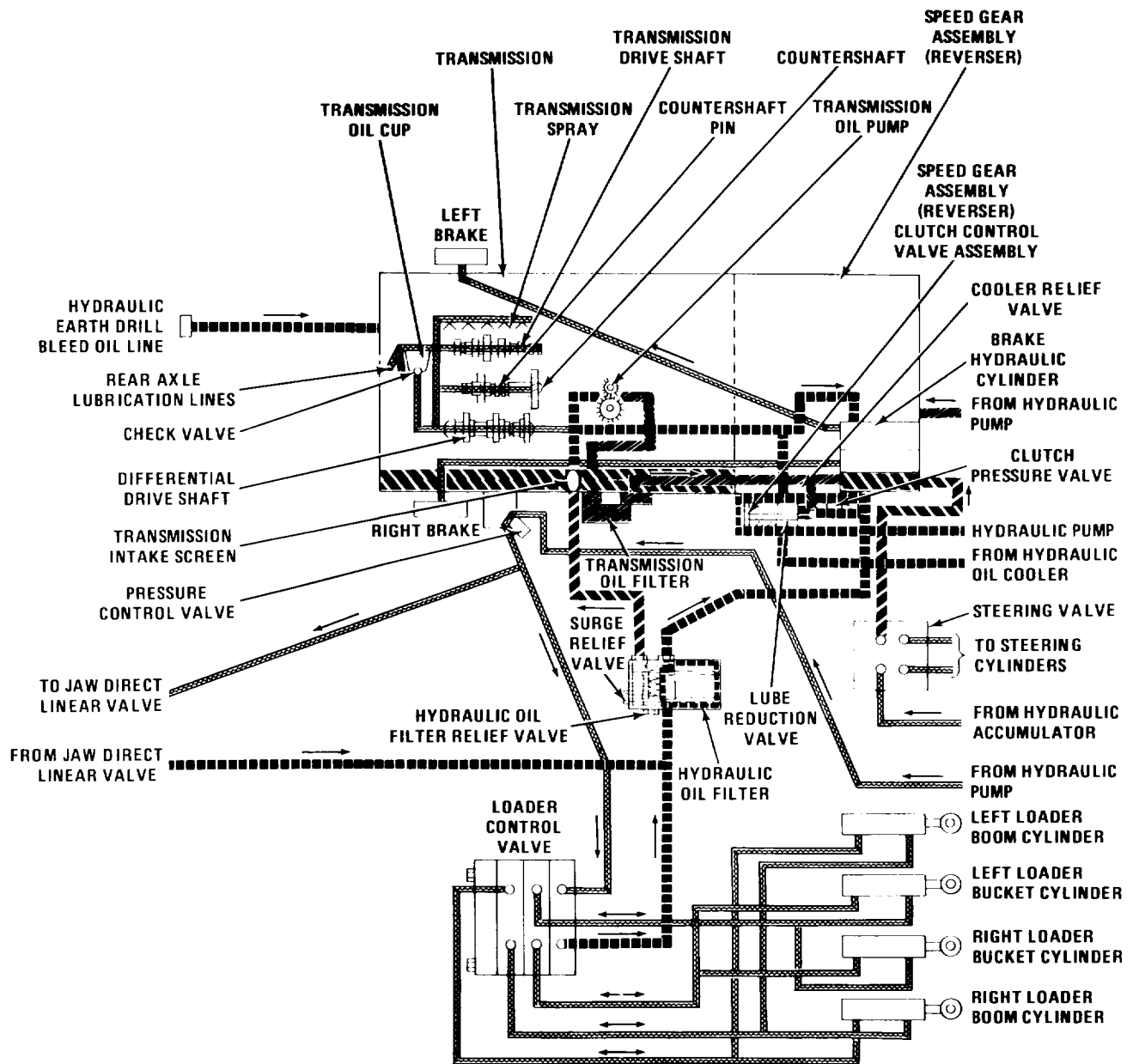

TA243589

HYDRAULIC SYSTEM DIAGRAM (SERIAL NUMBERS 31995 THRU 342573 ONLY) - CONTINUED

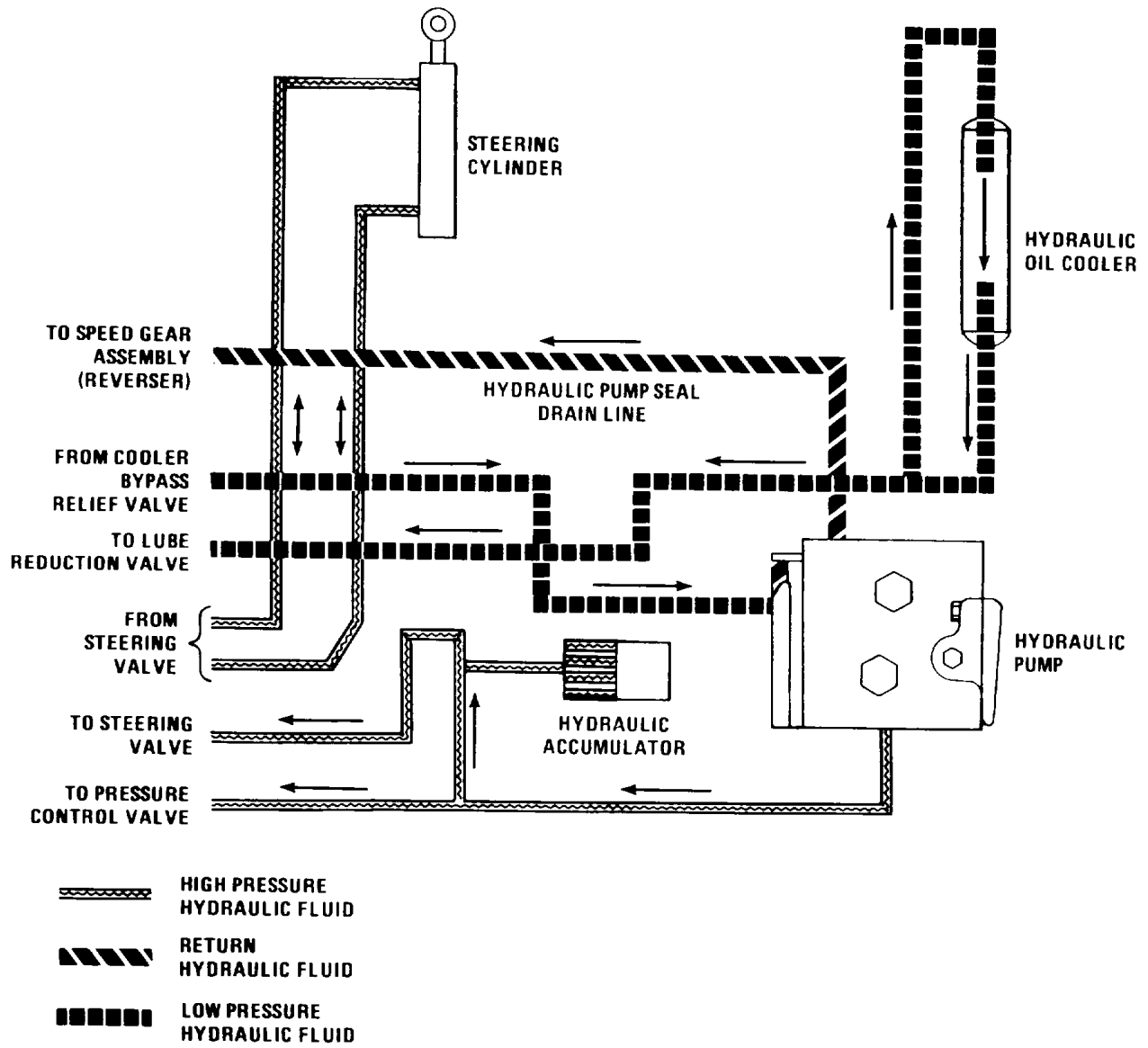

Section XXI. GAGES (NON-ELECTRICAL), WEIGHING AND MEASURING DEVICES

	Page		Page
Air Cleaner Restriction Indicator	2-1792	Tachometer	2-1785
		Tachometer Drive Cable	2-1789

TACHOMETER

This task covers:

- | | |
|---|-------------------------------|
| a. Removal (page 2-1786) | d. Repair (page 2-1788) |
| b. Cleaning (page 2-1786) | e. Installation (page 2-1788) |
| c. Inspection/Replacement (page 2-1787) | |
-

INITIAL SETUP

Tools

Handle, ratchet, 1/4-inch drive
 Pliers, slip-joint
 Socket, 1/4-inch, 3/8-inch
 Threading set, screw

Materials/Parts

Nut, assembled washer (two required)
 Packing, tachometer
 Rags, wiping (item 21, Appendix C)
 Solvent, drycleaning
 (item 28, Appendix C)

Personnel Required

One

Equipment Condition

1. Loader bucket support installed (page 2-1830)
2. Cowl front cover removed (page 2-1020)
3. Plexiglas dash cover removed (page 2-576)
4. Dash light removed (page 2-554)

2-1785

TACHOMETER - CONTINUED

LOCATION	ITEM	ACTION	REMARKS
REMOVAL			
1.	Tachometer (1) and packing (2)	Drive cable (3)	Using slip-joint pliers, unscrew and take off.
2.	Tachometer (1)	Packing (2)	a. Take off. b. Get rid of.
3.	Tachometer (1) and bracket (4) off.	Two assembled washer nuts (5)	a. Using 3/8-inch, 1/4-inch drive socket and ratchet handle, unscrew and take off. b. Get rid of.
4.	Tachometer (1)	Bracket (4)	Take off.
5.	Dash (6)	Tachometer (1)	Take out.

CLEANING

NOTE

For more information on how to clean parts, go to **General Maintenance Instructions (page 2-137)**.

WARNING

Drycleaning solvent P-D-680 is toxic and flammable. Wear protective goggles and gloves and use only in a well ventilated area. Avoid contact with skin, eyes, and clothes and don't breathe vapors. Do not use near open flame or excessive heat. The flashpoint is 100°F to 138°F (38° to 59°C). If you become dizzy while using cleaning solvent, get fresh air immediately and get medical aid. If contact with eyes is made, wash your eyes with water and get medical aid immediately.

6.	Tachometer (1)	a. Using clean, dry rag dampened in drycleaning solvent, wipe clean. b. Using clean, dry rag, wipe dry.
7.	All other parts	a. Clean in drycleaning solvent. b. Using clean, dry rag, wipe dry.

TACHOMETER - CONTINUED

LOCATION	ITEM	ACTION	REMARKS
----------	------	--------	---------

INSPECTION/REPLACEMENT

NOTE

For more information on how to inspect parts, go to General Maintenance Instructions (page 2-137).

Replace defective parts which cannot be repaired.

- | | | |
|-----|------------------|--|
| 8. | All metal parts | Look for cracks, breaks, and abnormal bends. |
| 9. | All thread parts | Look for damaged threads. |
| 10. | Tachometer (1) | Look for cracks, dents, and unreadable dial. |

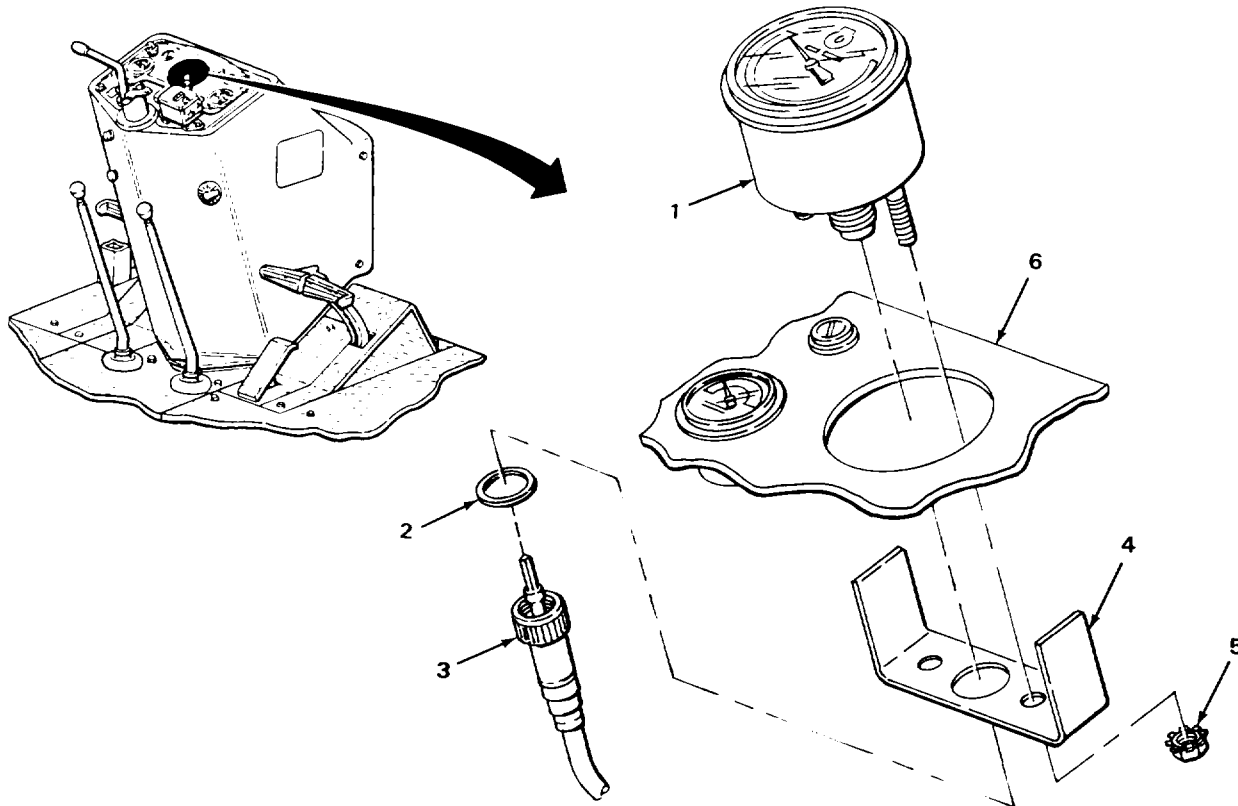

TA243591

TACHOMETER - CONTINUED

LOCATION	ITEM	ACTION	REMARKS
REPAIR			
11.	Tachometer (1)		If threads are damaged, using screw threading set, restore threads.
INSTALLATION			
12. Dash (2)	Tachometer (1)		Place in position.
13. Tachometer (1)	Bracket (3)		Place in position.
14. Tachometer (1) and bracket (3)	Two new assembled washer nuts (4)		Screw on and tighten using 3/8-inch, 1/4-inch drive socket and ratchet handle.
15. Tachometer (1)	New packing (5)		Place in position.
16. Tachometer (1) and packing (5)	Drive cable (6)		Screw on and tighten using slip-joint pliers.

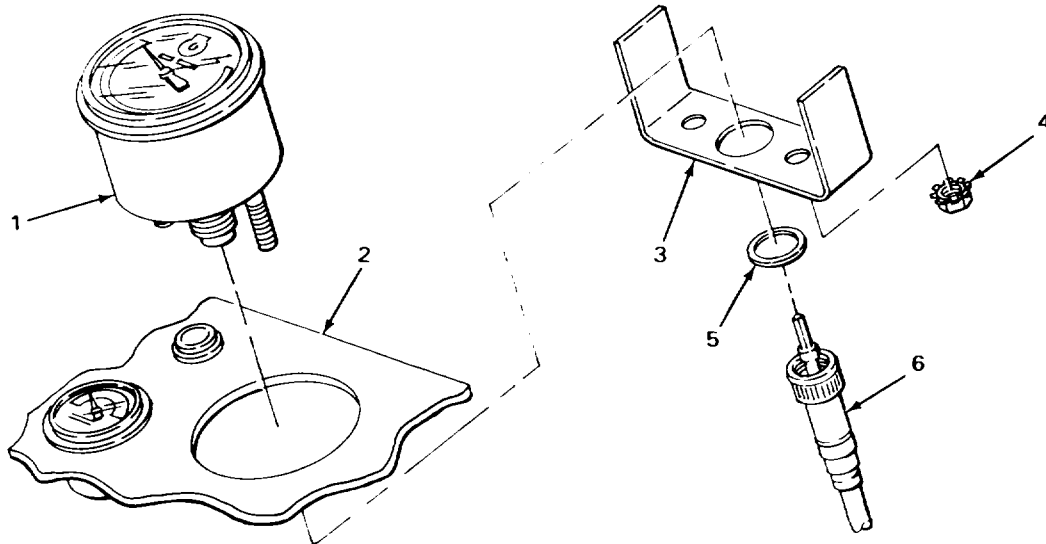

TACHOMETER - CONTINUED

LOCATION	ITEM	ACTION	REMARKS
----------	------	--------	---------

NOTE
FOLLOW-ON MAINTENANCE:

1. Install dash light (page 2-554).
2. Install plexiglass dash cover (page 2-576).
3. Install cowl front cover (page 2-1020).
4. Install loader bucket support (page 2-1830).

TASK ENDS HERE

TACHOMETER DRIVE CABLE

This task covers:

- | | |
|---------------------------|---|
| a. Removal (page 2-1790) | c. Inspection/Replacement (page 2-1790) |
| b. Cleaning (page 2-1790) | d. Installation (page 2-1790) |

INITIAL SETUP

Tools

Pliers, slip-joint, multiple tongue and groove

Materials/Parts

Gasket, tachometer drive
Rags, wiping (item 21, Appendix C)

Personnel Required

One

Equipment Condition

1. Loader bucket support installed (page 2-1830)
2. Cowl front cover removed (page 2-1020)
3. Right outer platform ramp removed (page 2-1088)

LOCATION	ITEM	ACTION	REMARKS
REMOVAL			
1.	Tachometer (1)	Drive cable (2)	Using multiple tongue and groove slip-joint pliers, unscrew and take off.
2.	Reverser housing (3) and gasket (4)	Drive cable (2)	Using multiple tongue and groove slip-joint pliers, unscrew and take off.
3.	Reverser housing (3)	Gasket (4)	a. Take off. b. Get rid of.
CLEANING			
NOTE			
For more information on how to clean parts, go to General Maintenance Instructions (page 2-137).			
4.	Drive cable (2)	Using clean, dry rag, wipe clean.	
INSPECTION/REPLACEMENT			
NOTE			
For more information on how to inspect parts, go to General Maintenance Instructions (page 2-137).			
Replace defective parts as needed.			
5.		Drive cable (2)	Look for cracks, breaks, and abnormal bends.
INSTALLATION			
6.	Reverser housing (3)	New gasket (4)	Place in position.
7.	Reverser housing (3) and gasket (4)	Drive cable (2)	Screw in and tighten using multiple tongue and groove slip-joint pliers.
8.	Tachometer (1)	Drive cable (2)	Screw in and tighten using multiple tongue and groove slip-joint pliers.

TACHOMETER DRIVE CABLE - CONTINUED

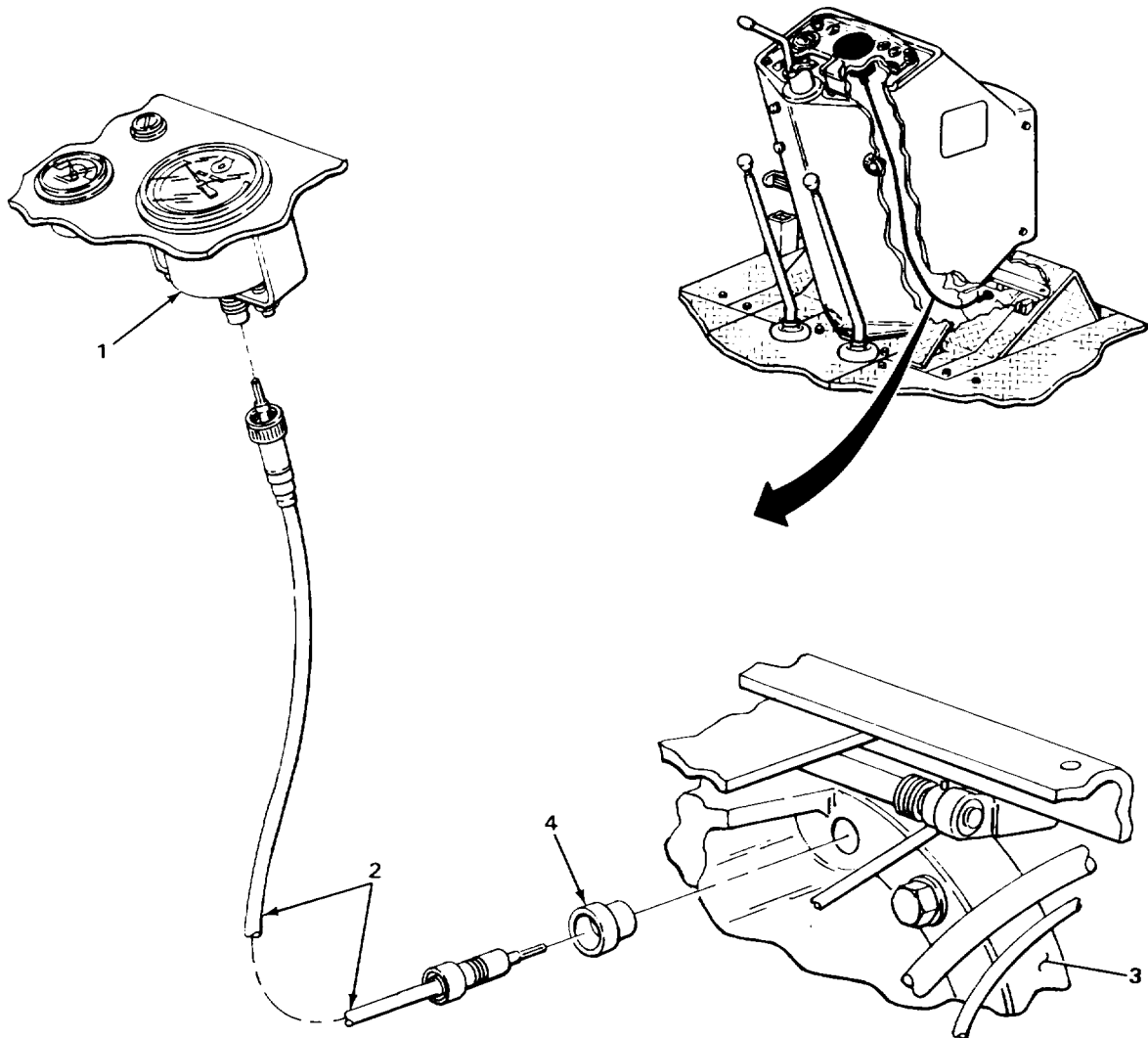

NOTE

FOLLOW-ON MAINTENANCE:

1. Install right outer platform ramp (page 2-1088).
2. Install cowl front cover (page 2-1020).
3. Remove loader bucket support (page 2-1830).

TASK ENDS HERE

TA243593

AIR CLEANER RESTRICTION INDICATOR

JAW DIRECT LINEAR VALVE (SERIAL NUMBERS 319995 THRU 342573 ONLY)

This task covers:

- a. Removal (page 2-1792)
- b. Cleaning (page 2-1792)
- c. Inspection/Replacement (page 2-1793)
- d. Installation (page 2-1794)

INITIAL SETUP

<p>Tools</p> <p>Wrench, open-end, 7/16-inch</p>	<p>Personnel Required</p> <p>One</p>
<p>Materials/Parts</p> <p>Rags, wiping (item 21, Appendix C) Solvent, drycleaning (item 28, Appendix C)</p>	<p>Equipment Condition</p> <p>Left side grille removed (TM 5-2420-222-10)</p>

LOCATION	ITEM	ACTION	REMARKS
----------	------	--------	---------

REMOVAL

- | | | | |
|----|-----------------|---------------------------|--|
| 1. | Connector (1) | Restriction indicator (2) | Unscrew and take off. |
| 2. | Air cleaner (3) | Connector (1) | Using 7/16-inch open-end wrench, unscrew and take out. |

CLEANING

NOTE

For more information on how to clean parts, go to **General Maintenance Instructions (page 2-137)**.

- | | | |
|----|---------------------------|-----------------------------------|
| 3. | Restriction indicator (2) | Using clean, dry rag, wipe clean. |
|----|---------------------------|-----------------------------------|

WARNING

Drycleaning solvent P-D-680 is toxic and flammable. Wear protective goggles and gloves and use only in a well ventilated area. Avoid contact with skin, eyes, and clothes and don't breathe vapors. Do not use near open flame or excessive heat. The flashpoint is 100°F to 138°F (38° to 59°C). If you become dizzy while using cleaning solvent, get fresh air immediately and get medical aid. If contact with eyes is made, wash your eyes with water and get medical aid immediately.

- | | | |
|----|---------------|--|
| 4. | Connector (1) | <ul style="list-style-type: none"> a. Clean in drycleaning solvent. b. Using clean, dry rag, wipe dry. |
|----|---------------|--|

AIR CLEANER RESTRICTION INDICATOR - CONTINUED

LOCATION	ITEM	ACTION	REMARKS
----------	------	--------	---------

INSPECTION/REPLACEMENT

NOTE

For more information on how to inspect parts, go to **General Maintenance Instructions (page 2-137)**.

Replace defective parts as needed.

- | | | |
|----|---------------------------|---|
| 5. | Restriction indicator (2) | <ul style="list-style-type: none"> a. Look for cracks, breaks, and damaged threads. b. Make sure reset button (4) moves freely. |
| 6. | Connector (1) | Look for cracks, breaks, bends, and damaged threads. |

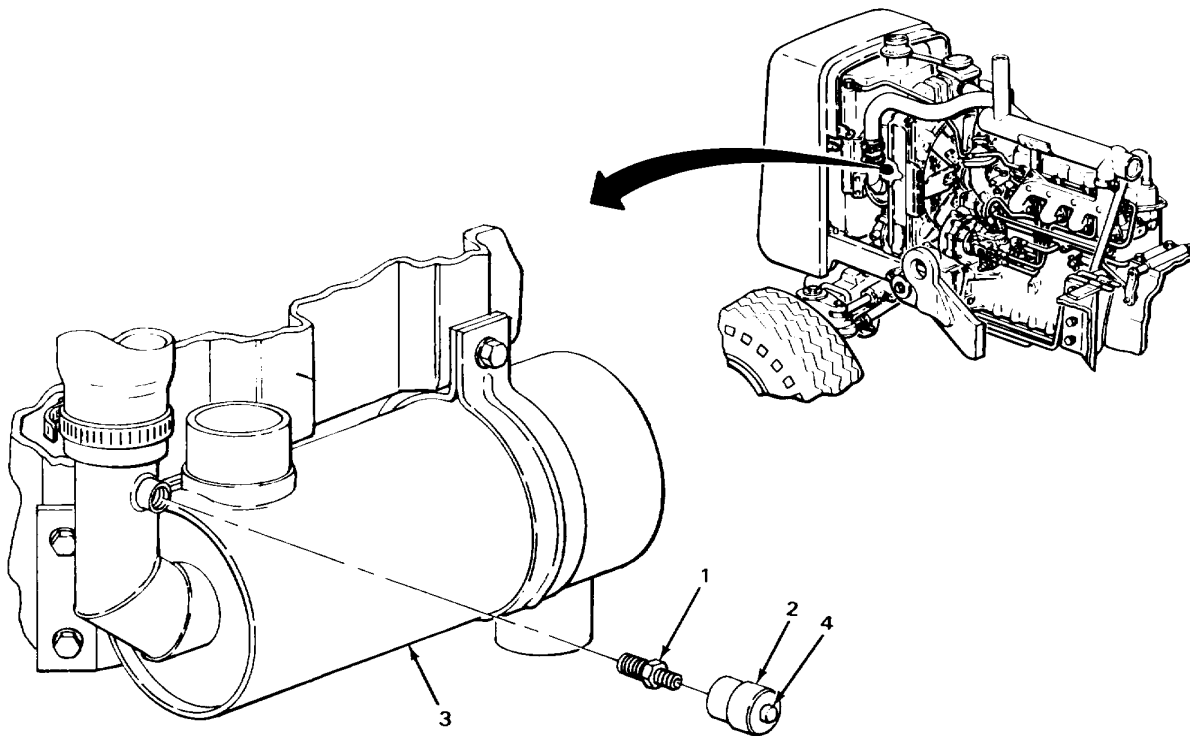

TA243594

AIR CLEANER RESTRICTION INDICATOR - CONTINUED

LOCATION	ITEM	ACTION	REMARKS
INSTALLATION			
7.	Air cleaner (1)	Connector (2)	Screw in and tighten using 7/16-inch open-end wrench.
8.	Connector (2)	Restriction indicator (3)	Screw on and tighten.
9.	Restriction indicator (3)	Reset button (4)	Push in to reset.

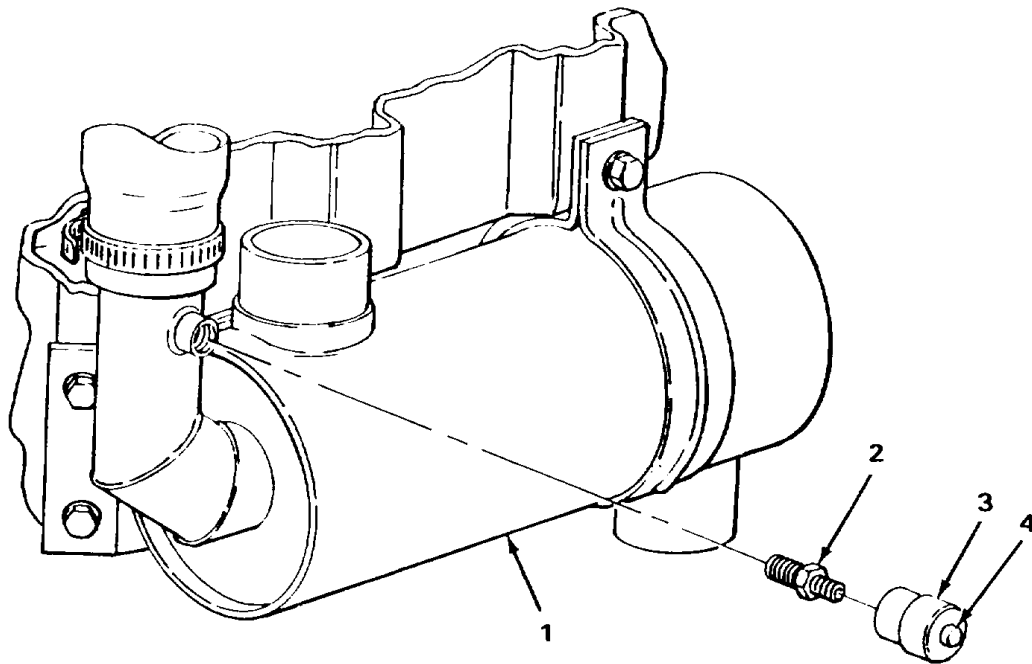

NOTE

FOLLOW-ON MAINTENANCE: Install left side grille (TM 52420-222-10).

TASK ENDS HERE

TA243595

Section XXII. CRANES, SHOVELS, AND EARTHMOVING EQUIPMENT COMPONENTS

	Page		Page
Backhoe Bucket	2-1795	Loader Bucket	2-1833
Backhoe Bucket Linkage	2-1818	Loader Bucket Level Indicator	2-1838
Backhoe Bucket Teeth.....	2-1815	Loader Bucket Linkage.....	2-1844
Backhoe Dipperstick Hose Guards.....		Loader Bucket Support.....	2-1830
(Serial Numbers 319995 thru 342573 Only).....	2-1826		

BACKHOE BUCKET

This task covers:

- | | |
|--|-------------------------------|
| a. Removal (page 2-1796) | e. Repair (page 2-1804) |
| b. Disassembly (page 2-1798) | f. Assembly (page 2-1804) |
| c. Cleaning (page 2-1803) | g. Installation (page 2-1806) |
| d. Inspection/Replacement(page 2-1804) | h. Adjustment (page 2-1810) |
-

INITIAL SETUP

Tools

- Blocks, wood
- Container, flexible, 1-gallon
- Driftpin, brass-tipped, 3/4-inch
- Extension, 1/4-inch drive, 3-inch
- Hammer, ball-peen, 2-pound head
- Handle, ratchet, 1/4-inch drive
- Lifting equipment, 1000-pound capacity
- Lifting equipment, 2000-pound capacity
- Pliers, long roundnose
- Puller kit, mechanical, slide hammer type
- Punch, drive-pin, straight, 1/4-inch
- Remover and installer, 1 13/16-inch
- Remover and installer, 1 7/8-inch
- Remover and installer, 2 1/8-inch
- Socket, 1/4-inch drive, 5/16-inch
- Wrench, open-end, 7/8-inch
- Wrench, open-end, 1-inch

NOTE

The following tool only applies to loader backhoes with linkage pins retained by retaining rings.

Pliers, retaining ring

Tools - Continued

NOTE

The following tool only applies to loader backhoes with linkage pins retained by cotter pins.

Pliers, slip-joint, multiple tongue and groove

Materials/Parts

- Pin, cotter, clevis pin (two required)
- Rags, wiping (item 21, Appendix C)
- Solvent, drycleaning (item 28, Appendix C)

NOTE

The following parts only apply to loader backhoes with linkage pins retained by cotter pins.

- Pin, cotter, coupler link (two required)
- Pin, cotter, dipperstick (two required)
- Pin, cotter, guide link

BACKHOE BUCKET - CONTINUED**INITIAL SET UP - CONTINUED**

Personnel Required

Two

Equipment Condition

Jaw cylinder oil hoses removed (page 2-1544)

LOCATION	ITEM	ACTION	REMARKS
----------	------	--------	---------

REMOVAL

- | | | | |
|----|------------------------|---------------------|---|
| 1. | Two union adapters (1) | Two hoses (2 and 3) | <ul style="list-style-type: none"> a. Place 1-gallon flexible container underneath. b. Using 7/8-inch and 1-inch open-end wrenches, loosen. |
| 2. | Loader backhoe | Inner bucket (4) | Place wood blocks in front of. |

WARNING

Some parts are heavy. Be careful when handling them. Lifting equipment is needed when parts weigh over 50 pounds (23 kg) for a single person lift, over 100 pounds (45 kg) for a two person lift, and over 150 pounds (68 kg) for a three or more person lift. Do not try to handle heavy parts without lifting equipment. Keep clear of heavy parts supported only by lifting equipment. Failure to observe this precaution could cause serious injury or death of personnel.

- | | | | |
|----|--|----------|--|
| 3. | | Boom (5) | Using 2000-pound capacity lifting equipment, support to take pressure off two pins (6 and 7) or (8 and 9). |
|----|--|----------|--|

NOTE

Some loader backhoes have linkage pins retained by cotter pins, some have pins retained by retaining rings. For loader backhoes equipped with retaining rings, skip steps 4 and 5.

- | | | | |
|----|---|----------------------------------|---|
| 4. | Two pins (6 and 7) and four special washers (10 and 11) | Four cotter pins (12 and 13) | <ul style="list-style-type: none"> a. Using multiple tongue and groove slip-joint pliers, straighten ends. b. Using 1/4-inch straight drive-pin punch and 2-pound head ball-peen hammer, drive out. c. Get rid of. |
| 5. | Two pins (6 and 7) and inner bucket (4) | Four special washers (10 and 11) | Take off. |

BACKHOE BUCKET - CONTINUED

LOCATION	ITEM	ACTION	REMARKS
6. Two pins (8 and 9) and inner bucket (4)	Four retaining rings (14 and 15) off.	On loader backhoes equipped with retaining rings, using retaining ring pliers, take	
7. Dipperstick (16), inner bucket (4), and two bushings (17)	Pin (6 or 8)	Using 3/4-inch brass-tipped driftpin and 2-pound head ball-peen hammer, drive	out.

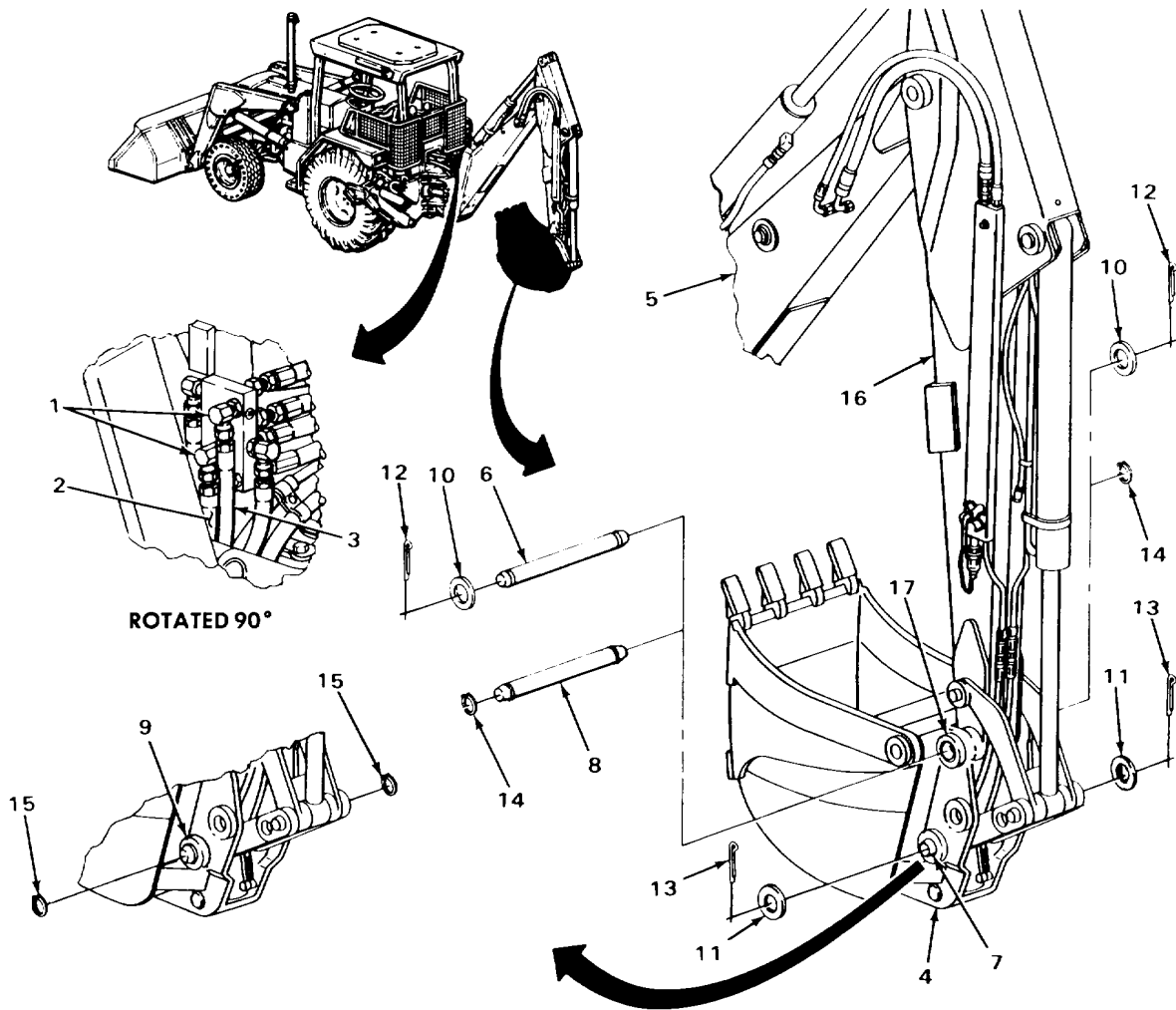

TA243596

BACKHOE BUCKET - CONTINUED

LOCATION	ITEM	ACTION	REMARKS
REMOVAL - CONTINUED			
8.	Two coupler links (1), inner bucket (2), two bushings (3), and spacer (4)	Pin (5 or 6)	Using 3/4-inch brass-tipped driftpin and 2-pound head ball-peen hammer, drive out.
9.	Inner bucket (2) and two coupler links (1)	Spacer (4)	Take out.

WARNING

Some parts are heavy. Be careful when handling them. Lifting equipment is needed when parts weigh over 50 pounds (23 kg) for a single person lift, over 100 pounds (45 kg) for a two person lift, and over 150 pounds (68 kg) for a three or more person lift. Do not try to handle heavy parts without lifting equipment. Keep clear of heavy parts supported only by lifting equipment. Failure to observe this precaution could cause serious injury or death of personnel.

10.	Inner bucket (2)	Boom (7), two coupler links (1) and dipperstick (8)	Using 2000-pound capacity lifting equipment, lift clear.
11.	Dipperstick (8)	Inner bucket (2) with assembled jaw (9)	With aid of assistant, slide clear.
12.	Boom (7)	Dipperstick (8)	<ol style="list-style-type: none"> Place wood blocks underneath. Using 2000-pound capacity lifting equipment, lower until resting firmly on wood blocks. Take off 2000-pound capacity lifting equipment.

DISASSEMBLY**CAUTION**

Do not remove bushings unless inspection shows need for replacement. Removal may damage parts.

13.	Inner bucket (2)	Two bushings (3)	Using 2 1/8inch remover and installer and 2-pound head ball-peen hammer, drive out.
-----	------------------	------------------	---

BACKHOE BUCKET - CONTINUED

LOCATION	ITEM	ACTION	REMARKS
14.	Two bushings (10)	Using 1 7/8-inch remover and installer and 2-pound head ball-peen hammer, drive out.	
15. Jaw and inner bucket	Jaw cylinder	Remove (page 2-1703).	

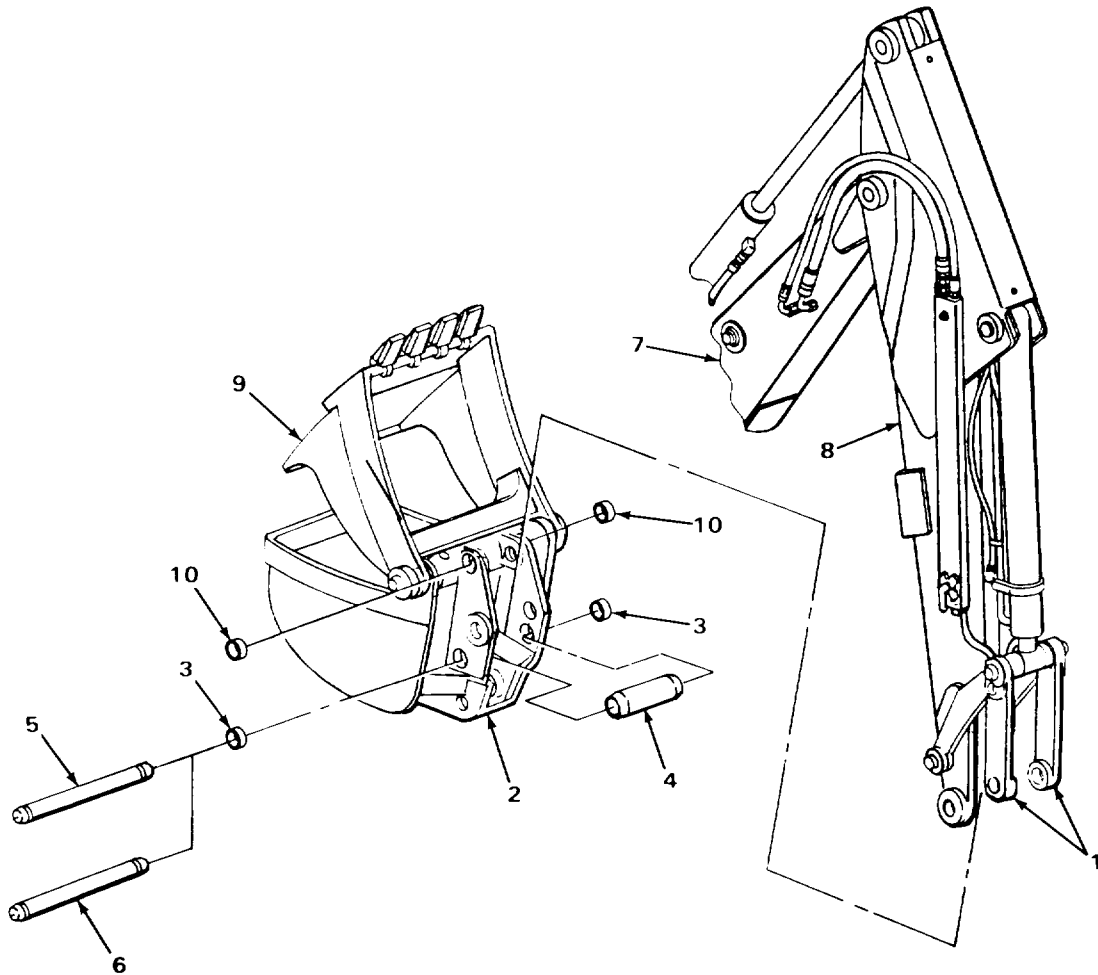

BACKHOE BUCKET - CONTINUED

LOCATION	ITEM	ACTION	REMARKS
----------	------	--------	---------

DISASSEMBLY - CONTINUED

WARNING

Some parts are heavy. Be careful when handling them. Lifting equipment is needed when parts weigh over 50 pounds (23 kg) for a single person lift, over 100 pounds (45 kg) for a two person lift, and over 150 pounds (68 kg) for a three or more person lift. Do not try to handle heavy parts without lifting equipment. Keep clear of heavy parts supported only by lifting equipment. Failure to observe this precaution could cause serious injury or death of personnel.

- | | | | |
|-----|---|---------------------------|--|
| 16. | Inner bucket (1) | Jaw (2) | <ol style="list-style-type: none"> Using 1000-pound capacity lifting equipment, lift until two clevis pins (3 and 4) are accessible. Place wood blocks in position to support. Using 1000-pound capacity lifting equipment, lower onto wood blocks. |
| 17. | Two clevis pins (3 and 4) | Two cotter pins (5 and 6) | <ol style="list-style-type: none"> Using long roundnose pliers, straighten ends and take out. Get rid of. |
| 18. | Two pins (7 and 8) and inner bucket (1) | Two clevis pins (3 and 4) | <ol style="list-style-type: none"> Using 2-pound head ball-peen hammer and 3/4-inch brass-tipped driftpin, break loose. Using 1/4-inch straight drive-pin punch and 2-pound head ball-peen hammer, drive out. |

WARNING

Some parts are heavy. Be careful when handling them. Lifting equipment is needed when parts weigh over 50 pounds (23 kg) for a single person lift, over 100 pounds (45 kg) for a two person lift, and over 150 pounds (68 kg) for a three or more person lift. Do not try to handle heavy parts without lifting equipment. Keep clear of heavy parts supported only by lifting equipment. Failure to observe this precaution could cause serious injury or death of personnel.

- | | | | |
|-----|------------------|---------|--|
| 19. | Inner bucket (1) | Jaw (2) | <ol style="list-style-type: none"> Using 1000-pound capacity lifting equipment, lift off wood blocks. Take out wood blocks. Using 1000-pound capacity lifting equipment, lower. |
|-----|------------------|---------|--|

BACKHOE BUCKET - CONTINUED

LOCATION	ITEM	ACTION	REMARKS
20. Two pins (7 and 8) and inner bucket (1)	Two clevis pins (3 and 4)	a. Using 2-pound head ball-peen hammer and 3/4-inch brass-tipped driftpin, break loose. b. Using 1/4-inch straight drive-pin punch and 2-pound head ball-peen hammer, drive out.	

WARNING

Some parts are heavy. Be careful when handling them. Lifting equipment is needed when parts weigh over 50 pounds (23 kg) for a single person lift, over 100 pounds (45 kg) for a two person lift, and over 150 pounds (68 kg) for a three or more person lift. Do not try to handle heavy parts without lifting equipment. Keep clear of heavy parts supported only by lifting equipment. Failure to observe this precaution could cause serious injury or death of personnel.

21. Inner bucket (1)	Jaw (2)	a. Using 1000-pound capacity lifting equipment, lift off wood blocks. b. Take out wood blocks. c. Using 1000-pound capacity lifting equipment, lower.	
----------------------	---------	---	--

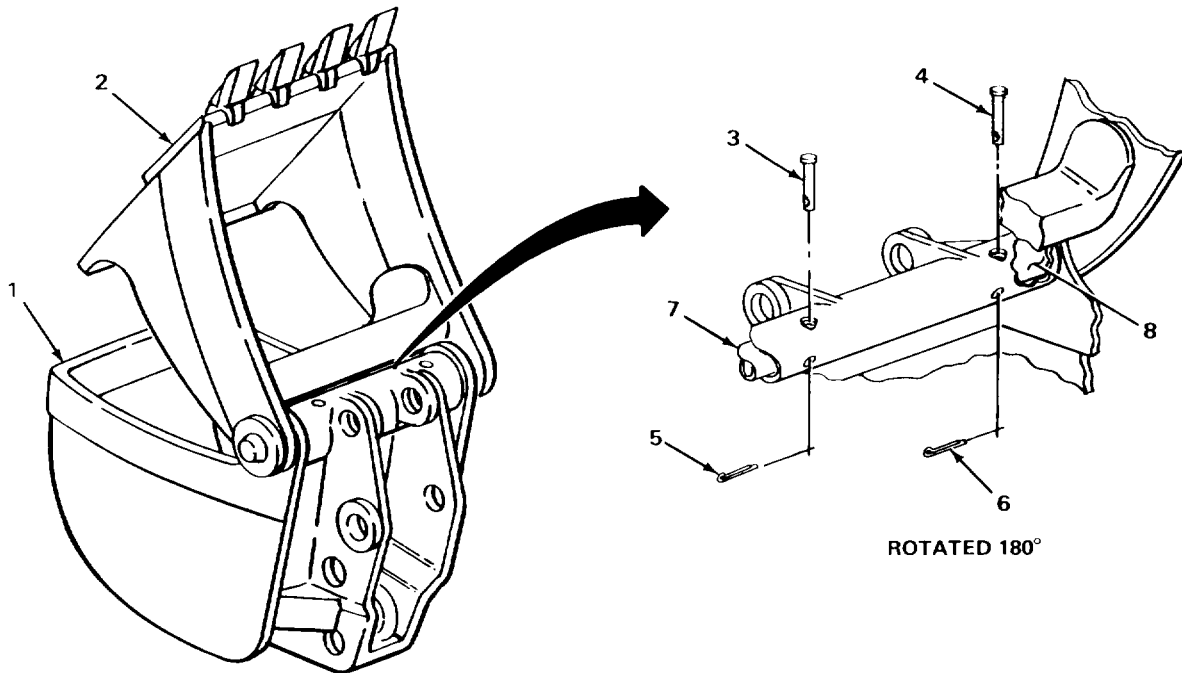

TA243598

BACKHOE BUCKET - CONTINUED

LOCATION	ITEM	ACTION	REMARKS
DISASSEMBLY - CONTINUED			
22.	Two pins (1 and 2)	Two grease fittings (3 and 4)	Using 5/16-inch, 1/4-inch drive socket, 3-inch extension, and ratchet handle, unscrew and take out.
23.	Inner bucket (5), jaw (6), and washer (7)	Two pins (1 and 2)	Using slide hammer type mechanical puller kit, take out.
24.	Inner bucket (5) and jaw (6)	Washer (7)	a. Note position for proper placement during assembly. b. Take out.

WARNING

Some parts are heavy. Be careful when handling them. Lifting equipment is needed when parts weigh over 50 pounds (23 kg) for a single person lift, over 100 pounds (45 kg) for a two person lift, and over 150 pounds (68 kg) for a three or more person lift. Do not try to handle heavy parts without lifting equipment. Keep clear of heavy parts supported only by lifting equipment. Failure to observe this precaution could cause serious injury or death of personnel.

25.	Inner bucket (5)	Jaw (6)	a. With aid of assistant using 1000-pound capacity lifting equipment, lift off and set on wood blocks. b. Take off 1000-pound capacity lifting equipment.
-----	------------------	---------	--

CAUTION

Do not remove bushings unless inspection shows need for replacement. Removal may damage parts.

26.	Jaw (6)	Two bushings (8 and 9)	Using 1 13/16-inch remover and installer and 2-pound head ball-peen hammer, drive out.
27.	Backhoe bucket teeth	Remove (page 2-1815).	

BACKHOE BUCKET - CONTINUED

LOCATION	ITEM	ACTION	REMARKS
----------	------	--------	---------

CLEANING

NOTE

For more information on how to clean parts, go to General Maintenance Instructions (page 2-137).

WARNING

Dry-cleaning solvent P-D-680 is toxic and flammable. Wear protective goggles and gloves and use only in a well ventilated area. Avoid contact with skin, eyes, and clothes and don't breathe vapors. Do not use near open flame or excessive heat. The flashpoint is 100°F to 138°F (38° to 59°C). If you become dizzy while using cleaning solvent, get fresh air immediately and get medical aid. If contact with eyes is made, wash your eyes with water and get medical aid immediately.

- | | | |
|-----|---------------------------------|--|
| 28. | Inner bucket (5)
and jaw (6) | <ul style="list-style-type: none"> a. Using clean rags dampened in dry-cleaning solvent, wipe clean. b. Using clean, dry rags, wipe dry. |
|-----|---------------------------------|--|

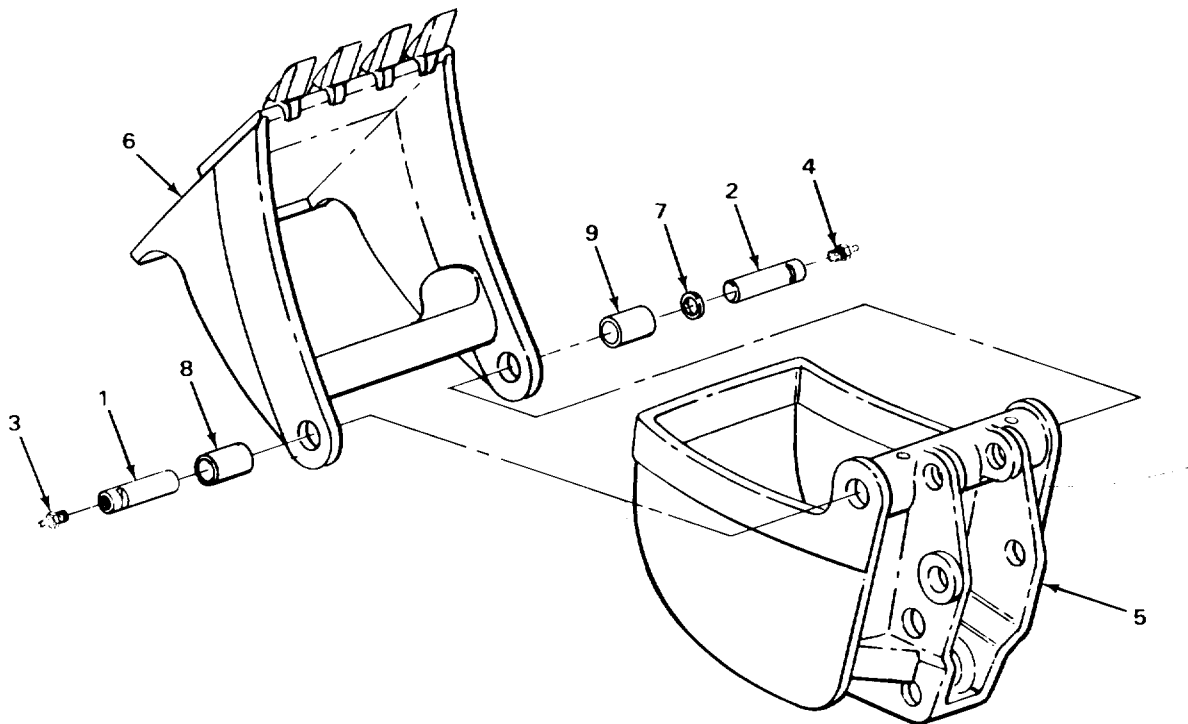

TA243599

BACKHOE BUCKET - CONTINUED

LOCATION	ITEM	ACTION	REMARKS
----------	------	--------	---------

CLEANING - CONTINUED

WARNING

Drycleaning solvent P-D-680 is toxic and flammable. Wear protective goggles and gloves and use only in a well ventilated area. Avoid contact with skin, eyes, and clothes and don't breathe vapors. Do not use near open flame or excessive heat. The flashpoint is 100°F to 138°F (38° to 59°C). If you become dizzy while using cleaning solvent, get fresh air immediately and get medical aid. If contact with eyes is made, wash your eyes with water and get medical aid immediately.

- | | | | |
|-----|-----------------------|--|--|
| 29. | All other metal parts | a. Clean in dry-cleaning solvent.
b. Using clean, dry rags, wipe dry. | |
|-----|-----------------------|--|--|

INSPECTION/REPLACEMENT

NOTE

For more information on how to inspect parts, go to General Maintenance Instructions (page 2-137).

Replace defective parts which cannot be repaired.

- | | | | |
|-----|--------------------|--|--|
| 30. | All metal parts | Look for cracks, breaks, and abnormal bends. | |
| 31. | All bushings | Look for excessive wear. | |
| 32. | All threaded parts | Look for damaged threads. | |

REPAIR

- | | | | |
|-----|----------------------|---|--|
| 33. | Inner bucket and jaw | If cracks, breaks, or broken welds are found, repair by welding (TM 9-237). | |
|-----|----------------------|---|--|

ASSEMBLY

- | | | | |
|-----|---------|------------------------|---|
| 34. | Jaw (1) | Backhoe bucket teeth | Install (page 2-1815). |
| 35. | | Two bushings (2 and 3) | If removed, using 1 13/16-inch remover and installer and 2-pound head ball-peen hammer, tap in. |

BACKHOE BUCKET - CONTINUED

LOCATION	ITEM	ACTION	REMARKS
----------	------	--------	---------

WARNING

Some parts are heavy. Be careful when handling them. Lifting equipment is needed when parts weigh over 50 pounds (23 kg) for a single person lift, over 100 pounds (45 kg) for a two person lift, and over 150 pounds (68 kg) for a three or more person lift. Do not try to handle heavy parts without lifting equipment. Keep clear of heavy parts supported only by lifting equipment. Failure to observe this precaution could cause serious injury or death of personnel.

- | | | | |
|-----|---|--------------------|--|
| 36. | Inner bucket (4) | Jaw (1) | With aid of assistant, using 1000-pound capacity lifting equipment, place in position and support alining pin holes. |
| 37. | Inner bucket (4) and jaw (1) | Washer (5) | Place in position as noted during |
| 38. | Inner bucket (4), jaw (1), and washer (5) | Two pins (6 and 7) | Using 2-pound head ball-peen hammer and wood block, tap in, alining grooves with holes in inner bucket (4). |

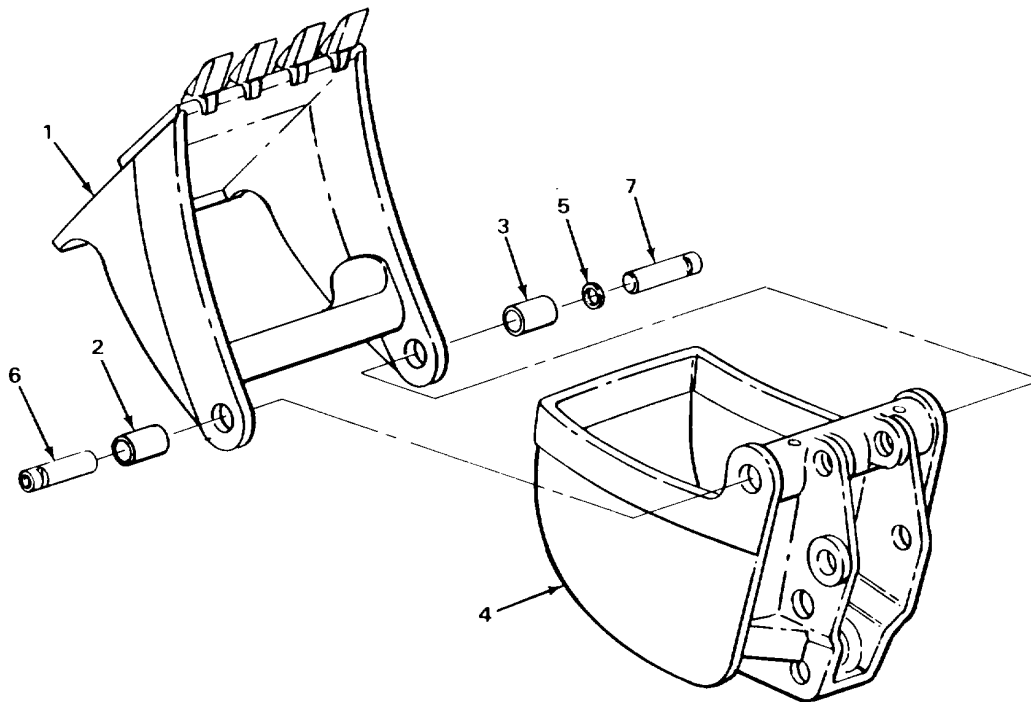

BACKHOE BUCKET - CONTINUED

LOCATION	ITEM	ACTION	REMARKS
ASSEMBLY - CONTINUED			
WARNING			
Some parts are heavy. Be careful when handling them. Lifting equipment is needed when parts weigh over 50 pounds (23 kg) for a single person lift, over 100 pounds (45 kg) for a two person lift, and over 150 pounds (68 kg) for a three or more person lift. Do not try to handle heavy parts without lifting equipment. Keep clear of heavy parts supported only by lifting equipment. Failure to observe this precaution could cause serious injury or death of personnel.			
39.	Two pins (1 and 2) and inner bucket (3)	Two clevis pins (4 and 5)	Using 2-pound head ball-peen hammer, tap in.
40.	Two clevis pins (4 and 5)	Two new cotter pins (6 and 7)	a. Push in. b. Using long roundnose pliers, bend ends back. c. Take 1000-pound capacity lifting equipment off jaw (8).
41.	Two pins (1 and 2)	Two grease fittings (9 and 10)	Screw in and tighten using 5/16-inch, 1/4-inch drive socket, 3-inch extension, and ratchet handle.
42.	Jaw and inner bucket	Jaw cylinder	Install (page 2-1703).
43.	Inner bucket (3)	Two bushings (11)	If removed, using 2 1/8-inch remover and installer and 2-pound head ball-peen hammer, tap in.
44.		Two bushings (12)	If removed, using 1 7/8-inch remover and installer and 2-pound head ball-peen hammer, tap in.

INSTALLATION

WARNING

Some parts are heavy. Be careful when handling them. Lifting equipment is needed when parts weigh over 50 pounds (23 kg) for a single person lift, over 100 pounds (45 kg) for a two person lift, and over 150 pounds (68 kg) for a three or more person lift. Do not try to handle heavy parts without lifting equipment. Keep clear of heavy parts supported only by lifting equipment. Failure to observe this precaution could cause serious injury or death of personnel.

BACKHOE BUCKET - CONTINUED

LOCATION	ITEM	ACTION	REMARKS
45. Boom (13)	Dipperstick (14)	a. Using 2000-pound capacity lifting equipment, lift high enough to clear inner bucket (3) with assembled jaw (8). b. Take out wood blocks.	
46. Dipperstick (14)	Inner bucket (3) with assembled jaw (8)	With aid of assistant, slide underneath dipperstick (14).	

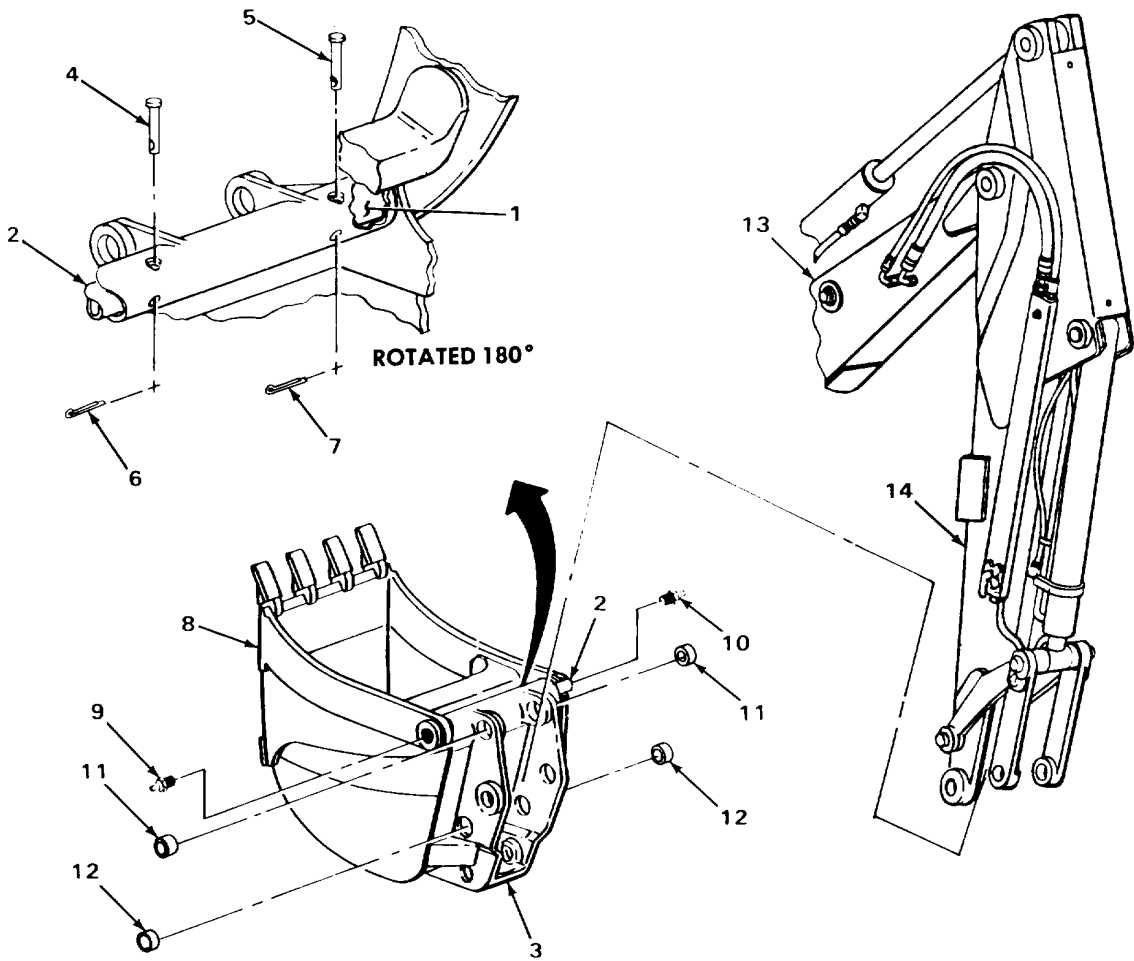

BACKHOE BUCKET - CONTINUED

LOCATION	ITEM	ACTION	REMARKS
----------	------	--------	---------

INSTALLATION - CONTINUED

WARNING

Some parts are heavy. Be careful when handling them. Lifting equipment is needed when parts weigh over 50 pounds (23 kg) for a single person lift, over 100 pounds (45 kg) for a two person lift, and over 150 pounds (68 kg) for a three or more person lift. Do not try to handle heavy parts without lifting equipment. Keep clear of heavy parts supported only by lifting equipment. Failure to observe this precaution could cause serious injury or death of personnel.

47.	Inner bucket (1)	Boom (2), two coupler links (3), and dipperstick (4)	With aid of assistant, using 2000-pound capacity lifting equipment, lower into position and support aligning pin holes.
48.	Inner bucket (1) and two coupler links (3)	Spacer (5)	Place in position.
49.	Two coupler links (3), inner bucket (1), two bushings (6), and spacer (5)	Pin (7 or 8)	Using 2-pound head ball-peen hammer, tap in.
50.	Dipperstick (4), inner bucket (1), and two bushings (9)	Pin (10 or 11)	Using 2-pound head ball-peen hammer, tap in.

NOTE

Some loader backhoes have linkage pins retained by cotter pins, some have pins retained by retaining rings. For loader backhoes equipped with retaining rings, skip steps 51 and 52.

51.	Two pins (7 and 10) and inner bucket (1)	Four special washers (12 and 13)	Put on.
52.	Two pins (7 and 10) and four special washers (12 and 13)	Four new cotter pins (14 and 15)	<ol style="list-style-type: none"> a. Push in. b. Using multiple tongue and groove slip-joint pliers, bend ends back.

BACKHOE BUCKET - CONTINUED

LOCATION	ITEM	ACTION	REMARKS
53. Two pins (8 and 11) and inner bucket (1)	Four rings (16 and 17)	a. On loader backhoes equipped with retaining rings, using retaining ring pliers, put on. b. Take 2000-pound capacity lifting equipment off boom (2).	
54. Jaw cylinder	Jaw cylinder oil hoses	Install (page 2-1544).	

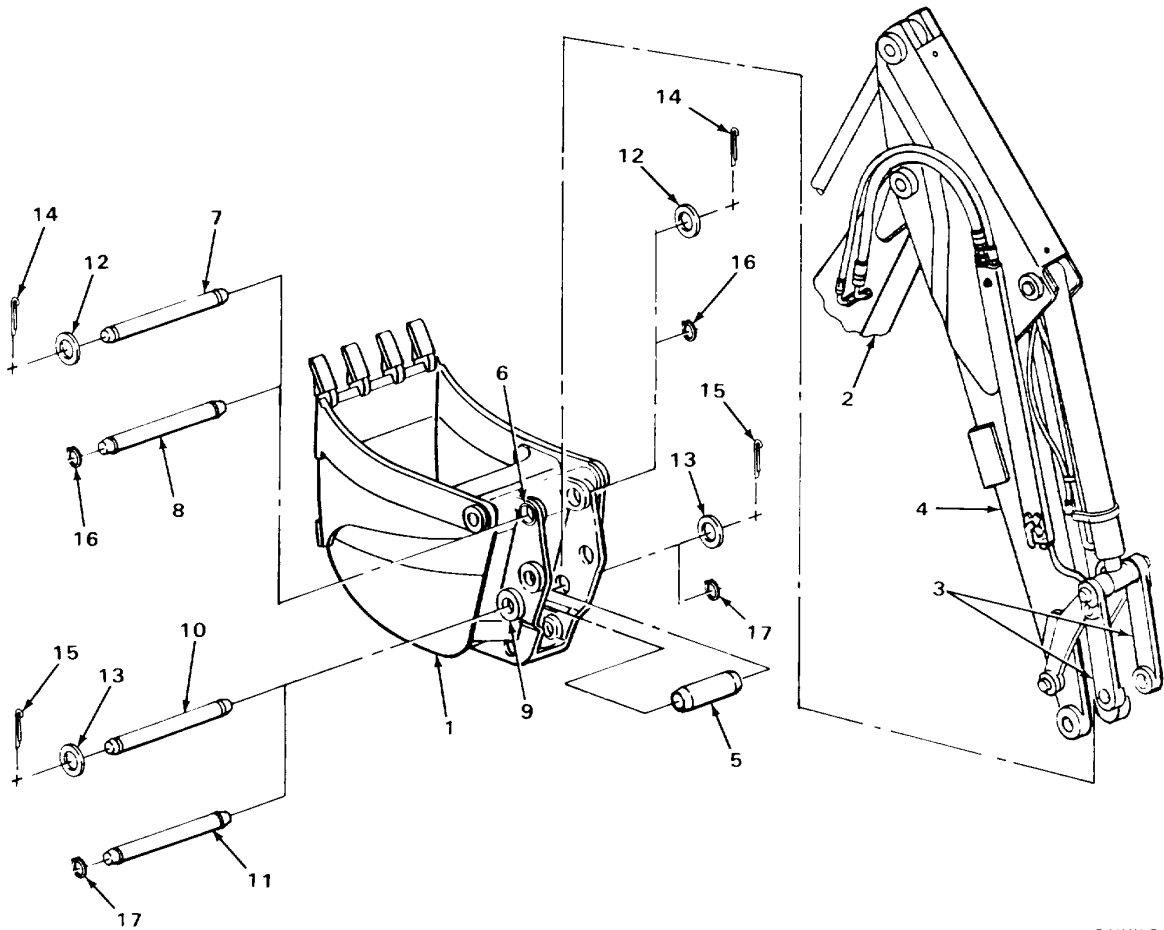

2-XXII-7

TA243602

BACKHOE BUCKET - CONTINUED

LOCATION	ITEM	ACTION	REMARKS
INSTALLATION - CONTINUED			
55.	Two union adapters (1)	Two hoses (2 and 3)	Using 7/8-inch and 1-inch open-end wrenches, tighten.
56.	Loader backhoe	Transmission	Check fluid level and add proper amount and grade (TM 5-2420-222-10). Do not shut down engine at this time.
57.		Backhoe boom control lever	Have assistant operate to pressurize boom cylinder inlet and outlet lines (TM 5-2420-222-10).
58.	Two union adapters (1)	Two hoses (2 and 3)	a. Check for leaks. b. If leaking, tighten using 7/8-inch and 1-inch open-end wrenches. c. If leaking does not stop, shut down engine (TM 5-2420-222-10) and replace leaking parts (TM 5-2420-222-20). d. If leaks were found, repeat step 56.
59.	Loader backhoe	Engine	If running, shut down (TM 5-2420-222-10).

ADJUSTMENT**NOTE**

Power digging position is used for digging in hard ground when maximum bucket power is needed.

Truck loading position is used for loading trucks with high sides. This position allows bucket to retract to its maximum angle. Do not use hydraulic impactor with bucket in this position.

Vertical wall position is used when vertical walls are required while digging. This position allows bucket to open to its maximum angle.

Some loader backhoes have linkage pins retained by cotter pins, some have pins retained by retaining rings. For loader backhoes equipped with retaining rings, skip steps 60 and 61.

BACKHOE BUCKET - CONTINUED

LOCATION	ITEM	ACTION	REMARKS
60. Pin (4) and special washer (5)	Cotter pin (6)	a. Using multiple tongue and groove slip-joint pliers, straighten ends. b. Using 1/4-inch straight drive-pin punch and 2-pound head ball-peen hammer, drive out. c. If not just replaced during installation, get rid of.	
61. Pin (4) and inner bucket (7)	Special washer (5)	Take off.	
62. Pin (8) and inner bucket (7)	Ring (9)	On loader backhoes equipped with retaining rings, using retaining ring pliers, take off.	
63. Guide link (10), two coupler links (11), and backhoe bucket cylinder piston rod (12)	Pin (4 and 8)	Using 3/4-inch brass-tipped driftpin and 2-pound head ball-peen hammer, drive out.	

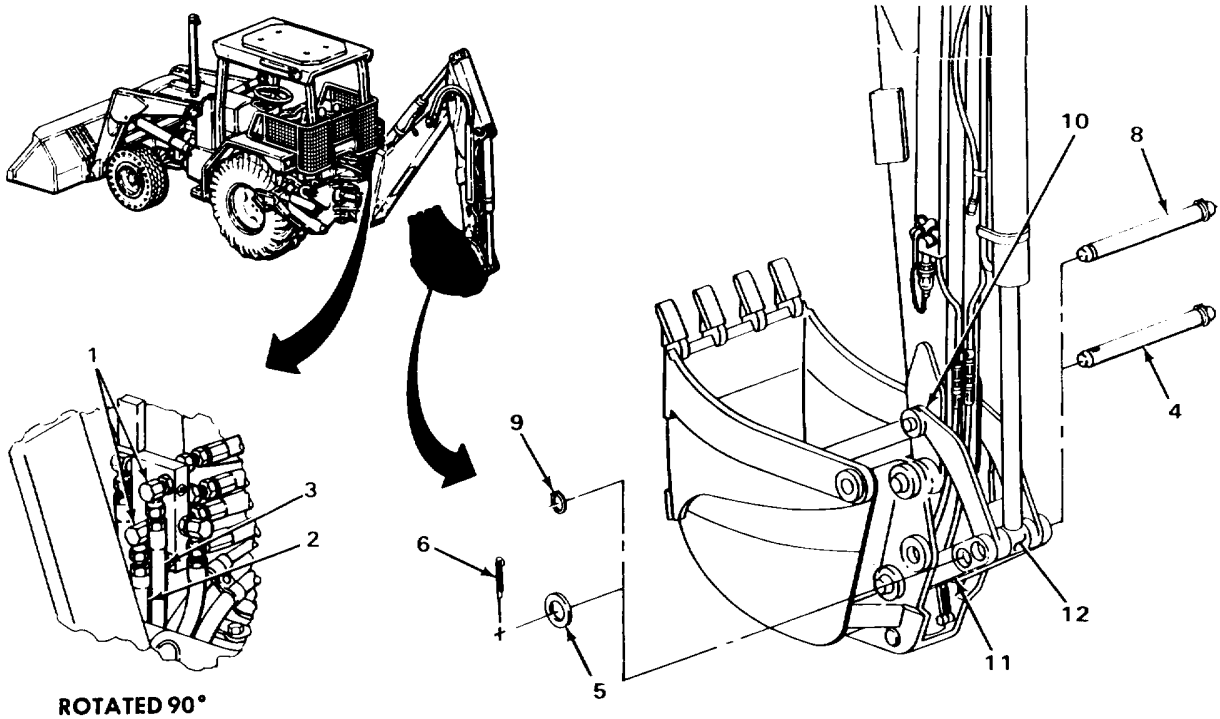

BACKHOE BUCKET - CONTINUED

LOCATION	ITEM	ACTION	REMARKS
64. Two coupler links (1)	Guide link (2) and backhoe bucket cylinder piston rod (3)		With aid of assistant, using backhoe bucket control lever to shorten or lengthen rod (3), position for desired bucket position, aligning pin holes (TM 5-2420-222-10). To position backhoe bucket for power digging and truck loading, guide link and piston rod should be attached to outside hole on coupler links. To position backhoe bucket for vertical wall digging, guide link and piston rod should be attached to inside hole on coupler links.
65. Guide link (2), and coupler links (1), and backhoe bucket cylinder piston rod (3)	Pin (4 or 5)		Using 2-pound head ball-peen hammer, tap in.

NOTE

Some loader backhoes have linkage pins retained by cotter pins, some have pins retained by retaining rings. On loader backhoes equipped with retaining rings, skip steps 66 and 67.

66. Pin (4) and inner bucket (6)	Special washer (7)	Put on.
----------------------------------	--------------------	---------

NOTE

If cotter pin has just been replaced during installation, it may be reused after adjustment. Otherwise, use new cotter pin.

67. Pin (4) and special washer (7)	Cotter pin (8)	a. Push in. b. Using multiple tongue and groove slip-joint pliers, bend ends back.
68. Pin (5) and inner bucket (6)	Ring (9)	On loader backhoes equipped with retaining rings, using retaining ring pliers, put on.

BACKHOE BUCKET - CONTINUED

LOCATION	ITEM	ACTION	REMARKS
----------	------	--------	---------

NOTE

Some loader backhoes have linkage pins retained by cotter pins, some have pins retained by retaining rings. For loader backhoes equipped with retaining rings, skip steps 69 and 70.

- | | | |
|--------------------------------------|---------------------|--|
| 69. Pin (10) and special washer (11) | Cotter pin (12) | <ul style="list-style-type: none"> a. Using multiple tongue and groove slip-joint pliers, straighten ends. b. Using 1/4-inch straight drive-pin punch and 2-pound head ball-peen hammer, tap out. c. If not replaced during installation, get rid of. |
| 70. Pin (10) and inner bucket (6) | Special washer (11) | Take off. |

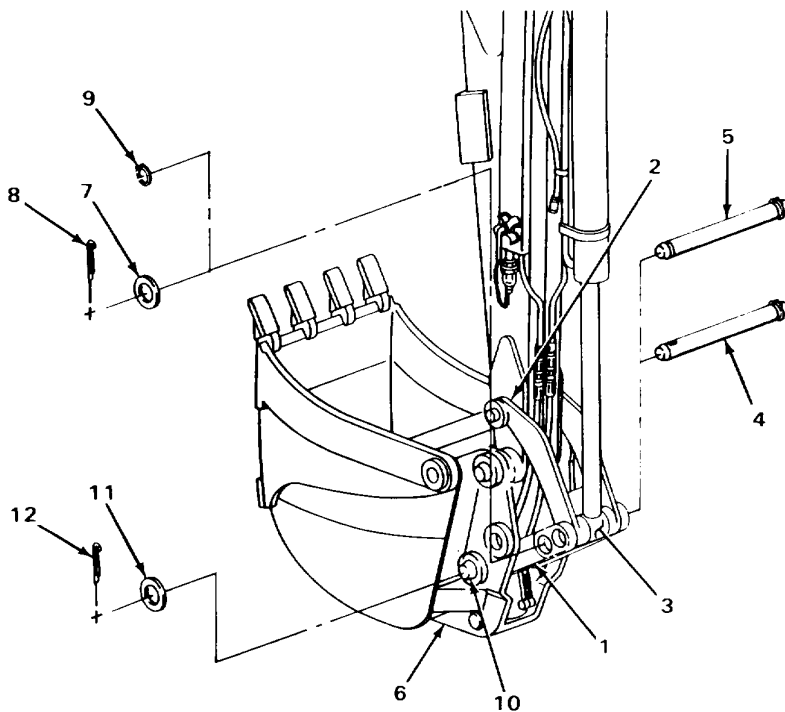

TA243604

BACKHOE BUCKET - CONTINUED

LOCATION	ITEM	ACTION REMARKS
ADJUSTMENT - CONTINUED		
71. Pin (1)	Ring (2)	On loader backhoes equipped with retaining rings, using retaining ring pliers, take off.
72. Two coupler links (3), spacer (4), and inner bucket (5)	Pin (1 or 6)	Using 3/4-inch brass-tipped driftpin and 2-pound head ball-peen hammer, drive out.
73. Two coupler links (3)	Spacer (4)	Take off.
74. Inner bucket (5)	Two coupler links (3)	With aid of assistant, using backhoe bucket control lever to shorten or lengthen backhoe bucket cylinder piston rod (7), position for desired bucket position aligning pin holes (TM 5-2420-222-10). To position bucket for vertical wall or power digging, attach to bottom hole on inner bucket. To position bucket for truck loading, attach to middle hole on inner bucket.
75. Two coupler links (3)	Spacer (4)	Place in position.
76. Two coupler links (3), spacer (4), and inner bucket (5)	Pin (1 or 6)	Using 2-pound head ball-peen hammer, tap in.
NOTE		
Some loader backhoes have linkage pins retained by cotter pins, some have pins retained by retaining rings. For loader backhoes equipped with retaining rings, skip steps 77 and 78.		
77. Pin (6) and inner bucket (5)	Special washer (8)	Put on.
NOTE		
If cotter pin has just been replaced during installation, it may be reused after adjustment. Otherwise, use new cotter pin.		
78. Pin (6) and special washer (8)	Cotter pin (9)	a. Push in. b. Using multiple tongue and groove slip-joint pliers, bend ends back.

BACKHOE BUCKET - CONTINUED

LOCATION	ITEM	ACTION	REMARKS
----------	------	--------	---------

79. Pin (1) and inner bucket (5)

Ring (2)

On loader backhoes equipped with retaining rings, using retaining ring pliers, put on.

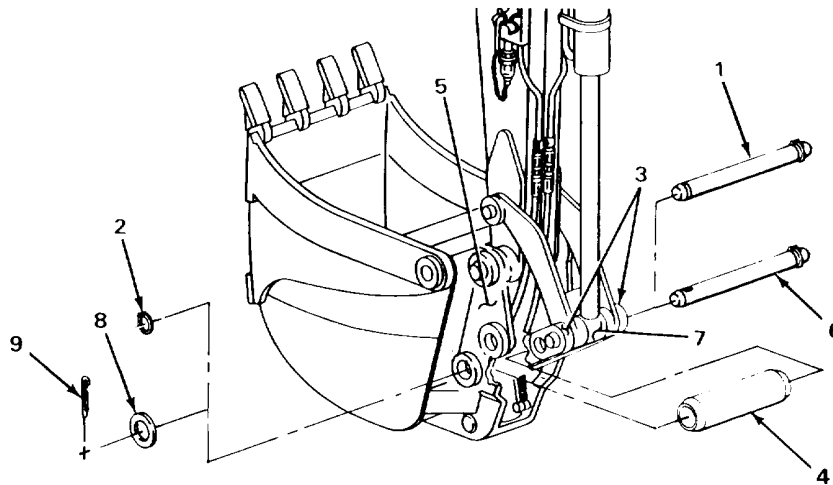

TASK ENDS HERE

BACKHOE BUCKET TEETH

This task covers:

- a. Removal (page 2-1816)
- b. Cleaning (page 2-1816)
- c. Inspection/Replacement (page 2-1816)
- d. Installation (page 2-1817)

INITIAL SETUP

Tools

- Block, wood
- Driftpin, brass-tipped, 3/4-inch
- Hammer, cross-peen, 3-pound head
- Punch, drive-pin, straight, 1/4-inch

Materials/Parts

- Detergent, GP (item 7, Appendix C)

Materials/Parts - Continued

- Rags, wiping (item 21, Appendix C)
- Solvent, drycleaning (item 28, Appendix C)

Personnel Required

One

TA243605

BACKHOE BUCKET TEETH - CONTINUED

LOCATION	ITEM	ACTION	REMARKS
REMOVAL			
1.	Four backhoe bucket shanks (1) and teeth (2)	Four pins (3)	Using 3-pound head cross-peen hammer and 1/4-inch straight drive-pin punch, drive out.
2.	Four backhoe bucket shanks (1)	Four teeth (2)	Using 3-pound head cross-peen hammer and 3/4-inch brass-tipped driftpin, drive off.

CLEANING

NOTE

For more information on how to clean parts, go to **General Maintenance Instructions (page 2-137)**.

- | | | |
|----|---------------|---|
| 3. | Four pins (3) | a. Clean in solution of detergent and water.
b. Rinse in clean water.
c. Using clean, dry rags, wipe dry. |
|----|---------------|---|

WARNING

Drycleaning solvent P-D-680 is toxic and flammable. Wear protective goggles and gloves and use only in a well ventilated area. Avoid contact with skin, eyes, and clothes and don't breathe vapors. Do not use near open flame or excessive heat. The flashpoint is 100°F to 138°F (38° to 59°C). If you become dizzy while using cleaning solvent, get fresh air immediately and get medical aid. If contact with eyes is made, wash your eyes with water and get medical aid immediately.

- | | | |
|----|----------------|---|
| 4. | Four teeth (2) | a. Clean in drycleaning solvent.
b. Using clean, dry rags, wipe dry. |
|----|----------------|---|

INSPECTION/REPLACEMENT

NOTE

For more information on how to inspect parts, go to **General Maintenance Instructions (page 2-137)**.

Replace defective parts as needed.

- | | | |
|----|---------------|--|
| 5. | Four pins (3) | Look for cracks, breaks, bends, crumbling, and separation. |
|----|---------------|--|

BACKHOE BUCKET TEETH - CONTINUED

LOCATION	ITEM	ACTION REMARKS
6.	Four teeth (2)	Look for cracks, breaks, and abnormal bends.
INSTALLATION		
7. Four backhoe bucket shanks (1)	Four teeth (2)	Using 3-pound head cross-peen hammer and wood block, drive on until pin holes line up.
8. Four backhoe bucket shanks (1) and teeth (2)	Four pins (3)	Using 3-pound head cross-peen hammer and 1/4-inch straight drive-pin punch, drive in.

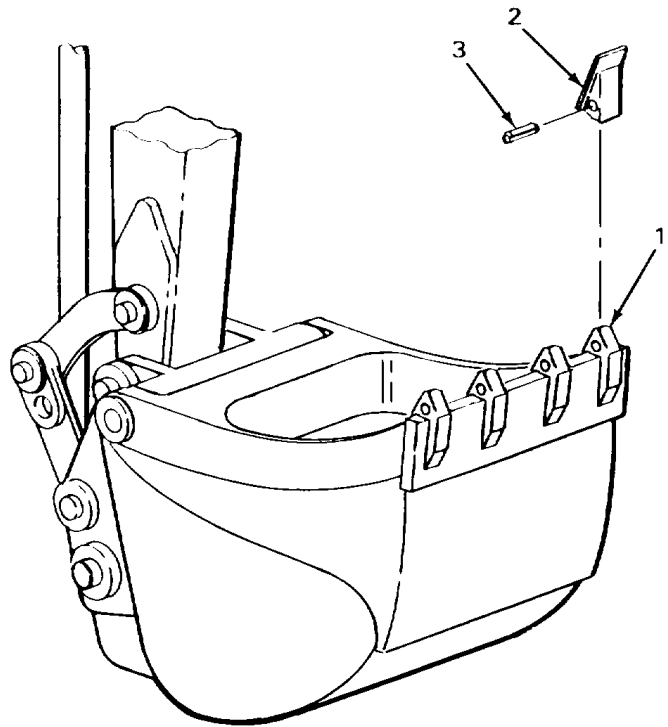
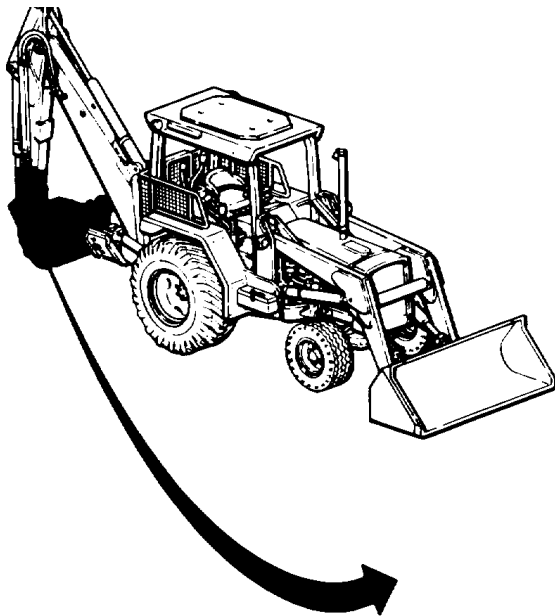

TASK ENDS HERE

TA243606

BACKHOE BUCKET LINKAGE

This task covers:

- a. Removal (page 2-1818)
 - b. Cleaning (page 2-1818)
 - c. Inspection/Replacement (page 2-1822)
 - d. Installation (page 2-1822)
-

INITIAL SETUP

Tools

Driftpin, brass-tipped, 3/4-inch
 Hammer, cross-peen, 3-pound head

NOTE

The following tool only applies to loader backhoes with linkage pins retained by retaining rings.

Pliers, retaining ring

NOTE

The following tools only apply to loader backhoes with linkage pins retained by cotter pins.

Pliers, slip-joint, multiple tongue and groove
 Punch, drive-pin, straight, 1/4-inch

Materials/Parts

Rags, wiping (item 21, Appendix C)
 Solvent, drycleaning (item 28, Appendix C)

NOTE

The following parts only apply to loader backhoes with linkage pins retained by cotter pins.

Pin, cotter, dipperstick pin (two required)
 Pin, cotter, guide link pin (two required)
 Pin, cotter, coupler link pin (two required)

Personnel Required

Two

LOCATION	ITEM	ACTION	REMARKS
----------	------	--------	---------

REMOVAL

NOTE

Some loader backhoes have linkage pins retained by retaining rings, some have pins retained by cotter pins. For loader backhoes that are equipped with retaining rings, skip steps 1 and 2.

- | | | |
|--|---------------------|--|
| 1. Pin (1) and two special washers (2) | Two cotter pins (3) | a. Using multiple tongue and groove slip-joint pliers, straighten ends.
b. Using 3-pound head cross-peen hammer and 1/4-inch straight drive-pin punch, drive out.
c. Get rid of. |
|--|---------------------|--|

BACKHOE BUCKET LINKAGE - CONTINUED

LOCATION	ITEM	ACTION	REMARKS
2. Pin (1) and two coupler links (4)	Two special washers (2)	Take off.	
3. Pin (5) and two coupler links (4)	Two rings (6)	On loader backhoes equipped with retaining rings, using retaining ring pliers, take off.	
4. Backhoe bucket cylinder piston rod (7), guide link (8), and two coupler links (4)	Pin (1 or 5)	Using 3-pound head cross-peen hammer and 3/4-inch brass-tipped driftpin, drive out.	
5. Backhoe bucket cylinder piston rod (7)	Guide link (8) and two coupler links (4)	Pivot apart.	

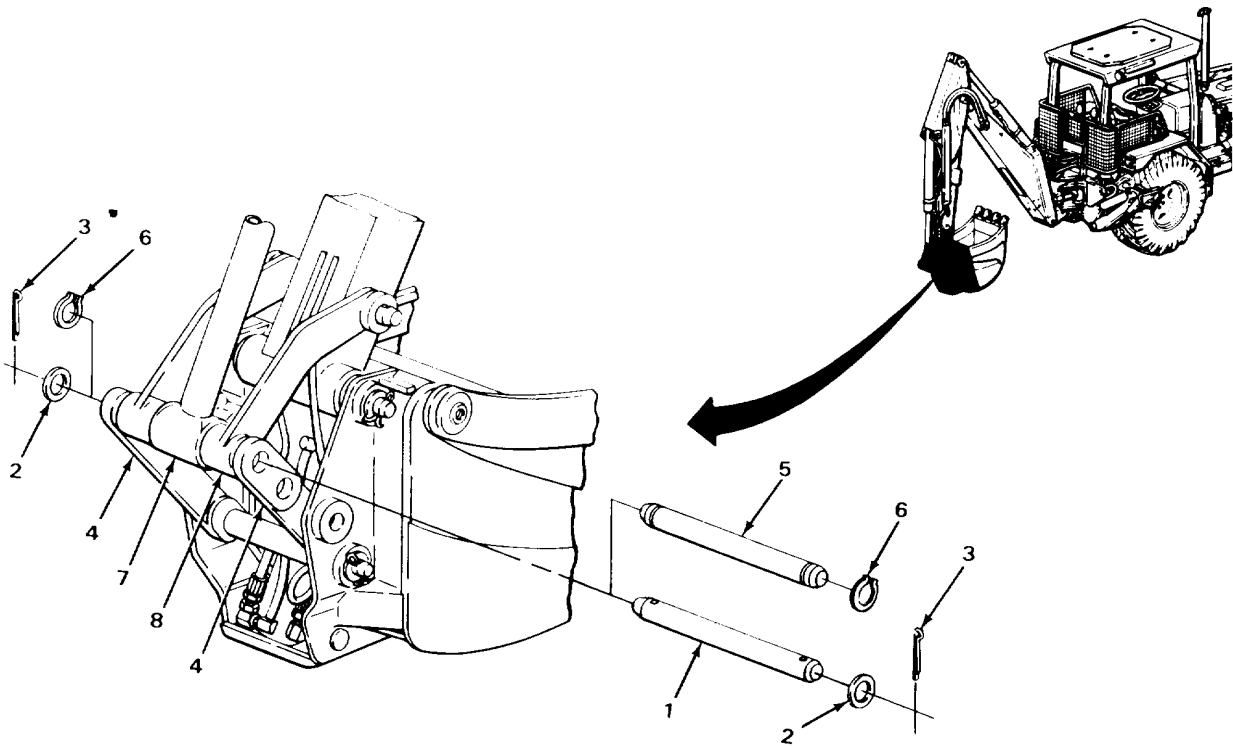

TA243607

BACKHOE BUCKET LINKAGE - CONTINUED

LOCATION	ITEM	ACTION	REMARKS
----------	------	--------	---------

REMOVAL - CONTINUED

NOTE

Some loader backhoes have linkage pins retained by cotter pins, some have pins retained by retaining rings. For loader backhoes that are equipped with retaining rings, skip steps 6 and 7.

6.	Pin (1) and two special washers (2)	Two cotter pins (3)	<ol style="list-style-type: none"> Using multiple tongue and groove slip-joint pliers, straighten ends. Using 1/4-inch straight-drive pin punch and 3-pound head cross-peen hammer, drive out. Get rid of.
7.	Pin (1) and guide link (4)	Two special washers (2)	Take off.
8.	Pins (5) and guide link (4)	Two rings (6)	On loader backhoes equipped with retaining rings, using retaining ring pliers, take off.
9.	Dipperstick (7)	Pin (1 or 5)	With aid of assistant, using 3-pound head cross-peen hammer and 3/4-inch brass-tipped driftpin, drive out.
10.		Guide link (4)	Take off.

NOTE

Some loader backhoes have linkage pins retained by cotter pins, some have pins retained by retaining rings. For loader backhoes that are equipped with retaining rings, skip steps 11 and 12.

11.	Pin (8) and two special washers (9)	Two cotter pins (10)	<ol style="list-style-type: none"> Using multiple tongue and groove slip-joint pliers, straighten ends. Using 1/4-inch straight-drive pin punch and 3-pound head cross-peen hammer, drive out. Get rid of.
12.	Pin (8) and inner bucket (11)	Two special washers (9)	Take off.

BACKHOE BUCKET LINKAGE - CONTINUED

LOCATION	ITEM	ACTION	REMARKS
13. Pin (12) and inner bucket (11)	Two rings (13)	On loader backhoes equipped with retaining rings, using retaining ring pliers, take off.	
14. Inner bucket (11), two coupler links (14), and spacer (15)	Pin (8 or 12)	With aid of assistant, using 3/4-inch brass-tipped driftpin and 3-pound head cross-peen hammer, drive out.	
15. Inner bucket (11)	Spacer (15) and two coupler links (14)	Take off.	

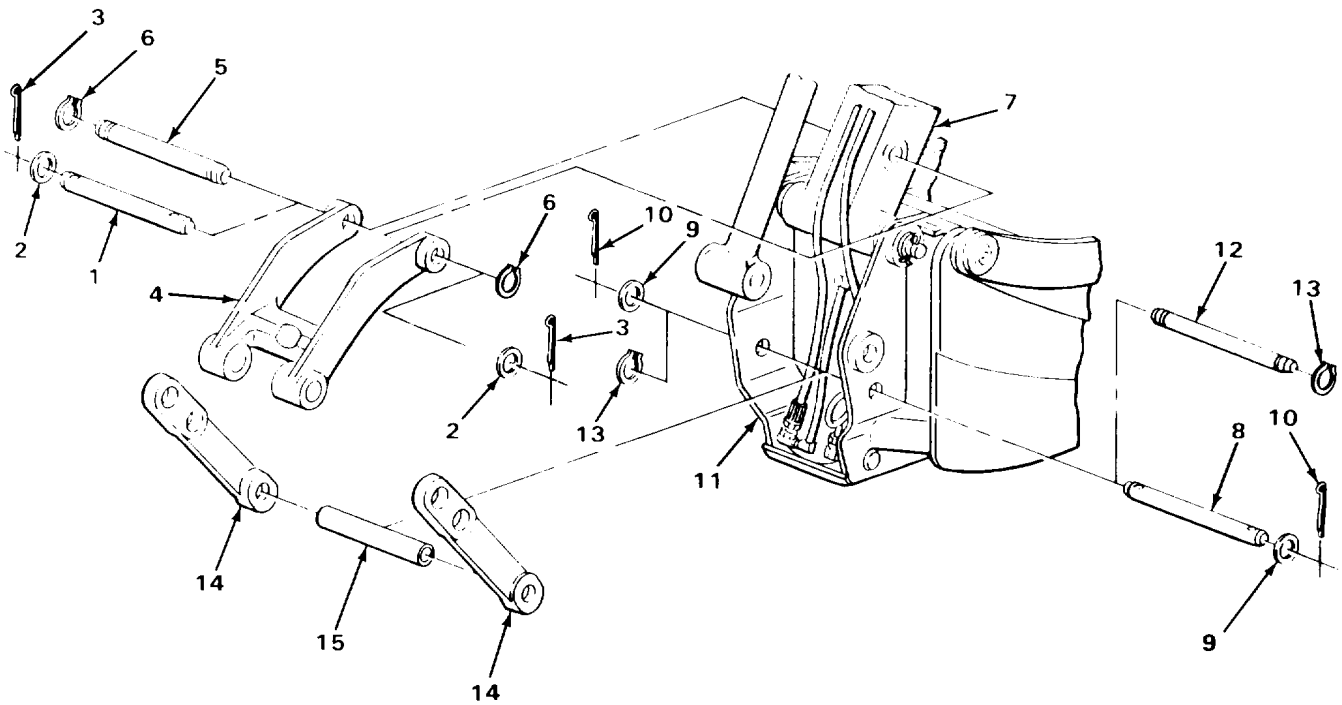

TA243608

BACKHOE BUCKET LINKAGE - CONTINUED

LOCATION	ITEM	ACTION	REMARKS
----------	------	--------	---------

CLEANING

NOTE

For more information on how to clean parts, go to General Maintenance Instructions (page 2-137).

WARNING

Drycleaning solvent P-D-680 is toxic and flammable. Wear protective goggles and gloves and use only in a well ventilated area. Avoid contact with skin, eyes, and clothes and don't breathe vapors. Do not use near open flame or excessive heat. The flashpoint is 100°F to 138°F (38° to 59°C). If you become dizzy while using cleaning solvent, get fresh air immediately and get medical aid. If contact with eyes is made, wash your eyes with water and get medical aid immediately.

- | | | | |
|-----|-----------------|----------------------------------|-------------------------------------|
| 16. | All metal parts | a. Clean in drycleaning solvent. | b. Using clean, dry rags, wipe dry. |
|-----|-----------------|----------------------------------|-------------------------------------|

INSPECTION/REPLACEMENT

NOTE

For more information on how to inspect parts, go to General Maintenance Instructions (page 2-137).

Replace defective parts as needed.

- | | | | |
|-----|-----------------|--|--|
| 17. | All metal parts | Look for cracks, breaks, and abnormal bends. | |
|-----|-----------------|--|--|

INSTALLATION

- | | | | |
|---|--------------------------------------|---|--|
| 18. Inner bucket (1) | Two coupler links (2) and spacer (3) | Have assistant place in position and align pin holes. | |
| 19. Inner bucket (1), two coupler links (2), and spacer (3) | Pin (4 or 5) | Using 3-pound head cross-peen hammer, tap in. | |

NOTE

Some loader backhoes have linkage pins that are retained by cotter pins, some have pins that are retained by retaining rings. For loader backhoes that are equipped with retaining rings, skip steps 20 and 21.

BACKHOE BUCKET LINKAGE - CONTINUED

LOCATION	ITEM	ACTION	REMARKS
20. Pin (4) and inner bucket (1)	Two special washers (6)	Put on.	
21. Pin (4) and two special washers (6)	Two new cotter pins (7)	a. Push in. b. Using multiple tongue and groove slip-pliers, bend ends back.	

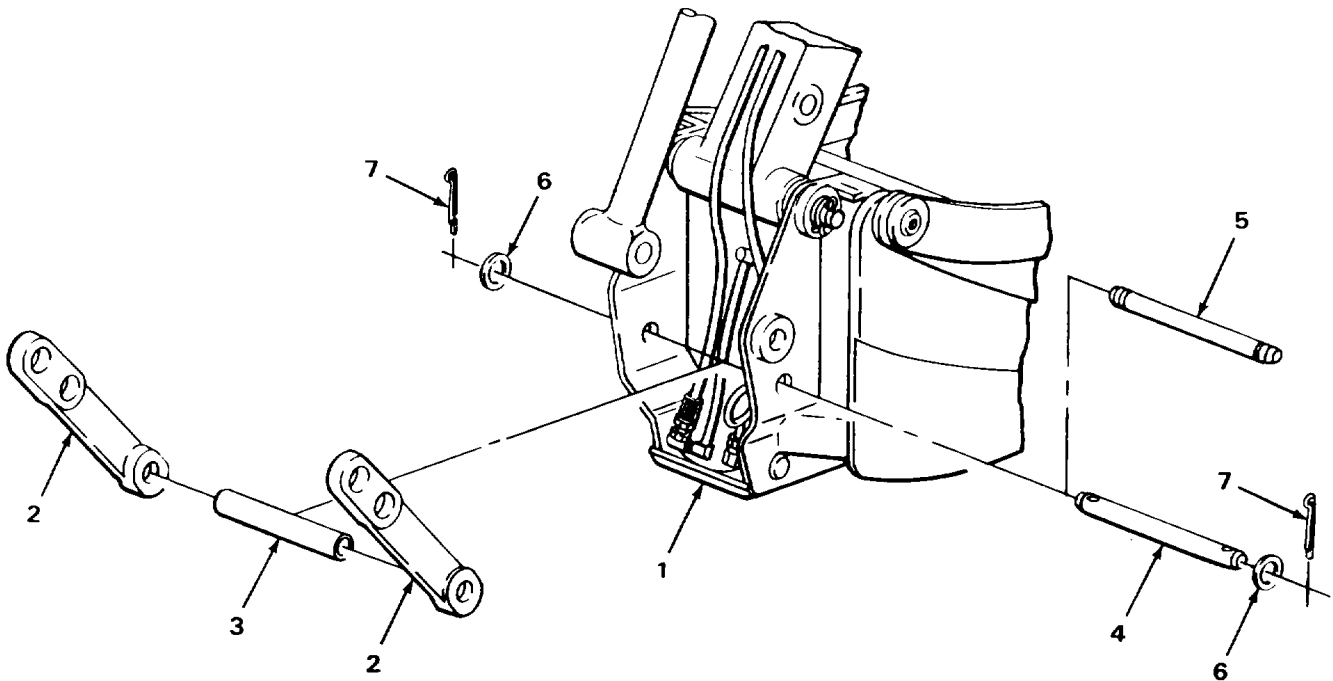

TA243609

BACKHOE BUCKET LINKAGE - CONTINUED

LOCATION	ITEM	ACTION	REMARKS
INSTALLATION - CONTINUED			
22.	Pin (1) and inner bucket (2)	Two rings (3)	On loader backhoes equipped with retaining rings, using retaining ring pliers, put on.
23.	Dipperstick (4)	Guide link (5)	Have assistant place in position and align pin holes.
24.	Dipperstick (4) and guide link (5)	Pin (6 or 7)	Using 3-pound head cross-peen hammer, tap in.

NOTE

Some loader backhoes have linkage pins that are retained by cotter pins, some have pins that are retained by retaining rings. For loader backhoes that are equipped with retaining rings, skip steps 25 and 26.

25.	Pin (6) and guide link (5)	Two special washers (8)	Put on.
26.	Pin (6) and two special washers (8)	Two new cotter pins (9)	a. Push in. b. using multiple tongue and groove slip-joint pliers, bend ends back.
27.	Pin (7) and guide link (5)	Two rings (10)	On loader backhoes equipped with retaining rings, using retaining ring pliers, put on.
28.	Backhoe bucket cylinder piston rod (11)	Guide link (5) and two coupler links (12)	Have assistant pivot into position and align pin holes.
29.	Backhoe bucket cylinder piston rod (11), guide link (5), and two coupler links (12)	Pin (13 or 14)	Using 3-pound head cross-peen hammer, tap in.

NOTE

Some loader backhoes have linkage pins that are retained by cotter pins, some have pins that are retained by retaining rings. For loader backhoes that are equipped with retaining rings, skip steps 30 and 31.

BACKHOE BUCKET LINKAGE - CONTINUED

LOCATION	ITEM	ACTION REMARKS
30. Pin (13) and two coupler links (12)	Two special washers (15)	Put on.
31. Pin (13) and two special washers (15)	Two new cotter pins (16)	a. Push in. b. Using multiple tongue and groove slip-joint pliers, bend ends back.

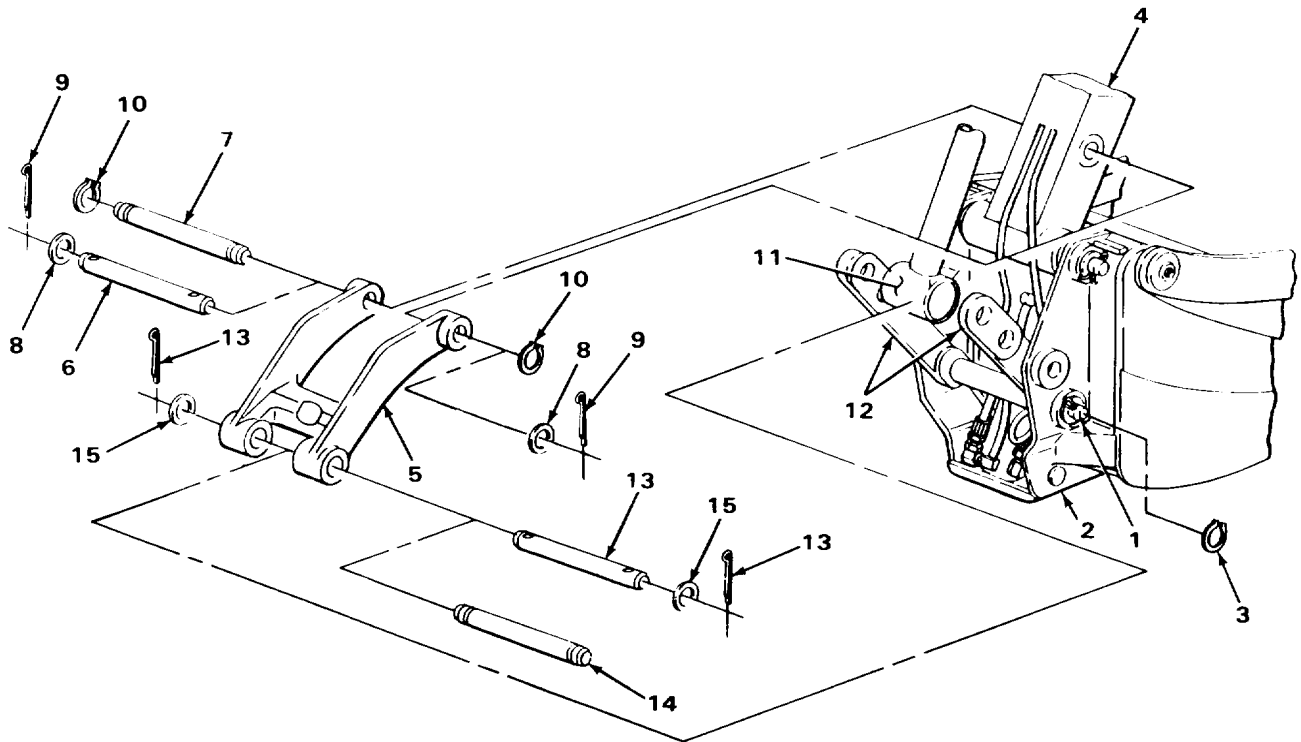

TA243610

BACKHOE BUCKET LINKAGE - CONTINUED

LOCATION	ITEM	ACTION	REMARKS
----------	------	--------	---------

INSTALLATION - CONTINUED

- | | | |
|---------------------------------------|---------------|--|
| 32. Pin (1) and two coupler links (2) | Two rings (3) | On loader backhoes equipped with retaining rings, using retaining ring pliers, put on. |
|---------------------------------------|---------------|--|

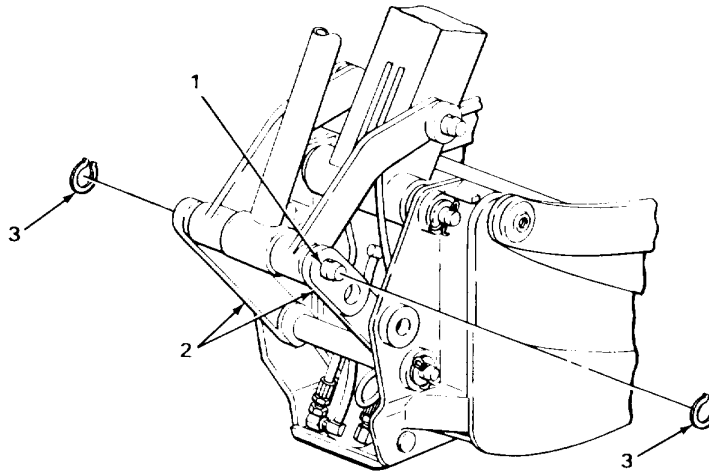

TASK ENDS HERE

BACKHOE DIPPERSTICK HOSE GUARDS (SERIAL NUMBERS 319995 THRU 342573 ONLY)

This task covers:

- | | |
|---|---|
| <ul style="list-style-type: none"> a. Removal (page 2-1827) b. Disassembly (page 2-1828) c. Cleaning (page 2-1828) | <ul style="list-style-type: none"> d. Inspection/Replacement (page 2-1828) e. Assembly (page 2-1829) f. Installation (page 2-1829) |
|---|---|

INITIAL SETUP

Tools

- Handle, ratchet, 3/8-inch drive
- Socket, 3/8-inch drive, 9/16-inch

Materials/Parts

- Detergent, GP (item 7, Appendix C)
- Lockwasher, guard screw (two required)

Materials/Parts - Continued

- Rags, wiping (item 21, Appendix C)
- Solvent, drycleaning (item 28, Appendix C)

Personnel Required

One

TA243611

BACKHOE DIPPERSTICK HOSE GUARDS (SERIAL NUMBERS 319995 THRU 342573 ONLY) - CONTINUED

LOCATION	ITEM	ACTION	REMARKS
----------	------	--------	---------

NOTE

Both backhoe dipperstick hose guards are maintained the same way except as noted. Right hose guard is shown. Repeat procedures as needed for left hose guard.

REMOVAL

- | | | |
|---|--|---|
| 1. Guard (1), two clamps (2), and dipperstick (3) | Two screws (4), washers (5), and lockwashers (6) | <ul style="list-style-type: none"> a. Using 9/16-inch, 3/8-inch drive socket and ratchet handle, unscrew and take out. b. Get rid of lockwashers (6). |
| 2. Two clamps (2) and dipperstick (3) | Guard (1) | Take off. |
| 3. Two tubes (7 and 8) and dipperstick (3) | Two clamps (2) | Take off. |

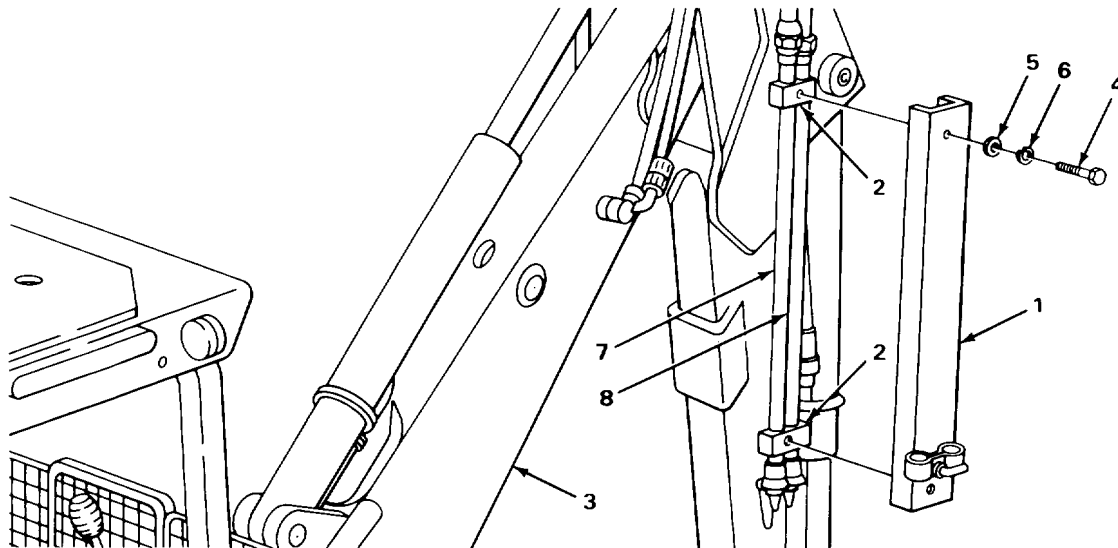

TA243612

BACKHOE DIPPERSTICK HOSE GUARDS (SERIAL NUMBERS 319995 THRU 342573 ONLY) - CONTINUED

LOCATION	ITEM	ACTION	REMARKS
----------	------	--------	---------

DISASSEMBLY

NOTE

Right side has two clamps and clamp screw for mounting accessory hoses. Left side does not have these parts. If maintaining left backhoe dipperstick hose guard, skip steps 4 and 5.

- | | | | |
|----|------------------------------|-----------------|-----------------------|
| 4. | Two clamps (1) and guard (2) | Clamp screw (3) | Unscrew and take out. |
| 5. | Guard (2) | Two clamps (1) | Take off. |

CLEANING

NOTE

For more information on how to clean parts, go to General Maintenance Instructions (page 2-137).

- | | | |
|----|----------------|---|
| 6. | Two clamps (4) | a. Using clean rags dampened in solution of detergent and water, wipe clean.
b. Rinse with clean water.
c. Using clean, dry rags, wipe dry. |
|----|----------------|---|

WARNING

Drycleaning solvent P-D-680 is toxic and flammable. Wear protective goggles and gloves and use only in a well ventilated area. Avoid contact with skin, eyes, and clothes and don't breathe vapors. Do not use near open flame or excessive heat. The flashpoint is 100°F to 138°F (38° to 59°C). If you become dizzy while using cleaning solvent, get fresh air immediately and get medical aid. If contact with eyes is made, wash your eyes with water and get medical aid immediately.

- | | | |
|----|-----------------|---|
| 7. | All metal parts | a. Clean in drycleaning solvent.
b. Using clean, dry rags, wipe dry. |
|----|-----------------|---|

INSPECTION/REPLACEMENT

NOTE

For more information on how to inspect parts, go to General Maintenance Instructions (page 2-137).

Replace defective parts as needed.

BACKHOE DIPPERSTICK HOSE GUARDS (SERIAL NUMBERS 319995 THRU 342573 ONLY) - CONTINUED

LOCATION	ITEM	ACTION	REMARKS
8.	Two clamps (4)		Look for cracks, breaks, and crumbling.
9.	All metal parts		Look for cracks, breaks, and abnormal bends.
10.	All threaded parts		Look for damaged threads.

ASSEMBLY

NOTE

If maintaining left backhoe dipperstick hose guard, skip steps 11 and 12.

11.	Guard (2)	Two clamps (1)	Place in position.
12.	Guard (2) and two clamps (1)	Clamp screw (3)	Screw in and tighten until snug.

INSTALLATION

13.	Two tubes (5 and 6) and dipperstick (7)	Two clamps (4)	Place in position.
-----	---	----------------	--------------------

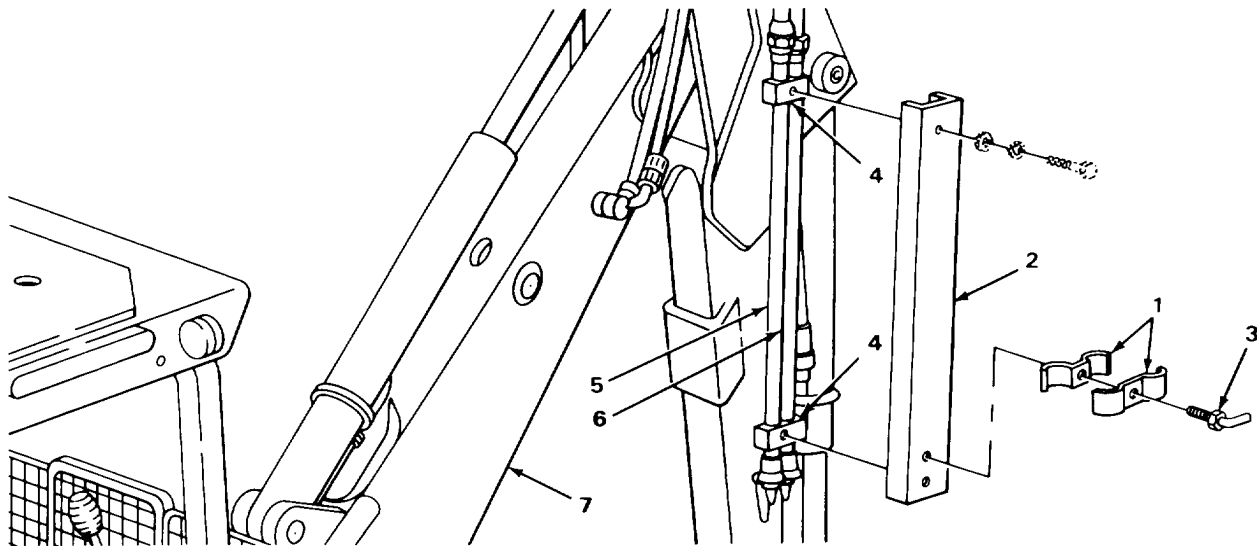

TA243613

BACKHOE DIPPERSTICK HOSE GUARDS (SERIAL NUMBERS 319995 THRU 342573 ONLY) - CONTINUED

LOCATION	ITEM	ACTION	REMARKS
INSTALLATION - CONTINUED			
14. Two clamps (1) and dipperstick (2)	Guard (3)	Place in position.	
15. Guard (3), two clamps (1), and dipperstick (2)	Two screws (4), washers (5), and new lockwashers (6)	Screw in and tighten using 9/16-inch, 3/8-inch drive socket and ratchet handle.	

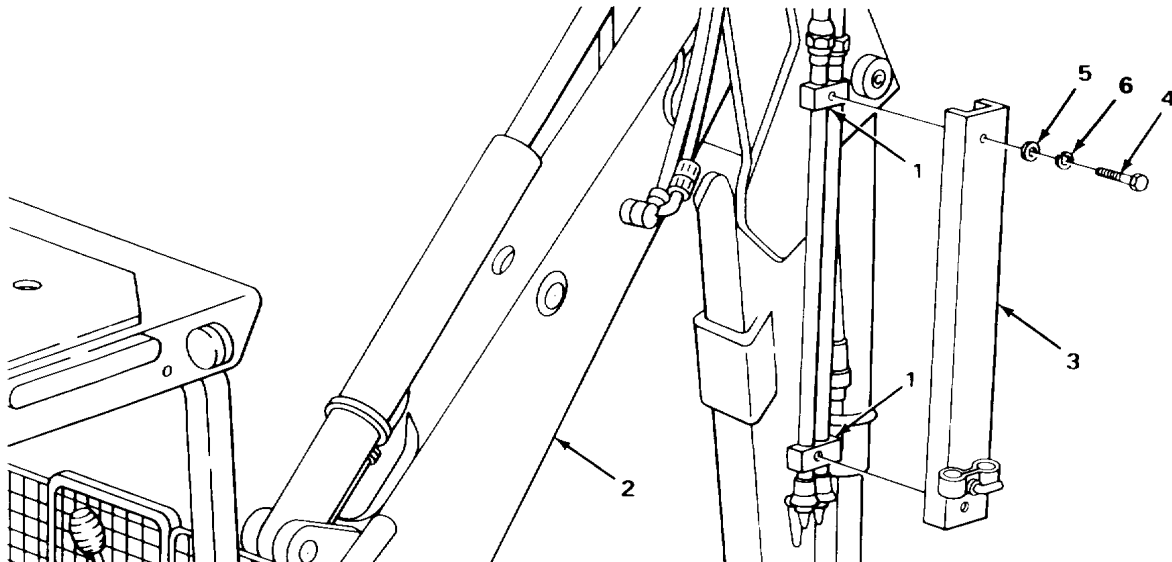

TASK ENDS HERE

LOADER BUCKET SUPPORT

This task covers:

- a. Installation (page 2-1831)
- b. Removal (page 2-1832)

INITIAL SETUP

Tools

Support, bucket (Appendix D)

Personnel Required

One

TA243614

LOADER BUCKET SUPPORT - CONTINUED

LOCATION	ITEM	ACTION	REMARKS
INSTALLATION			
1. Loader backhoe	Engine	Start (TM 5-2420-222-10).	
2.	Loader bucket	Raise (TM 5-2420-222-10).	

WARNING

Keep clear of hydraulic components when raised and not supported. Sudden loss of hydraulic pressure could cause components to drop without warning.

CAUTION

Make sure loader bucket support is resting on loader boom cylinder head and not on loader boom cylinder guide rod and spanner nut or these parts may be damaged. Be careful when placing bucket support in position or loader boom cylinder piston rod may be damaged. Parts damaged may cause failure of loader boom cylinder.

- | | | |
|-----------------|---|--|
| 3. Lift arm (1) | Loader boom cylinder head (2) and loader boom cylinder piston rod (3) | <ul style="list-style-type: none"> a. Pull out bucket support knob. b. Place bucket support in position. c. Release bucket support knob to secure in place. |
|-----------------|---|--|

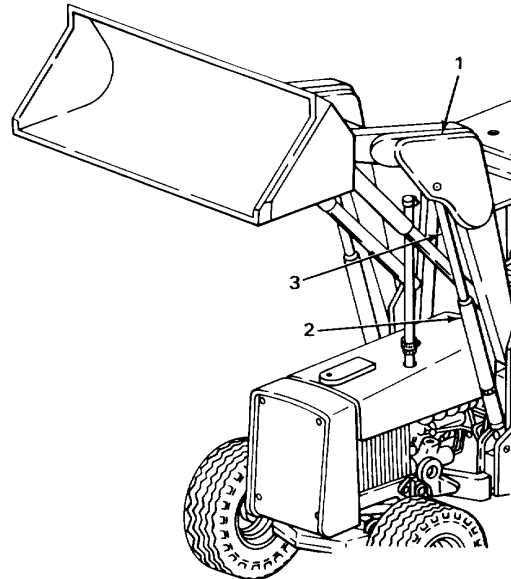
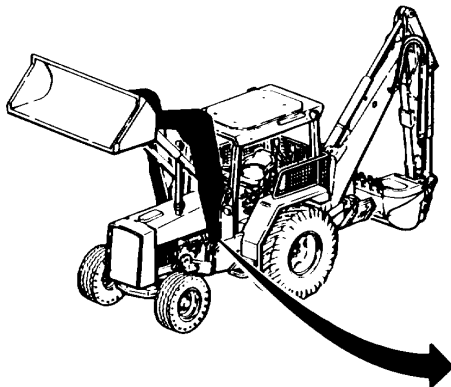

TA243615

BACKHOE DIPPERSTICK HOSE GUARDS (SERIAL NUMBERS 319995 THRU 342573 ONLY) - CONTINUED

LOCATION	ITEM	ACTION	REMARKS
INSTALLATION - CONTINUED			
4. Loader backhoe	Loader bucket	Lower (TM 5-2420-222-10) until lift arm (1) is resting on bucket support.	
5.	Engine	Shut down (TM 5-2420-222-10).	
REMOVAL			
6. Loader backhoe	Engine	Start (TM 5-2420-222-10).	
7.	Loader bucket	Raise (TM 5-2420-222-10) off bucket support.	
<u>WARNING</u>			
Keep clear of hydraulic components when raised and not supported. Sudden loss of hydraulic pressure could cause components to drop without warning.			
<u>CAUTION</u>			
Be careful when removing bucket support or loader boom cylinder piston rod may be damaged. Damage to part may cause failure of loader boom cylinder.			
8. Lift arm (1)	Loader boom cylinder head (2) and loader boom cylinder piston rod (3)	a. Pull out bucket support knob. b. Take bucket support off. c. Release bucket support knob.	
9. Loader backhoe	Loader bucket	Lower (TM 5-2420-222-10).	
10.	Engine	Shut down (TM 5-2420-222-10).	

LOADER BUCKET SUPPORT - CONTINUED

LOCATION	ITEM	ACTION	REMARKS
----------	------	--------	---------

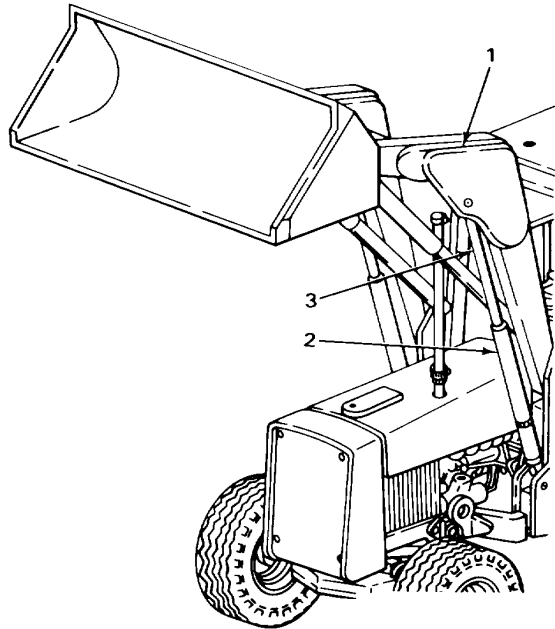
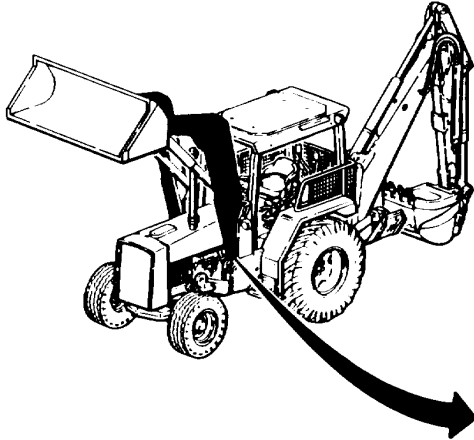

TASK ENDS HERE

LOADER BUCKET

This task covers:

- a. Removal (page 2-1834)
- b. Cleaning (page 2-1834)
- c. Inspection/Replacement (page 2-1836)
- d. Repair (page 2-1836)
- e. Installation (page 2-1836)

INITIAL SETUP

Tools

- Blocks, wood
- Driftpin, brass-tipped, 3/4-inch
- Extension, 1/4-inch drive, 2-inch
- Hammer, cross-peen, 3-pound head
- Handle, ratchet, 1/4-inch drive
- Pliers, retaining ring
- Socket, 1/4-inch drive, 7/16-inch

Materials/Parts

- Rags, wiping (item 21, Appendix C)
- Ring, retaining (eight required)
- Solvent, drycleaning (item 28, Appendix C)

Personnel Required

Two

LOADER BUCKET SUPPORT - CONTINUED

LOCATION	ITEM	ACTION	REMARKS
REMOVAL			
<u>WARNING</u>			
Keep clear of hydraulic components when raised and not supported. Sudden loss of hydraulic pressure could cause components to drop without warning.			
1. Loader backhoe	Loader bucket (1)	a. Have assistant raise (TM 5-2420-222-10). b. Place wood blocks underneath. c. Have assistant lower onto wood blocks (TM 52420-222-10).	
2. Two pins (2)	Two grease fittings (3)		Using 7/16-inch, 1/4-inch drive socket, 2-inch extension, and ratchet handle, unscrew and take out.
3. Four pins (2 and 4)	Eight rings (5 and 6)	a. Using retaining ring pliers, take off. b. Get rid of.	
4. Loader bucket (1)	Lift arms		Have assistant raise just enough to take pressure off pins (1 and 3) (TM 5-2420-222-10).
5. Loader bucket (1) and lift arm (7)	Two pins (2)		Using 3-pound head cross-peen hammer and 3/4-inch brass-tipped driftpin placed on end without grease fitting hole, drive out.
6. Loader bucket (1) and bucket link (8)	Two pins (4)		Using 3-pound head cross-peen hammer and 3/4-inch brass-tipped driftpin, drive out.
7. Loader bucket (1)	Loader backhoe		Have assistant back away from (TM 5-2420-222-10).

CLEANING

NOTE

For more information on how to clean parts, go to **General Maintenance Instructions (page 2-137)**.

LOADER BUCKET - CONTINUED

LOCATION	ITEM	ACTION	REMARKS
----------	------	--------	---------

WARNING

Drycleaning solvent P-D-680 is toxic and flammable. Wear protective goggles and gloves and use only in a well ventilated area. Avoid contact with skin, eyes, and clothes and don't breathe vapors. Do not use near open flame or excessive heat. The flashpoint is 100°F to 138°F (38° to 59°C). If you become dizzy while using cleaning solvent, get fresh air immediately and get medical aid. If contact with eyes is made, wash your eyes with water and get medical aid immediately.

- | | | |
|----|-----------------------|--|
| 8. | Loader bucket (1) | <ul style="list-style-type: none"> a. Using clean, dry rags dampened in drycleaning solvent, wipe clean. b. Using clean, dry rags, wipe dry. |
| 9. | All other metal parts | <ul style="list-style-type: none"> a. Clean in drycleaning solvent. b. Using clean, dry rags, wipe dry. |

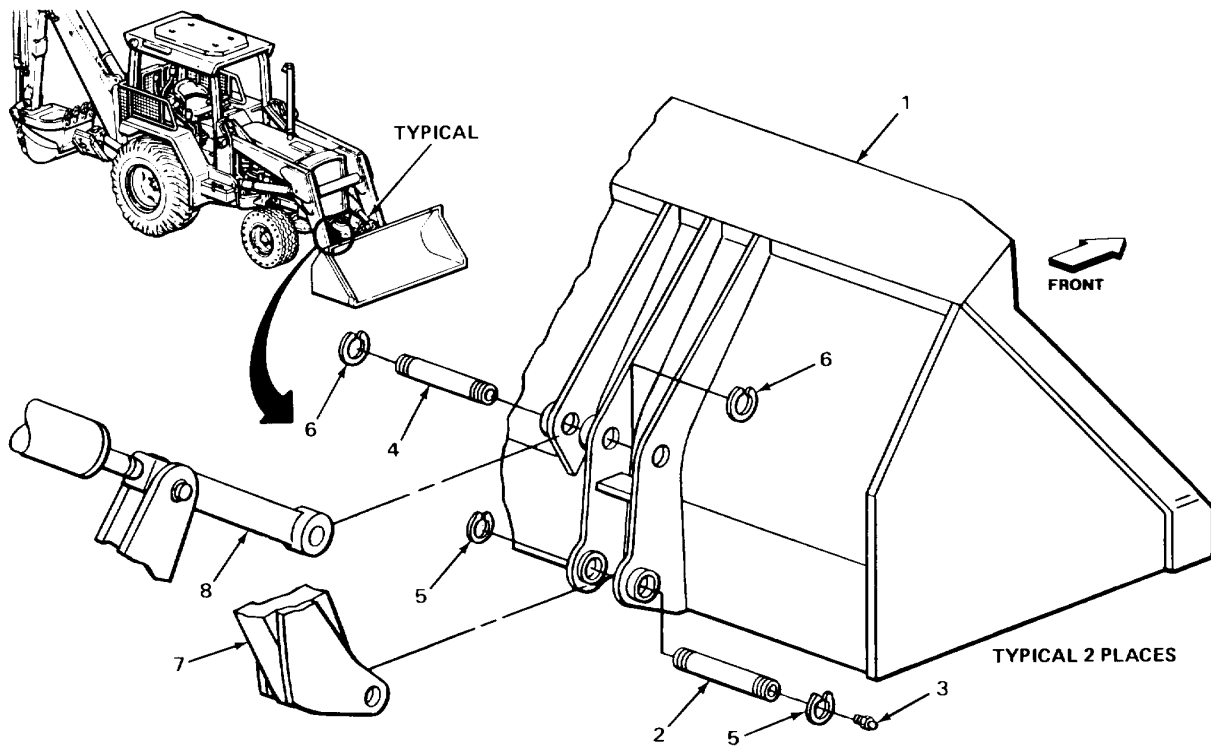

TA243617

LOADER BUCKET - CONTINUED

LOCATION	ITEM	ACTION	REMARKS
----------	------	--------	---------

INSPECTION/REPLACEMENT

NOTE

For more information on how to inspect parts, go to General Maintenance Instructions (page 2-137).

Replace defective parts which cannot be repaired.

10.	All parts	Look for cracks, breaks, and abnormal bends.
-----	-----------	--

REPAIR

11.	Loader bucket (1)	If cracked or broken, repair by welding (TM 9-237).
-----	-------------------	---

INSTALLATION

WARNING

Keep clear of hydraulic components when raised and not supported. Sudden loss of hydraulic pressure could cause components to drop without warning.

12.	Loader bucket (1)	Loader backhoe	Have assistant move forward into position (TM 5-2420-222-10).
13.		Lift arm (2)	Have assistant, by operating loader bucket control lever, aline pin holes.
14.	Loader bucket (1) and lift arm (2)	Two pins (3)	Using 3-pound head cross-peen hammer and 3/4-inch brass-tipped driftpin placed on end without grease fitting hole, drive in.
15.	Loader bucket (1)	Two bucket links (4)	Have assistant, by operating loader bucket lever, aline pin holes.
16.	Loader bucket (1) and two bucket links (4)	Two pins (5)	Using 3-pound head cross-peen hammer and 3/4-inch brass-tipped driftpin, drive in.
17.	Four pins (3 and 5)	Eight new rings (6 and 7)	Using retaining ring pliers, put on.

LOADER BUCKET - CONTINUED

LOCATION	ITEM	ACTION	REMARKS
----------	------	--------	---------

18. Two pins (3)	Two grease fittings (8)	Screw in and tighten using 7/16-inch, 1/4-inch drive socket, 2-inch extension, and ratchet handle.	
------------------	-------------------------	--	--

WARNING

Keep clear of hydraulic components when raised and not supported. Sudden loss of hydraulic pressure could cause components to drop without warning.

19. Loader backhoe	Loader bucket (1)	a. Have assistant raise (TM 5-2420-222-10). b. Take wood blocks out from underneath. c. Have assistant lower (TM 5-2420-222-10).	
--------------------	-------------------	--	--

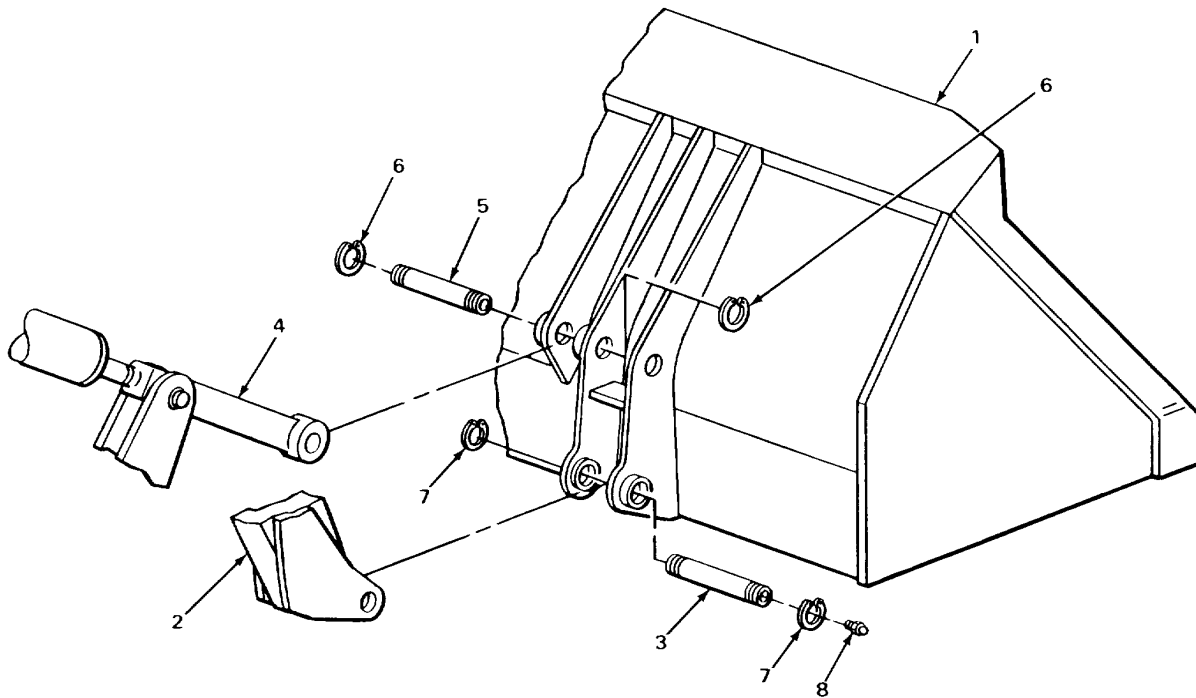

TASK ENDS HERE

TA243618

LOADER BUCKET LEVEL INDICATOR

This task covers:

- a. Removal (page 2-1838)
- b. Cleaning (page 2-1840)
- c. Inspection/Replacement (page 2-1840)
- d. Installation (page 2-1841)
- e. Adjustment (page 2-1842)

INITIAL SETUP

Tools

- Driftpin, brass-tipped, 3/4-inch
- Hammer, cross-peen, 3-pound head
- Handle, ratchet, 1/2-inch drive
- Lifting equipment, 1000-pound capacity
- Pliers, retaining ring
- Socket, 1/2-inch drive, 9/16-inch
- Wrench, open-end, 11/16-inch

Materials/Parts

- Lockwasher (two required)
- Rags, wiping (item 21, Appendix C)
- Solvent, drycleaning (item 28, Appendix C)

Personnel Required

Two

LOCATION	ITEM	ACTION	REMARKS
----------	------	--------	---------

REMOVAL

- | | | | |
|---|---|---|--|
| 1. Bucket indicator rod (1) | Nut (2) | a. Note number of exposed threads on rod (1).
b. Using 11/16-inch open-end wrench, unscrew and take off. | |
| 2. Indicator pivot (3) | Bucket indicator rod (1) with assembled nut (4) | Pull out. | |
| 3. Bucket indicator rod (1) | Nut (4) | Unscrew and take off. | |
| 4. Indicator guide tube (5) | Bucket indicator rod (1) | Pull out. | |
| 5. Indicator guide tube (5) and loader bucket cylinder head (6) | Two screws (7) and lockwashers (8) | a. Using 9/16-inch, 1/2-inch drive socket and ratchet handle, unscrew and take out.
b. Get rid of lockwashers (8). | |

LOADER BUCKET LEVEL INDICATOR - CONTINUED

LOCATION	ITEM	ACTION	REMARKS
6. Loader bucket cylinder head (6)	Indicator guide tube (5)	Take off.	
7. Pin (9)	Ring (10)	Using retaining ring pliers, take off.	

WARNING

Some parts are heavy. Be careful when handling them. Lifting equipment is needed when parts weigh over 50 pounds (23 kg) for a single person lift, over 100 pounds (45 kg) for a two person lift, and over 150 pounds (68 kg) for a three or more person lift. Do not try to handle heavy parts without lifting equipment. Keep clear of heavy parts supported only by lifting equipment. Failure to observe this precaution could cause serious injury or death of personnel.

- | | | |
|-------------------|--------------------|--|
| 8. Loader backhoe | Loader bucket (11) | Using 1000-pound capacity lifting equipment, support to take pressure off pin (9). |
|-------------------|--------------------|--|

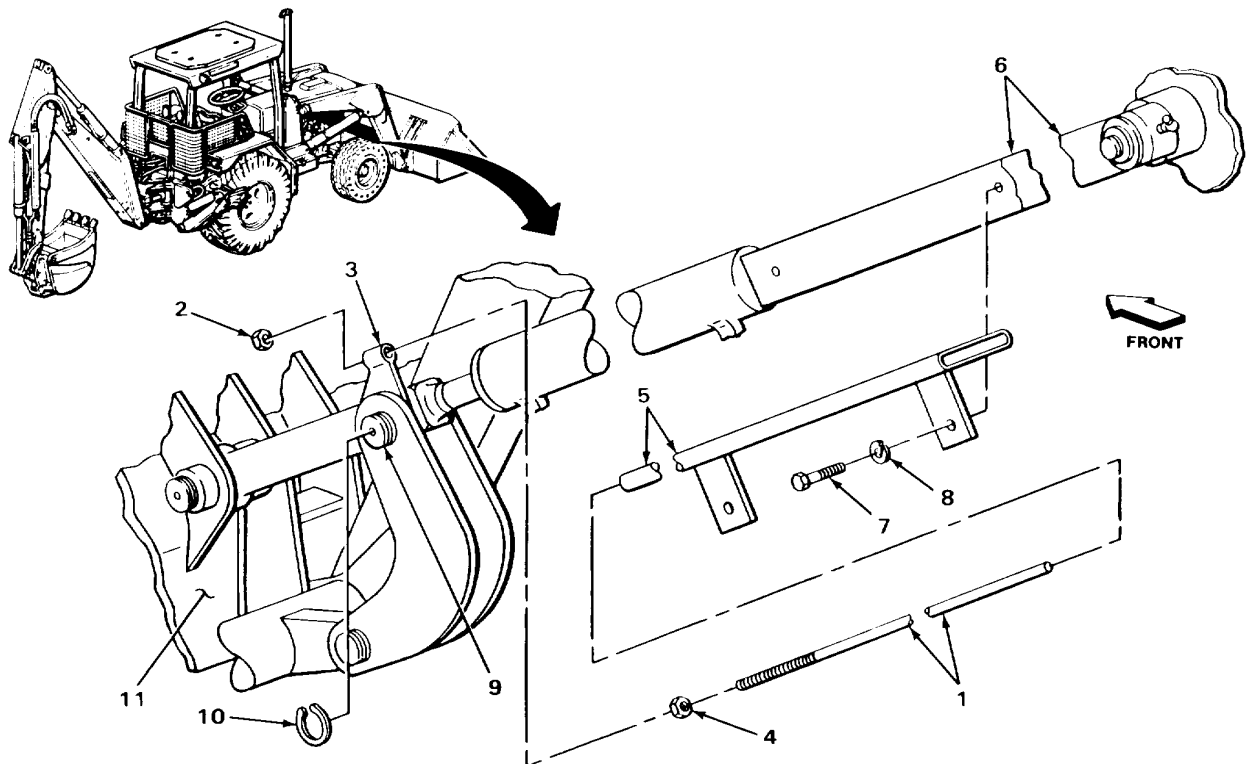

TA243619

LOADER BUCKET LEVEL INDICATOR - CONTINUED

LOCATION	ITEM	ACTION	REMARKS
REMOVAL - CONTINUED			
9.	Loader bucket cylinder piston rod (1), two front guide links (2 and 3), bucket link (4), and indicator pivot (5)	Pin (6)	a. Have assistant support link (3). b. Using 3-pound head cross-peen hammer and 3/4-inch brass-tipped driftpin, tap until clear of link (3).
10.	Loader bucket cylinder piston rod (1) and pin (6)	Indicator pivot (5) and guide link (3)	Take off.

CLEANING

NOTE

For more information on how to clean parts, go to General Maintenance Instructions (page 2-137).

WARNING

Drycleaning solvent P-D-680 is toxic and flammable. Wear protective goggles and gloves and use only in a well ventilated area. Avoid contact with skin, eyes, and clothes and don't breathe vapors. Do not use near open flame or excessive heat. The flashpoint is 100°F to 138°F (38° to 59°C). If you become dizzy while using cleaning solvent, get fresh air immediately and get medical aid. If contact with eyes is made, wash your eyes with water and get medical aid immediately.

- | | | |
|-----|-----------|---|
| 11. | All parts | a. Clean in drycleaning solvent.
b. Using clean, dry rags, wipe dry. |
|-----|-----------|---|

INSPECTION/REPLACEMENT

NOTE

For more information on how to inspect parts, go to General Maintenance Instructions (page 2-137).

Replace defective parts as needed.

- | | | |
|-----|-----------------|--|
| 12. | All metal parts | Look for cracks, breaks, and abnormal bends. |
|-----|-----------------|--|

LOADER BUCKET LEVEL INDICATOR - CONTINUED

LOCATION	ITEM	ACTION REMARKS
13.	All threaded parts	Look for damaged threads.
INSTALLATION		
14. Loader bucket cylinder piston rod (1) and pin (6)	Indicator pivot (5) and guide link (3)	Place in position.
15. Loader bucket cylinder piston rod (1), two front guide links (2 and 3), bucket link (4), and indicator pivot (5)	Pin (6)	a. Have assistant aline pin holes of link (3) and pivot (5). b. Using 3-pound head cross-peen hammer, tap into position.

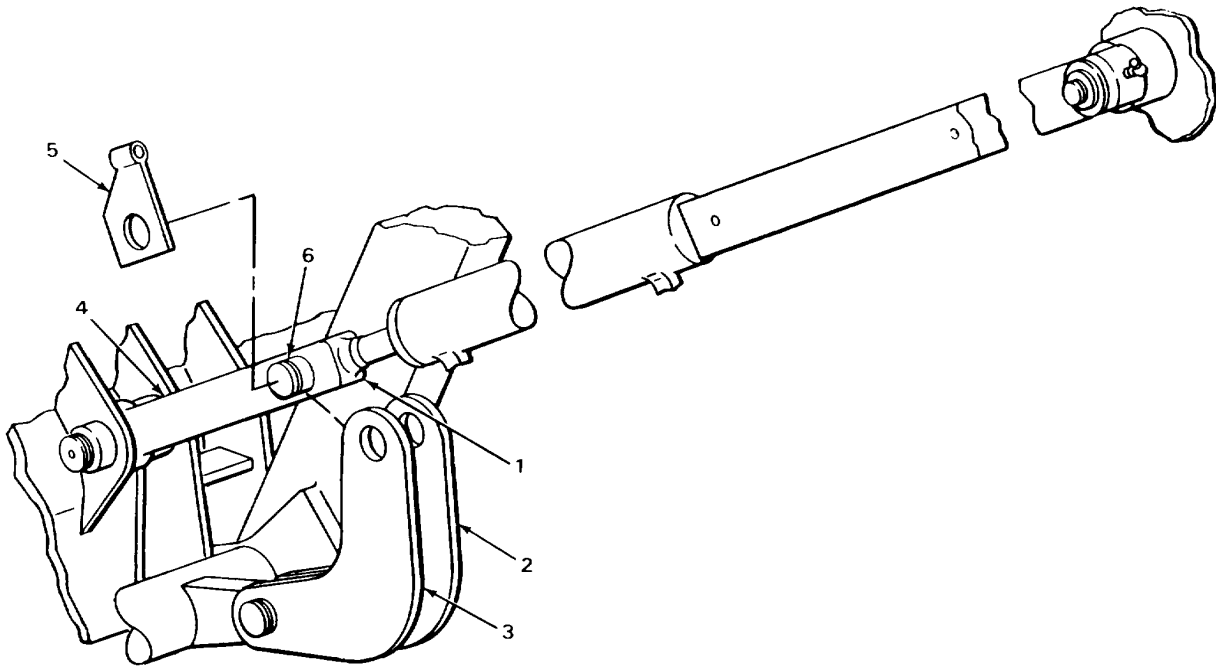

TA243620

LOADER BUCKET LEVEL INDICATOR - CONTINUED

LOCATION	ITEM	ACTION REMARKS	
INSTALLATION - CONTINUED			
16.	Pin (1)	Ring (2)	Using retaining ring pliers, put on.
17.	Loader bucket cylinder head (3)	Indicator guide tube (4)	Place in position.
18.	Indicator guide tube (4)	Two new lockwashers (5) and screws (6)	Screw in and tighten using 9/16-inch, 1/2-inch drive socket and ratchet handle.
19.		Bucket indicator rod (7)	Push in.
20.	Bucket indicator rod (7)	Nut (8)	Screw on as far as possible.
21.	Indicator pivot (9)	Bucket indicator rod (7) with assembled nut (8)	Push in until nut (8) is seated against pivot (9).
22.	Bucket indicator rod (7)	Nut (10)	Screw on until number of exposed threads on rod (7) are same as noted during removal.
23.	Bucket indicator rod (7) and indicator pivot (9)	Nut (8)	Using 11/16-inch open-end wrench, tighten against pivot (9).

ADJUSTMENT

NOTE

Loader backhoe must be parked on level ground with loader bucket resting on ground for correct adjustment to be made.

24.	Indicator guide tube (4)	Bucket indicator rod (7)	Note relative positions. Rod end should be flush with end of tube.
-----	--------------------------	--------------------------	--

NOTE

If end is flush with end of tube, skip steps 25 thru 27.

LOADER BACKHOE LEVEL INDICATOR - CONTINUED

LOCATION	ITEM	ACTION	REMARKS
25. Bucket indicator rod (7) and loosen indicator pivot (9)	Two nuts (8 and 10)	a. Using 11/16-inch open-end wrench, b. If rod end is inside indicator guide tube (4), screw forward along rod (7). c. If rod end is protruding from indicator guide tube (4), screw toward rear along rod (7).	
26. Indicator guide tube (4)	Bucket indicator rod (7)	a. Note relative positions. b. Repeat steps 25b, c, and 26 until end is flush with end of tube (4).	
27. Bucket indicator rod (7), and indicator pivot (9)	Two nuts (8 and 10) tighten.	Using 11/16-inch open-end wrench,	

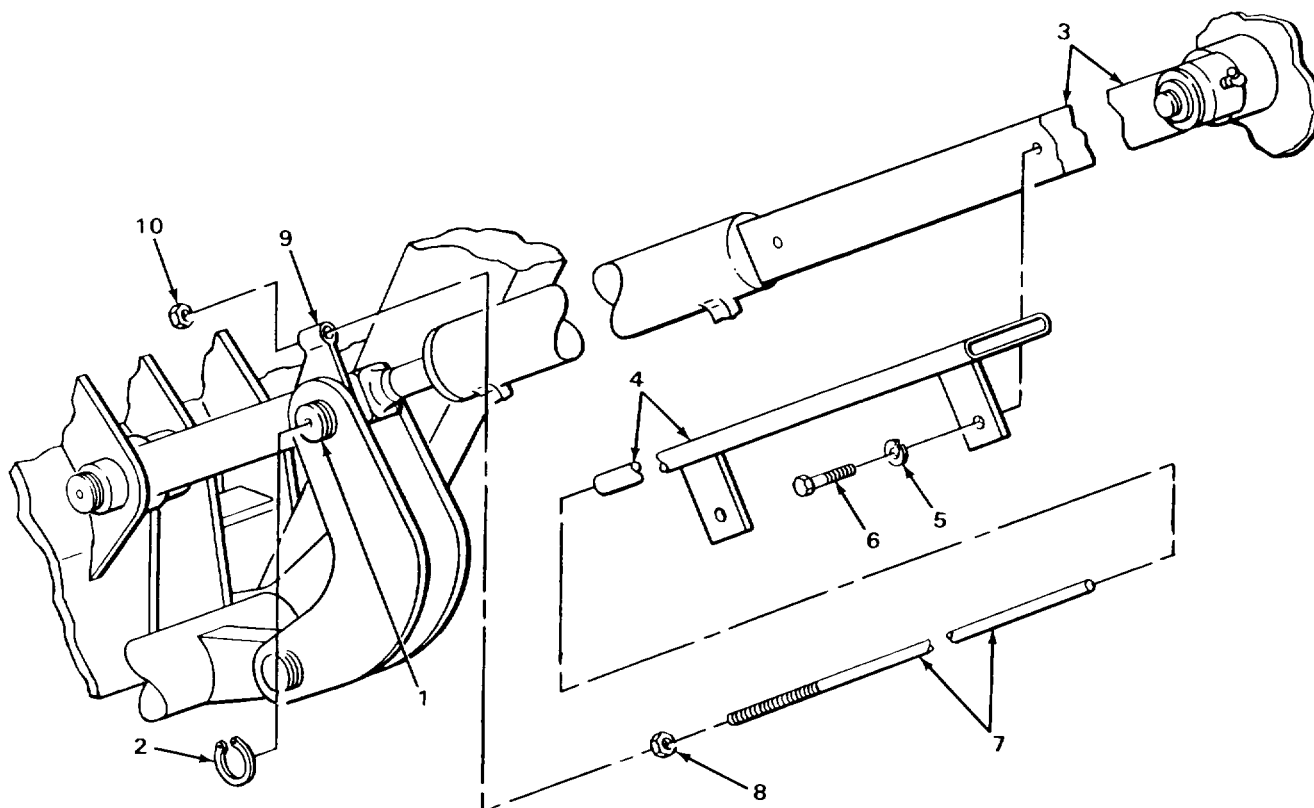

TASK ENDS HERE

LOADER BUCKET LINKAGE

This task covers:

- | | |
|---|-------------------------------|
| a. Removal (page 2-1844) | e. Repair (page 2-1848) |
| b. Disassembly (page 2-1846) | f. Assembly (page 2-1848) |
| c. Cleaning (page 2-1847) | g. Installation (page 2-1848) |
| d. Inspection/Replacement (page 2-1848) | |

INITIAL SETUP:

Tools

Driftpin, brass-tipped, 3/4-inch
 Hammer, cross-peen, 3-pound head
 Handle, ratchet, 1/4-inch drive
 Lifting equipment, 1000-pound
 capacity
 Pliers, retaining ring
 Press, arbor
 Remover and installer, 2-inch
 Socket, 1/4-inch drive, 7/16-inch
 Thread set, pipe

Materials/Parts

Rags, wiping (item 21, Appendix C)
 Solvent, drycleaning (item 28, Appendix C)

Personnel Required

Two

LOCATION	ITEM	ACTION	REMARKS
----------	------	--------	---------

NOTE

Loader backhoe has two sets of loader bucket linkage. Both are maintained the same way except as noted. Right side is shown. Repeat procedures for left side as needed.

REMOVAL

- | | | |
|--|----------------------|--|
| 1. Loader bucket (1)
and pin (2) | Two rings (3) | Using retaining ring pliers, take off. |
| 2. Two front guide
links (4 and 5)
and two pins
(6 and 7) | Four rings (8 and 9) | Using retaining ring pliers, take off. |

LOADER BUCKET LINKAGE - CONTINUED

LOCATION	ITEM	ACTION	REMARKS
----------	------	--------	---------

WARNING

Some parts are heavy. Be careful when handling them. Lifting equipment is needed when parts weigh over 50 pounds (23 kg) for a single person lift, over 100 pounds (45 kg) for a two person lift, and over 150 pounds (68 kg) for a three or more person lift. Do not try to handle heavy parts without lifting equipment. Keep clear of heavy parts supported only by lifting equipment. Failure to observe this precaution could cause serious injury or death of personnel.

3. Loader backhoe	Loader bucket (1)	Using 1000-pound capacity lifting equipment, support to take pressure off pins (2, 6, and 7).
-------------------	-------------------	---

NOTE

Right side bucket linkage has indicator pivot, left side bucket linkage has washer.

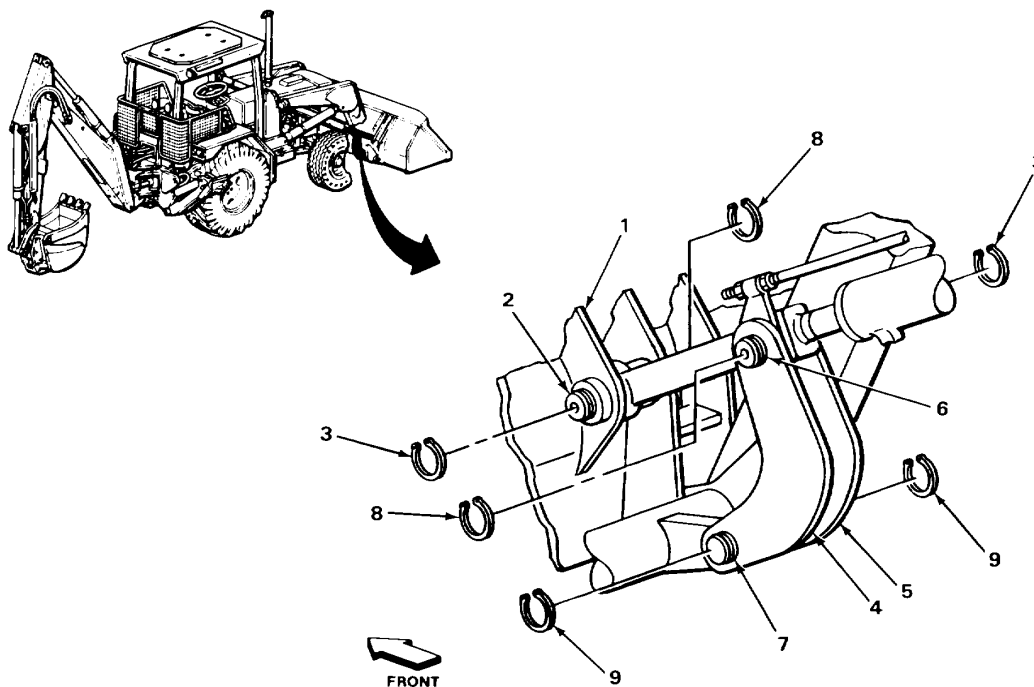

TA243622

LOADER BUCKET LINKAGE -CONTINUED

LOCATION	ITEM	ACTION REMARKS	
REMOVAL - CONTINUED			
4.	Two front guide links (1 and 2), bucket link (3), indicator pivot (4) or washer (5), and loader bucket cylinder piston rod (6)	Pin (7)	Using 3-pound head cross-peen hammer and 3/4-inch brass-tipped driftpin, drive out.
5.	Loader bucket cylinder piston rod (6)	Two front guide links (1 and 2), indicator pivot (4) or washer (5), and bucket link (3)	Take off.
6.	Bucket link (3) and loader bucket (8)	Pin (9)	Using 3-pound head cross-peen hammer and 3/4-inch brass-tipped driftpin, drive out.
7.	Loader bucket (8)	Bucket link (3)	Take out.
8.	Two front guide links (1 and 2) and lift arms (10)	Pin (11)	Using 3-pound head cross-peen hammer and 3/4-inch brass-tipped driftpin, drive out.
9.	Lift arms (10)	Two front guide links (1 and 2)	Take off.

DISASSEMBLY

CAUTION

Do not remove bushings unless inspection shows need for replacement. Removal may damage parts.

10.	Bucket link (3)	Three bushings (12, 13, and 14)	Using arbor press and 2-inch remover and installer, press out.
11.		Grease fitting (15)	Using 7/16-inch, 1/4-inch drive socket and ratchet handle, unscrew and take out.

LOADER BUCKET LINKAGE - CONTINUED

LOCATION	ITEM	ACTION	REMARKS
----------	------	--------	---------

CLEANING

NOTE

For more information on how to clean parts, go to General Maintenance Instructions (page 2-137).

WARNING

Drycleaning solvent P-D-680 is toxic and flammable. Wear protective goggles and gloves and use only in a well ventilated area. Avoid contact with skin, eyes, and clothes and don't breathe vapors. Do not use near open flame or excessive heat. The flashpoint is 100°F to 138°F (38° to 59°C). If you become dizzy while using cleaning solvent, get fresh air immediately and get medical aid. If contact with eyes is made, wash your eyes with water and get medical aid immediately.

- | | | |
|-----|-----------------|---|
| 12. | All metal parts | <ul style="list-style-type: none"> a. Clean in drycleaning solvent. b. Using clean, dry rags, wipe dry. |
|-----|-----------------|---|

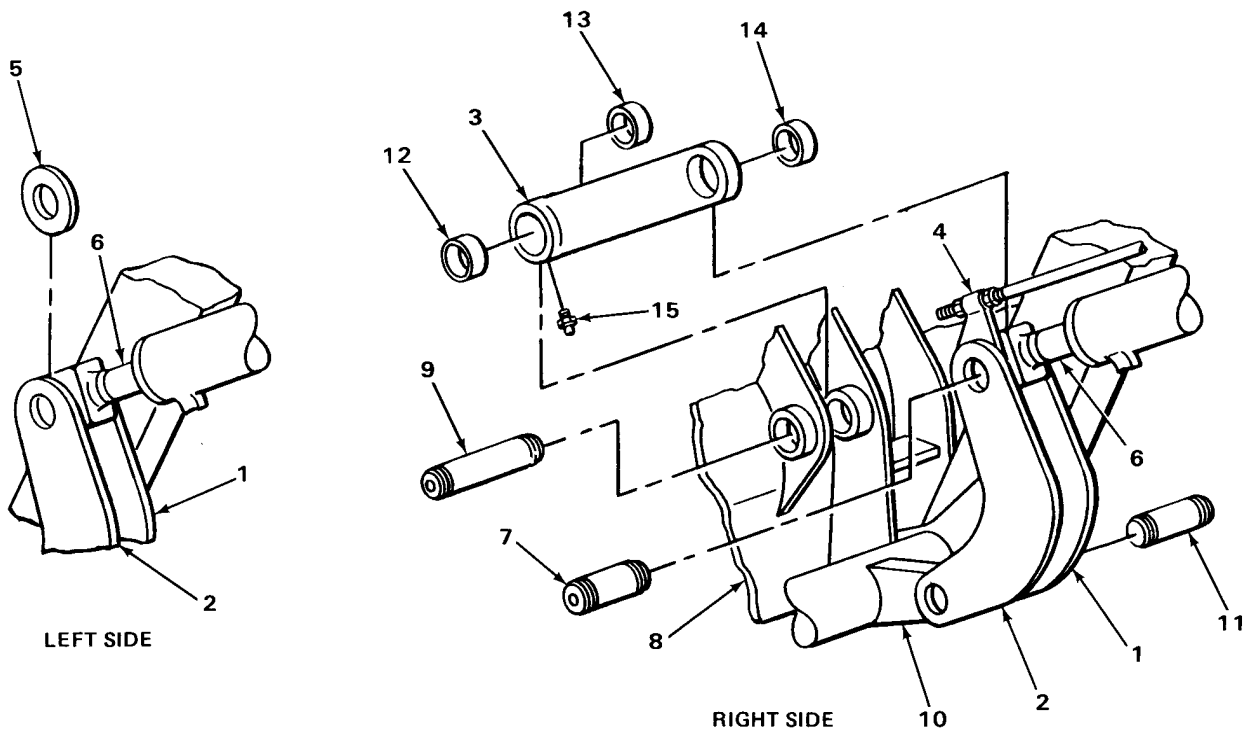

TA243623

LOADER BUCKET LINKAGE - CONTINUED

LOCATION	ITEM	ACTION	REMARKS
INSPECTION/REPLACEMENT			
NOTE			
For more information on how to inspect parts, go to General Maintenance Instructions (page 2-137).			
Replace defective parts which cannot be repaired.			
13.	All threaded parts		Look for damaged threads.
14.	All metal parts		Look for cracks, breaks, burrs, and abnormal bends.
REPAIR			
15.	Bucket link (1)		If threads are damaged, using pipe thread set, restore threads.
ASSEMBLY			
16.	Bucket link (1)	Grease fitting (2)	Screw in and tighten using 7/16-inch, 1/4-inch drive socket and ratchet handle.
17.	Three bushings (3, 4, and 5)		If removed, using arbor press and 2-inch remover and installer, push in.
INSTALLATION			
18.	Lift arms (6)	Two front guide links (7 and 8)	Place in position.
19.	Lift arms (6) two front guide links (7 and 8)	and Pin (9)	a. Have assistant aline pin holes of arms (6) and links (7 and 8). b. Using 3-pound head cross-peen hammer, tap in.
20.	Loader bucket (10)	Bucket link (1)	Place in position.
21.	Loader bucket (10) and bucket link (1)	Pin (11) bucket (10) and link (1).	a. Have assistant aline pin holes of b. Using 3-pound head cross-peen hammer, tap in.

LOADER BUCKET LINKAGE - CONTINUED

LOCATION	ITEM	ACTION	REMARKS
----------	------	--------	---------

NOTE

Right side bucket linkage has indicator pivot, left side bucket linkage has washer.

- | | | | |
|---|---|--|--|
| 22. Loader bucket cylinder piston rod (12) | Two front guide links (7 and 8), indicator pivot (13) or washer (14), and bucket link (1) | Place in position. | |
| 23. Two front guide links (7 and 8), bucket link (1), indicator pivot (13) or washer (14), loader bucket cylinder piston rod (12) | Pin (15) | <ul style="list-style-type: none"> a. Have assistant aline pin holes of links (1, 7, and 8), pivot (13) or washer (14), and rod (12). b. Using 3-pound head cross-peen and hammer, tap in. | |

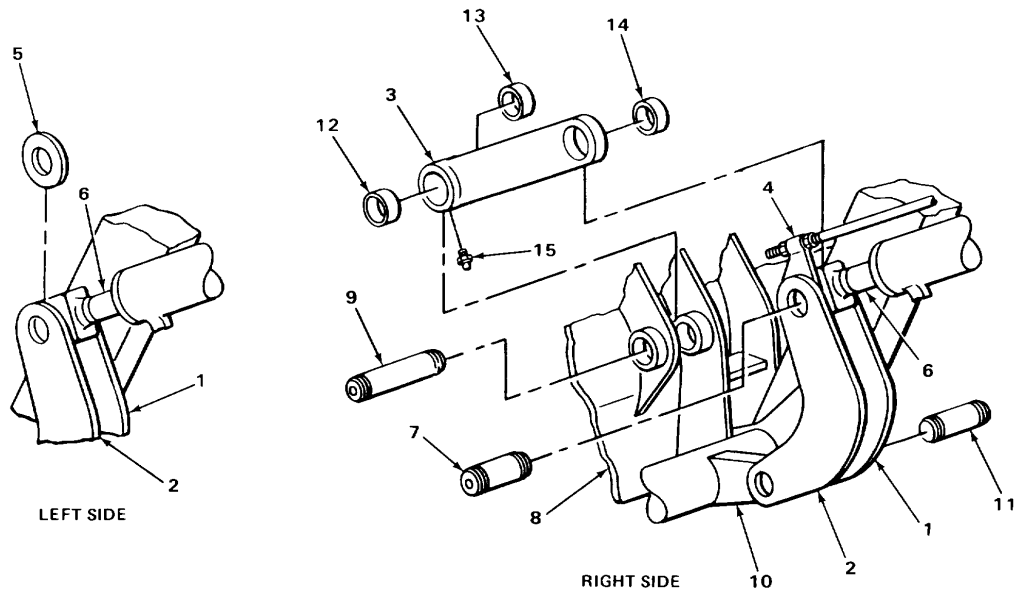

TA243623

LOADER BUCKET LINKAGE - CONTINUED

LOCATION	ITEM	ACTION	REMARKS
INSTALLATION - CONTINUED			
24. Two front guide links (1 and 2) and two pins (3 and 4)	Four rings (5 and 6)	Using retaining ring pliers, put on.	
25. Loader bucket (7) and pin (8)	Two rings (9)	a. Using retaining ring pliers, put on. b. Take off 1000-pound capacity lifting equipment.	

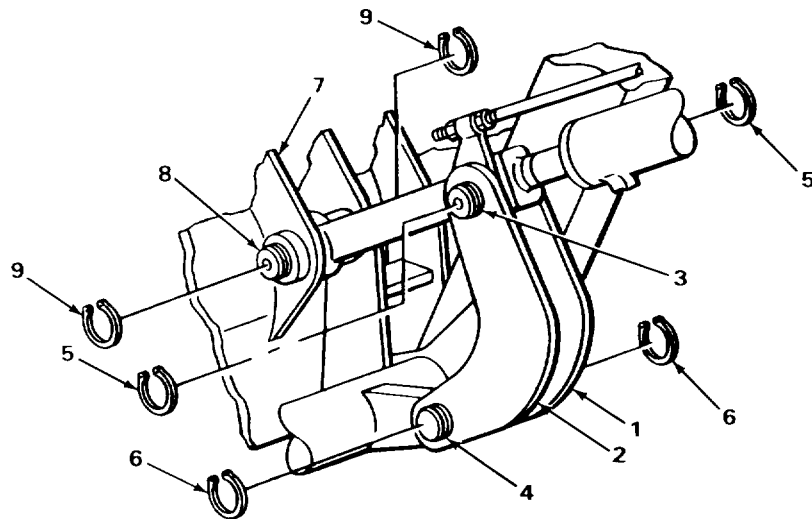

TASK ENDS HERE

TA243625

Section XXIII. FIRE FIGHTING EQUIPMENT COMPONENTS

	Page		Page
Fire Extinguisher.....	2-1851	Fire Extinguisher Mounting Bracket.....	2-1852

FIRE EXTINGUISHER

This task covers:

Inspection/Replacement (page 2-1851)

INITIAL SETUP:

Equipment Condition

Fire extinguisher removed (TM 5-2420-222-10)

LOCATION	ITEM	ACTION	REMARKS
-----------------	-------------	---------------	----------------

INSPECTION/REPLACEMENT

NOTE

For inspection and replacement standards for fire extinguishers, see TB 5-4200-200-10.

FOLLOW-ON MAINTENANCE: Install fire extinguisher (TM 5-2420-222-10).

TASK ENDS HERE

FIRE EXTINGUISHER MOUNTING BRACKET

This task covers:

- | | |
|---------------------------|---|
| a. Removal (page 2-1852) | c. Inspection/Replacement (page 2-1853) |
| b. Cleaning (page 2-1852) | d. Installation (page 2-1854) |

INITIAL SETUP:

Tools	Personnel Required
Screwdriver, cross-tip, number 2	One
Materials/Parts	Equipment Condition
Rags, wiping (item 21, Appendix C) Solvent, drycleaning (item 28, Appendix C)	Fire extinguisher removed (TM 5-2420-222-10)

LOCATION	ITEM	ACTION REMARKS
REMOVAL		
1. Left fender (1) and bracket (2)	Four screws (3)	Using number 2 cross-tip screwdriver, unscrew and take out.
2. Left fender (1) Bracket (2)		Take off.

CLEANING

NOTE

For more information on how to clean parts, go to General Maintenance Instructions (page 2-137).

WARNING

Drycleaning solvent P-D-680 is toxic and flammable. Wear protective goggles and gloves and use only in a well ventilated area. Avoid contact with skin, eyes, and clothes and don't breathe vapors. Do not use near open flame or excessive heat. The flashpoint is 100°F to 138°F (38° to 59°C). If you become dizzy while using cleaning solvent, get fresh air immediately and get medical aid. If contact with eyes is made, wash your eyes with water and get medical aid immediately.

FIRE EXTINGUISHER MOUNTING BRACKET - CONTINUED

LOCATION	ITEM	ACTION	REMARKS
3.	All metal parts	a. Clean in drycleaning solvent. b. Using clean, dry rags, wipe dry.	

INSPECTION/REPLACEMENT

NOTE

For more information on how to inspect parts, go to General Maintenance Instructions (page 2-137).

Replace defective parts as needed.

- | | | |
|----|-----------------|--|
| 4. | Bracket (2) | Look for cracks, breaks, and abnormal bends. |
| 5. | Four screws (3) | Look for cracks, bends, breaks, and damaged threads. |

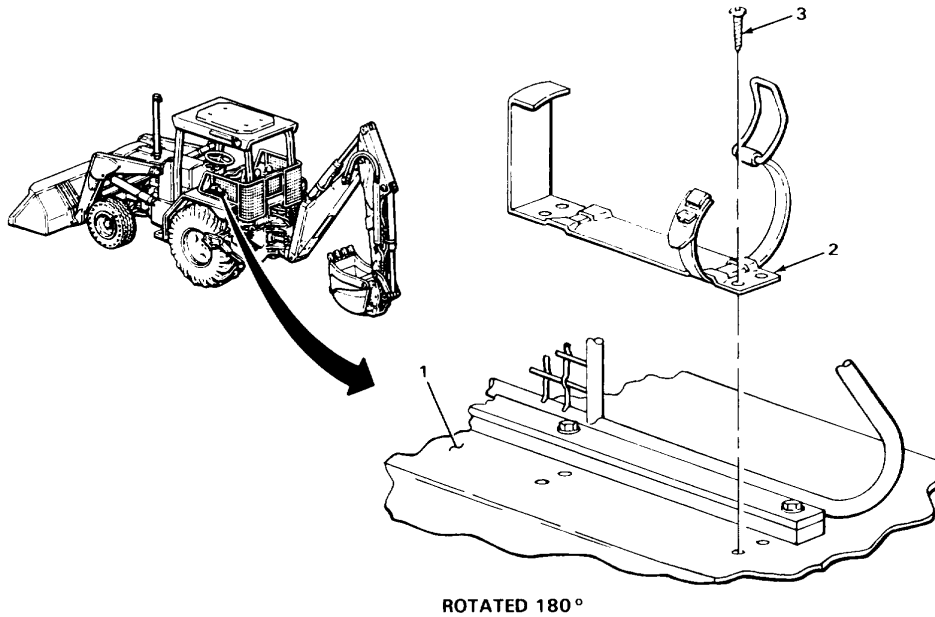

TA243626A

FIRE EXTINGUISHER MOUNTING BRACKET - CONTINUED

LOCATION	ITEM	ACTION	REMARKS
----------	------	--------	---------

INSTALLATION

- | | | | |
|---------------------------------------|-----------------|--|--|
| 6. Left fender (1) | Bracket (2) | Place in position. | |
| 7. Left fender (1)
and bracket (2) | Four screws (3) | Using number 2 cross-tip screwdriver,
screw in and tighten. | |

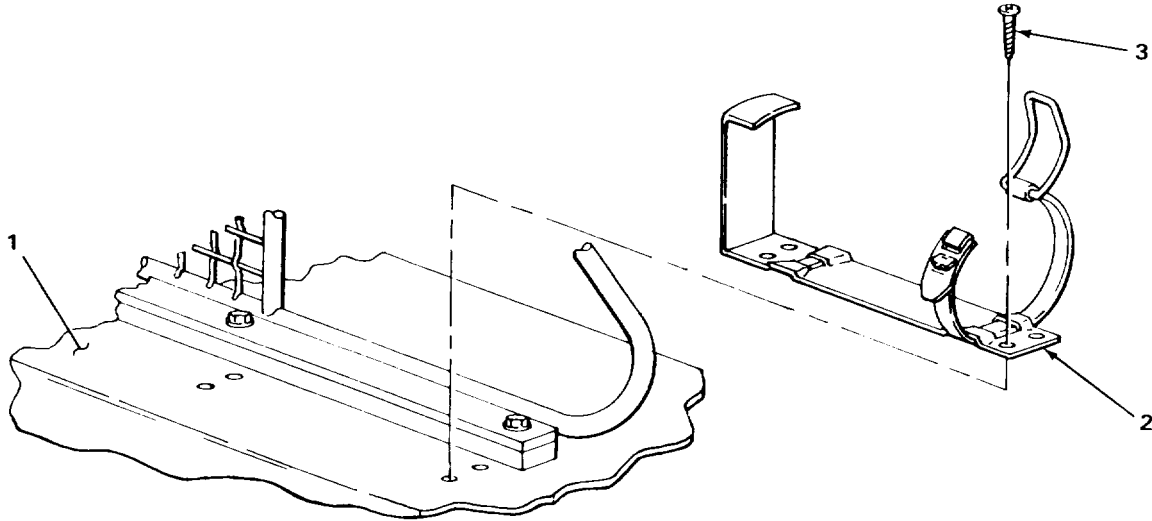

NOTE

FOLLOW-ON MAINTENANCE: Install fire extinguisher (TM 52420-222-10).

TASK ENDS HERE

TA243626B

Section XXIV. PARTS PECULIAR

Page	Page
Hydraulic Earth Drill Auger 2-1866	Hydraulic Impactor Lines and Fittings..... 2-1879
Hydraulic Earth Drill Boring Head 2-1870	Hydraulic Impactor Mounting Adapter..... 2-1883
Hydraulic Earth Drill Hoses and Fittings 2-1855	Hydraulic Impactor Working Tools 2-1888
Hydraulic Earth Drill Mounting Adapter 2-1862	
Hydraulic Impactor and Motor Assembly 2-1893	

HYDRAULIC EARTH DRILL HOSES AND FITTINGS

This task covers:

- | | |
|------------------------------|---|
| a. Removal (page 2-1856) | d. Inspection/Replacement (page 2-1858) |
| b. Disassembly (page 2-1858) | e. Assembly (page 2-1859) |
| c. Cleaning (page 2-1858) | f. Installation (page 2-1860) |

INITIAL SETUP:

Tools

- Container, flexible, 1-gallon
- Handle, ratchet, 1/2-inch drive
- Knife, pocket
- Socket, 1/2-inch drive, 11/16-inch
- Wrench, open-end, 9/16-inch
- Wrench, open-end, 3/4-inch
- Wrench, open-end, 11/16-inch
- Wrench, open-end, 7/8-inch
- Wrench, open-end, 1 1/8-inch
- Wrench, open-end, 1 1/2-inch
- Tags, marking (item 30, Appendix C)

NOTE

The following tools only apply to loader backhoes with Serial Numbers 235786 thru 235999.

- Socket, 1/2-inch drive
- Wrench, open-end

NOTE

The following tools only apply to loader backhoes with Serial Numbers 319995 thru 342573.

Tools - Continued

- Socket, 1/2-inch drive, 1 1/4-inch
- Wrench, open-end, 1-inch

Materials/Parts

- Detergent, GP (item 7, Appendix C)
- Packing, adapter (two required)
- Packing, elbow
- Rags, wiping (item 21, Appendix C)
- Solvent, drycleaning (item 28, Appendix C)

Personnel Required

One

Equipment Condition

Hydraulic Earth Auger Attachment removed (TM 5-2420-222-10)

HYDRAULIC EARTH DRILL HOSES AND FITTINGS - CONTINUED

LOCATION	ITEM	ACTION	REMARKS
REMOVAL			
NOTE			
Steps 1 and 2 only apply to loader backhoes with Serial Numbers 235786 thru 235999.			
1. Two bushings (1)	Two hoses (2 and 3)	a.	Place 1-gallon flexible container underneath.
		b.	Using 3/4-inch open-end wrench, unscrew and take out.
		c.	Tag (page 2-137).
2. Boring head (4)	Two bushings (1) with assembled packings (5)	a.	Using 1/2-inch drive socket and ratchet handle, unscrew and take out.
		b.	Plug boring head (4) (page 2-137).
NOTE			
Steps 3 and 4 only apply to loader backhoes with Serial Numbers 319995 thru 342573.			
3. Two straight adapters (6)	Two hoses (2 and 3)	a.	Place 1-gallon flexible container underneath.
		b.	Using 7/8-inch and 1-inch open-end wrenches, unscrew and take out.
		c.	Tag (page 2-137).
4. Boring head (4)	Two straight adapters (6) with assembled packings (5)	a.	Using 1 1/4-inch, 1/2-inch drive socket and ratchet handle, unscrew and take out.
		b.	Plug boring head (4) (page 2-137).
5. Straight adapter (7)	Hose (8)	a.	Place 1-gallon flexible container underneath.
		b.	Using 9/16-inch and 11/16-inch open-end wrenches, unscrew and take out.
		c.	Tag (page 2-137).
6. Elbow (9)	Straight adapter (7)	a.	Using 11/16-inch, 1/2-inch drive socket and ratchet handle, unscrew and take out.

HYDRAULIC EARTH DRILL HOSES AND FITTINGS - CONTINUED

LOCATION	ITEM	ACTION	REMARKS
7. Boring head (4)	Elbow (9) with assembled packing (10)	a. Note relative position for proper placement during installation. b. Using 3/4-inch open-end wrench, unscrew and take out. c. Plug boring head (4) (page 2-137). d. Get rid of drained fluid (page 2-137).	
8. Elbow (9)	Packing (10)	a. Using pocket knife, pry off. b. Get rid of.	

NOTE

Loader backhoes with Serial Numbers 235786 thru 235999 have bushings. Loader backhoes with Serial Numbers 319995 thru 342573 have straight adapters.

9. Two bushings (1) or straight adapters (2)	Two packings (5)	a. Using pocket knife, pry off. b. Get rid of.	
--	------------------	---	--

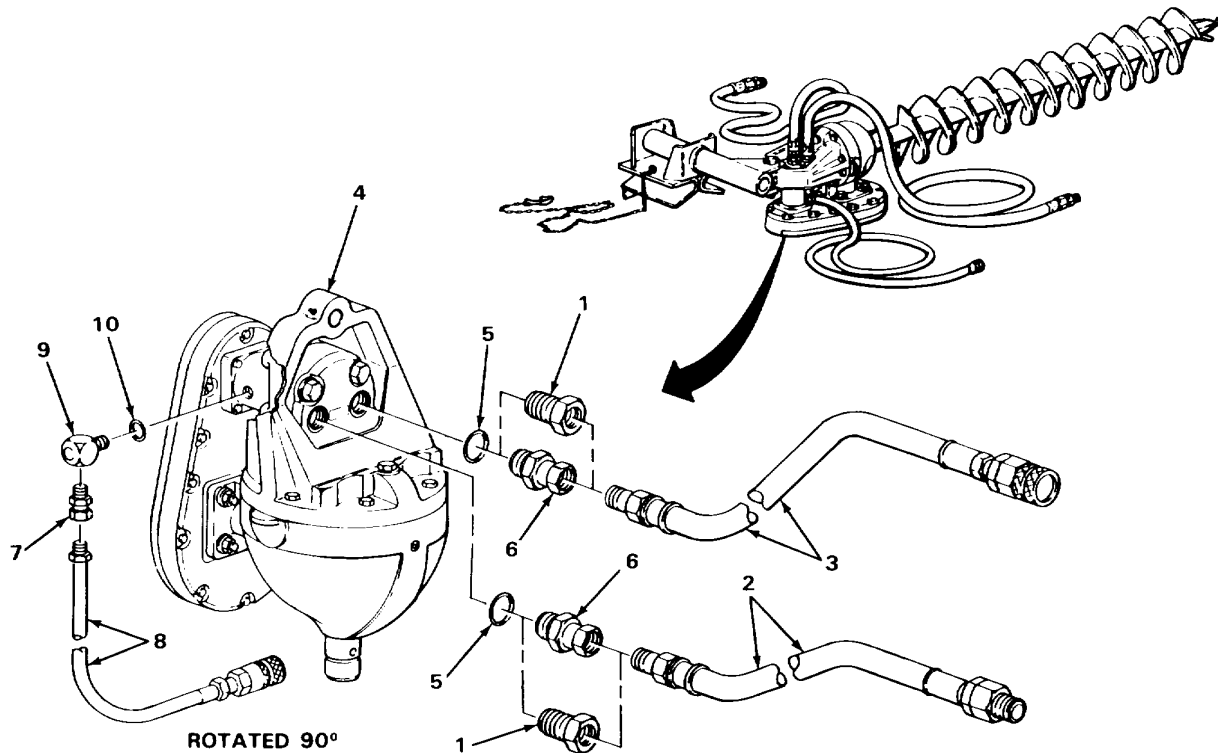

TA243627A

HYDRAULIC EARTH DRILL HOSES AND FITTINGS - CONTINUED

LOCATION	ITEM	ACTION REMARKS
DISASSEMBLY		
10. Hose (1)	Quick coupler (2)	Using 3/4-inch and 9/16-inch open-end wrenches, unscrew and take out.
11. Two adapters (3 and 4)	Male quick coupler (5) and female quick coupler (6)	a. Tag (page 2-137). b. Using 1 1/8-inch and 1 1/2-inch open-end wrenches, unscrew and take off.
12. Two hoses (7 and 8)	Two adapters (3 and 4)	Using 1 1/8-inch and 7/8-inch open-end wrenches, unscrew and take off.
CLEANING		
NOTE		
For more information on how to clean parts, go to General Maintenance Instructions (page 2-137).		
13.	All hoses	a. Using clean rags dampened in solution of detergent and water, wipe clean. b. Using clean rags dampened with clean water, rinse. c. Using clean, dry rags, wipe dry.
WARNING		
Drycleaning solvent P-D-680 is toxic and flammable. Wear protective goggles and gloves and use only in a well ventilated area. Avoid contact with skin, eyes, and clothes and don't breathe vapors. Do not use near open flame or excessive heat. The flashpoint is 100°F to 138°F (38° to 59°C). If you become dizzy while using cleaning solvent, get fresh air immediately and get medical aid. If contact with eyes is made, wash your eyes with water and get medical aid immediately.		
14.	All metal parts	a. Clean in drycleaning solvent. b. Using clean, dry rags, wipe dry.

INSPECTION/REPLACEMENT

NOTE**For more information on how to inspect parts, go to General Maintenance Instructions (page 2-1371).****Replace defective parts as needed.**

HYDRAULIC EARTH DRILL HOSES AND FITTINGS - CONTINUED

LOCATION	ITEM	ACTION REMARKS
15.	All hoses	Look for cuts, cracks, and breaks.
16.	All threaded parts	Look for cracks, breaks, abnormal bends, and damaged threads.
ASSEMBLY		
17. Two hoses (7 and 8)	Two adapters (3 and 4)	Screw on and tighten using 1 1/8-inch and 7/8-inch open-end wrenches.
18. Two adapters (3 and 4)	Male quick coupler (5) and female quick coupler (6)	a. Take off tags. b. Screw on and tighten using 1 1/8-inch and 1 1/2-inch open-end wrenches.
19. Hose (1)	Quick coupler (2)	Screw on and tighten using 3/4-inch and 9/16-inch open-end wrenches.

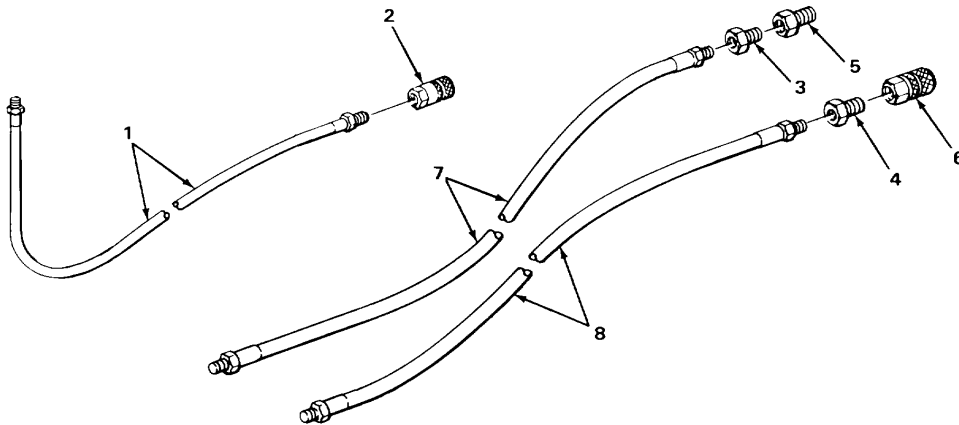

TA243627B

HYDRAULIC EARTH DRILL HOSES AND FITTINGS - CONTINUED

LOCATION	ITEM	ACTION	REMARKS
INSTALLATION			
NOTE			
Loader backhoes with Serial Numbers 235786 thru 235999 have bushings. Loader backhoes with Serial Numbers 319995 thru 342573 have straight adapters.			
20.	Two bushings (1) or straight adapters (2)	Two new packings (3)	Put on.
21.	Elbow (4)	New packing (5)	Put on.
22.	Boring head (6)	Elbow (4) with assembled packing (5)	a. Unplug boring head (6). b. Screw in and tighten to position noted during removal using 7/8-inch open-end wrench.
23.	Elbow (4)	Straight adapter (7)	Screw in and tighten using 11/16-inch, 1/2-inch drive socket and ratchet handle.
24.	Straight adapter (7)	Hose (8)	a. Take off tag. b. Screw in and tighten using 9/16-inch and 11/16-inch open-end wrenches.
NOTE			
Steps 25 and 26 only apply to loader backhoes with Serial Numbers 319995 thru 342573.			
25.	Boring head (6)	Two straight adapters (2) with assembled packings (3)	a. Unplug boring head (6). b. Screw in and tighten using 1 1/4-inch, 1/2-inch drive socket and ratchet handle.
26.	Two straight adapters (2)	Two hoses (9 and 10)	a. Take off tag. b. Screw in and tighten using 7/8-inch and 1-inch open-end wrenches.
NOTE			
Steps 27 and 28 only apply to loader backhoes with Serial Numbers 235786 thru 235999.			
27.	Boring head (6)	Two bushings (1) with assembled packings (3)	a. Unplug boring head (6). b. Screw in and tighten using 1/2-inch drive socket and ratchet handle.

HYDRAULIC EARTH DRILL HOSES AND FITTINGS - CONTINUED

LOCATION	ITEM	ACTION	REMARKS
----------	------	--------	---------

28. Two bushings (1)

Two hoses
(9 and 10)

- a. Take off tags.
- b. Screw in and tighten using 3/4-inch open-end wrench.

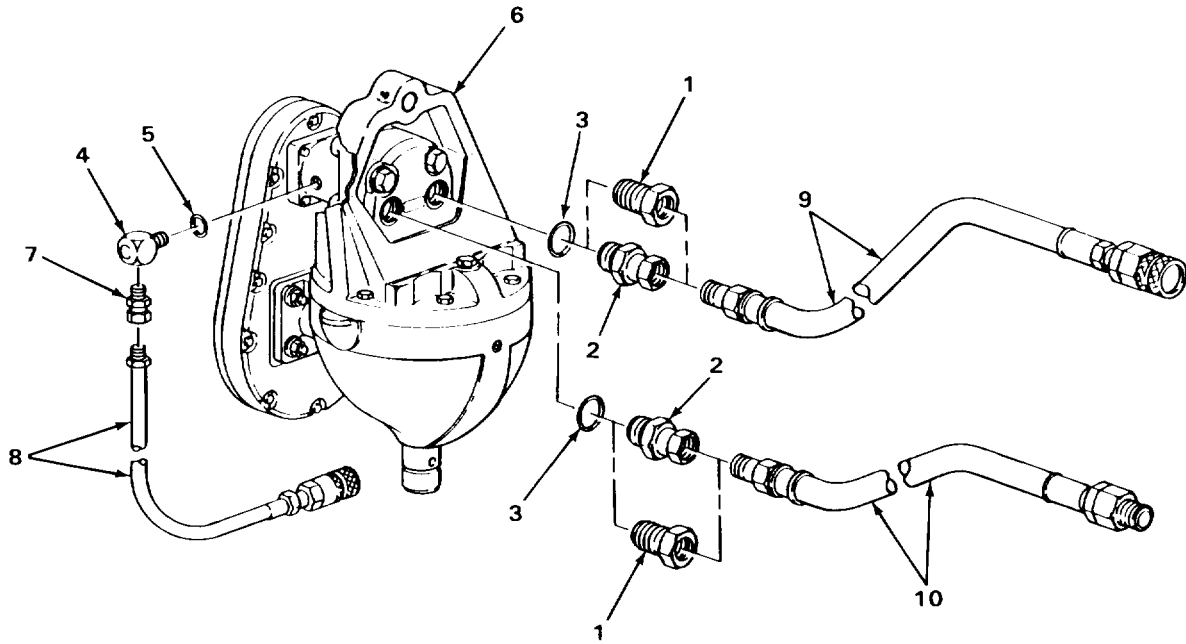

TASK ENDS HERE

TA243628

HYDRAULIC EARTH DRILL MOUNTING ADAPTER

This task covers:

- | | |
|------------------------------|---|
| a. Removal (page 2-1862) | d. Inspection/Replacement (page 2-1864) |
| b. Disassembly (page 2-1862) | e. Assembly (page 2-1864) |
| c. Cleaning (page 2-1863) | f. Installation (page 2-1864) |

INITIAL SETUP:

Tools

Driftpin, brass-tipped, 3/4-inch
 Hammer, ball-peen, 2-pound head
 Pliers, slip-joint, multiple tongue
 and groove
 Wrench, open-end, 9/16-inch
 (two required)

Materials/Parts - Continued

Rags, wiping (item 21, Appendix C)
 Solvent, drycleaning (item 28, Appendix C)

Two

Materials/Parts

Locknut, tube bolt
 Pins, cotter, tube pin (two required)

Equipment Condition

Hydraulic earth auger attachment removed
 (TM 5-2420-222-10)

LOCATION	ITEM	ACTION	REMARKS
----------	------	--------	---------

REMOVAL

- | | | |
|---|--|--|
| 1. Adapter tube (1)
and pin (2) | Two cotter pins (3) | a. Using multiple tongue and groove slip-joint pliers, straighten ends and take out.
b. Get rid of. |
| 2. Adapter tube (1)
and boring
head (4) | Pin (2) | Using 2-pound head ball-peen hammer and 3/4-inch brass-tipped driftpin, drive out. |
| 3. Boring head (4) | Adapter tube (1)
with assembled parts | Take off. |

DISASSEMBLY

- | | | |
|--|--------------------------------|---|
| 4. Adapter tube (1)
and adapter (5) | Bolt (6) and a.
locknut (7) | a. Using two 9/16-inch open-end wrenches, unscrew and take apart.
b. Get rid of locknut (7). |
| 5. Adapter (5) | Adapter tube (1) | Pull out. |

HYDRAULIC EARTH DRILL MOUNTING ADAPTER - CONTINUED

LOCATION	ITEM	ACTION	REMARKS
6.	Linch pin (8)	Unlatch and pull out.	
7.	Chain (9)	Take off.	

CLEANING

NOTE

For more information on how to clean parts, go to **General Maintenance Instructions (page 2-137)**.

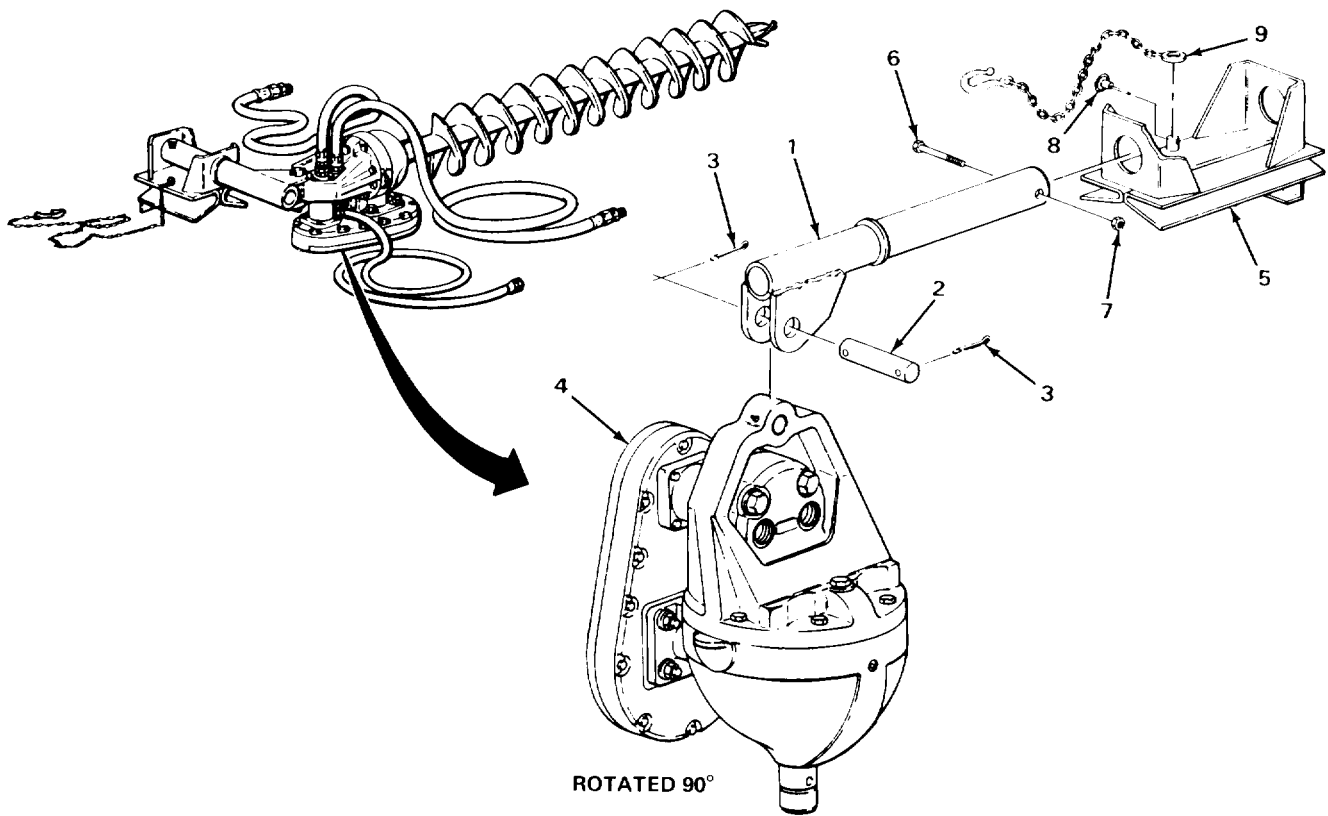

TA243629

HYDRAULIC EARTH DRILL MOUNTING ADAPTER - CONTINUED

LOCATION	ITEM	ACTION	REMARKS
CLEANING - CONTINUED			
WARNING			
<p>Drycleaning solvent P-D-680 is toxic and flammable. Wear protective goggles and gloves and use only in a well ventilated area. Avoid contact with skin, eyes, and clothes and don't breathe vapors. Do not use near open flame or excessive heat. The flashpoint is 100°F to 138°F (38° to 59°C). If you become dizzy while using cleaning solvent, get fresh air immediately and get medical aid. If contact with eyes is made, wash your eyes with water and get medical aid immediately.</p>			
8.	Adapter tube (1) and adapter (2)	a. Using clean rags dampened in dry-cleaning solvent, wipe clean. b. Using clean, dry rags, wipe dry.	
9.	All other parts	a. Clean in drycleaning solvent. b. Using clean, dry rags, wipe dry.	
INSPECTION/REPLACEMENT			
NOTE			
<p>For more information on how to inspect parts, go to General Maintenance Instructions (page 2-137).</p> <p>Replace defective parts as needed.</p>			
10.	All threaded parts	Look for damaged threads.	
11.	All metal parts	Look for cracks, breaks, and abnormal bends.	
ASSEMBLY			
12.	Adapter (2)	Chain (3)	Place in position.
13.		Linch pin (4)	Push in and latch.
14.		Adapter tube (1)	Push in.
15.	Adapter (2) and adapter tube (1)	Bolt (5) and new locknut (6)	Screw together and tighten using two 9/16-inch open-end wrenches.
INSTALLATION			
16.	Boring head (7)	Adapter tube (1) with assembled parts	Place in position.

HYDRAULIC EARTH DRILL MOUNTING ADAPTER - CONTINUED

LOCATION	ITEM	ACTION REMARKS
17. Adapter tube (7) and boring head (7)	Pin (8)	a. Have assistant aline pin holes of tube (1) and head (7). b. Using 2-pound head ball-peen hammer, tap in.
18. Adapter tube (1) and pin (8)	Two new cotter pins (9)	a. Push in. b. Using multiple tongue and groove slip- joint pliers, bend ends back.

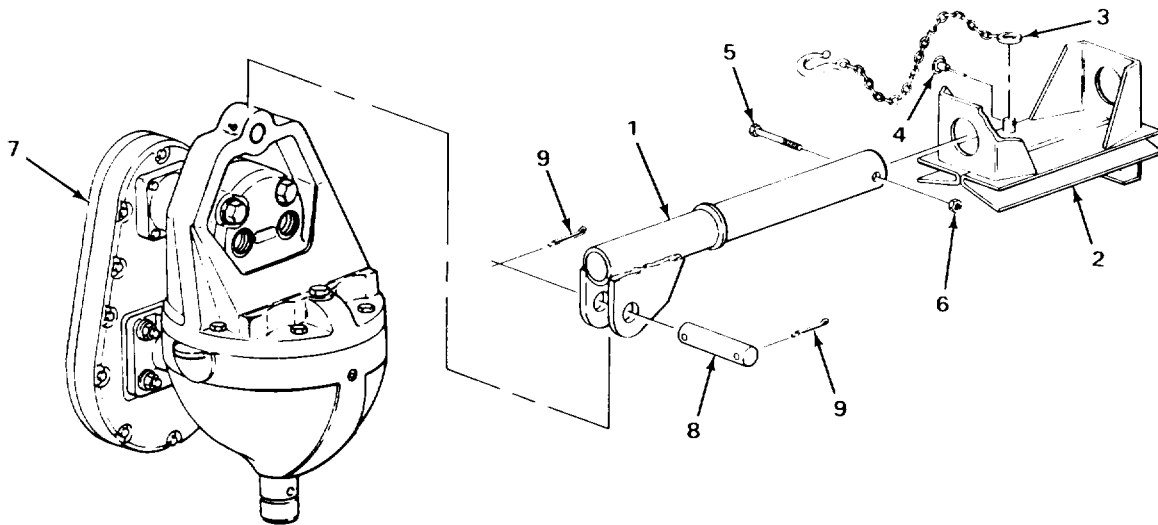

TASK ENDS HERE

TA243630

HYDRAULIC EARTH DRILL AUGER

This task covers:

- a. Removal (page 2-1866)
- b. Cleaning (page 2-1866)
- c. Inspection/Replacement (page 2-1868)
- d. Installation (page 2-1868)

INITIAL SETUP:

Tools

Handle, ratchet, 3/8-inch drive
 Socket, 3/8-inch drive, 3/4-inch
 Wrench, open-end, 3/4-inch

Personnel Required

Two

Equipment Condition

Materials/Parts

Rags, wiping (item 21, Appendix C)
 Solvent, drycleaning
 (item 28, Appendix C)

Hydraulic Earth Auger attachment removed
 (TM 5-2420-222-10)

LOCATION	ITEM	ACTION REMARKS
REMOVAL		
1. Earth auger (1) and boring head (2)	Setscrew (3)	Using 3/4-inch, 3/8-inch drive socket and ratchet handle, unscrew and take out.
2 .	Shear bolt (4) and nut (5)	Using 3/4-inch open-end wrench, 3/4-inch, 3/8-inch drive socket, and ratchet handle, unscrew and take apart.
3. Boring head (2)	Earth auger (1)	With aid of assistant, pull off.

CLEANING

NOTE

For more information on how to clean parts, go to General Maintenance Instructions (page 2-137).

HYDRAULIC EARTH DRILL AUGER - CONTINUED

LOCATION	ITEM	ACTION	REMARKS
----------	------	--------	---------

WARNING

Drycleaning solvent P-D-680 is toxic and flammable. Wear protective goggles and gloves and use only in a well ventilated area. Avoid contact with skin, eyes, and clothes and don't breathe vapors. Do not use near open flame or excessive heat. The flashpoint is 100°F to 138°F (38° to 59°C). If you become dizzy while using cleaning solvent, get fresh air immediately and get medical aid. If contact with eyes is made, wash your eyes with water and get medical aid immediately.

- | | | | |
|----|-----------------|--|--|
| 4. | Earth auger (1) | a. Using clean rags dampened in dry-cleaning solvent, wipe clean.
b. Using clean, dry rags, wipe dry. | |
|----|-----------------|--|--|

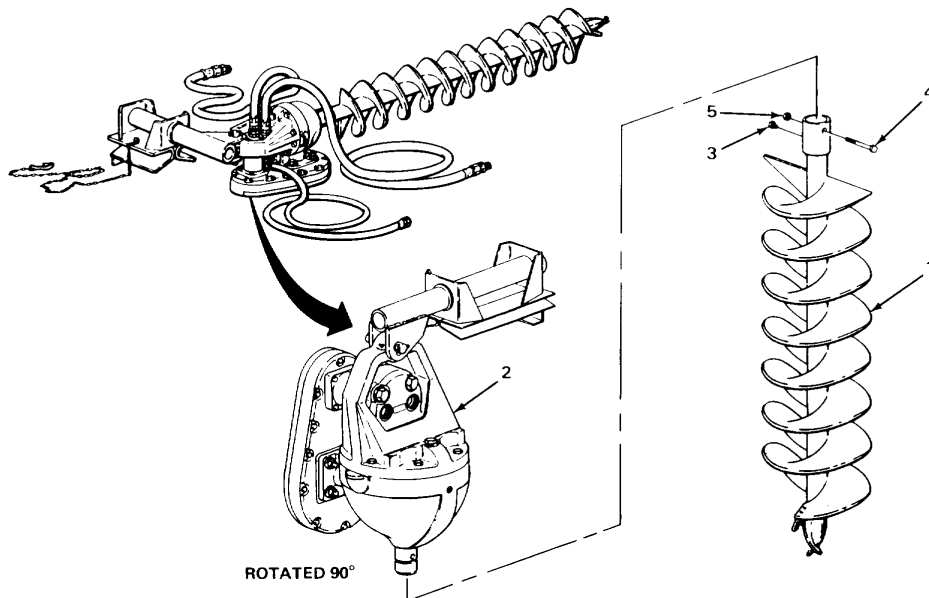

TA243631

HYDRAULIC EARTH DRILL AUGER - CONTINUED

LOCATION	ITEM	ACTION	REMARKS
CLEANING - CONTINUED			
5.	All other parts	a. Clean in drycleaning solvent. b. Using clean, dry rags, wipe dry.	
INSPECTION/REPLACEMENT			
NOTE			
For more information on how to inspect parts, go to General Maintenance Instructions (page 2-137).			
Replace defective parts as needed.			
6.	All threaded parts	Look for damaged threads.	
7.	All metal parts	Look for cracks, breaks, and abnormal bends.	
INSTALLATION			
8. Boring head (1)	Earth Auger (2)	With aid of assistant, place in position.	
9. Boring head (1) and earth auger (2)	Shear bolt (3) and nut (4)	a. Have assistant aline pin holes in auger (2) and head (1). b. Screw together and tighten using 3/4-inch drive socket, and ratchet handle.	
10. Boring head (1) and earth auger (2)	Setscrew (5)	Screw in and tighten using 3/4-inch, 3/8-inch drive socket and ratchet handle.	

HYDRAULIC EARTH DRILL AUGER - CONTINUED

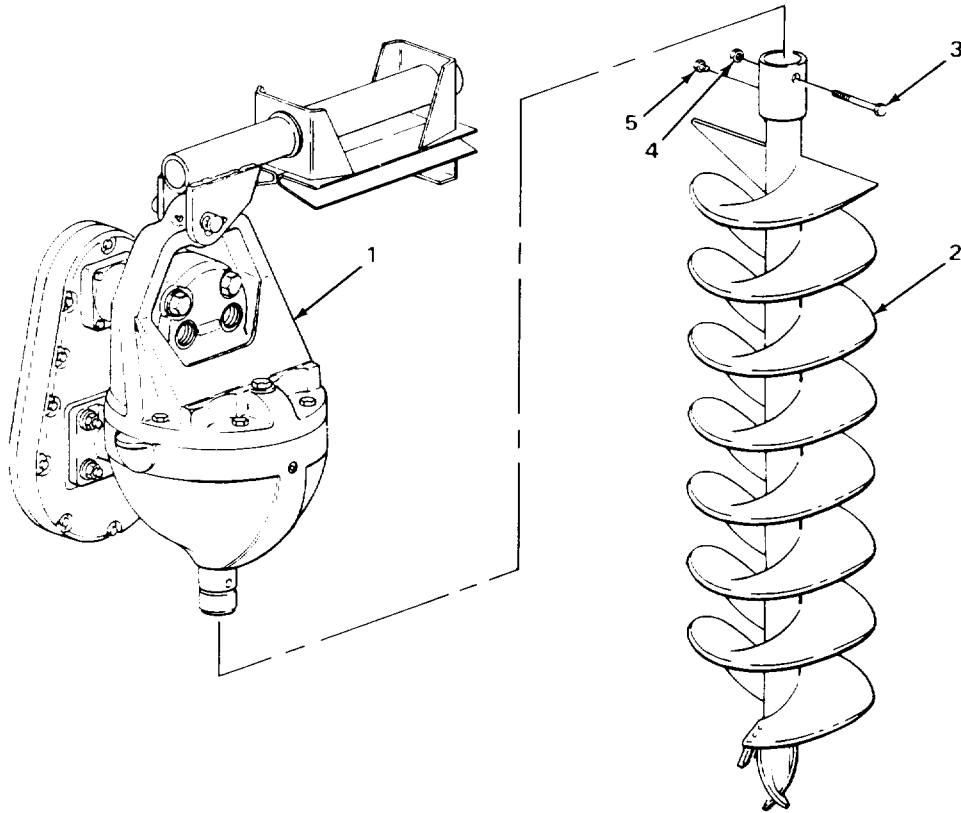

TASK ENDS HERE

TA243632

HYDRAULIC EARTH DRILL BORING HEAD

This task covers:

- | | |
|---------------------------|---|
| a. Draining (page 2-1870) | d. Inspection/Replacement (page 2-1874) |
| b. Removal (page 2-1873) | e. Installation (page 2-1874) |
| c. Cleaning (page 2-1874) | f. Filling (page 2-1875) |

INITIAL SETUP:

Tools

- Container, 10-gallon
- Handle, ratchet, 1/2-inch drive
- Key, socket-head screw, 3/16-inch
- Key, socket-head screw, 5/16-inch
- Lifting equipment, 500-pound capacity
- Socket, 1/2-inch drive, 1 1/8-inch
- Wrench, open-end, 9/16-inch Two
- Wrench, open-end, 11/16-inch
- Wrench, open-end, 3/4-inch
- Wrench, open-end, 7/8-inch
- Wrench, open-end, 1 1/8-inch
- Wrench, open-end, 1 1/2-inch

Materials/Parts

- Fluid, hydraulic (LO 5-2420-222-12)
- Gasket, fill plug (two required)
- Rags, wiping (item 21, Appendix C)
- Solvent, drycleaning (item 28, Appendix C)

Personnel Required

Equipment Condition

- Hydraulic Earth Auger Attachment removed (TM 5-2420-222-10)

LOCATION	ITEM	ACTION	REMARKS
----------	------	--------	---------

DRAINING

NOTE

Hydraulic earth drill boring head does not need to be drained to perform removal.

2-1870

HYDRAULIC EARTH DRILL BORING HEAD - CONTINUED

LOCATION	ITEM	ACTION	REMARKS
----------	------	--------	---------

WARNING

Some parts are heavy. Be careful when handling them. Lifting equipment is needed when parts weigh over 50 pounds (23 kg) for a single person lift, over 100 pounds (45 kg) for a two person lift, and over 150 pounds (68 kg) for a three or more person lift. Do not try to handle heavy parts without lifting equipment. Keep clear of heavy parts supported only by lifting equipment. Failure to observe this precaution could cause serious injury or death of personnel.

1. Hydraulic earth drill auger (1)	Hydraulic earth drill boring head (2) and assembled parts	With aid of assistant, using 500-pound capacity lifting equipment, position with drain plug (3) at lowest point.
------------------------------------	---	--

NOTE

Steps 2 thru 4 will drain the hydraulic earth drill boring head chain case.

2. Chain housing (4)	Fill plug (5) and gasket (6)	a. Using 1 1/8-inch, 1/2-inch drive socket and ratchet handle, unscrew and take out. b. Get rid of gasket (6).
----------------------	------------------------------	---

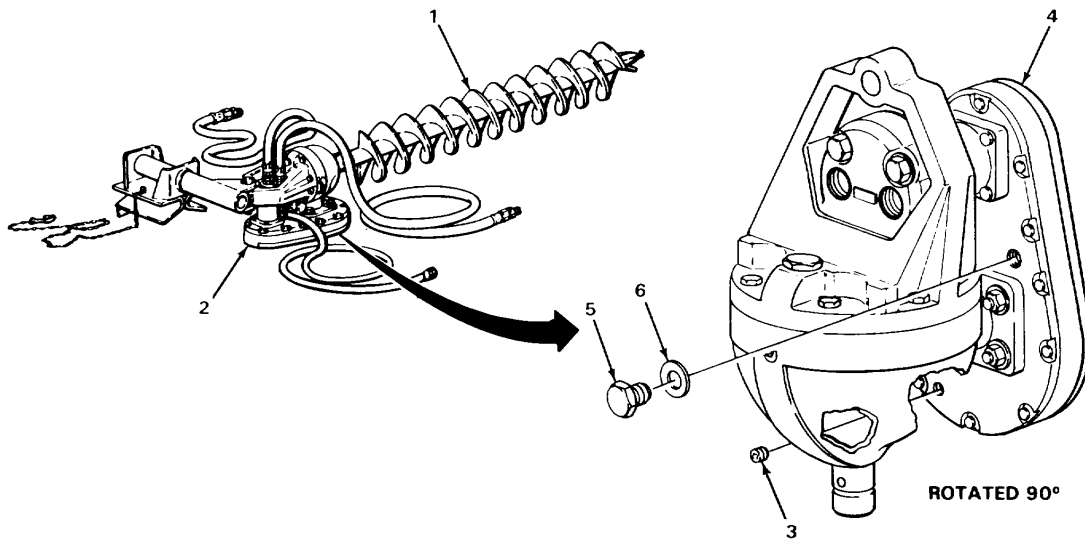

TA243633

HYDRAULIC EARTH DRILL BORING HEAD - CONTINUED

LOCATION	ITEM	ACTION	REMARKS
DRAINING - CONTINUED			
3.	Chain case (1)	Drain plug (2)	<ol style="list-style-type: none"> Place 10-gallon container underneath. Using 3/16-inch socket-head screw key, unscrew and take out. Drain hydraulic fluid into 10-gallon container. Screw in and tighten using 3/16-inch socket-head screw key. Get rid of drained fluid (page 2-137).
4.	New gasket (3) and fill plug (4)		Screw in and tighten using 1 1/8-inch, 1/2-inch drive socket and ratchet handle.
NOTE			
Steps 5 thru 8 drain hydraulic earth drill boring head gear case.			
5.	Hydraulic earth drill auger (5)	Hydraulic earth drill boring head (6) and assembled parts	With aid of assistant, using 500-pound capacity lifting equipment, position with drain plug (7) at lowest point.
6.	Gear case (8)	Fill plug (9) and gasket (10)	<ol style="list-style-type: none"> Using 1 1/8-inch open-end wrench, unscrew and take out. Get rid of gasket (10).
7.		Drain plug (7)	<ol style="list-style-type: none"> Place 10-gallon container underneath. Using 5/16-inch socket-head screw key, unscrew and take out. Drain hydraulic fluid into 10-gallon container. Screw in and tighten using 5/16-inch socket-head screw key. Get rid of drained fluid (page 2-137).
8.		Fill plug (9) and new gasket (10)	Screw in and tighten using 1 1/8-inch open-end wrench.
9.	Hydraulic earth drill auger (5)	Hydraulic earth drill boring head (6) and assembled parts	<ol style="list-style-type: none"> Using 500-pound capacity lifting equipment, set down. Take off 500-pound capacity lifting equipment.

HYDRAULIC EARTH DRILL BORING HEAD - CONTINUED

LOCATION	ITEM	ACTION	REMARKS
REMOVAL			
10	Hydraulic earth auger attachment	Remove (page 2-1855).	
11	Hydraulic earth drill mounting adapter	Remove (page 2-1862).	
12	Hydraulic earth drill auger	Remove (page 2-1866).	

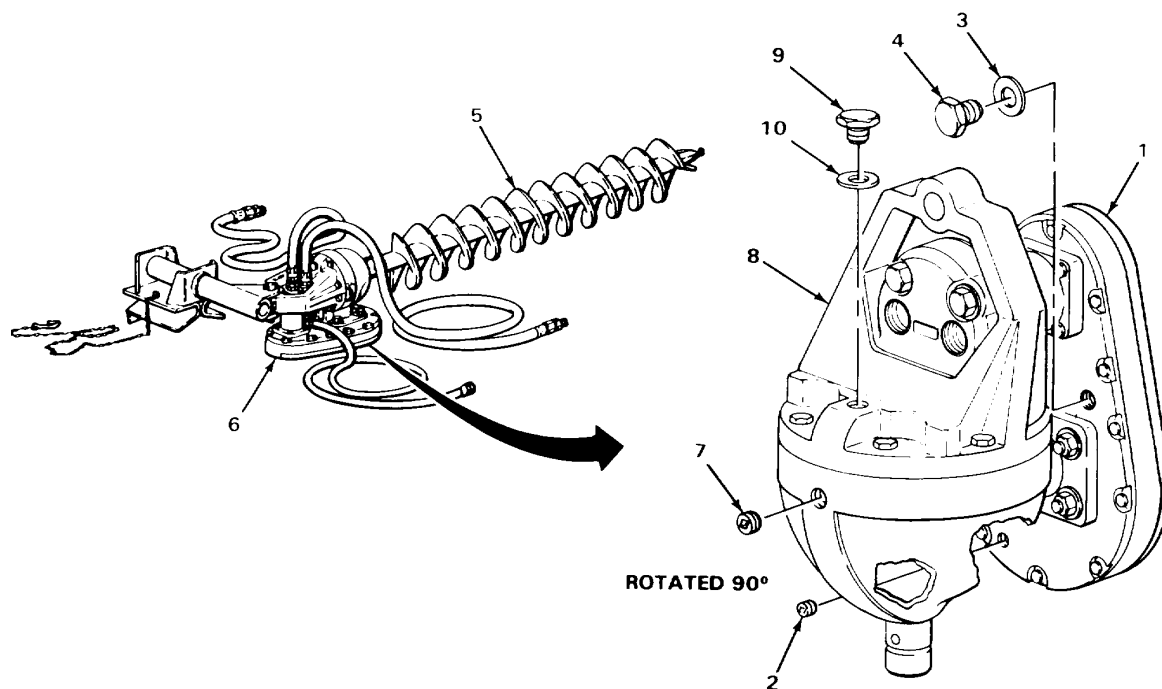

TA243634

HYDRAULIC EARTH DRILL BORING HEAD - CONTINUED

LOCATION	ITEM	ACTION	REMARKS
CLEANING			
NOTE			
For more information on how to clean parts, go to General Maintenance Instructions (page 2-137).			
WARNING			
Drycleaning solvent P-D-680 is toxic and flammable. Wear protective goggles and gloves and use only in a well ventilated area. Avoid contact with skin, eyes, and clothes and don't breathe vapors. Do not use near open flame or excessive heat. The flashpoint is 100°F to 138°F (38° to 59°C). If you become dizzy while using cleaning solvent, get fresh air immediately and get medical aid. If contact with eyes is made, wash your eyes with water and get medical aid immediately.			
13	Hydraulic earth drill boring head (1)	a. Using clean rags dampened in dry-cleaning solvent, wipe clean. b. Using clean, dry rags, wipe dry.	
INSPECTION/REPLACEMENT			
NOTE			
For more information on how to inspect parts, go to General Maintenance Instructions (page 2-137).			
Replace defective parts as needed.			
14	Hydraulic earth drill boring head (1)	Look for cracks, breaks, and abnormal bends.	
INSTALLATION			
15	Hydraulic earth auger attachment	Hydraulic earth drill auger	Install (page 2-1866).
16	Hydraulic earth drill mounting adapter		Install (page 2-1862).
17	Hydraulic earth drill hoses and fittings		Install (page 2-1855).

HYDRAULIC EARTH DRILL BORING HEAD - CONTINUED

LOCATION	ITEM	ACTION	REMARKS
FILLING			
18	Loader backhoe	Hydraulic earth auger attachment	a. Install (TM 5-2420-222-10). b. Operate backhoe controls until auger attachment is in vertical position and auger is resting on ground (TM 5-2420-222-10).
19		Engine	Shut down (TM 5-2420-222-10).

WARNING

Keep clear of hydraulic components when raised and not supported. Sudden loss of hydraulic pressure could cause components to drop without warning.

NOTE

Steps 20 thru 24 fill hydraulic earth drill boring head chain case.

20	Chain housing (2)	Level plug (3)	a. Place 10-gallon container underneath. b. Using 3/16-inch socket-head screw key, unscrew and take out.
----	-------------------	----------------	---

NOTE

If hydraulic fluid comes out level plug hole, skip steps 21 thru 23.

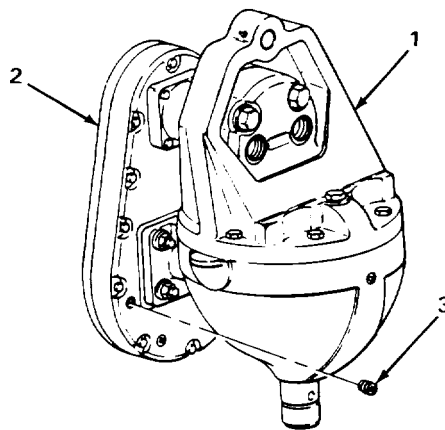

TA243635

HYDRAULIC EARTH DRILL BORING HEAD - CONTINUED

LOCATION	ITEM	ACTION	REMARKS
FILLING - CONTINUED			
21	Chain housing (1)	Fill plug (2) and gasket (3)	<ul style="list-style-type: none"> a. Using 1 1/8-inch, 1/2-inch drive socket and ratchet handle, unscrew and take out. b. If gasket was not replaced during draining, get rid of.
22	Hydraulic earth drill boring head (4)	Chain housing (1)	Add proper grade of hydraulic fluid (LO 5-2420-222-12) until fluid seeps from level plug hole.
NOTE			
If gasket has just been replaced during draining, it may be reused. Otherwise, use new gasket.			
23	Chain housing (1)	Gasket (3) and fill plug (2)	Screw in and tighten using 1 1/8-inch, 1/2-inch drive socket and ratchet handle.
24		Level plug (5)	<ul style="list-style-type: none"> a. Screw in and tighten using 3/16-inch socket-head screw key. b. Get rid of drained fluid (page 2-137).
NOTE			
Steps 25 thru 29 fill hydraulic earth drill boring head gear case.			
25	Gear case (6)	Drain plug (7)	<ul style="list-style-type: none"> a. Place 10-gallon container underneath. b. Using 5/16-inch socket-head screw key, unscrew and take out.
NOTE			
If hydraulic fluid seeps from level plug hole, skip steps 26 thru 28.			
26		Fill plug (8) and gasket (9)	<ul style="list-style-type: none"> a. Using 1 1/8-inch open-end wrench, unscrew and take out. b. If gasket was not replaced during draining, get rid of.
27	Hydraulic earth drill boring head (4)	Gear case (1)	Add proper grade of hydraulic fluid (LO 5-2420-222-12) until fluid seeps from level plug hole.

HYDRAULIC EARTH DRILL BORING HEAD - CONTINUED

LOCATION	ITEM	ACTION	REMARKS
NOTE			
If gasket has just been replaced during draining, it may be reused. Otherwise, use new gasket.			
28	Gear case (6)	Gasket (9) and fill plug (8)	Screw in and tighten using 1 1/8-inch open-end wrench.
29	Drain plug (7)	a. Screw in and tighten using 5/16-inch socket-head screw key. b. Get rid of drained fluid (page 2-137).	
30	Loader backhoe	Hydraulic earth auger attachment	Operate for 5 minutes (TM 5-2420-222-10).

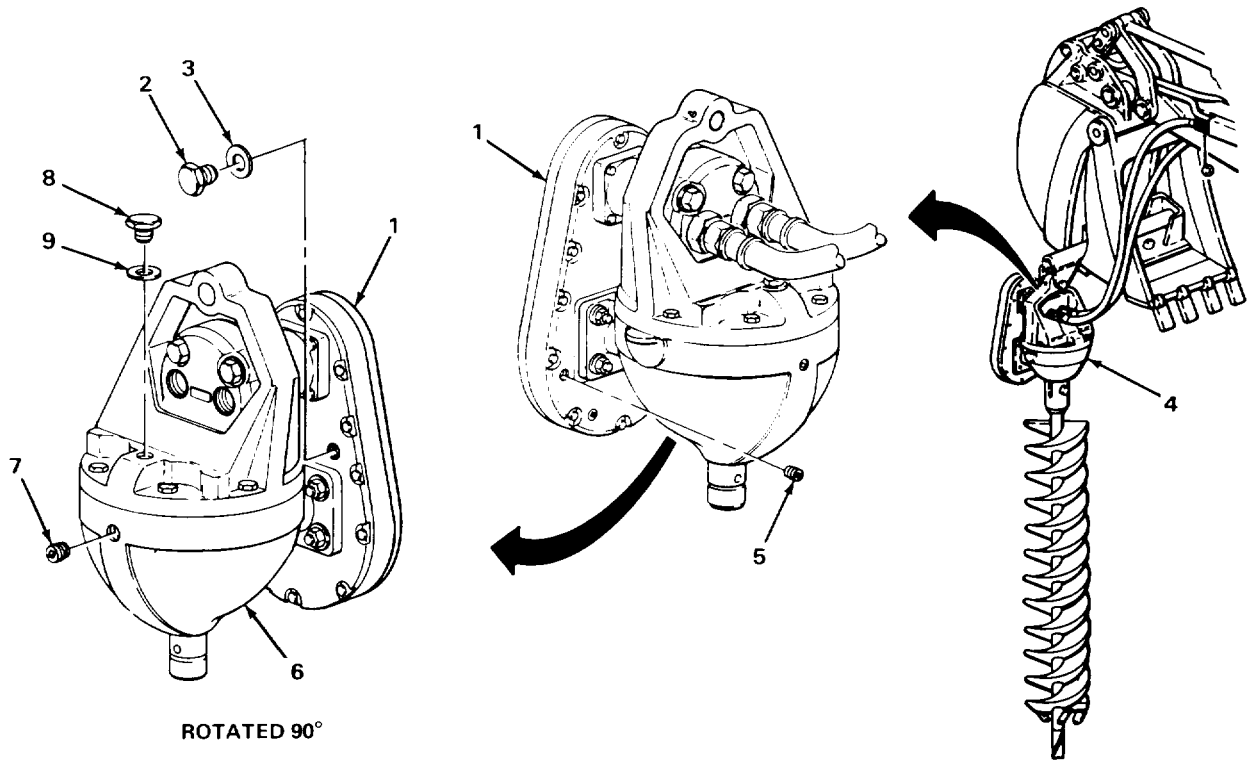

TA243636

HYDRAULIC EARTH DRILL BORING HEAD - CONTINUED

LOCATION	ITEM	ACTION	REMARKS
FILLING - CONTINUED			
WARNING			
Keep clear of hydraulic components when raised and not supported. Sudden loss of hydraulic pressure could cause components to drop without warning.			
31	Loader backhoe	Hydraulic earth drill hoses and fittings	<ul style="list-style-type: none"> a. Check for leaks. b. If leaking, using 9/16-inch, 11/16-inch, 3/4-inch, 7/8-inch, 11/8-inch, or 1 1/2-inch open-end wrench, tighten and repeat steps 30 and 31. c. If leaking does not stop, replace defective parts (page 2-137). d. If leaks were found, fill transmission (page 2-137).
32		Engine	Shut down (TM 5-2420-222-10).
33	Hydraulic earth drill boring head (1)	Gear case (2) and chain housing (3)	<ul style="list-style-type: none"> a. Check for leaks. b. If leaking, using 3/16-inch, 5/16-inch socket-head screw key, or 1 1/8-inch open-end wrench, tighten parts and repeat steps 30, 32, and 33. c. If leaking does not stop, replace defective parts as outlined in this task. d. If leaks were found, repeat steps 20 thru 30 and 32 and 33.
34	Loader backhoe	Hydraulic earth auger attachment	If not to be used, remove (TM 5-2420-222-10).

HYDRAULIC EARTH DRILL BORING HEAD - CONTINUED

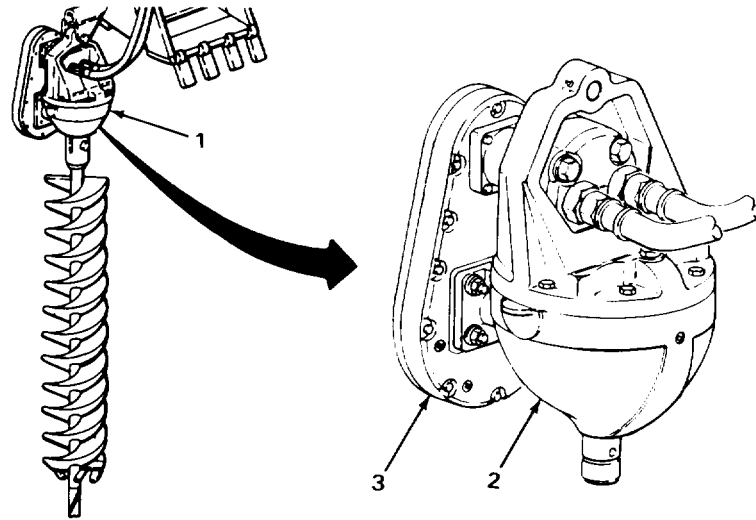

TASK ENDS HERE

HYDRAULIC IMPACTOR LINES AND FITTINGS

This task covers:

- a. Removal (page 2-1880)
- b. Disassembly (page 2-1880)
- c. Cleaning (page 2-1880)
- d. Inspection/Replacement (page 2-1881)
- e. Assembly (page 2-1882)
- f. Installation (page 2-1882)

INITIAL SETUP

Tools

- Container, flexible, 1-gallon
- Knife, pocket
- Wrench, open-end, 1-inch
- Wrench, open-end, 1/8-inch
- Wrench, open-end, 1 1/4-inch (two required)
- Wrench, open-end, 1 1/2-inch

Materials/Parts

- Detergent, GP (item 7, Appendix C)
- Packing, elbow (two required)
- Rags, wiping (item 21, Appendix C)

Materials/Parts - Continued

- Solvent, drycleaning (item 28, Appendix C)
- Tags, marking (item 30, Appendix C)

Personnel Required

One

Equipment Condition

Hydraulic impactor removed (TM 5-2420-222-10)

HYDRAULIC IMPACTOR LINES AND FITTINGS - CONTINUED

LOCATION	ITEM	ACTION REMARKS
REMOVAL		
1. Two elbows (1)	Two hoses (2)	<ul style="list-style-type: none"> a. Tag (page 2-137). b. Place 1-gallon flexible container underneath elbow (1). c. Using 1 1/8-inch and 1 1/4-inch open-end wrenches, unscrew and take out.
2. Two adapters (3)	Two elbows (1)	<ul style="list-style-type: none"> a. Note relative positions for proper placement during installation. b. Using two 1 1/4-inch open-end wrenches, unscrew and take out.
3. Impactor upper housing (4)	Two adapters (3) with assembled packings (5)	<ul style="list-style-type: none"> a. Using 1-inch open-end wrench, unscrew and take out. b. Get rid of drained fluid (page 2-137).
4. Two adapters (3)	Two packings (5)	<ul style="list-style-type: none"> a. Using pocket knife, pry off. b. Get rid of.
DISASSEMBLY		
5. Two hoses (2)	Male quick coupler (6) and female quick coupler (7)	<ul style="list-style-type: none"> a. Tag (page 2-137). b. Using 1 1/8-inch and 1 1/2-inch open-end wrenches, unscrew and take off.
CLEANING		
NOTE		
<p>For more information on how to clean parts, go to General Maintenance Instructions (page 2-137).</p>		
6.	All hoses	<ul style="list-style-type: none"> a. Using clean rags dampened in solution of detergent and water, wipe clean. b. Using clean rags dampened in clean water, rinse. c. Using clean, dry rags, wipe dry.

WARNING

Drycleaning solvent P-D-680 is toxic and flammable. Wear protective goggles and gloves and use only in a well ventilated area. Avoid contact with skin, eyes, and clothes and don't breathe vapors. Do not use near open flame or excessive heat. The flashpoint is 100°F to 138°F (38° to 59°C). If you become dizzy while using cleaning solvent, get fresh air immediately and get medical aid. If contact with eyes is made, wash your eyes with water and get medical aid immediately.

HYDRAULIC IMPACTOR LINES AND FITTINGS - CONTINUED

LOCATION	ITEM	ACTION	REMARKS
7.	All metal parts	a. Clean in drycleaning solvent. b. Using clean, dry rags, wipe dry.	

INSPECTION/REPLACEMENT

NOTE

For more information on how to inspect parts, go to **General Maintenance Instructions** (page 2-137).

Replace defective parts as needed.

- | | | |
|-----|--------------------|-------------------------------------|
| 8. | All hoses | Look for cuts, cracks, and breaks. |
| 9. | All other parts | Look for cracks, breaks, and bends. |
| 10. | All threaded parts | Look for damaged threads. |

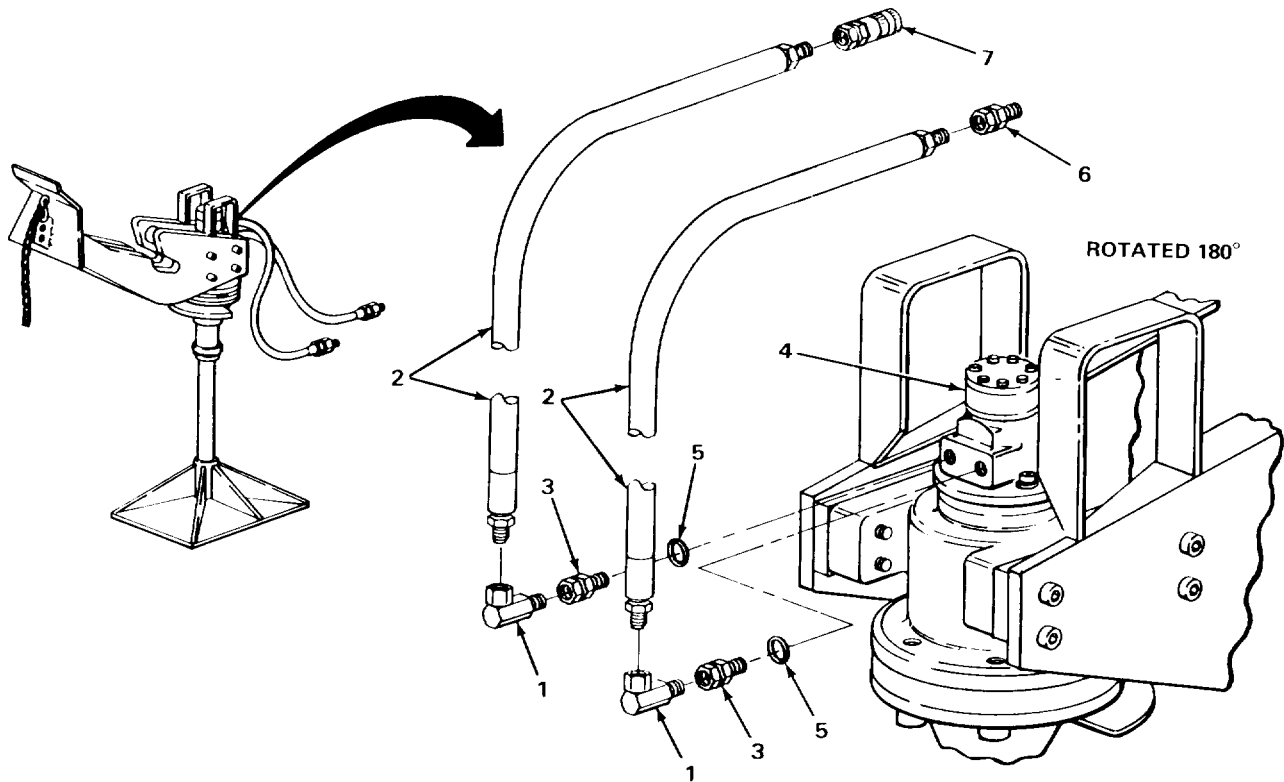

TA243638

HYDRAULIC IMPACTOR LINES AND FITTINGS - CONTINUED

LOCATION	ITEM	ACTION	REMARKS
ASSEMBLY			
11. Two hoses(1)	Male quick coupler (2) and female quick coupler (3)	a. Screw on and tighten using 1 1/8-inch and 1 1/2-inch open-end wrenches. b. Take off tags.	
INSTALLATION			
12. Two adapters (4)	Two new packings (5)	Place in position.	
13. Impactor upper housing (6)	Two adapters (4) with assembled packings (5)	Screw in and tighten using 1-inch open-end wrench.	
14. Two adapters (4)	Two elbows (7)	Screw in and tighten to same relative positions as noted during removal using two 1 1/4-inch open-end wrenches.	
15. Two elbows (7)	Two hoses (1)	a. Screw in and tighten using 1 1/8-inch and 1 1/4-inch open-end wrenches. b. Take off tags.	

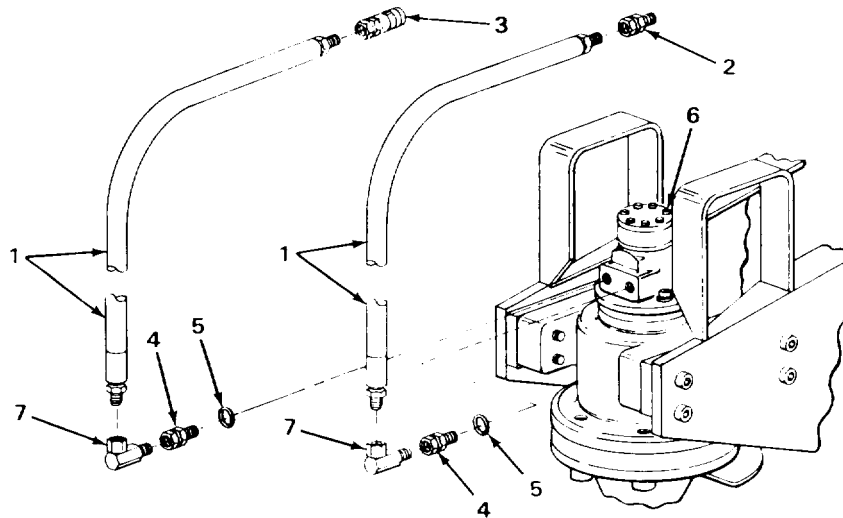

TASK ENDS HERE

TA243639

HYDRAULIC IMPACTOR MOUNTING ADAPTER

This task covers:

- a. Removal (page 2-1884)
 - b. Cleaning (page 2-1884)
 - c. Inspection/Replacement (page 2-1886)
 - d. Installation (page 2-1886)
-

INITIAL SETUP

Tools

Bar, pinch, 36-inch
Bar, pry, 15 to 16-inch
Bit, screwdriver, socket-head screw,
3/4-inch drive, 5/8-inch
Blocks, wood
Handle, hinged, 3/4-inch drive
Key, socket-head screw, 5/8-inch
Lifting equipment, 500-pound
capacity
Wrench, torque, 3/4-inch drive,
0 to 600 foot-pound capacity

Materials/Parts

Rags, wiping (item 21, Appendix C)
Solvent, drycleaning (item 28, Appendix C)

Personnel Required

Two

Equipment Condition

1. Hydraulic impactor removed
(TM 5-2420-222-10)
2. Hydraulic impactor lines and fittings
removed (page 2-1879)

2-1883

HYDRAULIC IMPACTOR MOUNTING ADAPTER - CONTINUED

LOCATION	ITEM	ACTION	REMARKS
REMOVAL			
WARNING			
<p>Some parts are heavy. Be careful when handling them. Lifting equipment is needed when parts weigh over 50 pounds (23 kg) for a single person lift, over 100 pounds (45 kg) for a two person lift, and over 150 pounds (68 kg) for a three or more person lift. Do not try to handle heavy parts without lifting equipment. Keep clear of heavy parts supported only by lifting equipment. Failure to observe this precaution could cause serious injury or death of personnel.</p>			
1. Hydraulic impactor (1)	Mounting adapter (2)	Using 500-pound capacity lifting equipment, position on wood blocks pointing up.	<p>Keep adapter supported with lifting equipment when on blocks to take pressure off mounting screws.</p>
2. Chain (3) and mounting adapter (2)	Linch pin (4)	Unlatch and pull out.	
3. Mounting adapter (2)	Chain (3)	Take out.	
4. Hydraulic impactor (1) and mounting adapter (2)	Eight screws (5)	Using 5/8-inch, 3/4-inch drive socket-head screw screwdriver bit and hinged handle, unscrew and take out.	
5. Hydraulic impactor (1)	Mounting adapter (2)	<ol style="list-style-type: none"> a. Note relative position for proper placement during installation. b. With aid of assistant using 15 to 16-inch pry bar and 500-pound capacity lifting equipment, lift off and set on wood blocks. c. Take off 500-pound capacity lifting equipment. 	

CLEANING

NOTE

For more information on how to clean parts, go to General Maintenance Instructions (page 2-137).

HYDRAULIC IMPACTOR MOUNTING ADAPTER - CONTINUED

LOCATION	ITEM	ACTION	REMARKS
----------	------	--------	---------

WARNING

Drycleaning solvent P-D-680 is toxic and flammable. Wear protective goggles and gloves and use only in a well ventilated area. Avoid contact with skin, eyes, and clothes and don't breathe vapors. Do not use near open flame or excessive heat. The flashpoint is 100°F to 138°F (38° to 59°C). If you become dizzy while using cleaning solvent, get fresh air immediately and get medical aid. If contact with eyes is made, wash your eyes with water and get medical aid immediately.

- | | | |
|-------------------------|-----------------------|--|
| 6. Mounting adapter (2) | | <ul style="list-style-type: none"> a. Using clean rags dampened in dry-cleaning solvent, wipe clean. b. Using clean, dry rags, wipe dry. |
| 7. | All other metal parts | <ul style="list-style-type: none"> a. Clean in drycleaning solvent. b. Using clean, dry rags, wipe dry. |

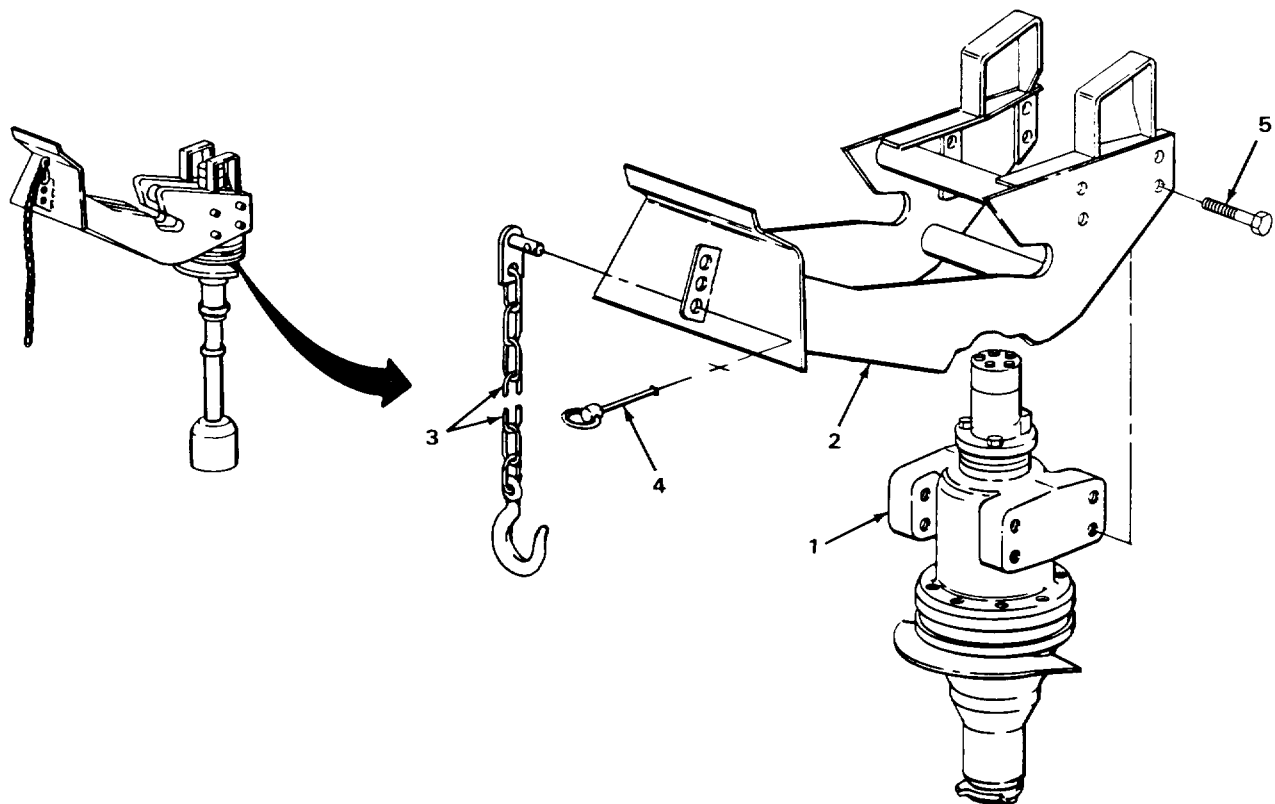

TA243640

HYDRAULIC IMPACTOR MOUNTING ADAPTER - CONTINUED

LOCATION	ITEM	ACTION	REMARKS
INSPECTION/REPLACEMENT			
NOTE			
For more information on how to inspect parts, go to General Maintenance Instructions (page 2-137) .			
Replace defective parts as needed.			
8.	All threaded parts		Look for damaged threads.
9.	All metal parts		Look for cracks, breaks, and abnormal bends.
INSTALLATION			
WARNING			
Some parts are heavy. Be careful when handling them. Lifting equipment is needed when parts weigh over 50 pounds (23 kg) for a single person lift, over 100 pounds (45 kg) for a two person lift, and over 150 pounds (68 kg) for a three or more person lift. Do not try to handle heavy parts without lifting equipment. Keep clear of heavy parts supported only by lifting equipment. Failure to observe this precaution could cause serious injury or death of personnel.			
10.	Hydraulic impactor (1)	Mounting adapter (2)	With assistant using 36-inch pinch bar to align screw holes, using 500-pound capacity lifting equipment, lift into same relative position as noted during removal.
11.	Hydraulic impactor (1) and mounting adapter (2)	Eight screws (3)	<ol style="list-style-type: none"> a. Screw in until snug using 5/8-inch socket-head screw key. b. Using 5/8-inch socket-head screw screwdriver bit and 0 to 600 foot-pound capacity, 3/4-inch drive torque wrench, tighten to 420 foot-pounds (570 N•m) torque. c. Take off 500-pound capacity lifting equipment.
12.	Mounting adapter (2)	Chain (4)	Place in position.

HYDRAULIC IMPACTOR MOUNTING ADAPTER - CONTINUED

LOCATION	ITEM	ACTION	REMARKS
----------	------	--------	---------

13. Chain (4) and mounting adapter (2)

Linch pin (5)

Push in and latch.

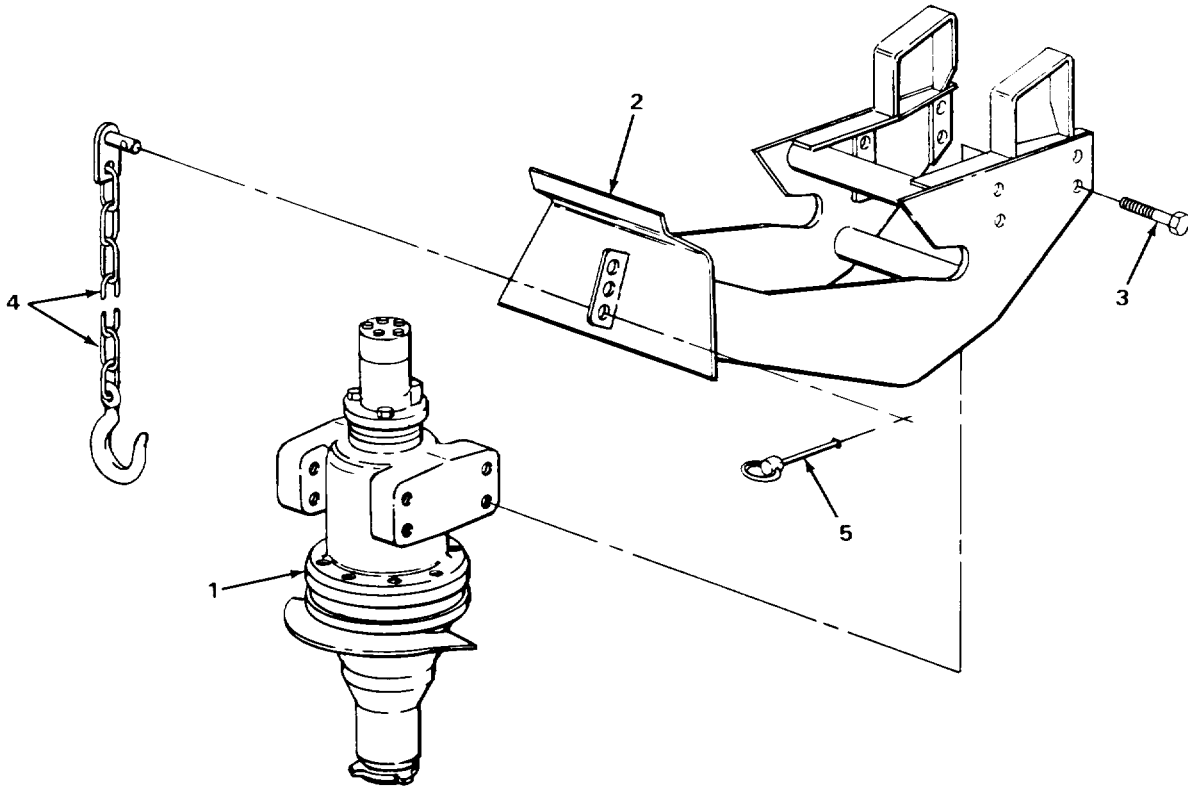

TASK ENDS HERE

TA243641

HYDRAULIC IMPACTOR WORKING TOOLS

This task covers:

- a. Removal (page 2-1888)
 - b. Cleaning (page 2-1890)
 - c. Inspection/Replacement (page 2-1891)
 - d. Repair (page 2-1891)
 - e. Installation (page 2-1892)
-

INITIAL SETUP

Tools

- Blocks, wood
- Drift pin, brass-tipped, 3/4-inch
- File, thread restore
- Hammer, cross-peen, 3-pound head
- Lifting equipment, 500-pound capacity
- Rule, steel, machinist's, 6-inch
- Scribe, machinist's

Materials/parts

- Lubricator, impactor (LO 5-2420-222-12)
- Rags, wiping (item 21, Appendix C)
- Solvent, drycleaning (item 28, Appendix C)

Personnel Required

Two

LOCATION	ITEM	ACTION	REMARKS
----------	------	--------	---------

NOTE

There are seven working tools that can be used with hydraulic impactor. Maintenance is the same for all seven. Tamper is shown.

REMOVAL

NOTE

Steps 1 and 2 only apply when hydraulic impactor is installed on backhoe bucket.

- | | | | |
|----|----------------|----------------|--|
| 1. | Loader backhoe | Backhoe bucket | Using backhoe boom and backhoe bucket control levers, position bucket on ground with impactor pulled in toward loader backhoe in horizontal position (TM 5-2420-222-10). |
| 2. | Engine | | Shut down (TM 5-2420-222-10). |

HYDRAULIC IMPACTOR WORKING TOOLS - CONTINUED

LOCATION	ITEM	ACTION	REMARKS
----------	------	--------	---------

NOTE

Step 3 applies only when hydraulic impactor is not installed on backhoe bucket.

WARNING

Some parts are heavy. Be careful when handling them. Lifting equipment is needed when parts weigh over 50 pounds (23 kg) for a single person lift, over 100 pounds (45 kg) for a two person lift, and over 150 pounds (68 kg) for a three or more person lift. Do not try to handle heavy parts without lifting equipment. Keep clear of heavy parts supported only by lifting equipment. Failure to observe this precaution could cause serious injury or death of personnel.

- | | | |
|---------------|------------------------|---|
| 3. Tamper (1) | Hydraulic impactor (2) | <ul style="list-style-type: none"> a. Using 500-pound capacity lifting equipment, lift and place on wood blocks in horizontal position. b. Take off 500-pound capacity lifting equipment. |
|---------------|------------------------|---|

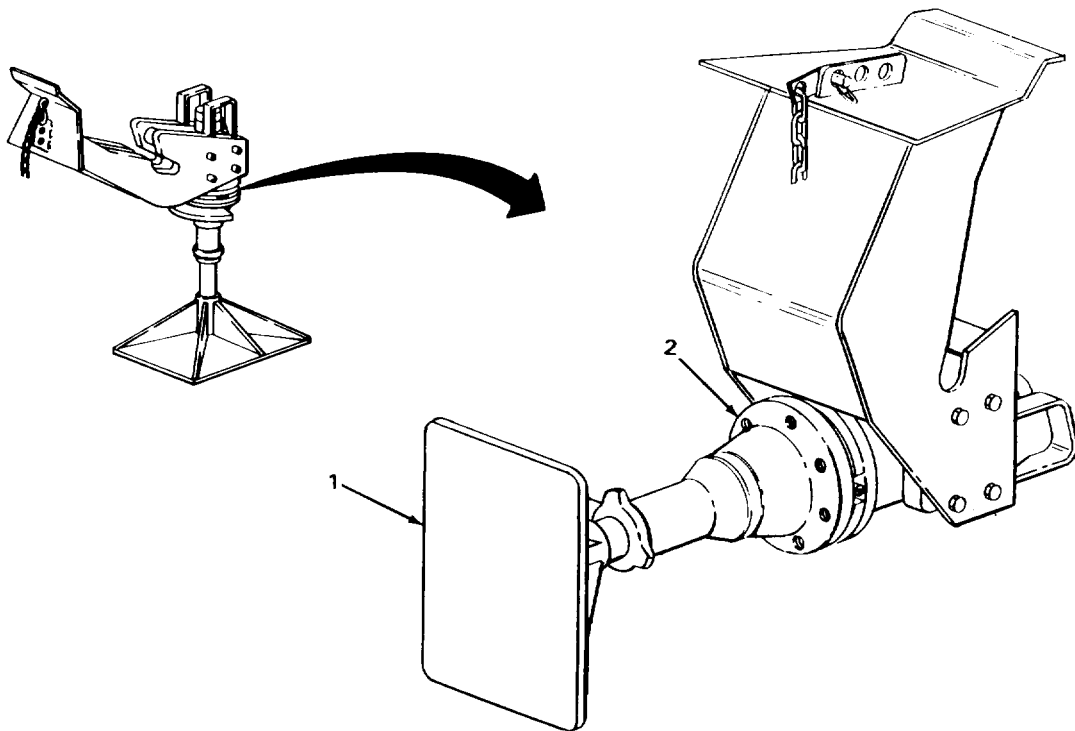

TA243642A

HYDRAULIC IMPACTOR WORKING TOOLS - CONTINUED

LOCATION	ITEM	ACTION	REMARKS
REMOVAL - CONTINUED			
4.	Lower housing (1) and tamper (2)	Tool retainer (3)	a. Using 3/4-inch brass-tipped drift pin and 3-pound head cross-peen hammer, loosen. b. Unscrew out of housing (1).
5.	Lower housing (1)	Tamper (2) with assembled tool retainer (3) and two tool guide set sleeves (4)	With help of assistant, slide out.
6.		Tool guide set ring (5) and tool guide set bushing (6)	Take out.
7.	Tamper (2)	Two tool guide set sleeves (4) and tool retainer (3)	Take off.

CLEANING

NOTE

For more information on how to clean parts, go to General Maintenance Instructions (page 2-137).

WARNING

Drycleaning solvent P-D-680 is toxic and flammable. Wear protective goggles and gloves and use only in a well ventilated area. Avoid contact with skin, eyes, and clothes and don't breathe vapors. Do not use near open flame or excessive heat. The flashpoint is 100°F to 138°F (38° to 59°C). If you become dizzy while using cleaning solvent, get fresh air immediately and get medical aid. If contact with eyes is made, wash your eyes with water and get medical aid immediately.

8.		Tamper (2)	a. Using clean rags dampened with dry-cleaning solvent, wipe clean. b. Using clean, dry rags, wipe dry.
9.		All other metal parts	a. Clean in drycleaning solvent. b. Using clean, dry rag, wipe dry.

HYDRAULIC IMPACTOR WORKING TOOLS - CONTINUED

LOCATION	ITEM	ACTION	REMARKS
----------	------	--------	---------

INSPECTION/REPLACEMENT

NOTE

For more information on how to inspect parts, go to General Maintenance Instructions (page 2-137).

Replace defective parts which cannot be repaired.

- | | | |
|-----|--------------------|--|
| 10. | All metal parts | Look for cracks, breaks, and abnormal bends. |
| 11. | All threaded parts | Look for damaged threads. |

REPAIR

- | | | |
|-----|-------------------|--|
| 12. | Tool retainer (3) | If threads are damaged, using thread restorer file, restore threads. |
|-----|-------------------|--|

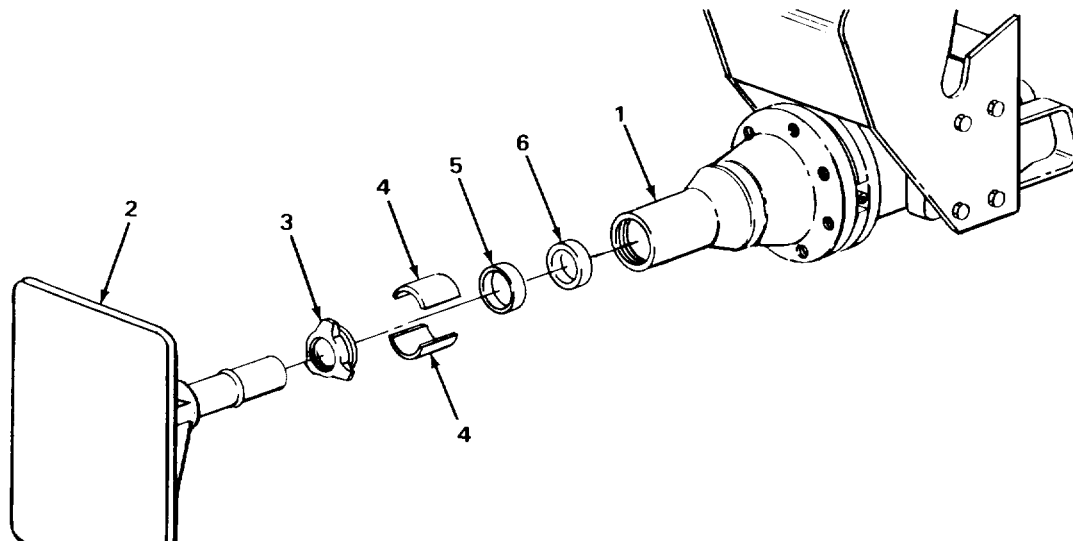

TA243642B

HYDRAULIC IMPACTOR WORKING TOOLS - CONTINUED

LOCATION	ITEM	ACTION	REMARKS
INSTALLATION			
13. Tamper (1)	Tool retainer (2), two tool guide set sleeves (3), tool guide set ring (4), and tool guide set bushing (5)	Place in position.	
CAUTION			
Threads on tool retainer and lower housing must be clean or they may screw together improperly causing damage to parts.			
14. Lower housing (6)	Tamper (1) with assembled tool retainer (2) and two tool guide set sleeves (3), tool guide set ring (4), and tool guide set bushing (5)	<ul style="list-style-type: none"> a. Lubricate lower housing threads and tool retainer threads with impactor lubricant (LO 5-2420-222-12). b. With help of assistant, slide in as far as they will go. 	
CAUTION			
Tool retainer must be tightened properly or parts may be damaged during operation.			
15. Tool retainer (2)		<ul style="list-style-type: none"> a. Screw in until snug. b. Using machinist's scribe, matchmark housing (6) and retainer (2). c. Using 6-inch machinist's steel rule, 3/4-inch brass-tipped drift-pin, and 3-pound head cross-peen hammer, tighten at least 5/8-inch past snug. If tool retainer loosens repeatedly during use, tighten more than 5/8-inch. 	

HYDRAULIC IMPACTOR WORKING TOOLS - CONTINUED

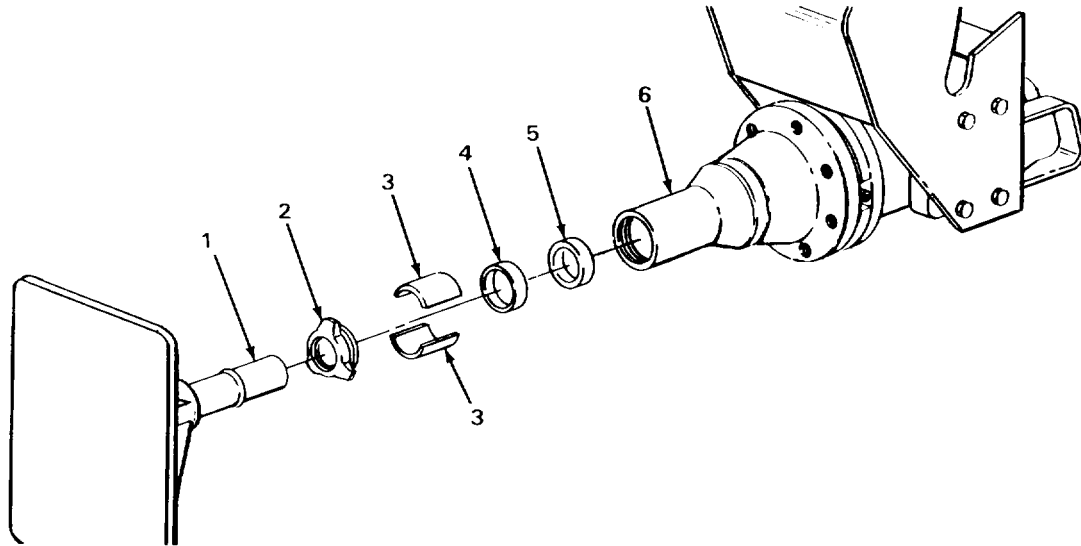

TASK ENDS HERE

HYDRAULIC IMPACTOR AND MOTOR ASSEMBLY

This task covers:

- | | |
|--|--|
| <ul style="list-style-type: none"> a Removal (page 2-1894) b. Cleaning (page 2-1894) | <ul style="list-style-type: none"> c Inspection/Replacement (page 2-1894) d Installation (page 2-1895) |
|--|--|
-

INITIAL SETUP

Materials/Parts

- Rags, wiping (item 21, Appendix C)
- Solvent, drycleaning (item 28, Appendix C)

Personnel Required

One

Equipment Condition

1. Hydraulic impactor removed (TM 5-2420-222-10)
2. Hydraulic impactor lines and fittings removed (page 2-1879)
3. Hydraulic impactor mounting adaptor removed (page 2-1883)
4. Hydraulic impactor working tools removed (page 2-1888)

TA243643

HYDRAULIC IMPACTOR AND MOTOR ASSEMBLY - CONTINUED

LOCATION	ITEM	ACTION	REMARKS
----------	------	--------	---------

REMOVAL

- | | | | |
|----------------------|---|--------------------|--|
| 1. Lower housing (1) | Tool guide set bushing (2), tool guide set ring (3), and two tool guide set sleeves (4) | Place in position. | |
|----------------------|---|--------------------|--|

CAUTION

Threads on tool retainer and lower housing must be clean or they may screw together improperly causing damage to parts.

- | | | | |
|----|-------------------|-----------------------|--|
| 2. | Tool retainer (5) | Screw in and tighten. | |
|----|-------------------|-----------------------|--|

CLEANING

NOTE

For more information on how to clean parts, go to General Maintenance Instructions (page 2-137).

WARNING

Drycleaning solvent P-D-680 is toxic and flammable. Wear protective goggles and gloves and use only in a well ventilated area. Avoid contact with skin, eyes, and clothes and don't breathe vapors. Do not use near open flame or excessive heat. The flashpoint is 100°F to 138°F (38° to 59°C). If you become dizzy while using cleaning solvent, get fresh air immediately and get medical aid. If contact with eyes is made, wash your eyes with water and get medical aid immediately.

- | | | | |
|----|---|--|--|
| 3. | Hydraulic impactor and motor assembly (6) | a. Using clean rags dampened in dry-cleaning solvent, wipe clean.
b. Using clean, dry rags, wipe dry. | |
|----|---|--|--|

INSPECTION/REPLACEMENT

NOTE

For more information on how to inspect parts, go to General Maintenance Instructions (page 2-137).

Replace defective parts as needed. If hydraulic impactor and motor assembly is to be shipped, be sure to include tool guide set and tool retainer.

HYDRAULIC IMPACTOR AND MOTOR ASSEMBLY - CONTINUED

LOCATION	ITEM	ACTION	REMARKS
4.	Hydraulic impactor and motor assembly (6)	Look for cracks, breaks, and abnormal bends.	

INSTALLATION

5. Lower housing (1)	Tool retainer (3)	Unscrew and take out.
----------------------	-------------------	-----------------------

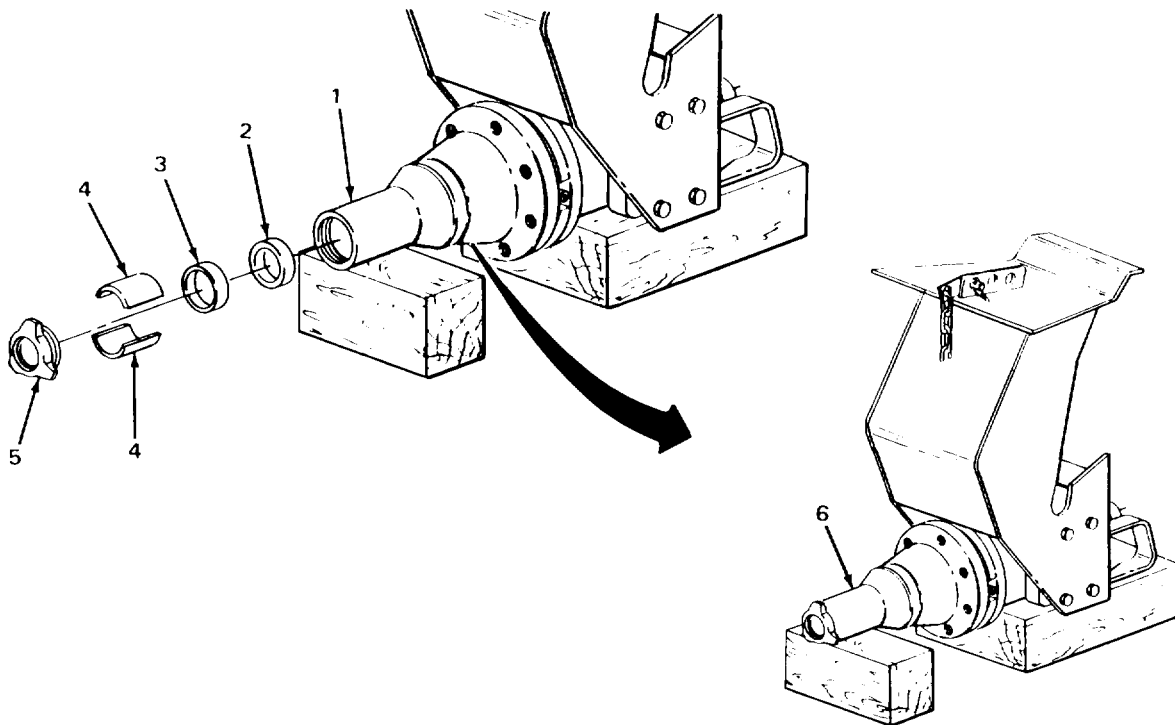

TA243644

HYDRAULIC IMPACTOR AND MOTOR ASSEMBLY - CONTINUED

LOCATION	ITEM	ACTION	REMARKS
----------	------	--------	---------

INSTALLATION - CONTINUED

6. Lower housing (1)	Two tool guide set sleeves (2), tool guide set ring (3), and tool guide set bushing (4)	Take out.	
----------------------	---	-----------	--

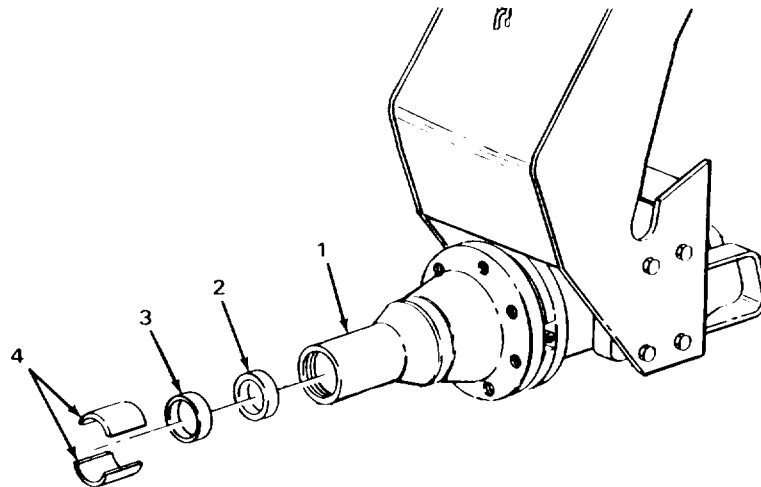

NOTE

FOLLOW-ON MAINTENANCE:

1. Install hydraulic impactor working tools (page 2-1888).
2. Install hydraulic impactor mounting adaptor (page 2-1883).
3. Install hydraulic impactor lines and fittings (page 2-1879).

TASK ENDS HERE

TA243645

Section XXV. PREPARATION FOR STORAGE OR SHIPMENT

	Page		Page
Administrative Storage of Army Materiel	2-1897	Loader Bucket Lever Indicator Lubrication.....	2-1897

ADMINISTRATIVE STORAGE OF ARMY MATERIEL

This task covers:

Administrative Storage (page 2-1897)

ADMINISTRATIVE STORAGE

NOTE

Refer to TM 740-90-1 for instructions on the administrative storage of Army Materiel.

TASK ENDS HERE

LOADER BUCKET LEVEL INDICATOR LUBRICATION

This task covers:

Lubrication (page 2-1898)

INITIAL SETUP

Materials/Parts

Oil, engine (LO 52420-222-12)
Rags, wiping (item 21, Appendix C)

Personnel Required

One

2-1897

LOADER BUCKET LEVEL INDICATOR LUBRICATION - CONTINUED

LOCATION	ITEM	ACTION	REMARKS
----------	------	--------	---------

LUBRICATION

Level indicator (1)

Indicator rod (2)

- a. Apply engine oil between level indicator (1) and indicator rod (2).
Allow enough time for oil to penetrate and run down length of indicator rod.
- b. Using clean dry rags, wipe off any excess oil.
- c. If protective paint has worn off of indicator rod (2), lightly oil exposed areas.

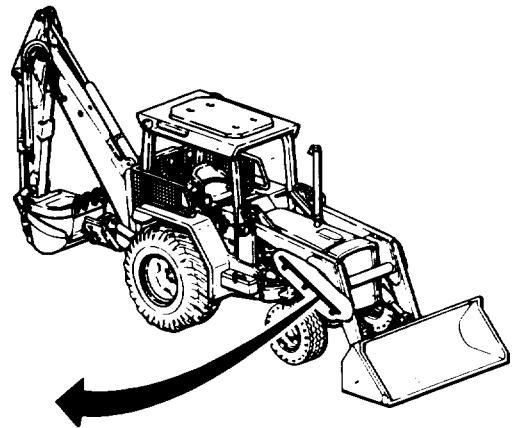
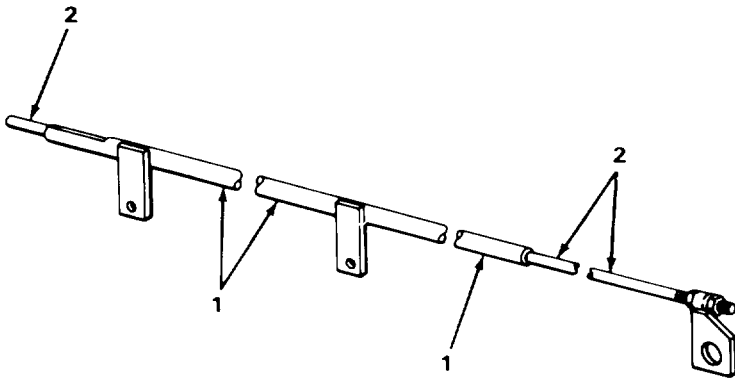

TASK ENDS HERE

TA243646

APPENDIX A

REFERENCES

	Page		Page
Forms	A-1	Scope	A-1
Miscellaneous Publications	A-2	Technical Bulletins	A-2
Publication Indexes	A-1	Technical Manuals	A-1

SCOPE

This appendix lists all forms, field manuals, technical manuals, and miscellaneous publications referenced in this manual.

PUBLICATION INDEXES

The following indexes should be consulted frequently for latest changes or revisions and for new publications relating to material covered in this technical manual.

Consolidated Index of Army Publications and Blank Forms.....	DA Pam 310-1
US Army Equipment Index of Modification Work Orders	DA Pam 750-10

FORMS

Refer to DA Pam 738-750, The Army Maintenance Management System (TAMMS), for instructions on the use of maintenance forms pertaining to this equipment.

TECHNICAL MANUALS

Organizational Maintenance Repair Parts and Special Tools	
List for Loader Backhoe	TM 52420-222-20P
Operator's Manual for Loader Backhoe	TM 5-2420-222-10
Inspection, Care, and Maintenance of Antifriction Bearings.....	TM 9214
Operator's Manual for Welding Theory and Application	TM 9-237
Materials Used for Cleaning, Preserving, Abrading, and Cementing Ordnance Materiel and Related Items Including Chemicals	TM 9-247
Operator's, Unit, Direct Support, and General Support Maintenance Manual for Care, Maintenance, and Repair and Inspection of Pneumatic Tires and Inner Tubes	TM 9-2610-200-14
Operator's, Unit, Intermediate Direct Support, and Intermediate General Support Maintenance Manual for Lead-Acid Storage Batteries	TM 9-6140-200-14
Administrative Storage of Equipment.....	TM 740-90-1
Procedures for Destruction of Equipment to Prevent Enemy Use	TM 750-244-3
Cooling Systems: Tactical Vehicles	TM 750-254

TECHNICAL BULLETINS

Hand Portable Fire Extinguishers for Army Users.....	TB 5-4200-200-10
Equipment Improvement Report and Maintenance Digest:	
Construction Equipment	TB 43-0001-39 Series
Elimination of Combustibles from Interiors of Metal or Plastic	
Gasoline and Diesel Fuel Tanks	TB 750-1047

MISCELLANEOUS PUBLICATIONS

First Aid for Soldiers	FM 21-11
Lubrication Order for Loader Backhoe	LO 52420-222-12

Change 1 A-2

APPENDIX B

MAINTENANCE ALLOCATION CHART

		Page
Section I	Introduction	B-1
Section II	Maintenance Allocation Chart.....	B-4
Section III	Tool and Test Equipment Requirements	B-23
Section IV	Remarks	B-25

Section I. INTRODUCTION

		Page			Page
Explanation of Columns in.....			Explanation of Columns in		
Remarks, Section IV.....	B-3		Tool and Test Equipment		
Explanation of Columns in.....			Requirements, Section III	B-3	
the MAC, Section II.....	B-2		General	B-1	
.....			Maintenance Functions	B-1	

GENERAL

This section provides a general explanation of all maintenance and repair functions authorized at the various maintenance levels.

The Maintenance Allocation Chart (MAC) in Section II designates overall authority and responsibility for the performance of maintenance functions on the identified end item or component. The application of the maintenance functions to the end item or component will be consistent with the capacities and capabilities of the designated maintenance levels.

Section III lists the tools and test equipment (both special tools and common tool sets) required for each maintenance function as referenced from Section II.

Section IV contains supplemental instructions and explanatory notes for a particular maintenance function.

MAINTENANCE FUNCTIONS

Maintenance functions will be limited to and defined as follows:

Inspect. To determine the serviceability of an item by comparing its physical, mechanical, and/or electrical characteristics with established standards through examination (e.g., by sight, sound, or feel).

Test. To verify serviceability by measuring the mechanical, pneumatic, hydraulic, or electrical characteristics of an item and comparing those characteristics with prescribed standards.

Service. Operations required periodically to keep an item in proper operating condition, i.e., to clean (includes decontaminate, when required), to preserve, to drain, to paint, or to replenish fuel, lubricants, chemical fluids, or gases.

Adjust. To maintain or regulate, within prescribed limits, by bringing into proper or exact position, or by setting the operating characteristics to specified parameters.

Aline. To adjust specified variable elements of an item to bring about optimum or desired performance.

MAINTENANCE FUNCTIONS - Continued

Calibrate. To determine and cause corrections to be made or to be adjusted on instruments or test, measuring, and diagnostic equipments used in precision measurement. Consists of comparisons of two instruments, one of which is a certified standard of known accuracy, to detect and adjust any discrepancy in the accuracy of the instrument being compared.

Remove/Install. To remove and install the same item when required to perform service or other maintenance functions. Install may be the act of emplacing, seating, or fixing into position a spare, repair part, or module (component or assembly) in a manner to allow the proper functioning of an equipment or system.

Replace. To remove an unserviceable item and install a serviceable counterpart in its place. "Replace" is authorized by the MAC and is shown as the third position of the SMR code.

Repair. The application of maintenance services, including fault location/troubleshooting, removal/installation, and disassembly/assembly procedures and maintenance actions to identify troubles and restore serviceability to an item by correcting specific damage, fault, malfunction, or failure in a part, subassembly, module (component or assembly), end item, or system.

Overhaul. That maintenance effort (service/action) prescribed to restore an item to a completely serviceable/operational condition as required by maintenance standards in appropriate technical publications (i.e., DMWR). Overhaul is normally the highest degree of maintenance performed by the Army. Overhaul does not normally return an item to like new condition.

Rebuild. Consists of those services/actions necessary for the restoration of unserviceable equipment to a like new condition in accordance with original manufacturing standards. Rebuild is the highest degree of materiel maintenance applied to Army equipment. The rebuild operation includes the act of returning to zero those age measurements (hours/miles, etc.) considered in classifying Army equipment/components.

EXPLANATION OF COLUMNS IN THE MAC, SECTION II

Column 1, Group Number. Column 1 lists functional group code numbers, the purpose of which is to identify maintenance significant components, assemblies, subassemblies, and modules with the next higher assembly. End item group number shall be "00." **Column 2, Component/Assembly.** Column 2 contains the names of components, assemblies, subassemblies, and modules for which maintenance is authorized.

Column 3, Maintenance Function. Column 3 lists the functions to be performed on the item listed in Column 2. (For a detailed explanation of these functions, refer to Maintenance Functions, page B-1.) **Column 4, Maintenance Level.** Column 4 specifies, by the listing of a work time figure in the appropriate subcolumn(s), the level of maintenance authorized to perform the function listed in Column 3. This figure represents the active time required to perform that maintenance function at the indicated level of maintenance. If the number or complexity of the tasks within the listed maintenance function vary at different maintenance levels, appropriate work time figures will be shown for each level. The work time figure represents the average time required to restore an item (assembly, subassembly, component, module, end item, or system) to a serviceable condition under typical field operating conditions. This time includes preparation time (including any necessary disassembly/assembly time), troubleshooting/fault location time, and quality assurance/quality control time in addition to the time required to perform the specific tasks identified for the maintenance functions authorized in the Maintenance Allocation Chart. The symbol designations for the various maintenance levels are as follows:

C..... Unit (Operator or Crew)
O Unit (Organizational) Maintenance
F Direct Support Maintenance
H..... General Support Maintenance
D..... Depot Maintenance

Column 5, Tools and Equipment. Column 5 specifies, by code, those common tool sets (not individual tools) and special tools, TMDE, and support equipment required to perform the designated function.

EXPLANATION OF COLUMNS IN THE MAC, SECTION II - Continued

Column 6, Remarks. This column shall, when applicable, contain a letter code, in alphabetic order, which shall be keyed to the remarks contained in Section IV.

EXPLANATION OF COLUMNS IN TOOL AND TEST EQUIPMENT REQUIREMENTS, SECTION III

Column 1, Tool or Test Equipment Reference Code. The tool and test equipment reference code correlates with a code used in the MAC, Section II, Column 5.

Column 2, Maintenance Level. The lowest level of maintenance authorized to use the tool or test equipment.

Column 3, Nomenclature. Name or identification of the tool or test equipment.

Column 4, National/NATO Stock Number. The National or NATO Stock Number of the tool or test equipment.

Column 5, Tool Number. The manufacturer's part number.

EXPLANATION OF COLUMNS IN REMARKS, SECTION IV

Column 1, Reference Code. The code recorded in Column 6, Section II.

Column 2, Remarks. This column lists information pertinent to the maintenance function being performed as indicated in the MAC, Section II.

SECTION II. MAINTENANCE ALLOCATION CHART

(1) Group Number	(2) Component/Assembly	(3) Maintenance Function	(4) Maintenance Level					(5) Tools and Equipment	(6) Remarks
			UNIT		DS	GS	DEPOT		
			C	O	F	H	D		
01	ENGINE								
0100	Engine Assembly	Inspect Test Service Replace Repair	0.8 0.6	 0.8	 2.5 10.0	 20.1	 3,5,15 1-3 3,8,15,18 3,15,18		
0101	<i>Crankcase, Block, Cylinder Head</i> Engine Block Assembly	Inspect Replace Repair			0.8 1.0	 21.0 4.0	3,15 3,15 3,15		
	Cylinder Sleeves	Inspect Replace Repair			1.0 12.0	2.0	3,15 3,15 3,15		
	Diesel Cylinder Head	Replace Repair			4.3	6.0	3,15 3,15		
	Cylinder Block Plate	Replace				2.0	3,15		
0102	<i>Crankshaft</i> Engine Crankshaft	Inspect Replace				1.0 13.0	15 3,15		
	Sleeve Bearings	Inspect Replace				0.8 4.5	15 3,15		
	Pulley	Replace				1.8	3,15		
	Front Oil Seal	Replace				7.0	3,15		
0103	<i>Flywheel Assembly</i> Engine Flywheel and Ring Gear	Inspect Replace Repair			1.0 5.0 5.2		3,15 3,15 3,15		
	Flywheel Housing	Replace			2.0		3,15		
0104	<i>Pistons and Connecting Rods</i> Pistons, Pins, Rings, and Connecting Rods	Inspect Replace Repair				3.0 1.0 1.0	15 3,15 3,15		
	Connecting Rod Bearing	Replace				4.0	3,15		

(1) Group Number	(2) Component/Assembly	(3) Maintenance Function	(4) Maintenance Level					(5) Tools and Equipment	(6) Remarks	
			UNIT		DS	GS	DEPOT			
			C	O	F	H	D			
0105	<i>Valves, Camshafts, and Timing System</i> Valves	Adjust		1.5					1-3	
		Replace				6.0			3,15	
		Repair				2.0			3,15	
	Rocker Arm Assembly, Push Rods and Tappets	Inspect		1.0					3	
		Repair					2.5		3,15	
		Replace				1.0			3,15	
	Timing Gear Cover	Repair					7.0		3,15	
		Replace							3,15	
	Idler Gear	Replace						2.0	3,15	
		Camshaft						2.5	3,15	
	Rocker Arm Cover	Replace		0.6					3	
	Control Cams, Gears, and Bushings	Replace						12.0	3,15	
		Repair						5.0	3,15	
0106	<i>Engine Lubrication System</i> Lubricating Cooler	Replace		1.0					3	
		Repair		1.0					1-3	
	Filler Neck	Replace		1.0					3	
		Repair		0.2					3	
	Oil Filler Cap	Replace		0.1						
	Oil Pump Assembly	Replace					2.5		3,15	
		Repair					3.0		3,15	
	Oil Filter Element	Replace		0.5					3	
		Rod Liquid Level Gage	Inspect	0.1						
	Pressure Regulating Valve	Replace		1.0				1.0	3,15	
		Adjust						1.5	3,15	
	Hoses, Pipes, Fittings	Replace		1.0					1-3	
	Oil Pan	Replace					2.0		3	
0108	<i>Manifolds</i> Exhaust Manifold and Gasket	Inspect		0.3						
		Replace		1.0					3	

(1) Group Number	(2) Component/Assembly	(3) Maintenance Function	(4) Maintenance Level					(5) Tools and Equipment	(6) Remarks
			UNIT		DS	GS	DEPOT		
			C	O	F	H	D		
02	CLUTCH								
0200	<i>Clutch Assembly</i> Clutch Pressure Plate, Disk, Carrier, and Bearing Clutch Manual Control Lever Clutch Bearing Carrier Support	Replace Repair Repair Repair			6.0 6.5 6.5 6.5			3,15,20,26 3,13,15,19 3,15,20 3,15,20	
0202	<i>Clutch Release Mechanism</i> Clutch Pedal Linkage Clutch Pedal Inspect	Inspect Adjust Replace Repair Inspect Replace Repair		0.2 0.5 0.5 1.0 0.2 2.0 0.5				3 3 3 3 3 3 3	
03	FUEL SYSTEM								
0301	<i>Carburetor, Fuel Injector</i> Fuel Injection Nozzles Test Fuel Injector Tubes and Fittings	Replace Repair Replace Repair		1.4 1.4 1.4		1.8 3.6		22 3 3,15,21,22 3 1-3	
0302	<i>Fuel Pumps</i> Fuel Metering Pump Adjust Fuel Pump	Replace Replace		0.5 1.0	0.8 1.3			3,15 3,15 3	

(1) Group Number	(2) Component/Assembly	(3) Maintenance Function	(4) Maintenance Level					(5) Tools and Equipment	(6) Remarks
			UNIT		DS	GS	DEPOT		
			C	O	F	H	D		
0304	Air Cleaner Air Inlet Housing	Replace		0.5				3	
		Repair		0.2				3	
	Air Cleaner Element	Service	0.5						
		Replace		0.5				3	
	Air Cleaner, Air Inlet Hose and Pipes	Inspect	0.5						
		Replace		0.5				1-3	
	Repair		0.5				1-3		
0306	Tanks, Lines, Fittings, Headers Fuel Tank	Inspect		0.2				1-3	
		Replace		1.8				1-3	
		Repair			3.0			6,7	
	Fuel Cap Fuel Lines and Fittings Fuel Shut-Off Valve	Replace		0.5					
		Replace		0.5				3	
		Inspect	0.1						
	Replace		0.5				3		
0308	Engine Speed Governor and Controls Fuel Metering Pump Governor	Replace			2.0			16,17	
		Repair			4.0			16,17	
0309	Fuel Filters Fuel Filter Assembly	Inspect	0.2						
		Service	0.2	0.5				3	
		Replace		1.2				3	
		Repair		1.0				3	
0311	Engine Starting Aids Fluid Injection Solenoid	Replace		0.3				3	
		Repair		0.8				3	
	Fuel Injection Tube and Fittings Engine Primer Fluid	Replace		1.0				3	
		Repair		1.0				1,3	
		Replace		1.0					

(1) Group Number	(2) Component/Assembly	(3) Maintenance Function	(4) Maintenance Level					(5) Tools and Equipment	(6) Remarks
			UNIT		DS	GS	DEPOT		
			C	O	F	H	D		
0312	<i>Accelerator, Throttle, or Choke Controls</i> Throttle Lever and Cable	Inspect Adjust Replace	0.2	0.5 1.5				3 3	
	Accelerator Pedal and Linkage	Inspect Adjust Replace	0.2	0.5 1.5				3 3	
	Speed Control Shaft	Replace			20.0			3	
04	EXHAUST SYSTEM								
0401	<i>Muffler and Pipes</i> Exhaust Muffler	Inspect Replace		0.2 0.5				3	
	Muffler Extension Stack Assembly	Inspect Replace Repair	0.2	0.5 0.5				3 3	
05	COOLING SYSTEM								
0501	<i>Radiator, Evaporative Cooler, or Heat Exchanger</i> Engine Coolant Heater	Inspect Replace Repair	0.2	1.8 1.2				3 3	
	Radiator	Inspect Test Service Replace Repair	0.2	0.5 0.5 1.5				1-3 1-3 1-3	
	Radiator Strip Radiator Filler Opening Cap	Replace Replace		0.5 0.1	2.2			3,15 3	
0502	<i>Cowling, Deflectors, Air Ducts, Shrouds, Etc.</i> Fan Shroud	Inspect Replace	0.2	1.0				3	

(1) Group Number	(2) Component/Assembly	(3) Maintenance Function	(4) Maintenance Level					(5) Tools and Equipment	(6) Remarks
			UNIT		DS	GS	DEPOT		
			C	O	F	H	D		
0503	<i>Water Manifold, Headers, Thermostats, and Housing Gasket</i> Thermostat Housing and Cover Thermostat Hoses and Clamps	Replace		0.8				3	
		Repair		0.2				3	
		Test		0.2				3,9	
		Replace		0.8				3	
		Inspect Replace	0.2	0.5				3	
0504	<i>Water Pump</i> Water Pump Assembly Belts	Inspect		0.2					
		Replace		2.0				1-3	
		Inspect	0.1						
		Adjust Replace		0.5 1.0				1-3 1-3	
0505	<i>Fan Assembly</i> V-belt Fan Blade, Pulley and Hub	Inspect	0.2						
		Adjust		0.5				1-3	
		Replace		0.8				1-3	
		Inspect Replace	0.2	1.0				1-3	
06	ELECTRICAL SYSTEM								
0601	<i>Generator, Alternator</i> Engine AC Generator Engine AC Generator Mounting Hardware AC Generator Pulley	Test		1.0				1-4	
		Replace		0.5				3	
		Repair			2.0			16,17,23	
		Replace		0.5	3				
0602	<i>Generator Regulator</i> AC Regulator	Replace		0.5				1-3	
		Test		0.5				1-4	
		Replace		0.8				3	

(1) Group Number	(2) Component/Assembly	(3) Maintenance Function	(4) Maintenance Level					(5) Tools and Equipment	(6) Remarks
			UNIT		DS	GS	DEPOT		
			C	O	F	H	D		
0603	Starting Motor Engine Starter	Test			0.5			16,17,23	
		Replace		0.8				3	
		Repair			1.6				16,17,23
0606	Engine Safety Controls Oil Pressure Switch Neutral Safety Switch Brake Light Pressure Switch	Replace	0.2					3	
		Replace	0.2					3	
		Replace	0.2					3	
0607	Instrument or Engine Control Panel Parking Brake Warning Switch, Wiring Harness, Relay, and Warning Light Time Total Meter and Lead Circuit Breakers Cigar Lighter Lead Wire Assembly Dash, Indicators, Lights, and Wiring Harness Ignition Lock Switch Starter Switches Dash and Plexiglass Cover Light Switch and Turn Starting Aid Solenoid	Replace		1.2				3	
		Replace		0.5				3	
		Replace		0.5				3	
		Replace		1.0				3	
		Inspect	0.2						
		Replace		0.8				3	
		Replace		0.5				3	
		Replace		0.5				3	
		Replace		1.5				3	
		Replace		1.5				3	
		Replace		1.2				3	
0608	Miscellaneous Items Cigar Lighter	Replace		0.1				3	

(1) Group Number	(2) Component/Assembly	(3) Maintenance Function	(4) Maintenance Level					(5) Tools and Equipment	(6) Remarks
			UNIT		DS	GS	DEPOT		
			C	O	F	H	D		
0609	<i>Lights</i> Warning Light Assembly	Inspect	0.2						
		Replace		0.8				3	
	Combination Taillight Assemblies	Repair		0.2				3	
		Inspect	0.2						
	Front Light Assembly	Replace		0.8				3	
		Repair		0.2				3	
	Warning Flasher and Bracket	Inspect	0.2						
		Replace		0.8				3	
		Repair		0.2				3	
	0610	<i>Sending Units and Warning Switches</i> Fuel Gage Sender	Replace		1.0				3
0611			<i>Horn, Siren</i> Horn	Replace		0.5			3
Repair		0.5				3			
Horn Switch and Cap	Replace			0.5			3		
Alarm Sensitive Switch	Replace			0.5			3		
Alarm	Replace			1.0			3		
Alarm Ground Wire	Replace			0.5			3		
Assembly	Repair			0.5			3		
0612	<i>Batteries, Storage</i> Batteries, Storage	Inspect	0.2						
		Test		0.1			1-4		
		Service		0.2			1-3		
	Battery Cables and Clamps Battery Tray	Replace		0.8			3		
		Inspect	0.2						
		Replace		0.8			3		
0613	<i>Hull or Chassis Wiring Harness</i> Front and Rear Wiring Harness	Replace		1.5			3		
		Repair		2.0			3		
		Replace		2.0			3		

(1) Group Number	(2) Component/Assembly	(3) Maintenance Function	(4) Maintenance Level					(5) Tools and Equipment	(6) Remarks
			UNIT		DS	GS	DEPOT		
			C	O	F	H	D		
0613	Hull or Chassis Wiring Harness (Con't)								
	Main Wiring Harness	Replace		2.5				3	
07	TRANSMISSION								
0700	Transmission Assembly								
	Hydraulic Transmission	Inspect	0.5		1.0			3,5,15	
		Test						1-3	
		Service	0.5	1.0				3-15	
		Replace				20.0		3-15	
		Repair				17.5		3,8,15	
	Case	Replace				15.5		3,15	
		Repair				8.0		3,15	
	Transmission Case Cover	Replace				1.5		3,15	
0701	Transmission Shafts								
	Countershaft	Replace				10.5		3,15	
		Repair				5.0		3,15	
	Transmission Drive Shaft	Replace				10.5		3,15	
		Repair				5.0		3,15	
0702	Opposed Output								
	Differential Drive Shaft, Gears, and Bearings	Replace				13.5		3,15	
		Repair				1.0		3,15	
	Differential Gear and Pinion	Replace				10.3		3,15	
		Repair				1.0		3,15	
	Lock Assembly	Repair				10.3		3,15	
0704	Transmission Top Cover Assembly								
	Gear Shifters and Shifter Shafts	Repair				10.9		3,15	
	Speed Gear Assembly (Reverser) Top Cover	Replace			2.0			3	
	Transmission Top Cover	Replace				2.0		3,15	
		Repair				2.0		3,15	
	Transmission Dipstick	Replace		0.2					

(1) Group Number	(2) Component/Assembly	(3) Maintenance Function	(4) Maintenance Level					(5) Tools and Equipment	(6) Remarks
			UNIT		DS	GS	DEPOT		
			C	O	F	H	D		
0705	<i>Transmission Shifting Components</i>								
	Transmission Gear Shift Levers	Replace			0.5			3	
	Speed Gear Assembly (Reverser) Control	Inspect		0.5					
	Lever Linkage	Adjust		0.2				3	
	Speed Gear Assembly (Reverser) Control	Repair		2.3	2.5			3	
	Lever	Replace		1.7				3	
0710	<i>Transmission Assembly (Hydraulic, Hydrostatic, Torquomatic, Crossdrive) and Associated Parts</i>								
	Speed Gear Assembly (Reverser)	Inspect	0.5						
		Adjust		2.5				1-3	
		Replace			15.5			3,15	
		Repair			18.0			3,15	
	Speed Gear Assembly (Reverser) Brake Assembly	Replace			15.5			3,15	
		Repair			16.0			3,15	
	Speed Gear Assembly (Reverser) Clutch Drum and Disks	Repair			8.5			3,15	
	Speed Gear Assembly (Reverser) Housing Assembly	Replace			10.5			3,15	
		Repair			5.7			3,15	
0721	<i>Coolers, Pumps, Motors</i>								
	Oil Pump Assembly	Replace			2.0			3,15	
		Repair			2.1			3,15	
	Oil Supply Cover	Replace			2.1			3,15	
	Speed Gear Assembly (Reverser) Clutch	Replace			1.2			3,15	
	Control Valve	Repair			1.8			3,15	
	Speed Gear Assembly (Reverser) Lines and Fittings	Repair			0.8			3	

(1) Group Number	(2) Component/Assembly	(3) Maintenance Function	(4) Maintenance Level					(5) Tools and Equipment	(6) Remarks
			UNIT		DS	GS	DEPOT		
			C	O	F	H	D		
0721	<i>Coolers, Pumps, Motors (Con't)</i>								
	Transmission Relief Valve	Repair			1.5			3,15	
	Transmission Oil Lines and Fittings	Repair				0.8		3,15	
	Transmission Oil Filter	Service		0.3				1-3	
		Replace		0.5				1-3	
	Oil Cooler, Baffles, and Hoses	Inspect	0.5						
		Replace		1.5				1-3	
	Oil Strainer Element	Service		0.1				1-3	
		Replace		0.1				1-3	
10	FRONT AXLE								
1000	<i>Front Axle Assembly</i>								
		Service	0.4						
		Inspect		0.3					
		Replace			3.5			3,15	
		Repair			6.2			3,15	
1004	<i>Steering and Leaning Wheel Mechanism</i>								
	Wheel Spindles and Steering Arms	Repair			2.0	3,15			
11	REAR AXLE								
1103	<i>Planetary or Final Drive</i>								
	Housings	Inspect	0.5						
	Service		0.1						
		Replace			9.5			3,15	
		Repair			2.5			3,15	
	Shafts, Seals, and Bearings	Repair			7.0			3,15	
	Planet, Pinions and Carriers	Repair			7.0			3,15	
12	BRAKES								
1201	<i>Handbrakes</i>								
	Parking Brake Band, Lining, and Linkage Assembly	Adjust		1.0				3	
		Replace			7.5			3,15	
		Repair			1.0			3,15	

(1) Group Number	(2) Component/Assembly	(3) Maintenance Function	(4) Maintenance Level					(5) Tools and Equipment	(6) Remarks
			UNIT		DS	GS	DEPOT		
			C	O	F	H	D		
1201	<i>Handbrakes (Con't)</i> Parking Brake Lever and External Linkage	Repair		2.0				3	
1202	<i>Service Brakes</i> Brake Disk and Pressure Plate	Replace			6.2			3,15	
1204	<i>Hydraulic Brake System</i> Hydraulic Brake System Brake Hydraulic Cylinder Assembly Fittings and Lines	Service Replace Repair Replace		1.5 0.4	1.5 2.3			1-3 3,15 3,15 3	
1206	<i>Mechanical Brake System</i> Brake Pedals	Replace Repair		0.8 0.2				3 3	
13	WHEELS AND TRACKS								
1311	<i>Wheel Assembly</i> Front and Rear Wheel Front Wheel and Hub Bearing	Replace Service Replace		0.8 1.5 2.2				1-3 1-3 1-3	
1313	<i>Tires, Tubes, Tire Chains</i> Front and Rear Tires	Inspect Service Replace Repair	0.2 0.2	1.0 0.6				1-3,10,11 1-3	
14	STEERING								
1401	<i>Mechanical Steering</i> Gear Assembly Tie-rod Assembly Adjust Steering Wheel Steering Column and Bushings	Replace Repair Replace Repair		1.0 2.0 1.2 0.5	2.0			1-3 1-3 1-3 1-3 3,15	

(1) Group Number	(2) Component/Assembly	(3) Maintenance Function	(4) Maintenance Level					(5) Tools and Equipment	(6) Remarks
			UNIT		DS	GS	DEPOT		
			C	O	F	H	D		
1411	Hoses, Lines, Fittings	Replace		1.0				3	
1412	Hydraulic or Air Cylinders	Inspect	0.2						
	Steering Cylinder Assemblies	Service	0.1						
		Replace			4.0			3,15	
		Repair			6.0			3,15	
1414	Steering System Vales	Replace			4.0			3,15	
	Steering Valve Assembly	Repair			6.0			3,15	
15	FRAME, TOWING ATTACHMENTS, DRAWBARS, AND ARTICULATION SYSTEMS								
1501	Frame Assembly	Inspect		0.5					
	Front Support	Replace			6.0			3,15	
		Repair			2.0			3,15	
1502	Counterweights	Replace		1.8				1-3	
	Counterweight Assembly	Repair		1.8				1-3	
18	BODY, CAB, HOOD, AND HULL								
1801	Body, Cab, Hood, and Hull Assemblies	Replace			2.0			3,15	
	Front Canopy Mounts	Replace		1.0				3	
	Back hoe Control Guards	Inspect	0.5						
	Roll-over Protective Structure and Rear	Replace			8.0			3,15	
	Canopy Mountings	Repair			2.0			3,15	
	Canopy Protective Roof	Replace			2.0			3,15	
		Repair			2.5			3,15	
	Cowl Support	Replace			1.5			3,15	
	Cowl	Replace		1.0				1-3	
		Repair		1.2				1-3	

(1) Group Number	(2) Component/Assembly	(3) Maintenance Function	(4) Maintenance Level					(5) Tools and Equipment	(6) Remarks
			UNIT		DS	GS	DEPOT		
			C	O	F	H	D		
1801	<i>Body, Cab, Hood, and Hull Assemblies (Con't)</i> Hood	Replace		1.0				1-3	
		Repair		1.0				1-3	
	Grille Housing Replace		2.0				1-3		
	Hood Side Grille	Repair		1.0				1-3	
		Replace		0.5				3	
1802	<i>Fenders, Running Boards with Mounting and Attaching Parts, Windshield, Glass, Etc.</i> Step	Replace		1.0				3	
		Replace			2.0			3,15	
	Repair			1.0			3,15		
	Stabilizers	Repair		6.0				1-3	
1805	<i>Floors, Subfloors, and Related Components</i> Platforms and Ramps Battery Cover	Replace		1.5				3	
		Replace		1.0				3	
1806	<i>Upholstery, Seats, and Carpets</i> Seat, Seat Support, and Seat Belt	Inspect	0.2						
		Service	0.2						
		Adjust	0.2						
		Repair		2.1				1-3	
1808	<i>Stowage Racks, Boxes, Straps, Carrying Cases, Cable Reels, Hose Reels, Etc.</i> Toolbox and Tray Backhoe Valve Box and Cover Control Box	Replace		0.3				3	
		Replace		1.0				1-3	
		Repair		0.5				1-3	
		Repair		0.5				1-3	

(1) Group Number	(2) Component/Assembly	(3) Maintenance Function	(4) Maintenance Level					(5) Tools and Equipment	(6) Remarks
			UNIT		DS	GS	DEPOT		
			C	O	F	H	D		
22	BODY, CHASSIS, AND HULL ACCESSORY ITEMS								
2202	Accessory Items Reflectors	Replace		0.5				3	
2210	Data Plates and Instruction Holders								
	Data Plates, Decals and Labels	Replace		0.5				1-3	
24	HYDRAULIC AND FLUID SYSTEMS								
2400	Hydraulic and Fluid Systems Hydraulic System	Service Test	0.2	0.1	1.0			1-3 3,24	
2401	Pump and Motor Accumulator Assembly and Bracket	Service Replace Repair		0.5	1.2 2.0			3,12 3,15 3,15	
	Hydraulic Pump Assembly	Test Replace Repair				1.5 2.0 2.5		3,24 3,15 3,15,25	
	Pump Stroke Control Valve Filter Element	Replace		0.5				1-3	
	Pump Drive Shaft and Coupler	Replace Repair			1.0 1.3			3,15 3,15	
2402	Manifold and/or Control Valves								
	Pump Stroke Control Valve	Repair			2.5			3,15,25	
	Pressure Control Valve	Test Repair	1.0 2.0					1,5 1-3	
	Hydraulic Oil Filter Relief Valve and Hoses	Replace Repair	1.5 2.0					1-3 1-3	

(1) Group Number	(2) Component/Assembly	(3) Maintenance Function	(4) Maintenance Level					(5) Tools and Equipment	(6) Remarks
			UNIT		DS	GS	DEPOT		
			C	O	F	H	D		
2402	<i>Manifold and/or Control Valves (Con't)</i>								
	Hydraulic Impactor Valve	Replace		1.0					1-3
	and Flow Regulator	Repair		2.5					1-3
	Jaw Control Valve	Replace		2.0					1-3
	Assembly	Repair				2.5			3,15
	Backhoe Control Valve	Replace		3.5					1-3
	Assembly	Repair			4.0				3,15
	Backhoe Relief Valve	Replace			0.5				3,15
	Cartridges	Repair			0.8				3,15
	Manifold Block	Replace		1.0					1-3
	Loader Control Valve	Replace		2.0					1-3
		Repair			0.5				3,15
	Loader Relief Valve	Replace			0.5				3,15
Cartridge	Repair			0.8				3,15	
2403	<i>Hydraulic Controls and/or Manual Controls</i>								
	Jaw Control Valve	Repair		1.2	3				
	Linkage								
	Backhoe Control Valve	Inspect	0.2						
	Levers and Linkage	Repair		0.5	3				
2406	<i>Strainers, Filters, Lines, and Fittings Etc.</i>								
	Hoses, Fittings, and Lines	Inspect	0.3						
		Replace		1.0					1-3
2407	<i>Hydraulic Cylinders</i>								
	Jaw Cylinder Assembly	Inspect	0.2						
		Replace		0.8					1-3
		Repair			1.5				3,15

(1) Group Number	(2) Component/Assembly	(3) Maintenance Function	(4) Maintenance Level					(5) Tools and Equipment	(6) Remarks
			UNIT		DS	GS	DEPOT		
			C	O	F	H	D		
2407	<i>Hydraulic Cylinders (Con't)</i> Backhoe Crowd Boom, Bucket, and Swing Cylinder Assemblies	Inspect	0.2						
		Service	0.2						
		Replace		0.8				1-3,14	
		Repair				1.5		3,15	
		Inspect	0.2						
		Replace		0.8				1-3	
	Backhoe Stabilizer Cylinder Assemblies	Repair				1.5		3,15	
		Inspect	0.2						
	Loader Bucket Cylinder Assemblies	Service	0.1						
		Replace		0.8				1-3	
	Loader Boom Cylinder Assemblies	Repair				1.5		3,15	
		Inspect	0.2						
		Service	0.1						
		Replace		0.8				1-3	
		Repair				1.2	3,15		
47	GAGES (NONELECTRICAL), WEIGHING AND MEASURING DEVICES								
4701	<i>Instruments</i> Tachometer	Replace		1.0				3	
		Tachometer Drive		1.0				3	
4702	<i>Gages, Mountings, Lines, and Fittings</i> Air Cleaner Restriction Indicator	Inspect	0.2						
		Replace		1.0				3	

(1) Group Number	(2) Component/Assembly	(3) Maintenance Function	(4) Maintenance Level					(5) Tools and Equipment	(6) Remarks
			UNIT		DS	GS	DEPOT		
			C	O	F	H	D		
74	CRANES, SHOVELS, AND EARTHMOVING EQUIPMENT COMPONENTS								
7412	<i>Backhoe Attachments</i>								
	Backhoe Bucket	Adjust		1.0				1-3	
		Repair		2.0				1-3,6,7	
	Dipperstick Assembly	Replace			3.0			3,15	
		Repair			1.2			3,15	
	Dipperstick Hose Guards	Replace		0.2				3	
	Backhoe Boom Assembly	Service	0.5						
		Replace			6.0			3,15	
		Repair			2.2			3,15	
	Swing Frame	Replace			2.5			3,15	
		Repair			1.0			3,15	
	Main Frame	Replace			9.3			3,15	
		Repair			1.0			3,15	
7437	<i>Loader Bucket Assembly or Forklift</i>								
	Loader Lift Arms	Service	0.2						
		Replace			2.5			3,15	
		Repair			1.2			3,15	
	Bucket	Service	0.2						
		Replace		2.0				1-3	
		Repair		2.2				1-3,6,7	
	Side Frames	Replace			6.0			3,15	
		Repair			2.0			3,15	
	Bucket Level Indicator	Adjust		0.5				3	
		Replace		1.0				3	
	Bucket Linkage	Repair		1.5				3	

(1) Group Number	(2) Component/Assembly	(3) Maintenance Function	(4) Maintenance Level					(5) Tools and Equipment	(6) Remarks
			UNIT		DS	GS	DEPOT		
			C	O	F	H	D		
76	FIRE FIGHTING EQUIPMENT COMPONENTS								
7638	Portable Fire Fighting Equipment Fire Extinguisher	Inspect	0.1						
		Replace		0.1					
	Mounting Bracket	Replace		0.2			3		
99	PARTS PECULIAR								
9901	Multilisted Parts								
	Hydraulic Earth Drill Attachment Assembly	Inspect	0.5						
	Hydraulic Earth Drill	Service	0.2						
	Mounting Adapter	Replace		1.3			1-3		
	Hydraulic Earth Drill	Replace		1.3			1-3		
	Auger	Repair		1.4			1-3		
	Hydraulic Earth Drill	Adjust			0.5		3,15	C	
	Boring Head Assembly	Replace		1.3			1-3		
		Repair			2.9		3,15		
	Hydraulic Impactor	Repair		1.0			1-3		
	Mounting Adapter								
	Hydraulic Impactor	Replace		0.8			1-3		
	Working Tools								
	Hydraulic Impactor Attachment Assembly	Inspect	0.5						
	Hydraulic Impactor and Motor Assembly	Service	0.2						
	Hydraulic Attachment, Lines and Fittings	Replace		1.0			1-3		
		Repair			3.1		3,15		
		Inspect	0.5						
		Repair		2.2			1-3		

SECTION III. TOOL AND TEST EQUIPMENT REQUIREMENTS

(1) TOOL OR TEST EQUIPMENT REF CODE	(2) MAINTENANCE CATEGORY	(3) NOMENCLATURE	(4) NATIONAL/NATO STOCK NUMBER	(5) TOOL NUMBER
1	O	Shop Equipment, Automotive Maintenance: Organizational Maintenance Common No. 1 SC 4910-95-CL-A74	4910-00-754-0654	
2	O	Shop Equipment, Automotive Maintenance and Repair: Organizational Maintenance Common No. 2, Less Power SC 4910-95-CL-A72	4910-00-754-0650	
3	O	Tool Kit, General Mechanic's: Automotive, SC 5180-90-CL-N26	5180-00-177-7033	
4	O	Analyzer Set, Engine: Portable Solid State (STE/ICEPM)	4910-00-124-2554	2389409
5	O	Tool Outfit, Hydraulic System Test and Repair, 3/4-Ton Trailer Mounted	4910-01-036-5784	13221E 6850
6	O	Tool Kit, Welder's SC 5180-90-CL-N39	5180-00-754-0661	7540661
7	O	Welding Set, Arc: Inert Gas Shielded, DC 115V	3431-00-079-0488	MILW521612351-0685
8	O	Cleaner, Steam/High Pressure - Hot Water Jet: Wheel Mounted	4940-01-025-9856	11020600
9	O	Thermometer	6685-00-174-6235	
10	O	Multiplier, Torque Wrench, 1200 Foot- Pound Capacity, 3/4-Inch Drive	5120-00-169-2986	
11	O	Bar, Torque Wrench 5120-01-008-3632		
12	O	Accumulator Charging Tools: Charging Kit, Accumulator, Nuday Connector, John Deere Hose, John Deere		ND-925-0(-W) R40617 AR47753
13	O	Tester, Spring, 4 to 400-Pound Capacity	5120-00-937-7265	
14	O	Tool, Backhoe Swing Cylinder Pin Removal (See Appendix D): Pipe, Metallic Screw, Cap Washer, Flat	4710-00-836-8419 5305-00-616-3641 5305-01-085-1734	

SECTION III TOOL AND TEST EQUIPMENT REQUIREMENTS

(1) TOOL OR TEST EQUIPMENT REF CODE	(2) MAINTENANCE CATEGORY	(3) NOMENCLATURE	(4) NATIONAL/NATO STOCK NUMBER	(5) TOOL NUMBER
15	F	Shop Equipment, Automotive Maintenance and Repair: Field Maintenance, Basic, Less Power SC 4910-95-CL-A31	4910-00-754-0705	
16	F	Tool Kit, Automotive Fuel and Electrical System Repair SC 5180-95-CL-B08	5180-00-754-0655	
17	F	Shop Equipment, Electrical Repair, Semitrailer Mounted, SC 4940-95-CL-B05	4940-00-287-4894	
18	F	Adapter, Lifting, John Deere		JD-244
19	F	Clutch Rebuild	4910-00-814-6299	
20	F	Tool, Clutch Aligning, John Deere		JDE-52
21	F	Fuel Injection Nozzle Tools:		
		Brush, Brass Wire, 16488		
		Service Tools		
		Wire, Cleaning,		16485
		Service Tools, 0.008-Inch		
		Wire, Cleaning,		16486
		Service Tools, 0.01-Inch		
		Magnifier, Inspection,		16487
		Service Tools		
		Fixture, Nozzle Holding,		16475
		Service Tools		
		Drill, Sac Hole,		16476
		Service Tools		
		Scraper, Tip Seat,		16482
		Service Tools		
		Retractor, Valve,		16481
		Service Tools		
22	H	Tester, Diesel Fuel Injector Nozzle	4910-00-255-8641	MILT 45049
23	F	Test Stand, Automotive	4910-00-767-0218	
		Generator and Starter		

SECTION III TOOL AND TEST EQUIPMENT REQUIREMENTS

(1) TOOL OR TEST EQUIPMENT REF CODE	(2) MAINTENANCE CATEGORY	(3) NOMENCLATURE	(4) NATIONAL/NATO STOCK NUMBER	(5) TOOL NUMBER
24	F	Hydraulic System Service and Test Tools: Elbow, 90°, John Deere (two required) Filter Assembly, John Deere Filter Element, 10-Micron, John Deere (two required) Hose, John Deere O-Ring, John Deere (two required)		AT36607 AT62042 AT39361 AU43842 U13639
25	F	Hydraulic Pump Tools: Driver, John Deere Driver, John Deere		JDE-54 JDH-18
26	F	Gage, Clutch, Finger, Aligning, John Deere		JD-7

SECTION IV. REMARKS

(1) Reference Code	(2) Remarks
A	Manifold block-to-rod end boom cylinder oil line must be removed and installed at Direct Support Maintenance level after backhoe boom cylinder removal.
B	Tools and Equipment code 14 required only for swing cylinder maintenance. Backhoe boom cylinder must be removed and installed at Direct Support Maintenance level after backhoe boom removal
C	Adjustment consists of adjusting chain tension.

Change 1 B-25/(B-26 blank)

**APPENDIX C
EXPENDABLE SUPPLIES AND MATERIALS LIST**

	Page
Section I Introduction.....	C-1
Section II Expendable Supplies and Materials List	C-2

Section I. INTRODUCTION

	Page		Page
Explanation of Columns	C-1	Scope	C-1

SCOPE

This appendix lists expendable supplies and materials you will need to operate and maintain the loader backhoe. These items are authorized to you by CTA 50-970, Expendable/Durable Items (except Medical, Class V, Repair Parts, and Heraldic Items).

EXPLANATION OF COLUMNS

Column 1, Item Number. This number is assigned to the entry in the listing and is referenced in the narrative instructions to identify the material (e.g., "Solvent, dry-cleaning (item 28, Appendix C)').

Column 2, Level. This column identifies the lowest level of maintenance that requires the listed item.

- C - Operator/Crew
- O - Organizational Maintenance

Column 3, National Stock Number. This is the national stock number assigned to the item, use it to request or requisition the item.

Column 4, Description. Indicates the federal item name and, if required, a description to identify the item. The last line for each item indicates the Federal Supply Code for Manufacturer (FSCM) in parenthesis followed by the part number.

Column 5, Unit of Measure (U/M). Indicates the measure used in performing the actual maintenance function. This measure is expressed by a two-character alphabetical abbreviation (e.g., ea, in., pr). If the unit of measure differs from the unit of issue, requisition the lowest unit of Issue that will satisfy your requirements.

Section II. EXPENDABLE SUPPLIES AND MATERIALS LIST

(1)	(2)	(3)	(4)	(5)
ITEM NUMBER	LEVEL	NATIONAL STOCK NUMBER	DESCRIPTION (FSCM)	U/M
1	O	8040-00-880-7332	Adhesive, Metal Bonding: 12-ounce (355-ml) can (01139) RTV118	oz
2	O	6810-00-201-0906	Alcohol, Denatured, Type III: 1-pint (0.473-liter) bottle (81348) O-E760	oz
3			Antifreeze, Ethylene, Glycol Inhibited, Heavy Duty: (81349) MI L-A-46153	
	O	6850-00-181-7933	5-gallon (18.93-liter) can	gl
	O	6850-00-181-7940	55-gallon (208-liter) drum	gl
4	O	6850-00-319-0834	Cleaning Compound, Solvent (Electrical Parts) (Trichlorotrifluoroethane): 11-pound (4.99-kg) bottle (81349) (MIL-C-81302)	lb
5	O	8030-00-145-0151	Coating Compound, Plastic: (81349) M IL-P-20689	kt
6	O	5350-00-221-0872	Crocus Cloth, Abrasive: 50-sheet package (58536) A-A-1206	sh
7	C	7930-00-282-9699	Detergent, GP, Liq, WS, A: 1-gallon (3.785-liter) can (81349) MIL-D-16791	gl
8			Diesel Fuel	
C		9140-00-286-5294	Regular Grade: 55-gallon (208-liter) drum (81348) VVF800 GRADE DF2RE	gl
C		9140-00-286-5286	Winter Grade: 55-gallon (208-liter) drum (81348) VVF800 GRADE DF1WI	gl
C		9140-00-286-5283	Arctic Grade: 55-gallon (208-liter) drum (81348) VVF800 GRADE DFARR	gl

EXPENDABLE SUPPLIES AND MATERIALS LIST - CONTINUED

(1)	(2)	(3)	(4)	(5)
ITEM NUMBER	LEVEL	NATIONAL STOCK NUMBER	DESCRIPTION (FSCM)	U/M
9	C	6810-00-107-1510	Distilled Water, ACS 1: 5-gallon (18.9-liter) bottle (81348) O-C-265	gl
10	O	4730-00-050-4280	Fitting, Lubrication Straight: 0.125-inch NPTF (96906) MS15003-1	ea
	O	4730-00-050-4203	Straight: 0.25-inch PTF-SPL SHORT (96906) MS15001-1	ea
	O	4730-00-050-4205	Angle, 45 degree: 0.25-inch SAE-LT (96906) MS15001-3	ea
	O	4730-00-050-4207	Angle, 90 degree: 0.25-inch SAE-LT (96906) MS15001-4	ea
11			Fluid, Hydraulic, Petroleum Base: (81349) MIL-H-6083	
C		9150-00-935-9809	5-gallon Can	gl
	O	9150-00-935-9810	55-gallon Drum	gl
12	O	3439-00-255-9935	Flux, Soldering (Rosin Base): (81348) OF506	lb
13	C	9150-00-926-8963	Graphite, Colloidal (Dry Film oz Lubricant) (GG): 2-ounce (59 ml) applicator bottle (81349) MIL-L-24131	
14			Grease, Automotive and Artillery (GAA): (81349) MIL-G-10924	
	C	9150-00-190-0905	5-pound (2.27-kg) can	lb
	O	9150-00-190-0907	35-pound (15.89-kg) can	lb
15	O	5970-00-815-1295	Insulation, Sleeving (Shrinkable Tubing): (81349) MIL-I-23053/5	ft

Change 1 C-3

EXPENDABLE SUPPLIES AND MATERIALS LIST - CONTINUED

(1)	(2)	(3)	(4)	(5)
ITEM NUMBER	LEVEL	NATIONAL STOCK NUMBER	DESCRIPTION (FSCM)	U/M
16	O	9150-01-035-9142	Lubricant, Impactor: 14-ounce (414-ml) cartridge (74684) HTC-AE988	oz
17	O	6830-00-782-2642	Nitrogen, Technical, Oil Pumped Compression Type: 187-cubic foot (5.295 cubic meter) cylinder (81348) BB-N-411	ft ³
18			Oil, Lubricating, Gear (GO) (81349) MIL-L-2105	
	O	9150-01-035-5392	1-quart (0.946-liter) can	qt
	O	9150-01-035-5393	5-gallon (18.9-liter) can	gl
	O	9150-01-035-5394	55-gallon (208-liter) drum	gl
19			Oil, Lubricating, Internal Combustion Engine: (81349) MIL-L-2104	
			OE/HDO/10	
	C	9150-00-186-6668	5-gallon (18.93-liter) can	gl
	O	9150-00-265-9429	55-gallon (208-liter) drum	gl
			OE/HDO/30	
	C	9150-00-188-9858	5-gallon (18.93-liter) can	gl
	O	9150-00-188-9859	55-gallon (208-liter) drum	gl
			OEA, Arctic: (81349) MIL-L-46167	
	C	9150-00-402-2372	5-gallon (18.93-liter) can	gl
	O	9150-00-491-7197	55-gallon (208-liter) drum	gl
20	O	5350-00-598-5537	Paper, Abrasive: Fine (58536) A-A-1202	sh
21	C	7920-00-205-1711	Rags, Wiping: 50-pound (22.7-kg) bale (58536) A-A-531	bl

EXPENDABLE SUPPLIES AND MATERIALS LIST - CONTINUED

(1)	(2)	(3)	(4)	(5)
ITEM NUMBER	LEVEL	NATIONAL STOCK NUMBER	DESCRIPTION (FSCM)	U/M
22	O	5320-00-932-1972	Rivet, Blind: 0.125-inch nom shank 0.063 to 0.125-inch grip length (81349) M24243/6-A402H	ea
23	O	8030-00-081-2336	Sealing Compound, Gasket, Type I: 2-ounce (59-ml) tube (77247) MI L-S-45180	oz
24	O	8030-00-247-2524	Sealing Compound, Thread: 1.06-pint (0.05-liter) bottle (81349) MIL-S-22473	oz
25	O	6810-00-264-6618	Sodium Bicarbonate (Baking Soda): (81348) O-S-576	lb
26	O	3349-01-007-5491	Solder, Tin Alloy (Rosin Core): (81348) QQ-S-571	ro
27	O	6850-00-292-9700	Solvent, Cleaning Compound (Water Soluble): 5-gallon (18.9-liter) can (81348) O-C-1824	gl
28			Solvent, Dry-cleaning, Type II: (81348) P-D 680	
	C	6850-00-664-5685	1-quart (0.946-liter) can	qt
	C	6850-00-281-1985	1-gallon (3.785-liter) can	gl
	O	6850-00-285-8011	55-gallon (208-liter) drum	gl
29	O	5975-00-984-6582	Strap, Tiedown, Electrical (Tie Wrap): (81349) MIL-S-23190	ea
30	O	9905-00-537-8954	Tags, Marking: (81349) MIL-T-12755	ea
31	O	5640-00-103-2254	Tape, Duct: 60-Yard (54-m) Roll (07124) C-519	yd
32	O	5970-00-543-1154	Tape, Insulation, Electrical: (81349) MIL-1-15126	ro

EXPENDABLE SUPPLIES AND MATERIALS LIST - CONTINUED

(1)	(2)	(3)	(4)	(5)
ITEM NUMBER	LEVEL	NATIONAL STOCK NUMBER	DESCRIPTION (FSCM)	U/M
33	O	4020-00-998-4423	Tape, Lacing and Tying (Type P, Class 2: 250-yard (229-m) spool (82110) MIL-T-713	ft
34	C	7510-00-266-6710	Tape, Pressure Sensitive: (96906) MS16698-73	yd
35	O	9505-00-293-4208	Wire, Non-Electrical (Lockwire): (96906) MS20995C32 (81348) QQW423	lb

APPENDIX D

ILLUSTRATED LIST OF MANUFACTURED ITEMS

	Page
Section I Introduction.....	D-1
Section II Manufactured Items Part Number Index	D-1
Section III Manufactured Items Illustrations	D-2

Section I. INTRODUCTION

This appendix includes complete instructions for making items authorized to be manufactured or fabricated at Organizational Maintenance.

A part number index in alphanumeric order is provided for cross-referencing the part number of the item to be manufactured to the illustration showing manufacturing requirements.

All bulk materials needed to manufacture the item are listed by part number or specification number in a tabular list on the illustration.

Section II. MANUFACTURED ITEMS PART NUMBER INDEX

PART NUMBER	FIGURE NUMBER	DESCRIPTION
AT32064-	D-1	Hose
AT32064-	D-1	Hose
NONE	D-11	Hose, Rubber
NONE	D-13	Hose, Nonmetallic
NONE	D-14	Tool
NONE	D-15	Tool
R3603	D-12	Tubing, Nonmetallic
R32007-1	D-7	Wire Assembly
R32008-1	D-5	Wire Assembly
R32008-	D-6	Wire Assembly
R35416-20	D-4	Strip, Packing
R57300-4	D-10	Hose
R58921-22	D-9	Hose
T34589-2	D-3	Tube, Nonmetallic
T61939-10	D-9	Hose
U11186-10	D-8	Hose
U11186-	D-8	Hose
1608098-5	D-2	Hose, Metal

Section III. MANUFACTURED ITEMS ILLUSTRATIONS

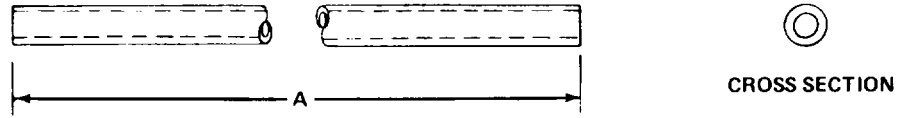

DESCRIPTION: HOSE

PART NUMBER: AT32064 - DIMENSION A=1.40 INCH (35.56 MM) (TWO USED)

AT32064 - DIMENSION A=4.43 INCHES (112.52 MM) (THREE USED)

MAKE FROM: PART NUMBER AT32064 BULK STOCK

TOOLS REQUIRED FOR FABRICATION: KNIFE, POCKET

RULE, STEEL, MACHINIST'S, 6 INCH

Figure D-1. Fuel Injection Hoses (Engine Serial Numbers 505340 and Below).

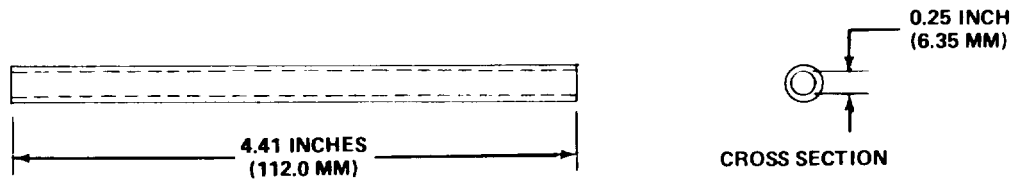

DESCRIPTION: HOSE, METAL
PART NUMBER: 1608098-5
MAKE FROM: NSN 4720-01-160-8098
TOOLS REQUIRED FOR FABRICATION: CUTTER, TUBE
RULE, STEEL, MACHINIST'S, 6 INCH

Figure D-2. Fuel Injection Hoses (Engine Serial Numbers 505341 and Above).

TA243648

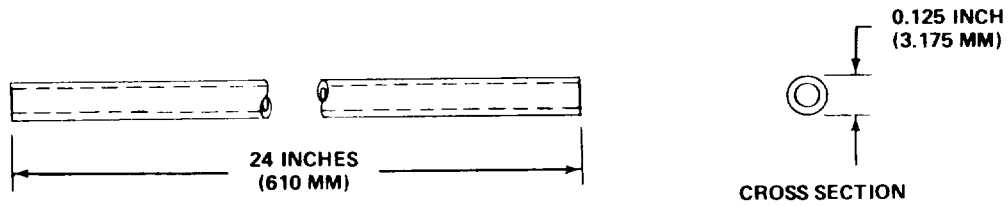

DESCRIPTION: TUBE, NONMETALLIC
PART NUMBER: T34589-2
MAKE FROM: PART NUMBER T34589 BULK STOCK
TOOLS REQUIRED FOR FABRICATION: KNIFE, POCKET
TAPE, MEASURING, 78 3/4 INCH

Figure D-3. Engine Starting Aid Fluid Injection Tube (Serial Numbers 319995 thru 342573).

TA243649

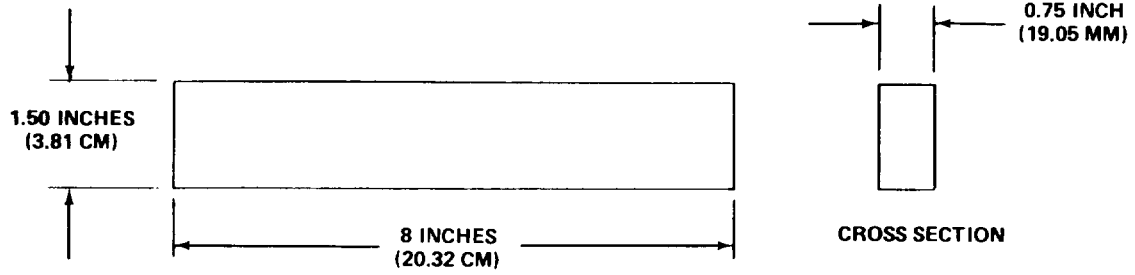

DESCRIPTION: STRIP, PACKING
PART NUMBER: R35416-20
MAKE FROM: R35416
TOOLS REQUIRED FOR FABRICATION: SHEARS, BENT, TRIMMERS
TAPE, MEASURING, 78 3/4 INCH

TA243650

Figure D-4. Radiator Packing Strip.

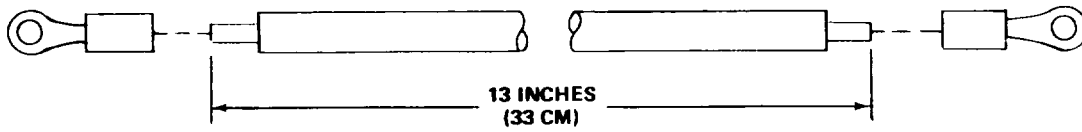

DESCRIPTION: WIRE ASSEMBLY
PART NUMBER: R32008-1
MAKE FROM: R32008 WIRE
R32019 TERMINAL LEAD
R32021 TERMINAL LEAD

NOTE:
FOR INFORMATION ON HOW TO REPLACE WIRES,
GO TO GENERAL MAINTENANCE INSTRUCTIONS
(PAGE XXX).

TOOLS REQUIRED FOR FABRICATION: CRIMPING TOOL, TERMINAL
PLIERS, DIAGONAL CUTTING
STRIPPER, WIRE
TAPE, MEASURING, 78 3/4 INCH

TA243651

Figure D-5. Cigar Lighter Ground Assembly (Serial Numbers 235786 thru 235999 Only).

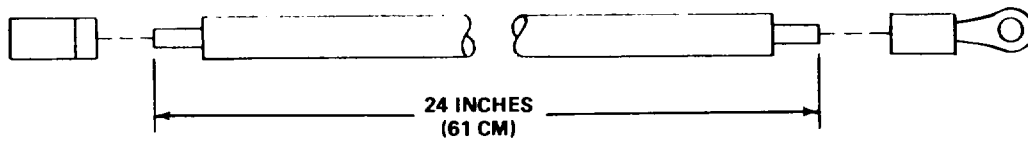

DESCRIPTION: WIRE ASSEMBLY
PART NUMBER: R32008- _____
MAKE FROM: R32008 WIRE
R65600 TERMINAL, FEMALE
R32021 TERMINAL LEAD

NOTE:
FOR INFORMATION ON HOW TO REPLACE WIRES,
GO TO GENERAL MAINTENANCE INSTRUCTIONS
(PAGE XXX).

TOOLS REQUIRED FOR FABRICATION: CRIMPING TOOL, TERMINAL
PLIERS, DIAGONAL CUTTING
STRIPPER, WIRE
TAPE, MEASURING, 78 3/4 INCH

TA243652

Figure D-6. Cigar Lighter Ground Assembly (Serial Numbers 319995 thru 3425739 Only).

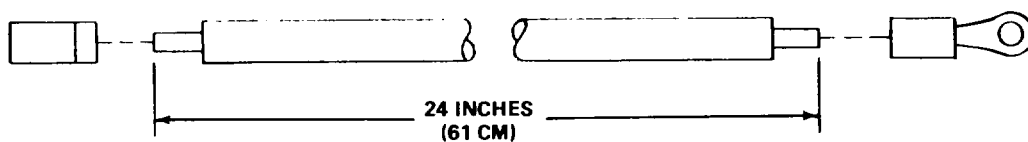

DESCRIPTION: WIRE ASSEMBLY
PART NUMBER: R32008- _____
MAKE FROM: R32008 WIRE
R65600 TERMINAL, FEMALE
R32021 TERMINAL LEAD

NOTE:
FOR INFORMATION ON HOW TO REPLACE WIRES,
GO TO GENERAL MAINTENANCE INSTRUCTIONS
(PAGE XXX).

TOOLS REQUIRED FOR FABRICATION: CRIMPING TOOL, TERMINAL
PLIERS, DIAGONAL CUTTING
STRIPPER, WIRE
TAPE, MEASURING, 78 3/4 INCH

TA243653

Figure D-7. Reverse Warning Alarm Ground Wire Assembly.

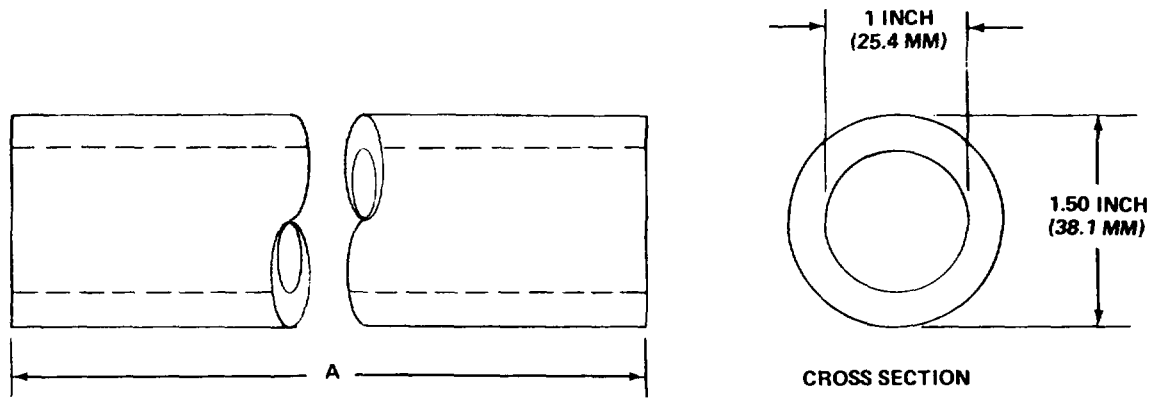

DESCRIPTION: HOSE
PART NUMBER: U11186-10 DIMENSION A=3.00 INCHES (76.20 MM)
 U11186-__ DIMENSION A=3.125 INCHES (79.375 MM)
MAKE FORM: NSN4720-01-198-2823
TOOLS REQUIRED FOR FABRICATION: KNIFE, POCKET
 RULE, STEEL, MACHINIST'S, 6 INCH

TA243654

Figure D-8. One-Inch Low Pressure Hydraulic Line Oil Hoses.

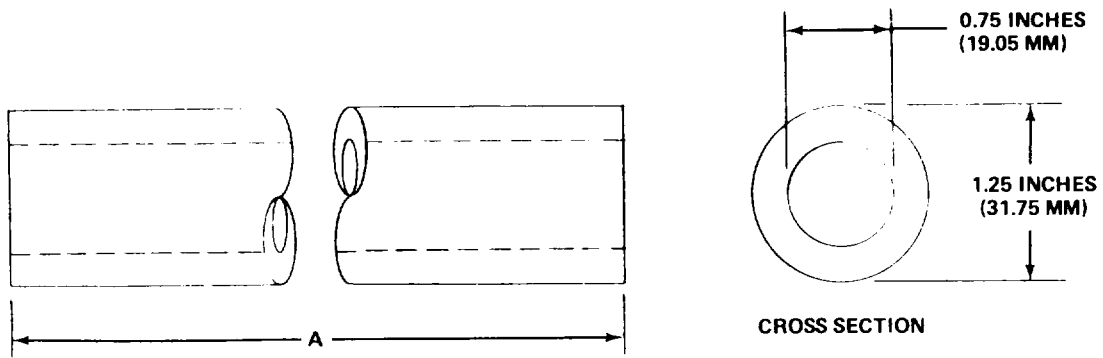

DESCRIPTION: HOSE
PART NUMBER: T61939-10 DIMENSION A=2.25 INCHES (57.15 MM)
MAKE FROM: NSN4720-01-192-9649 BULK STOCK

DESCRIPTION: HOSE
PART NUMBER: R58921-22 DIMENSION A=22 INCHES (558.8 MM)
MAKE FROM: 22 1/2-INCH HOSE, PART NUMBER R58921
TOOLS REQUIRED FOR FABRICATION: KNIFE, POCKET
TAPE, MEASURING, 78 3/4 INCH

Figure D-9. Three-Quarter Inch Low Pressure Hydraulic Line Oil Hoses (Serial Numbers 319995 thru 342573 Only).

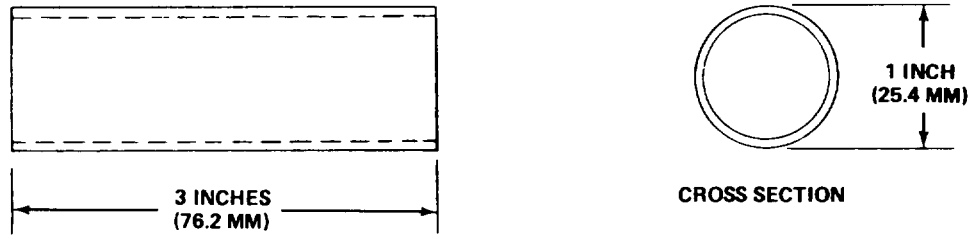

DESCRIPTION: HOSE
PART NUMBER: R57300-4
MAKE FROM: NSN4720-01-197-4794
TOOLS REQUIRED FOR FABRICATION: KNIFE, POCKET
RULE, STEEL, MACHINIST'S, 6 INCH

TA243656

Figure D-10. Loader Control Valve-to-Hydraulic Oil Filter Relief Hose (Serial Numbers 319995 thru 342573).

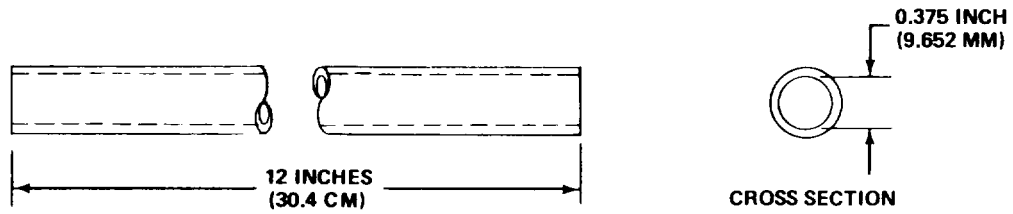

DESCRIPTION: HOSE, RUBBER
PART NUMBER: NONE
MAKE FROM: NSN 4720-00-720-1096 (MIL-H-5593-6), OR SIMILAR SUBSTITUTE
TOOLS REQUIRED FOR FABRICATION: KNIFE, POCKET TAPE, MEASURING, 78 3/4 INCH

TA243657

Figure D-11. Fuel or Cooling System Draining Rubber Hose.

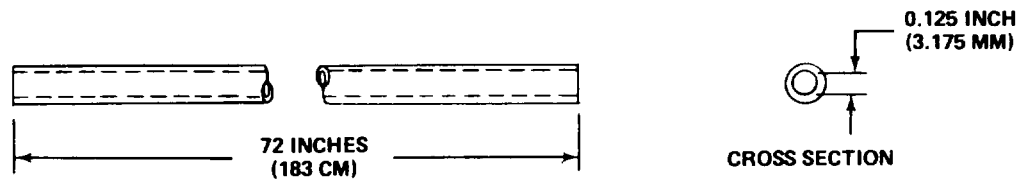

DESCRIPTION: TUBING, NONMETALLIC
PART NUMBER: R3603
MAKE FROM: NSN 4720-00-818-3478
TOOLS REQUIRED FOR FABRICATION: KNIFE, POCKET
TAPE, MEASURING, 78 3/4 INCH

Figure D-12. Brake Bleeding Nonmetallic Tubing.

TA243658

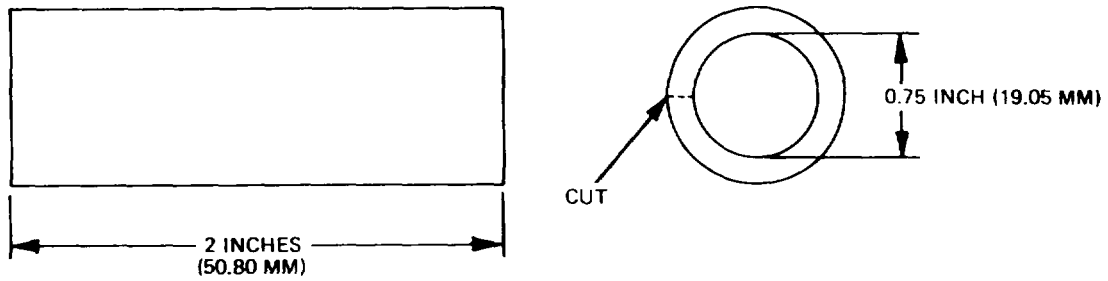

DESCRIPTION: HOSE, NONMETALLIC
PART NUMBER: NONE
NOTE: SLIT ISOLATOR WITH POCKET KNIFE TO ALLOW INSTALLATION OVER
JAW CONTROL HOSE.
TOOLS REQUIRED FOR FABRICATION: KNIFE, POCKET
RULE, STEEL, MACHINISTS, 6-INCH

TA243659

Figure D-13. Jaw Control Hose Isolator.

MANUFACTURED ITEMS ILLUSTRATIONS - CONTINUED

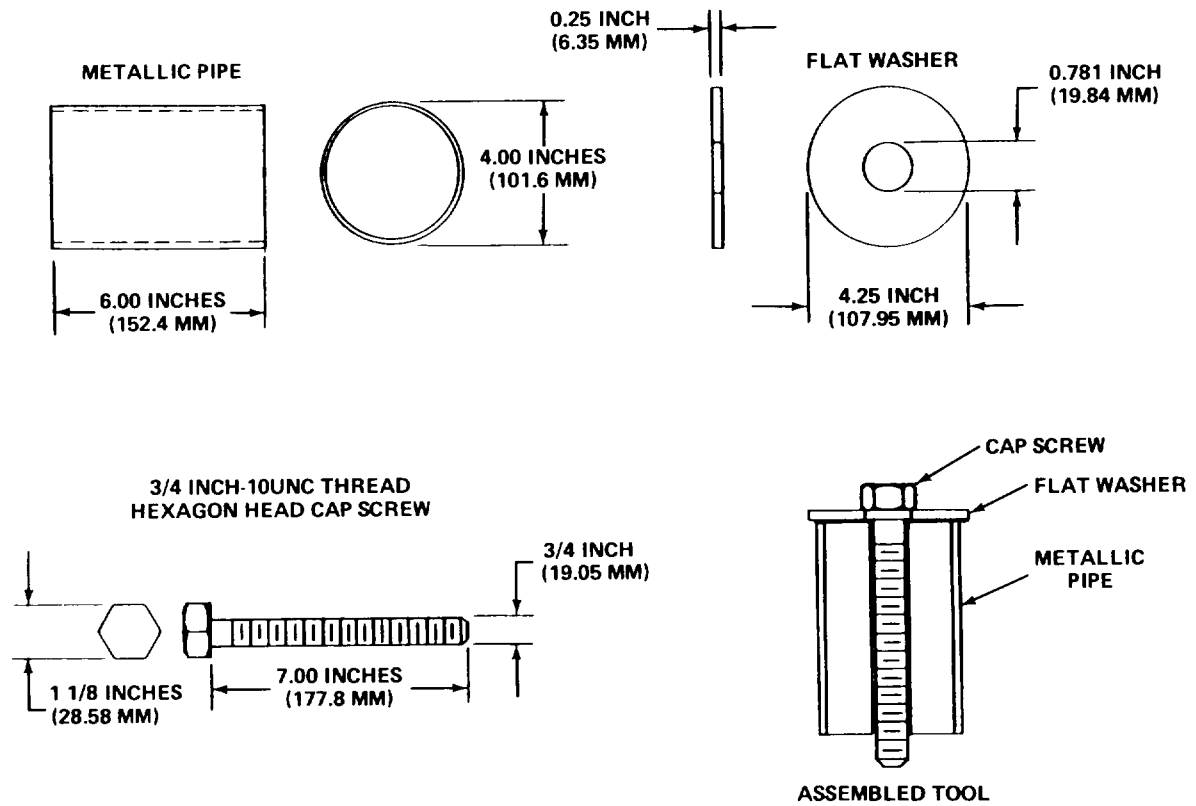

DESCRIPTION: TOOL, USED TO REMOVE BACKHOE SWING CYLINDER PIN

PART NUMBER: NONE

MAKE FROM: PIPE, METALLIC, NSN 4710-00-83648419
 SCREW, CAP, HEXAGON HEAD, 3/4 INCH-10UNC THREAD,
 7 INCHES LONG, NSN 5305-00-616-3641
 WASHER, FLAT, 0.781 INCH HOLE, 4.25 INCH OUTSIDE DIAMETER,
 0.25 INCH THICK NSN 5310-01-085-1734

NOTE:

TO ASSEMBLE TOOL, PLACE CAP SCREW THROUGH HOLE IN FLAT WASHER AND INTO METALLIC PIPE

TOOLS REQUIRED FOR FABRICATION: HACKSAW
 RULE, STEEL, MACHINIST'S, 6
 INCH VISE, MACHINIST'S

Figure D-14. Backhoe Swing Cylinder Pin Removal Tool.

TA243660

MANUFACTURED ITEMS ILLUSTRATIONS - CONTINUED

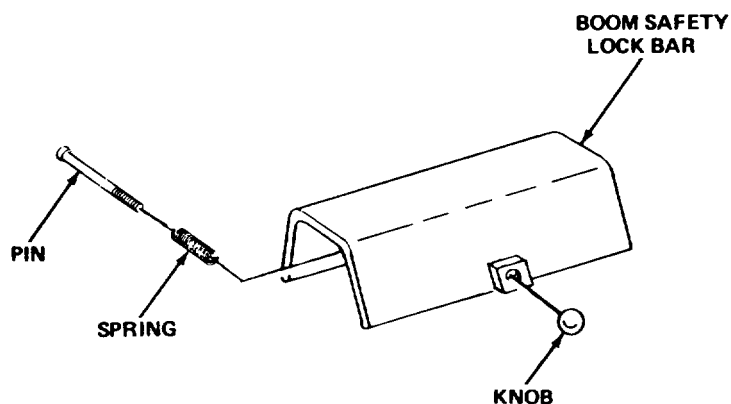

DESCRIPTION: TOOL, USED TO SUPPORT LOADER BUCKET

PART NUMBER: NONE

MAKE FROM: SPRING, PART NUMBER T41597

BOOM SAFETY LOCK BAR, PART NUMBER AT40572

KNOB, PART NUMBER M526T

NSN 5355-01- 99-4447

PIN, PART NUMBER T41596

NOTES:

1. PUT SPRING ON PIN.
2. PUT PIN WITH ASSEMBLED SPRING THROUGH HOLE IN BOOM SAFETY LOCK BAR FROM INSIDE OUT.
3. SCREW KNOB ONTO PIN.

Figure D-15. Bucket Support.

TA243661

**APPENDIX E
TORQUE LIMITS**

CAPSCREW MARKING

Current Usage	Much Used	Much Used	Used at Times	Used at Times
Quality of Material	Indeterminate	Minimum Commercial	Medium Commercial	Best Commercial
SAE Grade Number	1 or 2	5	6 or 7	8

Capscrew Head Markings

Manufacturer's marks may vary

These are all SAE Grade 5 (3 line)

TORQUE VALUES

CAUTION

If replacement capscrews are of a higher grade than originally supplied, use torque specifications for that placement. This will prevent equipment damage due to overtorquing.

Capscrew Body Size (Inches) - (Thread)		Torque Ft Lb (N•m)		Torque Ft Lb (N•m)		Torque Ft Lb (N•m)		Torque Ft Lb (N•m)	
1/4	20	5	(7)	8	(11)	10	(14)	12	(16)
	28	6	(8)	10	(14)			14	(19)
5/16	18	11	(15)	17	(23)	19	(26)	24	(33)
	24	13	(18)	19	(26)			27	(37)
3/8	16	18	(24)	31	(42)	34	(46)	44	(60)
	24	20	(27)	35	(47)			49	(66)
7/16	14	28	(38)	49	(66)	55	(75)	70	(95)
	20	30	(41)	55	(75)			78	(106)
1/2	13	39	(53)	75	(102)	85	(115)	105	(142)
	20	41	(56)	85	(115)			120	(163)
9/16	12	51	(69)	110	(149)	120	(163)	155	(210)
	18	55	(75)	120	(163)			170	(231)
5/8	11	83	(113)	150	(203)	167	(226)	210	(285)
	18	95	(129)	170	(231)			240	(325)
3/4	10	105	(142)	270	(366)	280	(380)	375	(508)
	16	115	(156)	295	(400)			420	(569)
7/8	9	160	(217)	395	(536)	440	(597)	605	(820)
	14	175	(237)	435	(590)			675	(915)
1	8	235	(319)	590	(800)	660	(895)	910	(1234)
	14	250	(339)	660	(895)			990	(1342)

INDEX

Subject	Page
A	
Accumulator charging, hydraulic	2-1194
Administrator storage of army material	2-1897
Air cleaner restoration indicator.....	2-1792
Auger, hydraulic earth drill.....	2-1866
B	
Backhoe bucket.....	2-1795
Backhoe bucket cylinder	2-1726
Backhoe bucket linkage	2-1818
Backhoe bucket teeth.....	2-1815
Backhoe control valve	2-1260
Backhoe control valve hydraulic impactor return oil line (serial numbers 319995 thru 342573 only), boom-to-backhoe control valve levers and linkage (serial numbers 235786 thru 235999 only).....	2-1302
Backhoe control valve levers and linkage (serial numbers 319995 thru 342573 only).....	2-1314
Backhoe control valve oil line (serial numbers 319995 thru 342573 only), jaw direct linear valve-to -.....	2-1436
Backhoe control valve-to-backhoe stabilizer cylinder oil line.....	2-1622
Backhoe control valve-to-backhoe swing cylinder oil line.....	2-1636
Backhoe control valve-to-jaw direct valve oil line (serial numbers 319995 thru 342573 only)	2-1412
Backhoe control valve-to-manifold block oil lines.....	2-1558
Backhoe control valve-to-manifold oil lines (serial numbers 235786 thru 235999 only)	2-1429
Backhoe crowd cylinder.....	2-1740
Backhoe dipperstick hose guards (serial numbers 319995 thru 342573 only).....	2-1826
Backhoe stabilizer cylinder oil lines, backhoe control valve-to-.....	2-1622
Backhoe stabilizer cylinders	2-1752
Backhoe swing cylinder oil lines, backhoe control valve-to-.....	2-1636
Backhoe swing cylinders	2-1708
Bleed oil line, hydraulic earth drill.....	2-1550
Block, manifold	2-1270
Boom bucket cylinder oil lines, manifold block-to-.....	2-1590
Boom jaw control oil hoses (serial numbers 235786 thru 235999 only), manifold block-to-	2-1522
Boom jaw control oil tubes (serial numbers 319995 thru 342573 only), manifold block-to-	2-1526
Boom oil line (serial numbers 235786 thru 235999 only), hydraulic impactor flow regulator-to-	2-1499
Boom oil line (serial numbers 319995 thru 342573 only), hydraulic impactor flow regulator-to-	2-1505
Boom oil lines (serial numbers 235786 thru 235999 only), quick coupler-to-	2-1472
Boom oil lines (serial numbers 319995 thru 342573 only), quick coupler-to-	2-1477

INDEX - CONTINUED

Subject	Page
B - CONTINUED	
Boom-to-backhoe control valve hydraulic impactor return oil line (serial numbers 319995 thru 342573 only).....	2-1489
Boom-to-bucket cylinder oil lines (serial numbers 235786 thru 235999 only).....	2-1598
Boom-to-bucket cylinder oil lines (serial numbers 319995 thru 342573 only).....	2-1608
Boom-to-jaw cylinder oil hose oil lines (serial numbers 235786 thru 235999 only).....	2-1532
Boom-to-jaw cylinder oil hose oil lines (serial numbers 319995 thru 342573 only).....	2-1538
Boom-to-manifold hydraulic impactor return oil line (serial numbers 235786 thru 235999 only)	2-1483
Boring head, hydraulic earth drill.....	2-1870
Bracket, jaw control (direct linear) valve.....	2-1298
Bracket, loader control valve mounting	2-1282
Bucket, backhoe.....	2-1795
Bucket cylinder oil lines (serial numbers 235786 thru 235999 only), boom-to-.....	2-1598
Bucket cylinder oil lines (serial numbers 319995 thru 342573 only), boom-to-.....	2-1608
Bucket, loader	2-1833
Bucket support, loader	2-1830

C

Cable, tachometer drive	2-1789
Charging, hydraulic accumulator.....	2-1194
Clutch control valve adapter oil line, hydraulic oil filter relief valve-to-.....	2-1346
Clutch control valve oil line, hydraulic oil cooler-to-.....	2-1361
Clutch control valve-to-hydraulic pump inlet oil line.....	2-1352
Control valve, backhoe.....	2-1260
Control valve levers and linkage (serial numbers 235786 thru 235999 only), backhoe.....	2-1302
Control valve levers and linkage (serial numbers 319995 thru 342573 only), backhoe.....	2-1314
Control valve loader.....	2-1285
Control valve, pressure.....	2-1200
Control valve (serial numbers 235786 thru 235999 only), jaw	2-1242
Cooler hose (serial numbers 319995 thru 342573 only), hydraulic pump-to-hydraulic oil.....	2-1338
Cranes, shovels, and earthmoving equipment components	2-1795
Crowd cylinder oil lines (serial numbers 235786 thru 235999 only), manifold block-to-.....	2-1570
Crowd cylinder oil lines (serial numbers 319995 thru 342573 only), manifold block-to-.....	2-1578
Cylinder, backhoe bucket.....	2-1726
Cylinder, backhoe crowd	2-1740

INDEX - CONTINUED

Subject	Page
C - CONTINUED	
Cylinder, jaw.....	2-1703
Cylinders, backhoe stabilizer.....	2-1752
Cylinders, backhoe swing.....	2-1708
Cylinders, loader boom.....	2-1770
Cylinders, loader bucket.....	2-1760

D

Diagram (serial numbers 235786 thru 235999 only), hydraulic system.....	2-1779
Diagram (serial numbers 319995 thru 342573 only), hydraulic system.....	2-1782
(Direct linear) valve bracket, jaw control.....	2-1298
(Direct linear) valve linkage, jaw control.....	2-1294
Direct linear valve (serial numbers 319995 thru 342573 only), jaw.....	2-1250
(Direct linear) valve-to-manifold block oil lines, jaw control.....	2-1513
(Direct linear) valve tubes and fittings, jaw control.....	2-1391
Drain line, hydraulic pump-to-speed gear assembly (reverser) seal.....	2-1369

E

Element, pump stroke control valve filter.....	2-1196
Expendable supplies and materials list.....	C-1
Extinguisher, fire.....	2-1851

F

Filter element, pump stroke control valve.....	2-1196
Filter, hydraulic oil.....	2-1698
Fire extinguisher.....	2-1851
Fire extinguisher mounting brackets.....	2-1852
Fire extinguisher equipment components.....	2-1851

G

Gages (non-electrical), weighing and measuring devices.....	2-1785
Guards (serial numbers 319995 thru 342573 only), backhoe dipperstick hose.....	2-1826

H

Handle and linkage, loader control valve.....	2-1324
Head end boom cylinder oil line, manifold block-to-.....	2-1565
Hoses and fittings, hydraulic earth drill.....	2-1855
Hydraulic accumulator charging.....	2-1194
Hydraulic accumulator oil line, hydraulic pump pressure line tee-to-.....	2-1384
Hydraulic and fluid systems.....	2-1189
Hydraulic earth drill auger.....	2-1866
Hydraulic earth drill bleed oil line.....	2-1550
Hydraulic earth drill boring head.....	2-1870

INDEX - CONTINUED

Subject	Page
H - CONTINUED	
Hydraulic earth drill hoses and fittings.....	2-1855
Hydraulic earth drill mounting adapter.....	2-1862
Hydraulic impactor and motor assembly	2-1893
Hydraulic impactor flow regulator	2-1237
Hydraulic impactor flow regulator-to-boom oil line (serial numbers 235786 thru 235999 only)	2-1499
Hydraulic impactor flow regulator-to-boom oil line (serial numbers 319995 thru 342573 only)	2-1505
Hydraulic impactor lines and fittings.....	2-1879
Hydraulic impactor mounting adapter.....	2-1883
Hydraulic impactor valve	2-1228
Hydraulic impactor valve oil line (serial numbers 235786 thru 235999 only), manifold-to-.....	2-1444
Hydraulic impactor valve oil line (serial numbers 319995 thru 342573 only), jaw direct linear valve-to-.....	2-1421
Hydraulic impactor working tools.....	2-1888
Hydraulic oil cooler hose (serial numbers 319995 thru 342573 only), hydraulic pump-to-.....	2-1338
Hydraulic oil cooler oil line (serial numbers 235786 thru 235999 only), hydraulic pump-to-.....	2-1342
Hydraulic oil cooler-to-clutch control valve oil line.....	2-1361
Hydraulic oil filter	2-1698
Hydraulic oil filter relief valve	2-1217
Hydraulic oil filter relief valve oil line, loader control valve-to-.....	2-1653
Hydraulic oil filter relief valve oil line (serial numbers 235786 thru 235999 only), manifold-to-.....	2-1450
Hydraulic oil filter relief valve oil line (serial numbers 319995 thru 342573 only), jaw direct linear valve-to-.....	2-1464
Hydraulic oil filter relief valve-to-clutch control valve adapter oil line.....	2-1346
Hydraulic pump inlet oil line, clutch control valve-to-.....	2-1352
Hydraulic pump pressure line tee-to-hydraulic accumulator oil line	2-1384
Hydraulic pump-to-hydraulic oil cooler hose (serial numbers 319995 thru 342573 only).....	2-1388
Hydraulic pump-to-hydraulic oil cooler oil line (serial numbers 235786 thru 235999 only)	2-1342
Hydraulic pump-to-pressure control valve oil line.....	2-1375
Hydraulic pump-to-speed gear assembly (reverser) seal drain line	2-1369
Hydraulic system	2-1189
Hydraulic system diagram (serial numbers 235786 thru 235999 only)	2-1779
Hydraulic system diagram (serial numbers 319995 thru 342573 only)	2-1782
Hydraulic system pressure release	2-1191
I	
Illustrated list of manufactured items.....	D-1
Impactor flow regulator, hydraulic.....	2-1237
Impactor valve, hydraulic.....	2-1228

INDEX - CONTINUED

Subject	Page
Indicator, air cleaner restriction	2-1792
Indicator, loader bucket level.....	2-1838

J

Jaw control (direct linear) valve bracket	2-1298
Jaw control (direct linear) valve linkage.....	2-1294
Jaw control (direct linear) valve-to-manifold block oil lines	2-1513
Jaw control (direct linear) valve tubes and fittings.....	2-1391
Jaw control valve oil lines (serial numbers 235786 thru 235999 only), manifold-to-	2-1456
Jaw control valve (serial numbers 235786 thru 235999 only)	2-1242
Jaw cylinder.....	2-1703
Jaw cylinder oil hose oil lines (serial numbers 235786 thru 235999 only), boom-to-	2-1532
Jaw cylinder oil hose oil lines (serial numbers 319995 thru 342573 only), boom-to-	2-1538
Jaw cylinder oil hoses.....	2-1544
Jaw direct linear valve oil line (serial numbers 319995 thru 342573 only), backhoe control valve-to-	2-1412
Jaw direct linear valve oil line (serial numbers 319995 thru 342573 only), pressure control valve-to-	2-1405
Jaw direct linear valve (serial numbers 319995 thru 342573 only)	2-1250
Jaw direct linear valve-to-backhoe control valve oil line (serial numbers 319995 thru 342573 only)	2-1436
Jaw direct linear valve-to-hydraulic impactor valve oil line (serial numbers 319995 thru 342573 only)	2-1421
Jaw direct linear valve-to-hydraulic oil filter relief valve oil line (serial numbers 319995 thru 342573 only).....	2-1464

L

Level indicator, loader bucket.....	2-1834
Levers and linkage (serial numbers 235786 thru 235999 only), backhoe control valve	2-1302
Levers and linkage (serial numbers 319995 thru 342573 only), backhoe control valve	2-1314
Lines and fittings, hydraulic impactor	2-1879
Linkage, backhoe bucket.....	2-1818
Linkage, jaw control (direct linear) valve	2-1294
Linkage, loader bucket	2-1844
Linkage, loader control valve handle and.....	2-1324
Linkage (serial numbers 235786 thru 235999 only), backhoe control valve levers and.....	2-1302
Linkage (serial numbers 319995 thru 342573 only), backhoe control valve levers and.....	2-1314
Loader boom cylinder head end oil lines, loader control valve-to-	2-1679
Loader boom cylinder rod end oil lines, loader control valve-to-.....	2-1688

INDEX - CONTINUED

Subject	Page
L - CONTINUED	
Loader boom cylinders	2-1770
Loader bucket.....	2-1833
Loader bucket cylinder head end oil lines, loader control valve-to.....	2-1661
Loader bucket cylinder rod end oil lines, loader control valve-to.....	2-1670
Loader bucket cylinders.....	2-1760
Loader bucket level indicator.....	2-1838
Loader bucket level indicator lubrication	2-1897
Loader bucket linkage	2-1844
Loader bucket support.....	2-1830
Loader control valve	2-1285
Loader control valve handle and linkage.....	2-1324
Loader control valve mounting bracket	2-1282
Loader control valve oil line, pressure control valve-to-	2-1647
Loader control valve-to-hydraulic oil filter relief valve oil line.....	2-1653
Loader control valve-to-loader boom cylinder head end oil lines	2-1679
Loader control valve-to-loader boom cylinder rod end oil lines.....	2-1688
Loader control valve-to-loader bucket cylinder head end oils lines.....	2-1661
Loader control valve-to-loader bucket cylinder rod end oil lines.....	2-1670
Lubrication, loader bucket lever indicator	2-1897

M

Maintenance allocation chart.....	B-1
Manifold block	2-1270
Manifold block oil lines, backhoe control valve-to-	2-1558
Manifold block oil lines, jaw control (direct linear) valve-to-	2-1513
Manifold block-to-boom bucket cylinder oil lines	2-1590
Manifold block-to-boom jaw control oil hoses (serial numbers 235786 thru 235999 only)	2-1522
Manifold block-to-boom jaw control oil tubes (serial numbers 319995 thru 342573 only)	2-1526
Manifold block-to-crowd cylinder oil lines (serial numbers 235786 thru 235999 only)	2-1570
Manifold block-to crowd cylinder oil lines (serial numbers 319995 thru 342573 only)	2-1578
Manifold block-to-head end boom cylinder oil line.....	2-1565
Manifold hydraulic impactor return oil line (serial numbers 235786 thru 235999 only), boom-to-.....	2-1483
Manifold oil line (serial numbers 235786 thru 235999 only), pressure control valve-to-.....	2-1400
Manifold oil lines (serial numbers 235786 thru 235999 only), backhoe control valve-to-.....	2-1429
Manifold-to-hydraulic impactor valve oil line (serial numbers 235786 thru 235999 only)	2-1444
Manifold-to-hydraulic oil filter relief valve oil line (serial numbers 235786 thru 235999 only)	2-1450
Manifold-to-jaw control valve oil lines (serial numbers 235786 thru 235999 only).....	2-1456

INDEX - CONTINUED

Subject	Page
M - CONTINUED	
Motor assembly, hydraulic, impactor, and.....	2-1893
Mounting adapter, hydraulic earth drill	2-1862
Mounting adapter, hydraulic impactor	2-1883
Mounting bracket, fire extinguisher	2-1852
Mounting bracket, loader control valve.....	2-1282

O

Oil filter, hydraulic.....	2-1698
Oil hoses, jaw cylinder.....	2-1544
Oil hoses (serial numbers 235786 thru 235999 only), manifold block-to-boom jaw control	2-1522
Oil line, clutch control valve-to-hydraulic pump inlet.....	2-1352
Oil line, hydraulic earth drill bleed.....	2-1550
Oil line, hydraulic oil filter relief valve-to-clutch control valve adapter	2-1346
Oil line, hydraulic oil cooler-to-clutch control valve.....	2-1361
Oil line, hydraulic pump pressure line tee-to-hydraulic accumulator	2-1384
Oil line, hydraulic pump-to-pressure control valve.....	2-1375
Oil line, loader control valve-to-hydraulic oil filter relief valve.....	2-1653
Oil line, manifold block-to-head end boom cylinder.....	2-1565
Oil line, pressure control valve-to-loader control valve.....	2-1647
Oil lines, backhoe control valve-to-manifold block	2-1558
Oil lines, backhoe control valve-to-backhoe stabilizer cylinder	2-1622
Oil lines, backhoe control valve-to-backhoe swing cylinder	2-1636
Oil line (serial numbers 285786 thru 235999 only), boom-to-manifold hydraulic impactor return.....	2-1483
Oil line (serial numbers 235786 thru 235999 only), hydraulic impactor flow regulator-to-boom.....	2-1499
Oil line (serial numbers 235786 thru 235999 only), hydraulic pump-to-hydraulic oil cooler.....	2-1342
Oil line (serial numbers 235786 thru 235999 only), manifold-to-hydraulic impactor valve	2-1444
Oil line (serial numbers 235786 thru 235999 only), manifold-to-hydraulic oil filter relief valve.....	2-1450
Oil line (serial numbers 235786 thru 235999 only), pressure control valve-to manifold.....	2-1400
Oil line (serial numbers 319995 thru 342573 only), backhoe control valve-to jaw direct linear valve.....	2-1412
Oil line (serial numbers 319995 thru 342573 only), boom-to-backhoe control valve hydraulic impactor return	2-1489
Oil line (serial numbers 319995 thru 342573 only), hydraulic impactor flow regulator-to-boom.....	2-1505
Oil line (serial numbers 319995 thru 342573 only), jaw direct linear valve-to-backhoe control valve	2-1436
Oil line (serial numbers 319995 thru 342573 only), jaw direct linear valve-to-hydraulic impactor valve.....	2-1421

INDEX - CONTINUED

Subject	Page
O - CONTINUED	
Oil line (serial numbers 319995 thru 342573 only), jaw direct linear valve-to-hydraulic oil filter relief valve	2-1464
Oil line (serial numbers 319995 thru 342573 only), pressure control valve-to-jaw direct linear valve.....	2-1405
Oil lines, jaw control (direct linear) valve-to-manifold block.....	2-1513
Oil lines, loader control valve-to-loader boom cylinder head end.....	2-1679
Oil lines, loader control valve-to-loader boom cylinder rod end.....	2-1688
Oil lines, loader control valve-to-loader bucket cylinder head end.....	2-1661
Oil lines, loader control valve-to-loader bucket cylinder rod end.....	2-1670
Oil lines, manifold block-to-boom bucket cylinder	2-1590
Oil lines (serial numbers 235786 thru 23599 only), backhoe control valve-to-manifold	2-1429
Oil lines (serial numbers 235786 thru 235999 only), boom-to-bucket cylinder.....	2-1598
Oil lines (serial numbers 235786 thru 235999 only), boom-to-jaw cylinder oil hose.....	2-1532
Oil lines (serial numbers 235786 thru 235999 only), manifold block-to-crowd cylinder.....	2-1570
Oil lines (serial numbers 235786 thru 235999 only), manifold-to-jaw control valve.....	2-1456
Oil lines (serial numbers 235786 thru 235999 only), quick coupler-to-boom	2-1472
Oil lines (serial numbers 319995 thru 342573 only), boom-to-bucket cylinder.....	2-1608
Oil lines (serial numbers 319995 thru 342573 only), boom-to-jaw cylinder oil hose.....	2-1538
Oil lines (serial numbers 319995 thru 342573 only), manifold block-to-crowd cylinder.....	2-1578
Oil lines (serial numbers 319995 thru 342573 only), quick coupler-to-boom	2-1477
Oil tubes (serial numbers 319995 thru 342573 only), manifold block-to-boom jaw control	2-1536

P

Parts Peculiar	2-1855
Preparation for storage or shipment.....	2-1897
Pressure control valve.....	2-1200
Pressure control valve oil line, hydraulic pump-to.....	2-1375
Pressure control valve-to-jaw direct linear valve oil line (serial numbers 319995 thru 342573 only)	2-1405
Pressure control valve-to-loader control valve oil line.....	2-1647
Pressure control valve-to-manifold oil line (serial numbers 235786 thru 235999 only).....	2-1400
Pressure release, hydraulic system.....	2-1191
Pump stroke control valve filter element	2-1196

INDEX - CONTINUED

Subject	Page
Q	
Quick coupler-to-boom oil lines (serial numbers 235786 thru 235999 only).....	2-1472
Quick coupler-to-boom oil lines (serial numbers 319995 thru 342573 only).....	2-1477
R	
References	A-1
Regulator, hydraulic impactor flow	2-1237
Relief valve, hydraulic oil filter	2-1217
Restriction Indicator, air cleaner.....	2-1792
S	
Speed gear assembly (reverser) seal drain line, hydraulic pump-to-	2-1369
Stroke control valve filter element, pump	2-1196
Support, loader bucket	2-1830
System, hydraulic	2-1189
T	
Tachometer	2-1785
Tachometer drive cable	2-1789
Teeth, backhoe bucket	2-1815
Torque limits.....	F-1
Tubes and fittings, jaw control (direct linear) valve	2-1391
V	
Valve, backhoe control	2-1260
Valve bracket, jaw control (direct linear)	2-1298
Valve, hydraulic impactor	2-1228
Valve, hydraulic oil filter relief.....	2-1217
Valve, loader control.....	2-1285
Valve, pressure control.....	2-1200
Valve (serial numbers 235786 thru 235999 only), jaw control.....	2-1242
Valve (serial numbers 319995 thru 342573 only), jaw direct linear.....	2-1250
W	
Working tools, hydraulic impactor	2-1888

By Order of the Secretary of the Army:

Official:

CARLE E. VUONO
General, United States Army
Chief of Staff

R. L. DILWORTH
Brigadier General United States Army
The Adjutant General

Distribution:

To be distributed in accordance with DA Form 12-25A. Unit Maintenance requirements for Tractor, Wheeled, Diesel with Loader Backhoe, Model JD 410.

☆U.S. GOVERNMENT PRINTING OFFICE: 1994 - 30-421 (03058)

THE METRIC SYSTEM AND EQUIVALENTS

LINEAR MEASURE

1 Centimeter = 10 Millimeters = 0.01 Meters = 0.3937 Inches
 1 Meter = 100 Centimeters = 1000 Millimeters = 39.37 Inches
 1 kilometer = 1000 Meters = 0.621 Miles

WEIGHTS

1 Gram = 0.001 Kilograms = 1000 Milligrams = 0.035 Ounces
 1 Kilogram = 1000 Grams = 2.2 Lb.
 1 Metric Ton = 1000 Kilograms = 1 Megagram = 1.1 Short Tons

LIQUID MEASURE

1 Milliliter = 0.001 Liters = 0.0338 Fluid Ounces
 1 Liter = 1000 Milliliters = 33.82 Fluid Ounces

SQUARE MEASURE

1 Sq. Centimeter = 100 Sq. Millimeters = 0.155 Sq. Inches
 1 Sq. Meter = 10,000 Sq. Centimeters = 10.76 Sq. Feet
 1 Sq. Kilometer = 1,000,000 Sq. Meters = 0.386 Sq. Miles

CUBIC MEASURE

1 Cu. Centimeter = 1000 Cu. Millimeters = 0.06 Cu. Inches
 1 Cu. Meter = 1,000,000 Cu. Centimeters = 35.31 Cu. Feet

TEMPERATURE

$5/9 (^{\circ}\text{F} - 32) = ^{\circ}\text{C}$
 212° Fahrenheit is equivalent to 100° Celsius
 90° Fahrenheit is equivalent to 32.2° Celsius
 32° Fahrenheit is equivalent to 0° Celsius
 $9/5 (^{\circ}\text{C} + 32) = ^{\circ}\text{F}$

APPROXIMATE CONVERSION FACTORS

TO CHANGE	TO	MULTIPLY BY
Inches	Centimeters	2.540
Feet	Meters	0.305
Yards	Meters	0.914
Miles	Kilometers	1.609
Square Inches	Square Centimeters	6.451
Square Feet	Square Meters	0.093
Square Yards	Square Meters	0.836
Square Miles	Square Kilometers	2.590
Acres	Square Hectometers	0.405
Cubic Feet	Cubic Meters	0.028
Cubic Yards	Cubic Meters	0.765
Fluid Ounces	Milliliters	29.573
Pints	Liters	0.473
Quarts	Liters	0.946
Gallons	Liters	3.785
Ounces	Grams	28.349
Pounds	Kilograms	0.454
Short Tons	Metric Tons	0.907
Pound-Feet	Newton-Meters	1.356
Pounds per Square Inch	Kilopascals	6.895
Miles per Gallon	Kilometers per Liter	0.425
Miles per Hour	Kilometers per Hour	1.609
TO CHANGE	TO	MULTIPLY BY
Centimeters	Inches	0.394
Meters	Feet	3.280
Meters	Yards	1.094
Kilometers	Miles	0.621
Square Centimeters	Square Inches	0.155
Square Meters	Square Feet	10.764
Square Meters	Square Yards	1.196
Square Kilometers	Square Miles	0.386
Square Hectometers	Acres	2.471
Cubic Meters	Cubic Feet	35.315
Cubic Meters	Cubic Yards	1.308
Milliliters	Fluid Ounces	0.034
Liters	Pints	2.113
Liters	Quarts	1.057
Liters	Gallons	0.264
Grams	Ounces	0.035
Kilograms	Pounds	2.205
Metric Tons	Short Tons	1.102
Newton-Meters	Pound-Feet	0.738
Kilopascals	Pounds per Square Inch	0.145
Kilometers per Liter	Miles per Gallon	2.354
Kilometers per Hour	Miles per Hour	0.621

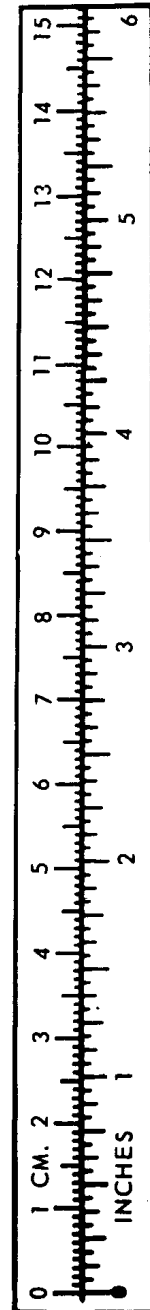

PIN: 062490-001