

WSM

WORKSHOP MANUAL **TRACTOR, ROTARY MOWER, FRONT LOADER**

**BX1860, BX2360, BX2660,
RCK48-18BX, RCK54-23BX,
RCK60B-23BX, RCK48P-18BX,
RCK54P-23BX, LA203, LA243**

Kubota

TO THE READER

This Workshop Manual has been prepared to provide servicing personnel with information on the mechanism, service and maintenance of KUBOTA Tractor BX1860, BX2360, BX2660, KUBOTA Rotary Mower RCK48-18BX, RCK54-23BX, RCK60B-23BX, RCK48P-18BX, RCK54P-23BX and KUBOTA Front Loader LA203, LA243. It is divided into three parts, "General", "Mechanism" and "Servicing" for each section.

■ General

Information on the tractor identification, the general precautions, maintenance check list, check and maintenance and special tools are described.

■ Mechanism

Information on the construction and function are included. This part should be understood before proceeding with troubleshooting, disassembling and servicing.

Refer to Diesel Engine / Tractor Mechanism Workshop Manual (Code No. 9Y021-01875 / 9Y021-18201) for the one which has not been described to this workshop manual.

■ Servicing

Information on the troubleshooting, servicing specification lists, tightening torque, checking and adjusting, disassembling and assembling and servicing which cover procedures, precautions, factory specifications and allowable limits.

All information illustrations and specifications contained in this manual are based on the latest product information available at the time of publication.

The right is reserved to make changes in all information at any time without notice.

August 2008

© KUBOTA Corporation 2008

SAFETY FIRST

This symbol, the industry’s “Safety Alert Symbol”, is used throughout this manual and on labels on the machine itself to warn of the possibility of personal injury. Read these instructions carefully.

It is essential that you read the instructions and safety regulations before you attempt to repair or use this unit.



DANGER : Indicates an imminently hazardous situation which, if not avoided, will result in death or serious injury.

WARNING : Indicates a potentially hazardous situation which, if not avoided, could result in death or serious injury.

CAUTION : Indicates a potentially hazardous situation which, if not avoided, may result in minor or moderate injury.

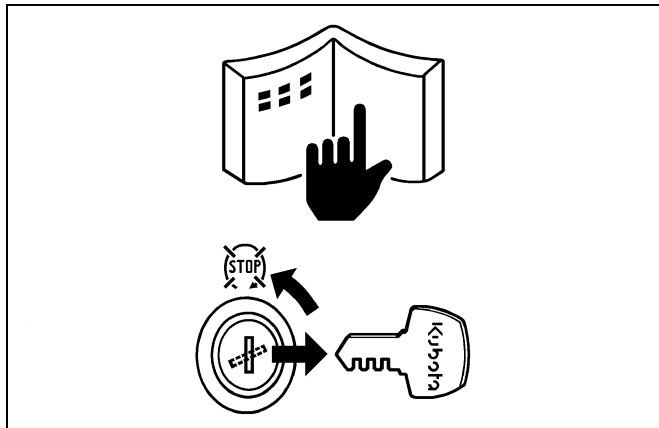

IMPORTANT : Indicates that equipment or property damage could result if instructions are not followed.

NOTE : Gives helpful information.

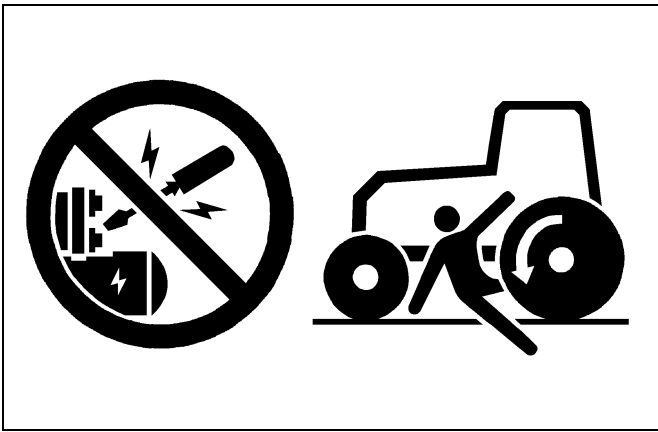

BEFORE SERVICING AND REPAIRING

- Read all instructions and safety instructions in this manual and on your machine safety decals.
- Clean the work area and machine.
- Park the machine on a firm and level ground, and set the parking brake.
- Lower the implement to the ground.
- Stop the engine, and remove the key.
- Disconnect the battery negative cable.
- Hang a “**DO NOT OPERATE**” tag in operator station.



SAFETY STARTING

- Do not start the engine by shorting across starter terminals or bypassing the safety start switch.
- Do not alter or remove any part of machine safety system.
- Before starting the engine, make sure that all shift levers are in neutral positions or in disengaged positions.
- Never start the engine while standing on ground. Start the engine only from operator's seat.

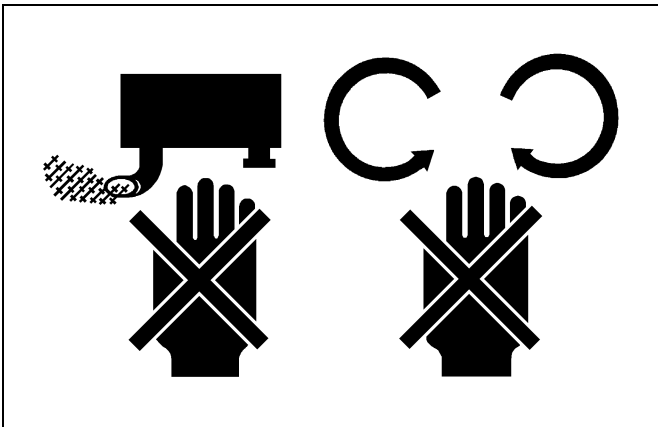

SAFETY WORKING

- Do not work on the machine while under the influence of alcohol, medication, or other substances or while fatigued.
- Wear close fitting clothing and safety equipment appropriate to the job.
- Use tools appropriate to the work. Makeshift tools, parts, and procedures are not recommended.
- When servicing is performed together by two or more persons, take care to perform all work safely.
- Do not work under the machine that is supported solely by a jack. Always support the machine by safety stands.
- Do not touch the rotating or hot parts while the engine is running.
- Never remove the radiator cap while the engine is running, or immediately after stopping. Otherwise, hot water will spout out from radiator. Only remove radiator cap when cool enough to touch with bare hands. Slowly loosen the cap to first stop to relieve pressure before removing completely.
- Escaping fluid (fuel or hydraulic oil) under pressure can penetrate the skin causing serious injury. Relieve pressure before disconnecting hydraulic or fuel lines. Tighten all connections before applying pressure.
- Do not open high-pressure fuel system. High-pressure fluid remaining in fuel lines can cause serious injury. Do not disconnect or attempt repair fuel lines, sensors, or any other components between the high-pressure fuel pump and injectors on engines with high pressure common rail fuel system.
- High voltage exceeding 100 V is generated in the ECU, and is applied to the injector. Pay sufficient caution to electric shock when performing work activities.

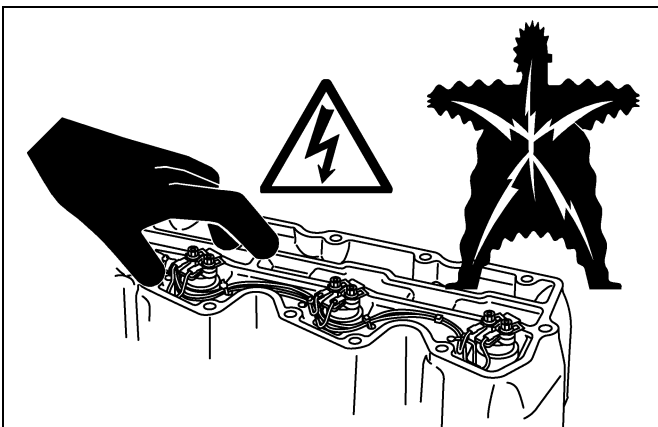
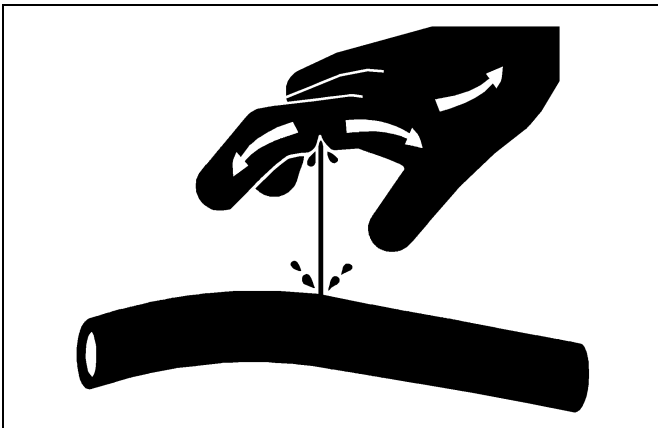

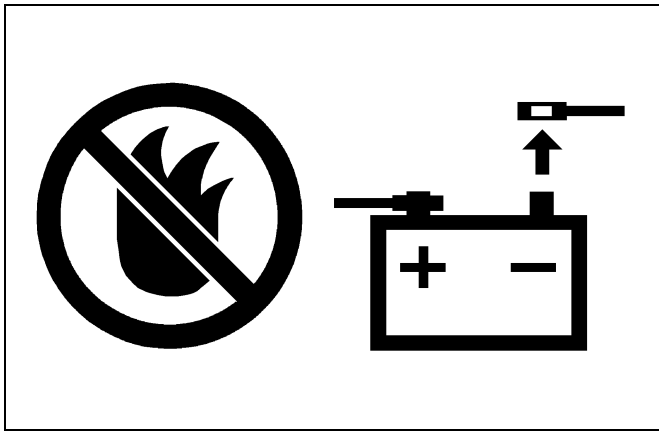

AVOID FIRES

- Fuel is extremely flammable and explosive under certain conditions. Do not smoke or allow flames or sparks in your working area.
- To avoid sparks from an accidental short circuit, always disconnect the battery negative cable first and connect it last.
- Battery gas can explode. Keep sparks and open flame away from the top of battery, especially when charging the battery.
- Make sure that no fuel has been spilled on the engine.

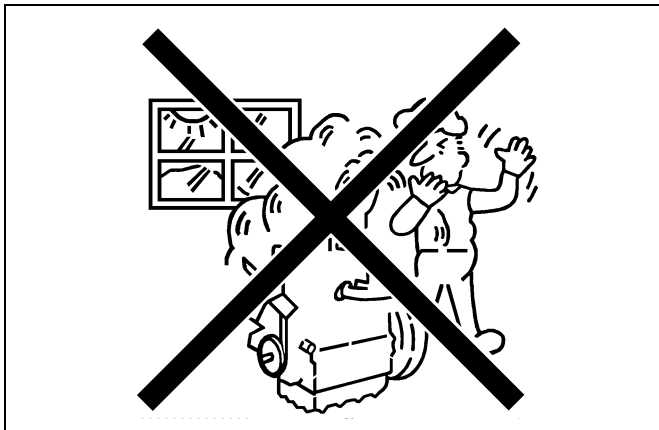

VENTILATE WORK AREA

- If the engine must be running to do some work, make sure the area is well ventilated. Never run the engine in a closed area. The exhaust gas contains poisonous carbon monoxide.

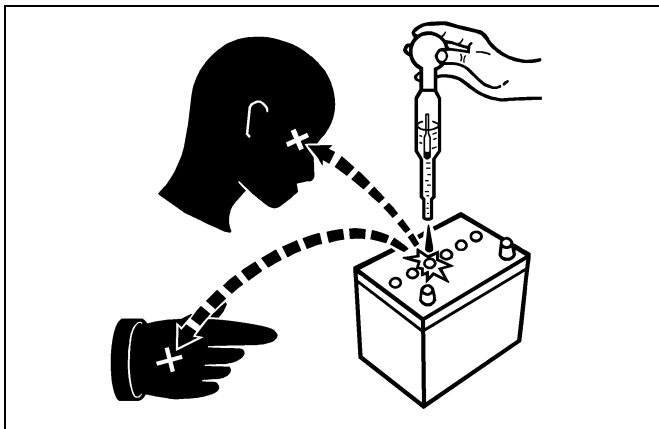

PREVENT ACID BURNS

- Sulfuric acid in battery electrolyte is poisonous. It is strong enough to burn skin, clothing and cause blindness if splashed into eyes. Keep electrolyte away from eyes, hands and clothing. If you spill electrolyte on yourself, flush with water, and get medical attention immediately.

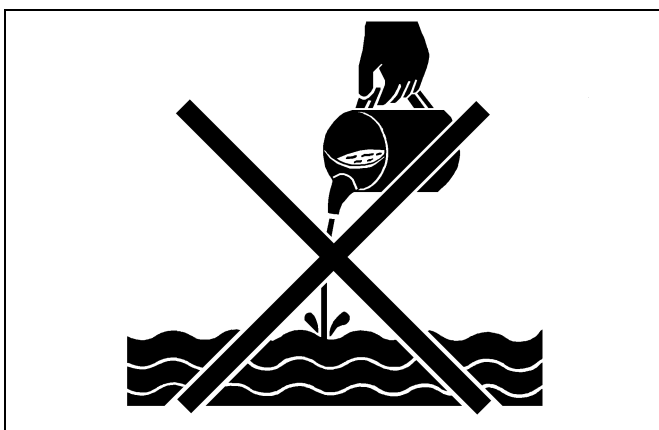

DISPOSE OF FLUIDS PROPERLY

- Do not pour fluids into the ground, down a drain, or into a stream, pond, or lake. Observe relevant environmental protection regulations when disposing of oil, fuel, coolant, electrolyte and other harmful waste.

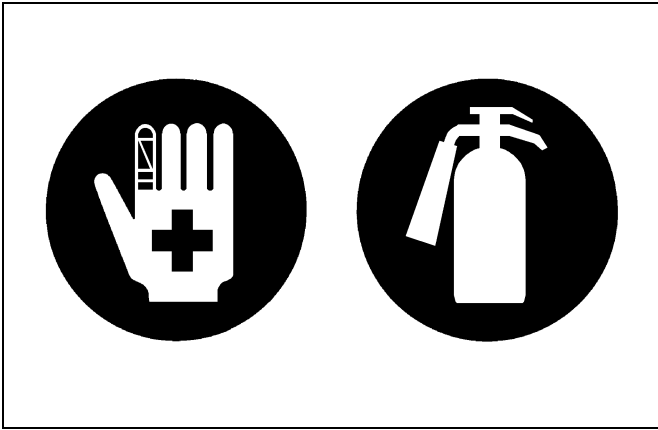
**PREPARE FOR EMERGENCIES**

- Keep a first aid kit and fire extinguisher handy at all times.
- Keep emergency numbers for doctors, ambulance service, hospital and fire department near your telephone.

SAFETY DECALS

The following safety decals are installed on the machine.

If a decal becomes damaged, illegible or is not on the machine, replace it. The decal part number is listed in the parts list.

(1) Part No. K2581-6557-1



WARNING
TO AVOID PERSONAL INJURY OR DEATH FROM ROLL-OVER:

1. Kubota recommends the use of a Roll-Over Protective Structures (ROPS) and seat belt in almost all applications.
 2. Remove the ROPS only when it substantially interferes with operation or itself presents a safety risk. (Examples include work in orchards and vineyards.)

ALWAYS REINSTALL IT BEFORE USING THE TRACTOR IN OTHER APPLICATIONS.
 3. Never use just the seat belt or just the ROPS. They must be used together. For further details, consult your Operator's Manual or your local dealer.

1AGAJAXAP041E

(2) Part No. K2581-6548-1

CAUTION

TO AVOID PERSONAL INJURY:

1. Read and understand the operator's manual before operation.
2. Before starting the engine, make sure that everyone is at a safe distance from the tractor and that the PTO is OFF.
3. Do not allow passengers on the tractor at any time.
4. Before allowing other people to use the tractor, have them read the operator's manual.
5. Check the tightness of all nuts and bolts regularly.
6. Keep all shields in place and stay away from all moving parts.
7. Slow down for turns, or rough roads.
8. On public roads use SMV emblem and hazard lights, if required by local traffic and safety regulations.
9. Pull only from the hitch.
10. Before dismounting, lower the implement to the ground, set the parking brake, stop the engine and remove the key.
11. Securely support tractor and implements before working underneath.

1AGAJAXAP042E

(5) Part No. K2581-6549-1

Diesel fuel only No fire

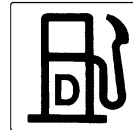

1AGAMAAAP2480

(3) Part No. 6C140-4746-1

WARNING

TO AVOID PERSONAL INJURY:

Do not modify or repair a ROPS because welding, grinding, drilling or cutting any portion may weaken the structure.

1AGAJAXAP045E

(4) Part No. K2581-6552-1

Do not put hands under the rear fender.

WARNING

TO AVOID PERSONAL INJURY: KEEP HANDS AWAY FROM PINCH POINTS OF LIFT ARMS.

1AGAJAXAP047E

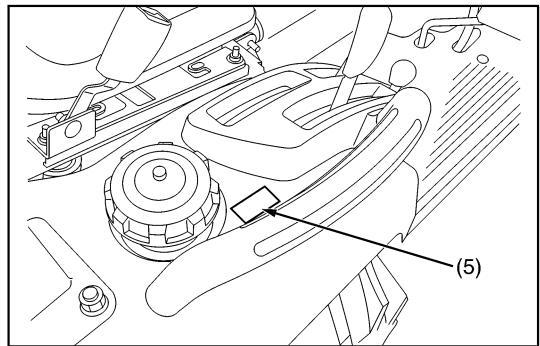
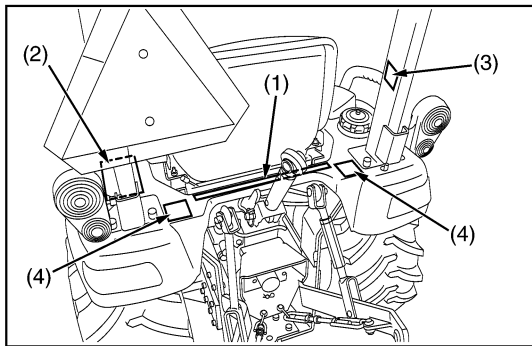

3TAAAFCP003A

(1) Part No. K2581-6554-1

	<p>⚠ WARNING</p>
	<p>TO AVOID PERSONAL INJURY:</p> <ol style="list-style-type: none"> 1. Keep PTO shield in place at all times. 2. Do not operate the PTO at speeds faster than the speed recommended by the implement manufacturer. 3. For trailing PTO-driven implements, set hitch at towing position. (see operator's manual)

1AGAJAXAP044E

(2) Part No. K2581-6555-1

<p>⚠ CAUTION</p>
<p>TO AVOID PERSONAL INJURY FROM SEPARATION:</p>  <p>DO NOT EXTEND LIFT ROD BEYOND THE GROOVE ON THE THREADED ROD.</p>

1AGAJAXAP043E

(3) Part No. K2581-6556-1

<p>⚠ WARNING</p>
<p>TO AVOID PERSONAL INJURY:</p> <ol style="list-style-type: none"> 1. Attach pulled or towed loads to the hitch only. 2. Use the 3-point hitch only with equipment designed for 3-point hitch usage.

1AGAJAXAP046E

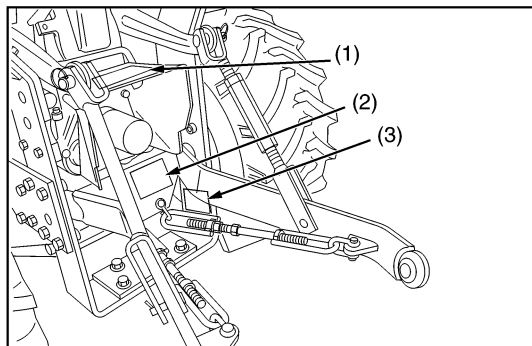

3TAAAKCP001A

(1) Part No. K2581-6541-1



⚠ DANGER
TO AVOID POSSIBLE INJURY OR DEATH FROM A MACHINE RUNAWAY:

1. Do not start engine by shorting across starter terminals or bypassing the safety start switch. Machine may start in gear and move if normal starting circuitry is bypassed.
2. Start engine only from operator's seat with transmission and PTO off. Never start engine while standing on the ground.

1AGA JAXAP048E

(2) Part No. K2581-6542-1

Do not touch hot surface like muffler, etc.

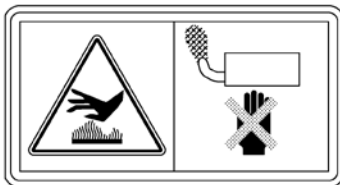

1AGA JAXAP050E

(3) Part No. K2581-6543-1

Stay clear of engine fan and fanbelt.



1AGA JAXAP052E

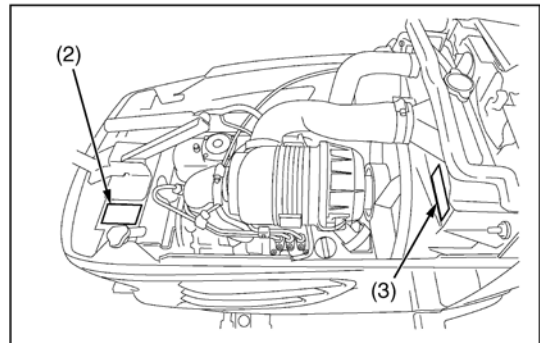
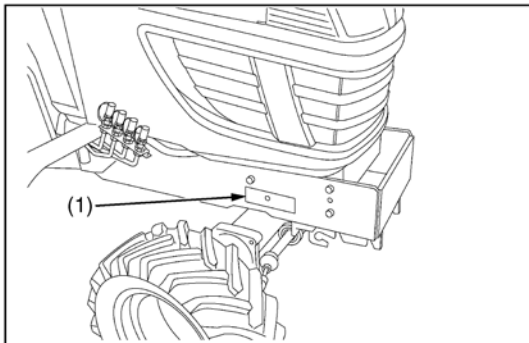

3TAAAAICP004A

(1) Part No. K2561-6115-1

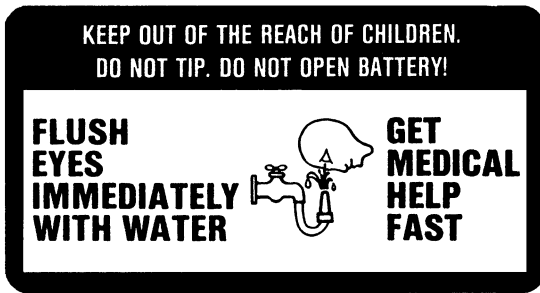

1AGAJAXAP053E

(2) Part No. K2561-6116-1

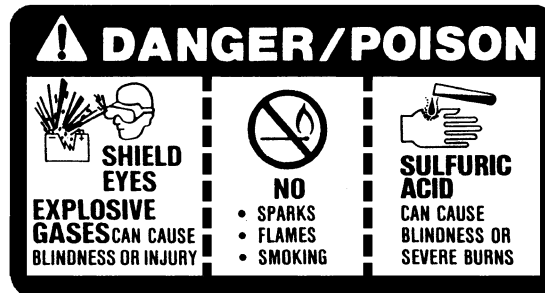

1AGAJAXAP054E

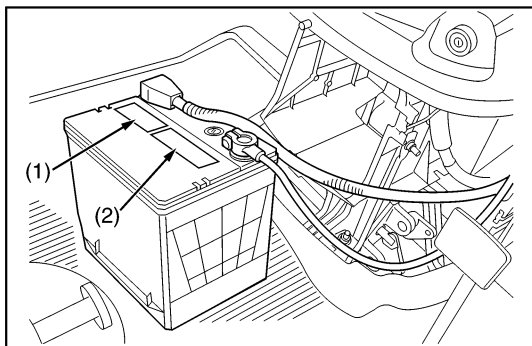

CARES FOR SAFETY ALERT LABELS

1. Always keep the labels clean and avoid damaging them.
If a label is dirty, clean it with soap and water. Then wipe it with a soft cloth.
Never use a solvent like thinner or acetone, which may erase letters or symbols.
2. When you wash the machine using a high pressure washer, do not pour high pressure water directly on any label to prevent it from peeling off.
3. If any label is damaged or missing, place an order with your dealer for replacement.
4. Before you affix a new label, completely clean the surface on which the label is placed. Wait until the surface is dry, and then affix the label in its place.
5. When you replace any part carrying a label, replace the label with a new one at the same time.

3TAAAAFCP006A

SPECIFICATIONS

Model		BX1860	BX2360	BX2660
PTO power		10.2 kW (13.7 HP)*	13.2 kW (17.7 HP)*	14.5 kW (19.5 HP)*
Engine	Maker	KUBOTA		
	Model	D722-E3-BX-2	D902-E3-BX-2	D1005-E3-BX
	Type	Indirect Injection, vertical, water-cooled, 4-cycle diesel		
	Number of cylinders	3		
	Bore and stroke	67 × 68 mm (2.64 × 2.68 in.)	72 × 73.6 mm (2.83 × 2.90 in.)	76 × 73.6 mm (2.99 × 2.90 in.)
	Total displacement	719 cm ³ (43.9 cu.in.)	898 cm ³ (54.8 cu.in.)	1001 cm ³ (61.1 cu.in.)
	Engine gross power	13.4 kW (18.0 HP)	17.1 kW (23.0 HP)	19.0 kW (25.5 HP)
	Rated revolution	3200 min ⁻¹ (rpm)		
	Maximum torque	44.9N·m (4.6kgf·m, 33.1 lbf·ft)	56.1 N·m (5.7kgf·m, 41.4lbf·ft)	60.2 N·m (6.1 kgf·m, 44.4 lbf·ft)
	Battery	12 V, RC : 62 min., CCA : 435 A	12 V, RC : 80 min., CCA : 535 A	
	Fuel	Diesel fuel No. 1 [below -10 °C (14 °F)], Diesel fuel No. 2 [above -10 °C (14 °F)]		
Capacities	Fuel tank	25 L (6.6 U.S.gals, 5.5 Imp.gals.)		
	Engine crankcase (with filter)	2.9 L (3.1 U.S.qts., 2.6 Imp.qts.)	3.1 L (3.3 U.S.qts., 2.7 Imp.qts.)	3.5 L (3.7 U.S.qts., 3.1 Imp.qts.)
	Engine coolant	2.5 L (2.6 U.S.qts., 2.2 Imp.qts.)	2.7 L (2.8 U.S.qts., 2.4 Imp.qts.)	2.9 L (3.1 U.S.qts., 2.6 Imp.qts.)
	Recovery tank	0.4 L (0.4 U.S.qts., 0.4 Imp.qts.)		
	Transmission case	11.6 L (3.06 U.S.gals, 2.55 Imp.gals.)		
Dimensions	Overall length (without 3P)	2035 mm (80.1 in.)	2120 mm (83.5 in.)	
	Overall length (with 3P)	2340 mm (92.1 in.)	2425 mm (95.5 in.)	
	Overall width (min. tread)	1145 mm (45.1 in.)		
	Overall height (with ROPS)	1760 mm (69.3in.)	1785 mm (70.3 in.)	
	Overall height (Top of seat)	1230 mm (48.4 in.)	1255 mm (49.4 in.)	1330 mm (52.4 in.)
	Wheel base	1340 mm (52.8 in.)	1400 mm (55.1 in.)	
	Minimum ground clearance	150 mm (5.9 in.)	175 mm (6.9 in.)	
	Tread	Front Rear	880 mm (34.6 in.)	910 mm (35.8 in.) 820 mm (32.2 in.)
Weight (with ROPS)		570 kg (1256.6 lbs)	585 kg (1289.7 lbs)	636 kg (1402.1 lbs)
Clutch		N / A		
Travelling system	Tires	Front Rear	16 × 7.50 – 8 24 × 12.00 – 12	18 × 8.50 – 10 26 × 12.00 – 12
	Steering	Hydrostatic type power steering		
	Transmission	Main: hydrostatic transmission, High-Low gear shift (2 forward and 2 reverse)		
	Brake	Wet disk type		
	Min. turning radius (without brake)	2.18 m (7.15 feet)	2.3 m (7.5 feet)	
Hydraulic system	Hydraulic control system	Directional control, auto-return lever system		
	Pump capacity	23.5 L/min. (6.2 U.S.gals./min., 5.2 Imp.gals./min.)		
	Three point hitch	SAE Category I		
	Max. lift force	At lift points 24 in. behind lift points	5390 N (1210 lbs)** 3040 N (680 lbs)**	
PTO	Rear PTO	PTO shaft	SAE 1-3/8, 6 splines	
		Revolution	1 speed (540 min ⁻¹ (rpm) at engine 3142 min ⁻¹ (rpm))	
	Mid	PTO shaft	USA No. 5 (KUBOTA 10-tooth) involute spline	
		Revolution	1 speed (2500 min ⁻¹ (rpm) at engine 3043 min ⁻¹ (rpm))	

NOTE: * Manufacture's estimate The company reserves the right to change the specifications without notice.

** See and check "IMPLEMENT LIMITATIONS".

TRAVELING SPEEDS

(At rated engine rpm)

Model		BX1860		BX2360 BX2660	
Tire size (Rear)		24 × 12.00 – 12		26 × 12.00 – 12	
	Range gear shift lever	km/h	mph	km/h	mph
Forward	Low	0 to 5.5	0 to 3.4	0 to 6.0	0 to 3.7
	High	0 to 12.0	0 to 7.5	0 to 13.0	0 to 8.1
Reverse	Low	0 to 4.5	0 to 2.5	0 to 4.5	0 to 2.8
	High	0 to 9.0	0 to 5.6	0 to 10.0	0 to 6.2

The company reserves the right to change the specifications without notice.

W1035065

DIMENSIONS

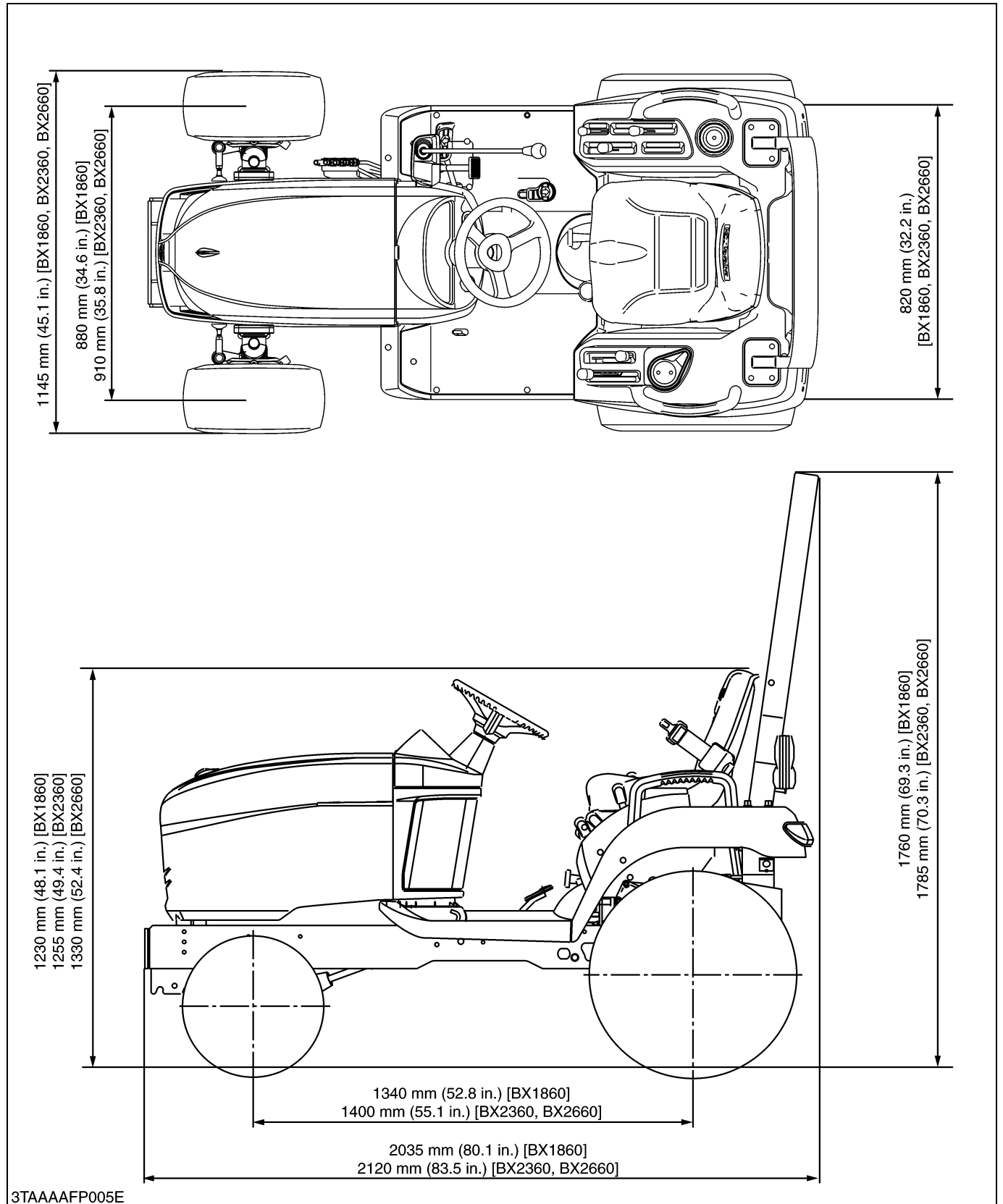

G GENERAL

GENERAL

CONTENTS

1. TRACTOR IDENTIFICATION	G-1
[1] SERIAL NUMBER.....	G-1
[2] CYLINDER NUMBER	G-1
2. GENERAL PRECAUTIONS	G-2
3. HANDLING PRECAUTIONS FOR ELECTRICAL PARTS AND WIRING..	G-3
[1] WIRING.....	G-3
[2] BATTERY.....	G-5
[3] FUSE.....	G-5
[4] CONNECTOR.....	G-5
[5] HANDLING OF CIRCUIT TESTER.....	G-6
4. LUBRICANTS, FUEL AND COOLANT	G-7
5. TIGHTENING TORQUES	G-9
[1] GENERAL USE SCREWS, BOLTS AND NUTS.....	G-9
[2] STUD BOLTS.....	G-9
[3] AMERICAN STANDARD SCREWS, BOLTS AND NUTS WITH UNC OR UNF THREADS	G-10
[4] PLUGS.....	G-10
6. MAINTENANCE CHECK LIST.....	G-11
7. CHECK AND MAINTENANCE	G-12
[1] DAILY CHECK	G-12
[2] CHECK POINTS OF INITIAL 50 HOURS.....	G-13
[3] CHECK POINTS OF EVERY 50 HOURS.....	G-15
[4] CHECK POINTS OF EVERY 100 HOURS.....	G-17
[5] CHECK POINTS OF EVERY 200 HOURS.....	G-22
[6] CHECK POINTS OF EVERY 400 HOURS.....	G-24
[7] CHECK POINT OF EVERY 500 HOURS	G-25
[8] CHECK POINT OF EVERY 800 HOURS	G-25
[9] CHECK POINT OF EVERY 1500 HOURS	G-25
[10]CHECK POINT OF EVERY 3000 HOURS	G-25
[11]CHECK POINT OF EVERY 1 YEAR.....	G-25
[12]CHECK POINTS OF EVERY 2 YEARS.....	G-26
[13]OTHERS	G-30
8. SPECIAL TOOLS.....	G-32
[1] SPECIAL TOOLS FOR ENGINE	G-32
[2] SPECIAL TOOLS FOR TRACTOR.....	G-37
9. TIRES.....	G-41
[1] TIRE PRESSURE	G-41
[2] WHEEL TREAD	G-42
(1) Front Wheels.....	G-42
(2) Rear Wheels	G-43
[3] BALLAST	G-44
(1) Front Ballast.....	G-44
(2) Rear Ballast	G-45
10. IMPLEMENT LIMITATIONS.....	G-46

1. TRACTOR IDENTIFICATION

[1] SERIAL NUMBER

When contacting your local KUBOTA distributor, always specify engine serial number, tractor serial number and hour meter reading.

- (1) Tractor Identification Plate
- (2) Tractor Serial Number
- (3) Engine Serial Number
- (4) Hour Meter

W1010590

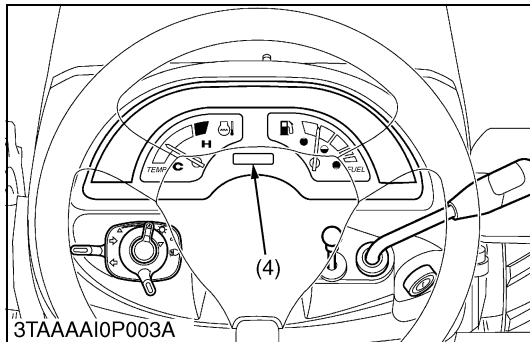
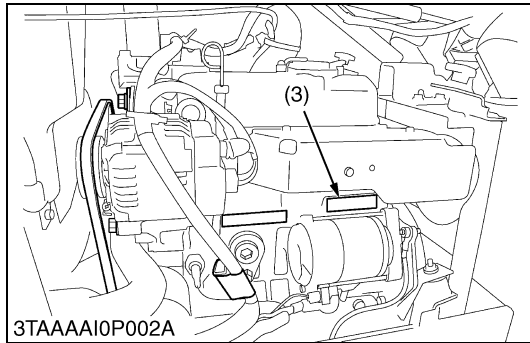
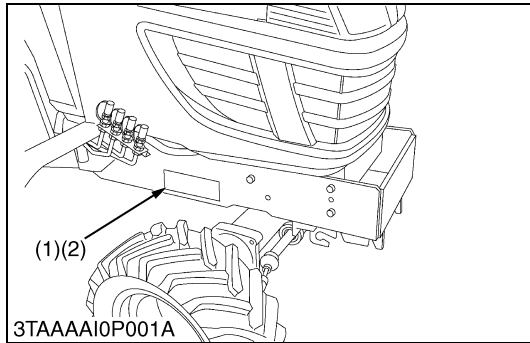

[2] CYLINDER NUMBER

The cylinder numbers of KUBOTA diesel engine are designated as shown in the figure.

The sequence of cylinder numbers is given as No.1, No.2 and No.3 starting from the gear case side.

W1011077

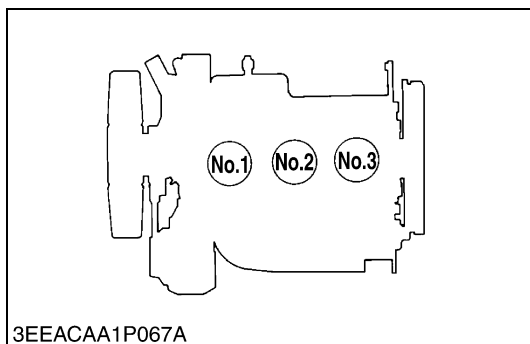

2. GENERAL PRECAUTIONS

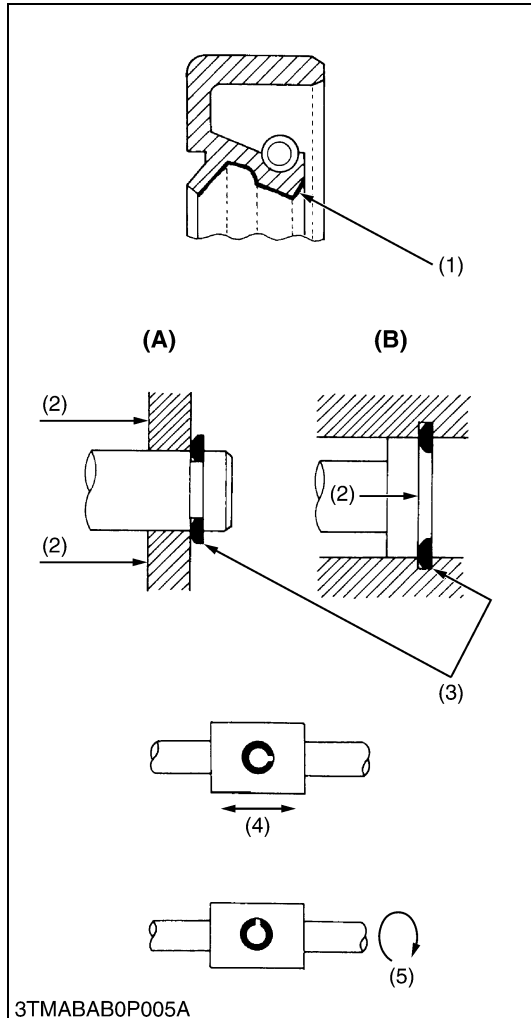

- During disassembly, carefully arrange removed parts in a clean area to prevent confusion later. Screws, bolts and nuts should be installed in their original position to prevent reassembly errors.
- When special tools are required, use KUBOTA genuine special tools. Special tools which are not frequently used should be made according to the drawings provided.
- Before disassembling or servicing electrical wires, always disconnect the ground cable from the battery first.
- Remove oil and dirt from parts before measuring.
- Use only KUBOTA genuine parts for parts replacement to maintain machine performance and to assure safety.
- Gaskets and O-rings must be replaced during reassembly. Apply grease to new O-rings or oil seals before assembling. See the figure left side.
- When reassembling external snap rings or internal snap rings, they must be positioned so that sharp edge faces against the direction from which a force is applied. See the figure left side.
- When inserting spring pins, their splits must face the direction from which a force is applied. See the figure left side.
- To prevent damage to the hydraulic system, use only specified fluid or equivalent.

- (1) Grease
- (2) Force
- (3) Sharp Edge
- (4) Axial Force
- (5) Rotating Movement

- (A) External Snap Ring
- (B) Internal Snap Ring

W10109040

3. HANDLING PRECAUTIONS FOR ELECTRICAL PARTS AND WIRING

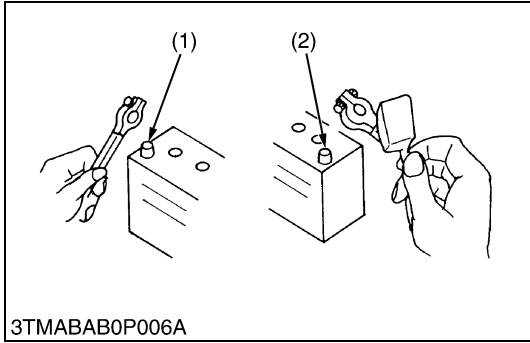

3TMABAB0P006A

To ensure safety and prevent damage to the machine and surrounding equipment, heed the following precautions in handling electrical parts and wiring.

■ IMPORTANT

- Check electrical wiring for damage and loosened connection every year. To this end, educate the customer to do his or her own check and at the same time recommend the dealer to perform periodic check for a fee.
- Do not attempt to modify or remodel any electrical parts and wiring.
- When removing the battery cables, disconnect the negative cable first. When installing the battery cables, connect the positive cable first.

- (1) Negative Terminal (2) Positive Terminal

W10111140

[1] WIRING

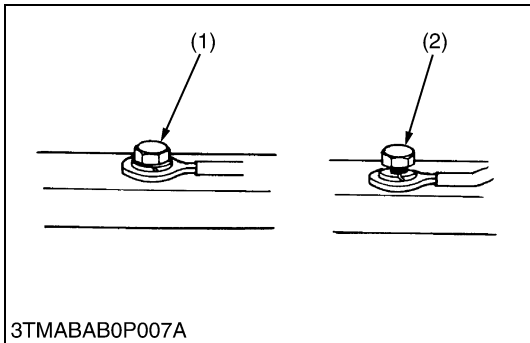

3TMABAB0P007A

- Securely tighten wiring terminals.

- (1) Correct (Securely Tighten) (2) Incorrect (Loosening Leads to Faulty Contact)

W10112160

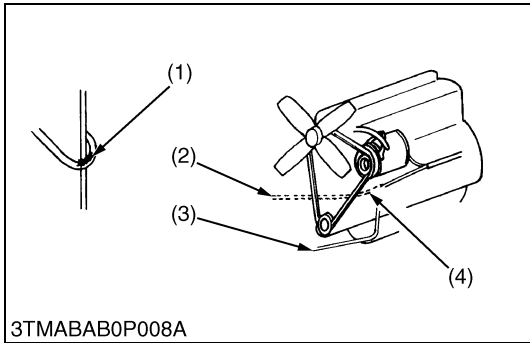

3TMABAB0P008A

- Do not let wiring contact dangerous part.

- (1) Dangerous Part (2) Wiring (Incorrect) (3) Wiring (Correct) (4) Dangerous Part

W10113130

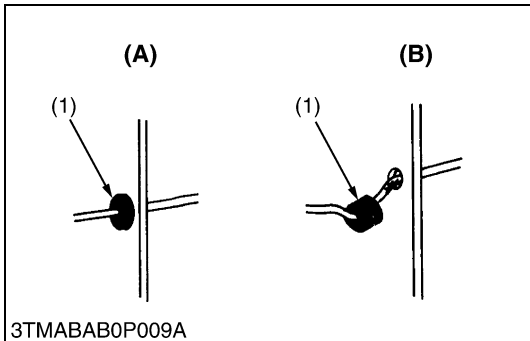

3TMABAB0P009A

- Securely insert grommet.

- (1) Grommet (A) Correct (B) Incorrect

W10113880

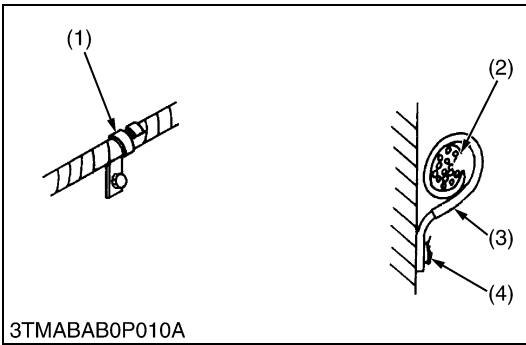

- Securely clamp, being careful not to damage wiring.

- (1) Clamp
 - Wind Clamp Spirally
- (2) Wire Harness
- (3) Clamp
- (4) Welding Dent

W10114580

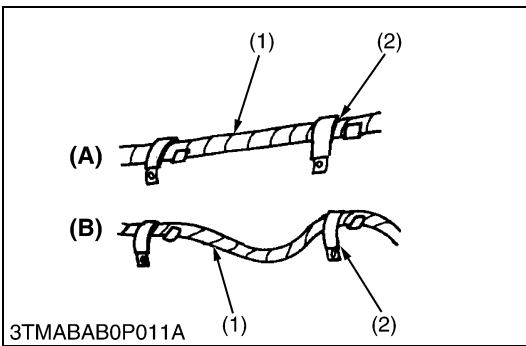

- Clamp wiring so that there is no twist, unnecessary sag, or excessive tension, except for movable part, where sag be required.

- (1) Wiring
- (2) Clamp
- (A) Correct
- (B) Incorrect

W10115870

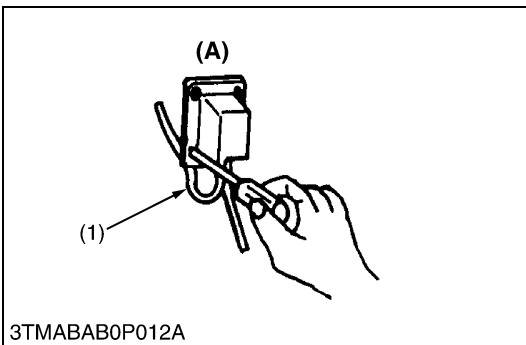

- In installing a part, take care not to get wiring caught by it.

- (1) Wiring
- (A) Incorrect

W10116700

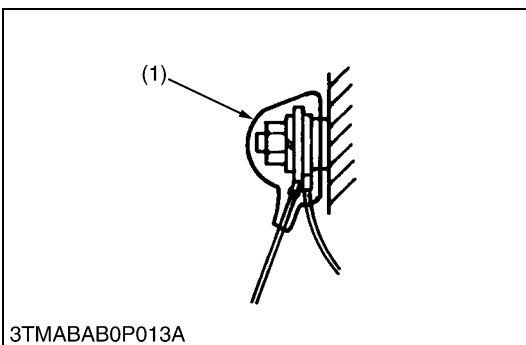

- After installing wiring, check protection of terminals and clamped condition of wiring, only connect battery.

- (1) Cover
 - Securely Install Cover

W10117350

[2] BATTERY

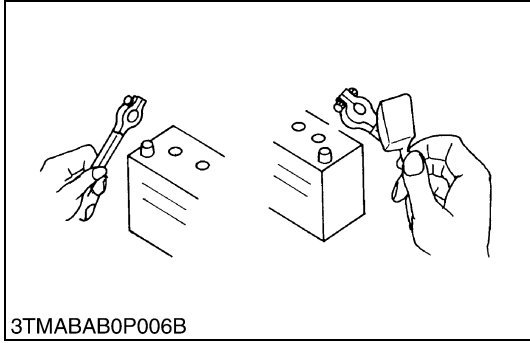

- Take care not to confuse positive and negative terminal posts.
- When removing battery cables, disconnect negative cable first. When installing battery cables, check for polarity and connect positive cable first.
- Do not install any battery with capacity other than is specified (Ah).
- After connecting cables to battery terminal posts, apply high temperature grease to them and securely install terminal covers on them.
- Do not allow dirt and dust to collect on battery.

CAUTION

- Take care not to let battery liquid spill on your skin and clothes. If contaminated, wash it off with water immediately.
- Before recharging the battery, remove it from the machine.
- Before recharging, remove cell caps.
- Do recharging in a well-ventilated place where there is no open flame nearby, as hydrogen gas and oxygen are formed.

W10118160

[3] FUSE

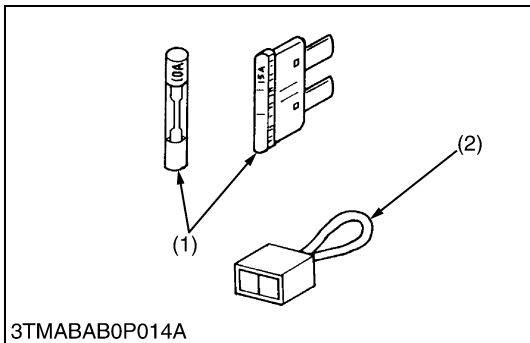

- Use fuses with specified capacity. Neither too large or small capacity fuse is acceptable.
- Never use steel or copper wire in place of fuse.
- Do not install working light, radio set, etc. on machine which is not provided with reserve power supply.
- Do not install accessories if fuse capacity of reserve power supply is exceeded.

(1) Fuse

(2) Slow Blow Fuse

W10120920

[4] CONNECTOR

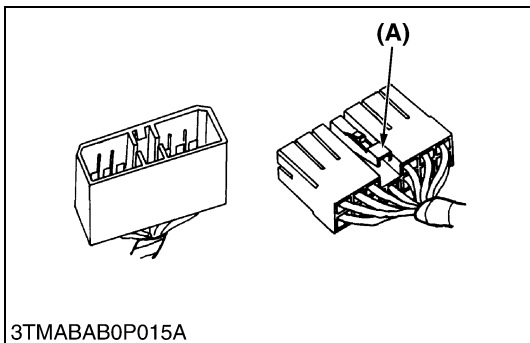

- For connector with lock, push lock to separate.

(A) Push

W10122110

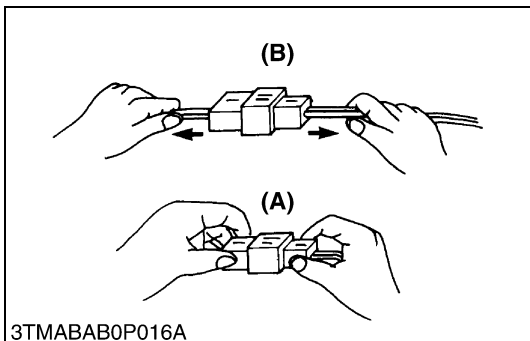

- In separating connectors, do not pull wire harnesses.
- Hold connector bodies to separate.

(A) Correct

(B) Incorrect

W10122720

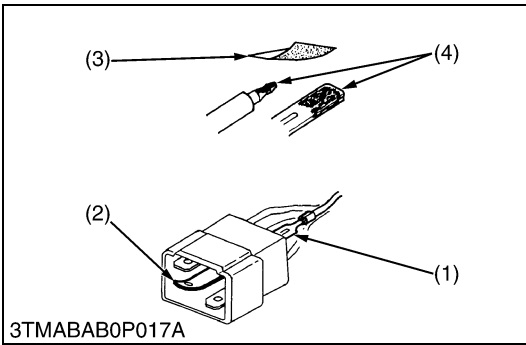

- Use sandpaper to remove rust from terminals.
- Repair deformed terminal. Make certain there is no terminal being exposed or displaced.

(1) Exposed Terminal (3) Sandpaper
 (2) Deformed Terminal (4) Rust

W10123460

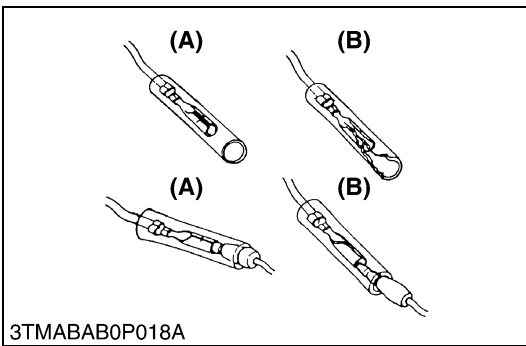

- Make certain that there is no female connector being too open.

(A) Correct (B) Incorrect

W10124300

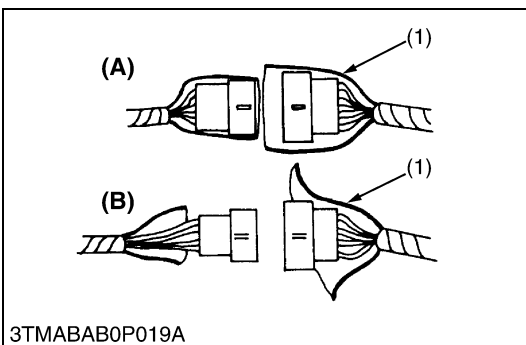

- Make certain plastic cover is large enough to cover whole connector.

(1) Cover (A) Correct (B) Incorrect

W10125190

[5] HANDLING OF CIRCUIT TESTER

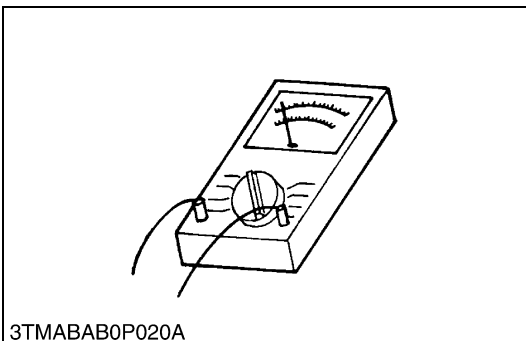

- Use tester correctly following manual provided with tester.
- Check for polarity and range.

W10126840

4. LUBRICANTS, FUEL AND COOLANT

No.	Place	Capacity			Lubricants, fuel and coolant
		BX1860	BX2360	BX2660	
1	Fuel tank	25.0 L 6.6 U.S.gals 5.5 Imp.gals			No. 2-D diesel fuel No. 1-D diesel fuel if temperature is below -10 °C (14 °F)
2	Cooling system with recovery tank	2.9 L 3.1 U.S.qts 2.6 Imp.qts	3.1 L 3.3 U.S.qts 2.7 Imp.qts	3.3 L 3.5 U.S.qts 2.9 Imp.qts	Fresh clean water with anti-freeze
3	Engine crankcase	2.9 L 3.1 U.S.qts 2.6 Imp.qts	3.1 L 3.3 U.S.qts 2.7 Imp.qts	3.5 L 3.7 U.S.qts 3.1 Imp.qts	Engine oil : API Service Classification CF or better Below 0 °C (32 °F) : SAE10W, 10W-30 or 15W-40 0 to 25 °C (32 to 77 °F): SAE20, 10W-30 or 15W-40 Above 25 °C (77 °F): SAE30, 10W-30 or 15W-40
4	Transmission case	11.6 L 3.1 U.S.gals 2.6 Imp.gals			KUBOTA SUPER UDT fluid*
5	Front axle case	2.3 L 2.4 U.S.qts 2.0 Imp.qts	4.7 L 5.0 U.S.qts 4.1 Imp.qts		KUBOTA SUPER UDT fluid or SAE80, SAE90 gear oil
Greasing					
	Place	No. of greasing point		Capacity	Type of grease
6	Battery terminal	2		Moderate amount	Multipurpose type Grease
7	Speed control pedal	1		Until grease overflows	NLGI-2 or NLGI-1 (GC-LG)

* KUBOTA original transmission hydraulic fluid.

■ **NOTE**

● **Engine Oil :**

- Oil used in the engine should have an American Petroleum Institute (API) service classification and Proper SAE Engine Oil according to the ambient temperature as shown above.
- With the emission control now in effect, the CF-4 and CG-4 lubricating oils have been developed for use of a low-sulfur fuel on on-road vehicle engines. When an off-road vehicle engine runs on a high-sulfur fuel, it is advisable to employ the “CF or better” lubricating oil with a high Total Base Number (TBN). **If the “CF-4 or CG-4, CH-4 or CI-4” lubricating oil is used with a high-sulfur fuel, change the lubricating oil at shorter intervals. (approximately half)**
- Lubricating oil recommended when a low-sulfur or high-sulfur fuel is employed.

○ : Recommendable X : Not Recommendable

Lubricating oil class	Fuel		Remark
	Low-sulfur	High-sulfur	
CF	○	○	TBN ≥ 10
CF-4	○☆	X	
CG-4	○☆	X	
CH-4	○☆	X	
CI-4	○	X	

- ☆ Class CF-4, CG-4 and CH-4 engine oils cannot be used on EGR (Exhaust Gas Re-circulation) type engines.
- The CJ-4 engine oil is intended for DPF (Diesel Particulate Filter) type engines, and cannot be used on this tractor.

● **Fuel :**

- Cetane number of 45 minimum. Cetane number greater than 50 is preferred, especially for temperatures below – 20 °C (–4 °F) or elevations above 1500 m (5000 ft).
- If diesel fuel with sulfur content greater than 0.5 % sulfur content is used, reduce the service interval for engine oil and filter by 50 %.
- Do not use diesel fuel with sulfur content greater than 1.0 %.
- Diesel fuels specified to EN 590 or ASTM D975 are recommended.
- No. 2-D is distillate fuel of lower volatility for engines in industrial and heavy mobile service. (SAE J313 JUN87)
- Since this engine adopts EPA Tier 4 and Interim Tier 4 standards, the use of low sulfur fuel or ultra low sulfur fuel is mandatory in EPA regulated area (North America). Therefore, please use No. 2-D S500 or S15 diesel fuel as an alternative to No. 2-D, or use No. 1-D S500 or S15 diesel fuel as an alternative to No. 1-D if outside air temperature is below –10 °C (14 °F)



● **Transmission Oil :**

- The oil used to lubricate the transmission is also used as hydraulic fluid. To insure proper operation of the hydraulic system and to complete lubrication of the transmission, it is important that a multi-grade transmission fluid is used in this system. We recommend the use of **KUBOTA UDT or SUPER UDT fluid** for optimum protection and performance.
Do not mix different brands together.
- Indicated capacities of water and oil are manufacture’s estimate.

5. TIGHTENING TORQUES

[1] GENERAL USE SCREWS, BOLTS AND NUTS

Screws, bolts and nuts whose tightening torques are not specified in this Workshop Manual should be tightened according to the table below.

Indication on top of bolt	 No-grade or 4T						 7T						 9T		
Material of bolt	SS400, S20C						S43C, S48C						SCr435, SCM435		
Material of opponent part	Ordinariness			Aluminum			Ordinariness			Aluminum			Ordinariness		
Unit															
Diameter	N-m	kgf-m	lbf-ft	N-m	kgf-m	lbf-ft	N-m	kgf-m	lbf-ft	N-m	kgf-m	lbf-ft	N-m	kgf-m	lbf-ft
M6 (6 mm, 0.24 in.)	7.9 to 9.3	0.80 to 0.95	5.8 to 6.8	7.9 to 8.8	0.80 to 0.90	5.8 to 6.5	9.81 to 11.2	1.00 to 1.15	7.24 to 8.31	7.9 to 8.8	0.80 to 0.90	5.8 to 6.5	12.3 to 14.2	1.25 to 1.45	9.05 to 10.4
M8 (8 mm, 0.31 in.)	18 to 20	1.8 to 2.1	13 to 15	17 to 19	1.7 to 2.0	13 to 14	24 to 27	2.4 to 2.8	18 to 20	18 to 20	1.8 to 2.1	13 to 15	30 to 34	3.0 to 3.5	22 to 25
M10 (10 mm, 0.39 in.)	40 to 45	4.0 to 4.6	29 to 33	32 to 34	3.2 to 3.5	24 to 25	48 to 55	4.9 to 5.7	36 to 41	40 to 44	4.0 to 4.5	29 to 32	61 to 70	6.2 to 7.2	45 to 52
M12 (12 mm, 0.47 in.)	63 to 72	6.4 to 7.4	47 to 53	-	-	-	78 to 90	7.9 to 9.2	58 to 66	63 to 72	6.4 to 7.4	47 to 53	103 to 117	10.5 to 12.0	76.0 to 86.7
M14 (14 mm, 0.55 in.)	108 to 125	11.0 to 12.8	79.6 to 92.5	-	-	-	124 to 147	12.6 to 15.0	91.2 to 108	-	-	-	167 to 196	17.0 to 20.0	123 to 144
M16 (16 mm, 0.63 in.)	167 to 191	17.0 to 19.5	123 to 141	-	-	-	197 to 225	20.0 to 23.0	145 to 166	-	-	-	260 to 304	26.5 to 31.0	192 to 224
M18 (18 mm, 0.71 in.)	246 to 284	25.0 to 29.0	181 to 209	-	-	-	275 to 318	28.0 to 32.5	203 to 235	-	-	-	344 to 402	35.0 to 41.0	254 to 296
M20 (20 mm, 0.79 in.)	334 to 392	34.0 to 40.0	246 to 289	-	-	-	368 to 431	37.5 to 44.0	272 to 318	-	-	-	491 to 568	50.0 to 58.0	362 to 419



W1034542

[2] STUD BOLTS

Material of opponent part	Ordinariness			Aluminum		
Unit						
Diameter	N-m	kgf-m	lbf-ft	N-m	kgf-m	lbf-ft
M8 (8 mm, 0.31 in.)	12 to 15	1.2 to 1.6	8.7 to 11	8.9 to 11	0.90 to 1.2	6.5 to 8.6
M10 (10 mm, 0.39 in.)	25 to 31	2.5 to 3.2	18 to 23	20 to 25	2.0 to 2.6	15 to 18
M12 (12 mm, 0.47 in.)	29.5 to 49.0	3.0 to 5.0	21.7 to 36.1	31.4	3.2	23.1

W1048139

[3] AMERICAN STANDARD SCREWS, BOLTS AND NUTS WITH UNC OR UNF THREADS

Grade	SAE GR.5 			SAE GR.8 			
	Unit	N·m	kgf·m	lbf·ft	N·m	kgf·m	lbf·ft
Nominal Diameter							
5/16		23.1 to 27.7	2.35 to 2.83	17.0 to 20.5	32.6 to 39.3	3.32 to 4.00	24.0 to 29.0
3/8		48 to 56	4.9 to 5.8	35.0 to 42.0	61.1 to 73.2	6.23 to 7.46	45.0 to 54.0
1/2		109 to 130	11.1 to 13.2	80.0 to 96.0	149.2 to 178.9	15.21 to 18.24	110.0 to 132.0
9/16		149.2 to 178.9	15.21 to 18.24	110.0 to 132.0	217.0 to 260.3	22.12 to 26.54	160.0 to 192.0
5/8		203.4 to 244	20.74 to 24.88	150.0 to 180.0	298.3 to 357.9	30.42 to 36.49	220.0 to 264.0

W1022485

[4] PLUGS

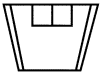
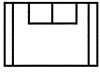
Shape	Size	Material of opponent part					
		Ordinariness			Aluminum		
		N·m	kgf·m	lbf·ft	N·m	kgf·m	lbf·ft
Tapered screw 	R1/8	13 to 21	1.3 to 2.2	9.4 to 15	13 to 21	1.3 to 2.0	9.4 to 15
	R1/4	25 to 44	2.5 to 4.5	18 to 32	25 to 34	2.5 to 3.5	18 to 25
Straight screw 	G1/4	25 to 34	2.5 to 3.5	18 to 25	–	–	–
	G3/8	62 to 82	6.3 to 8.4	46 to 60	–	–	–
	G1/2	49 to 88	5.0 to 9.0	37 to 65	–	–	–

000001666E

6. MAINTENANCE CHECK LIST

No.	Item	Period	Service Interval													Since then	Impor- tant	Refer- ence page	
			50	100	150	200	250	300	350	400	450	500	550	600	650				700
1	Engine oil	Change	★			☆				☆				☆		every 200 Hr		G-13	
2	Engine oil filter	Replace	★			☆				☆				☆		every 200 Hr		G-13	
3	Transmission oil filter	Replace	★			☆				☆				☆		every 200 Hr		G-14	
4	Transmission fluid	Change								☆						every 400 Hr		G-24	
5	Transmission strainer	Clean	★							☆						every 400 Hr		G-14	
6	Front axle case oil	Change								☆						every 400 Hr		G-24	
7	Front axle pivot	Adjust								☆						every 400 Hr		G-24	
8	Engine start system	Check	☆	☆	☆	☆	☆	☆	☆	☆	☆	☆	☆	☆	☆	every 50 Hr		G-15	
9	Greasing	—	☆	☆	☆	☆	☆	☆	☆	☆	☆	☆	☆	☆	☆	every 50 Hr		G-16	
10	Wheel bolt torque	Check	☆	☆	☆	☆	☆	☆	☆	☆	☆	☆	☆	☆	☆	every 50 Hr		G-16	
11	Battery condition	Check		☆		☆		☆		☆		☆		☆		every 100 Hr	*4	G-17	
12	Air cleaner element	Clean		☆		☆		☆		☆		☆		☆		every 100 Hr	*1	@	G-19
		Replace														every 1 year	*2		G-25
13	Fuel filter element	Check		☆		☆		☆		☆		☆		☆		every 100 Hr		@	G-20
		Replace									☆					every 500 Hr			G-25
14	Fan belt	Adjust		☆		☆		☆		☆		☆		☆		every 100 Hr		G-20	
15	HST neutral spring	Adjust		☆		☆		☆		☆		☆		☆		every 100 Hr		G-21	
16	Brake	Adjust		☆		☆		☆		☆		☆		☆		every 100 Hr		G-22	
17	Radiator hose and clamp	Check				☆				☆				☆		every 200 Hr		G-22	
		Replace														every 2 years		G-26	
18	Power steering oil line	Check				☆				☆				☆		every 200 Hr		G-23	
		Replace														every 2 years		G-26	
19	Fuel line	Check		☆		☆		☆		☆		☆		☆		every 100 Hr		@	G-20
		Replace														every 2 years			G-26
20	Intake air line	Check				☆				☆				☆		every 200 Hr		@	G-23
		Replace														every 2 years	*3		G-26
21	Toe-in	Adjust				☆				☆				☆		every 200 Hr		G-23	
22	Engine valve clearance	Adjust														every 800 Hr		1-S12	
23	Fuel injection nozzle injection pressure	Check														every 1500 Hr	@	1-S24	
24	Injection pump	Check														every 3000 Hr	@	1-S23	
25	Cooling system	Flush														every 2 years		G-27	
26	Coolant	Change														every 2 years		G-27	
27	Fuel system	Bleed																G-30	
28	Fuse	Replace														Service as required		G-30	
29	Light bulb	Replace																G-31	

■ IMPORTANT

- The jobs indicated by ★ must be done after the first 50 hours of operation.
- *1 : Air cleaner should be cleaned more often in dusty conditions than in normal conditions.
- *2 : Every year or every 6 times of cleaning.
- *3 : Replace only if necessary.
- *4 : When the battery is used for less than 100 hours per year, check the fluid level annually.
- The items listed above (@ marked) are registered as emission related critical parts by KUBOTA in the U.S.EPA nonroad emission regulation. As the engine owner, you are responsible for the performance of the required maintenance on the engine according to the above instruction.
Please see the Warranty Statement in detail.

W1035769

7. CHECK AND MAINTENANCE



CAUTION

- **Be sure to check and service the tractor on a level surface with the engine shut off and the parking brake “ON” and implement lowered to the ground.**

[1] DAILY CHECK

To prevent trouble from occurring, it is important to know the condition of the tractor. Check the following items before starting.

■ Walk Around Inspection

Look around the under the tractor for such items as loose bolts, trash build-up, oil or coolant leaks, broken or worn parts.

Checking

1. Checking and refueling.
2. Check the engine oil level.
3. Check the transmission fluid level.
4. Check the coolant level.
5. Clean panel and radiator screen.
6. Check the brake pedal.
7. Check the gauge, the meters and easy checkers.
8. Check the head light, the hazard light etc..
9. Check and clean the electrical wiring and the battery cables.
10. Check the seat belt and ROPS.

[2] CHECK POINTS OF INITIAL 50 HOURS

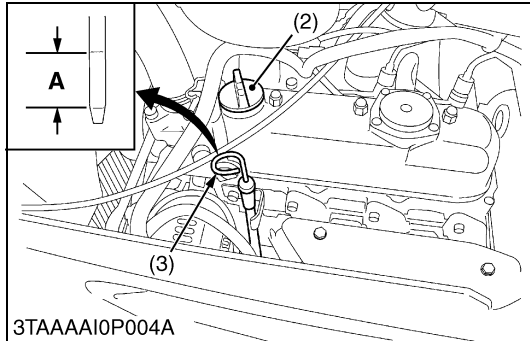
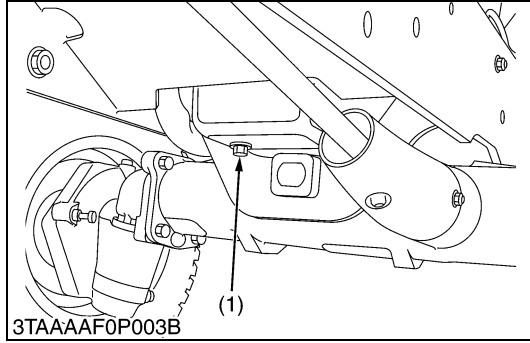

Changing Engine Oil

⚠ CAUTION

To avoid personal injury :

- Be sure to stop the engine and remove the key before changing the oil.
- Allow engine to cool down sufficiently, oil can be hot and can burn.

1. To drain the used oil, remove the drain plug at the bottom of the engine and drain the oil completely into the oil pan.
All the used oil can be drained out easily when the engine is still warm.
2. After draining reinstall the drain plug.
3. Fill with the new oil up to the upper notch on the dipstick.
4. Properly dispose of used oil.

Engine oil	Capacity	BX1860	2.9 L 3.1 U.S.qts 2.6 Imp.qts
		BX2360	3.1 L 3.3 U.S.qts 2.7 Imp.qts
		BX2660	3.5 L 3.7 U.S.qts 2.9 Imp.qts

- (1) Drain Plug
(2) Oil Inlet
(3) Dipstick

(A) Oil level is acceptable within this range.

W1014065

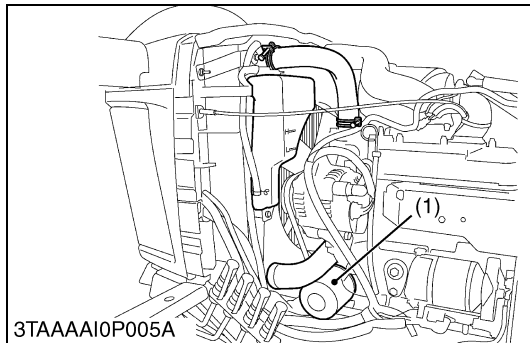

Replacing Engine Oil Filter

⚠ CAUTION

- Be sure to stop the engine before changing oil filter cartridge.

1. Remove the oil filter.
2. Put a film of clean engine oil on the rubber seal of the new filter.
3. Tighten the filter quickly until it contacts the mounting surface.
Tighten filter by hand an additional 1/2 turn only.
4. After the new filter has been replaced, the engine oil normally decrease a little. Make sure that the engine oil does not leak through the seal and be sure to check the oil level on the dipstick. Then, replenish the engine oil up to the specified level.
5. Properly dispose of used oil.

■ IMPORTANT

- To prevent serious damage to the engine, use only a KUBOTA genuine filter.

- (1) Engine Oil Filter Cartridge

W1014316

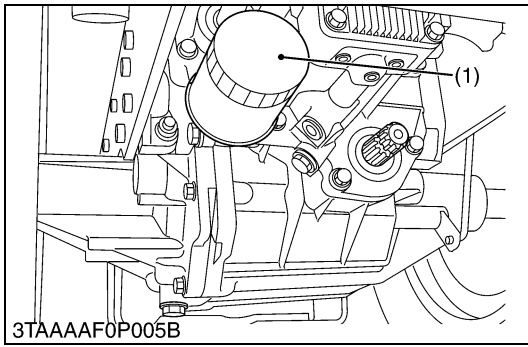

Replacing Transmission Oil Filter

CAUTION

- Allow engine to cool down sufficiently, oil can be hot and can burn.

1. Remove the oil filter.
2. Put a film of clean transmission oil on the rubber seal of the new filter.
3. Tighten the filter quickly until it contacts the mounting surface. Tighten filter by hand an additional 1/2 turn only.
4. After the new filter has been replaced, the transmission fluid level will decrease a little. Make sure that the transmission fluid does not leak through the seal, and check the fluid level. Top off if necessary.
5. Properly dispose of used oil.

IMPORTANT

- To prevent serious damage to the hydraulic system, use only a KUBOTA genuine filter.

(1) Transmission Oil Filter

W1014458

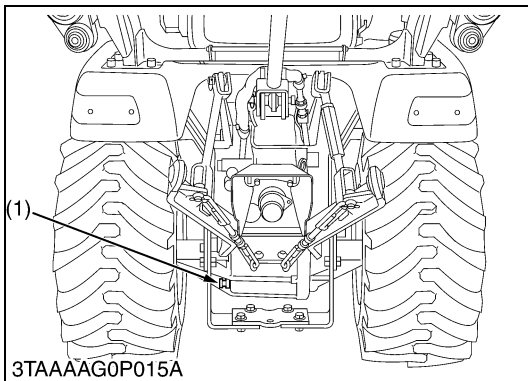

Cleaning Transmission Oil Strainer

1. When changing the transmission fluid, disassemble and rinse the strainer with nonflammable solvent to completely clean off fillings.
2. When reassembling, be careful not to damage the parts.

NOTE

- Since the fine fillings in the oil can damage the precision component parts of the hydraulic system, the end of the suction line is provided with an oil strainer.

(1) Strainer

(2) Filter Plate

W1019390

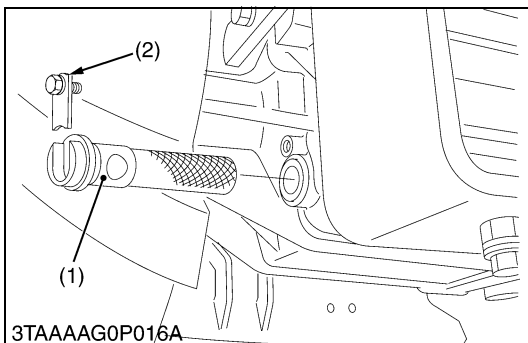

[3] CHECK POINTS OF EVERY 50 HOURS

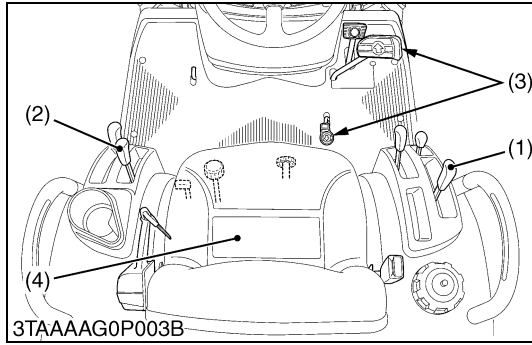

Checking Engine Start System

CAUTION

- Do not allow anyone near the tractor while testing.
- If the tractor does not pass the test do not operate the tractor.

■ Preparation before testing.

1. Sit on the operator's seat.
2. Set the parking brake and stop the engine.
3. Shift the range gear shift lever (1) to "NEUTRAL" position.
4. Check the speed control pedal "NEUTRAL" position
5. Shift the PTO clutch control lever (2) to "OFF" position.

■ Test 1 : Switch for the speed control pedal

1. Shift the range gear shift lever (1) to "NEUTRAL" position.
2. Depress the speed control pedal (3).
3. Turn the key to "START" position.
4. The engine must not crank.

■ Test 2 : Switch for the PTO clutch lever

1. Shift the range gear shift lever (1) to "NEUTRAL" position.
2. Check the speed control pedal (3) "NEUTRAL" position.
3. Shift the PTO clutch control lever (2) to "ON" position.
4. Turn the key to "START" position.
5. The engine must not crank.

■ Test 3 : Switches for the operator's seat and the speed control pedal

1. Sit on the operator's seat (4).
2. Shift the range gear shift lever (1) to "NEUTRAL" position.
3. Start the engine.
4. Depress the speed control pedal (3).
5. Stand up. (Do not get off the machine.)
6. The engine must shut off after approximately 1 second.

■ Test 4 : Switches for the operator's seat and the PTO clutch lever

1. Sit on the operator's seat.
2. Start the engine.
3. Engage the PTO clutch control lever (2).
4. Stand up. (Do not get off the machine.)
5. The engine must shut off after approximately 1 second.

- (1) Range Gear Shift Lever
(2) PTO Clutch Control Lever

- (3) Speed Control Level
(4) Operator's Seat

W1014904

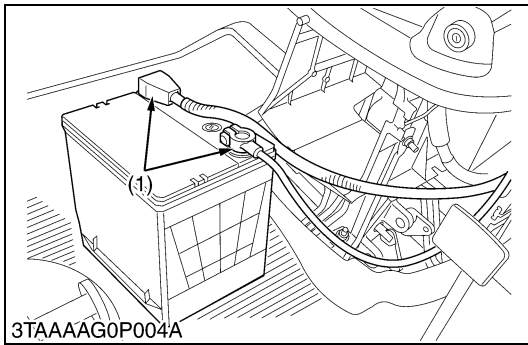

Greasing

1. Apply a small amount of multipurpose grease to the following points.

- (1) Battery Terminal
- (2) Speed Control Pedal

W1015242

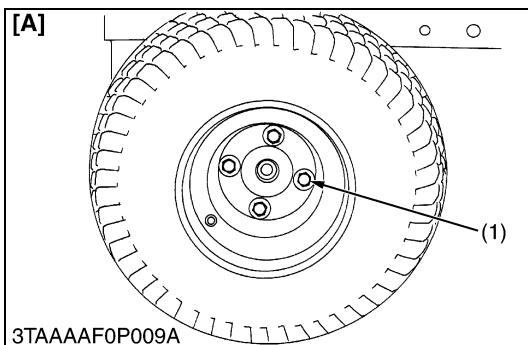
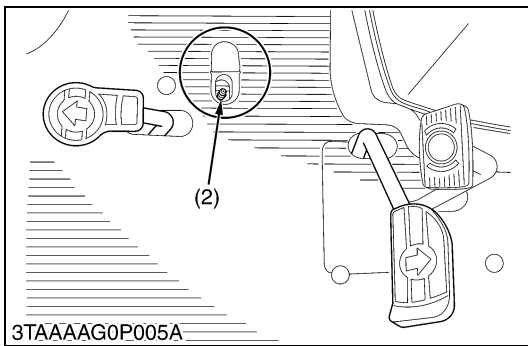

Checking Wheel Mounting Screws Tightening Torque

⚠ CAUTION

- Never operate tractor with a loose rim, wheel, or axle.
- Any time screws are loosened, retighten to specified torque.
- Check all screws frequently and keep them tight.

1. Check wheel screws regularly especially when new. If there are loosened, tighten as follows.

Tightening torque	Front wheel mounting screws	149.2 to 179.0 N·m 15.2 to 18.3 kgf·m 110 to 132 lbf·ft
	Rear wheel mounting screws	108.5 to 130.2 N·m 11.1 to 13.3 kgf·m 80 to 96 lbf·ft

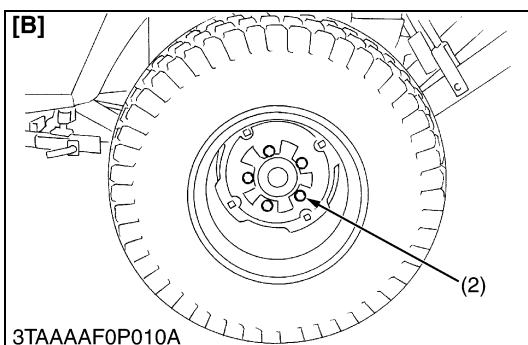

- (1) Front Wheel Mounting Screw
- (2) Rear Wheel Mounting Screw
- [A] Front
- [B] Rear

W1015311

[4] CHECK POINTS OF EVERY 100 HOURS

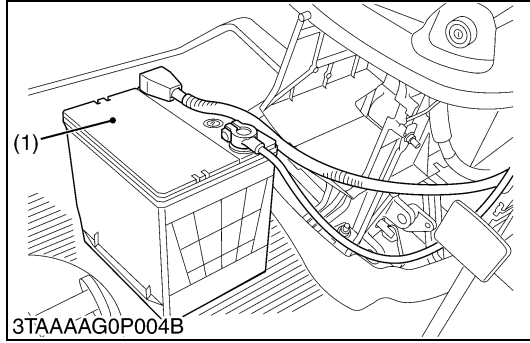

Checking Battery Condition

⚠ DANGER

To avoid the possibility of battery explosion:

For the refillable type battery, follow the instructions below.

- Do not use or charge the refillable type battery if the fluid level is below the LOWER (lower limit level) mark. Otherwise, the battery component parts may prematurely deteriorate, which may shorten the battery's service life or cause an explosion. Check the fluid level regularly and add distilled water as required so that the fluid level is between the UPPER and LOWER levels.

⚠ CAUTION

- Never remove the vent plugs while the engine is running.
 - Keep electrolyte away from eyes, hands and clothes. If you are spattered with it, wash it away completely with water immediately and get medical attention.
 - Wear eye protection and rubber gloves when working around battery.
1. Mishandling the battery shortens the service life and adds to maintenance costs.
 2. The original battery is maintenance free type battery, but need some servicing.
If the battery is weak, the engine is difficult to start and the lights become dim. It is important to check the battery periodically.

(1) Battery

W1015551

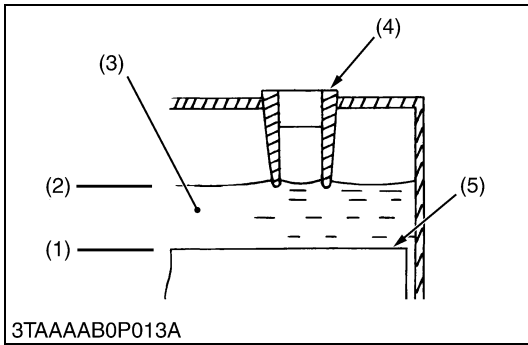

Checking Battery Condition (Continued)

■ Battery Charging

⚠ CAUTION

- When the battery is being activated, hydrogen and oxygen gases in the battery are extremely explosive. Keep open sparks and flames away from the battery at all times, especially when charging the battery.
- When charging battery, remove battery vent caps are securely in place (if equipped).
- When disconnecting the cable from the battery, start with the negative terminal first.

When connecting the cable to the battery, start with the positive terminal first.

- Never check battery charge by placing a metal object across the posts.

Use a voltmeter or hydrometer. (For accessible maintainable type batteries with removable vent caps.)

1. Make sure each electrolyte level is to the bottom of vent wells, if necessary add distilled water in a well-ventilated area.
2. The water in the electrolyte evaporates during recharging. Liquid shortage damages the battery. Excessive liquid spills over and damages the tractor body.
3. To slow charge the battery, connect the battery positive terminal to the charger positive terminal and the negative to the negative, then recharge in the normal manner.
4. A boost charge is only for emergencies. It will partially charges the battery at a high rate and in a short time.
When using a boost-charged battery, it is necessary to recharge the battery as early as possible.
Failure to do this will shorten the battery's service life.
5. When the specific gravity of electrolyte become between 1.27 and 1.29 charge has completed.
6. When exchanging an old battery for a new one, use battery of equal specification shown in table 1.

Table 1

Battery Type	Volts (V)	Reserve Capacity (min.)	Cold Cranking Amps
526RA	12	80	535

- (1) Lowest Level
- (2) Highest Level
- (3) Electrolyte
- (4) Vent Well
- (5) Separator

W1019057

Checking Battery Condition (Continued)

■ **Battery for storage**

1. When storing the tractor for a long period, remove the battery from tractor, adjust the electrolyte to the proper level and store in a dry place out of direct sunlight.
2. The battery self-discharges while it is stored.
Recharge it once every three months in hot seasons and once every six months in cold seasons.
3. (For non-accessible maintenance-free type batteries.)
Maintenance-free, non-accessible batteries are designed to eliminate the need to add water. Yet the volume of electrolyte above plates may eventually become depleted due to abnormal conditions such as high heat or improper regulator setting. Use a voltmeter to check the state of charge. (See reference chart below to determine if charging is necessary.)

Battery voltage	Reference state of charge
12.6	100 % (Full charge)
12.4	75 %
12.2	50 %
12.0	25 %
11.8	0 %

W1033625

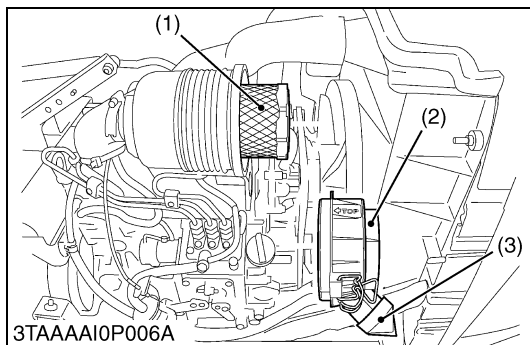

Cleaning Air Cleaner Element

CAUTION

- **Be sure to stop the engine and remove the key before cleaning air cleaner element.**
1. Remove the air cleaner cover (2) and the element (1).
 - Undo the hook.
 - Turn the cover clockwise and detach it.
 2. Clean the element:
 - When dry dust adheres to the element, blow compressed air from the inside, turning the element. Pressure of compressed air must be under 205 kPa (2.1 kgf/cm², 30 psi).
 - When carbon or oil adheres to the element, soak the element in detergent for 15 minutes then wash it several times in water, rinse with clean water and dry it naturally. After element is fully dried, inspect inside of the element with a light and check if it is damaged or not. (referring to the instructions on the label attached to the case.)
 3. Replace air cleaner element:
Once yearly or after every sixth cleaning, whichever comes first.

■ **NOTE**

- **Check to see if the evacuator valve is blocked with dust.**

■ **IMPORTANT**

- **The air cleaner uses a dry element, never apply oil.**
- **Do not run the engine with filter element removed.**
- **Align the arrow marks when reinstalling the cover. If the cover is improperly fitted, dust passes by the baffle and directly adheres to the element.**

■ **Evacuator Valve**

Open the evacuator valve once a week under ordinary conditions or daily when used in a dusty place to get rid of large particles of dust and dirt.

- (1) Element
- (2) Cover

- (3) Evacuator Valve

W1017166

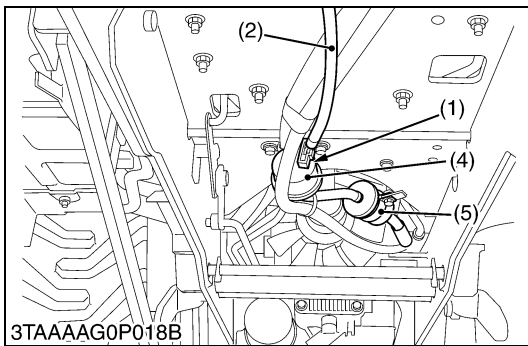
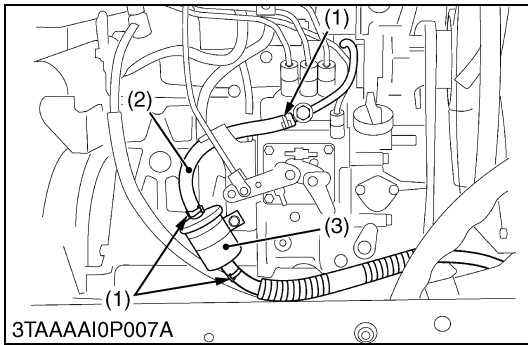

Checking Fuel Lines and Fuel Filter

⚠ CAUTION

- Stop the engine and remove the key before checking fuel lines and fuel filter.
- Check the fuel lines periodically. The fuel lines are subject to wear and aging. Fuel may leak out onto the running engine, causing a fire.

The fuel line connections should be checked annually or every 100 service hours, whichever occurs first.

1. The fuel line is made of rubber and ages regardless of service period.
2. After inspection, if the fuel line and clamps are found damaged or deteriorated, replace them.
3. Check fuel filter, if it is clogged by debris or contaminated by water, replace it.

■ IMPORTANT

- When the fuel line is disconnected for maintenance or repair, plug both ends of the fuel line with a clean plug of suitable size to prevent dust and dirt from entering. Particular care must be taken not to admit dust and dirt into the fuel system. Entrance of dust and dirt causes malfunction of the fuel pump.

■ NOTE

- If the fuel line is removed, be sure to properly bleed the fuel system (see “Bleeding Fuel System” in service as required).

- | | |
|-----------------|-----------------|
| (1) Pipe Clamps | (4) Fuel Pump |
| (2) Fuel Line | (5) Fuel Filter |
| (3) Fuel Filter | |

W1017546

Checking Fan Belt Tension

⚠ CAUTION

- Be sure to stop engine and remove the key before checking belt tension.

1. Stop the engine and remove the key.
2. Apply moderate thumb pressure to belt between pulleys.
3. If tension is incorrect, loosen the alternator mounting bolts and using a lever placed between the alternator and the engine block, pull the alternator out until the deflection of the belt falls within acceptable limits.
4. Replace fan belt if it is damaged.

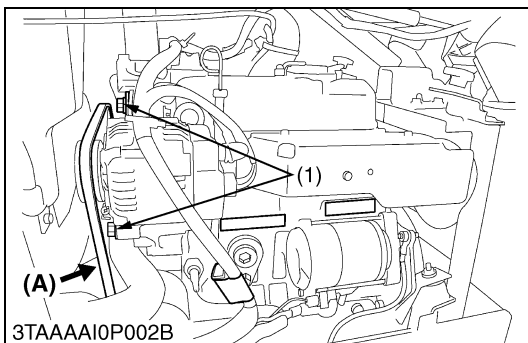

Fan belt tension	Factory spec.	A deflection of between 7 to 9 mm (0.28 to 0.34 in.) when the belt is pressed in the middle of the span.
------------------	---------------	--

(1) Mounting Bolt

(A) Check the belt tension

W1017708

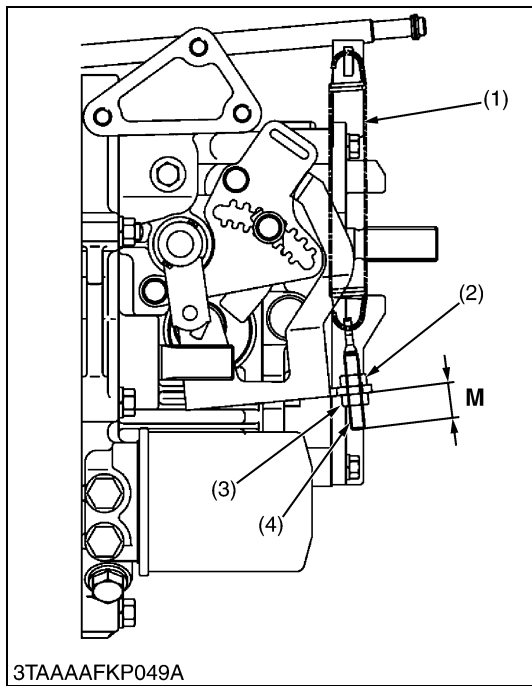
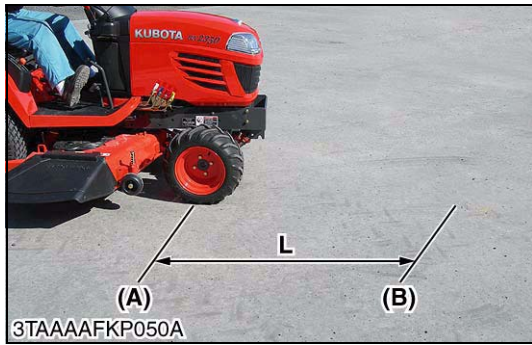

Adjusting HST Neutral Spring (for Dynamic Braking)

⚠ WARNING

- Do not operate if tractor move on level ground with foot off speed control pedal.
- If tractor moves on level ground with foot off the pedal, or, if the pedal is too slow in returning to “NEUTRAL” position when removing the foot from the pedal, adjust the HST neutral spring.

The HST neutral spring located under the front right side of the fender can adjust returning speed of speed control pedal.

Since the HST neutral spring tension is weakened, the HST tension should be checked and adjusted every 100 hours.

1. Checking the HST neutral spring tension : Dynamic braking
 - Start the engine and hold the maximum engine speeds.
 - Operate the machine on the concrete level ground.
 - Shift the range gear shift lever to “High” position.
 - Depress the speed control pedal to “Forward”.
 - Release the foot from the speed control pedal.
 - Check the distance between the foot releasing point and the machine stopping point.
 - If the distance is more than approximately 3 m (9.8 feet), strengthen the HST neutral spring tension so that the machine will stop in approximately 3 m (9.8 feet) after releasing the foot from the speed control pedal.

(Reference)

Distance (L) between the foot releasing point and the machine stopping point	Reference	Approximately 3 m (9.8 feet)
--	-----------	------------------------------

2. Remove the step from the machine.
 - Loosen the lock nut (2).
 - Turn the adjusting nut (3) half turn to pull the HST neutral spring (1).
 - Tighten and lock the lock nut (2).
 - Start the engine and check dynamic brake as mentioned former.
 - If the machine will not stop with dynamic brake in approximately 3 m (9.8 feet), adjust the neutral spring again.

(Reference)

Length (M) of adjusting rod at shipping the machine from the factory	Reference	10 mm 0.39 in.
--	-----------	-------------------

- (1) HST Neutral Spring
- (2) Lock Nut
- (3) Adjusting Nut
- (4) Adjusting Rod
- (A) Foot Releasing Point
- (B) Machine Stopping Point
- L : Distance between Foot Releasing Point and the Machine Stopping Point
- M : Length of Adjusting Rod from Stay

W1079634

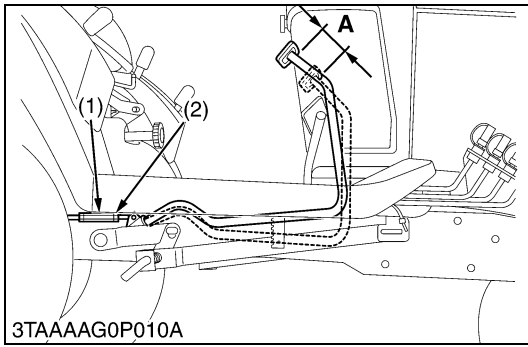

Adjusting Brake Pedal Free Travel

⚠ CAUTION

- Stop the engine, remove the key, lower the implement to the ground, and chock the wheels before checking brake pedal.
- Even if the brake pedal free travel is within the limitation, adjust the brake pedal following the procedure below.

1. Release the parking brake.
2. Loosen the lock nut and turn the turnbuckle to adjust the rod length so that the brake pedal free travel is 10 mm (0.4 in.).
3. Extend the turnbuckle one additional turn.
4. Retighten the lock nut.
5. Depress the brake pedal several times and make sure the brake pedal free travel is from 25 to 35 mm (1.0 to 1.4 in.).

Brake pedal free travel	Factory spec.	25 to 35 mm 1.0 to 1.4 in.
-------------------------	---------------	-------------------------------

- (1) Turnbuckle
(2) Lock Nut

A : Free Travel

W1018144

[5] CHECK POINTS OF EVERY 200 HOURS

Changing Engine Oil

1. See page G-13.

W1015501

Replacing Transmission Oil Filter

1. See page G-14.

W1019345

Replacing Engine Oil Filter

1. See page G-13.

W1018516

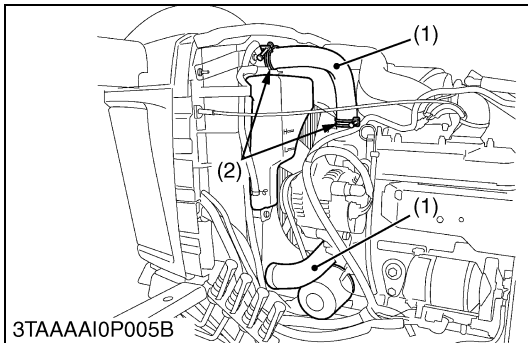

Checking Radiator Hoses and Hose Clamps

Check to see if radiator hoses are properly fixed every 200 hours of operation or six months, whichever comes first.

1. If hose clamps are loose or water leaks, tighten clamps securely.
2. Replace hoses and tighten hose clamps securely, if radiator hoses are swollen, hardened or cracked.
3. Properly dispose of used coolant.

Replace hoses and hose clamps every 2 years or earlier if checked and found that hoses are swollen, hardened or cracked.

■ Precaution at Overheating

Take the following actions in the event the coolant temperature be nearly or more than the boiling point, what is called “Overheating”.

1. Stop the machine operation in a safe place and keep the engine idling unloaded.
2. Don’t stop the engine suddenly, but stop it after about 5 minutes of unloaded idling.
3. Keep yourself well away from the machine for an additional 10 minutes or until the steam has blown out.
4. Checking that there is no danger such as burn, get rid of the cause of overheating according to the manual, see “ENGINE” section, and then, start the engine again.

- (1) Radiator Hose

- (2) Hose Clamp

W1018562

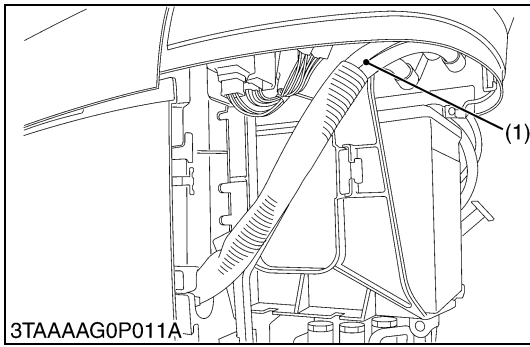

Checking Power Steering Line

CAUTION

• Be sure to stop the engine and remove the key before checking power steering line.

1. Check to see that all lines are tight and not damaged.
2. If hoses are found to be worn or damaged, replace or repair them at once.

(1) Power Steering Hose

W1018751

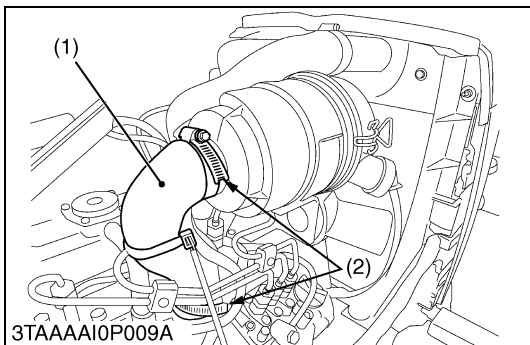
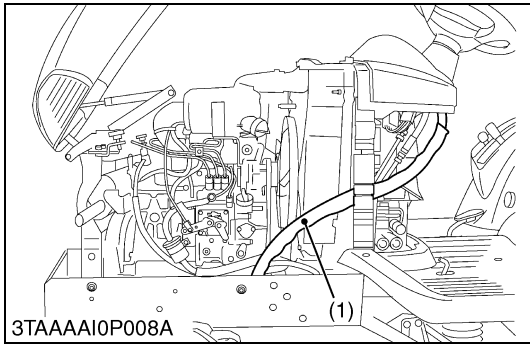

Checking Intake Air Line

1. Check to see that hose and hose clamps are tight and not damaged.
2. If hose and clamps are found to be worn or damaged, replace or repair them at once.

(1) Hose

(2) Clamp

W1018915

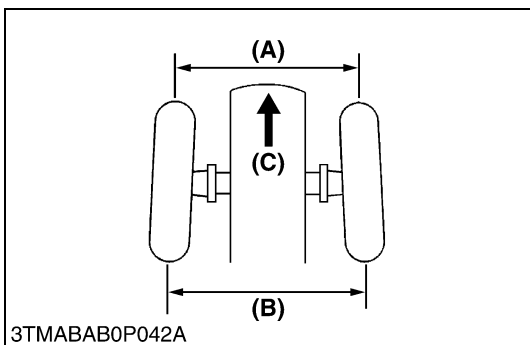

Adjusting Toe-in

1. Park tractor on a firm, flat and level place.
2. Turn steering wheel so front wheels are in the straight ahead position.
3. Lower the implement to the ground, lock the parking brake, stop the engine and remove the key.
4. Measure distance between tire beads at front of tire at hub height.
5. Measure distance between tire beads at rear of tire at hub height.
6. Front distance should be 0 to 5.0 mm (0 to 0.2 in.) less than rear distance. If not, adjust tie rod length.

Toe-in (B – A)	Factory spec.	0 to 5.0 mm 0 to 0.2 in.
----------------	---------------	-----------------------------

Adjusting

1. Loosen the lock nuts and turn the steering tie-rod to adjust the rod length until the proper toe-in measurement is obtained.
2. Retighten the lock nuts.

(1) Lock Nut

(2) Tie-rod

A : Wheel to Wheel Distance at Front

B : Wheel to Wheel Distance at Rear

C : Front

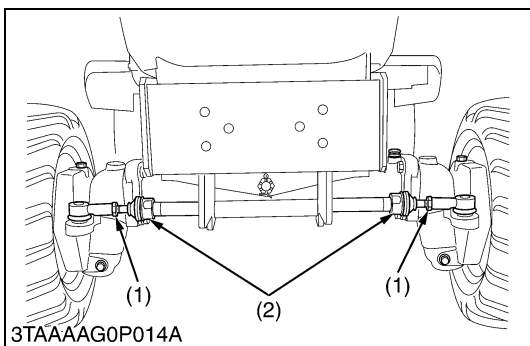

W1019009

[6] CHECK POINTS OF EVERY 400 HOURS

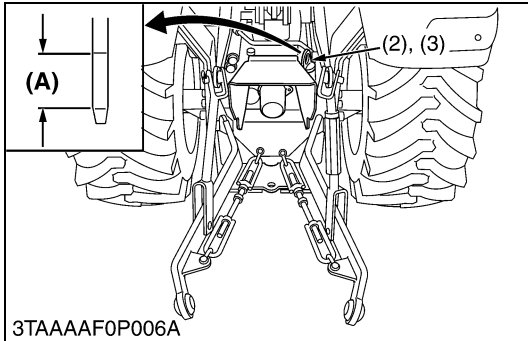
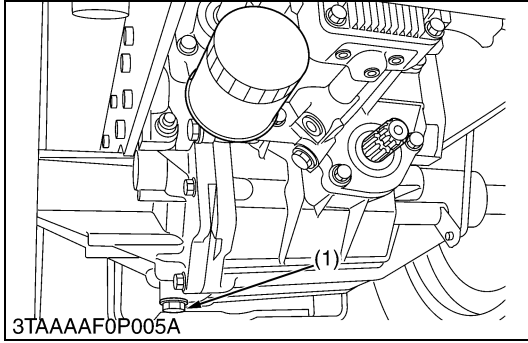

Changing Transmission Fluid

⚠ CAUTION

- Allow engine to cool down sufficiently, oil can be hot and can burn.

1. To drain the used oil, remove the drain plug at the bottom of the transmission case and drain the oil completely into the oil pan.
2. After draining reinstall the drain plug.
3. Clean the transmission strainer.
4. Fill with new KUBOTA SUPER UDT fluid up to the upper notch on the dipstick.
5. After running the engine for a few minutes, stop it and check the oil level again, add oil to prescribed level.
6. Properly dispose of used oil.

■ IMPORTANT

- Use only multi-grade transmission oil. Use of other oils may damage the transmission or hydraulic system. Refer to "LUBRICANTS, FUEL AND COOLANT". (See page G-7.)

Transmission fluid	Capacity	11.6 L 3.1 U.S.gals 2.6 Imp.gals
--------------------	----------	--

- (1) Drain Plug
- (2) Filling Plug
- (3) Dipstick

(A) Oil level is acceptable within this range.

W1014665

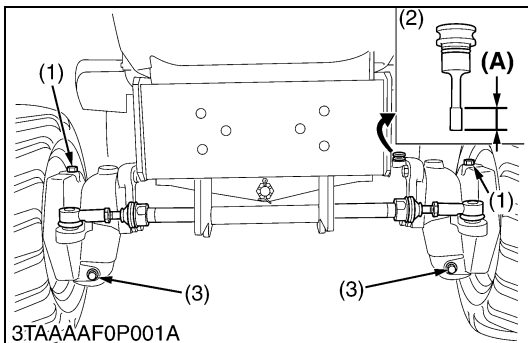

Changing Front Axle Case Oil

1. Park the machine on a firm, flat and level surface.
2. To drain the used oil, remove the right and left drain plugs and oil gauge at the front axle case and drain the oil completely into the oil pan.
3. After draining, reinstall the drain plugs.
4. Remove the right and left breather plugs.
5. Fill with new oil up to the upper notch on the dipstick.

■ IMPORTANT

- After ten minutes, check the oil level again; add oil to prescribed level.
6. After filling, reinstall the oil gauge and breather plugs.

Front axle case oil	Capacity	BX1860	2.3 L 2.4 U.S.qts 2.0 Imp.qts
		BX2360 BX2660	4.7 L 5.0 U.S.qts 4.1 Imp.qts

- (1) Breather Plug
- (2) Oil Gauge with Dipstick
- (3) Drain Plug

(A) Oil level is acceptable within this range.

W1019508

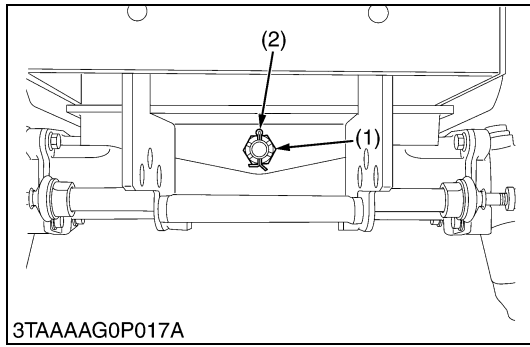

Adjusting Front Axle Pivot

1. Remove the split pin (2), tighten the adjusting nut (1).
2. Make sure that one of the nut slots aligns with the split pin hole, tighten the nut slightly if necessary to align.
3. Replace the split pin.

Tightening torque	Factory spec.	20 N·m 2.0 kgf·m 14 lbf·ft
-------------------	---------------	----------------------------------

(1) Adjusting Nut

(2) Split Pin

W1019713

[7] CHECK POINT OF EVERY 500 HOURS

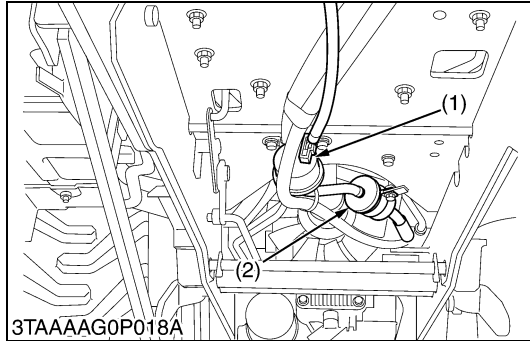

Replacing Fuel Filter Element

1. Disconnect the fuel hoses and replace the fuel filter (2).
2. Disconnect the fuel hoses and loosen the pipe clamp to replace the fuel filter (5).

NOTE

- If the fuel line is removed, be sure to properly bleed the fuel system. (See page G-30.)

(1) Fuel Pump

(4) Hose Clamp

(2) Fuel Filter

(5) Fuel Filter

(3) Fuel Line

W1019858

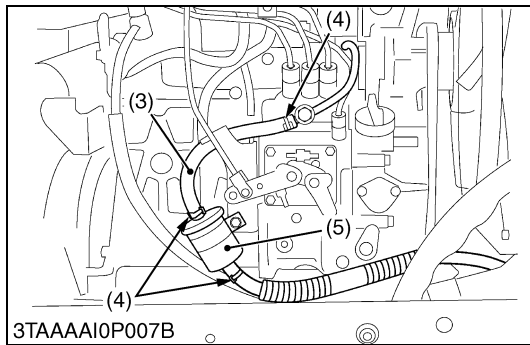

[8] CHECK POINT OF EVERY 800 HOURS

Adjusting Engine Valve Clearance

1. See page 1-S18.

W1019995

[9] CHECK POINT OF EVERY 1500 HOURS

Checking Fuel Injection Nozzle Injection Pressure

1. See page 1-S24.

W1020203

[10] CHECK POINT OF EVERY 3000 HOURS

Checking Injection Pump

1. See page 1-S23.

W1020260

[11] CHECK POINT OF EVERY 1 YEAR

Replacing Air Cleaner Element

1. See page G-19.

W1020343

[12] CHECK POINTS OF EVERY 2 YEARS

Replacing Radiator Hoses (Water Pipes)

1. Replace the hoses and clamps.
 Refer to “**Checking Radiator Hoses and Hose Clamps**”.
 (See page G-22.)

W1020468

Replacing Power Steering Hoses

1. Replace the hoses.
 Refer to “**Checking Power Steering Line**”.
 (See page G-23.)

W1020513

Replacing Fuel Line

1. Replace the hoses and clamps.
 Refer to “**Checking Fuel Line and Fuel Filter**”.
 (See page G-20.)

W1020558

Replacing Intake Air Line

1. Replace the intake hose.
2. Refer to “**Checking Intake Air Line**”.
 (See page G-23.)

W1020422

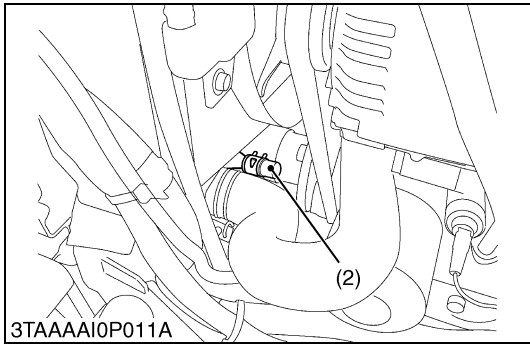
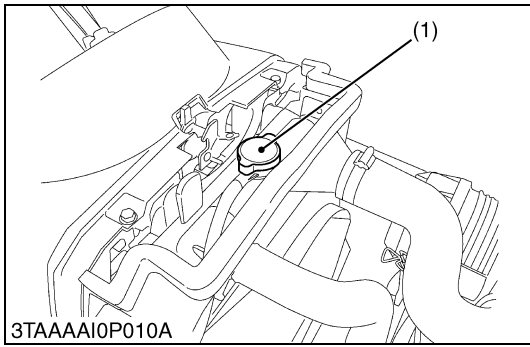

Flush Cooling System and Changing Coolant

⚠ CAUTION

- Be sure to stop the engine and remove the key before checking coolant level.
- Do not remove the radiator cap when the engine is hot. Then loosen cap slightly to the stop to relieve any excess pressure before removing cap completely.

1. Stop the engine, remove the key and let cool down.
2. To drain the coolant, open the radiator drain plug, and remove radiator cap. The radiator cap must be removed to completely drain the coolant.
3. After all coolant is drained, close the drain plug.
4. Fill with clean water and cooling system cleaner.
5. Follow directions of the cleaner instruction.
6. After flushing, fill with clean water and anti-freeze until the coolant level is just below the radiator cap. Install the radiator cap securely.
7. Fill with coolant up to “H” mark on the recovery tank.
8. Start and operate the engine for few minutes.
9. Stop the engine, remove the key and let cool.
10. Check coolant level of recovery tank and add coolant if necessary.
11. Properly dispose of used coolant.

■ IMPORTANT

- Do not start engine without coolant.
- Use clean, fresh water and anti-freeze to fill the radiator.
- When the anti-freeze is mixed with water, the anti-freeze mixing ratio must be less than 50 %.
- Securely tighten radiator cap. If the cap is loose or improperly fitted, water may leak out and the engine could overheat.

Coolant	Capacity (with recovery tank)	BX1860	2.9 L 3.1 U.S.qts 2.6 Imp.qts
		BX2360	3.1 L 3.3 U.S.qts 2.7 Imp.qts
		BX2660	3.3 L 3.5 U.S.qts 2.9 Imp.qts

(1) Radiator Cap

(2) Drain Plug

W1021307

Flush Cooling system and Changing Coolant (Continued)

■ **Anti-Freeze**



CAUTION

- **When using antifreeze, put on some protection such as rubber gloves (Antifreeze contains poison).**
- **If should drink antifreeze, throw up at once and take medical attention.**
- **When antifreeze comes in contact with the skin or clothing, wash it off immediately.**
- **Do not mix different types of Antifreeze.**
The mixture can produce chemical reaction causing harmful substances.
- **Antifreeze is extremely flammable and explosive under certain conditions. Keep fire and children away from antifreeze.**
- **When draining fluids from the engine, place some container underneath the engine body.**
- **Do not pour waste onto the grounds, down a drain, or into any water source.**
- **Also, observe the relevant environmental protection regulations when disposing of antifreeze.**

If it freezes, coolant can damage the cylinders and radiator. If the ambient temperature falls below 0 °C (32 °F) or before a long-term storage, let out coolant completely, or mix fresh water with long-life coolant and fill the radiator and reserve tank with the mixture.

1. Long-life coolant (hereafter LLC) comes in several types. Use ethylene glycol (EG) type for this engine.
2. Before employing LLC-mixed coolant, fill the radiator with fresh water and empty it again.

Repeat this procedure 2 or 3 times to clean up the inside.

3. Mixing the LLC.
Put the LLC in coolant in the percentage (%) for a target temperature. When mixing, stir it up well, and then fill into the radiator.
4. The procedure for the mixing of water and antifreeze differs according to the make of the antifreeze and the ambient temperature. Refer to SAE J1034 standard, more specifically also to SAE J814c.

■ **IMPORTANT**

- **When the antifreeze is mixed with water, the antifreeze mixing ratio must be less than 50 %.**

Vol % Anti-freeze	Freezing Point		Boiling Point*	
	°C	°F	°C	°F
40	-24	-12	106	222
50	-37	-34	108	226

* At 1.013 × 10⁵ Pa (760 mmHg) pressure (atmospheric).

A higher boiling point is obtained by using a radiator pressure cap which permits the development of pressure within the cooling system.

W1022492

Flush Cooling system and Changing Coolant (Continued)

5. Adding the LLC.
 - Add only water if the mixture reduces in amount by evaporation.
 - If there is a mixture leak, add the LLC of the same manufacture and type in the same mixture percentage.
 - * Never add any long-life coolant of different manufacture. (Different brands may have different additive components, and the engine may fail to perform as specified.)
6. When the LLC is mixed, do not employ any radiator cleaning agent. The LLC contains anticorrosive agent. If mixed with the cleaning agent, sludge may build up, adversely affecting the engine parts.
7. Kubota's genuine long-life coolant has a service life of 2 years. Be sure to change the coolant every 2 years.

W1032576

[13] OTHERS

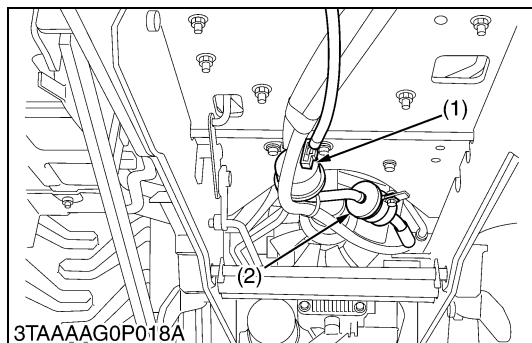

Bleeding Fuel System

Air must removed:

1. When the fuel filter (2) or lines are removed.
2. When tank is completely empty.
3. After the tractor has not been used for a long period of time.

■ Bleeding procedure is as follows:

1. Fill the fuel tank with fuel.
2. Turn the key switch to “ON” position for about 30 seconds. Doing so allows fuel pump (1) to work and pump air out of the fuel system.
3. Start the engine and run for about 30 seconds, and then stop the engine.

(1) Fuel Pump

(2) Fuel Filter

W1021149

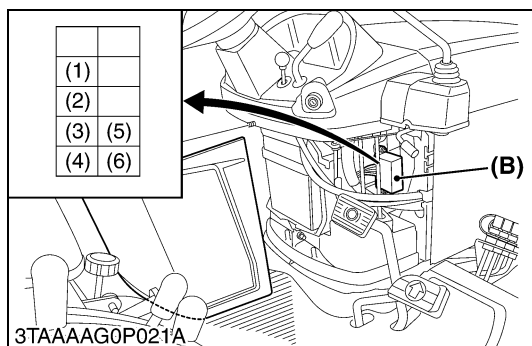

Replacing Fuse

1. The tractor electrical system is protected from potential damage by fuses. A blown fuse indicates that there is an overload or short somewhere in the electrical system.
2. If any of the fuses should blow, replace with a new one of the same capacity.

■ IMPORTANT

- Before replacing a blown fuse, determine why the fuse blew and make any necessary repairs. Failure to follow this procedure may result in serious damage to the tractor electrical system.
- If any of the fuses should blow, replace with a new one of the same capacity.

■ Protected Circuit

[Fuse Box]

Fuse No.	Capacity (A)	Protected circuit
(1)	15	Solenoid
(2)	15	Hazard
(3)	15	ACC
(4)	20	Working Light
(5)	10	DC Outlet
(6)	10	Timer Relay

Fuse No.	Capacity (A)	Protected circuit
(7)	Slow Blow Fuse (50A)	Check circuit against wrong battery connection

(B) Fuse Box

W1023430

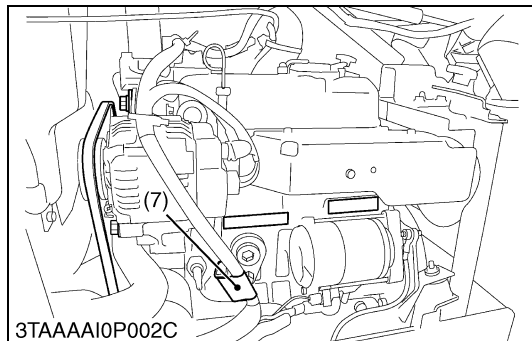

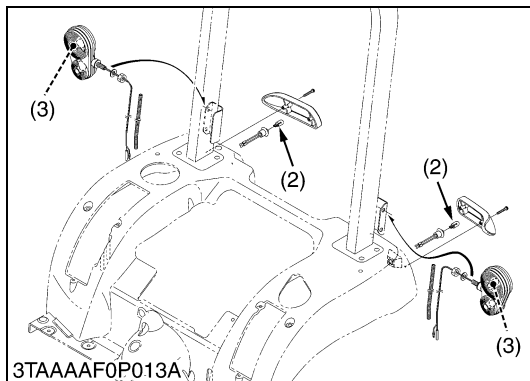
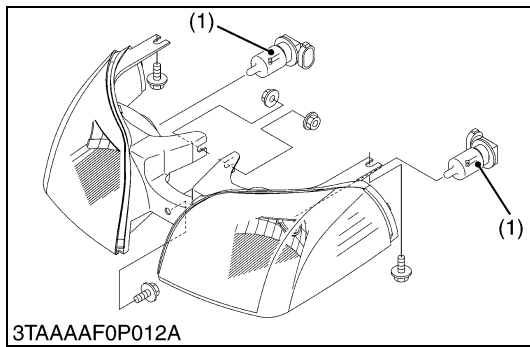

Replacing Light Bulb

1. Head lights:
Take the bulb out of the light body and replace with a new one.
2. Other lights:
Detach the lens and replace the bulb.

Light	Capacity
Head light	37.5 W
Tail light	12.8 W
Hazard light	23 W

- (1) Head Light
(2) Tail Light

- (3) Hazard Light

W1023802

8. SPECIAL TOOLS

[1] SPECIAL TOOLS FOR ENGINE

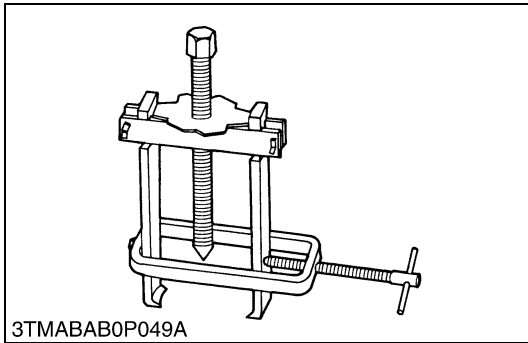

Special Use Puller Set

Code No.: 07916-09032

Application: Use exclusively for pulling out bearing, gears and other parts with ease.

W1024050

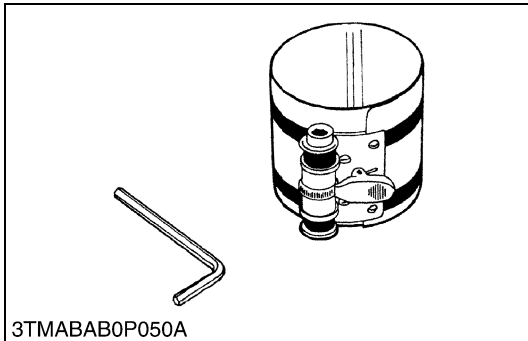

Piston Ring Compressor

Code No.: 07909-32111

Application: Use exclusively for pushing in the piston with piston rings into the cylinder.

W1024100

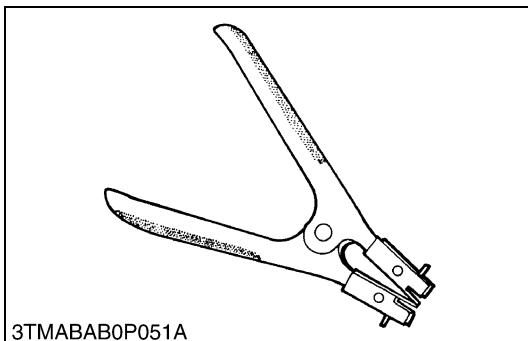

Piston Ring Tool

Code No.: 07909-32121

Application: Use exclusively for removing or installing the piston ring with ease.

W1024150

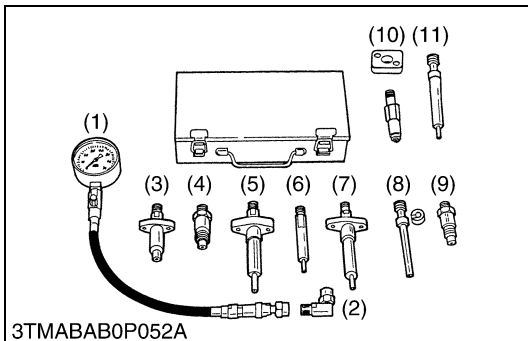

Diesel Engine Compression Tester (for Injection Nozzle)

Code No.: 07909-30208 (Assembly) 07909-31251 (G)
 07909-30934 (A to F) 07909-31271 (I)
 07909-31211 (E and F) 07909-31281 (J)
 07909-31231 (H)

Application: Use to measure diesel engine compression and diagnostics of need for major overhaul.

- | | |
|---------------|----------------|
| (1) Gauge | (7) Adaptor F |
| (2) L Joint | (8) Adaptor G |
| (3) Adaptor A | (9) Adaptor H |
| (4) Adaptor B | (10) Adaptor I |
| (5) Adaptor C | (11) Adaptor J |
| (6) Adaptor E | |

W1024200

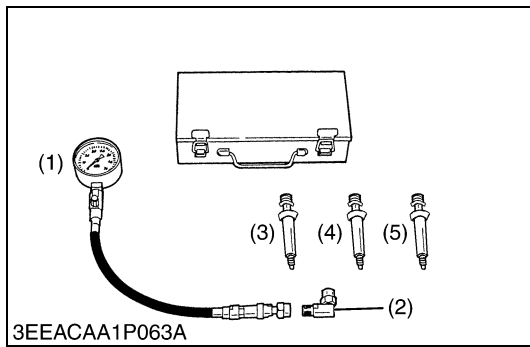

Diesel Engine Compression Tester (for Glow Plug)

Code No.: 07909-39081 (Assembly) 07909-31301 (L)
07909-31291 (K) 07909-31311 (M)

Application: Use to measure diesel engine compression and diagnostics of need for major overhaul.

- (1) Gauge
- (2) L Joint
- (3) Adaptor K
- (4) Adaptor L
- (5) Adaptor M

000001398E

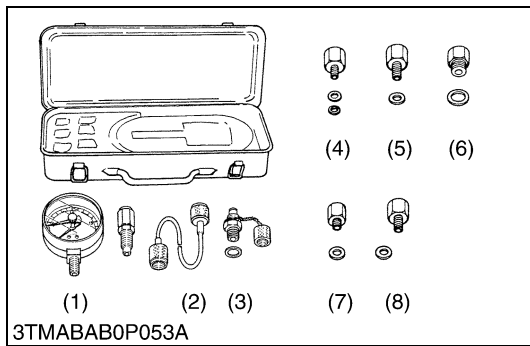

Oil Pressure Tester

Code No.: 07916-32032

Application: Use to measure lubricating oil pressure.

- (1) Gauge
- (2) Cable
- (3) Threaded Joint
- (4) Adaptor 1
- (5) Adaptor 2
- (6) Adaptor 3
- (7) Adaptor 4
- (8) Adaptor 5

W1024318

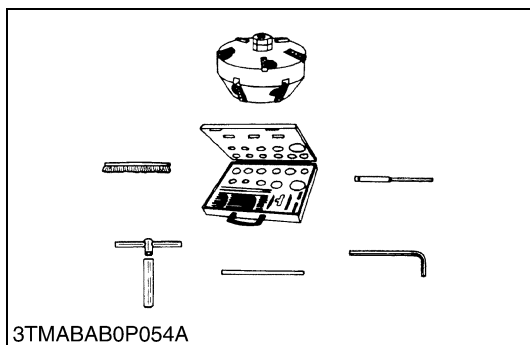

Valve Seat Cutter

Code No.: 07909-33102

Application: Use to reseal valves.

Angle: 0.785 rad (45°)
0.262 rad (15°)

Diameter: 28.6 mm (1.126 in.) 38.0 mm (1.496 in.)
31.6 mm (1.244 in.) 41.3 mm (1.626 in.)
35.0 mm (1.378 in.) 50.8 mm (2.000 in.)

W1024458

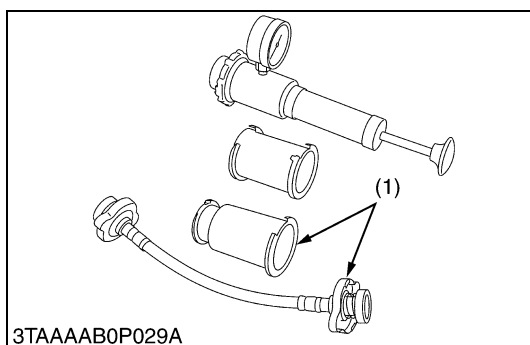

Radiator Tester

Code No.: 07909-31551

Application: Use to check of radiator cap pressure, and leaks from cooling system.

Remarks: Adaptor (1) BANZAI Code No. RCT-2A-30S

W1024532

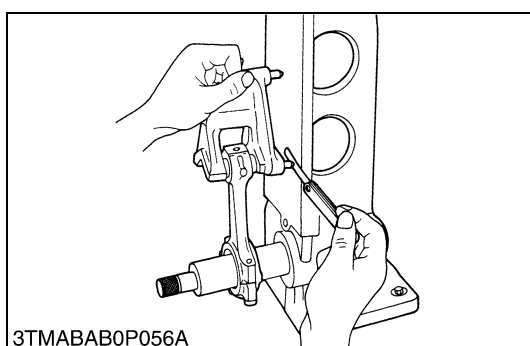

Connecting Rod Alignment Tool

Code No.: 07909-31661

Application: Use to check the connecting rod alignment.

Applicable: Connecting rod big end I.D.
range 30 to 75 mm (1.18 to 2.95 in.) dia.
Connecting rod length
65 to 300 mm (2.56 to 11.81 in.)

W1024583

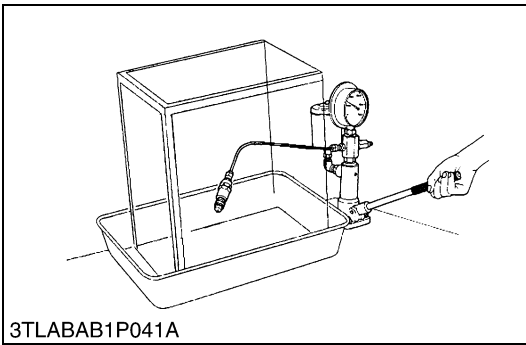

3TLABAB1P041A

Nozzle Tester

Code No.: 07909-31361

Application: Use to check the fuel injection pressure and spray pattern of nozzle.

Measuring: 0 to 50 MPa
range (0 to 500 kgf/cm², 0 to 7000 psi)

W1024653

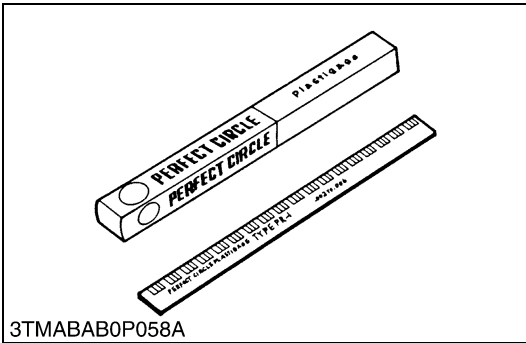

3TMABAB0P058A

Plastigage

Code No.: 07909-30241

Application: Use to check the oil clearance between crankshaft and bearing, etc..

Measuring: Green 0.025 to 0.076 mm (0.001 to 0.003 in.)
range Red 0.051 to 0.152 mm (0.002 to 0.006 in.)
Blue 0.102 to 0.229 mm (0.004 to 0.009 in.)

W1024719

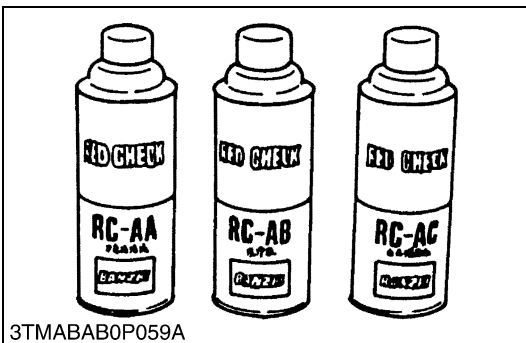

3TMABAB0P059A

Red Check

Code No.: 07909-31371

Application: Use to check cracks on cylinder head, cylinder block, etc..

W1024909

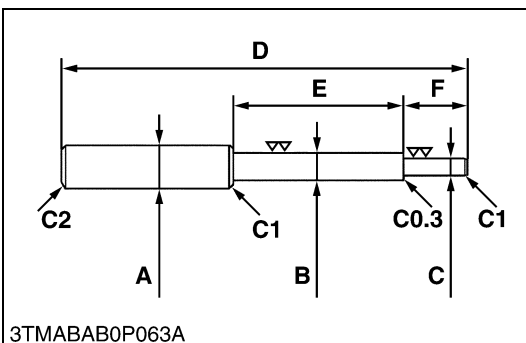

3TMABAB0P063A

Valve Guide Replacing Tool

Application: Use to press out and press fit the valve guide.

A	20 mm dia. (0.79 in. dia.)
B	11.7 to 11.9 mm dia. (0.460 to 0.468 in. dia.)
C	6.5 to 6.6 mm dia. (0.256 to 0.259 in. dia.)
D	225 mm (8.86 in.)
E	70 mm (2.76 in.)
F	45 mm (1.77 in.)
G	25 mm (0.98 in.)
H	5 mm (0.197 in.)
I	6.7 to 7.0 mm dia. (0.263 to 0.275 in. dia.)
J	20 mm dia. (0.787 in. dia.)
K	12.5 to 12.8 mm dia. (0.492 to 0.504 in. dia.)
L	8.9 to 9.1 mm (0.350 to 358 in.)
C1	Chamfer 1.0 mm (0.039 in.)
C2	Chamfer 2.0 mm (0.079 in.)
C0.3	Chamfer 0.3 mm (0.012 in.)

W1025017

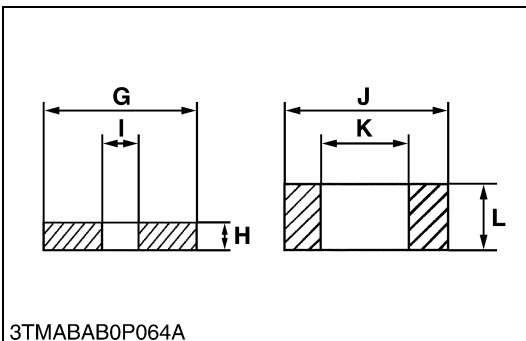

3TMABAB0P064A

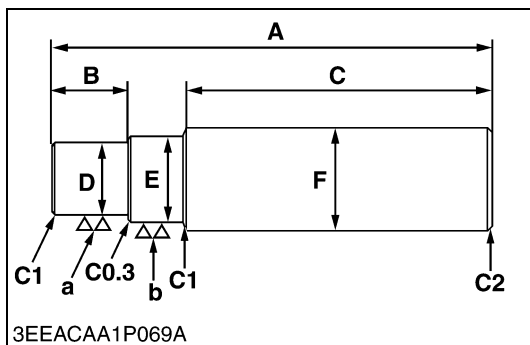
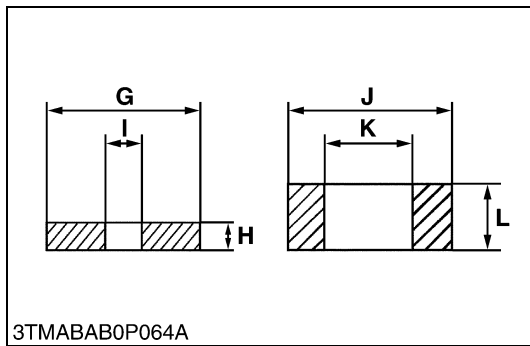
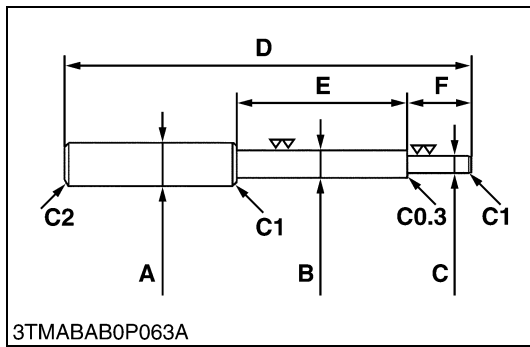

Valve Guide Replacing Tool

Application: Use to press out and press fit the valve guide.

A	20 mm dia. (0.79 in. dia.)
B	9.96 to 9.98 mm dia. (0.3921 to 0.3929 in. dia.)
C	5.5 to 5.7 mm dia. (0.2165 to 0.2244 in. dia.)
D	220 mm (8.66 in.)
E	80 mm (3.15 in.)
F	40 mm (1.58 in.)
G	25 mm dia. (0.98 in. dia.)
H	5 mm (0.197 in.)
I	6.0 to 6.1 mm dia. (0.236 to 0.240 in. dia.)
J	18 mm dia. (0.71 in. dia.)
K	10.6 to 10.7 mm dia. (0.417 to 0.421 in. dia.)
L	6.9 to 7.1 mm (0.272 to 0.280 in.)
C1	Chamfer 1.0 mm (0.039 in.)
C2	Chamfer 2.0 mm (0.079 in.)
C0.3	Chamfer 0.3 mm (0.012 in.)

W12345689

Bushing Replacing Tool

Application: Use to press out and press fit the bushing.

1. For small end bushing

A	145 mm (5.71 in.)
B	20 mm (0.79 in.)
C	100 mm (3.94 in.)
D	19.90 to 19.95 mm dia. (0.7835 to 0.7854 in. dia.)
E	21.90 to 21.95 mm dia. (0.8622 to 0.8642 in. dia.)
F	25 mm dia. (0.98 in. dia.)
C1	Chamfer 1.0 mm (0.039 in.)
C2	Chamfer 2.0 mm (0.079 in.)
C0.3	Chamfer 0.3 mm (0.012 in.)
a	6.3 μm (250 μin.)
b	6.3 μm (250 μin.)

2. For idle gear bushing

A	150 mm (5.91 in.)
B	23 mm (0.91 in.)
C	100 mm (3.94 in.)
D	19.90 to 19.95 mm dia. (0.7835 to 0.7854 in. dia.)
E	21.90 to 21.95 mm dia. (0.8622 to 0.8642 in. dia.)
F	25 mm dia. (0.98 in. dia.)
C1	Chamfer 1.0 mm (0.039 in.)
C2	Chamfer 2.0 mm (0.079 in.)
C0.3	Chamfer 0.3 mm (0.012 in.)
a	6.3 μm (250 μin.)
b	6.3 μm (250 μin.)

W12358870

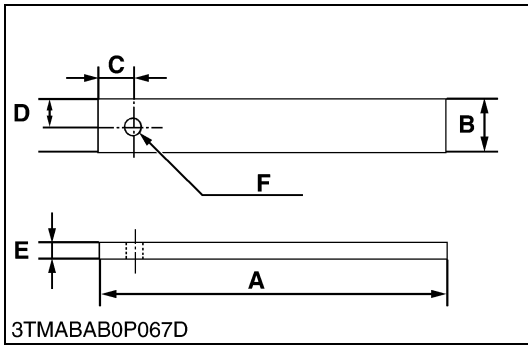

Flywheel Stopper

Application: Use to loosen and tighten the flywheel screw.

A	200 mm (7.87 in.)
B	30 mm (1.18 in.)
C	20 mm (0.79 in.)
D	15 mm (0.59 in.)
E	8 mm (0.31 in.)
F	10 mm dia. (0.39 in. dia.)

W98765423

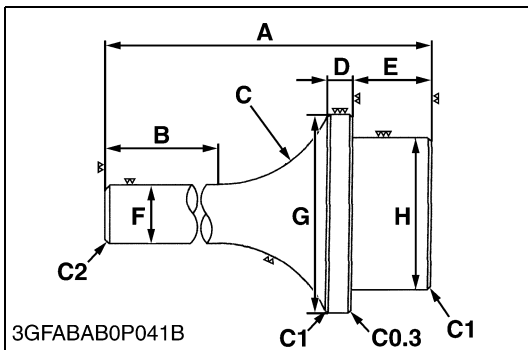

Crankshaft Bearing 1 Replacing Tool

Application: Use to press out and press fit the crankshaft bearing 1.

[Press Out]

A	135 mm (5.31 in.)
B	72 mm (2.83 in.)
C	40 mm radius (1.57 in. radius)
D	10 mm (0.39 in.)
E	22 mm (0.87 in.)
F	20 mm dia. (0.79 in. dia.)
G	56.80 to 56.90 mm dia. (2.2362 to 2.2402 in. dia.)
H	51.80 to 51.90 mm dia. (2.0393 to 2.0433 in. dia.)
C1	Chamfer 1.0 mm (0.039 in.)
C2	Chamfer 2.0 mm (0.079 in.)
C0.3	Chamfer 0.3 mm (0.012 in.)

[Press Fit]

A	130 mm (5.12 in.)
B	72 mm (2.83 in.)
C	40 mm radius (1.57 in. radius)
D	9 mm (0.35 in.)
E	24 mm (0.95 in.)
F	20 mm dia. (0.79 in. dia.)
G	68 mm dia. (2.68 in. dia.)
H	47.38 to 47.48 mm dia. (1.865 to 1.869 in. dia.)
C1	Chamfer 1.0 mm (0.039 in.)
C2	Chamfer 2.0 mm (0.079 in.)
C0.3	Chamfer 0.3 mm (0.012 in.)

W56478912

[2] SPECIAL TOOLS FOR TRACTOR

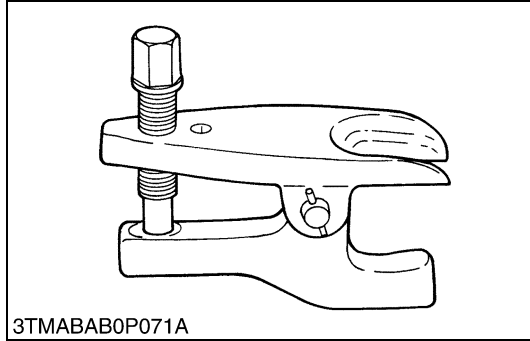

3TMABAB0P071A

Tie-rod End Lifter

Code No.: 07909-39051

Application: Use for removing the tie-rod end with ease

W1026472

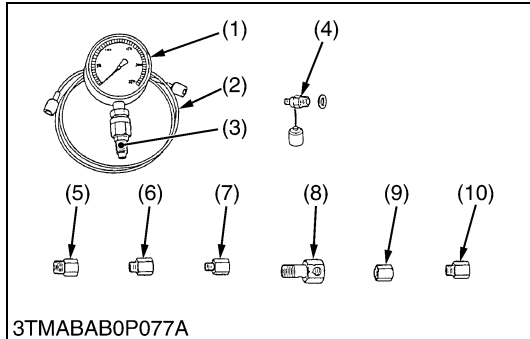

3TMABAB0P077A

Relief Valve Pressure Tester

Code No.: 07916-50045

Application: This allows easy measurement of relief set pressure.

- | | |
|---|--|
| (1) Gauge (07916-50322) | (6) Adaptor C (PS3/8) (07916-50371) |
| (2) Cable (07916-50331) | (7) Adaptor D (PT1/8) (07916-50381) |
| (3) Threaded Joint (07916-50401) | (8) Adaptor E (PS3/8) (07916-50392) |
| (4) Threaded Joint (07916-50341) | (9) Adaptor F (PF1/2) (07916-62601) |
| (5) Adaptor B (M18 × P1.5) (07916-50361) | (10) Adaptor 58 (PT1/4) (07916-52391) |

W1026741

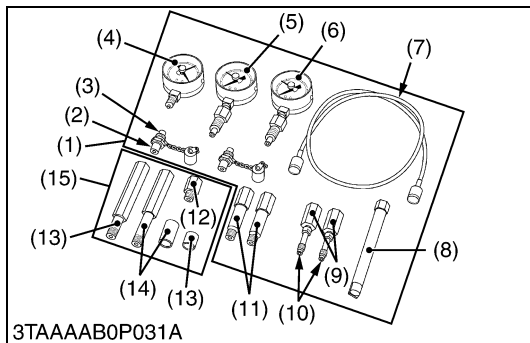

3TAAAB0P031A

Hydrostatic Transmission Tester and HST Adaptor Set

Code No.: 07916-52040 (Hydrostatic Transmission Tester)

07916-53072 (HST Adaptor Set)

Application: This allows easy measurement of hydrostatic transmission pressure.

- | | |
|--|---|
| (1) Hydrostatic Transmission Tester (07916-52040) | (8) Valve Seat Driver (07916-60841) |
| (2) Gasket (04714-00200) | (9) Connector 1 (07916-60811) |
| (3) Connector 3 (07916-51331) | (10) Connector 2 (07916-60821) |
| (4) Vacuum Gauge (07916-51331) | (11) Long Connector (07916-60831) |
| (5) Pressure Gauge (Low Pressure) (07916-51301) | (12) Adaptor 1 (07916-52621) |
| (6) Pressure Gauge (High Pressure) (in Relief Valve Set Pressure Tester) (07916-50321) | (13) Adaptor 2 with Collar (07916-52632) |
| (7) HN Tube (in Relief Valve Set Pressure Tester) (07916-50331) | (14) Adaptor 3 with Collar (07916-52642) |
| | (15) HST Adaptor Set (07916-53072) |

W1023682

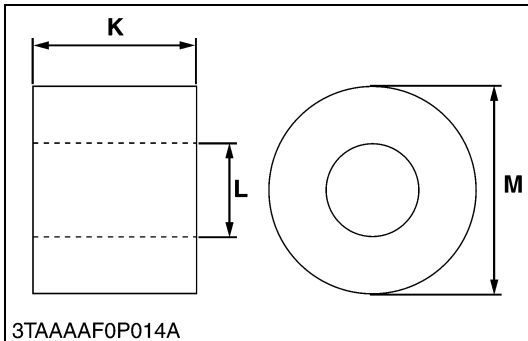
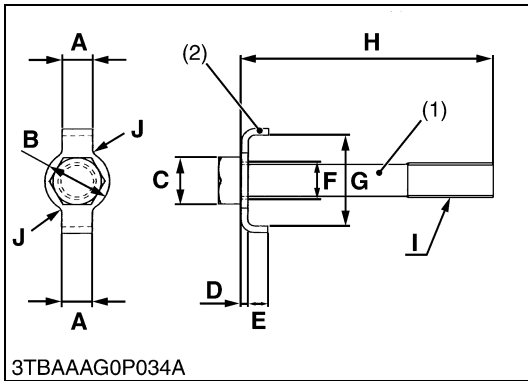

Independent PTO Clutch Spring Compression Tool

Application: Use for compressing the spring into the spline boss.

This tool can be used for B30 series, BX50 series, BX60 series, BX24 and BX25 tractor.

A	12 mm (0.47 in.)
B	25.4 mm (1.00 in.)
C	19 mm radius (0.75 in.) Hex.
D	2.7 mm (0.11 in.)
E	8 mm (0.31 in.)
F	15 mm dia. (0.59 in. dia.)
G	37 mm (1.46 in.)
H	70 mm (2.76 in.)
I	M14 ×1.5
J	R 3 mm (0.12 in.)
K	30 mm (1.18 in.)
L	17 mm (0.67 in.)
M	38 mm (1.50 in.)

W10301570

Disassembling and Assembling Stand (1/2)

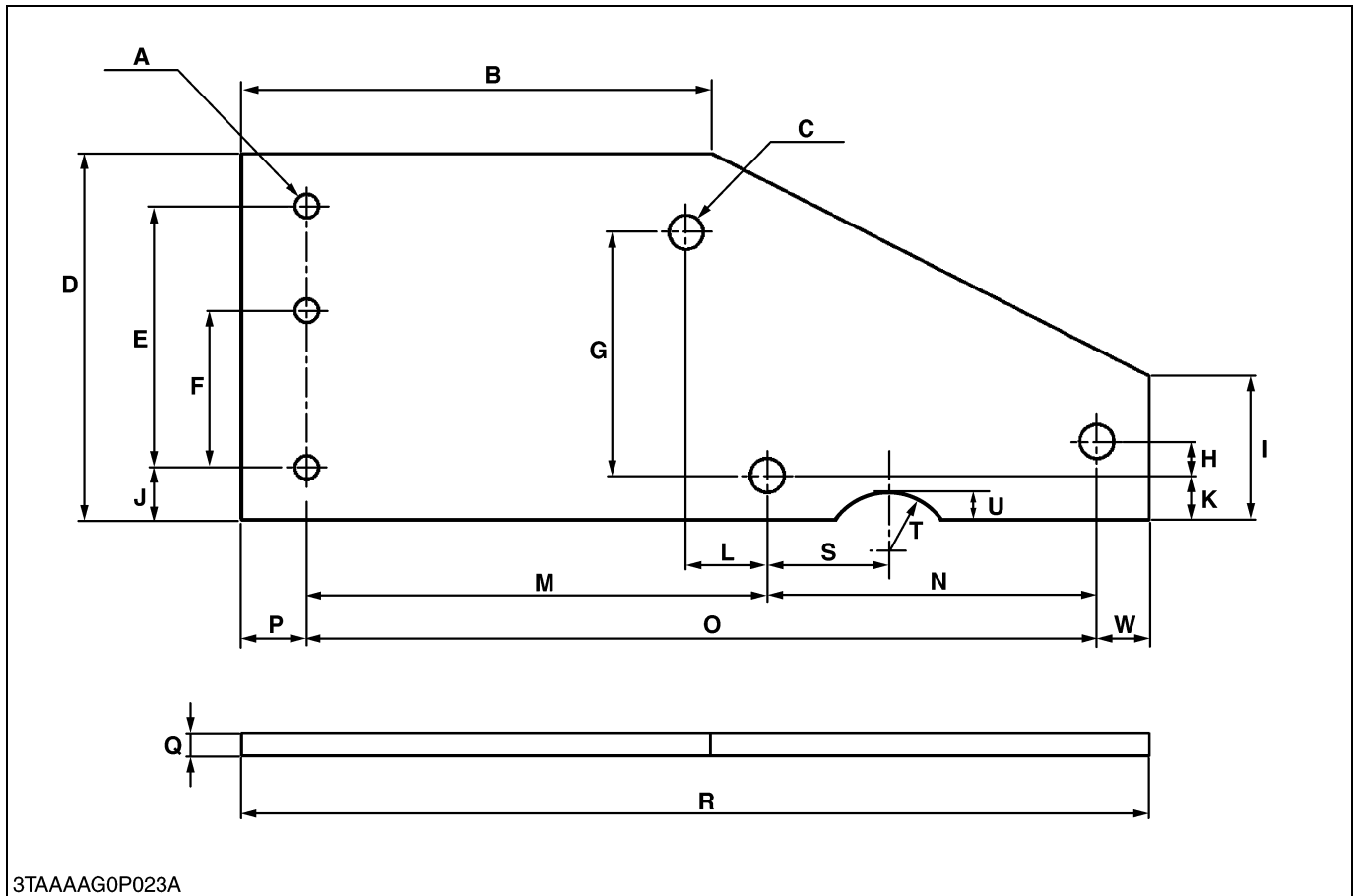

Application: Use to disassembling transaxle assembly and to assembling transaxle assembly.

A	φ 9 mm (φ 0.35 in.) 3 Holes	L	30.5 to 31.5 mm (1.21 to 1.24 in.)
B	225 mm (8.86 in.)	M	226 mm (8.90 in.)
C	φ 13 mm (φ 0.51 in.) 3 Holes	N	125.5 to 126.5 mm (4.95 to 4.98 in.)
D	140 mm (5.51 in.)	O	352 mm (13.86 in.)
E	99.5 to 100.5 mm (3.92 to 3.95 in.)	P	25 mm (0.98 in.)
F	59.5 to 60.5 mm (2.35 to 2.38 in.)	Q	9.5 mm (0.37 in.)
G	92.5 to 93.5 mm (3.65 to 3.68 in.)	R	397 mm (15.63 in.)
H	12.5 to 13.5 mm (0.50 to 0.53 in.)	S	46 mm (1.81 in.)
I	55 mm (2.17 in.)	T	R 25 mm (0.98 in.)
J	20 mm (0.79 in.)	U	11 mm (0.43 in.)
K	17 mm (0.67 in.)	W	20 mm (0.79 in.)

Disassembling and Assembling Stand (2/2)

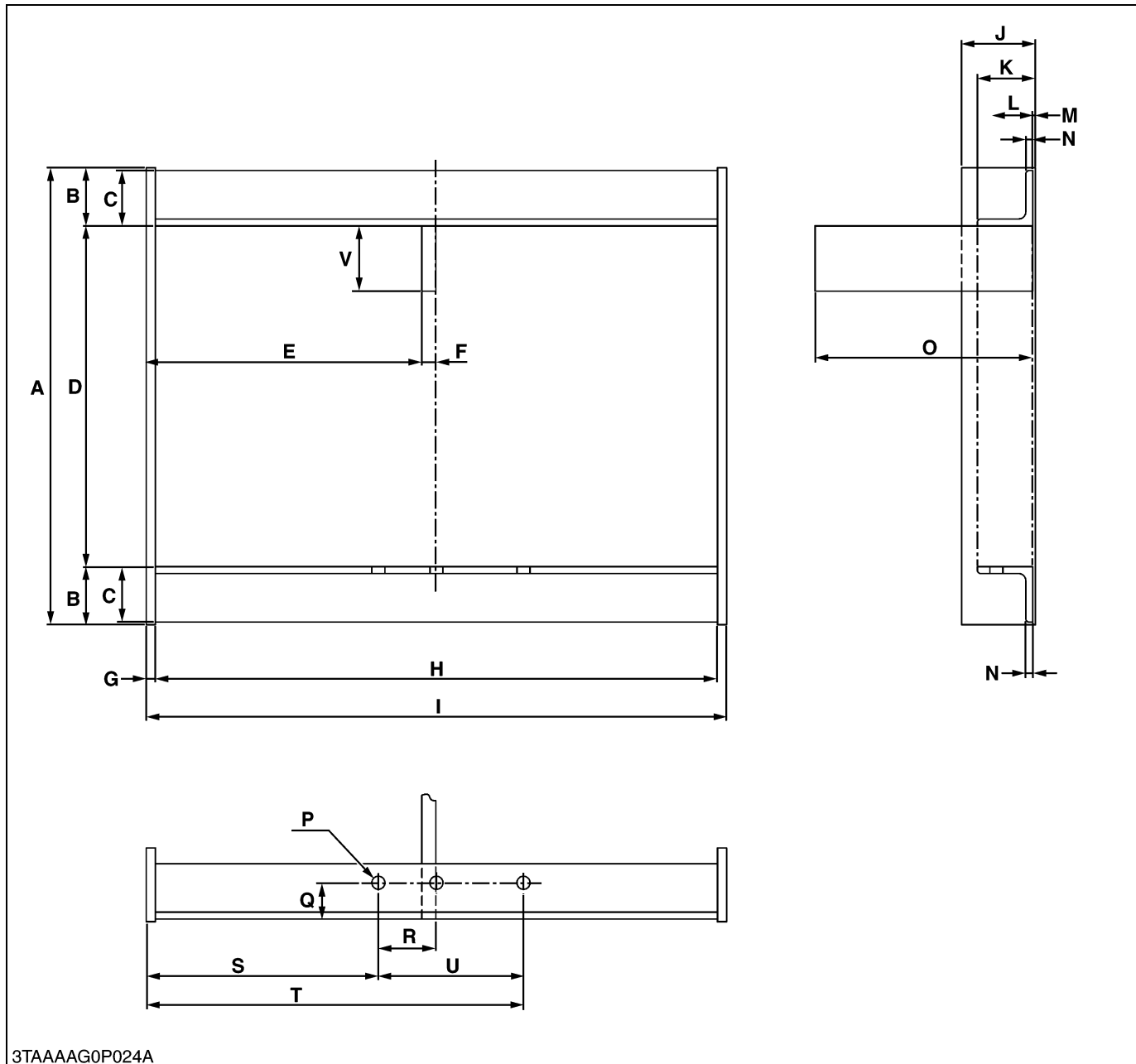

3TAAAAG0P024A

Application: Use to disassembling transaxle assembly and to assembling transaxle assembly.

A	311 mm (12.24 in.)	L	38.1 mm (1.50 in.)
B	40 mm (1.57 in.)	M	1.9 mm (0.07 in.)
C	38.1 mm (1.50 in.)	N	4.8 mm (0.19 in.)
D	235 mm (9.25 in.)	O	200 mm (7.87 in.)
E	170 mm (6.69 in.)	P	φ 9 mm (φ 0.35 in.), 3 Holes
F	9.5 mm (0.37 in.)	Q	25 mm (0.98 in.)
G	6.4 mm (0.25 in.)	R	39.5 to 40.5 mm (1.56 to 1.59 in.)
H	365 mm (14.37 in.)	S	140 mm (5.51 in.)
I	377.8 mm (14.87 in.)	T	260 mm (10.24 in.)
J	50.8 mm (2.00 in.)	U	99.5 to 100.5 mm (3.92 to 3.95 in.)
K	40 mm (1.57 in.)	V	45 mm (1.77 in.)

9. TIRES

[1] TIRE PRESSURE



WARNING

- Do not attempt to mount a tire on a rim. This should be done by a qualified person with the proper equipment.
- Always maintain the correct tire pressure.
Do not inflate tires above the recommended pressure shown in the operator's manual.

IMPORTANT

- Do not use tires larger than specified.
- When you intend to mount different size of tires from equipped ones, consult your distributor about front drive gear ratio for detail.
Excessive wear of tires may occur due to improper gear ratio.

[BX1860]

	Tire sizes	Inflation pressure
Rear	24 × 12.00 – 12 Turf	100 kPa (1.0 kgf/cm ² , 14 psi)
	24 × 12.00 – 12 Bar	120 kPa (1.2 kgf/cm ² , 17 psi)
Front	16 × 7.50 – 8 Turf	120 kPa (1.2 kgf/cm ² , 17 psi)
	16 × 7.50 – 8 Bar	150 kPa (1.5 kgf/cm ² , 22 psi)

[BX2360, BX2660]

	Tire sizes	Inflation pressure
Rear	26 × 12.00 – 12 Turf	100 kPa (1.0 kgf/cm ² , 14 psi)
	26 × 12.00 – 12 Bar	120 kPa (1.2 kgf/cm ² , 17 psi)
	26 × 12.00 – 12 Ind.	120 kPa (1.2 kgf/cm ² , 17 psi)
Front	18 × 8.50 – 10 Turf	120 kPa (1.2 kgf/cm ² , 17 psi)
	18 × 8.50 – 10 Bar	150 kPa (1.5 kgf/cm ² , 22 psi)
	18 × 8.50 – 10 Ind.	150 kPa (1.5 kgf/cm ² , 22 psi)

Though the tire pressure is factory-set to the prescribed level, it naturally drops slowly in the course of time. Thus, check it everyday and inflate as necessary.

NOTE

- Maintain the maximum pressure in front tires, if using a front loader or when equipped with a full load of front weights.

[2] WHEEL TREAD

(1) Front Wheels

Front tread can not be adjusted.

■ **IMPORTANT**

- Do not turn discs to obtain wider tread.

■ **NOTE**

- Use the tapered bolts for wheels with beveled or tapered holes.

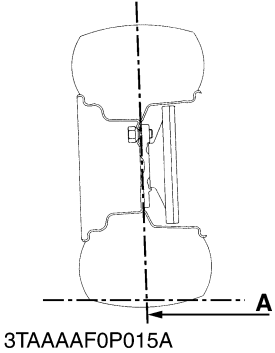
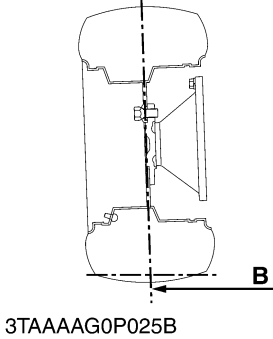
Models	BX1860	BX2360, BX2660
Tire	16 × 7.50 – 8 Turf, 16 × 7.50 – 8 Bar	18 × 8.50 – 10 Turf, 18 × 8.50 – 10 Bar, 18 × 8.50 – 10 Ind.
Tread	 <p>3TAAAAF0P015A</p>	 <p>3TAAAAG0P025B</p>

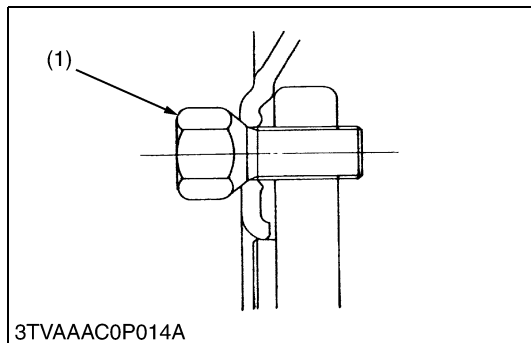

Tightening torque	Front wheel	149.2 to 179.0 N·m 15.2 to 18.3 kgf·m 110 to 132 lbf·ft
-------------------	-------------	---

(1) Wheel Mounting Screw

A : 880 mm (34.6 in.)

B : 910 mm (35.8 in.)

W1045824

(2) Rear Wheels

Rear tread can not be adjusted.

■ IMPORTANT

- Do not turn discs to obtain wider tread.
- Always attach tires as shown in the drawing.
- If not attached as illustrated, transmission parts may be damaged.
- When re-fitting or adjusting a wheel, tighten the bolts to the following torques then recheck after driving the tractor 200 m (200 yards) and thereafter daily check service.

■ NOTE

- Use the tapered bolts for wheels with beveled or tapered holes.

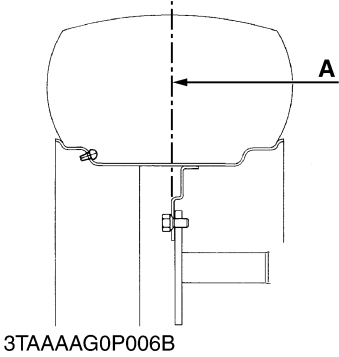
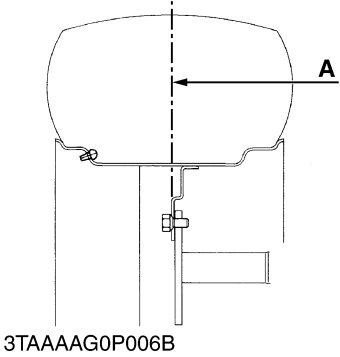
Models	BX1860	BX2360, BX2660
Tire	16 × 7.5 – 8 Turf, 16 × 7.5 – 8 Bar	26 × 12.00 – 12 Turf, 26 × 12.00 – 12 Bar, 26 × 12.00 – 12 Ind.
Tread	 <p>3TAAAAG0P006B</p>	 <p>3TAAAAG0P006B</p>

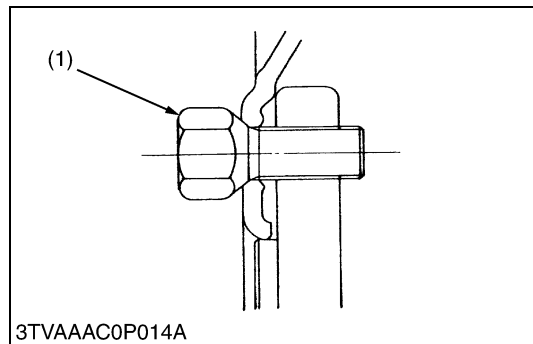

Tightening torque	Rear wheel	108.5 to 130.2 N·m 11.1 to 13.3 kgf·m 80 to 96 lbf·ft
-------------------	------------	---

(1) Wheel Mounting Screw

A : 820 mm (32.2 in.)

W1038060

[3] BALLAST

(1) Front Ballast

Add weights needed for stability and improve traction.

Heavy pulling and heavy rear mounted implements tend to lift front wheels. Add enough ballast to maintain steering control and prevent tip over.

Remove weight when no longer needed.

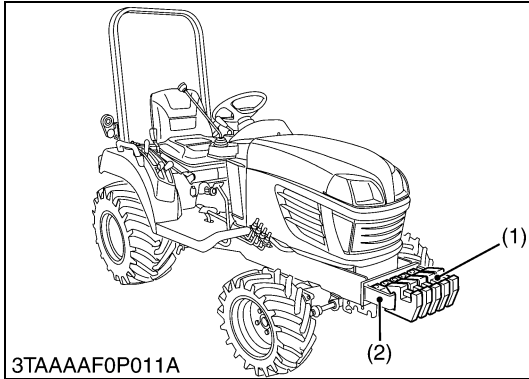

Front End Weights (Option)

1. The front end weights can be attached to the bumper.
See your implement operator's manual for required number of weights.

■ **NOTE**

- Besides the weight, a front weight bracket and mounting bolt kit(s) are required for mounting the weight.

■ **IMPORTANT**

- Do not overload tires.
- Add no more weight than indicated in chart.

Maximum weight	Factory spec.	125 kg 275 lbs
----------------	---------------	-------------------

(1) Front End Weights

(2) Front Weight Bracket (Option)

W1029958

(2) Rear Ballast

Add weights to rear wheels if needed to improve traction or for stability. The amount of rear ballast should be matched to job and the ballast should be removed when it is not needed.

The weight should be added to the tractor in the form of liquid ballast.

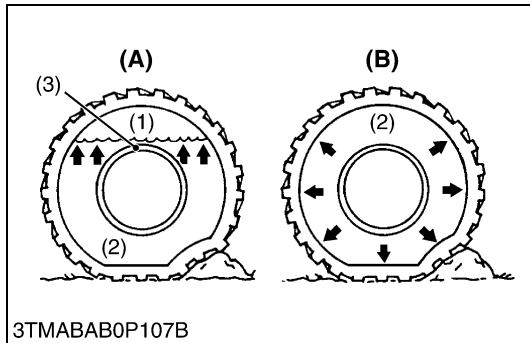

3TMABAB0P107B

Liquid Ballast in Rear Tires

1. Water and calcium chloride solution provides safe economical ballast. Used properly, it will not damage tires, tubes or rims.
2. The addition of calcium chloride is recommended to prevent the water from freezing.
3. Use of this method of weighting the wheels has the full approval of the tire companies.

■ IMPORTANT

- Do not fill tires with water or solution more than 75 % of full capacity (to the level of valve stem at 12 o'clock position).
- To avoid damage of transmission, do not use rear wheel weights and liquid ballast at the same time.

Tire sizes	26 x 12.00 - 12
Slush free at -10 °C (14 °F) Solid at -30 °C (-22 °F) [Approx. 1 kg (2 lbs) CaCl ₂ per 4 L (1 gal.) of water]	45 kg (99 lbs)
Slush free at -24 °C (-11 °F) Solid at -47 °C (-52 °F) [Approx. 1.5 kg (3.5 lbs) CaCl ₂ per 4 L (1 gal.) of water]	50 kg (110 lbs)
Slush free at -47 °C (-53 °F) Solid at -52 °C (-62 °F) [Approx. 2.25 kg (5 lbs) CaCl ₂ per 4 L (1 gal.) of water]	56 kg (123 lbs)

- (1) Air
- (2) Water
- (3) Valve Stem

**(A) Correct : 75 % Full Air
Compresses Like A Cushion**
**(B) Incorrect : 100 % Full
Water Can Not Be Compressed**

W1033435

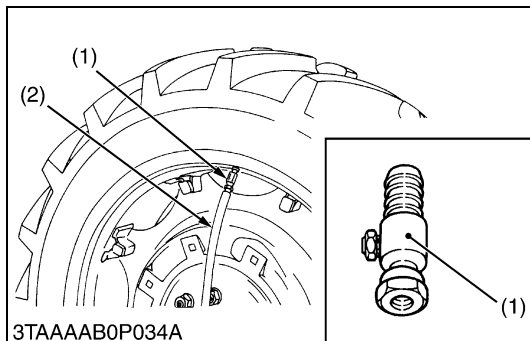

3TAAAB0P034A

Attaching Injector

1. Lift the rear tires off the ground.
2. Turn the tire so that the air valve is at the top.
3. Remove the air valve, and attach the injector. (Code No. 07916-52511)

- (1) Injector
- (2) Hose

W1033331

10. IMPLEMENT LIMITATIONS

The KUBOTA Tractor has been thoroughly tested for proper performance with implements sold or approved by KUBOTA. Use with implements which exceed the maximum specifications listed below, or which are otherwise unfit for use with the KUBOTA Tractor may result in malfunctions or failures of the tractor, damage to other property and injury to the operator or others. [Any malfunctions or failures of the tractor resulting from use with improper implements are not covered by the warranty.]

	Tread (max. width) with farm tires		Lower link end max. loading weight W_0
	Front	Rear	
BX1860	880 mm (34.6 in.)	820 mm (32.2 in.)	550 kg (1210 lbs)
BX2360	910 mm (35.8 in.)		
BX2660			

	Actual figures		
	Implement weight W_1 and / or size	Max. Drawbar Load W_2	Trailer loading weight W_3 Max. capacity
BX1860	As in the following list (Shown on the next page)	250 kg (550 lbs)	800 kg (1765 lbs)
BX2360			
BX2660			

Lower link end max. hydraulic lifting capacity W_0
 Implement weight..... The implement's weight which can be put on the lower link : W_1
 Max. drawbar load W_2
 Trailer loading weight The max. loading weight for trailer (without trailer's weight) : W_3

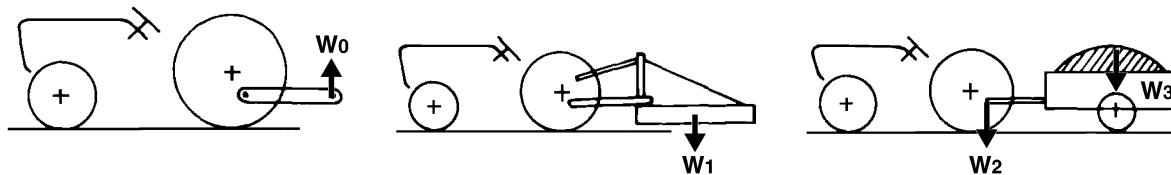

3TMABAB0P109A

■ **NOTE**

- Implement size may vary depending on soil operating conditions.

Implement		Remarks	BX1860	BX2360	BX2660
Mower	Mid-Mount	Max. Cutting Width	1370 mm (54 in.)	1520 mm (60 in.)	
		Max. Weight	95 kg (210 lbs)	115 kg (254 lbs)	140 kg (309 lbs)
	Rotary-Cutter (1 Blade)	Max. Cutting Width	1070 mm (42 in.)		
		Max. Weight	140 kg (300 lbs)		
	Rear-Mount (2 or 3 Blade)	Max. Cutting Width	1220 mm (48 in.)	1520 mm (60 in.)	
		Max. Weight	115 kg (250 lbs)	140 kg (300 lbs)	
	Flail Mower	Max. Cutting Width	1070 mm (42 in.)		
Sickle Bar	Max. Cutting Width	1220 mm (48 in.)			
Rotary Tiller		Max. Tilling Width	1070 mm (42 in.)		
		Max. Weight	170 kg (375 lbs)		
Bottom Plow	Max. Size	12 in. x 1	14 in. x 1		
Disc Plow	Max. Size	22 in. x 1			
Cultivator	Max. Width	1220 mm (48 in.) 1 Row			
Disc Harrow	Max. Harrowing Width	1220 mm (48 in.)	1370 mm (54 in.)		
	Max. Weight	120 kg (265 lbs)	140 kg (300 lbs)		
Sprayer	Max. Tank Capacity	150 L (40 U.S.gals, 33 Imp.gals)			
Front Blade	Max. Cutting Width	1370 mm (54 in.)	1520 mm (60 in.)		
	Sub Frame	Necessary			
Rear Blade	Max. Cutting Width	1370 mm (54 in.)	1520 mm (60 in.)		
	Max. Weight	140 kg (300 lbs)	160 kg (350 lbs)		
Front Loader	Max. Lifting Capacity	200 kg (440 lbs)	240 kg (530 lbs)		
	Max. Width	1220 mm (48 in.)			
Box Blade	Max. Cutting Width	1220 mm (48 in.)			
	Max. Weight	170 kg (375 lbs)			
Snow Blower (Front)	Max. Working Width	1270 mm (50 in.)			
	Max. Weight	160 kg (350 lbs)			
	Sub Frame	Necessary			
Post Hole Digger	Digging Depth	1140 mm (45 in.)			
Rotary Broom	Cleaning Width	1190 mm (47 in.)			
Trailer	Max. Load Capacity	800 kg (1765 lbs)			

NOTE

- Backhoe cannot be attached.
- Implement size may vary depending on soil operating conditions.
- Reduce speed and trailer loads when operating in slippery conditions or when operating on slopes and utilize front wheel drive.

W1012736

1 ENGINE

NOTICE

Regarding engine mechanism information, please refer ENGINE MECHANISM WSM (Code No. 9Y021-01876).

SERVICING

CONTENTS

1. TROUBLESHOOTING	1-S1
2. SERVICING SPECIFICATIONS	1-S4
[1] BX1860, BX2360.....	1-S4
[2] BX2660	1-S10
3. TIGHTENING TORQUES	1-S15
4. CHECKING, DISASSEMBLING AND SERVICING.....	1-S17
[1] CHECKING AND ADJUSTING	1-S17
(1) Engine Body.....	1-S17
(2) Lubricating System	1-S19
(3) Cooling System.....	1-S20
(4) Fuel System	1-S22
[2] DISASSEMBLING AND ASSEMBLING.....	1-S26
(1) Separating Engine	1-S26
(2) Removing Outer Parts	1-S29
(3) Cylinder Head and Valves	1-S29
(4) Gear Case and Timing Gears	1-S33
(5) Piston and Connecting Rod	1-S37
(6) Flywheel and Crankshaft	1-S39
[3] SERVICING	1-S41
(1) Cylinder Head and Valves	1-S41
(2) Timing Gears, Camshaft and Governor Gear	1-S49
(3) Piston and Connecting Rod	1-S53
(4) Crankshaft.....	1-S57
(5) Cylinder.....	1-S65
(6) Oil Pump (BX1860, BX2360)	1-S66
(7) Oil Pump (BX2660).....	1-S67

1. TROUBLESHOOTING

Symptom	Probable Cause	Solution	Reference Page
Engine Does Not Start	No fuel	Replenish fuel	G-7
	Air in the fuel system	Bleed	G-30
	Water in the fuel system	Change fuel and repair or replace fuel system	–
	Fuel pipe clogged	Clean	G-25
	Fuel filter clogged	Change	G-25
	Excessively high viscosity of fuel or engine oil at low temperature	Use specified fuel or engine oil	G-7
	Fuel with low cetane number	Use specified fuel	G-7
	Fuel leak due to loose injection pipe retaining nut	Tighten retaining nut	1-S30
	Incorrect injection timing	Adjust	1-S22
	Fuel camshaft worn	Replace	1-S36
	Injection nozzle clogged	Clean or replace	1-S30
	Injection pump malfunctioning	Replace	1-S35
	Seizure of crankshaft, camshaft, piston, cylinder or bearing	Repair or replace	1-S37, S40
	Compression leak from cylinder	Replace head gasket, tighten cylinder head screw, glow plug and nozzle holder	1-S31
	Improper valve timing	Correct or replace timing gear	1-S36
	Piston ring and cylinder worn	Replace	1-S38
Excessive valve clearance	Adjust	1-S18	
Starter Does Not Run	Battery discharged	Charge	G-18
	Starter malfunctioning	Repair or replace	6-S28
	Main switch malfunctioning	Repair or replace	6-S9
	Safety switches malfunctioning	Adjust or replace	6-S11
	Wiring disconnected	Connect	–
Engine Revolution Is Not Smooth	Fuel filter clogged or dirty	Replace	G-25
	Air cleaner clogged	Clean or replace	G-19
	Fuel leak due to loose injection pipe retaining nut	Tighten retaining nut	1-S30
	Injection pump malfunctioning	Replace	1-S35
	Incorrect nozzle injection pressure	Adjust	1-S24
	Injection nozzle stuck or clogged	Repair or replace	1-S30
	Governor malfunctioning	Repair	1-S35

W1014322

Symptom	Probable Cause	Solution	Reference Page
Either White or Blue Exhaust Gas Is Observed	Excessive engine oil	Reduce to specified level	G-13
	Piston ring and cylinder worn or stuck	Repair or replace	1-S38
	Incorrect injection timing	Adjust	1-S22
	Deficient compression	Check	1-S17
Either Black or Dark Gray Exhaust Gas Is Observed	Overload	Reduce the load	–
	Low grade fuel used	Use specified fuel	G-7
	Fuel filter clogged	Replace	G-25
	Air cleaner clogged	Clean or replace	G-19
	Deficient nozzle injection	Repair or replace nozzle	1-S30
Deficient Output	Incorrect injection timing	Adjust	1-S22
	Engine's moving parts seem to be seizing	Repair or replace	–
	Injection pump malfunctioning	Repair or replace	1-S35
	Deficient nozzle injection	Repair or replace nozzle	1-S30
	Compression leak	Replace head gasket, tighten cylinder head screws, glow plug and nozzle holder	1-S31
	Air cleaner dirty or clogged	Clean or replace	G-19
Excessive Lubricant Oil Consumption	Piston ring's gap facing the same direction	Shift ring gap direction	1-S38
	Oil ring worn or stuck	Replace	1-S38
	Piston ring groove worn	Replace piston	1-S38
	Valve stem and valve guide worn	Replace	1-S43
	Oil leaking due to defective seals or packing	Replace	–
Fuel Mixed into Lubricant Oil	Injection pump's plunger worn	Repair or replace	1-S35
	Deficient nozzle injection	Repair or replace nozzle	1-S30
	Injection pump broken	Replace	1-S35
Water Mixed into Lubricant Oil	Head gasket defective	Replace	1-S31
	Cylinder block or cylinder head flawed	Replace	–

W1014322

Symptom	Probable Cause	Solution	Reference Page
Low Oil Pressure	Engine oil insufficient	Replenish	G-7
	Oil strainer clogged	Clean	1-S33
	Oil filter clogged	Replace	G-13
	Relief valve stuck with dirt	Clean	1-S19
	Relief valve spring weaken or broken	Replace	1-S19
	Excessive oil clearance of crankshaft bearing	Replace	1-S40
	Excessive oil clearance of crankpin bearing	Replace	1-S37
	Excessive oil clearance of rocker arm	Replace	1-S31
	Oil passage clogged	Clean	–
	Different type of oil	Use specified type of oil	G-7
	Oil pump defective	Repair or replace	1-S34
High Oil Pressure	Different type of oil	Use specified type of oil	G-7
	Relief valve defective	Replace	1-S19
Engine Overheated	Engine oil insufficient	Replenish	1-S26
	Fan belt broken or elongated	Replace or adjust	G-20
	Coolant insufficient	Replenish	G-7
	Radiator net and radiator fin clogged with dust	Clean	–
	Inside of radiator corroded	Clean or replace	–
	Coolant flow route corroded	Clean or replace	G-27
	Radiator cap defective	Replace	1-S21
	Overload running	Reduce the load	–
	Head gasket defective	Replace	1-S31
	Incorrect injection timing	Adjust	1-S22
	Unsuitable fuel used	Use specified fuel	G-7
Battery Quickly Discharged	Battery electrolyte insufficient	Replenish distilled water and charge	G-17
	Fan belt slips	Adjust belt tension or replace	G-20
	Wiring disconnected	Connect	–
	Rectifier defective	Replace	–
	Alternator defective	Replace	–
	Battery defective	Replace	–

W1014322

W1014322

2. SERVICING SPECIFICATIONS

[1] BX1860, BX2360

ENGINE BODY

Item		Factory Specification	Allowable Limit
Valve Clearance (Cold)		0.145 to 0.185 mm 0.00571 to 0.00728 in.	–
Compression Pressure [BX1860]		2.85 to 3.23 MPa 29.0 to 33.0 kgf/cm ² 413 to 469 psi	2.26 MPa 23.0 kgf/cm ² 327 psi
Difference among Cylinders		–	10 % or less
Compression Pressure [BX2360]		3.53 to 4.02 MPa 36.0 to 41.0 kgf/cm ² 512 to 583 psi	2.55 MPa 26.0 kgf/cm ² 370 psi
Difference among Cylinders		–	10 % or less
Top Clearance		0.55 to 0.70 mm 0.022 to 0.027 in.	–
Cylinder Head Surface	Flatness	–	0.05 mm 0.002 in.
Valve Recessing	Intake and Exhaust	–0.10 to 0.10 mm –0.0039 to 0.0039 in.	0.30 mm 0.012 in.
Valve Stem to Valve Guide	Clearance	0.030 to 0.057 mm 0.0012 to 0.0022 in.	0.10 mm 0.0039 in.
Valve Stem	O.D.	5.968 to 5.980 mm 0.2350 to 0.2354 in.	–
Valve Guide	I.D.	6.010 to 6.025 mm 0.2367 to 0.2372 in.	–
Valve Face	Angle (Intake)	0.79 rad 45 °	–
	Angle (Exhaust)	0.79 rad 45 °	–
Valve Seat	Angle (Intake and exhaust)	0.79 rad 45 °	–
	Width	2.12 mm 0.0835 in.	–
Valve Spring	Free Length	31.3 to 31.8 mm 1.24 to 1.25 in.	28.4 mm 1.12 in.
	Tilt	–	1.2 mm 0.047 in.
	Setting Load	65 N / 27.0 mm 6.6 kgf / 27.0 mm 15 lbf / 1.06 in.	55 N / 27.0 mm 5.6 kgf / 27.0 mm 12 lbf / 1.06 in.

W10138740

ENGINE BODY (Continued)

Item		Factory Specification	Allowable Limit
Rocker Arm Shaft to Rocker Arm	Clearance	0.016 to 0.045 mm 0.00063 to 0.0017 in.	0.15 mm 0.0059 in.
Rocker Arm Shaft	O.D.	10.473 to 10.484 mm 0.41233 to 0.41275 in.	–
Rocker Arm	I.D.	10.500 to 10.518 mm 0.41339 to 0.41409 in.	–
Push Rod	Alignment	–	0.25 mm 0.0098 in.
Tappet to Tappet Guide	Clearance	0.016 to 0.052 mm 0.00063 to 0.0020 in.	0.10 mm 0.0039 in.
Tappet	O.D.	17.966 to 17.984 mm 0.70733 to 0.70803 in.	–
Tappet Guide	I.D.	18.000 to 18.018 mm 0.70867 to 0.70937 in.	–
Timing Gear			
Crank Gear to Idle Gear	Backlash	0.0430 to 0.124 mm 0.00170 to 0.00488 in.	0.15 mm 0.0059 in.
Idle Gear 1 to Cam Gear	Backlash	0.0470 to 0.123 mm 0.00185 to 0.00484 in.	0.15 mm 0.0059 in.
Idle Gear 1 to Injection Pump Gear	Backlash	0.0460 to 0.124 mm 0.00182 to 0.00488 in.	0.15 mm 0.0059 in.
Crank Gear to Oil Pump Drive Gear	Backlash	0.0410 to 0.123 mm 0.00162 to 0.00484 in.	0.15 mm 0.0059 in.
Idle Gear Shaft to Gear Bushing			
Idle Gear 1	Clearance	0.020 to 0.084 mm 0.00079 to 0.0021 in.	0.10 mm 0.0039 in.
Idle Gear Bushing	I.D.	20.000 to 20.051 mm 0.78741 to 0.78940 in.	–
Idle Gear Shaft 1	O.D.	19.967 to 19.980 mm 0.78611 to 0.78661 in.	–
Idle Gear			
Idle Gear 1	Side Clearance	0.20 to 0.51 mm 0.0079 to 0.020 in.	0.80 mm 0.031 in.
Camshaft	Side Clearance	0.15 to 0.31 mm 0.0059 to 0.012 in.	0.50 mm 0.020 in.
	Alignment	–	0.01 mm 0.0004 in.

W1013874

ENGINE BODY (Continued)

Item		Factory Specification	Allowable Limit
Cam Height	Intake	26.88 mm 1.058 in.	26.83 mm 1.056 in.
	Exhaust	26.88 mm 1.058 in.	26.83 mm 1.056 in.
Camshaft Journal to Cylinder Block Bore	Oil Clearance	0.050 to 0.091 mm 0.0020 to 0.0035 in.	0.15 mm 0.0059 in.
Camshaft Journal	O.D.	32.934 to 32.950 mm 1.2967 to 1.2972 in.	–
Cylinder Block Bore	I.D.	33.000 to 33.025 mm 1.2993 to 1.3001 in.	–
Piston Pin Bore	I.D.	20.000 to 20.013 mm 0.78741 to 0.78791 in.	20.05 mm 0.7894 in.
Piston Pin to Small End Bushing	Clearance	0.015 to 0.075 mm 0.0059 to 0.0029 in.	0.15 mm 0.0059 in.
Piston Pin	O.D.	20.002 to 20.011 mm 0.78748 to 0.78783 in.	–
Small End Bushing	I.D.	20.025 to 20.040 mm 0.78839 to 0.78897 in.	–
Piston Ring Gap [BX1860]	Top Ring	0.15 to 0.30 mm 0.0059 to 0.011 in.	1.2 mm 0.0472 in.
	Second Ring	0.30 to 0.45 mm 0.012 to 0.017 in.	1.25 mm 0.0492 in.
	Oil Ring	0.15 to 0.30 mm 0.0059 to 0.011 in.	1.2 mm 0.0472 in.
Piston Ring Gap [BX2360]	Top Ring	0.20 to 0.35 mm 0.0079 to 0.013 in.	1.25 mm 0.0492 in.
	Second Ring	0.35 to 0.50 mm 0.014 to 0.019 in.	1.25 mm 0.0492 in.
	Oil Ring	0.20 to 0.35 mm 0.0079 to 0.013 in.	1.25 mm 0.0492 in.
Piston Ring to Piston Ring Groove Second Ring	Clearance	0.0900 to 0.0120 mm 0.00355 to 0.00472 in.	0.15 mm 0.0059 in.
Oil Ring	Clearance	0.040 to 0.080 mm 0.0016 to 0.0031 in.	0.15 mm 0.0059 in.
Connecting Rod	Alignment	–	0.05 mm 0.002 in.
Crankshaft	Alignment	–	0.02 mm 0.0008 in.

W10138740

ENGINE BODY (Continued)

Item		Factory Specification	Allowable Limit
Crankshaft to Crankshaft Bearing 1 [BX1860]	Oil Clearance	0.0340 to 0.114 mm 0.00134 to 0.00448 in.	0.20 mm 0.0079 in.
	Crankshaft	O.D. 39.934 to 39.950 mm 1.5722 to 1.5728 in.	—
	Crankshaft Bearing 1	I.D. 39.984 to 40.040 mm 1.5742 to 1.5763 in.	—
Crankshaft to Crankshaft Bearing 1 [BX2360]	Oil Clearance	0.0340 to 0.106 mm 0.00134 to 0.00417 in.	0.20 mm 0.0079 in.
	Crankshaft Journal	O.D. 43.934 to 43.950 mm 1.7297 to 1.7303 in.	—
	Crankshaft Bearing 1	I.D. 43.984 to 44.040 mm 1.7317 to 1.7338 in.	—
Crankshaft to Crankshaft Bearing 2	Oil Clearance	0.028 to 0.059 mm 0.0011 to 0.0023 in.	0.20 mm 0.0079 in.
	Crankshaft Journal	O.D. 43.934 to 43.950 mm 1.7297 to 1.7303 in.	—
	Crankshaft Bearing 2	I.D. 43.978 to 43.993 mm 1.7315 to 1.7320 in.	—
Crankshaft to Crankshaft Bearing 3 [BX1860]	Oil Clearance	0.028 to 0.059 mm 0.0011 to 0.0023 in.	0.20 mm 0.0079 in.
	Crankshaft Journal	O.D. 39.934 to 39.950 mm 1.5722 to 1.5728 in.	—
	Crankshaft Bearing 3	I.D. 39.978 to 39.993 mm 1.5740 to 1.5745 in.	—
Crankshaft to Crankshaft Bearing 3 [BX2360]	Oil Clearance	0.028 to 0.059 mm 0.0011 to 0.0023 in.	0.20 mm 0.0079 in.
	Crankshaft Journal	O.D. 43.934 to 43.950 mm 1.7297 to 1.7303 in.	—
	Crankshaft Bearing 3	I.D. 43.978 to 43.993 mm 1.7315 to 1.7320 in.	—
Crankpin to Crankpin Bearing	Oil Clearance	0.020 to 0.051 mm 0.00079 to 0.0020 in.	0.15 mm 0.0059 in.
	Crankpin	O.D. 33.959 to 33.975 mm 1.3370 to 1.3375 in.	—
	Crankpin Bearing	I.D. 33.995 to 34.010 mm 1.3384 to 1.3389 in.	—

W10795780

ENGINE BODY (Continued)

Item		Factory Specification	Allowable Limit
Crankshaft	Side Clearance	0.15 to 0.31 mm 0.0059 to 0.012 in.	0.50 mm 0.020 in.
Cylinder Liner [BX1860]	I.D.	67.000 to 67.019 mm 2.6378 to 2.6385 in.	67.150 mm 2.6437 in.
Cylinder Liner [BX2360]	I.D.	72.000 to 72.019 mm 2.8347 to 2.8353 in.	72.150 mm 2.8406 in.
Cylinder (Oversized) [BX1860]		67.250 to 67.269 mm 2.6477 to 2.6483 in.	67.400 mm 2.6535 in.
Cylinder (Oversized) [BX2360]		72.250 to 72.269 mm 2.8445 to 2.8452 in.	72.400 mm 2.8504 in.

W10138740

LUBRICATING SYSTEM

Engine Oil Pressure	At Idle Speed	More than 49 kPa 0.50 kgf/cm ² 7.1 psi	–
	At Rated Speed	197 to 441 kPa 2.00 to 4.50 kgf/cm ² 28.5 to 64.0 psi	147 kPa 1.50 kgf/cm ² 21.3 psi
Inner Rotor to Outer Rotor	Clearance	0.030 to 0.14 mm 0.0012 to 0.0055 in.	–
Outer Rotor to Pump Body	Clearance	0.070 to 0.15 mm 0.0028 to 0.0059 in.	–
Inner Rotor to Cover	Clearance	0.0750 to 0.135 mm 0.00296 to 0.00531 in.	–

W10139730

COOLING SYSTEM

Item		Factory Specification	Allowable Limit
Fan Belt	Tension	7.0 to 9.0 mm / 98 N 0.28 to 0.35 in. / 98 N (10 kgf, 22 lbf)	–
Thermostat	Valve Opening Temperature (At Beginning)	69.5 to 72.5 °C 157.1 to 162.5 °F	–
	Valve Opening Temperature (Opened Completely)	85 °C 185 °F	–
Radiator Cap	Pressure Falling Time	10 seconds or more 88 → 59 kPa 0.90 → 0.60 kgf/cm ² 13 → 8.5 psi	–
Radiator	Water Leakage Test Pressure	No leak at specified pressure	–

W10135990

FUEL SYSTEM

Item		Factory Specification	Allowable Limit
Injection Pump	Injection Timing (3200 min ⁻¹ (rpm))	0.3360 to 0.3622 rad (19.25 to 20.75°) before T.D.C.	–
Pump Element	Fuel Tightness	–	13.73 MPa 140.0 kgf/cm ² 1991 psi
Delivery Valve	Fuel Tightness	10 seconds 13.73 → 12.75 MPa 140.0 → 130.0 kgf/cm ² 1991 → 1849 psi	5 seconds 13.73 → 12.75 MPa 140.0 → 130.0 kgf/cm ² 1991 → 1849 psi
Injection Nozzle	Injection Pressure	13.73 to 14.70 MPa 140.0 to 150.0 kgf/cm ² 1992 to 2133 psi	–
Injection Nozzle Valve Seat	Valve Seat Tightness	When the pressure is 12.75 MPa (130.0 kgf/cm ² , 1849 psi), the valve seat must be fuel tightness.	–

W10701990

[2] BX2660

ENGINE BODY

Item		Factory Specification	Allowable Limit
Valve Clearance (Cold)		0.145 to 0.185 mm 0.00571 to 0.00728 in.	–
Compression Pressure		3.73 to 4.11 MPa 38.0 to 42.0 kgf/cm ² 541 to 597 psi	2.26 MPa 23.0 kgf/cm ² 327 psi
Difference among Cylinders		–	10 % or less
Top Clearance		0.55 to 0.75 mm 0.022 to 0.029 in.	–
Cylinder Head Surface	Flatness	–	0.05 mm 0.002 in.
Valve Recessing	Intake and Exhaust	– 0.050 to 0.25 mm – 0.0020 to 0.0098 in.	0.40 mm 0.016 in.
Valve Stem to Valve Guide	Clearance	0.035 to 0.065 mm 0.0014 to 0.0025 in.	0.10 mm 0.0039 in.
Valve Stem	O.D.	6.960 to 6.975 mm 0.2741 to 0.2746 in.	–
Valve Guide	I.D.	7.010 to 7.025 mm 0.2760 to 0.2765 in.	–
Valve Face	Angle (Intake)	1.0 rad 60 °	–
	Angle (Exhaust)	0.79 rad 45 °	–
Valve Seat	Angle (Intake)	1.0 rad 60 °	–
	Angle (Exhaust)	0.79 rad 45 °	–
	Width	2.12 mm 0.0835 in.	–
Valve Spring	Free Length	37.0 to 37.5 mm 1.46 to 1.47 in.	36.5 mm 1.44 in.
	Tilt	–	1.0 mm 0.039 in.
	Setting Load	117.4 N / 31.0 mm 11.97 kgf / 31.0 mm 26.39 lbf / 1.22 in.	100.0 N / 31.0 mm 10.20 kgf / 31.0 mm 22.48 lbf / 1.22 in.

W10138740

ENGINE BODY (Continued)

Item		Factory Specification	Allowable Limit
Rocker Arm Shaft to Rocker Arm	Clearance	0.016 to 0.045 mm 0.00063 to 0.0017 in.	0.10 mm 0.0039 in.
Rocker Arm Shaft	O.D.	11.973 to 11.984 mm 0.47138 to 0.47181 in.	–
Rocker Arm	I.D.	12.000 to 12.018 mm 0.47244 to 0.47314 in.	–
Push Rod	Alignment	–	0.25 mm 0.0098 in.
Tappet to Tappet Guide	Clearance	0.020 to 0.062 mm 0.00079 to 0.0024 in.	0.07 mm 0.003 in.
Tappet	O.D.	19.959 to 19.980 mm 0.78579 to 0.78661 in.	–
Tappet Guide	I.D.	20.000 to 20.021 mm 0.78740 to 0.78822 in.	–
Timing Gear Crank Gear to Idle Gear 1	Backlash	0.0320 to 0.115 mm 0.00126 to 0.00452 in.	0.15 mm 0.0059 in.
Idle Gear 1 to Cam Gear	Backlash	0.0360 to 0.114 mm 0.00142 to 0.00448 in.	0.15 mm 0.0059 in.
Idle Gear 1 to Injection Pump Gear	Backlash	0.0340 to 0.116 mm 0.00134 to 0.00456 in.	0.15 mm 0.0059 in.
Governor Gear Governor Gear to Injection Pump Gear (Fuel Cam Gear)	Backlash	0.0300 to 0.117 mm 0.00119 to 0.00460 in.	0.15 mm 0.0059 in.
Idle Gear Shaft to Gear Bushing Idle Gear 1	Clearance	0.020 to 0.054 mm 0.00079 to 0.0021 in.	0.10 mm 0.0039 in.
Idle Gear Bushing	I.D.	26.000 to 26.021 mm 1.0237 to 1.0244 in.	–
Idle Gear Shaft 1	O.D.	25.967 to 25.980 mm 1.0224 to 1.0228 in.	–
Idle Gear Idle Gear 1	Side Clearance	0.20 to 0.51 mm 0.0079 to 0.020 in.	0.80 mm 0.031 in.
Camshaft	Side Clearance	0.070 to 0.22 mm 0.0028 to 0.0086 in.	0.30 mm 0.012 in.
	Alignment	–	0.01 mm 0.0004 in.

W1013874

ENGINE BODY (Continued)

Item		Factory Specification	Allowable Limit
Cam Height	Intake	28.80 mm 1.134 in.	28.75 mm 1.132 in.
	Exhaust	29.00 mm 1.142 in.	28.95 mm 1.140 in.
Camshaft Journal to Cylinder Block Bore	Oil Clearance	0.050 to 0.091 mm 0.0020 to 0.0035 in.	0.15 mm 0.0059 in.
Camshaft Journal	O.D.	35.934 to 35.950 mm 1.4148 to 1.4153 in.	–
Cylinder Block Bore	I.D.	36.000 to 36.025 mm 1.4174 to 1.4183 in.	–
Piston Pin Bore	I.D.	22.000 to 22.013 mm 0.86615 to 0.86665 in.	22.03 mm 0.8673 in.
Piston Pin to Small End Bushing	Clearance	0.014 to 0.038 mm 0.00056 to 0.0014 in.	0.15 mm 0.0059 in.
Piston Pin	O.D.	22.002 to 22.011 mm 0.86622 to 0.86657 in.	–
Small End Bushing	I.D.	22.025 to 22.040 mm 0.86713 to 0.86771 in.	–
Piston Ring Gap	Top Ring	0.30 to 0.45 mm 0.012 to 0.017 in.	1.25 mm 0.0492 in.
	Second Ring	0.30 to 0.45 mm 0.012 to 0.017 in.	1.25 mm 0.0492 in.
	Oil Ring	0.25 to 0.40 mm 0.0098 to 0.015 in.	1.25 mm 0.0492 in.
Piston Ring to Piston Ring Groove Second Ring	Clearance	0.0850 to 0.112 mm 0.00335 to 0.00440 in.	0.2 mm 0.008 in.
Oil Ring	Clearance	0.020 to 0.055 mm 0.00079 to 0.0021 in.	0.15 mm 0.0059 in.
Connecting Rod	Alignment	–	0.05 mm 0.002 in.
Crankshaft	Alignment	–	0.02 mm 0.0008 in.
Crankshaft to Crankshaft Bearing 1	Oil Clearance	0.0340 to 0.114 mm 0.00134 to 0.00448 in.	0.20 mm 0.0079 in.
Crankshaft	O.D.	47.934 to 47.950 mm 1.8872 to 1.8877 in.	–
Crankshaft Bearing 1	I.D.	47.984 to 48.048 mm 1.8892 to 1.8916 in.	–

W10138740

ENGINE BODY (Continued)

Item		Factory Specification	Allowable Limit
Crankshaft to Crankshaft Bearing 2	Oil Clearance	0.034 to 0.095 mm 0.0014 to 0.0037 in.	0.20 mm 0.0079 in.
Crankshaft Journal	O.D.	47.934 to 47.950 mm 1.8872 to 1.8877 in.	—
Crankshaft Bearing 2	I.D.	47.984 to 48.029 mm 1.8892 to 1.8908 in.	—
Crankshaft to Crankshaft Bearing 3	Oil Clearance	0.034 to 0.098 mm 0.0014 to 0.0038 in.	0.20 mm 0.0079 in.
Crankshaft Journal	O.D.	51.921 to 51.940 mm 2.0442 to 2.0448 in.	—
Crankshaft Bearing 3	I.D.	51.974 to 52.019 mm 2.0463 to 2.0479 in.	—
Crankpin to Crankpin Bearing	Oil Clearance	0.029 to 0.091 mm 0.0012 to 0.0035 in.	0.20 mm 0.0079 in.
Crankpin	O.D.	39.959 to 39.975 mm 1.5732 to 1.5738 in.	—
Crankpin Bearing	I.D.	40.040 to 40.050 mm 1.5764 to 1.5767 in.	—
Crankshaft	Side Clearance	0.15 to 0.31 mm 0.0059 to 0.012 in.	0.50 mm 0.020 in.
Cylinder Liner	I.D.	76.000 to 76.019 mm 2.9922 to 2.9928 in.	76.15 mm 2.998 in.
Cylinder (Oversized)		76.500 to 76.519 mm 3.0119 to 3.0125 in.	76.65 mm 3.018 in.

W10138740

LUBRICATING SYSTEM

Engine Oil Pressure	At Idle Speed	More than 49 kPa 0.50 kgf/cm ² 7.1 psi	—
	At Rated Speed	197 to 441 kPa 2.00 to 4.50 kgf/cm ² 28.5 to 64.0 psi	147 kPa 1.50 kgf/cm ² 21.3 psi
Inner Rotor to Outer Rotor	Clearance	0.060 to 0.18 mm 0.0024 to 0.0071 in.	—
Outer Rotor to Pump Body	Clearance	0.100 to 0.180 mm 0.00394 to 0.00708 in.	—
Inner Rotor to Cover	Clearance	0.025 to 0.075 mm 0.00099 to 0.0029 in.	—

W10139730

COOLING SYSTEM

Item		Factory Specification	Allowable Limit
Fan Belt	Tension	7.0 to 9.0 mm / 98 N 0.28 to 0.35 in. / 98 N (10 kgf, 22 lbf)	–
Thermostat	Valve Opening Temperature (At Beginning)	69.5 to 72.5 °C 157.1 to 162.5 °F	–
	Valve Opening Temperature (Opened Completely)	85 °C 185 °F	–
Radiator Cap	Pressure Falling Time	10 seconds or more 88 → 59 kPa 0.90 → 0.60 kgf/cm ² 13 → 8.5 psi	–
Radiator	Water Leakage Test Pressure	No leak at specified pressure	–

W10135990

FUEL SYSTEM

Item		Factory Specification	Allowable Limit
Injection Pump	Injection Timing (3200 min ⁻¹ (rpm))	0.3360 to 0.3622 rad (19.25 to 20.75°) before T.D.C.	–
Pump Element	Fuel Tightness	–	13.73 MPa 140.0 kgf/cm ² 1991 psi
Delivery Valve	Fuel Tightness	10 seconds 13.73 → 12.75 MPa 140.0 → 130.0 kgf/cm ² 1991 → 1849 psi	5 seconds 13.73 → 12.75 MPa 140.0 → 130.0 kgf/cm ² 1991 → 1849 psi
Injection Nozzle	Injection Pressure	13.73 to 14.70 MPa 140.0 to 150.0 kgf/cm ² 1992 to 2133 psi	–
Injection Nozzle Valve Seat	Valve Seat Tightness	When the pressure is 12.75 MPa (130.0 kgf/cm ² , 1849 psi), the valve seat must be fuel tightness.	–

W10443110

3. TIGHTENING TORQUES

Tightening torques of screws, bolts and nuts on the table below are especially specified.
(Tractor section for general use screws, bolts and nuts : See page G-9.)

Tractor Section

Item	N·m	kgf·m	lbf·ft
Front coupling mounting bolt	24 to 27	2.4 to 2.8	18 to 20
Engine mounting nut	24 to 27	2.4 to 2.8	18 to 20
Cushion mounting nut	24 to 27	2.4 to 2.8	18 to 20
Engine support mounting screw	48 to 55	4.9 to 5.7	36 to 41

W1012736

Engine Section

Item	Size x Pitch	N·m	kgf·m	lbf·ft
Cylinder head cover screw [BX1860, BX2360]	M6 x 1.0	9.81 to 11.2	1.00 to 1.15	7.24 to 8.31
Cylinder head cover screw [BX2660]	M6 x 1.0	7 to 8	0.7 to 0.9	5 to 6
Cylinder head screw [BX1860, BX2360]	M8 x 1.25	37.3 to 42.2	3.8 to 4.3	28 to 31
Cylinder head screw [BX2660]	M8 x 1.25	64 to 68	6.5 to 7.0	47 to 50
*Main bearing case screw 1 [BX1860, BX2360]	M6 x 1.0	13 to 15	1.3 to 1.6	9.4 to 11
*Main bearing case screw 1 [BX2660]	M7 x 1.0	30 to 34	3.0 to 3.5	22 to 25
*Main bearing case screw 2 [BX1860, BX2360]	M7 x 1.0	27 to 30	2.7 to 3.1	20 to 22
*Main bearing case screw 2 [BX2660]	M8 x 1.25	49 to 53	5.0 to 5.5	37 to 39
*Flywheel screw	M10 x 1.25	54 to 58	5.5 to 6.0	40 to 43
*Connecting rod screw [BX1860, BX2360]	M7 x 0.75	27 to 30	2.7 to 3.1	20 to 22
*Connecting rod screw [BX2660]	M7 x 0.75	42 to 46	4.2 to 4.7	31 to 33
*Rocker arm bracket screw [BX1860, BX2360]	M6 x 1.0	9.81 to 11.2	1.00 to 1.15	7.24 to 8.31
*Rocker arm bracket nut [BX2660]	M7 x 1.0	22 to 26	2.2 to 2.7	16 to 19
*Idle gear shaft mounting screw	M6 x 1.0	9.81 to 11.2	1.00 to 1.15	7.24 to 8.31
*Fan drive pulley screw [BX1860, BX2360]	M12 x 1.5	118 to 127	12.0 to 13.0	86.8 to 94.0
*Fan drive pulley screw [BX2660]	M14 x 1.5	236 to 245	24.0 to 25.0	174 to 180
Bearing case cover mounting screw	M6 x 1.0	9.81 to 11.2	1.00 to 1.15	7.24 to 8.31
Glow plug	M8 x 1.0	7.9 to 14	0.80 to 1.5	5.8 to 10
Nozzle holder assembly	M20 x 1.5	49 to 68	5.0 to 7.0	37 to 50
Nozzle holder	–	35 to 39	3.5 to 4.0	26 to 28
Oil pressure switch	PT 1/8	15 to 19	1.5 to 2.0	11 to 14
Injection pipe retaining nut	M12 x 1.5	25 to 34	2.5 to 3.5	18 to 25
Overflow pipe retaining nut	M12 x 1.5	20 to 24	2.0 to 2.5	15 to 18
Drain plug with copper gasket	M12 x 1.25	33 to 37	3.3 to 3.8	24 to 27
Oil filter joint	–	40 to 49	4.0 to 5.0	29 to 36

NOTE

- In removing and applying the bolts and nuts marked with “ * ”, a pneumatic wrench or similar pneumatic tool, if employed, must be used with enough care not to get them seized.
- For * marked screws, bolts and nuts on the table, apply engine oil to their threads and seats before tightening.
- The letter “M” in Size × Pitch means that the screw, bolt or nut dimension stands for metric. The size is the nominal outside diameter in mm of the threads. The pitch is the nominal distance in mm between two threads.

W1013236

4. CHECKING, DISASSEMBLING AND SERVICING

[1] CHECKING AND ADJUSTING

(1) Engine Body

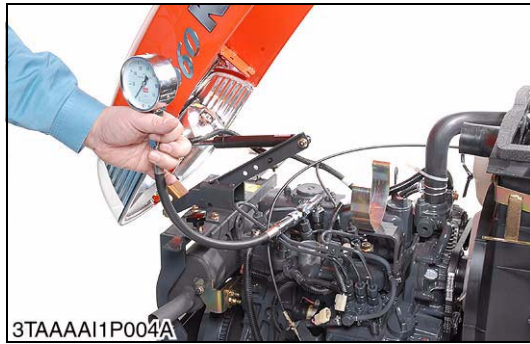

Compression Pressure

1. Run the engine until it is warmed up.
2. Stop the engine.
3. Remove the air cleaner, the muffler and all glow plugs (or nozzles).
4. Set a compression tester with the adaptor to the glow plug hole (or nozzle hole).
Nozzle hole : Adaptor **H** (07909-31231)
Glow plug hole : Adaptor **L** (07909-31301)
5. Disconnect the connector of engine stop solenoid and keep the engine stop position (non-injection). Then, run the engine with the starter and measure the compression pressure.
6. Repeat steps 4 and 5 for each cylinder.
7. If the measurement is below the allowable limit, apply a small amount of oil to the cylinder wall through the glow plug hole (or nozzle hole) and measure the compression pressure again.
8. If the compression pressure is still less than the allowable limit, check the top clearance, valve clearance and cylinder head.
9. If the compression pressure increases after applying oil, check the cylinder wall and piston rings.

■ NOTE

- Check the compression pressure with the specified valve clearance.
- Always use a fully charged battery for performing this test.
- Variances in cylinder compression values should be under 10 %.

[BX1860]

Compression pressure	Factory spec.	2.85 to 3.23 MPa 29.0 to 33.0 kgf/cm ² 413 to 469 psi
	Allowable limit	2.26 MPa 23.0 kgf/cm ² 327 psi

[BX2360]

Compression pressure	Factory spec.	3.53 to 4.02 MPa 36.0 to 41.0 kgf/cm ² 512 to 583 psi
	Allowable limit	2.55 MPa 26.0 kgf/cm ² 370 psi

[BX2660]

Compression pressure	Factory spec.	3.73 to 4.11 MPa 38.0 to 42.0 kgf/cm ² 541 to 597 psi
	Allowable limit	2.26 MPa 23.0 kgf/cm ² 327 psi

W10178940

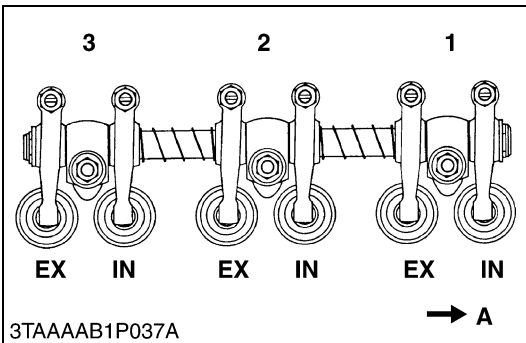
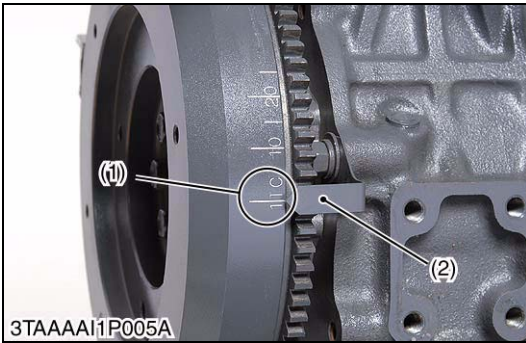
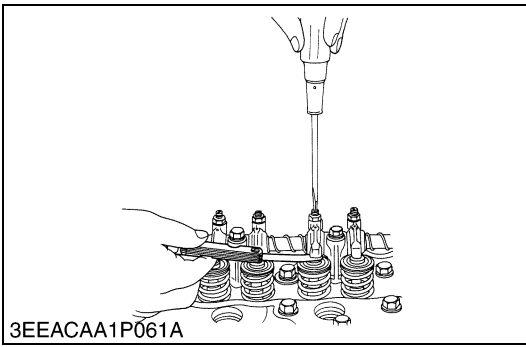

Checking Valve Clearance

■ IMPORTANT

- **Valve clearance must be checked and adjusted when engine is cold.**

1. Remove the cylinder head cover and the glow plugs.
2. Align the “1TC” mark (1) on the flywheel and alignment mark (2) on the rear end plate so that the No. 1 piston comes to the compression top dead center.
3. Check the following valve clearance marked with “★” using a feeler gauge.
4. If the clearance is not within the factory specifications, adjust with the adjusting screw.
5. Then turn the flywheel 6.28 rad (360 °), and align the “1TC” mark (1) on the flywheel and alignment mark (3) on the rear end plate so that the No. 1 piston comes to the overlap position.
6. Check the following valve clearance marked with “☆” using a feeler gauge.
7. If the clearance is not within the factory specifications, adjust with the adjusting screw.

Number of cylinders Valve arrangement Adjustable cylinder location of piston	Intake valve	Exhaust valve
	No. 1	★
No. 2	☆	★
No. 3	★	☆

Valve clearance marked with “★” can be adjusted.

Intake and exhaust valve clearance (cold)	Factory spec.	0.145 to 0.185 mm 0.00571 to 0.00728 in.
---	---------------	---

■ NOTE

- **The sequence of cylinder numbers is given as No. 1, No. 2 and No. 3 starting from the gear case side.**
- **After adjusting the valve clearance, secure the adjusting screw with the lock nut.**

- (1) “1TC” Mark
(2) Alignment Mark

A : Gear Case Side

W10172470

(2) Lubricating System



Engine Oil Pressure

1. Remove the engine oil pressure switch, and set an oil pressure tester.
2. Start the engine. After warming up, measure the oil pressure of both idling and rated speeds.
3. If the oil pressure is less than the allowable limit, check the following.
 - Engine oil insufficient
 - Oil pump defective
 - Oil strainer clogged
 - Oil filter cartridge clogged
 - Oil gallery clogged
 - Excessive oil clearance
 - Foreign matter in the relief valve

Engine oil pressure	At idle speed	Factory spec.	More than 49 kPa 0.50 kgf/cm ² 7.1 psi
	At rated speed	Factory spec.	197 to 441 kPa 2.00 to 4.50 kgf/cm ² 28.5 to 64.0 psi
		Allowable limit	147 kPa 1.50 kgf/cm ² 21.3 psi

(When reassembling)

- After checking the engine oil pressure, tighten the engine oil pressure switch to the specified torque.

Tightening torque	Oil pressure switch	15 to 19 N·m 1.5 to 2.0 kgf·m 11 to 14 lbf·ft
-------------------	---------------------	---

W10349520

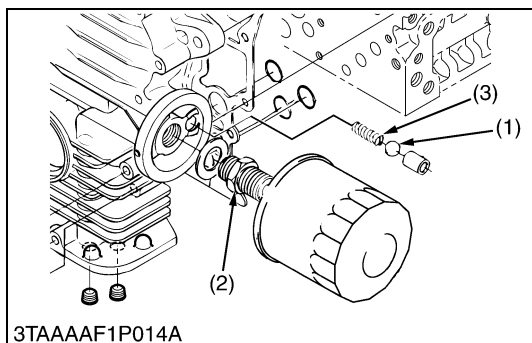
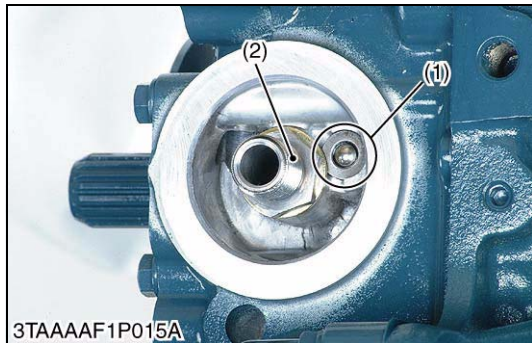

Relief Valve

1. Remove the oil filter base
2. Check the relief valve for dirt, and the seat and ball for damage.
3. If damaged, replace.
4. Check the free length of spring.
5. If less than the allowable limit, replace.

Relief valve spring	Factory spec.	32 mm 1.26 in.
	Allowable limit	28 mm 1.10 in.

Tightening torque	Joint	40 to 49 N·m 4.0 to 5.0 kgf·m 29 to 36 lbf·ft
-------------------	-------	---

- (1) Relief Valve
(2) Joint

- (3) Spring

W10756890

(3) Cooling System

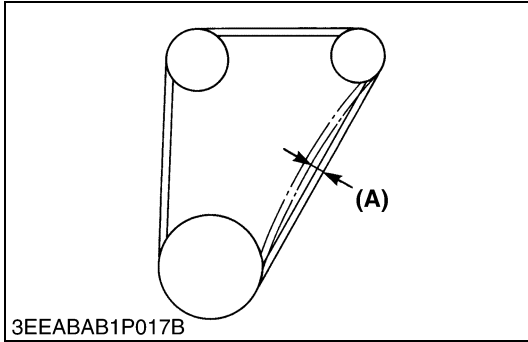

Fan Belt Tension

1. Measure the deflection **(A)**, depressing the belt halfway between the fan drive pulley and alternator pulley at specified force 98 N (10 kgf, 22 lbf).
2. If the measurement is not within the factory specifications, loosen the alternator mounting screws and relocate the alternator to adjust.

Deflection (A)	Factory spec.	7.0 to 9.0 mm 0.28 to 0.35 in.
-----------------------	---------------	-----------------------------------

(A) Deflection

W10356670

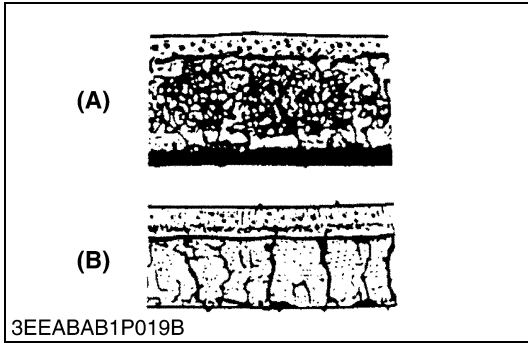

Fan Belt Damage and Wear

1. Check the fan belt for damage.
2. If the fan belt is damaged, replace it.
3. Check if the fan belt is worn and sunk in the pulley groove.
4. If the fan belt is nearly worn out and deeply sunk in the pulley groove, replace it.

(A) Good

(B) Bad

W1016443

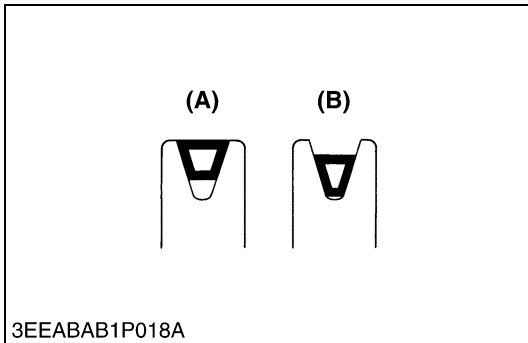

CAUTION

- When removing the radiator cap, wait at least ten minutes after the engine has stopped and cooled down. Otherwise, hot water may gush out, scalding nearby people.

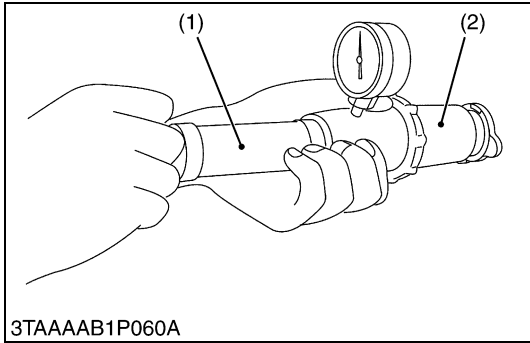

Radiator Cap Air Leakage

- Set a radiator tester (1) and an adaptor (2) on the radiator cap.
- Apply the specified pressure 88 kPa (0.90 kgf/cm², 13 psi), and measure the time for the pressure to fall to 59 kPa (0.60 kgf/cm², 8.5 psi).
- If the measurement is less than the factory specification, replace the radiator cap.

Pressure falling time	Factory spec.	More than 10 seconds for pressure fall 88 → 59 kPa (0.90 → 0.60 kgf/cm ² , 13 → 8.5 psi)
-----------------------	---------------	--

(1) Radiator Tester

(2) Adaptor

W1054156

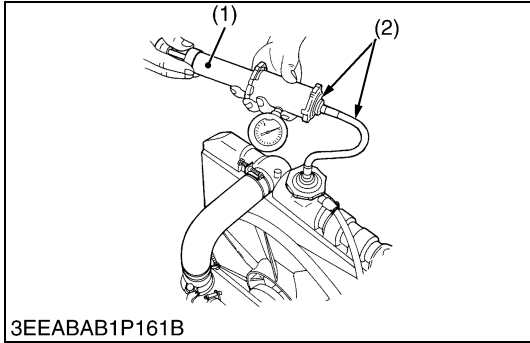

Radiator Water Leakage

- Pour a specified amount of water into the radiator.
- Set a radiator tester (1) and an adaptor (2) and raise the water pressure to the specified pressure.
- Check the radiator for water leaks.
- For water leak from the pinhole, repair with the radiator cement. When water leak is excessive, replace the radiator.

Radiator water leakage test pressure	Factory spec.	No leak at specified pressure
--------------------------------------	---------------	-------------------------------

NOTE

- The pressure of the leak test is different from each radiator specification. Thus, do the leak test, refer to the test pressure of each radiator specification.

(1) Radiator Tester

(2) Adaptor

W1016903

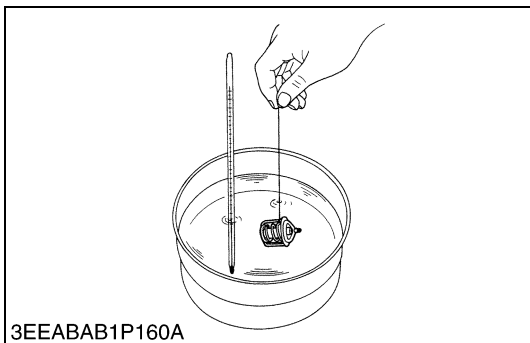

Thermostat Valve Opening Temperature

- Suspend the thermostat in the water by a string with its end inserted between the valve and seat.
- Heating the water gradually, read the temperature when the valve opens and leaves the string.
- Continue heating and read the temperature when the valve opens approx. 8 mm (0.3 in.).
- If the measurement is not within the factory specifications, replace the thermostat.

Thermostat's valve opening temperature	Factory spec.	69.5 to 72.5 °C 157.1 to 162.5 °F
Temperature at which thermostat completely opens	Factory spec.	85 °C 185 °F

W1035849

(4) Fuel System

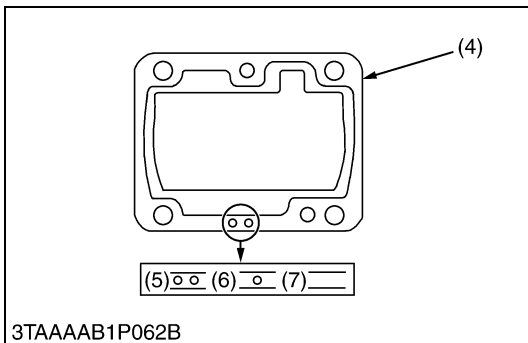
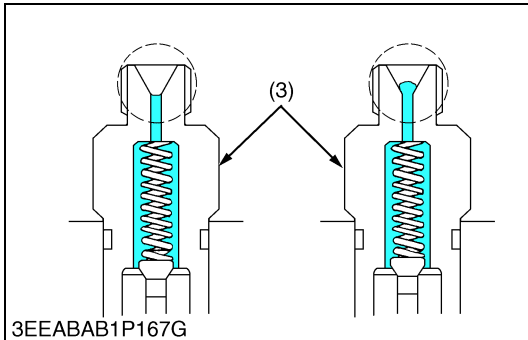
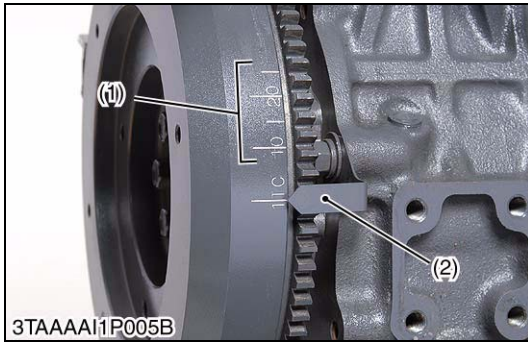

Injection Timing

1. Remove the injection pipes.
2. Remove the engine stop solenoid.
3. Turn the flywheel counterclockwise (viewed from flywheel side) until the fuel fills up to the hole of the delivery valve holder (3) for No. 1 cylinder.
4. After the fuel fills up to the hole of the delivery valve holder for No. 1 cylinder, turn back (clockwise) the flywheel around 1.6 rad (90 °).
5. Turn the flywheel counterclockwise to set at around 0.44 rad (25 °) before T.D.C..
6. Slowly turn the flywheel counterclockwise and stop turning when the fuel begins to come up, to get the present injection timing.
7. Check to see the degree on flywheel.
The flywheel gas mark "1TC", "10" and "20" for the crank angle before the top dead center of No. 1 cylinder.
8. If injection timing is out of adjustment, readjust the timing with shims.

Injection timing (3200 min ⁻¹ (rpm))	Factory spec.	0.3360 to 0.3622 rad (19.25 to 20.75 °) before T.D.C.
--	---------------	---

NOTE

- The liquid gasket is not required for assembling.
- Shims are available in thickness of 0.20 mm (0.0079 in.), 0.25 mm (0.0098 in.), 0.30 mm (0.012 in.) and 0.175 mm (0.00689 in.). Combine these shims for adjustments.
- Addition or reduction of shim (0.05 mm, 0.002 in.) delays or advances the injection timing by approx. 0.009 rad (0.5 °).
- In disassembling and replacing the injection pump, be sure to use the same number of new shims with the same thickness.
- The 0.175 mm thick shim is coated only on the lower face. Therefore, do not use the 0.175 mm thick shim as the top shim of the combination (injection pump side), because this can cause oil leakage.

- | | |
|-----------------------------------|--|
| (1) Timing Line | (5) Two-holes : 0.20 mm (0.0079 in.) |
| (2) Alignment Mark | Two-holes : 0.175 mm (0.00689 in.) |
| (3) Delivery Valve Holder | (6) One-hole : 0.25 mm (0.0098 in.) |
| (4) Shim (Soft Metal Gasket Shim) | (7) Without hole : 0.30 mm (0.012 in.) |

W1017170

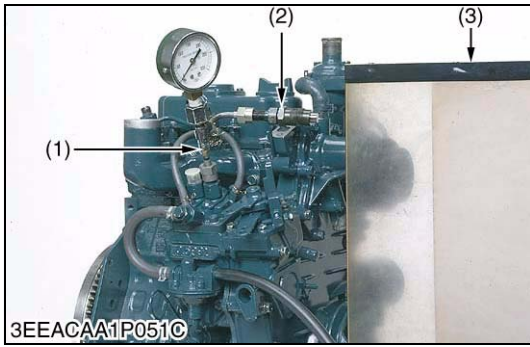

Fuel Tightness of Pump Element

1. Remove the engine stop solenoid.
2. Remove the injection pipes and glow plugs.
3. Install the injection pump pressure tester to the injection pump.
4. Install the injection nozzle (2) jetted with the proper injection pressure to the injection pump pressure tester (1). (Refer to the photo.)
5. Set the speed control lever to the maximum speed position.
6. Run the starter to increase the pressure.
7. If the pressure can not reach the allowable limit, replace the pump with new one or repair with a Kubota-authorized pump service shop.

Fuel tightness of pump element	Allowable limit	13.73 MPa 140.0 kgf/cm ² 1991 psi
--------------------------------	-----------------	--

NOTE

- **Never try to disassemble the injection pump assembly. For repairs, you are strongly requested to contact a Kubota-authorized pump service shop.**

- (1) Injection Pump Pressure Tester (3) Protection Cover for Jetted Fuel
(2) Injection Nozzle

W1017430

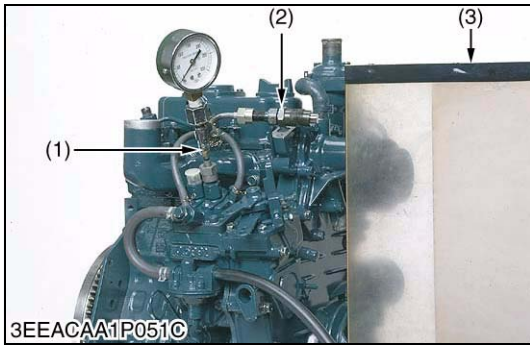

Fuel Tightness of Delivery Valve

1. Remove the engine stop solenoid.
2. Remove the injection pipes and glow plugs.
3. Set a pressure tester to the fuel injection pump.
4. Install the injection nozzle (2) jetted with the proper injection pressure to the injection pump pressure tester (1).
5. Run the starter to increase the pressure.
6. Stop the starter when the fuel jets from the injection nozzle. After that, turn the flywheel by the hand and raise the pressure to approx. 13.73 MPa (140.0 kgf/cm², 1991 psi).
7. Now turn the flywheel back about half a turn (to keep the plunger free). Maintain the flywheel at this position and clock the time taken for the pressure to drop from 13.73 to 12.75 MPa (from 140.0 to 130.0 kgf/cm², from 1991 to 1849 psi).
8. Measure the time needed to decrease the pressure from 13.73 to 12.75 MPa (140.0 to 130.0 kgf/cm², 1991 to 1849 psi).
9. If the measurement is less than allowable limit, replace the pump with new one or repair with a Kubota-authorized pump service shop.

Fuel tightness of delivery valve	Factory spec.	10 seconds 13.73 → 12.75 MPa 140.0 → 130.0 kgf/cm ² 1991 → 1849 psi
	Allowable limit	5 seconds 13.73 → 12.75 MPa 140.0 → 130.0 kgf/cm ² 1991 → 1849 psi

NOTE

- **Never try to disassemble the injection pump assembly. For repairs, you are strongly requested to contact a Kubota-authorized pump service shop.**

- (1) Injection Pump Pressure Tester (3) Protection Cover for Jetted Fuel
(2) Injection Nozzle

W1017786

CAUTION

- Check the nozzle injection pressure and condition after confirming that there is nobody standing in the direction the fume goes. If the fume from the nozzle directly contacts the human body, cells may be destroyed and blood poisoning may be caused.

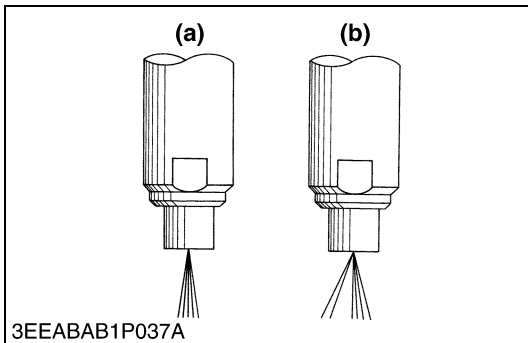

Nozzle Spraying Condition

1. Set the injection nozzle to a nozzle tester, and check the nozzle spraying condition.
2. If the spraying condition is defective, replace the nozzle piece.

(a) Good

(b) Bad

W10181310

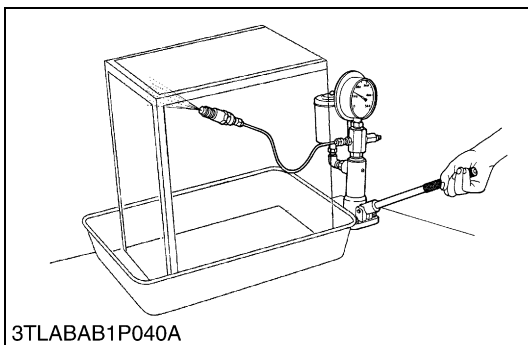

Fuel Injection Pressure

1. Set the injection nozzle to a nozzle tester.
2. Slowly move the tester handle to measure the pressure at which fuel begins jetting out from the nozzle.
3. If the measurement is not within the factory specifications, replace the adjusting washer (1) in the nozzle holder to adjust it.

(Reference)

- Pressure variation with 0.01 mm (0.0004 in.) difference of adjusting washer thickness.
Approx. 235 kPa (2.4 kgf/cm², 34 psi)

Fuel injection pressure	Factory spec.	13.73 to 14.70 MPa 140.0 to 150.0 kgf/cm ² 1992 to 2133 psi
-------------------------	---------------	--

(1) Adjusting Washer

W10182100

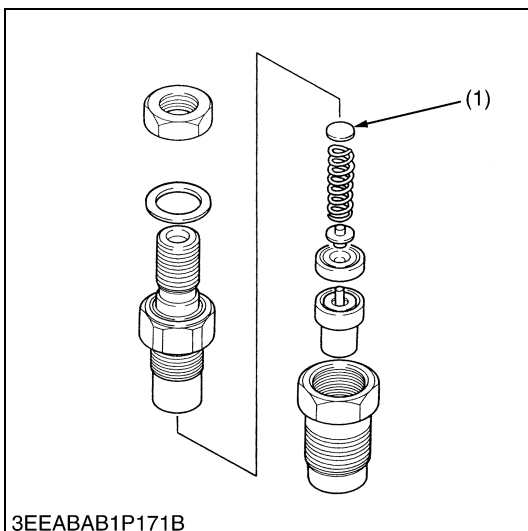

Valve Seat Tightness

1. Set the injection nozzle to a nozzle tester.
2. Raise the fuel pressure, and keep at 12.75 MPa (130.0 kgf/cm², 1849 psi) for 10 seconds.
3. If any fuel leak is found, replace the nozzle piece.

Valve seat tightness	Factory spec.	No fuel leak at 12.75 MPa 130.0 kgf/cm ² 1849 psi
----------------------	---------------	---

W10183690

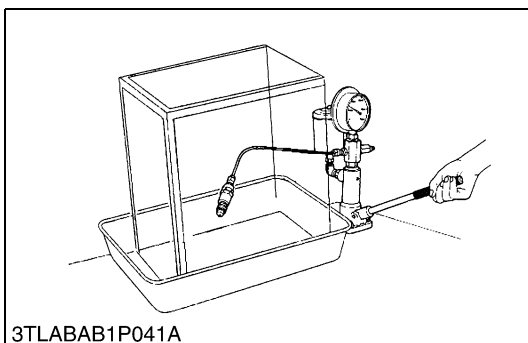

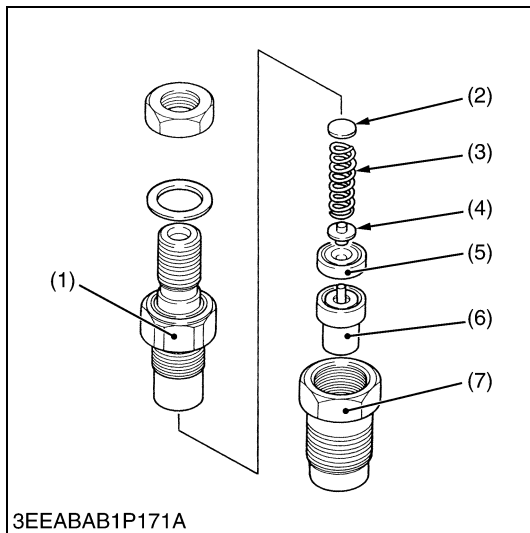

Nozzle Holder

1. Secure the nozzle retaining nut (7) with a vise.
2. Remove the nozzle holder (1), and take out parts inside.

(When reassembling)

- Assemble the nozzle in clean fuel oil.
- Install the push rod (4), noting its direction.
- After assembling the nozzle, be sure to adjust the fuel injection pressure.

Tightening torque	Nozzle holder	35 to 39 N·m 3.5 to 4.0 kgf·m 26 to 28 lbf·ft
	Overflow pipe retaining nut	20 to 24 N·m 2.0 to 2.5 kgf·m 15 to 18 lbf·ft
	Nozzle holder assembly	49 to 68 N·m 5.0 to 7.0 kgf·m 36 to 50 lbf·ft

- | | |
|----------------------|--------------------------|
| (1) Nozzle Holder | (5) Distance Piece |
| (2) Adjusting Washer | (6) Nozzle Piece |
| (3) Nozzle Spring | (7) Nozzle Retaining Nut |
| (4) Push Rod | |

W1018491

[2] DISASSEMBLING AND ASSEMBLING

(1) Separating Engine

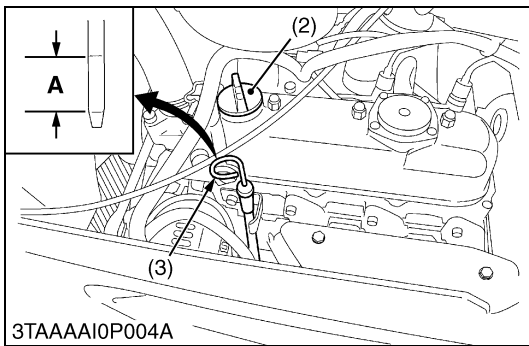
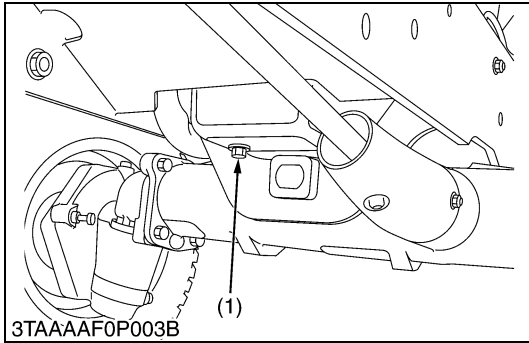

Draining Engine Oil

1. Start and warm up the engine for approx. 5 minutes.
2. Place an oil pan underneath the engine.
3. Remove the drain plug (1) to drain oil.
4. After draining, screw in the drain plug (1).

(When refilling)

- Fill the engine oil up to the upper line on the dipstick (3).

■ IMPORTANT

- **Never mix two different type of oil.**
- **Use the proper SAE Engine Oil according to ambient temperature.**

Refer to “LUBRICANTS, FUEL AND COOLANT” (See page G-7.).

Engine oil	Capacity	BX1860	2.9 L 3.1 U.S.qts 2.6 Imp.qts
		BX2360	3.1 L 3.3 U.S.qts 2.7 Imp.qts
		BX2660	3.5 L 3.7 U.S.qts 3.1 Imp.qts

- (1) Drain Plug
- (2) Oil Inlet
- (3) Dipstick

(A) Oil level is acceptable within this range

W1023464



Battery Cables and Battery

⚠ CAUTION

- **When disconnecting the battery cables, disconnect the negative cable from the battery first. When connecting, connect the positive cable to the battery first.**

1. Remove the under panel.
2. Disconnect the negative cable (2) from the battery (1).
3. Disconnect the positive cable (3) from the battery (1) and remove the battery (1).

- (1) Battery
- (2) Negative cable

(3) Positive Cable

W1045893



Bonnet and Under Cover

1. Open the bonnet (1), and then loosen the knob bolts and pull forward to remove the under cover (2).
2. Disconnect the connectors (3) for head light and remove the bonnet bracket (4) with bonnet.

- | | |
|-----------------|--------------------|
| (1) Bonnet | (3) Connector |
| (2) Under Cover | (4) Bonnet Bracket |

W1064425

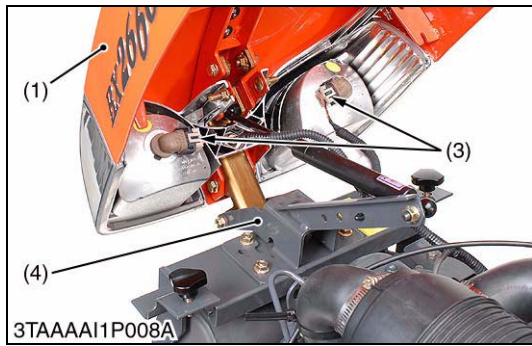

Accelerator Wire, Bonnet Post, Fuel Hoses, Wiring Harness and Others

1. Disconnect the wiring harness (4) from coolant temperature switch, stop solenoid, glow plug, starter motor, engine oil switch, alternator and ground cable.
2. Disconnect the accelerator wire (2) and fuel hoses (3).
3. Remove the bonnet post (1).

- | | |
|----------------------|--------------------|
| (1) Bonnet Post | (3) Fuel Hose |
| (2) Accelerator Wire | (4) Wiring Harness |

W1023496

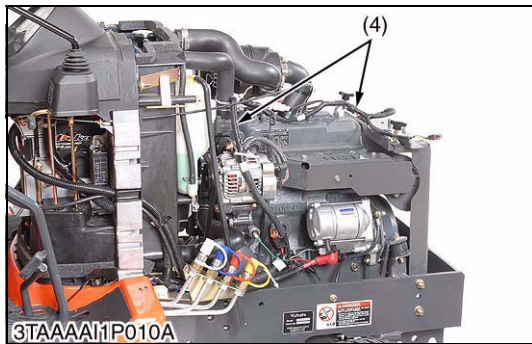

(2) Removing Outer Parts

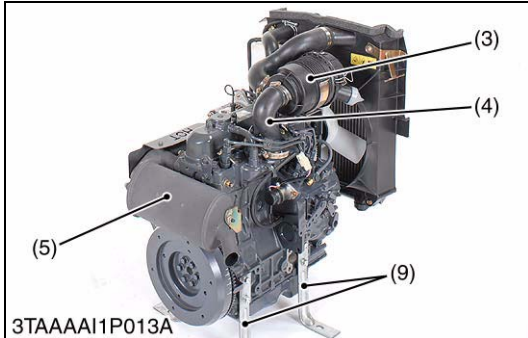
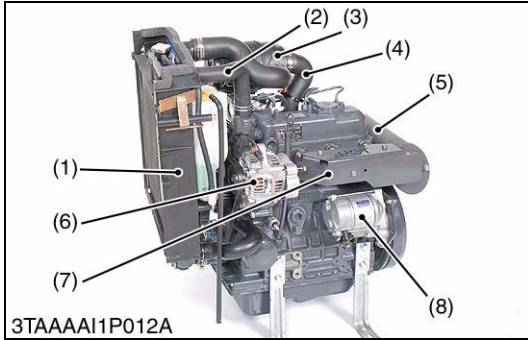

Draining Coolant, Radiator, Air Cleaner and Muffler etc.

CAUTION

- Never open the radiator cap while operating or immediately after stopping. Otherwise, hot water will spout out from the radiator. Wait for more than ten minutes to cool the radiator, before opening the cap

1. Set the engine stands (9) to the crankcase.
2. Open the radiator drain plug, and remove radiator cap to completely drain the coolant.
3. After all coolant is drained, close the drain plug.
4. Loosen the inlet hose band and the radiator hose bands, and remove the radiator (1) with the radiator hoses (2) and the air cleaner (3).
5. Loosen the fan belt. Remove the alternator (6), the starter motor (8), the fan and the fan belt.
6. Remove the heat proof cover (7), the muffler (5) and the exhaust manifold.

Coolant with recovery tank	Capacity	BX1860	2.5 L 2.6 U.S.qts 2.2 Imp.qts
		BX2360	2.7 L 2.8 U.S.qts 2.4 Imp.qts
		BX2660	3.3 L 3.5 U.S.qts 2.9 Imp.qts

- | | |
|-------------------|----------------------|
| (1) Radiator | (6) Alternator |
| (2) Radiator Hose | (7) Heat Proof Cover |
| (3) Air Cleaner | (8) Starter Motor |
| (4) Inlet Hose | (9) Engine Stand |
| (5) Muffler | |

W1051348

(3) Cylinder Head and Valves

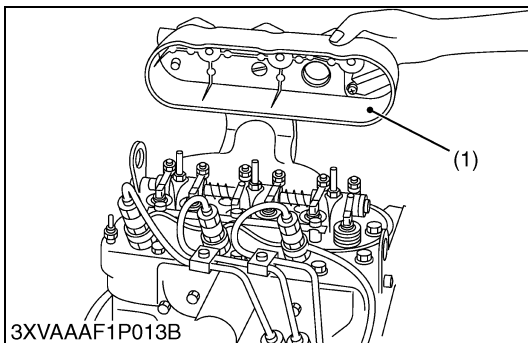

Cylinder Head Cover

1. Disconnect the breather hose.
2. Remove the cylinder head cover nuts.
3. Remove the cylinder head cover (1).

(When reassembling)

- Check to see if the cylinder head cover gasket is not defective.

[BX1860, BX2360]

Tightening torque	Cylinder head cover screw	9.81 to 11.2 N·m 1.00 to 1.15 kgf·m 7.24 to 8.31 lbf·ft
-------------------	---------------------------	---

[BX2660]

Tightening torque	Cylinder head cover screw	7 to 8 N·m 0.7 to 0.9 kgf·m 5 to 6 lbf·ft
-------------------	---------------------------	---

- (1) Cylinder Head Cover

W1028468

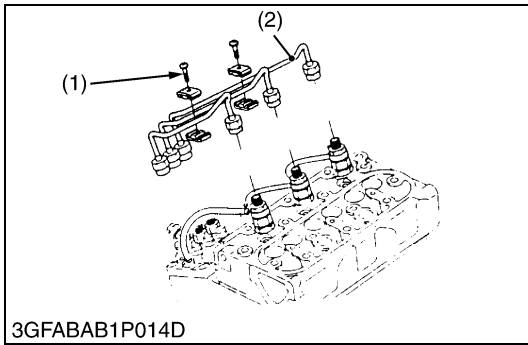

Injection Pipes

1. Loosen the screws to the pipe clamp (1).
2. Detach the injection pipes (2).

(When reassembling)

- Send compressed air into the pipes to blow out dust. Then, reassemble the pipes in the reverse order.

Tightening torque	Injection pipe retaining nut	25 to 34 N·m 2.5 to 3.5 kgf·m 18 to 25 lbf·ft
-------------------	------------------------------	---

(1) Pipe Clamp

(2) Injection Pipe

W1061858

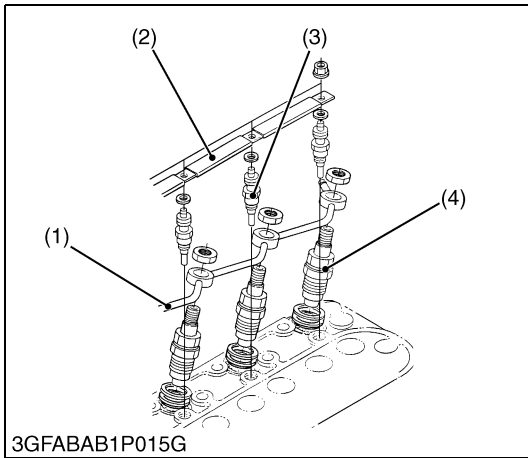

Nozzle Holder Assembly and Glow Plug

1. Remove the overflow pipe (1).
2. Remove the nozzle holder assemblies (4).
3. Remove the copper gasket (5) and heat seal (6).
4. Remove the lead (2) from the glow plugs (3).
5. Remove the glow plugs (3).

(When reassembling)

- Replace the copper gasket and heat seal with new one.

Tightening torque	Overflow pipe retaining nut	20 to 24 N·m 2.0 to 2.5 kgf·m 15 to 18 lbf·ft
	Nozzle holder assembly	49 to 68 N·m 5.0 to 7.0 kgf·m 37 to 50 lbf·ft
	Glow plug	7.9 to 14 N·m 0.80 to 1.5 kgf·m 5.8 to 10 lbf·ft

(1) Overflow Pipe

(4) Nozzle Holder Assembly

(2) Lead

(5) Copper Gasket

(3) Glow Plug

(6) Heat Seal

W1062243

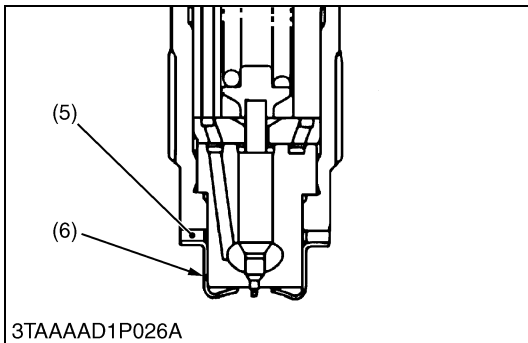

Nozzle Heat Seal Removal Procedure

■ IMPORTANT

- Use a plus (phillips head) screw driver (1) that has a diameter which is bigger than the heat seal hole (Approx. 6 mm (1/4 in.)).

1. Drive screw driver (1) lightly into the heat seal hole.
2. Turn screw driver three or four times each way.
3. While turning the screw driver, slowly pull the heat seal (4) out together with the injection nozzle gasket (3).
4. If the heat seal drops, repeat the above procedure.

(When reassembling)

- Heat seal and injection nozzle gasket must be changed when the injection nozzle is removed for cleaning or for service.

(1) Plus Screw Driver

(3) Injection Nozzle Gasket

(2) Injection Nozzle

(4) Heat Seal

W1062698

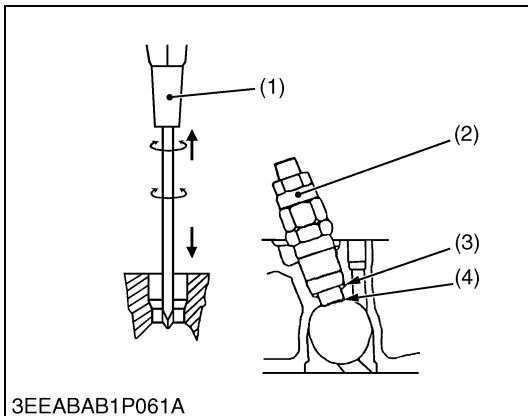

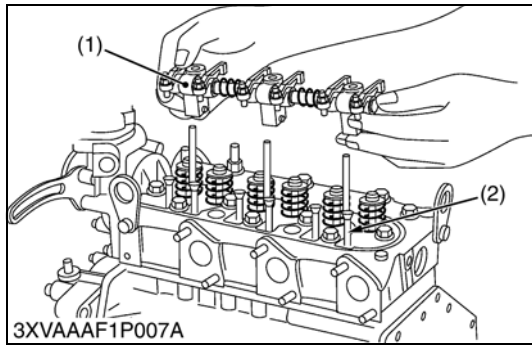

Rocker Arm and Push Rod

1. Remove the rocker arm bracket screw. [BX1860, BX2360]
Remove the rocker arm bracket nut. [BX2660]
2. Detach the rocker arm assembly (1).
3. Remove the push rods (2).

(When reassembling)

- When refitting the push rods (2) into the tappets (3), make sure the push rod locates correctly into the tappet seat.

■ IMPORTANT

- **After installing the rocker arm, be sure to adjust the valve clearance.**

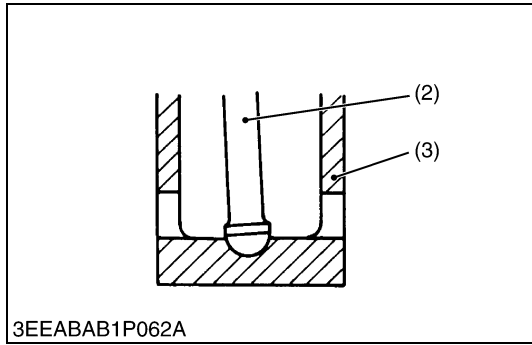

[BX1860, BX2360]

Tightening torque	Rocker arm bracket screw	9.81 to 11.2 N·m 1.00 to 1.15 kgf·m 7.24 to 8.31 lbf·ft
-------------------	--------------------------	---

[BX2660]

Tightening torque	Rocker arm bracket nut	22 to 26 N·m 2.2 to 2.7 kgf·m 16 to 19 lbf·ft
-------------------	------------------------	---

(1) Rocker Arm Assembly

(3) Tappet

(2) Push Rod

W1063063

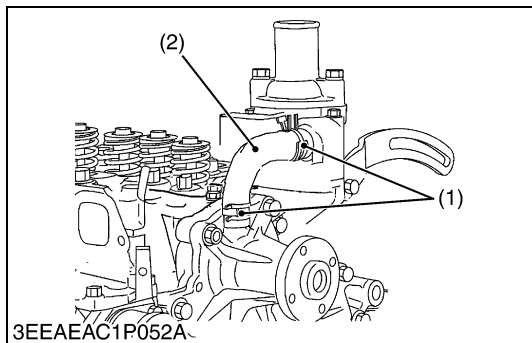

Cylinder Head and Cylinder Head Gasket

1. Loosen the pipe clamps (1), and remove the water return pipe (2).
2. Remove the cylinder head screw in the order of (n) to (a) and remove the cylinder head.
3. Remove the cylinder head gasket.

(When reassembling)

- Replace the cylinder head gasket with new one.
- When mounting the gasket, set it to the pin pipe holes. Take care not to mount it reversely.
- The cylinder head should be free of scratches and dust.
- Install the cylinder head, using care not to damage the gasket.
- After applying engine oil to the thread of screws, tighten them in several steps and specified sequence (a) to (n).

■ NOTE

- **Do not use O-ring on the pin pipe.**
- **It is not necessary to retighten the cylinder head screw and to readjust valve clearance after engine warmed up.**

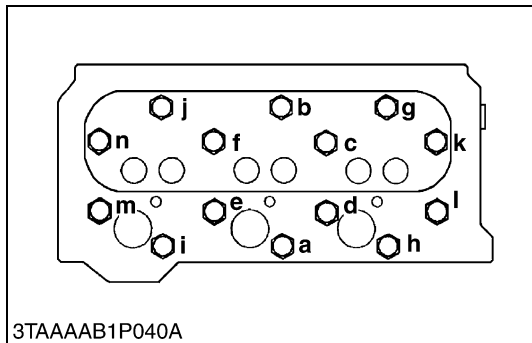

[BX1860, BX2360]

Tightening torque	Cylinder head screw	37.3 to 42.2 N·m 3.8 to 4.3 kgf·m 28 to 31 lbf·ft
-------------------	---------------------	---

[BX2660]

Tightening torque	Cylinder head screw	64 to 68 N·m 6.5 to 7.0 kgf·m 47 to 50 lbf·ft
-------------------	---------------------	---

(1) Clamp

n to a : To Loosen

(2) Return Pipe

a to n : To Tighten

(3) Pin Pipe

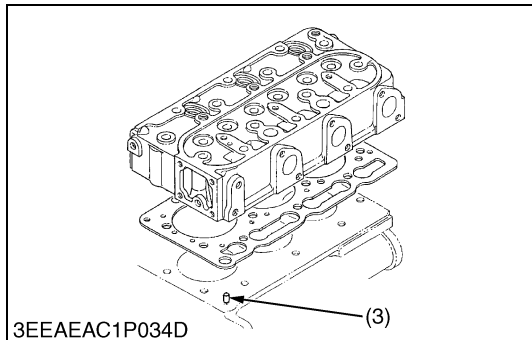

W10777620

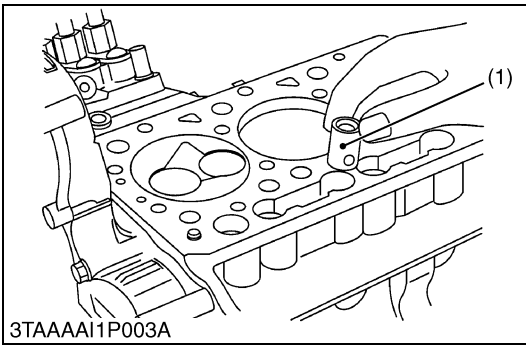

Tappets

1. Remove the tappets (1) from the crankcase.

(When reassembling)

- Visually check the contact between tappets and cams for proper rotation. If defect is found, replace tappets.
- Before installing the tappets, apply engine oil thinly around them.

■ **IMPORTANT**

- **Do not change the combination of tappet and tappet guide.**

(1) Tappet

W10781410

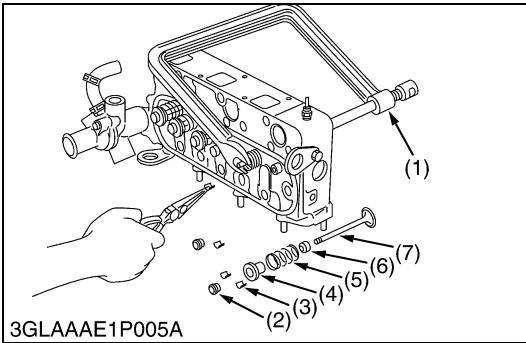

Valves

1. Remove the valve caps (2).
2. Remove the valve spring collet (3), pushing the valve spring retainer (4) by valve spring replacer (1).
3. Remove the valve spring retainer (4), valve spring (5) and valve stem seal (6).
4. Remove the valve (7).

(When reassembling)

- Wash the valve stem and valve guide hole, and apply engine oil sufficiently.
- After installing the valve spring collets, lightly tap the stem to assure proper fit with a plastic hammer.

■ **IMPORTANT**

- **Do not change the combination of valve and valve guide.**

(1) Valve Spring Replacer	(5) Valve Spring
(2) Valve Cap	(6) Valve Stem Seal
(3) Valve Spring Collet	(7) Valve
(4) Valve Spring Retainer	

W10783650

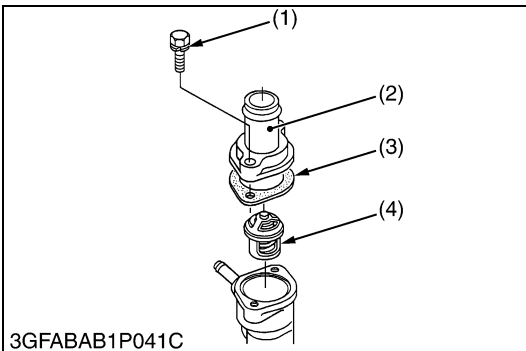

Thermostat Assembly

1. Remove the thermostat cover mounting screws (1), and remove the thermostat cover (2).
2. Remove the thermostat assembly (4).

(When reassembling)

- Apply a liquid gasket (Three Bond 1215 or equivalent) only at the thermostat cover side of the gasket (3).

(1) Thermostat Cover Mounting Screw	(3) Thermostat Cover Gasket
(2) Thermostat Cover	(4) Thermostat Assembly

W10786510

(4) Gear Case and Timing Gears

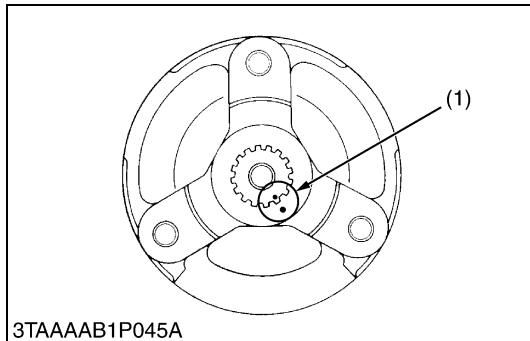
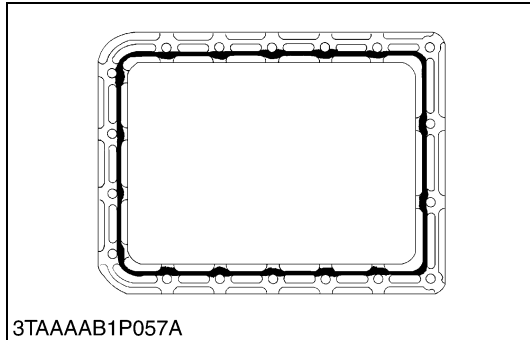
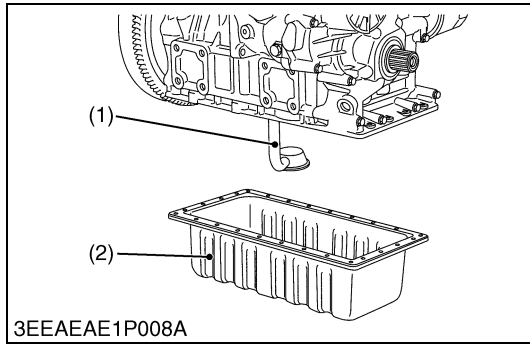

Oil Pan and Oil Strainer

1. Remove the oil pan mounting screws.
2. Remove the oil pan (2).
3. Remove the oil strainer (1).

(When reassembling)

- After cleaning the oil strainer, check to see that the filter mesh is clean, and install it.
- Visually check the O-ring, apply engine oil, and install it.
- Securely fit the O-ring to the oil strainer.
- To avoid uneven tightening, tighten oil pan mounting screws in diagonal order from the center.

■ IMPORTANT

- **Scrape off the old adhesive completely. Wipe the sealing surface clean using waste cloth soaked with gasoline. Now apply new adhesive 3.0 to 5.0 mm (0.12 to 0.19 in.) thick all over the contact surface. Apply the adhesive also on the center of the flange as well as on the inner wall of each screw hole.**
- **Cut the nozzle of the “liquid gasket” container at its second notch. Apply “liquid gasket” about 5.0 mm (0.19 in.) thick. Within 20 minutes after the application of fluid sealant, reassemble the components. Wait then for about 30 minutes, and pour oil in the crankcase.**

(1) Oil Strainer

(2) Oil Pan

W10788640

Fan Drive Pulley

1. Secure the flywheel to keep it from turning.
2. Remove the fan drive pulley screw.
3. Draw out the fan drive pulley with a puller.

(When reassembling)

- Install the pulley to crankshaft, aligning the mark (1) on them (3-cylinder engine).
- Apply engine oil to the fan drive pulley retaining screw. And tighten it.

[BX1860, BX2360]

Tightening torque	Fan drive pulley screw	118 to 127 N·m 12.0 to 13.0 kgf·m 86.8 to 94.0 lbf·ft
-------------------	------------------------	---

[BX2660]

Tightening torque	Fan drive pulley screw	236 to 245 N·m 24.0 to 25.0 kgf·m 174 to 180 lbf·ft
-------------------	------------------------	---

(1) Aligning Mark

W10791380

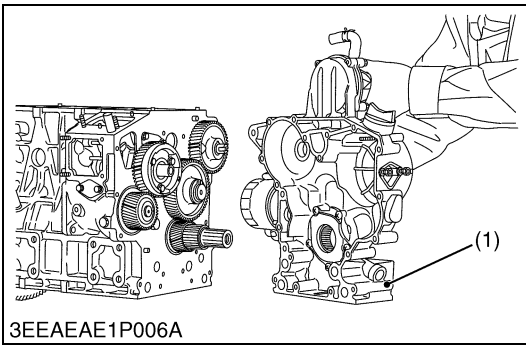

Gear Case

1. Remove the fuel feed pump.
2. Remove the gear case.

(When reassembling)

- Grease thinly to the oil seal, and install it, ensuring the lip does not come off.

(1) Gear Case

- a : Bolt Length = 45 mm (1.8 in.)
- b : Bolt Length = 50 mm (2.0 in.)
- c : Bolt Length = 55 mm (2.2 in.)
- d : Bolt Length = 65 mm (2.6 in.)
- e : Bolt Length = 68 mm (2.7 in.)
- f : Bolt Length = 70 mm (2.8 in.)
- g : Bolt Length = 85 mm (3.3 in.)
- h : Nut

W1079380

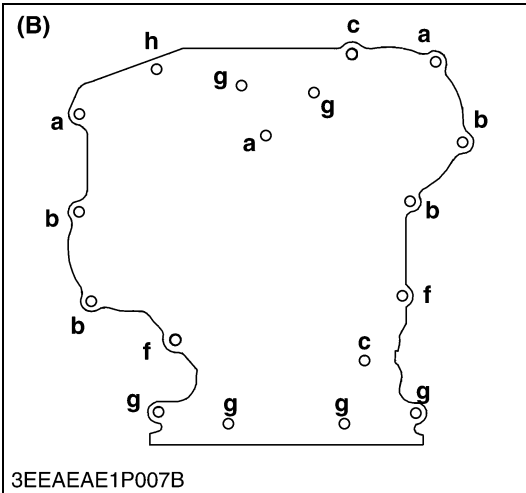

Speed Control Plate

1. Remove the engine stop solenoid.
2. Remove the speed control plate (1).

(When reassembling)

- Apply a liquid gasket (Three Bond 1215 or equivalent) to both sides of the solenoid cover gasket and control plate gasket.
- Be careful not to drop the governor spring (2) into the crankcase.

(1) Speed Control Plate

(2) Governor Spring

W1073180

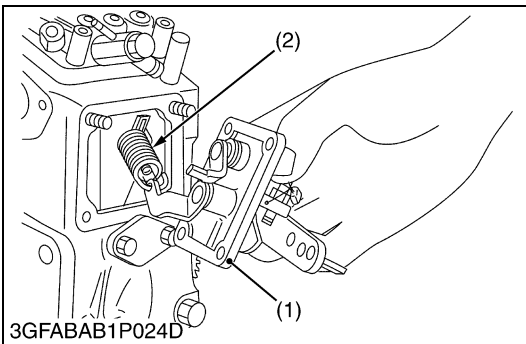

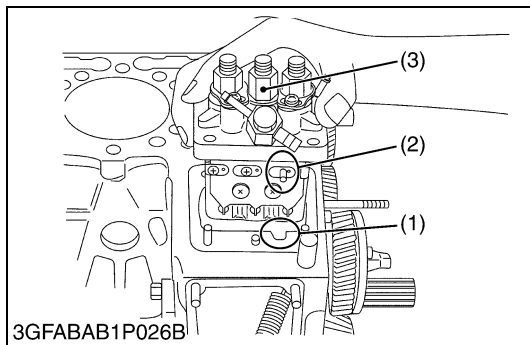

Injection Pump

1. Disconnect the start spring (4) on the thrust lever side (5).
2. Align the control rack pin (2) with the notch (1) on the crankcase, and remove the injection pump (3).
3. Remove the injection pump shims.
4. In principle, the injection pump should not be disassembled.

(When reassembling)

- When installing the injection pump, insert the control rack pin (2) firmly into the groove (7) of the thrust lever of fork lever.

■ NOTE

- **Addition or reduction of shim (0.05 mm, 0.002 in.) delays or advances the injection timing by approx. 0.0087 rad (0.50 °).**
- **In disassembling and replacing, be sure to use the same number or new gasket shims with the same thickness.**

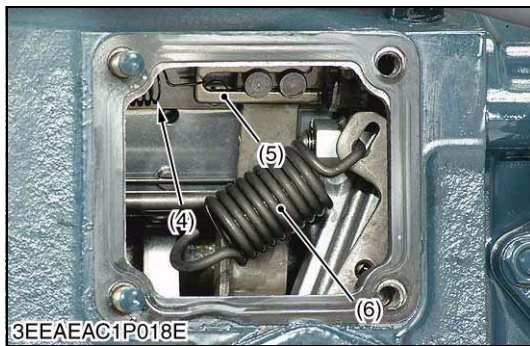

- | | |
|----------------------|---------------------|
| (1) Notch | (5) Thrust Lever |
| (2) Control Rack Pin | (6) Governor Spring |
| (3) Injection Pump | (7) Groove |
| (4) Start Spring | |

W1073414

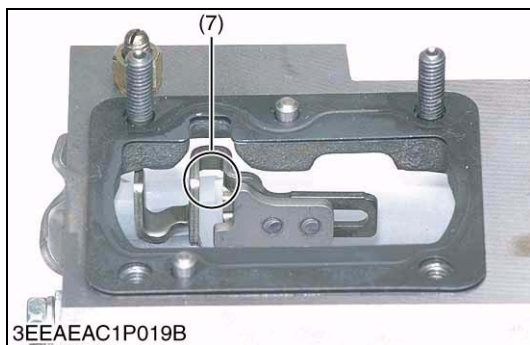

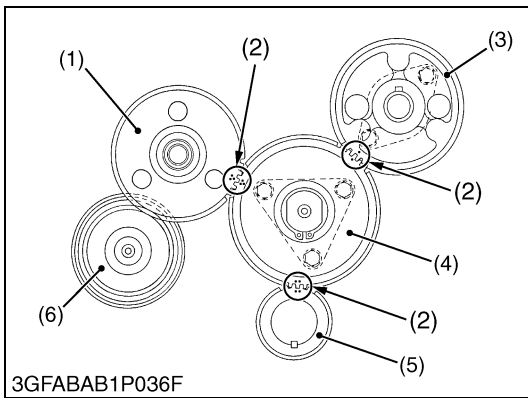

Cam Gear, Idle Gear 1, 2 and Governor Gear

1. Remove the idle gear 1 (4).
2. Remove the fuel camshaft stopper (7).
3. Draw out the fuel cam gear (1) with fuel camshaft (8).
4. Remove the camshaft stopper bolt.
5. Remove the cam gear (3) with camshaft.
6. Remove the external snap ring (10) from the governor shaft (11).
7. Remove the governor gear (6) with governor shaft (11).

■ **NOTE**

- **Three-lever type fork lever**

To remove the governor shaft, follow the procedures in 5, 6 above and never remove fork lever and the max torque limiter.

(When reassembling)

- Apply engine oil thinly to the fuel camshaft before installation.
- Make sure to assemble the external snap ring of the governor shaft.
- Check the governor shaft for smooth rotation.

■ **IMPORTANT**

- **When replacing the ball bearing of governor shaft, securely fit the ball bearing (9) to the crankcase, apply an adhesive (Three Bond 1324B or equivalent) to the set screw (12), and fasten the screw until its tapered part contacts the circumferential end of the ball bearing.**
- **When installing the idle gear, be sure to align the alignment marks (2) on each gears.**

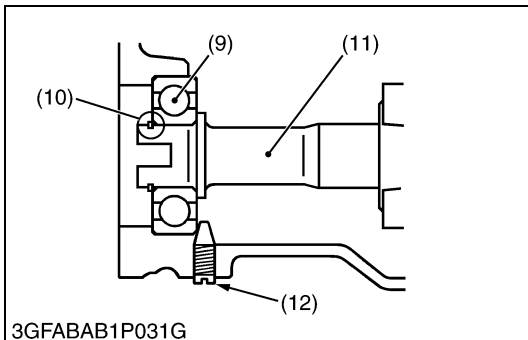
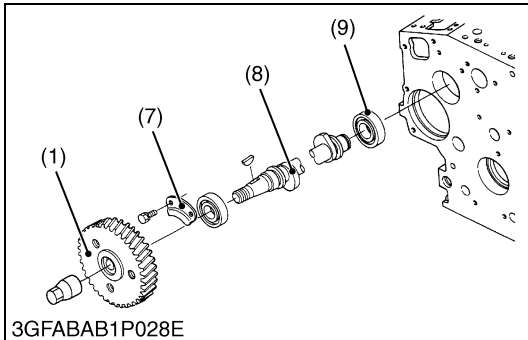

- | | |
|--------------------|---------------------------|
| (1) Fuel Cam Gear | (7) Fuel Camshaft Stopper |
| (2) Alignment Mark | (8) Fuel Camshaft |
| (3) Cam Gear | (9) Ball Bearing |
| (4) Idle Gear 1 | (10) External Snap Ring |
| (5) Crank Gear | (11) Governor Shaft |
| (6) Governor Gear | (12) Set Screw |

W1074222

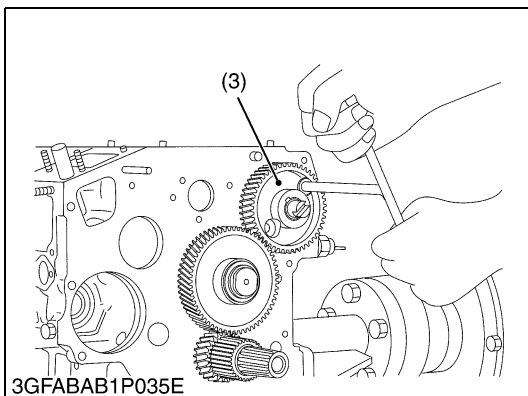

(5) Piston and Connecting Rod

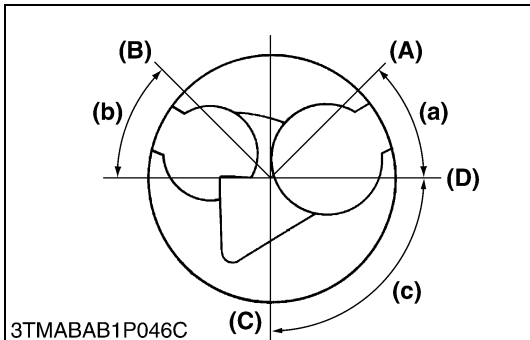
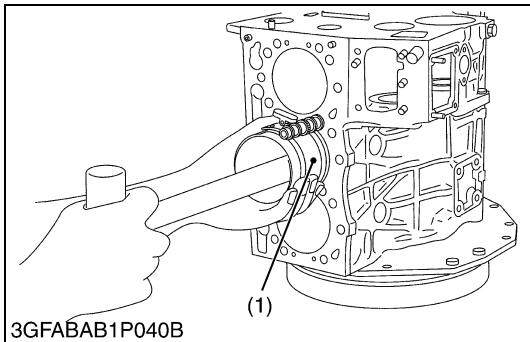
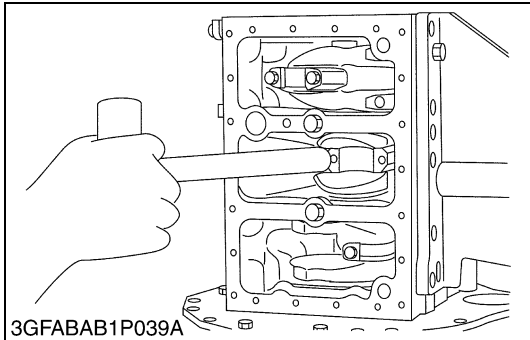
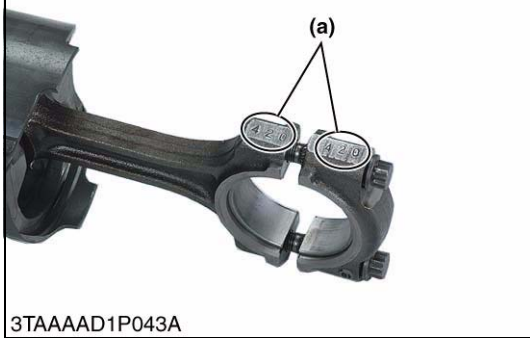
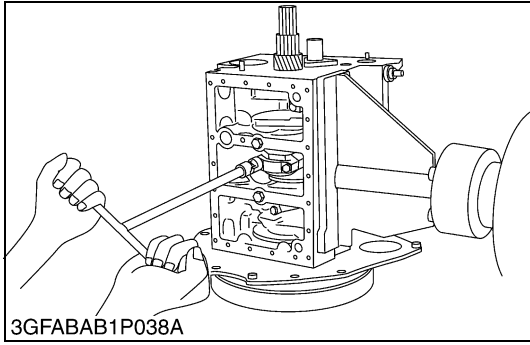

Connecting Rod

1. Remove the connecting rod cap.

(When reassembling)

- Align the marks (a) with each other. (Face the marks toward the injection pump.)
- Apply engine oil to the connecting rod screws and lightly screw it in by hand, then tighten it to the specified torque. If the connecting rod screw won't be screwed in smoothly, clean the threads. If the connecting rod screw is still hard to screw in, replace it.

[BX1860, BX2360]

Tightening torque	Connecting rod screw	27 to 30 N·m 2.7 to 3.1 kgf·m 20 to 22 lbf·ft
-------------------	----------------------	---

[BX2660]

Tightening torque	Connecting rod screw	42 to 46 N·m 4.2 to 4.7 kgf·m 31 to 33 lbf·ft
-------------------	----------------------	---

(a) Mark

W10801990

Pistons

1. Turn the flywheel and bring the piston to top dead center.
2. Draw out the piston upward by lightly tapping it from the bottom of the crankcase with the grip of a hammer.
3. Draw out the other piston in the same method as above.

(When reassembling)

- Before inserting the piston into the cylinder, apply enough engine oil to the piston.
- When inserting the piston into the cylinder, face the mark on the connecting rod to the injection pump.

■ IMPORTANT

- Do not change the combination of cylinder and piston. Make sure of the position of each piston by marking. For example, mark "1" on the No.1 piston.
- When installing the piston into the cylinder, place the gaps of all the piston rings as shown in the figure.
- Carefully insert the pistons using a piston ring compressor (1). Otherwise, their chrome-plated section may be scratched, causing trouble inside the cylinder.

(1) Piston Ring Compressor

- (A) Top Ring Gap
- (B) Second Ring Gap
- (C) Oil Ring Gap
- (D) Piston Pin Hole
- (a) 0.79 rad (45°)
- (b) 0.79 rad (45°)
- (c) 1.6 rad (90°)

W10803770

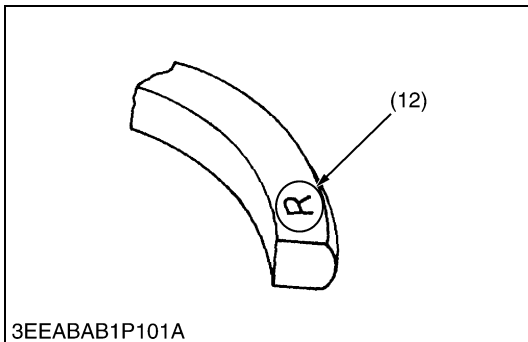
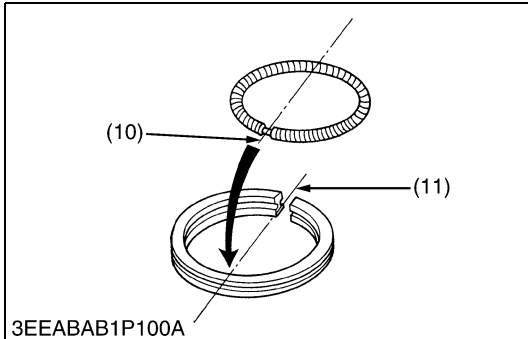
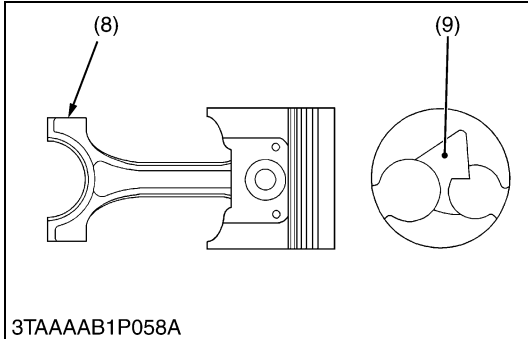
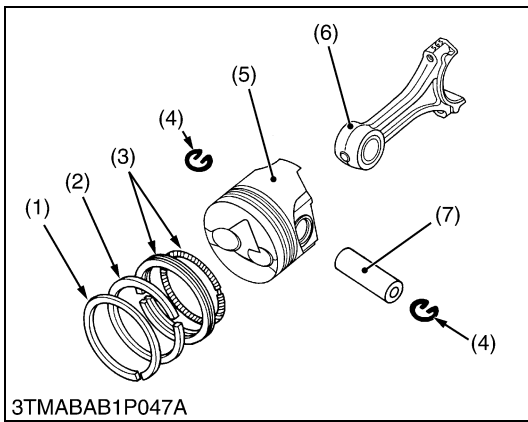

Piston Ring and Connecting Rod

1. Remove the piston rings using a piston ring tool.
2. Remove the piston pin (7), and separate the connecting rod (6) from the piston (5).

(When reassembling)

- Install the rings so that the manufacturer's mark (12) near the gap faces the top of the piston.
- When installing the oil ring onto the piston, place the expander joint (10) on the opposite side of the oil ring gap (11).
- Apply engine oil to the piston pin.
- When installing the connecting rod to the piston, immerse the piston in 80 °C (176 °F) oil for 10 to 15 minutes and insert the piston pin to the piston.
- When installing the connecting rod to the piston, align the mark (8) on the connecting rod to the fan-shaped concave (9).

NOTE

- **Mark the same number on the connecting rod and the piston so as not to change the combination.**

- | | |
|--------------------------|--------------------------|
| (1) Top Ring | (7) Piston Pin |
| (2) Second Ring | (8) Mark |
| (3) Oil Ring | (9) Fan-shaped Concave |
| (4) Piston Pin Snap Ring | (10) Expander Joint |
| (5) Piston | (11) Oil Ring Gap |
| (6) Connecting Rod | (12) Manufacturer's Mark |

W10811300

(6) Flywheel and Crankshaft

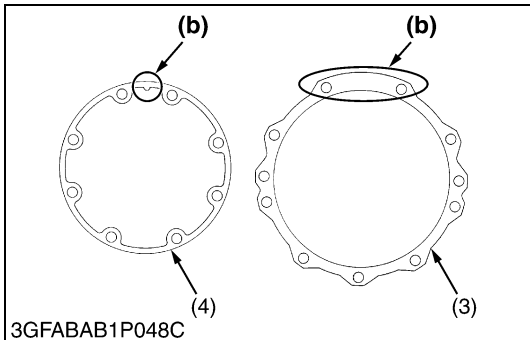
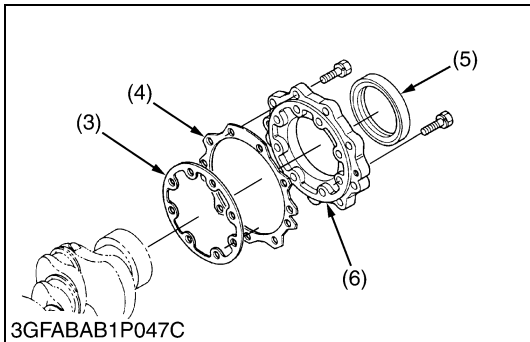
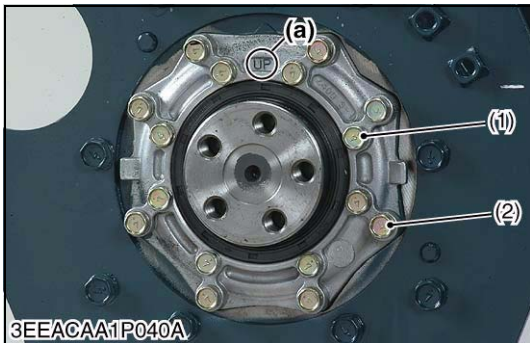
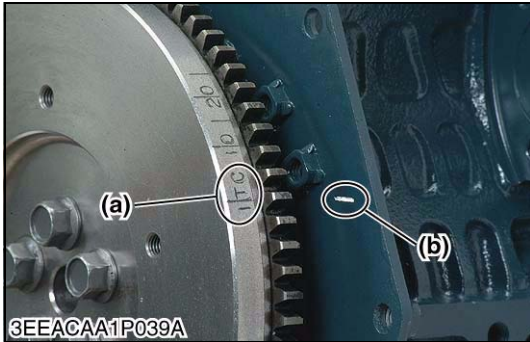
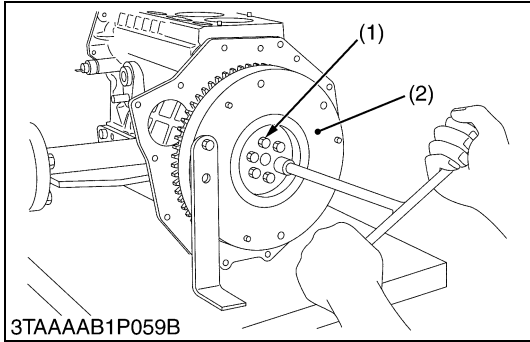

Flywheel

1. Secure the flywheel to keep it from turning, using a flywheel stopper.
2. Remove all flywheel screws (1) and then remove the flywheel (2).

(When reassembling)

- Align the “1TC” mark (a) on the outer surface of the flywheel horizontally with the alignment mark (b) on the rear end plate. Now fit the flywheel in position.
- Apply engine oil to the threads and the undercut surface of the flywheel screw and fit the screw.

Tightening torque	Flywheel screw	54 to 58 N·m 5.5 to 6.0 kgf·m 40 to 43 lbf·ft
-------------------	----------------	---

- (1) Flywheel Screw (a) 1TC Mark
(2) Flywheel (b) Alignment Mark

W10818970

Bearing Case Cover

1. Remove the bearing case cover mounting screws.
2. Remove the bearing case cover (6).

(When reassembling)

- Fit the bearing case gasket (3) and the bearing case cover gasket (4) with correct directions.
- Install the bearing case cover (6) to position the casting mark “UP” on it upward.
- Apply engine oil to the oil seal (5) lip and take care that it is not rolled when installing.
- Tighten the bearing case cover mounting screws with even force on the diagonal line.

Tightening torque	Bearing case cover mounting screw	9.81 to 11.2 N·m 1.00 to 1.15 kgf·m 7.24 to 8.31 lbf·ft
-------------------	-----------------------------------	---

- (1) Bearing Case Cover Mounting Screw (Inside) (5) Oil Seal
(2) Bearing Case Cover Mounting Screw (Outside) (6) Bearing Case Cover
(3) Bearing Case Gasket (a) Top Mark “UP”
(4) Bearing Case Cover Gasket (b) Upside

W10825950

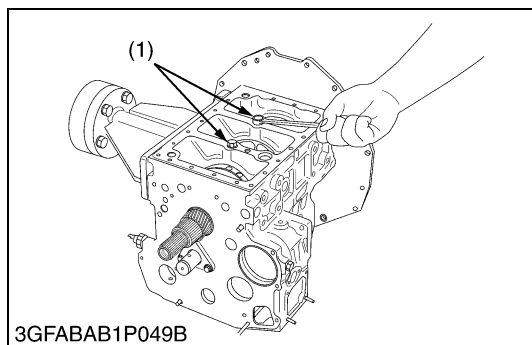

Crankshaft Assembly

1. Remove the main bearing case screw 2 (1).
2. Pull out the crankshaft assembly.

■ IMPORTANT

- Take care to protect crankshaft bearing 1 from scratches, caused by the crank gear, etc.. (Wrap the gear in vinyl tape, etc.)

(When reassembling)

- Clean the oil passage of the crankshaft with compressed air.
- Apply oil to the main bearing case screw 2 (1).
- Install the crankshaft assembly, aligning the screw hole of main bearing case with the screw hole of crankcase.
- Clean the oil passage of the crankshaft with compressed air.

[BX1860, BX2360]

Tightening torque	Main bearing case screw 2	27 to 30 N·m 2.7 to 3.1 kgf·m 20 to 22 lbf·ft
-------------------	---------------------------	---

[BX2660]

Tightening torque	Main bearing case screw 2	49 to 53 N·m 5.0 to 5.5 kgf·m 37 to 39 lbf·ft
-------------------	---------------------------	---

(1) Main Bearing Case Screw 2

W10833190

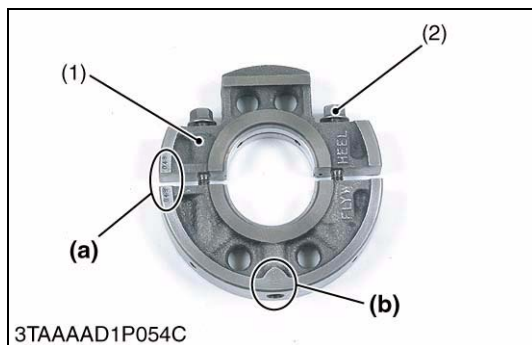

Main Bearing Case Assembly

1. Remove the two main bearing case screws 1 (2) of each main bearing cases.
2. Remove the main bearing case from crankshaft.

(When reassembling)

- Clean the oil passage in the main bearing cases.
- Apply clean engine oil on the bearings.
- Install the main bearing case assemblies in the original positions. Since diameters of main bearing cases vary, install them in order of markings (b) (A, B, C) from the gear case side.
- Match the alignment numbers (a) on the main bearing case assembly 1.
- When installing the main bearing case 1 and 2, face the mark "FLYWHEEL" to the flywheel.
- Install the thrust bearing (3) with its oil groove facing outward.
- Confirm that the main bearing case moves smoothly after tightening the main bearing case screw 1 to the specified torque.

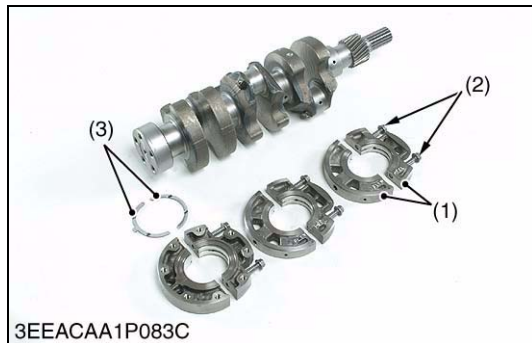

[BX1860, BX2360]

Tightening torque	Main bearing case screw 1	13 to 15 N·m 1.3 to 1.6 kgf·m 9.4 to 11 lbf·ft
-------------------	---------------------------	--

[BX2660]

Tightening torque	Main bearing case screw 1	30 to 34 N·m 3.0 to 3.5 kgf·m 22 to 25 lbf·ft
-------------------	---------------------------	---

(1) Main Bearing Case Assembly 1

(2) Main Bearing Case Screw 1

(3) Thrust Bearing

(a) Alignment Number

(b) Marking (A, B, C)

W1083973

[3] SERVICING

(1) Cylinder Head and Valves

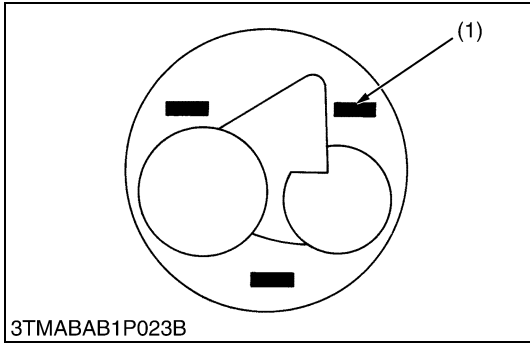

3TMABAB1P023B

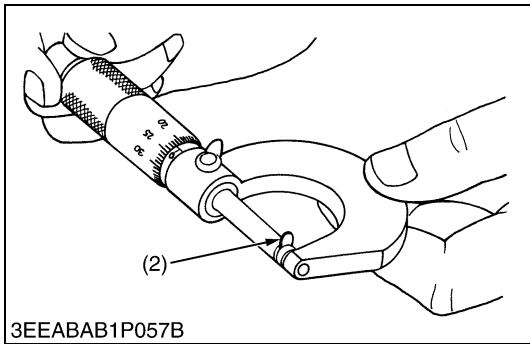

3EEABAB1P057B

Top Clearance

1. Remove the cylinder head. (Do not attempt to remove the cylinder head gasket.)
2. Move the piston up and stick a strip of fuse [1.5 mm dia. (0.059 in. dia.), 5 to 7 mm long (0.197 to 0.276 in. long)] on the piston head at three positions with grease so as to avoid the intake and exhaust valves and the combustion chamber ports.
3. Lower the piston, and install the cylinder head and tighten the cylinder head screws to the specified torque.
4. Turn the flywheel until the piston exceeds top dead center.
5. Remove the cylinder head, and measure the thickness of the squeezed fuses.
6. If the measurement is not within the factory specifications, check the oil clearance between the crankpin and crankpin bearing and between the piston pin and small end bushing.

■ NOTE

- After checking the top clearance, be sure to assemble the cylinder head with a new cylinder head gasket.

Top clearance	Factory spec.	0.55 to 0.70 mm 0.022 to 0.027 in.
---------------	---------------	---------------------------------------

[BX1860, BX2360]

Tightening torque	Cylinder head screw	38 to 42 N·m 3.8 to 4.3 kgf·m 28 to 31 lbf·ft
-------------------	---------------------	---

[BX2660]

Tightening torque	Cylinder head screw	64 to 68 N·m 6.5 to 7.0 kgf·m 47 to 50 lbf·ft
-------------------	---------------------	---

(1) Fuse

(2) Fuse

W1020190

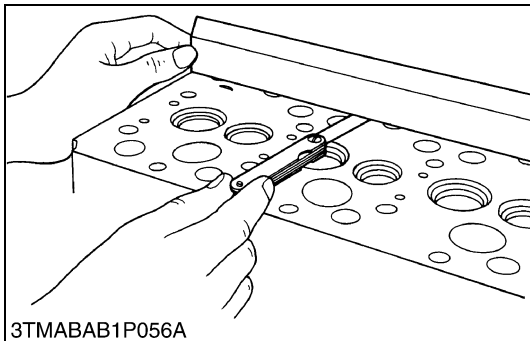

3TMABAB1P056A

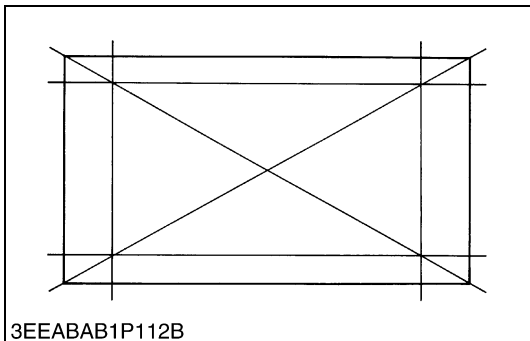

3EEABAB1P112B

Cylinder Head Surface Flatness

1. Clean the cylinder head surface.
2. Place a straightedge on the cylinder head's four sides and two diagonal as shown in the figure.
3. Measure the clearance with a thickness gauge.
4. If the measurement exceeds the allowable limit, correct it with a surface grinder.

■ IMPORTANT

- Do not place the straightedge on the combustion chamber.
- Be sure to check the valve recessing after correcting.

Cylinder head surface flatness	Allowable limit	0.05 mm 0.002 in.
--------------------------------	-----------------	----------------------

W1027737

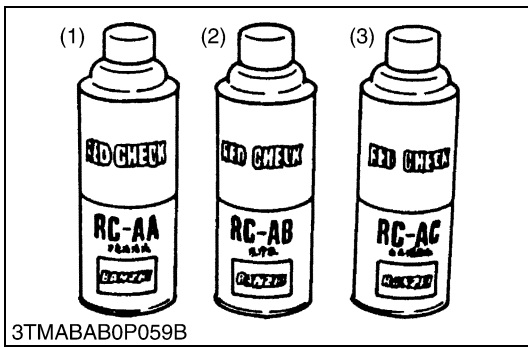

Cylinder Head Flaw

1. Prepare an air spray red check.
2. Clean the surface of the cylinder head with detergent (2).
3. Spray the cylinder head surface with the red permeative liquid (1). Leave it five to ten minutes after spraying.
4. Wash away the red permeative liquid on the cylinder head surface with the detergent (2).
5. Spray the cylinder head surface with white developer (3).
6. If flawed, it can be identified as red marks.

- (1) Red Permeative Liquid (3) White Developer
 (2) Detergent

W1076542

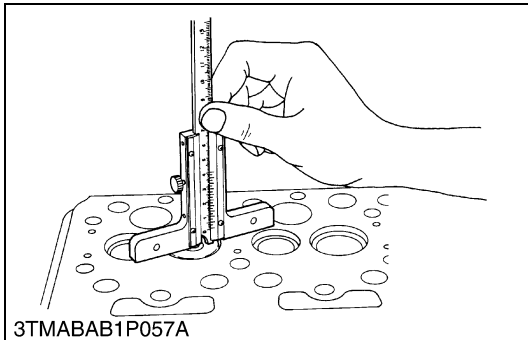

Valve Recessing

1. Clean the cylinder head surface, valve face and valve seat.
2. Insert the valve into the valve guide.
3. Measure the valve recessing with a depth gauge.
4. If the measurement exceeds the allowable limit, replace the valve.
5. If it still exceeds the allowable limit after replacing the valve, replace the cylinder head.

[BX1860, BX2360]

Valve recessing	Factory spec.	-0.10 (protrusion) to 0.10 (recessing) mm -0.0039 (protrusion) to 0.0039 (recessing) in.
	Allowable limit	0.30 (recessing) mm 0.012 (recessing) in.

[BX2660]

Valve recessing	Factory spec.	0.050 (protrusion) to 0.25 (recessing) mm 0.0020 (protrusion) to 0.0098 (recessing) in.
	Allowable limit	0.40 (recessing) mm 0.016 (recessing) in.

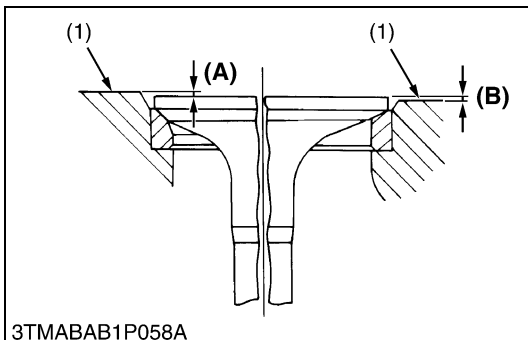

- (1) Cylinder Head Surface (A) Recessing
 (B) Protrusion

W10768800

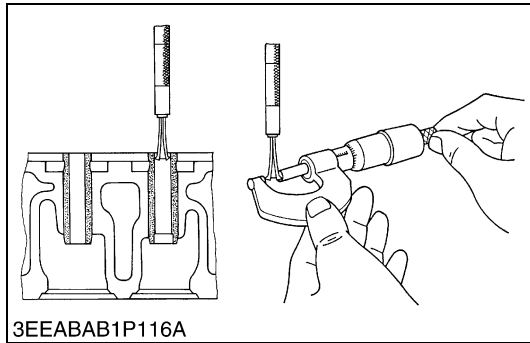
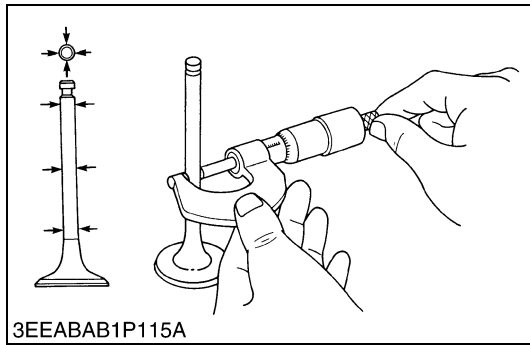

Clearance between Valve Stem and Valve Guide

1. Remove carbon from the valve guide section.
2. Measure the valve stem O.D. with an outside micrometer.
3. Measure the valve guide I.D. with a small hole gauge, and calculate the clearance.
4. If the clearance exceeds the allowable limit, replace the valves.
If it still exceeds the allowable limit, replace the valve guide.

[BX1860, BX2360]

Clearance between valve stem and valve guide	Factory spec.	0.030 to 0.057 mm 0.0012 to 0.0022 in.
	Allowable limit	0.10 mm 0.0039 in.
Valve stem O.D.	Factory spec.	5.968 to 5.980 mm 0.2350 to 0.2354 in.
Valve guide I.D.	Factory spec.	6.010 to 6.025 mm 0.2367 to 0.2372 in.

[BX2660]

Clearance between valve stem and valve guide	Factory spec.	0.035 to 0.065 mm 0.0014 to 0.0025 in.
	Allowable limit	0.10 mm 0.0039 in.
Valve stem O.D.	Factory spec.	6.960 to 6.975 mm 0.2741 to 0.2746 in.
Valve guide I.D.	Factory spec.	7.010 to 7.025 mm 0.2760 to 0.2765 in.

W10774950

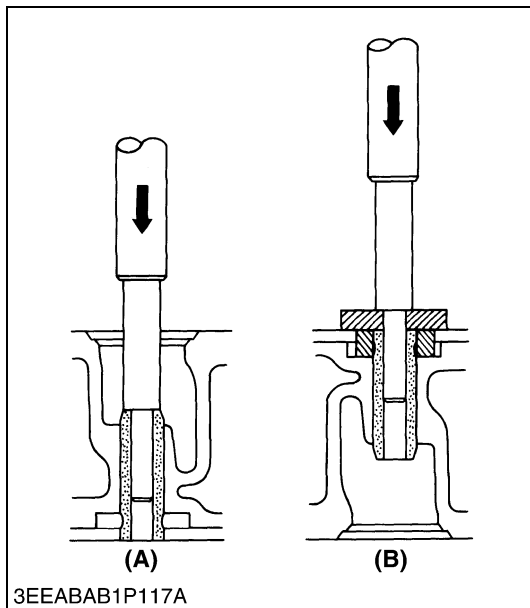

Replacing Valve Guide

(When removing)

1. Press out the used valve guide using a valve guide replacing tool.
(See page "SPECIAL TOOLS".)

(When installing)

1. Clean a new valve guide and valve guide bore, and apply engine oil to them.
2. Press in a new valve guide using a valve guide replacing tool.
3. Ream precisely the I.D. of the valve guide to the specified dimension.

[BX1860, BX2360]

Valve guide I.D. (Intake and exhaust)	Factory spec.	6.010 to 6.025 mm 0.2367 to 0.2372 in.
--	---------------	---

[BX2660]

Valve guide I.D. (Intake and exhaust)	Factory spec.	7.010 to 7.025 mm 0.2760 to 0.2765 in.
--	---------------	---

■ IMPORTANT

- Do not hit the valve guide with a hammer during replacement.

(A) When Removing

(B) When Installing

W10278890

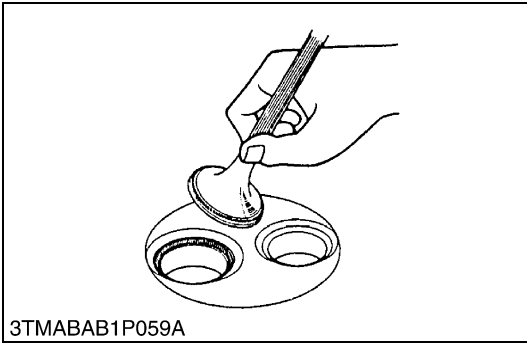

Valve Seating

1. Coat the valve face lightly with prussian blue and put the valve on its seat to check the contact.
2. If the valve does not seat all the way around the valve seat or the valve contact is less than 70 %, correct the valve seating as follows.
3. If the valve contact does not comply with the reference value, replace the valve or correct the contact of valve seating.

Valve seat width	Factory spec.	2.12 mm 0.0835 in.
------------------	---------------	-----------------------

- (1) Correct
(2) Incorrect

- (3) Incorrect

W10282190

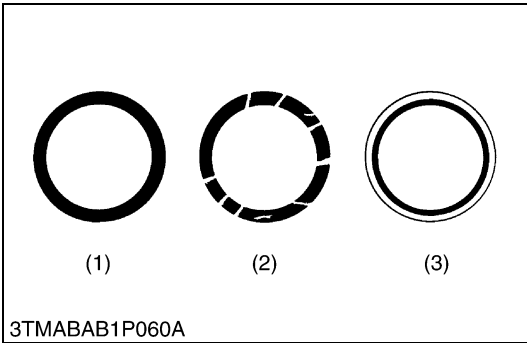

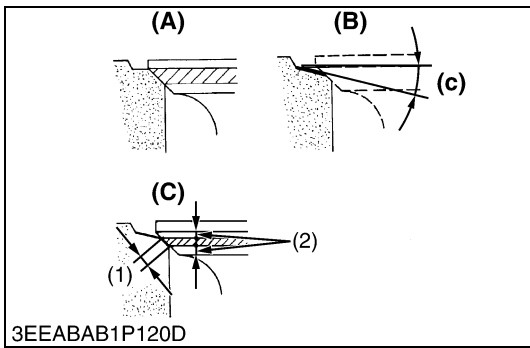
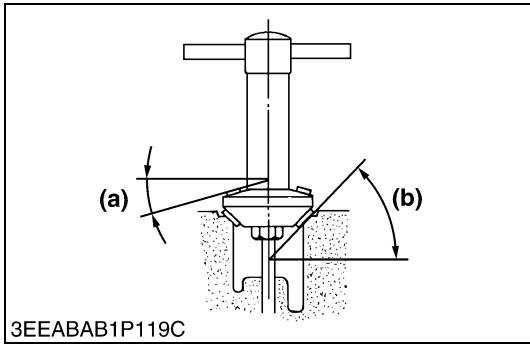
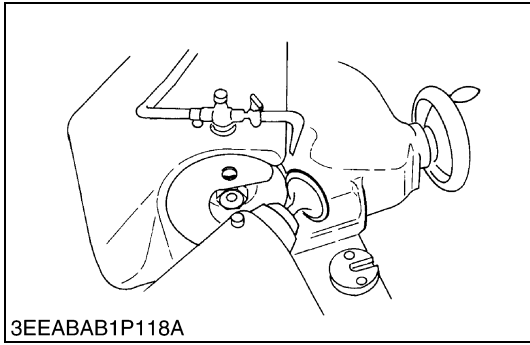

Correcting Valve and Valve Seat

NOTE

- Before correcting the valve and seat, check the valve stem and the I.D. of valve guide section, and repair them if necessary.
- After correcting the valve seat, be sure to check the valve recessing.

1) Correcting Valve

1. Correct the valve with a valve refacer.

[BX1860, BX2360]

Valve face angle	Factory spec.	0.79 rad 45 °
------------------	---------------	------------------

[BX2660]

Valve face angle	Factory spec.	IN.	1.0 rad 60 °
		EX.	0.79 rad 45 °

2) Correcting Valve Seat

1. Slightly correct the seat surface with a 1.0 rad (60 °) (intake valve) or 0.79 rad (45 °) (exhaust valve) valve seat cutter.
2. Resurface the seat surface with a 0.52 rad (30 °) valve seat cutter to intake valve seat and with a 0.26 rad (15 °) valve seat cutter to exhaust valve seat so that the width is close to specified valve seat width (2.12 mm, 0.0835 in.).
3. After resurfacing the seat, inspect for even valve seating, apply a thin film of compound between the valve face and valve seat, and fit them with valve lapping tool.
4. Check the valve seating with prussian blue. The valve seating surface should show good contact all the way around.

[BX1860, BX2360]

Valve seat angle	Factory spec.	0.79 rad 45 °
------------------	---------------	------------------

[BX2660]

Valve seat angle	Factory spec.	IN.	1.0 rad 60 °
		EX.	0.79 rad 45 °

- (1) Valve Seat Width
- (2) Identical Dimensions

- (A) Check Contact**
(B) Correct Seat Width
(C) Check Contact
(a) 0.26 rad (15 °) or 0.52 rad (30 °)
(b) 0.79 rad (45 °) or 1.0 rad (60 °)
(c) 0.52 rad (30 °) or 0.26 rad (15 °)

W10283500

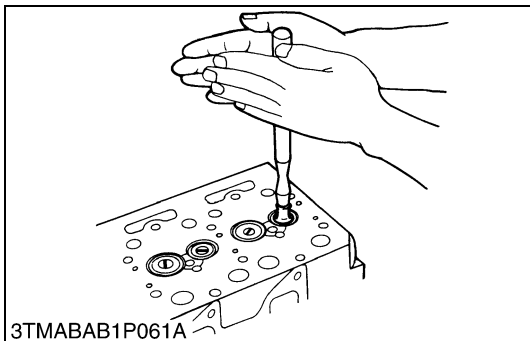

Valve Lapping

1. Apply compound evenly to the valve lapping surface.
2. Insert the valve into the valve guide. Lap the valve onto its seat with a valve flapper or screwdriver.
3. After lapping the valve, wash the compound away and apply oil, then repeat valve lapping with oil.
4. Apply prussian blue to the contact surface to check the seated rate. If it is less than 70 %, repeat valve lapping again.

IMPORTANT

- When valve lapping is performed, be sure to check the valve recessing and adjust the valve clearance after assembling the valve.

W10288140

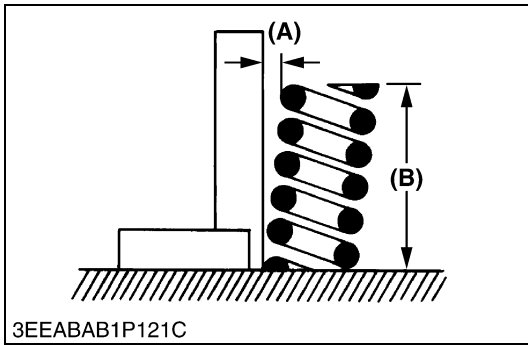

Free Length and Tilt of Valve Spring

1. Measure the free length **(B)** of valve spring with vernier calipers. If the measurement is less than the allowable limit, replace it.
2. Put the valve spring on a surface plate, place a square on the side of the valve spring.
3. Check to see if the entire side is in contact with the square. Rotate the valve spring and measure the maximum tilt **(A)**. If the measurement exceeds the allowable limit, replace it.
4. Check the entire surface of the valve spring for scratches. If there is any defect, replace it.

[BX1860, BX2360]

Tilt (A)	Allowable limit	1.2 mm 0.047 in.
Free length (B)	Factory spec.	31.3 to 31.8 mm 1.24 to 1.25 in.
	Allowable limit	28.4 mm 1.12 in.

[BX2660]

Tilt (A)	Allowable limit	1.0 mm 0.039 in.
Free length (B)	Factory spec.	37.0 to 37.5 mm 1.46 to 1.47 in.
	Allowable limit	36.5 mm 1.44 in.

(A) Tilt

(B) Free Length

W10289350

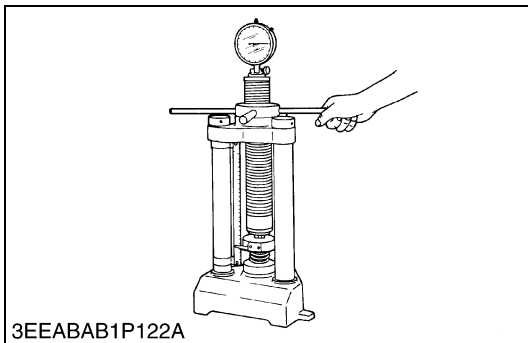

Valve Spring Setting Load

1. Place the valve spring on a tester and compress it to the same length it is actually compressed in the engine.
2. Read the compression load on the gauge.
3. If the measurement is less than the allowable limit, replace it.

[BX1860, BX2360]

Setting load / Setting length	Factory spec.	65 N / 27.0 mm 6.6 kgf / 27.0 mm 15 lbf / 1.06 in.
	Allowable limit	55 N / 27.0 mm 5.6 kgf / 27.0 mm 12 lbf / 1.06 in.

[BX2660]

Setting load / Setting length	Factory spec.	117.4 N / 31.0 mm 11.97 kgf / 31.0 mm 26.39 lbf / 1.22 in.
	Allowable limit	100.0 N / 31.0 mm 10.20 kgf / 31.0 mm 22.48 lbf / 1.22 in.

W10784360



Oil Clearance between Rocker Arm and Rocker Arm Shaft

1. Measure the rocker arm shaft O.D. with an outside micrometer.
2. Measure the rocker arm I.D. with an inside micrometer, and then calculate the oil clearance.
3. If the oil clearance exceeds the allowable limit, replace the rocker arm and measure the oil clearance again. If it still exceeds the allowable limit, replace also the rocker arm shaft.

[BX1860, BX2360]

Oil clearance between rocker arm and rocker arm shaft	Factory spec.	0.016 to 0.045 mm 0.00063 to 0.0017 in.
	Allowable limit	0.15 mm 0.0059 in.
Rocker arm shaft O.D.	Factory spec.	10.473 to 10.484 mm 0.41233 to 0.41275 in.
Rocker arm I.D.	Factory spec.	10.500 to 10.518 mm 0.41339 to 0.41409 in.

[BX2660]

Oil clearance between rocker arm and rocker arm shaft	Factory spec.	0.016 to 0.045 mm 0.00063 to 0.0017 in.
	Allowable limit	0.10 mm 0.0039 in.
Rocker arm shaft O.D.	Factory spec.	11.973 to 11.984 mm 0.47138 to 0.47181 in.
Rocker arm I.D.	Factory spec.	12.000 to 12.018 mm 0.47244 to 0.47314 in.

W10291500

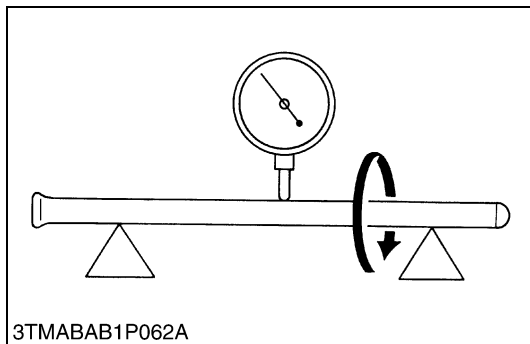

Push Rod Alignment

1. Place the push rod on V blocks.
2. Measure the push rod alignment.
3. If the measurement exceeds the allowable limit, replace the push rod.

Push rod alignment	Allowable limit	0.25 mm 0.0098 in.
--------------------	-----------------	-----------------------

W10292900

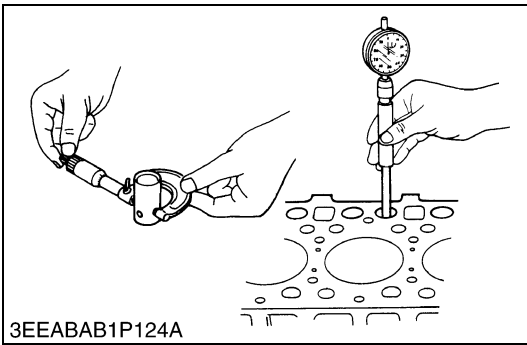

Oil Clearance between Tappet and Tappet Guide Bore

1. Measure the tappet O.D. with an outside micrometer.
2. Measure the I.D. of the tappet guide bore with a cylinder gauge, and calculate the oil clearance.
3. If the oil clearance exceeds the allowable limit or the tappet is damaged, replace the tappet.

[BX1860, BX2360]

Oil Clearance between tappet and tappet guide bore	Factory spec.	0.016 to 0.052 mm 0.00063 to 0.0020 in.
	Allowable limit	0.10 mm 0.0039 in.
Tappet O.D.	Factory spec.	17.966 to 17.984 mm 0.70733 to 0.70803 in.
Tappet guide bore I.D.	Factory spec.	18.000 to 18.018 mm 0.70867 to 0.70937 in.

[BX2660]

Oil Clearance between tappet and tappet guide bore	Factory spec.	0.020 to 0.062 mm 0.00079 to 0.0024 in.
	Allowable limit	0.07 mm 0.003 in.
Tappet O.D.	Factory spec.	19.959 to 19.980 mm 0.78579 to 0.78661 in.
Tappet guide bore I.D.	Factory spec.	20.000 to 20.021 mm 0.78740 to 0.78822 in.

W1051412

(2) Timing Gears, Camshaft and Governor Gear

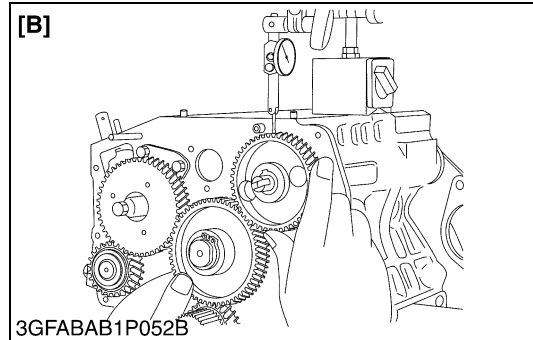
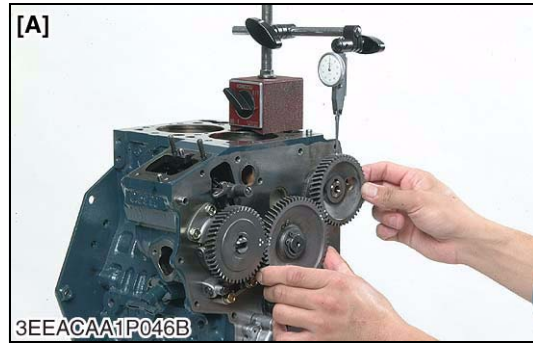

Timing Gear Backlash

1. Set a dial indicator (lever type) with its tip on the gear tooth.
2. Move the gear to measure the backlash, holding its mating gear.
3. If the backlash exceeds the allowable limit, check the oil clearance of the shafts and the gear.
4. If the oil clearance is proper, replace the gear.

[BX1860, BX2360]

Backlash between idle gear and crank gear	Factory spec.	0.0430 to 0.124 mm 0.00170 to 0.00488 in.
	Allowable limit	0.15 mm 0.0059 in.
Backlash between idle gear and cam gear	Factory spec.	0.0470 to 0.123 mm 0.00185 to 0.00484 in.
	Allowable limit	0.15 mm 0.0059 in.
Backlash between idle gear and injection pump gear	Factory spec.	0.0460 to 0.124 mm 0.00182 to 0.00488 in.
	Allowable limit	0.15 mm 0.0059 in.
Backlash between oil pump drive gear and crank gear	Factory spec.	0.0410 to 0.123 mm 0.00162 to 0.00484 in.
	Allowable limit	0.15 mm 0.0059 in.

[BX2660]

Backlash between idle gear 1 and crank gear	Factory spec.	0.0320 to 0.115 mm 0.00126 to 0.00452 in.
	Allowable limit	0.15 mm 0.0059 in.
Backlash between idle gear 1 and cam gear	Factory spec.	0.0360 to 0.114 mm 0.00142 to 0.00448 in.
	Allowable limit	0.15 mm 0.0059 in.
Backlash between idle gear 1 and injection pump gear	Factory spec.	0.0340 to 0.116 mm 0.00134 to 0.00456 in.
	Allowable limit	0.15 mm 0.0059 in.

[A] BX1860, BX2360

[B] BX2660

W10280630

Governor Gear Backlash (BX2660 only)

Backlash between injection pump gear and governor gear	Factory spec.	0.0300 to 0.117 mm 0.00119 to 0.00460 in.
	Allowable limit	0.15 mm 0.0059 in.

W1041576

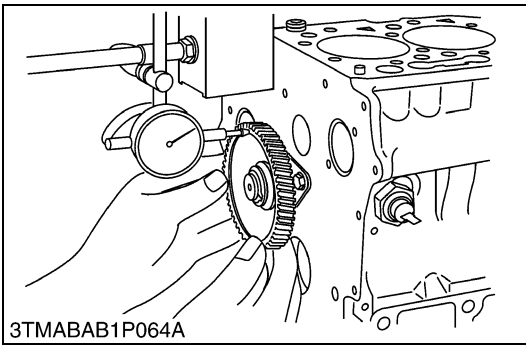

Idle Gear 1 Side Clearance

1. Set a dial indicator with its tip on the idle gear.
2. Measure the side clearance by moving the idle gear to the front and rear.
3. If the measurement exceeds the allowable limit, replace the idle gear collar.

Idle gear 1 side clearance	Factory spec.	0.20 to 0.51 mm 0.0079 to 0.020 in.
	Allowable limit	0.80 mm 0.031 in.

W10285590

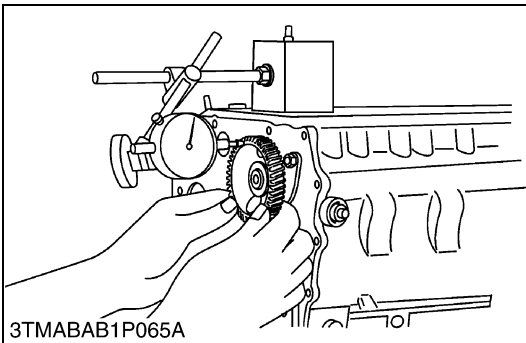

Camshaft Side Clearance

1. Set a dial indicator with its tip on the camshaft.
2. Measure the side clearance by moving the cam gear to the front to rear.
3. If the measurement exceeds the allowable limit, replace the camshaft stopper.

[BX1860, BX2360]

Camshaft side clearance	Factory spec.	0.15 to 0.31 mm 0.0059 to 0.012 in.
	Allowable limit	0.50 mm 0.020 in.

[BX2660]

Camshaft side clearance	Factory spec.	0.070 to 0.22 mm 0.0028 to 0.0086 in.
	Allowable limit	0.30 mm 0.012 in.

W10295630

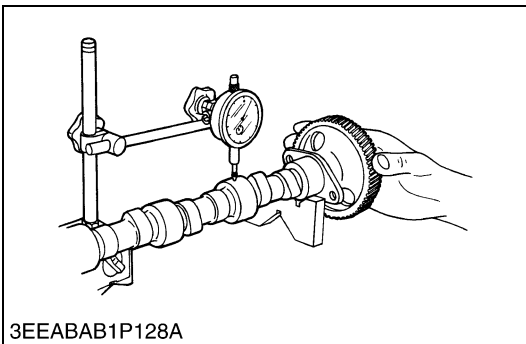

Camshaft Alignment

1. Support the camshaft with V blocks on the surface plate at both end journals.
2. Set a dial indicator with its tip on the intermediate journal.
3. Measure the camshaft alignment.
4. If the measurement exceeds the allowable limit, replace the camshaft.

Camshaft alignment	Allowable limit	0.01 mm 0.0004 in.
--------------------	-----------------	-----------------------

W10296710

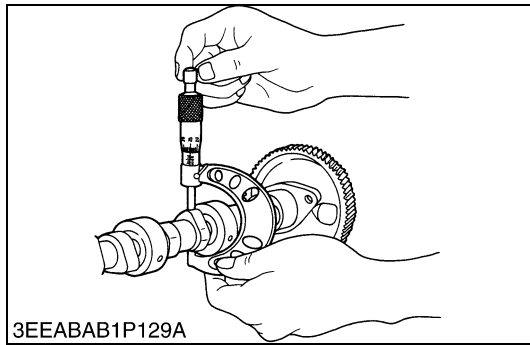

Cam Height

1. Measure the height of the cam at its highest point with an outside micrometer.
2. If the measurement is less than the allowable limit, replace the camshaft.

[BX1860, BX2360]

Cam height of intake and exhaust	Factory spec.	26.88 mm 1.058 in.
	Allowable limit	26.83 mm 1.056 in.

[BX2660]

Cam height of intake	Factory spec.	28.80 mm 1.134 in.
	Allowable limit	28.75 mm 1.132 in.
Cam height of exhaust	Factory spec.	29.00 mm 1.142 in.
	Allowable limit	28.95 mm 1.140 in.

W10297880

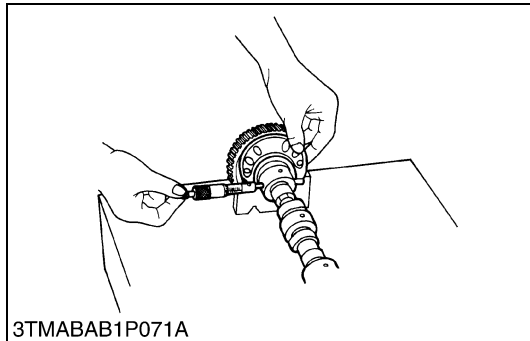

Oil Clearance of Camshaft Journal

1. Measure the camshaft journal O.D. with an outside micrometer.
2. Measure the cylinder block bore I.D. for camshaft with a cylinder gauge, and calculate the oil clearance.
3. If the oil clearance exceeds the allowable limit, replace the camshaft.

[BX1860, BX2360]

Oil clearance of camshaft journal	Factory spec.	0.050 to 0.091 mm 0.0020 to 0.0035 in.
	Allowable limit	0.15 mm 0.0059 in.
Camshaft journal O.D.	Factory spec.	32.934 to 32.950 mm 1.2967 to 1.2972 in.
Camshaft bearing I.D. (Cylinder block bore I.D.)	Factory spec.	33.000 to 33.025 mm 1.2993 to 1.3001 in.

[BX2660]

Oil clearance of camshaft journal	Factory spec.	0.050 to 0.091 mm 0.0020 to 0.0035 in.
	Allowable limit	0.15 mm 0.0059 in.
Camshaft journal O.D.	Factory spec.	35.934 to 35.950 mm 1.4147 to 1.4153 in.
Camshaft bearing I.D. (Cylinder block bore I.D.)	Factory spec.	36.000 to 36.025 mm 1.4173 to 1.4183 in.

W10299330

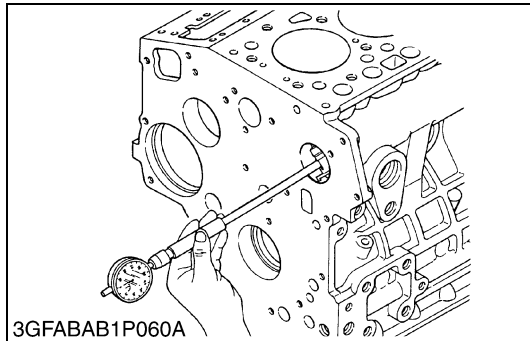

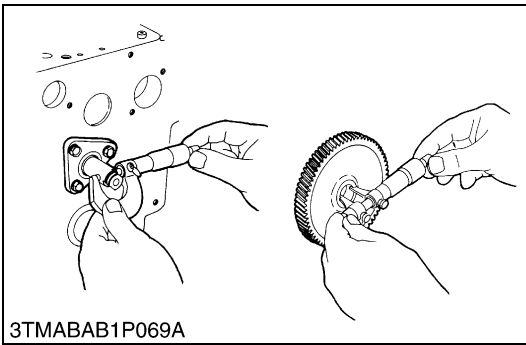

Oil Clearance between Idle Gear 1 Shaft and Idle Gear Bushing

1. Measure the idle gear shaft O.D. with an outside micrometer.
2. Measure the idle gear bushing I.D. with an inside micrometer, and calculate the oil clearance.
3. If the oil clearance exceeds the allowable limit, replace the bushing.

If it still exceeds the allowable limit, replace the idle gear shaft.

[BX1860, BX2360]

Oil clearance between idle gear shaft 1 and idle gear bushing	Factory spec.	0.020 to 0.084 mm 0.00079 to 0.0033 in.
	Allowable limit	0.10 mm 0.0039 in.
Idle gear shaft 1 O.D.	Factory spec.	19.967 to 19.980 mm 0.78611 to 0.78661 in.
Idle gear bushing 1 I.D.	Factory spec.	20.000 to 20.051 mm 0.78741 to 0.78940 in.

[BX2660]

Oil clearance between idle gear shaft 1 and idle gear bushing	Factory spec.	0.020 to 0.054 mm 0.00079 to 0.0021 in.
	Allowable limit	0.10 mm 0.0039 in.
Idle gear shaft 1 O.D.	Factory spec.	25.967 to 25.980 mm 1.0223 to 1.0228 in.
Idle gear bushing 1 I.D.	Factory spec.	26.000 to 26.021 mm 1.0237 to 1.0244 in.

W10301050

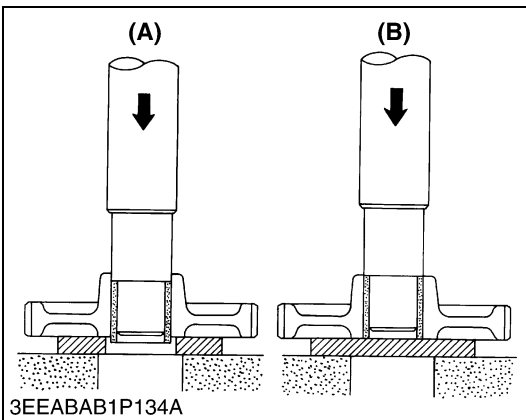

Replacing Idle Gear Bushing

(When removing)

1. Press out the used idle gear bushing using an idle gear bushing replacing tool. (See page "SPECIAL TOOLS".)

(When installing)

1. Clean a new idle gear bushing and idle gear bore, and apply engine oil to them.
2. Press in a new bushing using an idle gear bushing replacing tool, until it is flush with the end of the idle gear.

(A) When Removing

(B) When Installing

W10302410

(3) Piston and Connecting Rod

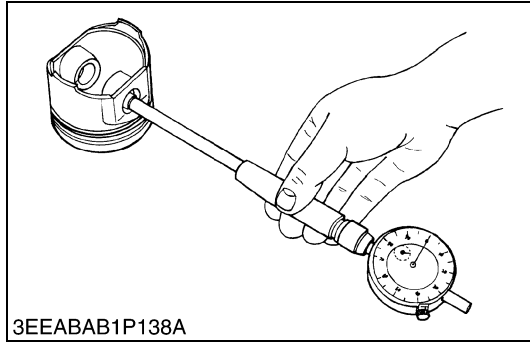

Piston Pin Bore I.D.

1. Measure the piston pin bore I.D. in both the horizontal and vertical directions with a cylinder gauge.
2. If the measurement exceeds the allowable limit, replace the piston.

[BX1860, BX2360]

Piston pin bore I.D.	Factory spec.	20.000 to 20.013 mm 0.78741 to 0.78791 in.
	Allowable limit	20.05 mm 0.7894 in.

[BX2660]

Piston pin bore I.D.	Factory spec.	22.000 to 22.013 mm 0.86615 to 0.86665 in.
	Allowable limit	22.03 mm 0.8673 in.

W10304770

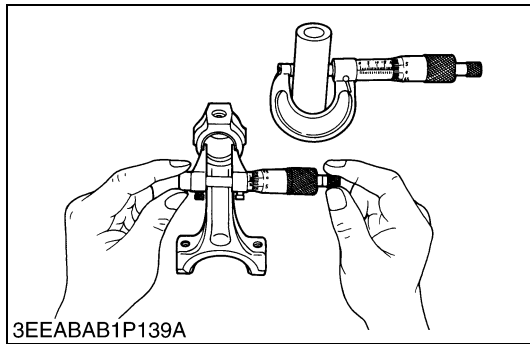

Oil Clearance between Piston Pin and Small End Bushing

1. Measure the piston pin O.D. where it contacts the bushing with an outside micrometer.
2. Measure the small end bushing I.D. with an inside micrometer, and calculate the oil clearance.
3. If the oil clearance exceeds the allowable limit, replace the bushing. If it still exceeds the allowable limit, replace the piston pin.

[BX1860, BX2360]

Oil clearance between piston pin and small end bushing	Factory spec.	0.015 to 0.075 mm 0.00059 to 0.0029 in.
	Allowable limit	0.15 mm 0.0059 in.
Piston pin O.D.	Factory spec.	20.002 to 20.011 mm 0.78748 to 0.78783 in.
Small end bushing I.D.	Factory spec.	20.025 to 20.040 mm 0.78839 to 0.78897 in.

[BX2660]

Oil clearance between piston pin and small end bushing	Factory spec.	0.014 to 0.038 mm 0.00056 to 0.0014 in.
	Allowable limit	0.15 mm 0.0059 in.
Piston pin O.D.	Factory spec.	22.002 to 22.011 mm 0.86622 to 0.86657 in.
Small end bushing I.D.	Factory spec.	22.025 to 22.040 mm 0.86713 to 0.86771 in.

W10305740

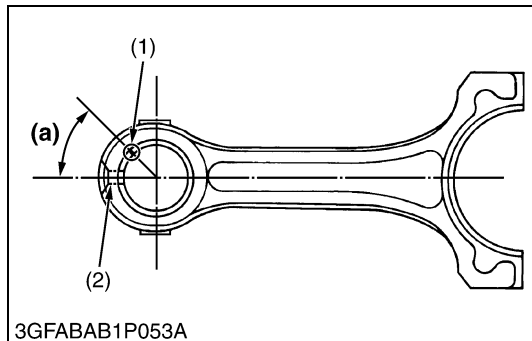
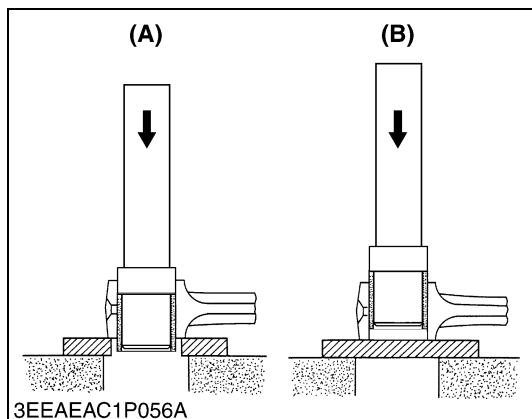

Replacing Small End Bushing

(When removing)

1. Press out the used bushing using a small end bushing replacing tool. (See page “SPECIAL TOOLS”.)

(When installing)

1. Clean a new small end bushing and bore, and apply engine oil to them.
2. Using a small end bushing replacing tool, press in a new bushing (service parts) taking due care to see that the connecting rod oil hole matches the bushing hole.

[BX1860, BX2360]

Oil clearance between piston pin and small end bushing (Spare parts)	Factory spec.	0.015 to 0.075 mm 0.00059 to 0.0029 in.
	Allowable limit	0.15 mm 0.0059 in.
Small end bushing I.D. (Spare parts)	Factory spec.	20.026 to 20.077 mm 0.78843 to 0.79043 in.

[BX2660]

Oil clearance between piston pin and small end bushing (Spare parts)	Factory spec.	0.015 to 0.038 mm 0.00056 to 0.0014 in.
	Allowable limit	0.15 mm 0.0059 in.
Small end bushing I.D. (Spare parts)	Factory spec.	22.025 to 22.040 mm 0.86713 to 0.86771 in.

- (1) Seam
- (2) Oil Hole

- (A) When Removing
- (B) When Installing
- (a) 0.79 rad (45 °)

W10307120

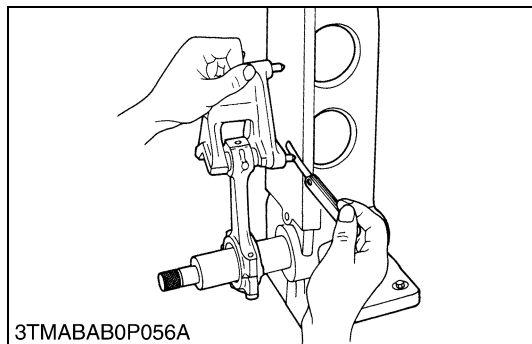

Connecting Rod Alignment

NOTE

- Since the I.D. of the connecting rod small end bushing is the basis of this check, check bushing for wear beforehand.

1. Install the piston pin into the connecting rod.
2. Install the connecting rod on the connecting rod alignment tool.
3. Put a gauge over the piston pin, and move it against the face plate.
4. If the gauge does not fit squarely against the face plate, measure the space between the pin of the gauge and the face plate.
5. If the measurement exceeds the allowable limit, replace the connecting rod.

Connecting rod alignment	Allowable limit	0.05 mm 0.002 in.
--------------------------	-----------------	----------------------

W10314620

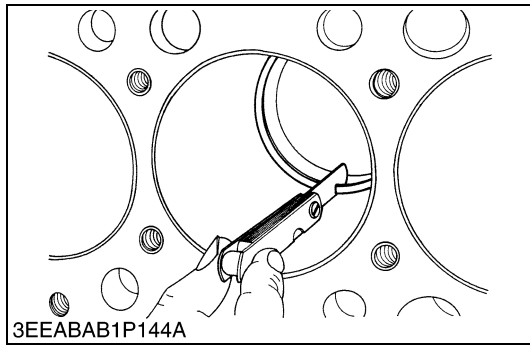

Piston Ring Gap

1. Insert the piston ring into the lower part of the cylinder (the least worn out part) with a piston.
2. Measure the ring gap with a thickness gauge.
3. If the measurement exceeds the allowable limit, replace the piston ring.

[BX1860]

Piston ring gap	Top ring	Factory spec.	0.15 to 0.30 mm 0.0059 to 0.011 in.
		Allowable limit	1.20 mm 0.0472 in.
	Second ring	Factory spec.	0.30 to 0.45 mm 0.012 to 0.017 in.
		Allowable limit	1.20 mm 0.0472 in.
	Oil ring	Factory spec.	0.15 to 0.30 mm 0.0059 to 0.011 in.
		Allowable limit	1.20 mm 0.0472 in.

[BX2360]

Piston ring gap	Top ring	Factory spec.	0.20 to 0.35 mm 0.0079 to 0.013 in.
		Allowable limit	1.25 mm 0.0492 in.
	Second ring	Factory spec.	0.35 to 0.50 mm 0.014 to 0.019 in.
		Allowable limit	1.25 mm 0.0492 in.
	Oil ring	Factory spec.	0.20 to 0.35 mm 0.0079 to 0.013 in.
		Allowable limit	1.25 mm 0.0492 in.

[BX2660]

Piston ring gap	Top ring	Factory spec.	0.30 to 0.45 mm 0.012 to 0.017 in.
		Allowable limit	1.25 mm 0.0492 in.
	Second ring	Factory spec.	0.30 to 0.45 mm 0.012 to 0.017 in.
		Allowable limit	1.25 mm 0.0492 in.
	Oil ring	Factory spec.	0.25 to 0.40 mm 0.0099 to 0.015 in.
		Allowable limit	1.25 mm 0.0492 in.

W10310120

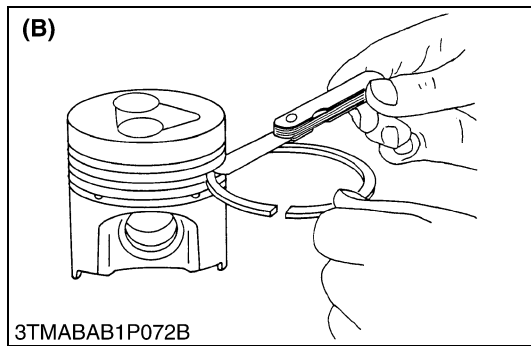
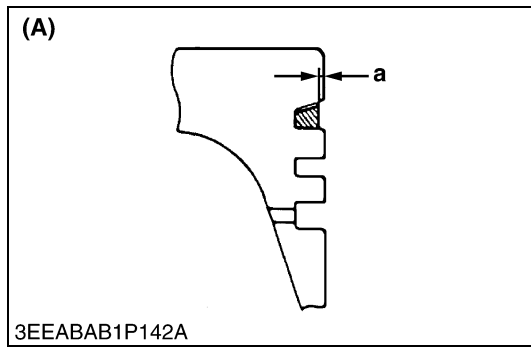

Clearance between Piston ring and Piston Ring Groove

1. Clean the rings and the ring grooves, and install each ring in its groove.
2. Measure the clearance between the ring and the groove with a feeler gauge or depth gauge.
3. If the clearance exceeds the allowable limit, replace the piston ring.
4. If the clearance still exceeds the allowable limit with new ring, replace the piston.

[BX1860, BX2360]

Clearance between piston ring and piston ring groove	Second ring	Factory spec.	0.0900 to 0.120 mm 0.00355 to 0.00472 in.
		Allowable limit	0.15 mm 0.0059 in.
	Oil ring	Factory spec.	0.040 to 0.080 mm 0.0016 to 0.0031 in.
		Allowable limit	0.15 mm 0.0059 in.

[BX2660]

Clearance between piston ring and piston ring groove	Second ring	Factory spec.	0.0850 to 0.112 mm 0.00335 to 0.00440 in.
		Allowable limit	0.2 mm 0.008 in.
	Oil ring	Factory spec.	0.020 to 0.055 mm 0.00079 to 0.0021 in.
		Allowable limit	0.15 mm 0.0059 in.

Factory specification : a	More than 0.2 mm 0.008 in.
---------------------------	-------------------------------

(A) Top Ring (Key Stone Type)

(B) 2nd Oil Ring

W10312390

(4) Crankshaft

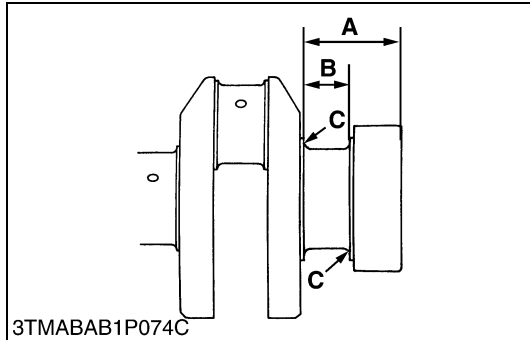
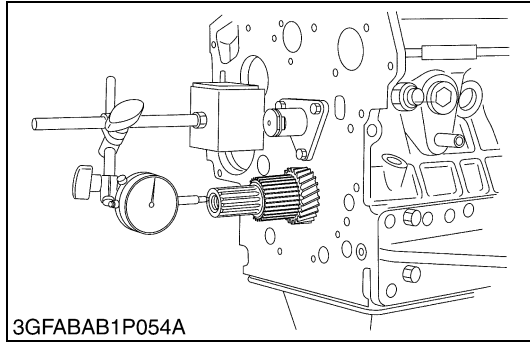

Crankshaft Side Clearance

1. Set a dial indicator with its tip on the end of the crankshaft.
2. Measure the side clearance by moving the crankshaft to the front and rear.
3. If the measurement exceeds the allowable limit, replace the thrust bearings.
4. If the same size bearing is useless because of the crankshaft journal wear, replace it with an oversize one referring to the table and figure.

Crankshaft side clearance	Factory spec.	0.15 to 0.31 mm 0.0059 to 0.012 in.
	Allowable limit	0.50 mm 0.020 in.

(Reference)

[BX1860, BX2360]

- Oversize thrust bearing

Oversize	Bearing	Code Number	Marking
0.20 mm 0.0079 in.	Thrust bearing 1 02	15261-23950	020 OS
	Thrust bearing 2 02	15261-23970	020 OS
0.40 mm 0.016 in.	Thrust bearing 1 04	15261-23960	040 OS
	Thrust bearing 2 04	15261-23980	040 OS

- Oversize dimensions of crankshaft journal

Oversize	0.20 mm 0.0079 in.	0.40 mm 0.016 in.
Dimension A	46.10 to 46.30 mm 1.815 to 1.822 in.	46.30 to 46.50 mm 1.823 to 1.830 in.
Dimension B	23.40 to 23.45 mm 0.9213 to 0.9232 in.	23.80 to 23.85 mm 0.9370 to 0.9389 in.
Dimension C	1.8 to 2.2 mm radius 0.071 to 0.086 in. radius	1.8 to 2.2 mm radius 0.071 to 0.086 in. radius
(0.8S)		
The crankshaft journal must be fine-finished to higher than ∇∇∇∇.		

[BX2660]

Oversize	0.20 mm 0.0079 in.	0.40 mm 0.016 in.
Dimension A	51.50 to 51.70 mm 2.028 to 2.035 in.	51.60 to 51.80 mm 2.032 to 2.039 in.
Dimension B	28.20 to 28.25 mm 1.111 to 1.112 in.	28.40 to 28.45 mm 1.119 to 1.120 in.
Dimension C	2.3 to 2.7 mm radius 0.091 to 0.10 in. radius	2.3 to 2.7 mm radius 0.091 to 0.10 in. radius
(0.8-S)		
The crankshaft journal must be fine-finished to higher than ∇∇∇∇		

W10317070

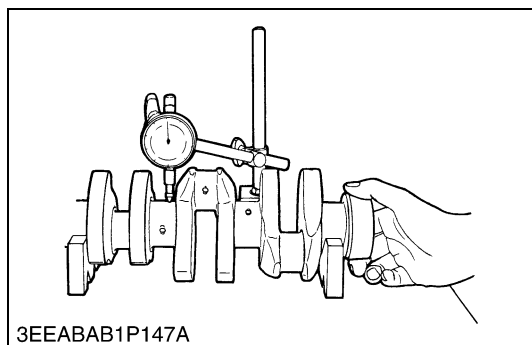

Crankshaft Alignment

1. Support the crankshaft with V blocks on the surface plate at both end journals.
2. Set a dial indicator with its tip on the intermediate journal.
3. Measure the crankshaft alignment.
4. If the measurement exceeds the allowable limit, replace the crankshaft.

Crankshaft alignment	Allowable limit	0.02 mm 0.0008 in.
----------------------	-----------------	-----------------------

W10330010

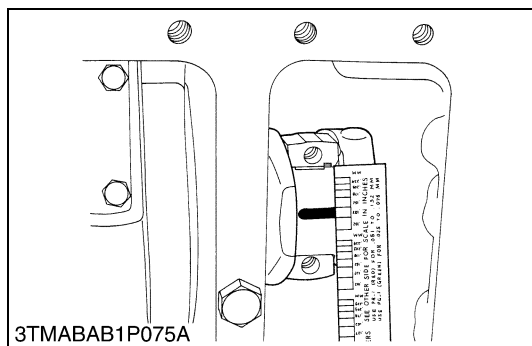

Oil Clearance between Crankpin and Crankpin Bearing (BX1860, BX2360)

1. Clean the crankpin and crankpin bearing.
2. Put a strip of plastigage on the center of the crankpin.
3. Install the connecting rod cap and tighten the connecting rod screws to the specified torque, and remove the cap again.
4. Measure the amount of the flattening with the scale, and get the oil clearance.
5. If the oil clearance exceeds the allowable limit, replace the crankpin bearing.
6. If the same size bearing is useless because of the crankpin wear, replace it with an undersize one referring to the table and figure.

NOTE

- Never insert the plastigage into the crankpin oil hole.
- Be sure not to move the crankshaft while the connecting rod screws are tightened.

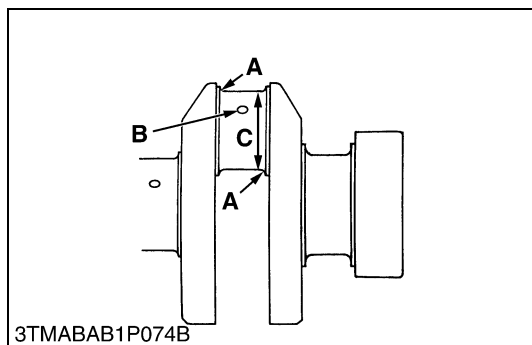

Oil clearance between crankpin and crankpin bearing	Factory spec.	0.020 to 0.051mm 0.00079 to 0.0020 in.
	Allowable limit	0.15 mm 0.0059 in.

Crankpin O.D.	Factory spec.	33.959 to 33.975 mm 1.3370 to 1.3375 in.
---------------	---------------	---

Crankpin bearing I.D.	Factory spec.	33.995 to 34.010 mm 1.3384 to 1.3389 in.
-----------------------	---------------	---

(Reference)

- Undersize crankpin bearing

Undersize	Bearing	Code Number	Marking
0.20 mm 0.0079 in.	Crankpin bearing 02	15861-22970	020 US
0.40 mm 0.016 in.	Crankpin bearing 04	15861-22980	040 US

- Undersize dimensions of crankpin

Undersize	0.20 mm 0.0079 in.	0.40 mm 0.016 in.
Dimension A	2.3 to 2.7 mm radius 0.091 to 0.10 in. radius	2.3 to 2.7 mm radius 0.091 to 0.10 in. radius
*Dimension B	1.0 to 1.5 mm relief 0.040 to 0.059 in. relief	1.0 to 1.5 mm relief 0.040 to 0.059 in. relief
Dimension C	33.759 to 33.775 mm dia. 1.3291 to 1.3297 in. dia.	33.559 to 33.575 mm dia. 1.3213 to 1.3218 in. dia.

(0.8S)
The crankpin must be fine-finished to higher than ∇∇∇∇.
*Holes to be de-burred and edges rounded with 1.0 to 1.5 mm (0.040 to 0.059 in.) relief.

W11625390

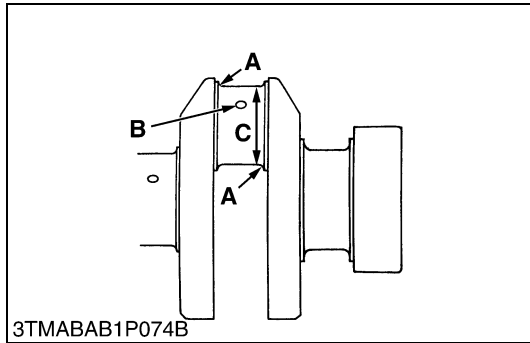
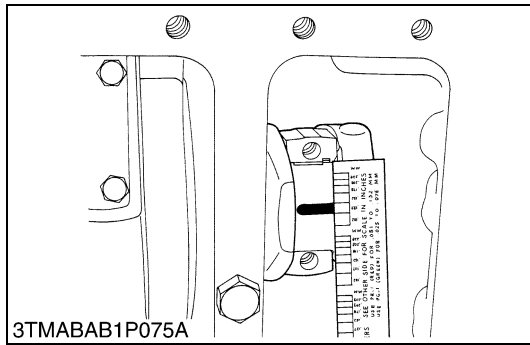

Oil Clearance between Crankpin and Crankpin Bearing (BX2660)

1. Clean the crankpin and crankpin bearing.
2. Put a strip of plastigage on the center of the crankpin.
3. Install the connecting rod cap and tighten the connecting rod screws to the specified torque, and remove the cap again.
4. Measure the amount of the flattening with the scale, and get the oil clearance.
5. If the oil clearance exceeds the allowable limit, replace the crankpin bearing.
6. If the same size bearing is useless because of the crankpin wear, replace it with an undersize one referring to the table and figure.

NOTE

- **Never insert the plastigage into the crankpin oil hole.**
- **Be sure not to move the crankshaft while the connecting rod screws are tightened.**

Oil clearance between crankpin and crankpin bearing	Factory spec.	0.029 to 0.091 mm 0.0011 to 0.0036 in.
	Allowable limit	0.20 mm 0.0079 in.

Crankpin O.D.	Factory spec.	39.959 to 39.975 mm 1.5732 to 1.5738 in.
---------------	---------------	---

Crankpin bearing I.D.	Factory spec.	40.040 to 40.050 mm 1.5764 to 1.5767 in.
-----------------------	---------------	---

(Reference)

- Undersize dimensions of crankpin

Undersize	0.20 mm 0.0079 in.	0.40 mm 0.016 in.
Dimension A	2.8 to 3.2 mm radius 0.11 to 0.12 in. radius	2.8 to 3.2 mm radius 0.11 to 0.12 in. radius
*Dimension B	1.0 to 1.5 mm relief 0.040 to 0.059 in. relief	1.0 to 1.5 mm relief 0.040 to 0.059 in. relief
Dimension C	39.759 to 39.775 mm dia. 1.5654 to 1.5659 in. dia.	39.559 to 39.575 mm dia. 1.5575 to 1.5580 in. dia.

(0.8-S)

The crankpin must be fine-finished to higher than ∇∇∇∇
 *Holes to be de-burred and edges rounded with 1.0 to 1.5 mm
 (0.040 to 0.059 in.) relief.

W10331060

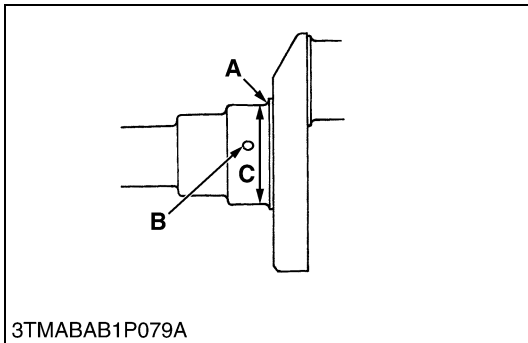
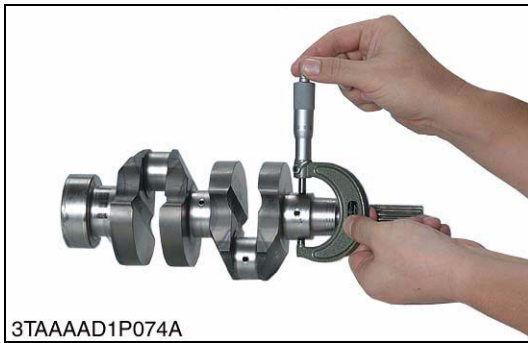

Oil Clearance between Crankshaft Journal and Crankshaft Bearing 1 (BX1860, BX2360)

1. Measure the O.D. of the crankshaft front journal with an outside micrometer.
2. Measure the I.D. of the crankshaft bearing 1 with an inside micrometer, and calculate the oil clearance.
3. If the oil clearance exceeds the allowable limit, replace the crankshaft bearing 1.
4. If the same size bearing is useless because of the crankshaft journal wear, replace it with an undersize one referring to the table and the figure.

Oil Clearance between crankshaft journal and crankshaft bearing 1	Factory spec.	0.0340 to 0.106 mm 0.00134 to 0.00417 in.
	Allowable limit	0.20 mm 0.0079 in.

Crankshaft journal O.D.	Factory spec.	BX1860	39.934 to 39.950 mm 1.5722 to 1.5728 in.
		BX2360	43.934 to 43.950 mm 1.7297 to 1.7303 in.
Crankshaft bearing 1 I.D.	Factory spec.	BX1860	39.984 to 40.040 mm 1.5742 to 1.5763 in.
		BX2360	43.984 to 44.040 mm 1.7317 to 1.7338 in.

(Reference)

- Undersize crankshaft bearing 1

Undersize	Models	Bearing	Code Number	Marking
0.20 mm 0.0079 in.	BX1860	Crankshaft bearing 1 02	15861-23910	020 US
	BX2360		1G460-23910	
0.40 mm 0.016 in.	BX1860	Crankshaft bearing 1 04	15861-23920	040 US
	BX2360		1G460-23920	

- Undersize dimensions of crankshaft journal

Undersize	Models	0.20 mm 0.0079 in.	0.40 mm 0.016 in.
Dimension A	All models	1.8 to 2.2 mm radius 0.071 to 0.086 in. radius	1.8 to 2.2 mm radius 0.071 to 0.086 in. radius
*Dimension B	All models	1.0 to 1.5 mm relief 0.040 to 0.059 in. relief	1.0 to 1.5 mm relief 0.040 to 0.059 in. relief
Dimension C	BX1860	39.734 to 39.750 mm dia. 1.5644 to 1.5649 in. dia.	39.534 to 39.550 mm dia. 1.5565 to 1.5570 in. dia.
	BX2360	43.734 to 43.750 mm dia. 1.7219 to 1.7224 in. dia.	43.534 to 43.550 mm dia. 1.7140 to 1.7145 in. dia.

(0.8S)
The crankshaft journal must be fine-finished to higher than ∇∇∇∇.
*Holes to be de-burred and edges rounded with 1.0 to 1.5 mm (0.040 to 0.059 in.) relief.

W10323470

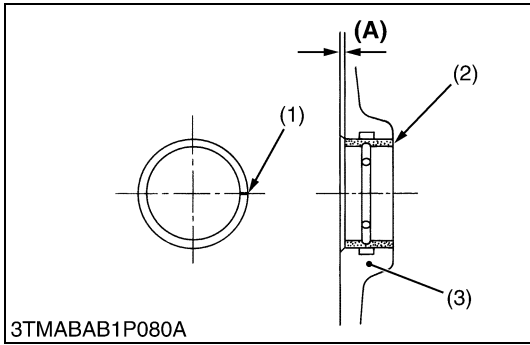
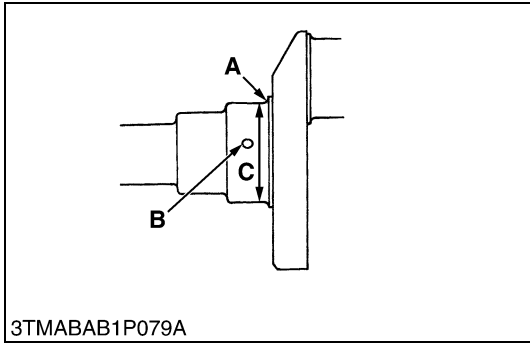
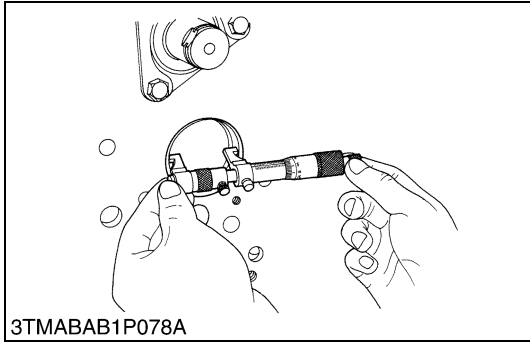
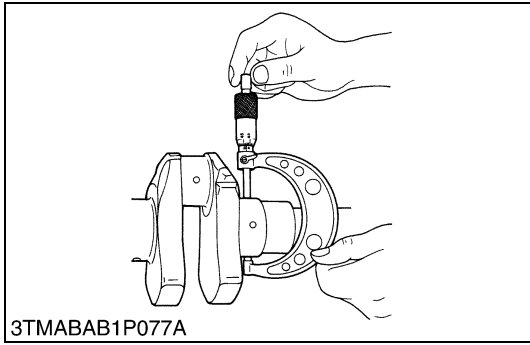

Oil Clearance between Crankshaft Journal and Crankshaft Bearing 1 (BX2660)

1. Measure the O.D. of the crankshaft front journal with an outside micrometer.
2. Measure the I.D. of the crankshaft bearing 1 with an inside micrometer, and calculate the oil clearance.
3. If the clearance exceeds the allowable limit, replace the crankshaft bearing 1.
4. If the same size bearing is useless because of the crankshaft journal wear, replace it with an undersize one referring to the table and figure.

Oil clearance between crankshaft journal and crankshaft bearing 1	Factory spec.	0.0340 to 0.114 mm 0.00134 to 0.00448 in.
	Allowable limit	0.20 mm 0.0079 in.

Crankshaft journal O.D.	Factory spec.	47.934 to 47.950 mm 1.8872 to 1.8877 in.
Crankshaft bearing 1 I.D.	Factory spec.	47.984 to 48.048 mm 1.8892 to 1.8916 in.

(Reference)

- Undersize dimensions of crankshaft journal

Undersize	0.020 mm 0.0079 in.	0.40 mm 0.016 in.
Dimension A	2.3 to 2.7 mm radius 0.091 to 0.10 in. radius	2.3 to 2.7 mm radius 0.091 to 0.10 in. radius
*Dimension B	1.0 to 1.5 mm relief 0.040 to 0.059 in. relief	1.0 to 1.5 mm relief 0.040 to 0.059 in. relief
Dimension C	47.734 to 47.750 mm dia. 1.8793 to 1.8799 in. dia.	47.534 to 47.550 mm dia. 1.8715 to 1.8720 in. dia.
(0.8-S) The crankshaft journal must be fine-finished to higher than ∇∇∇∇ *Holes to be de-burred and edges rounded with 1.0 to 1.5 mm (0.040 to 0.059 in.) relief.		

W10337170

Replacing Crankshaft Bearing 1

(When removing)

1. Press out the used crankshaft bearing 1 using a crankshaft bearing 1 replacing tool. (See page “SPECIAL TOOLS”.)

(When installing)

1. Clean a new crankshaft bearing 1 and crankshaft journal bore, and apply engine oil to them.
2. Using a crankshaft bearing 1 replacing tool, press in a new bearing 1 (2) so that its seam (1) directs toward the exhaust manifold side. (See figure.)

Dimension (A)	Factory spec.	0 to 0.3 mm 0 to 0.01 in.
---------------	---------------	------------------------------

- (1) Seam
- (2) Crankshaft Bearing 1
- (3) Cylinder Block

(A) Dimension

W10339460

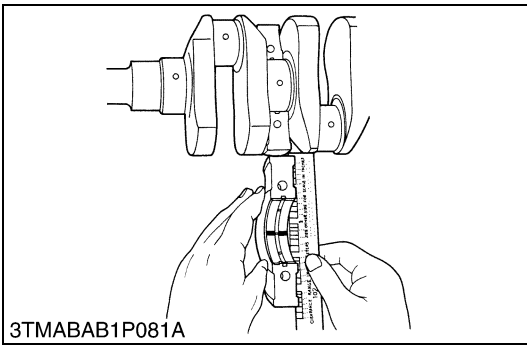

Oil Clearance between Crankshaft Journal and Crankshaft Bearing 2 and Crankshaft Bearing 3 (BX1860, BX2360)

1. Put a strip of plastigage on the center of the journal.
2. Install the bearing case and tighten the bearing case screws 1 to the specified torque, and remove the bearing case again.
3. Measure the amount of the flattening with the scale, and get the oil clearance.
4. If the oil clearance exceeds the allowable limit, replace the crankshaft bearing 2 (crankshaft bearing 3).
5. If the same size bearing is useless because of the crankshaft journal wear, replace it with an undersize one referring to the table and figure.

NOTE

- **Be sure not to move the crankshaft while the bearing case screws are tightened.**

Oil clearance between crankshaft journal and crankshaft bearing 2 (crankshaft bearing 3)	Factory spec.	0.028 to 0.059 mm 0.0011 to 0.0023 in.
	Allowable limit	0.20 mm 0.0079 in.

Crankshaft journal O.D. (Flywheel side)	Factory spec.	43.934 to 43.950 mm 1.7297 to 1.7303 in.
Crankshaft bearing 2 I.D.	Factory spec.	43.978 to 43.993 mm 1.7315 to 1.7320 in.

Crankshaft journal O.D. (Intermediate)	Factory spec.	BX1860	39.934 to 39.950 mm 1.5722 to 1.5728 in.
		BX2360	43.934 to 43.950 mm 1.7297 to 1.7303 in.
Crankshaft bearing 3 I.D.	Factory spec.	BX1860	39.978 to 39.993 mm 1.5740 to 1.5745 in.
		BX2360	43.978 to 43.993 mm 1.7315 to 1.7320 in.

W10344030

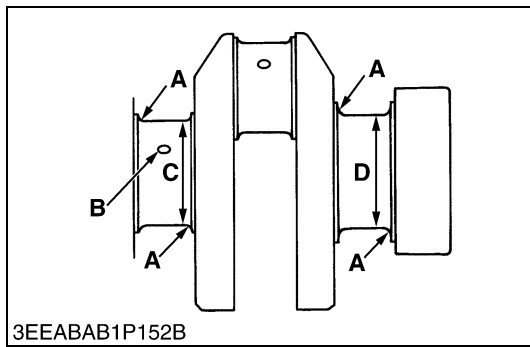

Oil Clearance between Crankshaft Journal and Crankshaft Bearing 2 and Crankshaft Bearing 3 (BX1860, BX2360) (Continued)

(Reference)

- Undersize crankshaft bearing 2 and 3 (0.20 mm (0.0079 in.))

Models	Bearing	Code Number	Marking
BX1860	Crankshaft bearing 2 02	15694-23930	020 US
	Crankshaft bearing 3 02	15861-23860	
BX2360	Crankshaft bearing 2 02	1G460-23930	
	Crankshaft bearing 3 02	1G460-23940	

- Undersize crankshaft bearing 2 and 3 (0.40 mm (0.016 in.))

Models	Bearing	Code Number	Marking
BX1860	Crankshaft bearing 2 04	15694-23940	040 US
	Crankshaft bearing 3 04	15861-23870	
BX2360	Crankshaft bearing 2 04	1G460-23950	
	Crankshaft bearing 3 04	1G460-23960	

- Undersize dimensions of crankshaft journal

Undersize	Models	0.20 mm 0.0079 in.	0.40 mm 0.016 in.
Dimension A	All models	1.8 to 2.2 mm radius 0.071 to 0.086 in. radius	1.8 to 2.2 mm radius 0.071 to 0.086 in. radius
*Dimension B	All models	1.0 to 1.5 mm relief 0.040 to 0.059 in. relief	1.0 to 1.5 mm relief 0.040 to 0.059 in. relief
Dimension C	BX1860	39.734 to 39.750 mm dia. 1.5644 to 1.5649 in. dia.	39.534 to 39.550 mm dia. 1.5565 to 1.5570 in. dia.
	BX2360	43.734 to 43.750 mm dia. 1.7219 to 1.7224 in. dia.	43.534 to 43.550 mm dia. 1.7140 to 1.7145 in. dia.
Dimension D	All models	43.734 to 43.750 mm dia. 1.7219 to 1.7224 in. dia.	43.534 to 43.550 mm dia. 1.7140 to 1.7145 in. dia.

(0.8S)

The crankshaft journal must be fine-finished to higher than ∇∇∇∇.

*Holes to be de-burred and edges rounded with 1.0 to 1.5 mm (0.040 to 0.059 in.) relief.

W1047088

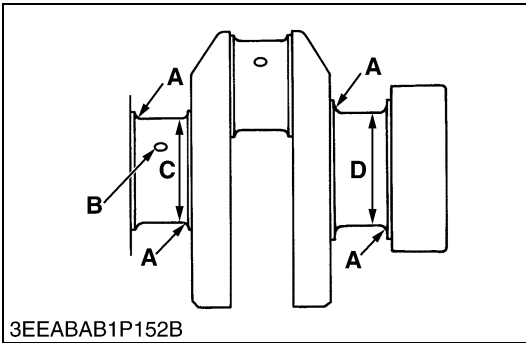
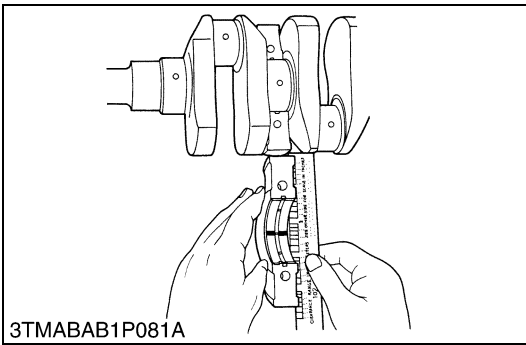

Oil Clearance between Crankshaft Journal and Crankshaft Bearing 2 (Crankshaft Bearing 3) (BX2660)

1. Put a strip of plastigage on the center of the journal.
2. Install the bearing case and tighten the bearing case screws 1 to the specified torque, and remove the bearing case again.
3. Measure the amount of the flattening with the scale and get the oil clearance.
4. If the clearance exceeds the allowable limit, replace the crankshaft bearing 2 (1) and crankshaft bearing (3).
5. If the same size bearing is useless because of the crankshaft journal wear, replace it with an undersize one referring to the table and figure.

NOTE

- Be sure not to move the crankshaft while the bearing case screws are tightened.

Oil clearance between crankshaft journal and crankshaft bearing 2	Factory spec.	0.034 to 0.095 mm 0.0014 to 0.0037 in.
	Allowable limit	0.20 mm 0.0079 in.

Crankshaft journal O.D. (Intermediate)	Factory spec.	47.934 to 47.950 mm 1.8872 to 1.8877 in.
Crankshaft bearing 2 I.D.	Factory spec.	47.984 to 48.029 mm 1.8892 to 1.8909 in.

Oil clearance between crankshaft journal and crankshaft bearing 3	Factory spec.	0.034 to 0.098 mm 0.0013 to 0.0038 in.
	Allowable limit	0.20 mm 0.0079 in.

Crankshaft journal O.D. (Flywheel side)	Factory spec.	51.921 to 51.940 mm 2.0442 to 2.0448 in.
Crankshaft bearing 3 I.D.	Factory spec.	51.974 to 52.019 mm 2.0463 to 2.0479 in.

(Reference)

- Undersize dimensions of crankshaft journal

Undersize	0.20 mm 0.0079 in.	0.40 mm 0.016 in.
Dimension A	2.3 to 2.7 mm radius 0.091 to 0.10 in. radius	2.3 to 2.7 mm radius 0.091 to 0.10 in. radius
*Dimension B	1.0 to 1.5 mm relief 0.040 to 0.0591 in. relief	1.0 to 1.5 mm relief 0.040 to 0.0591 in. relief
Dimension C	47.734 to 47.750 mm dia. 1.8793 to 1.8799 in. dia.	47.534 to 47.550 mm dia. 1.8715 to 1.8720 in. dia.
Dimension D	51.721 to 51.740 mm dia. 2.0362 to 2.0370 in. dia.	51.521 to 51.540 mm dia. 2.0284 to 2.0291 in. dia.

(0.8-S)
The crankshaft journal must be fine-finished to higher than $\nabla\nabla\nabla\nabla$
*Holes to be de-burred and edges rounded with 1.0 to 1.5 mm (0.040 to 0.059 in.) relief.

W10340750

(5) Cylinder

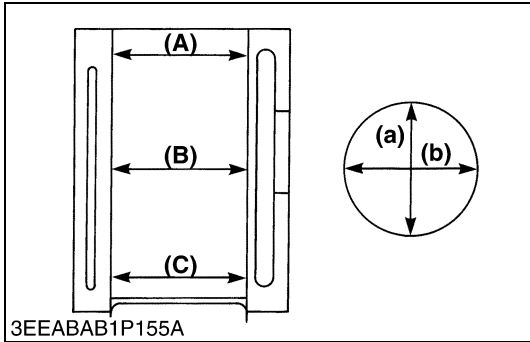
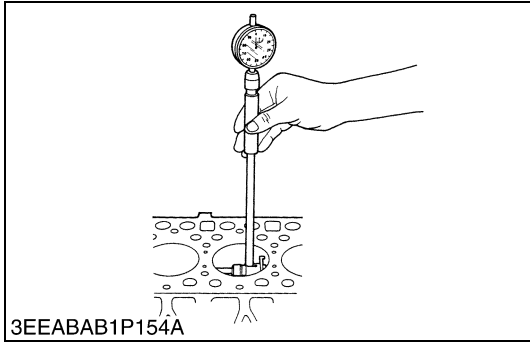

Cylinder Wear

1. Measure the I.D. of the cylinder at the six positions (see figure) with a cylinder gauge to find the maximum and minimum I.D.'s.
2. Get the difference (Maximum wear) between the maximum and the minimum I.D.'s.
3. If the wear exceeds the allowable limit, bore and hone to the oversize dimension. (Refer to **“Correcting Cylinder”**.)
4. Visually check the cylinder wall for scratches. If deep scratches are found, the cylinder should be bored. (Refer to **“Correcting Cylinder”**.)

Cylinder liner I.D.	Factory spec.	BX1860	67.000 to 67.019 mm 2.6378 to 2.6385 in.
		BX2360	72.000 to 72.019 mm 2.8347 to 2.8353 in.
		BX2660	76.000 to 76.019 mm 2.9922 to 2.9929 in.
	Allowable limit	BX1860	67.150 mm 2.6437 in.
		BX2360	72.150 mm 2.8406 in.
		BX2660	76.15 mm 2.998 in.

- (A) Top
- (B) Middle
- (C) Bottom (Skirt)

- (a) Right-angled to Piston Pin
- (b) Piston Pin Direction

W10343890

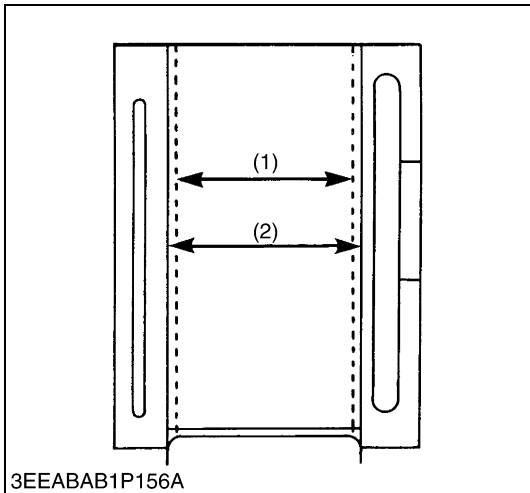

Correcting Cylinder (Oversize) (BX1860, BX2360)

1. When the cylinder is worn beyond the allowable limit, bore and hone it to the specified dimension.

Cylinder liner I.D.	Factory spec.	BX1860	67.250 to 67.269 mm 2.6477 to 2.6483 in.
		BX2360	72.250 to 72.269 mm 2.8445 to 2.8452 in.
	Allowable limit	BX1860	67.400 mm 2.6535 in.
		BX2360	72.400 mm 2.8504 in.
Finishing	Hone to 2.2 to 3.0 μm Rz (87 to 110 μin. Rz) ▽▽▽.		

2. Replace the piston and piston rings with oversize ones.
Oversize : 0.25 mm (0.0098 in.)
Marking : 025

NOTE

- When the oversize cylinder is worn beyond the allowable limit, replace the cylinder block with a new one.

(1) Cylinder I.D. (Before Correction) (2) Cylinder I.D. [Oversize]

W10367470

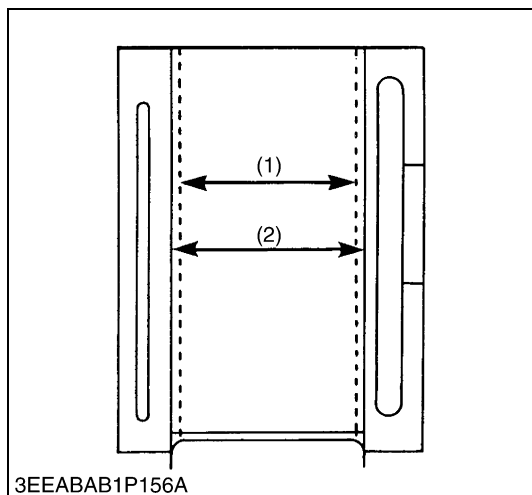

Correcting Cylinder (BX2660)

1. When the cylinder is worn beyond the allowable limit, bore and hone it to the specified dimension.

Oversized cylinder liner I.D.	Factory spec.	76.500 to 76.519 mm 3.0119 to 3.0125 in.
	Allowable limit	76.65 mm 3.018 in.

2. Replace the piston and piston rings with oversize ones.
Oversize : 0.5 mm (0.02 in.)

NOTE

- When the oversize cylinder is worn beyond the allowable limit, replace the cylinder block with a new one.

(1) Cylinder I.D. (Before Correction) (2) Cylinder I.D. (Oversize)

W10344480

(6) Oil Pump (BX1860, BX2360)



Rotor Lobe Clearance

1. Measure the clearance between lobes of the inner rotor and the outer rotor with a thickness gauge.
2. If the clearance exceeds the factory specifications, replace the oil pump rotor assembly.

Rotor lobe clearance	Factory spec.	0.030 to 0.14 mm 0.0012 to 0.0055 in.
----------------------	---------------	--

W10378950



Clearance between Outer Rotor and Pump Body

1. Measure the clearance between the outer rotor and the pump body with a thickness gauge.
2. If the clearance exceeds the factory specifications, replace the oil pump rotor assembly.

Clearance between outer rotor and pump body	Factory spec.	0.070 to 0.15 mm 0.0028 to 0.0059 in.
---	---------------	--

W10381420

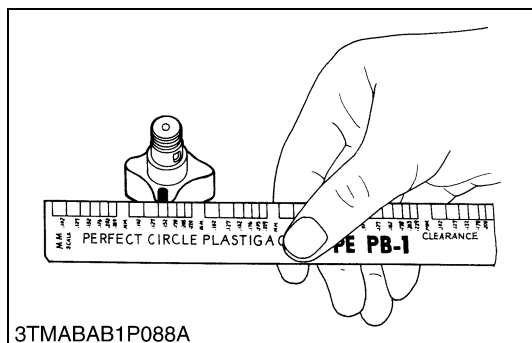

Clearance between Rotor and Cover

1. Put a strip of plastigage onto the rotor face with grease.
2. Install the cover and tighten the screws.
3. Remove the cover carefully, and measure the amount of the flattening with the scale and get the clearance.
4. If the clearance exceeds the factory specifications, replace oil pump rotor assembly.

Clearance between rotor and cover	Factory spec.	0.0750 to 0.135 mm 0.00296 to 0.00531 in.
-----------------------------------	---------------	--

W10382660

(7) Oil Pump (BX2660)

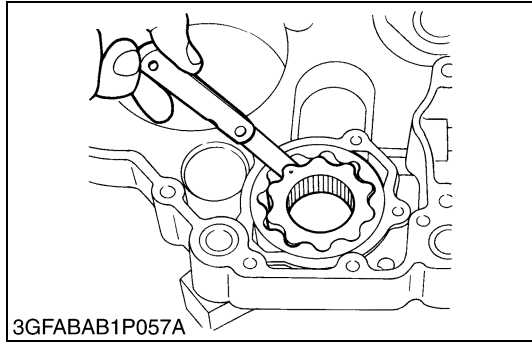

Rotor Lobe Clearance

1. Measure the clearance between lobes of the inner rotor and the outer rotor with a feeler gauge.
2. If the clearance exceeds the factory specifications, replace the oil pump rotor assembly.

Rotor lobe clearance	Factory spec.	0.060 to 0.18 mm 0.0024 to 0.0071 in.
----------------------	---------------	--

W10355630

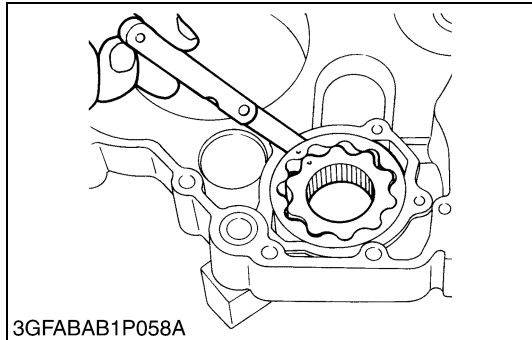

Clearance between Outer Rotor and Pump Body

1. Measure the clearance between the outer rotor and the pump body with a feeler gauge.
2. If the clearance exceeds the factory specifications, replace the oil pump rotor assembly.

Clearance between outer rotor and pump body	Factory spec.	0.100 to 0.180 mm 0.00394 to 0.00708 in.
---	---------------	---

W10356560

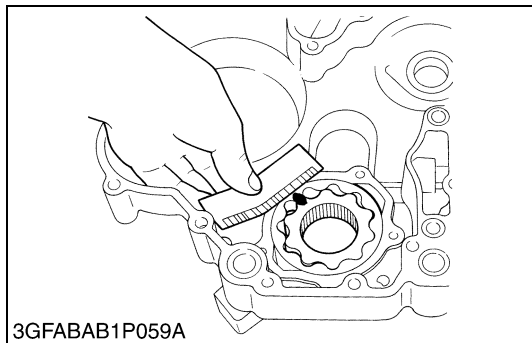

Clearance between Rotor and Cover

1. Put a strip of plastigage onto the rotor face with grease.
2. Install the cover and tighten the screws.
3. Remove the cover carefully, and measure the amount of the flattening with the scale and get the clearance.
4. If the clearance exceeds the factory specifications, replace the oil pump rotor assembly.

Clearance between rotor and cover	Factory spec.	0.025 to 0.075 mm 0.00099 to 0.0029 in.
-----------------------------------	---------------	--

W10357320

2 TRANSAXLE

MECHANISM

CONTENTS

1. STRUCTURE	2-M1
2. TRAVELING SYSTEM	2-M2
[1] HYDROSTATIC TRANSMISSION	2-M2
(1) Structure	2-M2
(2) Oil Flow	2-M3
(3) HST Control Linkage.....	2-M8
(4) Speed Set Linkage.....	2-M9
[2] RANGE GEAR SHIFT SECTION.....	2-M11
[3] FRONT WHEEL DRIVE SECTION.....	2-M11
[4] DIFFERENTIAL GEAR SECTION	2-M12
(1) Differential Gears	2-M12
(2) Differential Lock	2-M13
[5] BRAKE SECTION	2-M14
3. PTO SYSTEM	2-M15
[1] PTO CLUTCH AND VALVE.....	2-M15
[2] MID AND REAR PTO SECTION.....	2-M18
4. OTHERS	2-M19
[1] HYDRAULIC PUMP DRIVE GEAR SECTION.....	2-M19

1. STRUCTURE

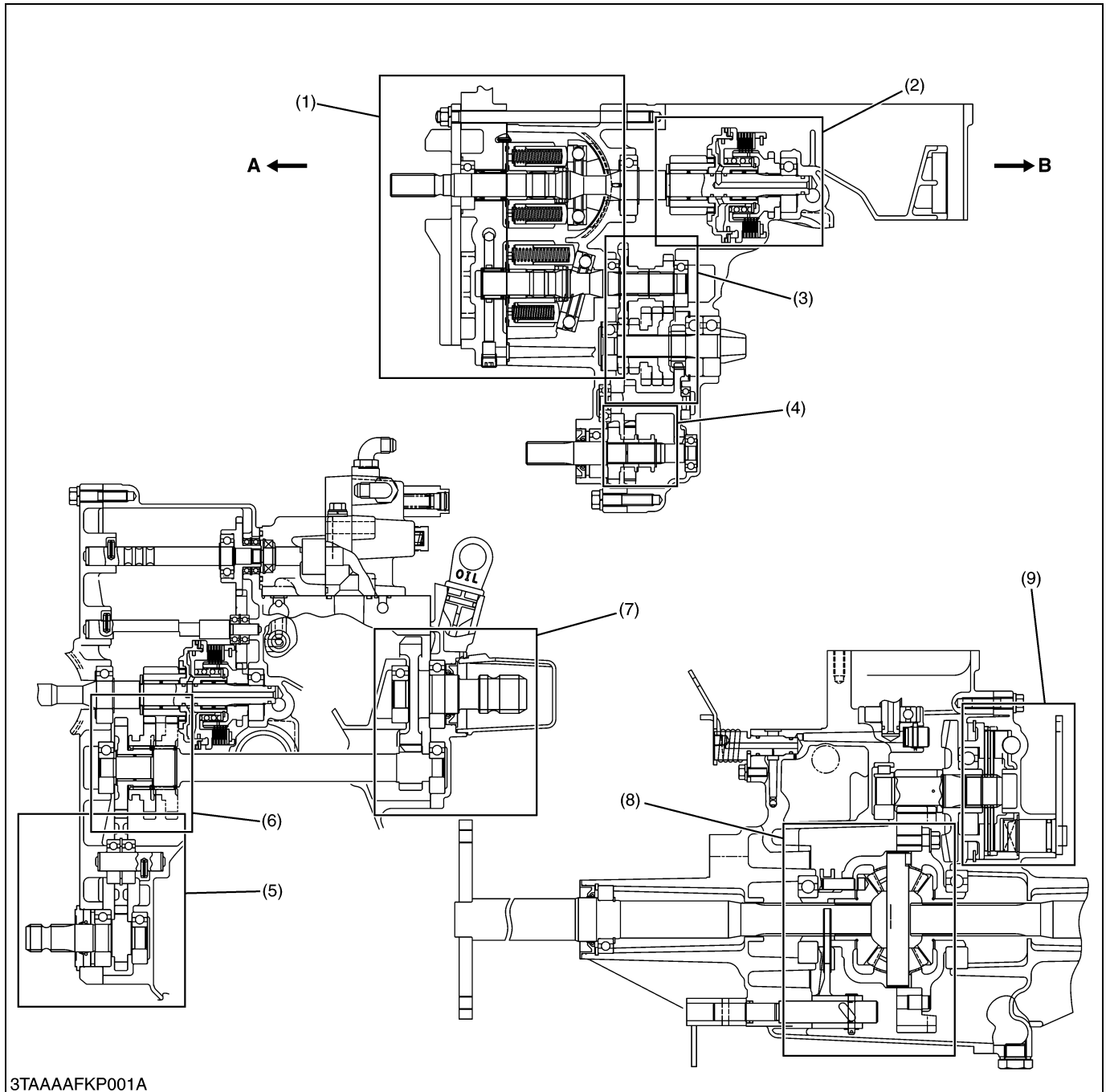

3TAAAFKP001A

- (1) Hydrostatic Transmission
- (2) PTO Clutch Section
- (3) Range Gear Shift Section

- (4) Front Wheel Drive Gear Section
- (5) Mid-PTO Section
- (6) PTO Gear Shift Section

- (7) Rear PTO Section
- (8) Differential Gear Section
- (9) Brake Section

A : Front Side
B : Rear Side

2. TRAVELING SYSTEM

[1] HYDROSTATIC TRANSMISSION

(1) Structure

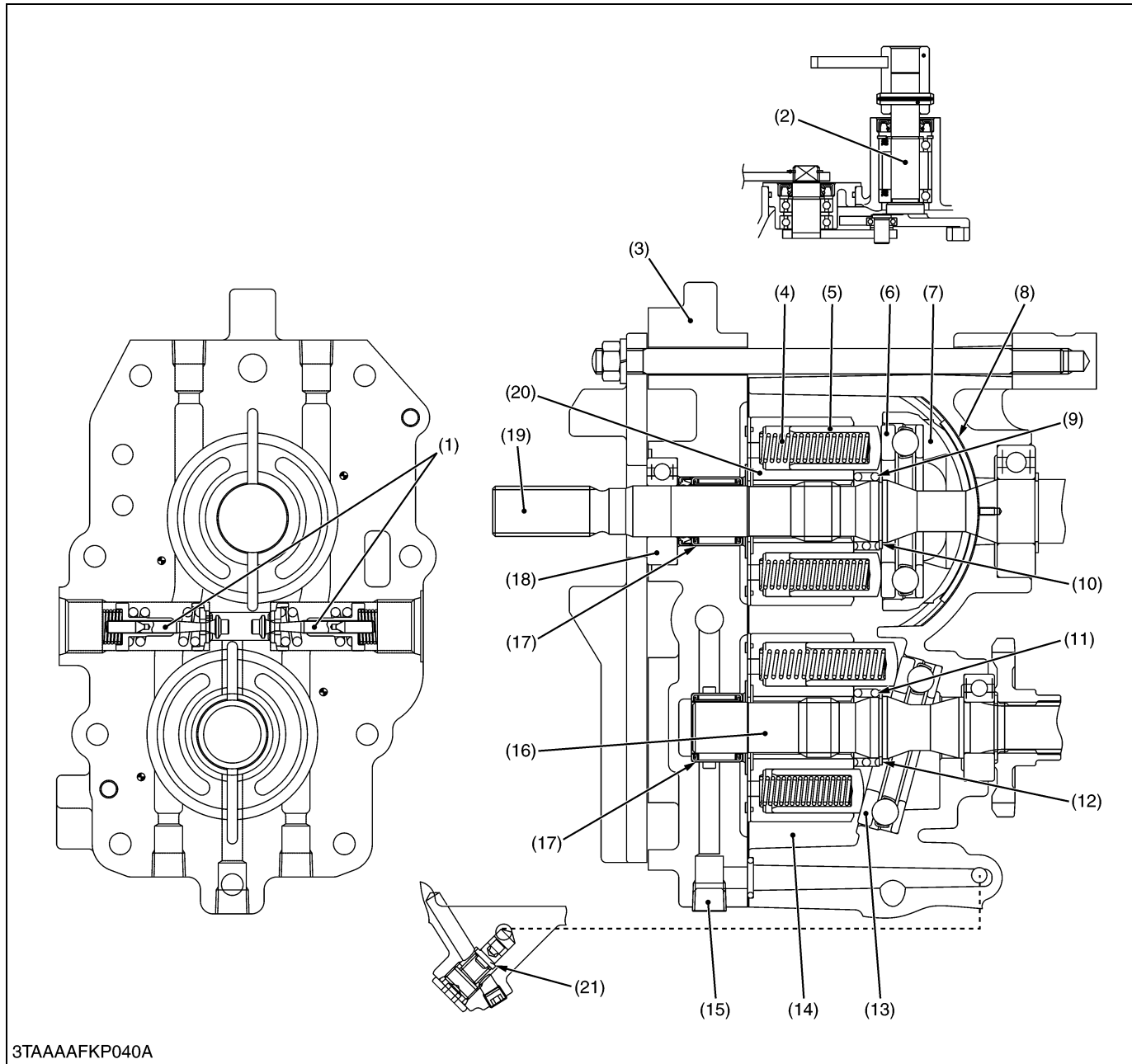

- | | | | |
|--|-------------------------|-----------------------------|----------------------------|
| (1) Check and High Pressure Relief Valve | (6) Thrust Ball Bearing | (12) Cir-Clip | (17) Needle Bearing |
| (2) Trunnion Arm | (7) Swashplate | (13) Thrust Ball Bearing | (18) Ball Bearing |
| (3) Center Section | (8) Cradle Bearing | (14) Cylinder Block (Motor) | (19) Pump Shaft |
| (4) Piston Spring | (9) Spring | (15) Plug | (20) Cylinder Block (Pump) |
| (5) Piston | (10) Cir-Clip | (16) Motor Shaft | (21) Charge Relief Valve |
| | (11) Spring | | |

The hydrostatic transmission consists of variable displacement piston pump, fixed displacement piston motor and valve system.

(2) Oil Flow

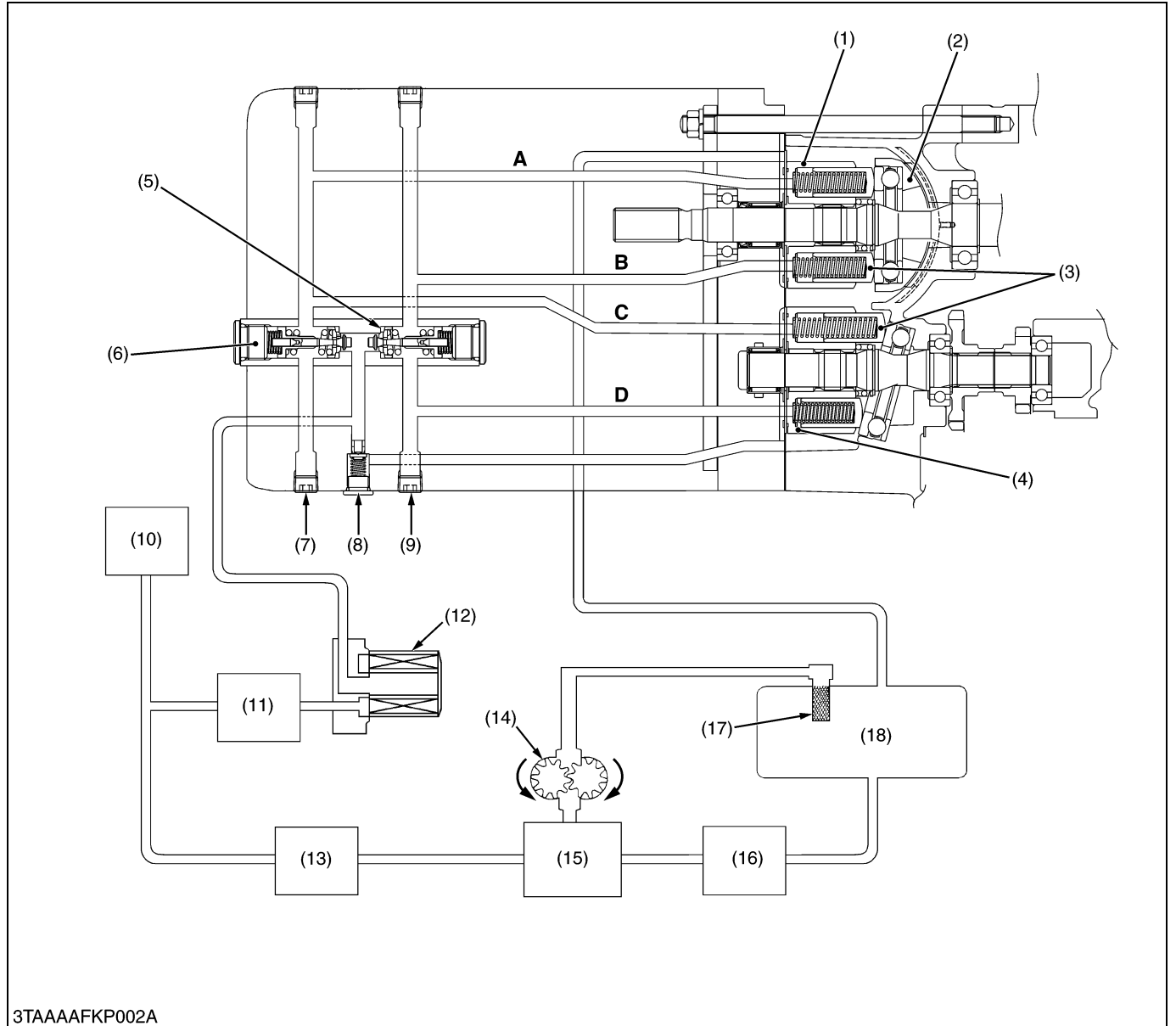

- | | | | |
|--|--|--|-------------------|
| (1) Cylinder Block (Pump) | (7) High Pressure Relief Port Plug (Forward) | (13) Power Steering Controller | A : A Port |
| (2) Swashplate | (8) Charge Relief Valve | (14) Hydraulic Pump | B : B Port |
| (3) Piston | (9) High Pressure Relief Port Plug (Reverse) | (15) Flow Priority Valve (Hydraulic Control Valve) | C : C Port |
| (4) Cylinder Block (Motor) | (10) PTO Clutch Valve | (16) Position Control Valve | D : D Port |
| (5) Check and High Pressure Relief Valve (Forward) | (11) PTO Relief Valve | (17) Oil Strainer | |
| (6) Check and High Pressure Relief Valve (Reverse) | (12) Oil Filter Cartridge | (18) Transmission Case | |

The pump and motor are joined in a closed hydraulic loop and most of oil circulates within the main oil circuit. A little oil lubricates and oozes out from the clearance between the moving parts of the case. Then oil in the main oil circuit of the HST needs to be supplied a want.

The oil from the power steering circuit flows into the HST for charging.

The charge oil aids smooth operation of pistons for pump and motor. The charge oil passes through the oil filter cartridge to charge relief valve port. The rest of oil passes through the charge relief valve into the HST housing. And overflow oil from HST housing return to the transmission case.

■ Forward

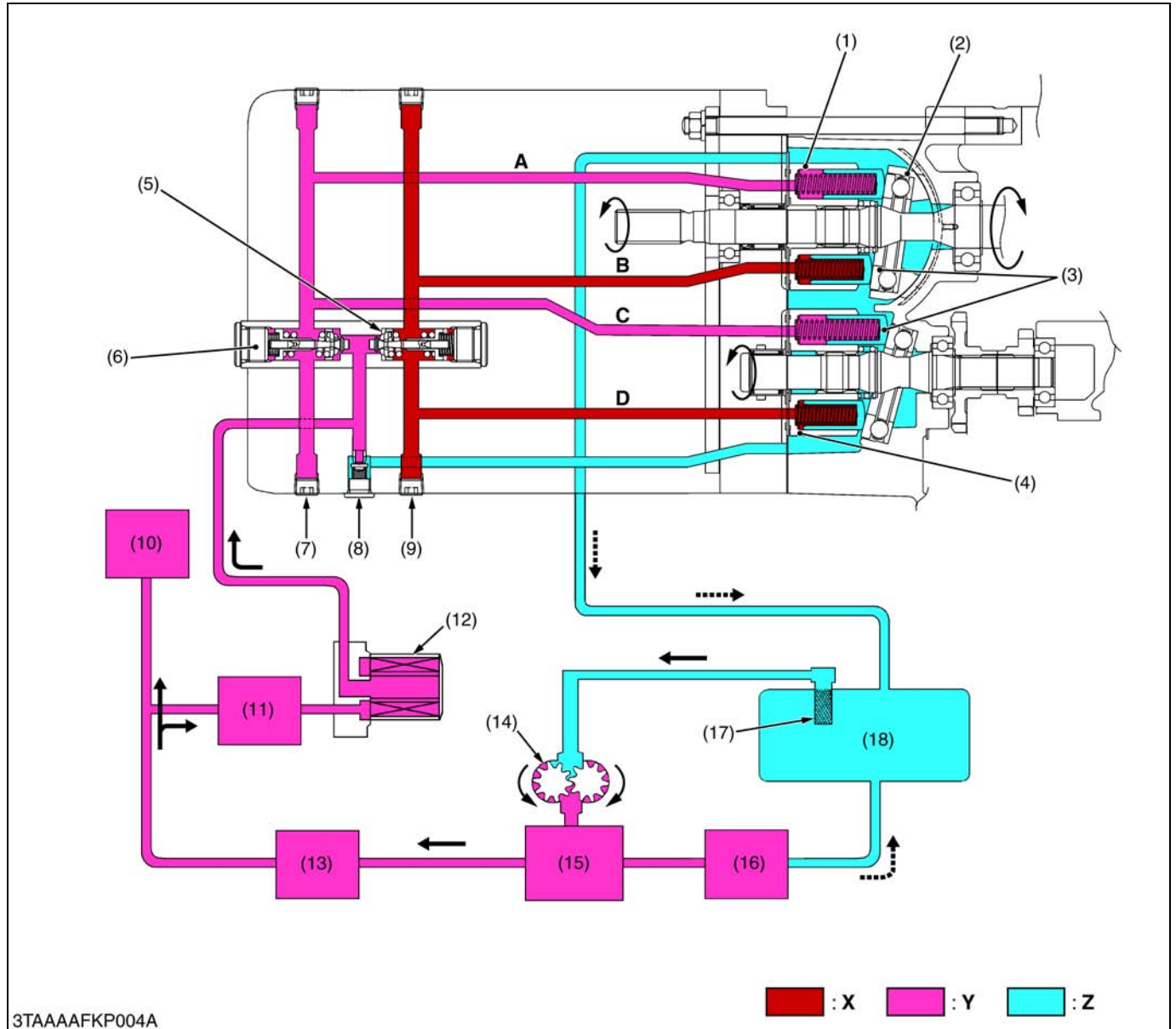

- | | | | |
|--|--|--|--------------------------|
| (1) Cylinder Block (Pump) | (7) High Pressure Relief Port Plug (Forward) | (13) Power Steering Controller | A : A Port |
| (2) Swashplate | (8) Charge Relief Valve | (14) Hydraulic Pump | B : B Port |
| (3) Piston | (9) High Pressure Relief Port Plug (Reverse) | (15) Flow Priority Valve (Hydraulic Control Valve) | C : C Port |
| (4) Cylinder Block (Motor) | (10) PTO Clutch Valve | (16) Position Control Valve | D : D Port |
| (5) Check and High Pressure Relief Valve (Forward) | (11) PTO Relief Valve | (17) Oil Strainer | X : High Pressure |
| (6) Check and High Pressure Relief Valve (Reverse) | (12) Oil Filter Cartridge | (18) Transmission Case | Y : Low Pressure |
| | | | Z : Free Oil |

When the speed control pedal is stepped on and in forward, the variable swashplate is tilted as shown in figure above.

As the pump cylinder block rotates with the input shaft, oil is forced out of pump port **B** at high pressure. As pressure oil enters motor port **D**, the pistons, which align with port **D**, are pushed against the swashplate and slide down the inclined surface.

Then the output shaft rotates with the motor cylinder block. This drives the machine forward and the angle of pump swashplate determines the output shaft speed.

As the motor cylinder block continues to rotate, oil is forced out of motor port **C** at low pressure and returns to the pump.

■ Relief (Reverse)

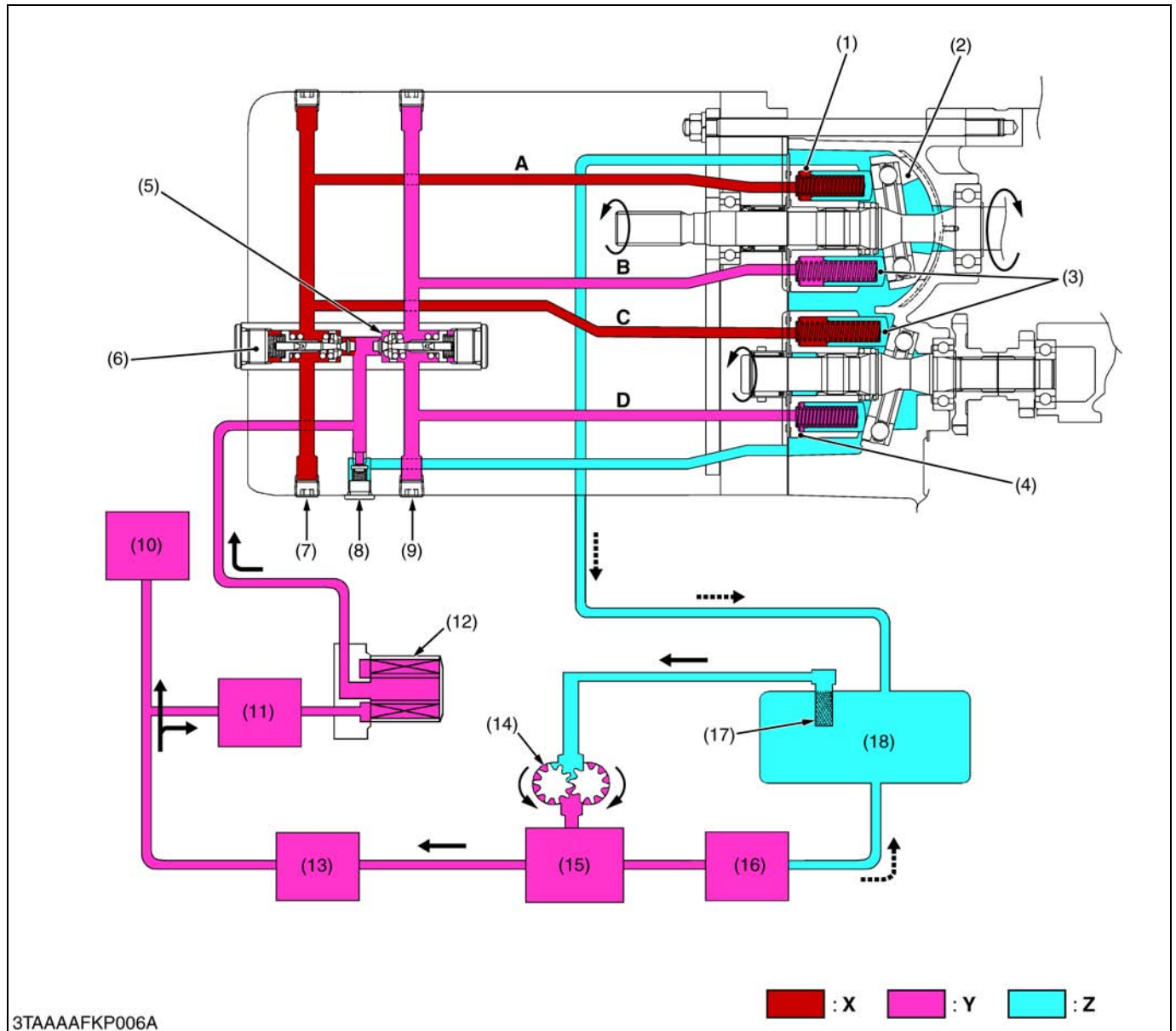

- | | | | |
|--|--|--|--------------------------|
| (1) Cylinder Block (Pump) | (7) High Pressure Relief Port Plug (Forward) | (13) Power Steering Controller | A : A Port |
| (2) Swashplate | (8) Charge Relief Valve | (14) Hydraulic Pump | B : B Port |
| (3) Piston | (9) High Pressure Relief Port Plug (Reverse) | (15) Flow Priority Valve (Hydraulic Control Valve) | C : C Port |
| (4) Cylinder Block (Motor) | (10) PTO Clutch Valve | (16) Position Control Valve | D : D Port |
| (5) Check and High Pressure Relief Valve (Forward) | (11) PTO Relief Valve | (17) Oil Strainer | X : High Pressure |
| (6) Check and High Pressure Relief Valve (Reverse) | (12) Oil Filter Cartridge | (18) Transmission Case | Y : Low Pressure |
| | | | Z : Free Oil |

When the speed control pedal is in reverse, the variable swashplate is tilted as shown in figure above.

As the pump cylinder block rotates with the input shaft, oil is forced out of pump port **A** at high pressure. As pressure oil enters motor port **C**, the pistons, which align with port **C**, are pushed against the swashplate and slide down the inclined surface. Since the oil pressure in the check and high pressure relief valve (Reverse) increase, the high oil pressure opens the check and high pressure relief valve (Reverse) and the flows through the charge relief valve to the transmission case.

Then the output shaft rotates with the motor cylinder block. This drives the machine rearward and the angle of pump swashplate determines the output shaft speed.

As the motor cylinder block continues to rotate, oil is forced out of motor port **D** at low pressure and returns to the pump.

(3) HST Control Linkage

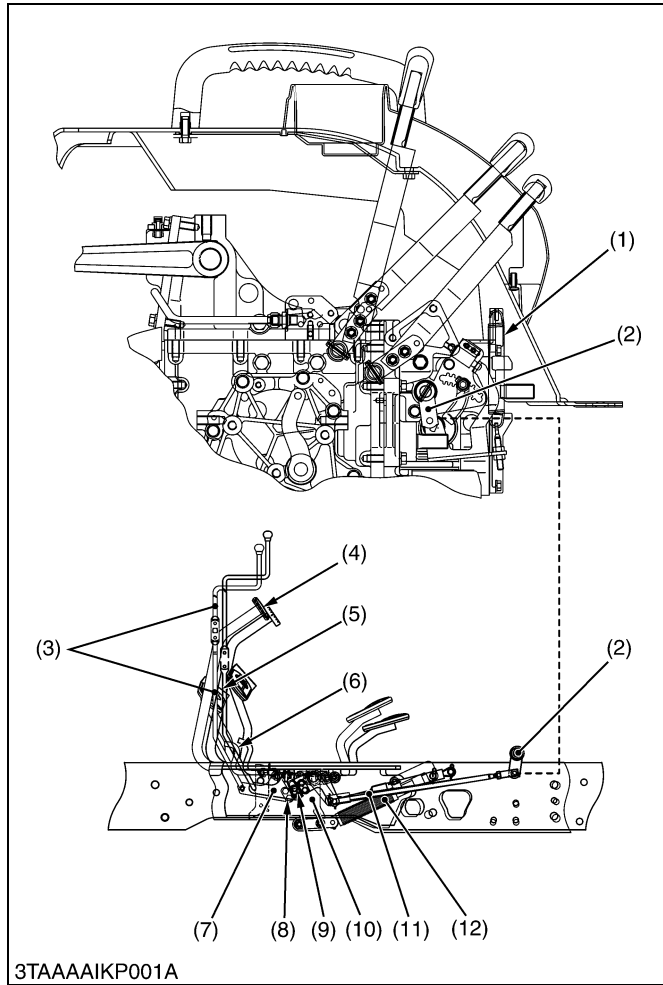

The speed control pedal (5) and the trunnion arm are linked with the HST pedal link (10) and the speed change rod (11). As the front of the pedal is depressed, the swashplate connected to the trunnion arm (2) rotates and forward travelling speed increases. Depressing the rear end increases reverse speed.

The trunnion arm (2) is returned to neutral position by the neutral arm and the tension of neutral spring. At the same time, the swashplate is returned to neutral, when the pedal is released. The damper (12) connected to the HST pedal link (10) restricts the movement of the linkage to prevent abrupt operation or reversing.

Moreover, the feeling of the dynamic braking can be adjusted by changing the arm (13) position of damper (12).

(Reference)

[A] : Force of the damper is large.

[B] : Force of the damper is small.

- | | |
|-------------------------|-----------------------|
| (1) Neutral Spring | (8) Cruise Lock |
| (2) Trunnion Arm | (9) Cruise Lock |
| (3) Cruise Rod | (10) HST Pedal Link |
| (4) Brake Pedal | (11) Speed Change Rod |
| (5) Speed Control Pedal | (12) Damper |
| (6) Parking Plate | (13) Arm |
| (7) Cruise Arm | |

W1020319

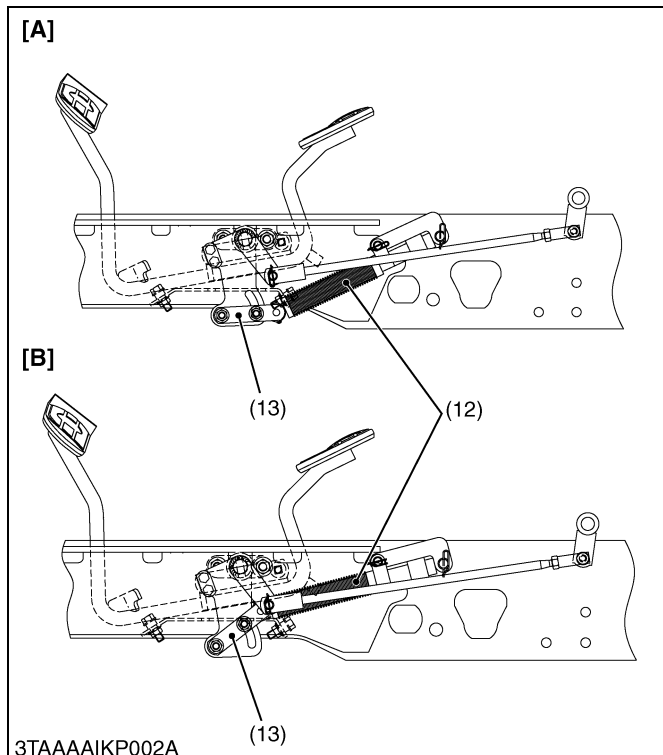

(4) Speed Set Linkage

■ Speed Set

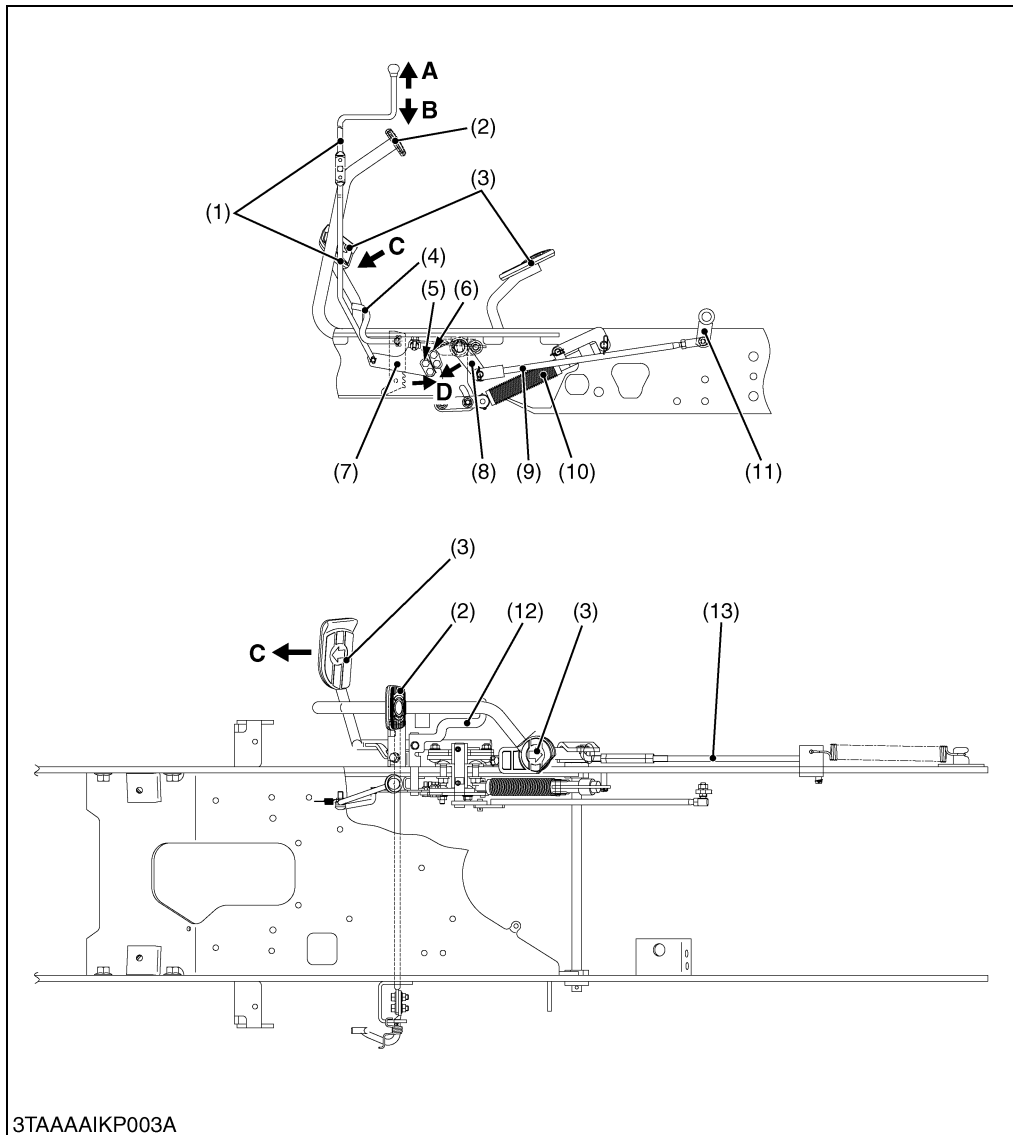

- (1) Speed Set Rod
- (2) Brake Pedal
- (3) Speed Control Pedal
- (4) Parking Brake Lock Pedal
- (5) Cruise Lock
- (6) Cruise Lock
- (7) Cruise Arm
- (8) HST Pedal Link
- (9) Speed Change Rod
- (10) Damper
- (11) Trunnion Arm
- (12) Release Plate
- (13) Brake Rod

A : Speed Set Rod "OFF"

B : Speed Set Rod "ON"

C : Speed Control Pedal "Forward"

D : Cruise Lock "Locked"

W1020771

3TAAAAIKP003A

When pushing and holding the speed set rod (1) and depressing the speed control pedal (3), the desired speed is set.

When pushing the speed set rod (1), the cruise arm (7) is rotated counter clockwise.

When depressing the speed control pedal (3) forward, the HST pedal link clockwise.

Since both the cruise lock (5) of the cruise arm (7) and the cruise lock (6) of HST pedal link (8) are locked, the speed control pedal (3) is held at a selected position.

■ When the Brake Pedal is Depressed

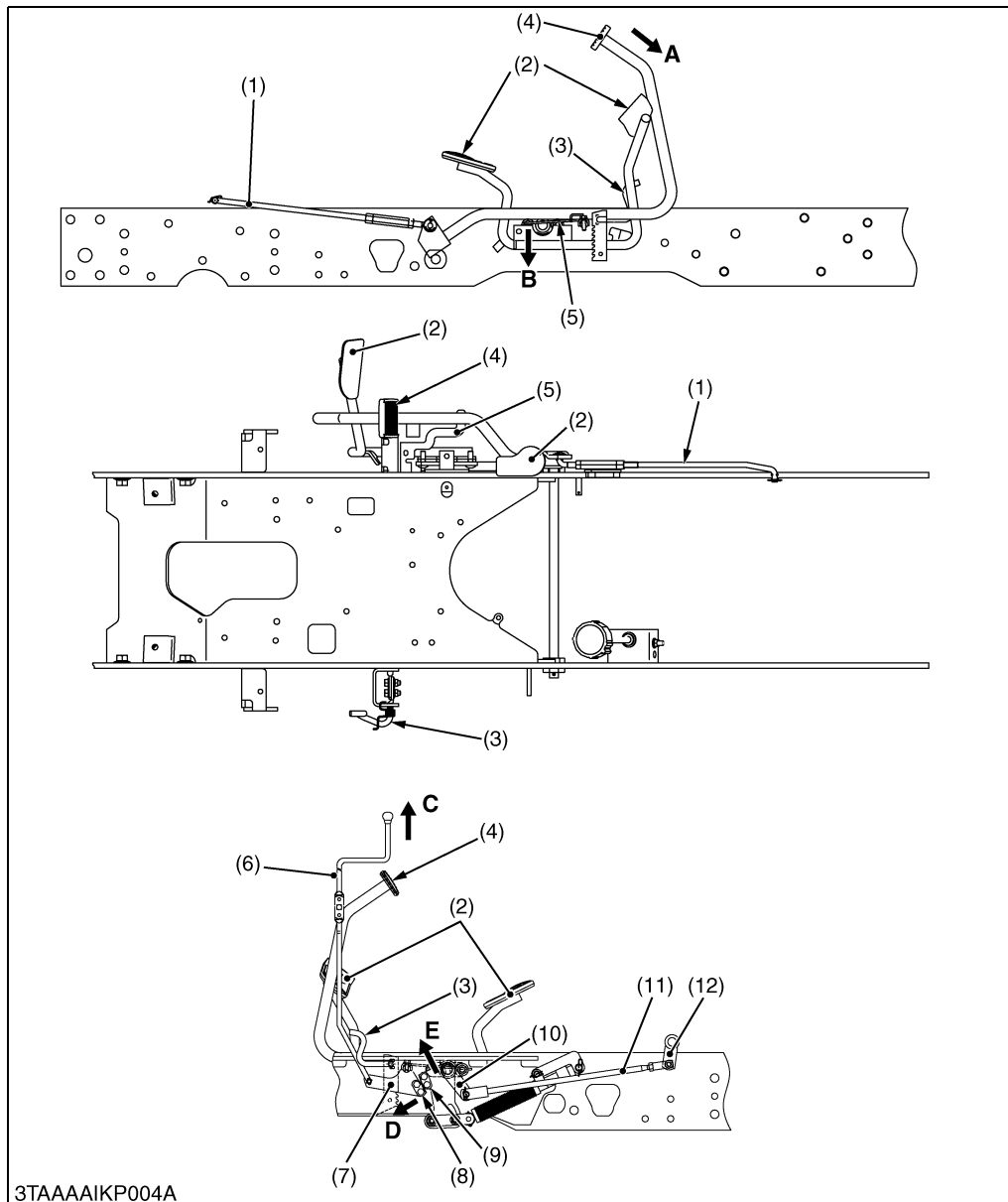

- (1) Brake Rod
- (2) Speed Control Pedal
- (3) Parking Brake Lock Pedal
- (4) Brake Pedal
- (5) Release Plate
- (6) Speed Set Rod
- (7) Cruise Arm
- (8) Cruise Lock
- (9) Cruise Lock
- (10) HST Pedal Link
- (11) Speed Change Rod
- (12) Trunnion Arm

- A** : Brake Pedal “Depressed”
- B** : Release Plate “Pushed Down”
- C** : Cruise Rod “Pushed Up”
- D** : Cruise Arm Rotates “Clockwise”
- E** : HST Pedal Link “Pushed Up”

W1022896

3TAAAIAKP004A

When the brake pedal (1) is depressed, the release plate (5) located under the brake pedal (1) is pushed down. Since the release plate (5) rotates, the HST pedal link (10) is pushed up.

The lock between the cruise lock (9) of the HST pedal link (10) and the cruise lock (8) of the cruise arm (7) is released.

The speed control pedal (2) is not held at a selected position.

Since the spring pulls the speed set rod (6) upward, the speed set rod (6) is pushed up.

[2] RANGE GEAR SHIFT SECTION

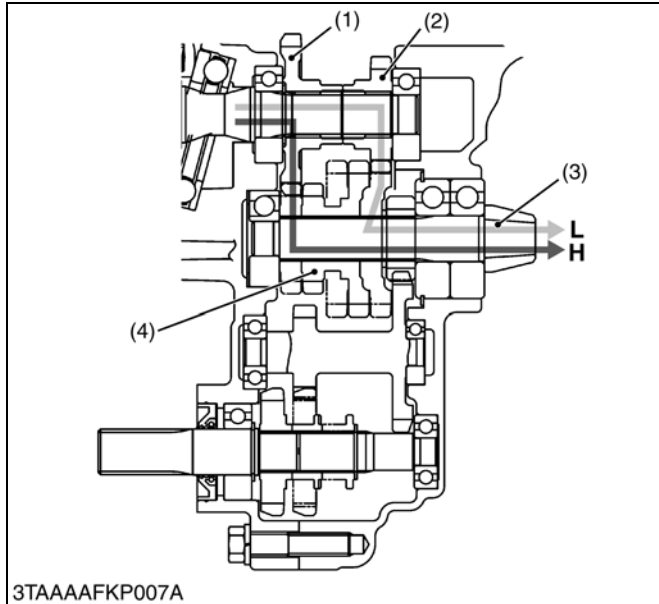

Two kinds of power flow are selected by operating the range gear shift lever to shift the 16T-24T shifter gear (4) on the spiral bevel gear shaft (3).

■ Low Range

17T Gear Shaft (2) → Shifter Gear (24T) (4) → Spiral Bevel Pinion Shaft (3).

■ High Range

25T Gear (1) → Shifter Gear (16T) (4) → Spiral Bevel Pinion Shaft (3).

- (1) 25T Gear
- (2) 17T Gear
- (3) Spiral Bevel Pinion Shaft
- (4) 16T-24T Shifter Gear

L : Low Range
H : High Range

W1014705

[3] FRONT WHEEL DRIVE SECTION

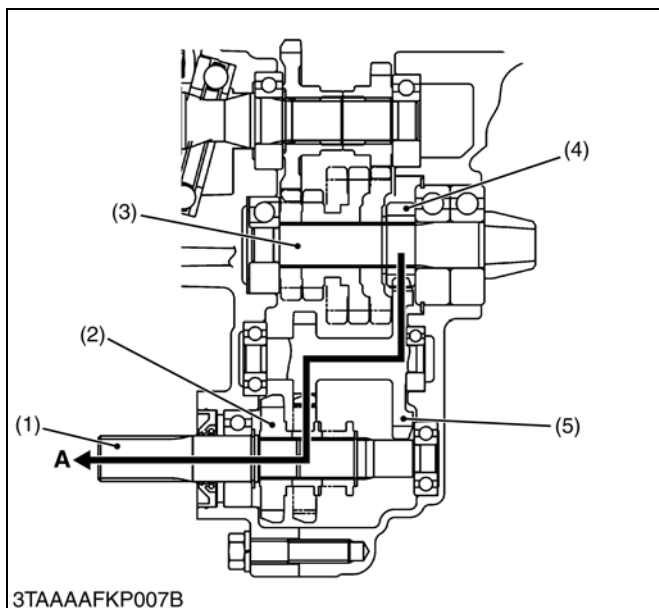

2-wheel drive or 4-wheel drive is selected by changing the position of 19T shifter gear (2) with the front wheel drive lever.

■ Front Wheel Drive “Disengaged”

When the front wheel drive lever is set to “Disengaged” position, the 19T shifter gear (2) is neutral and power is not transmitted to the front wheel drive shaft (1).

■ Front Wheel Drive “Engaged”

When the front wheel drive lever is set to “Engaged” position, the 19T shifter gear (2) slides to the right to engage with 13T-25T gear shaft (5). Therefore, the power from spiral bevel pinion shaft (3) is transmitted to the front wheel drive shaft (1) through the gears.

- (1) Front Wheel Drive Shaft
- (2) 19T Shifter Gear
- (3) Spiral Bevel Pinion Shaft
- (4) 12T Gear
- (5) 13T-25T Gear Shaft

A : Front Wheel Drive “Engaged”

W1014843

[4] DIFFERENTIAL GEAR SECTION

(1) Differential Gears

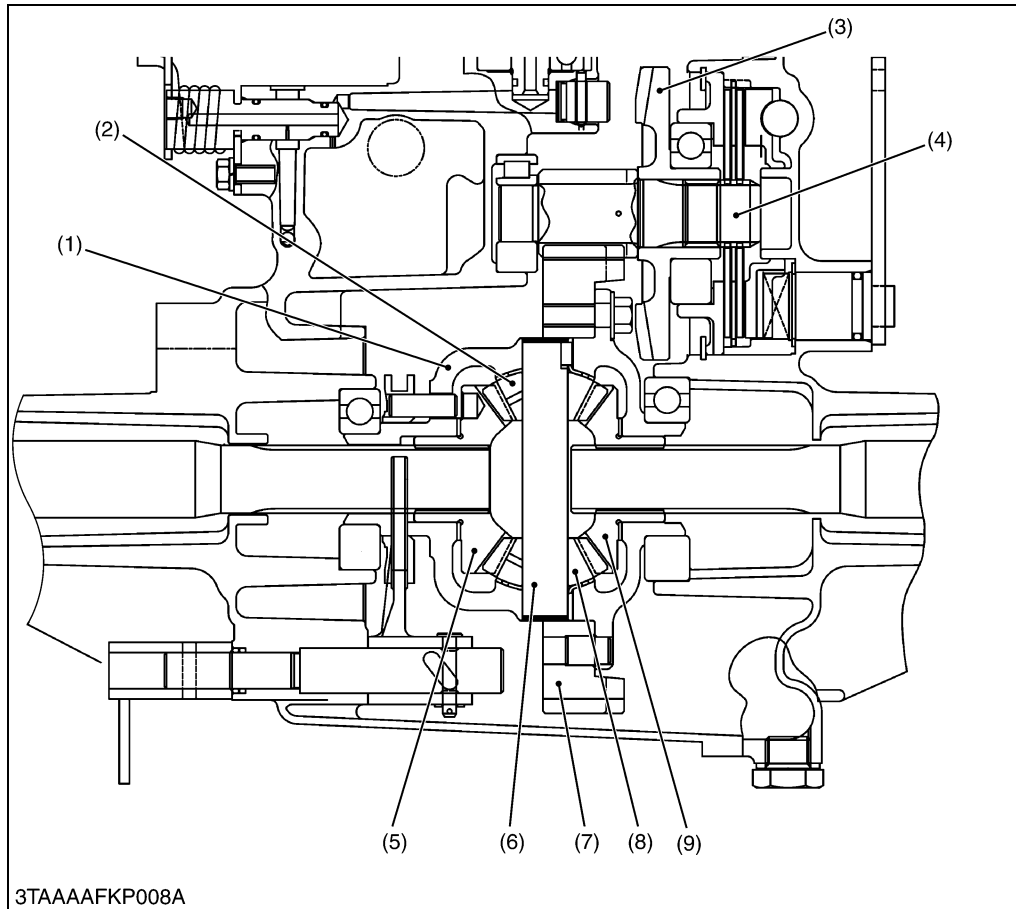

- (1) Differential Case
- (2) Differential Pinion
- (3) 37T Spiral Bevel Gear
- (4) 10T Final Gear Shaft
- (5) Differential Side Gear
- (6) Differential Pinion Shaft
- (7) 66T Final Gear
- (8) Differential Pinion
- (9) Differential Side Gear

W1018746

3TAAAFKP008A

1. During Straight Running

Rotation of the spiral bevel pinion is transmitted to the 37T spiral bevel gear (3), 10T final gear shaft (4), 66T final gear (7) and differential case (1).

When road resistance to the right and left wheels are equal, differential pinions (2), (8) and differential side gears (5), (9) all rotate as a unit. Both rear axles received equal input, and both wheels turn at the same speed, allowing the tractor to go straight ahead.

At this time, differential pinions (2), (8) do not rotate around the differential pinion shaft (6).

2. During Turning

When the tractor turns, the road resistance to the inside tire increases. In other words, if one of tires slows down, revolution difference is generated in the differential side gears (5), (9). When rotation of one differential side gear becomes lower than the other, differential pinions (2), (8) begin rotating around differential pinion shaft (6). The other differential side gear is increased in speed by the speed increment of differential pinion shaft (6). This means that rotation of one rear axle is slowed down and that of the other rear axle is increased. Thus, the tractor turn smoothly without power loss.

The combined number of revolutions of the right and left differential side gears is always twice that of the spiral bevel gear (3). When spiral bevel gear revolution is 100 min^{-1} (rpm), and if one of the differential side gears stops moving, the revolution of the other differential side gear becomes 200 min^{-1} (rpm) and if one rotates at 50 min^{-1} (rpm), the other rotates at 150 min^{-1} (rpm).

(2) Differential Lock

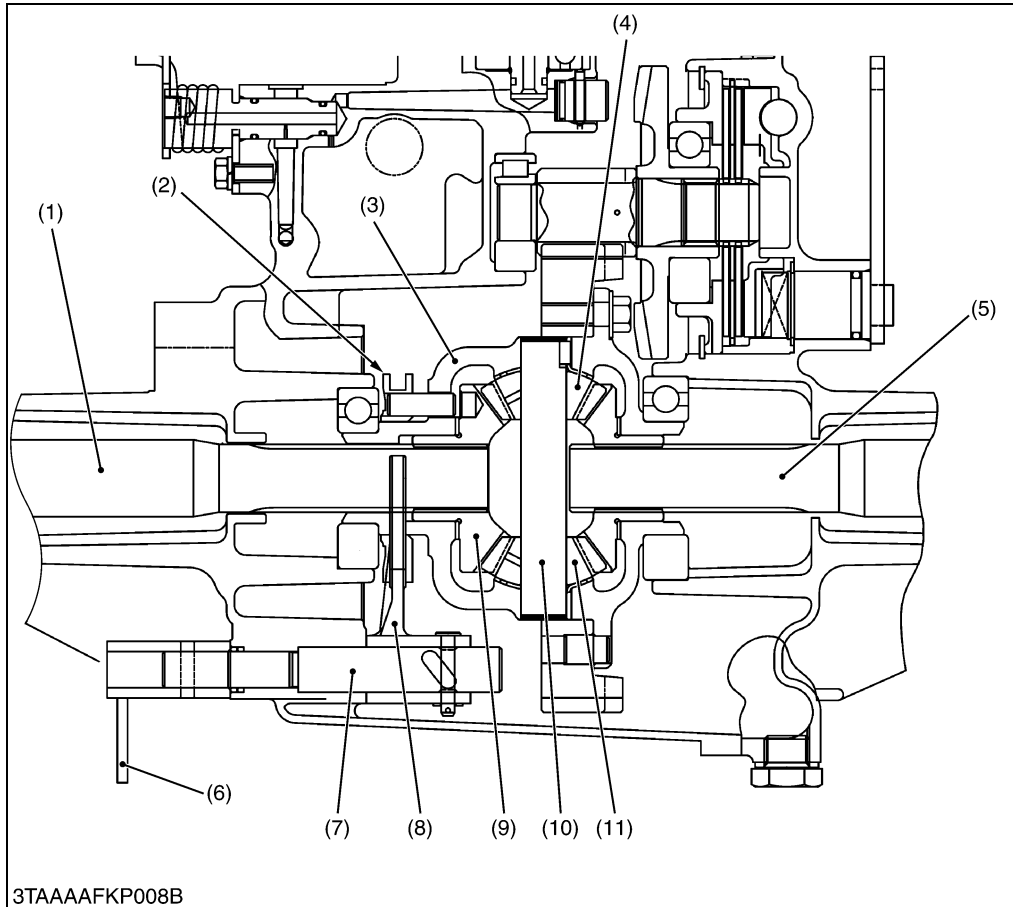

- (1) Rear Axle
- (2) Differential Lock Shifter
- (3) Differential Case
- (4) Differential Pinion
- (5) Rear Axle
- (6) Differential Lock Arm
- (7) Differential Lock Shaft
- (8) Differential Lock Shift Fork
- (9) Differential Side Gear
- (10) Differential Pinion Shaft
- (11) Differential Pinion

W1015160

When resistance to the right and left tires are greatly different due to ground conditions or type of work, the tire with less resistance slips and prevents the tractor from moving ahead. To compensate for this drawback, the differential lock restricts the differential action and causes both rear axles to rotate as a unit.

When the differential lock pedal is stepped on, it causes the differential lock arm (6) and differential lock shaft (7) to rotate, which will move the differential lock shift fork (8) and the differential lock shifter (2) toward the differential side gear (9). The pins on the differential lock shifter (2) go into the holes in the differential case (3) to cause the differential case (3), differential lock shifter (2) and differential side gear (9) to rotate as a unit.

Therefore, differential pinions (4), (11) are unable to rotate around differential pinion shaft (10) and identical revolutions are transmitted to the right and left rear axle (1), (5).

[5] BRAKE SECTION

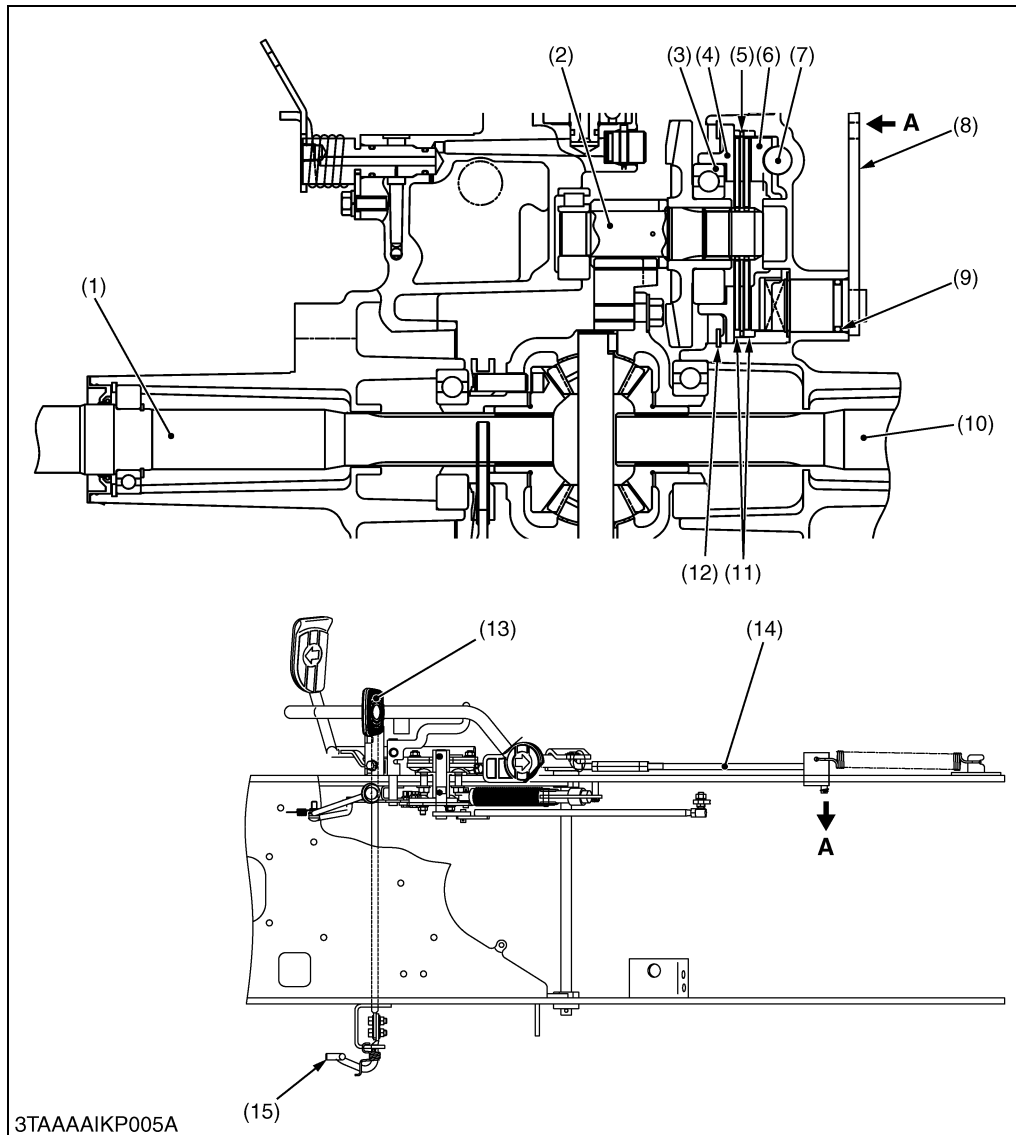

- (1) Rear Axle LH
- (2) Final Gear Shaft
- (3) Shim
- (4) Bearing Holder
- (5) Friction Plate
- (6) Actuator
- (7) Steel Ball
- (8) Cam Lever
- (9) O-ring
- (10) Rear Axle RH
- (11) Brake Disc
- (12) Internal Cir-Clip
- (13) Brake Pedal
- (14) Brake Rod
- (15) Parking Brake Lock Pedal

A : Connects with Brake Cam Lever and Brake Rod

W1019428

The mechanical wet disc brakes are used for the travelling brake. The brake is operated by the brake pedal (13) through the mechanical linkages and provide stable braking and require little adjustment.

The brake body is incorporated in the transmission case and axle cover filled with transmission oil.

For greater braking force, four brake discs (11) are provided at the brake shaft, and the friction plates (5) fixed to the transmission case is arranged between the brake discs (11).

■ Travelling Brake

When the brake pedal (13) is depressed, the brake rod pulls the brake cam lever (8).

Therefore, the cam plates also moves and rides on the steel balls set in the grooves of the transmission case to press the brake disc, the final gear shaft is braked by the frictional force generated by the cam plate and brake disc.

■ Parking Brake

When the parking brake is applied, the brake pedal (13) is locked by the parking brake lock pedal (15).

3. PTO SYSTEM

[1] PTO CLUTCH AND VALVE

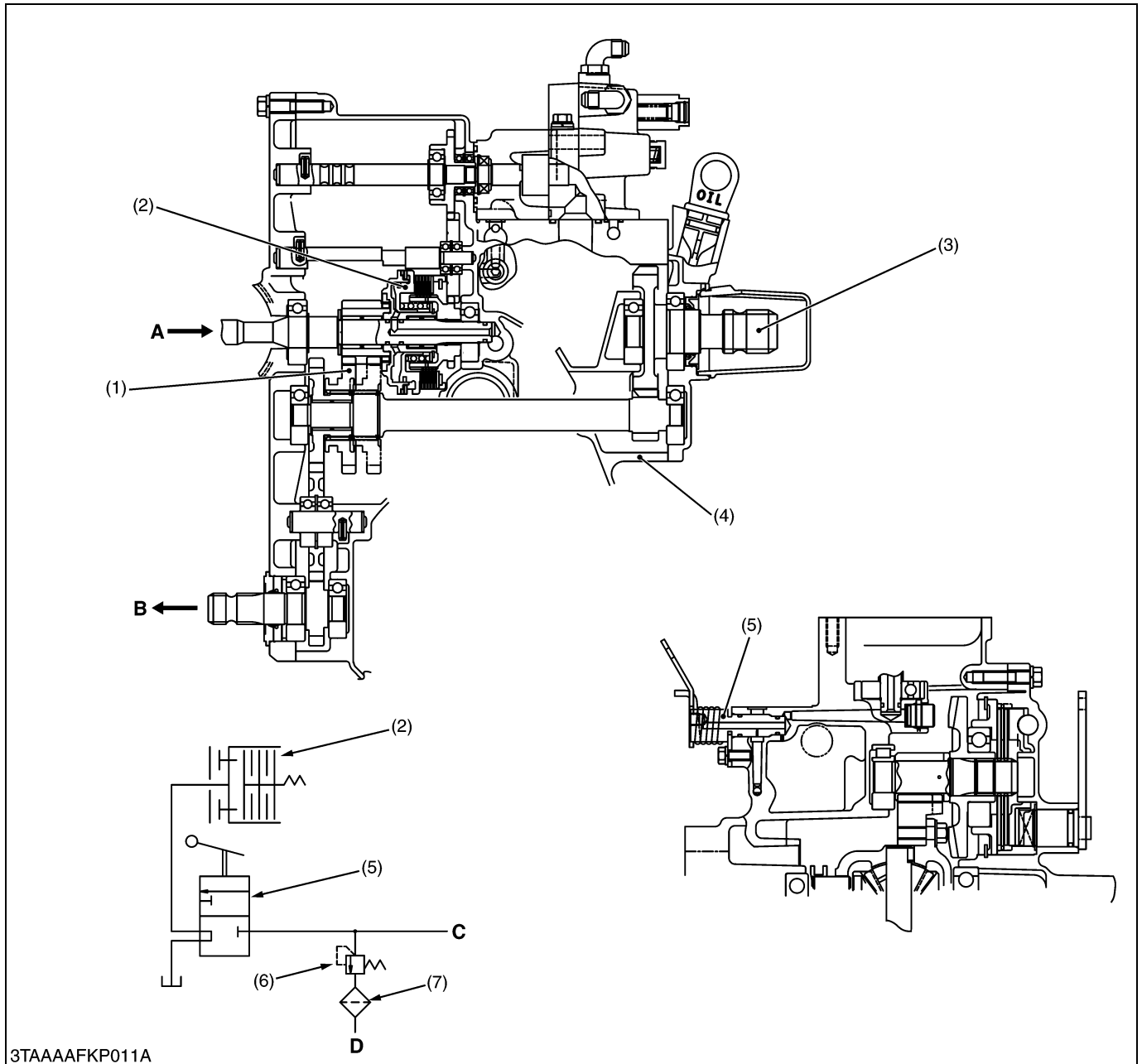

3TAAAFKP011A

- | | | | |
|-----------------------|-----------------------------|--------------------------------|---|
| (1) PTO Select Gear | (5) PTO Clutch Valve | A : From HST Pump Shaft | C : From Power Steering Controller |
| (2) PTO Clutch Pack | (6) PTO Clutch Relief Valve | B : To Mid-PTO | D : To Hydrostatic Transmission |
| (3) Rear PTO Shaft | (7) Oil Filter Cartridge | | |
| (4) Transmission Case | | | |

The BX 50 series equipped with hydraulic independent PTO clutch (wet multi-plates type). Therefore, the engine power engages or disengages to the PTO shafts without stopping the tractor movement.

The PTO clutch pack (2) has four clutch discs, four drive plates, pressure plate, clutch piston and so on.

The clutch piston is actuated by hydraulic oil flow from the power steering controller.

The PTO clutch valve (5) controls the hydraulic oil flow from power steering controller to the PTO clutch pack (2) by operating the PTO clutch lever through the linkage.

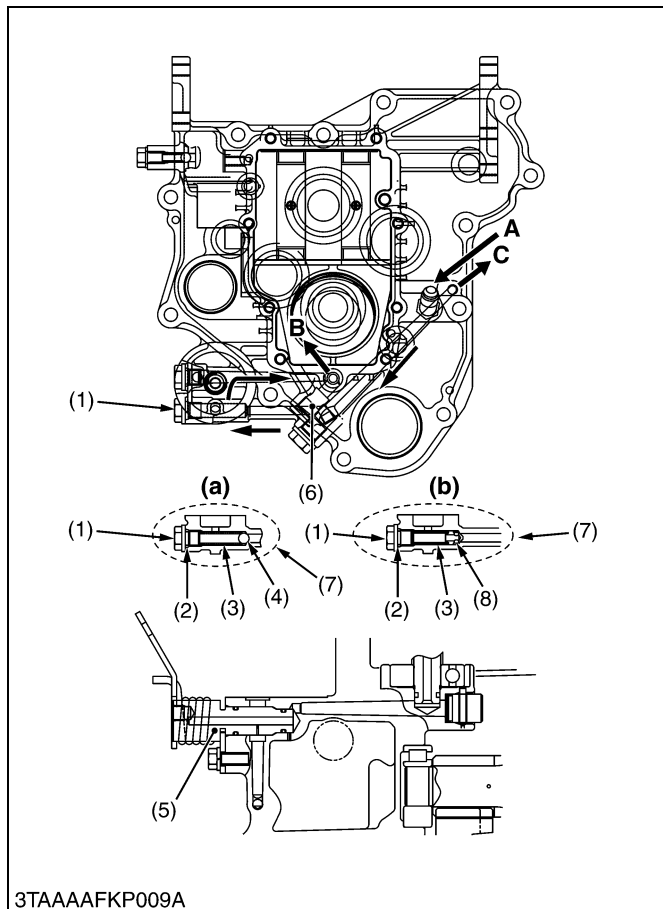

3TAAAFKP009A

■ PTO Clutch Relief Valve

The PTO clutch relief valve is provided to control the PTO operating pressure. When the oil pressure exceed the relief valve setting pressure, relief valve opens and the oil flows into PTO clutch and hydrostatic transmission.

(Reference)

- Relief valve setting pressure : 490 kPa
5.0 kgf/cm²
71.2 psi

- (1) Plug
- (2) O-ring
- (3) Spring
- (4) Steel Ball
- (5) PTO Clutch Valve
- (6) HST Charge Relief Valve
- (7) PTO Clutch Relief Valve
- (8) Poppet

- A : From Power Steering Controller**
- B : To Hydrostatic Transmission**
- C : To PTO Clutch Valve**

- (a) Old Type**
- (b) New Type**

W1015382

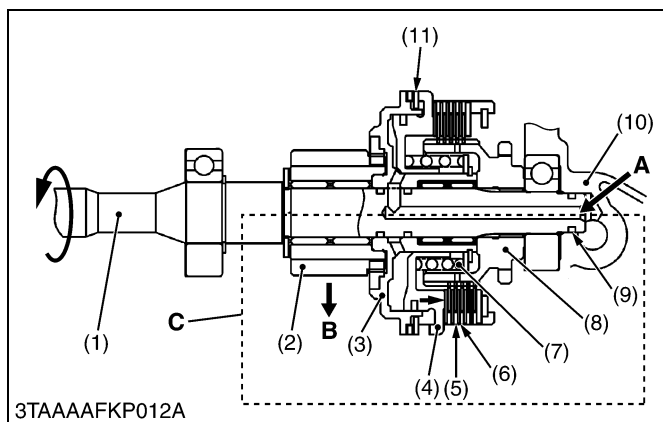

3TAAAFKP012A

■ PTO Clutch "Engaged"

The oil from power steering controller flows into the PTO clutch valve.

When the PTO clutch lever is set at the "Engaged" position, the PTO clutch valve rotates. Oil flows from the oil line through transmission case to the PTO clutch pack.

Oil entering the clutch pack pushes the clutch piston (4) to engage the clutch pack. Power is transmitted from the HST pump shaft (1) through the PTO clutch to the clutch gear (2) and the PTO shafts.

- (1) HST Pump Shaft
- (2) Clutch Gear
- (3) Clutch Case
- (4) Clutch Piston
- (5) Clutch Plate
- (6) Clutch Disc
- (7) Spring
- (8) Spline Boss

- (9) O-ring
- (10) Transaxle Case
- (11) Brake Disc

- A : From PTO Clutch Valve**
- B : Power to PTO Shaft**
- C : PTO Clutch "Engaged"**

W1015610

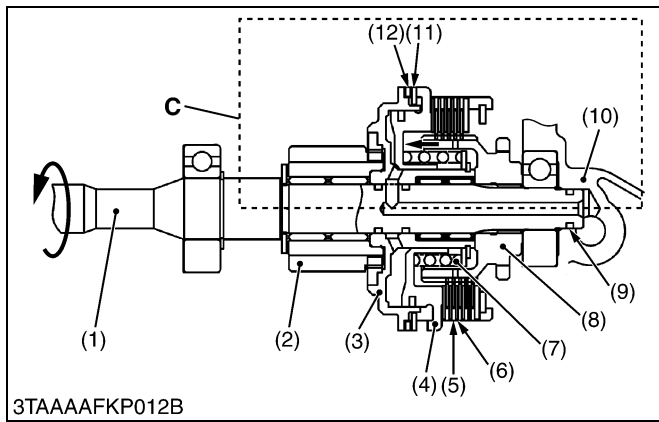

■ PTO Clutch “Disengaged”

When the PTO clutch lever is set at the “Disengaged” position, the PTO clutch valve closes the oil passage to the PTO clutch pack. The oil in the PTO clutch pack drain into the transaxle case (10). Thus the clutch piston (4) is pushed back by the spring (7).

When the clutch piston (4) is pushed back by the spring (7), the brake plate (11) is also moved to contract the brake disc (12) so as to stop the rotation and drag of the PTO shafts.

- | | |
|--------------------|---------------------|
| (1) HST Pump Shaft | (9) O-ring |
| (2) Clutch Gear | (10) Transaxle Case |
| (3) Clutch Case | (11) Brake Plate |
| (4) Clutch Piston | (12) Brake Disc |
| (5) Clutch Plate | |
| (6) Clutch Disc | |
| (7) Spring | |
| (8) Spline Boss | |

C : PTO Clutch “Disengaged”

W1015793

[2] MID AND REAR PTO SECTION

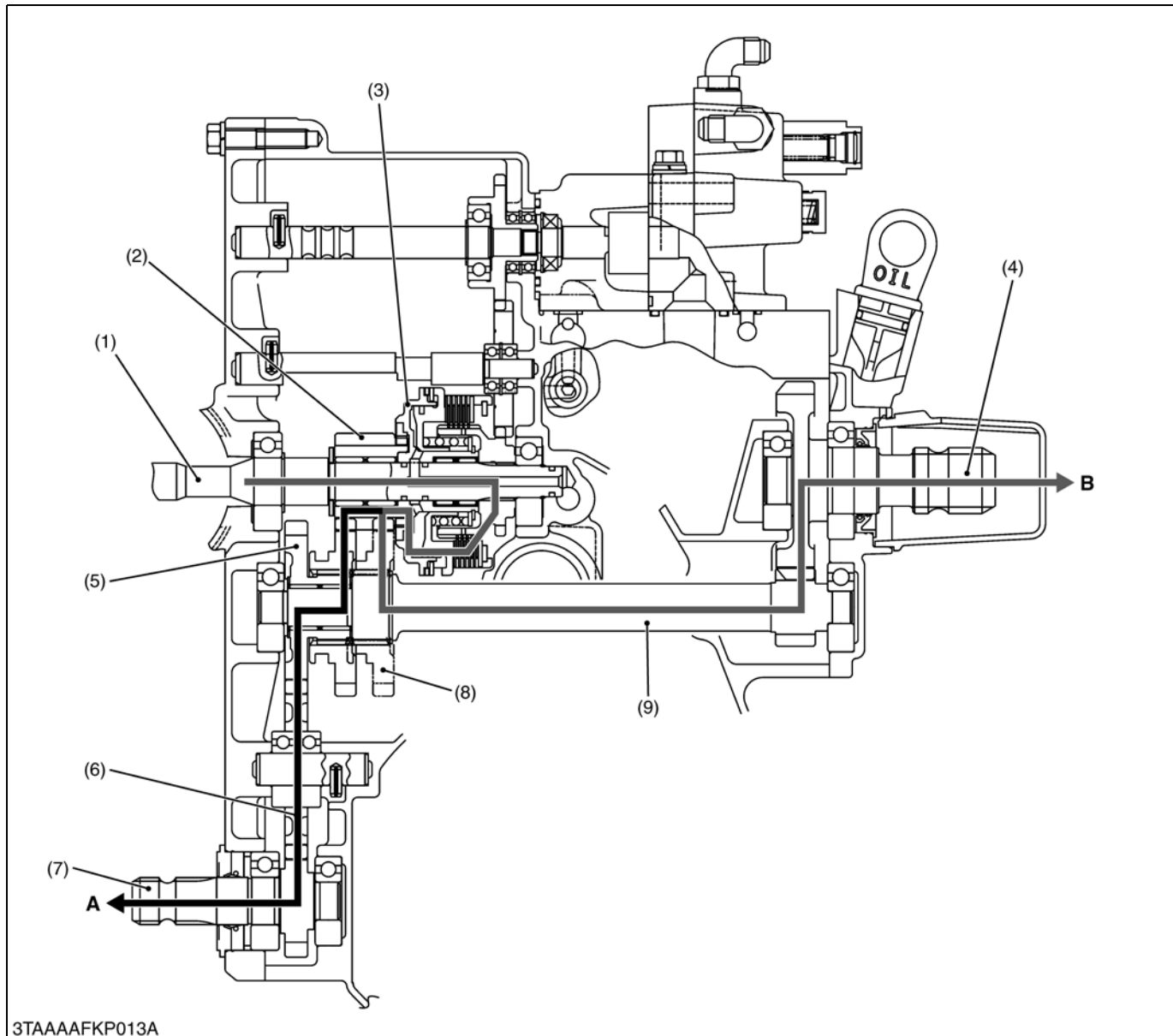

- | | | | |
|---------------------|----------------------|---------------------------|-------------------------|
| (1) HST Pump Shaft | (4) Rear PTO Shaft | (6) 24T Mid PTO Idle Gear | (8) 28T PTO Select Gear |
| (2) 12T Clutch Gear | (5) 23T Mid PTO Gear | (7) Mid-PTO Shaft | (9) 11T Gear Shaft |
| (3) PTO Clutch Pack | | | |

Three kinds of power flow are selected by operating the PTO select lever to shift the PTO select gear (8) on the 11T gear shaft (9).

■ Mid-PTO Position (A)

PTO Clutch Pack (3) → 12T Gear Clutch (2) → PTO Select Gear (8) → 23T Mid PTO Gear (5) → 24T Mid PTO Idle Gear (6) → Mid-PTO Shaft (7).

■ Rear PTO Position (B)

PTO Clutch Pack (3) → 12T Gear Clutch (2) → PTO Select Gear (8) → 11T Gear Shaft (9) → Rear PTO Shaft (4).

■ Mid and Rear PTO Position

A and B at the same time.

4. OTHERS

[1] HYDRAULIC PUMP DRIVE GEAR SECTION

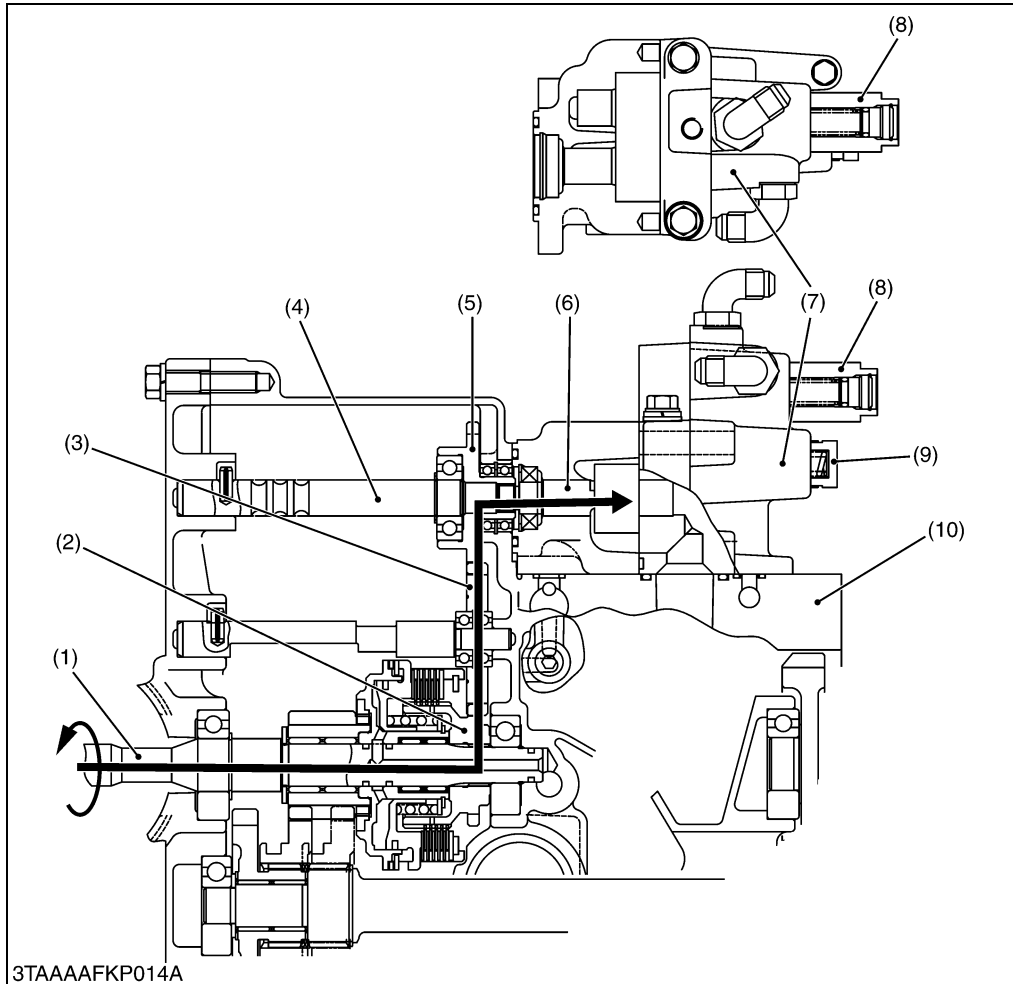

- (1) HST Pump Shaft
- (2) Spline Boss
- (3) Idle Gear
- (4) Hydraulic Pump Drive Gear Shaft
- (5) Hydraulic Pump Drive Gear
- (6) Hydraulic Pump Drive Gear Shaft
- (7) Hydraulic Pump
- (8) Flow Priority Valve
- (9) Relief Valve (3P Hitch)
- (10) Transmission Case

W1016433

3TAAAFKP014A

The hydraulic pump (7) is mounted to the transmission case (10) and driven by the hydraulic pump drive gear (5). The spline boss (2) mounted on the HST pump shaft drives the hydraulic pump drive gear (5) mounted on the hydraulic pump drive gear shaft (4) through the idle gear (3).

SERVICING

CONTENTS

1. TROUBLESHOOTING	2-S1
2. SERVICING SPECIFICATIONS	2-S5
3. TIGHTENING TORQUES	2-S7
4. CHECKING, DISASSEMBLING AND SERVICING.....	2-S8
[1] CHECKING AND ADJUSTING	2-S8
[2] PREPARATION	2-S16
(1) Separating Transaxle.....	2-S16
[3] DISASSEMBLING AND ASSEMBLING.....	2-S24
(1) Hydrostatic Transmission.....	2-S24
(2) Hydraulic Cylinder.....	2-S30
(3) Transaxle Shafts	2-S31
(4) Assembling Shafts	2-S39
[4] SERVICING	2-S41
(1) Hydrostatic Transmission.....	2-S41
(2) Transaxle Case.....	2-S43

1. TROUBLESHOOTING

HYDROSTATIC TRANSMISSION

Symptom	Probable Cause	Solution	Reference Page	
System Will Not Operate in Either Direction	Oil level is low	Check oil level or fill oil to proper level	G-24	
	Speed control pedal linkage defective	Repair linkage	2-S21	
	Charge pressure is too low		Solution order 1. Replace oil filter cartridge	G-24
			2. Check charge pressure	2-S12
			3. Inspect or flush charge relief valve	2-S41
	Check and high pressure relief valve does not move smoothly	Inspect or replace check and high pressure relief valve	2-S41	
	Component parts defective	Replace hydrostatic transmission assembly	2-S25	
Vibration and Noise	Oil level is too low	Check oil level or fill oil to proper level	G-24	
	Speed control pedal linkage defective	Repair linkage	2-S21	
	Charge pressure is too low		Solution order 1. Replace oil filter cartridge	G-24
			2. Check charge pressure	2-S12
			3. Inspect or flush charge relief valve	2-S41
	Check and high pressure relief valve does not move smoothly	Inspect or replace check and high pressure relief valve	2-S41	
	Component part is defective	Replace hydrostatic transmission assembly	2-S25	

W1022927

HYDROSTATIC TRANSMISSION (Continued)

Symptom	Probable Cause	Solution	Reference Page
Loss of Power	Oil level is low	Check oil level or fill oil to proper level	G-24
	Speed control pedal linkage defective	Repair linkage	2-S21, S23
	Charge pressure is too low	1. Replace oil filter cartridge	G-24
		2. Check charge pressure	2-S12
		3. Inspect or flush charge relief valve	2-S41
	Check and high pressure relief valve does not move smoothly	Inspect or replace check and high pressure relief valve	2-S41
Component parts defective	Replace hydrostatic transmission assembly	2-S41	
Transmission Oil Over Heats	Low transmission oil level	Fill transmission oil level up to proper level	G-24
	Radiator net clogged	Clean radiator net	–
	Excessive machine load	Reduce machine load	–
	Improper charge pressure	1. Check high relief pressure	2-S12
		2. Replace transmission oil filter cartridge	G-24
		3. Replace check and high pressure relief valve	2-S41
4. Inspect and replace charge relief valve		2-S41	
Machine Will Not Stop in Neutral Position	Speed control linkage is out of adjustment or sticking	Repair or replace linkage	2-S21, S23
		Adjust neutral position	2-S10
System Operates in One Direction Only	Speed control linkage defective	Repair or replace linkage	2-S21, S23
	Check and high pressure relief valve defective	Replace check and high pressure relief valve	2-S41

W1026435

TRAVELLING GEAR SHIFT SECTION

Symptom	Probable Cause	Solution	Reference Page
Noise from Transmission	Transmission oil insufficient	Refill	2-S16
	Gear worn or broken	Replace	–
	Bearings worn	Replace	–
Gear Slip Out of Mesh	Shift fork spring tension insufficient	Replace	2-S39, S40
	Shift fork or shifter worn	Replace	2-S39, S40
	Shift fork bent	Replace	2-S39, S40

W1013580

DIFFERENTIAL GEAR SECTION

Excessive or Unusual Noise at All Time	Improper backlash between spiral bevel pinion and bevel gear	Adjust	2-S46
	Improper backlash between differential pinion and differential side gear	Adjust	2-S45
	Bearing worn	Replace	–
	Insufficient or improper type of transmission fluid used	Replenish or change	G-7, 2-S16
Noise while Turning	Differential pinions or differential side gears worn or damaged	Replace	2-S35, 2-S40
	Differential lock binding (does not disengaged)	Replace	2-S36
	Bearing worn	Replace	–
Differential Lock Can Not Be Set	Differential lock shift fork damaged	Replace	2-S36
	Differential lock shifter mounting pin damaged	Replace	2-S36
	Differential lock pin damaged	Replace	2-S36
Differential Lock Pedal Does Not Return	Differential lock pedal return spring weaken or damaged	Replace	2-S22
	Differential lock fork shaft rusted	Repair	2-S36

W1013718

BRAKE SECTION

Brake Drags	Brake pedal free travel too small	Adjust	G-22
	Ball holes of actuator for uneven wear	Replace	2-S47
	Brake pedal return spring weaken or broken	Replace	2-S22
	Brake cam rusted	Repair	2-S37
Poor Braking Force	Brake pedal free travel excessive	Adjust	G-22
	Brake disc worn	Replace	2-S37
	Actuator warped	Replace	2-S37
	Brake cam or lever damaged	Replace	2-S37
	Transmission fluid improper	Change	2-S16

W1010878

PTO SECTION

Symptom	Probable Cause	Solution	Reference Page
PTO Clutch Slip	Operating pressure is low	Check	2-S15
	PTO clutch valve malfunctioning	Repair or replace	2-S24
	Clutch disc or drive plate excessively worn	Replace	2-S38
	Deformation of clutch piston	Replace	2-S38
PTO Shaft Does Not Rotate	PTO clutch malfunctioning	Repair or replace	2-S38
PTO Clutch Operating Pressure is Low	Transmission oil improper or insufficient	Replenish or change	2-S16
	Relief valve malfunctioning	Check or replace	2-M16
PTO Clutch Drags	Brake plate excessive worn	Replace	2-S38
	Clutch spring weaken or broken	Replace	2-S38
	Deformation of pressure plate or steel plate	Replace	2-S38

W1011002

2. SERVICING SPECIFICATIONS

Item		Factory Specification	Allowable Limit
Charge Relief Valve [Oil temperature at 50 °C, 122 °F]	Setting Pressure	0.55 to 0.75 MPa 5.6 to 7.7 kgf/cm ² 80 to 100 psi	–
High Pressure Relief Valve (Forward and Reverse) [Oil temperature at 50 °C, 122 °F]	Setting Pressure	20.1 to 21.1 MPa 205 to 215 kgf/cm ² 2920 to 3060 psi	
PTO Clutch	Operating Pressure	1.0 to 1.3 MPa 11 to 13 kgf/cm ² 150 to 180 psi	
PTO Clutch Disc	Thickness	1.50 to 1.70 mm 0.0591 to 0.0669 in.	1.35 mm 0.0531 in.
Separate Plate	Thickness	0.9450 to 1.055 mm 0.03721 to 0.04153 in.	0.80 mm 0.031 in.
Back Plate	Thickness	1.9 to 2.1 mm 0.075 to 0.082 in.	1.85 mm 0.0728 in.
Clutch Piston	Flatness	–	0.15 mm 0.0059 in.
Pressure Plate and Steel Plate	Flatness	–	0.20 mm 0.0079 in.
Clutch Spring	Free Length	38.5 mm 1.52 in.	34.5 mm 1.36 in.
PTO Brake Disc	Thickness	2.90 to 3.10 mm 0.115 to 0.122 in.	2.70 mm 0.11 in.
PTO Brake Plate	Thickness	1.9 to 2.1 mm 0.075 to 0.082 in.	1.85 mm 0.073 in.
Differential Case to Differential Side Gear	Clearance	0.0500 to 0.151 mm 0.00197 to 0.00594 in.	0.30 mm 0.012 in.
Differential Case	I.D.	38.000 to 38.062 mm 1.4961 to 1.4985 in.	–
Differential Side Gear	O.D.	37.911 to 37.950 mm 1.4926 to 1.4940 in.	–
Differential Pinion Shaft to Differential Pinion	Clearance	0.0800 to 0.122 mm 0.00315 to 0.00480 in.	0.30 mm 0.012 in.
Differential Pinion	I.D.	20.060 to 20.081 mm 0.78977 to 0.79059 in.	–
Differential Pinion Shaft	O.D.	19.959 to 19.980 mm 0.78579 to 0.78661 in.	–

W1013874

(Continued)

Item		Factory Specification	Allowable Limit
Differential Pinion to Differential Side Gear	Backlash	0.15 to 0.30 mm 0.0059 to 0.011 in.	0.40 mm 0.016 in.
Spiral Bevel Pinion Shaft to Spiral Bevel Gear	Backlash	0.10 to 0.30 mm 0.0040 to 0.011 in.	–
Actuator and Bearing Holder	Flatness	–	0.30 mm 0.012 in.
Cam Plate and Ball	Height	22.89 to 22.99 mm 0.9012 to 0.9051 in.	22.40 mm 0.8819 in.
Brake Disc	Thickness	3.30 to 3.50 mm 0.130 to 0.137 in.	3.0 mm 0.12 in.
Friction Plate	Thickness	1.92 to 2.08 mm 0.0756 to 0.0818 in.	1.52 mm 0.0598 in.

W1033005

3. TIGHTENING TORQUES

Tightening torques of screws, bolts and nuts on the table below are especially specified.
 (For general use screws, bolts and nuts : See page G-9.)

Item	N·m	kgf·m	lbf·ft
Charge relief valve checking plug (R 1/4)	30 to 44	3.0 to 4.5	22 to 32
Hexagon socket head plug (R 1/4)	30 to 44	3.0 to 4.5	22 to 32
Check and high pressure valve screw	25 to 29	2.5 to 3.0	18 to 21
PTO clutch operating pressure plug (R 1/8)	13 to 21	1.3 to 2.2	9.4 to 15
ROPS mounting nut	124 to 147	12.6 to 15.0	91.2 to 108
Fuel tank stay mounting bolt and nut	48 to 55	4.9 to 5.7	36 to 41
Fender bracket mounting bolt and nut	124 to 147	12.6 to 15.0	91.2 to 108
Rear wheel mounting screw	109 to 129	11.1 to 13.2	80.3 to 95.4
Hitch plate mounting bolt and nut	124 to 147	12.6 to 15.0	91.2 to 108
Transaxle assembly mounting screw (M12)	63 to 72	6.4 to 7.4	47 to 53
Transaxle assembly mounting screw (M14)	124 to 147	12.6 to 15.0	91.2 to 108
Rear coupling mounting screw (M8)	24 to 27	2.4 to 2.8	18 to 20
Front coupling mounting screw (M8)	24 to 27	2.4 to 2.8	18 to 20
HST fan mounting screw (M8)	9.8 to 11	1.0 to 1.2	7.3 to 8.6
Hydraulic control lever mounting bolt and nut	18 to 20	1.8 to 2.1	13 to 15
HST front cover mounting bolt and nut	18 to 20	1.8 to 2.1	13 to 15
Check and High pressure relief valve plug	59 to 78	6.0 to 8.0	44 to 57
Hydraulic cylinder mounting screw	40 to 44	4.0 to 4.5	29 to 32
Transaxle case front cover mounting bolt (M8)	30 to 34	3.0 to 3.5	22 to 25
Hydraulic pump assembly mounting bolt (M6)	7.9 to 8.8	0.80 to 0.90	5.8 to 6.5
Hydraulic pump assembly mounting bolt (M8)	18 to 20	1.8 to 2.1	13 to 15
Rear PTO cover mounting bolt (M8)	18 to 20	1.8 to 2.1	13 to 15
Rear axle case (RH) mounting bolt (M8)	18 to 20	1.8 to 2.1	13 to 15
66T final gear mounting screw	61 to 70	6.2 to 7.2	45 to 52

W1012736

4. CHECKING, DISASSEMBLING AND SERVICING

[1] CHECKING AND ADJUSTING

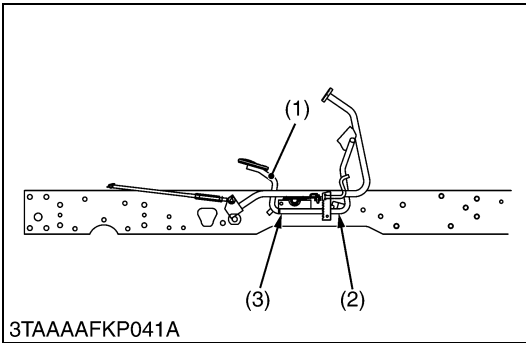

3TAAAAFKP041A

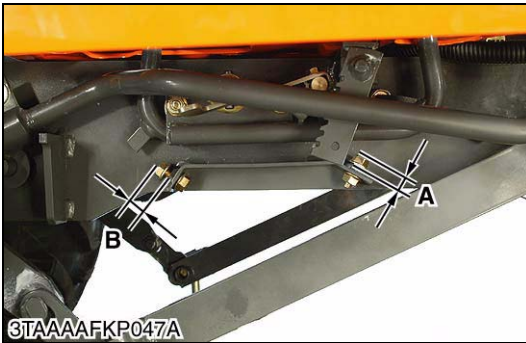

3TAAAAFKP047A



3TAAAAFKP030A



3TAAAAFKP029A

Adjusting Maximum Speed

■ Forward

1. Depress the speed control pedal (1) all the way and lengthen the stopper bolt (2) until it touches the speed control pedal (2).
2. Adjust the stopper bolt (2) length **A** to 17.0 mm (0.669 in.) and lock it securely.

■ Reverse

1. Adjust the stopper bolt (3) length **B** to 17.5 mm (0.689 in.) and lock it securely.

(Reference)

Stopper bolt length	Reference	Forward	17.0 mm 0.669 in.
		Reverse	17.5 mm 0.689 in.

Maximum speed	Reference	Forward	13.0 to 14.0 km/h 8.08 to 8.69 mph
		Reverse	10.0 to 11.0 km/h 6.22 to 6.83 mph

- (1) Speed Control Pedal
- (2) Stopper Bolt (Forward)
- (3) Stopper Bolt (Reverse)

- A : Stopper Bolt Length (Forward)**
- B : Stopper Bolt Length (Reverse)**

W1012590



Preparation before HST Adjustment

⚠ CAUTION

- **Park the machine on a firm and level ground.**
- 1. Place the wooden blocks at the front and the rear side of the wheels not to move the tractor.
- 2. Lift up the rear wheels (1) safely by the rigid jacks.
- 3. Shift the front wheel drive lever (2) to “OFF” position (A).
- 4. Remove the rear right wheel from the tractor.

- (1) Rear Wheel
 - (2) Front Wheel Drive Lever
 - (3) Neutral Adjuster
 - (4) Lock Screw
- (A) “OFF” Position

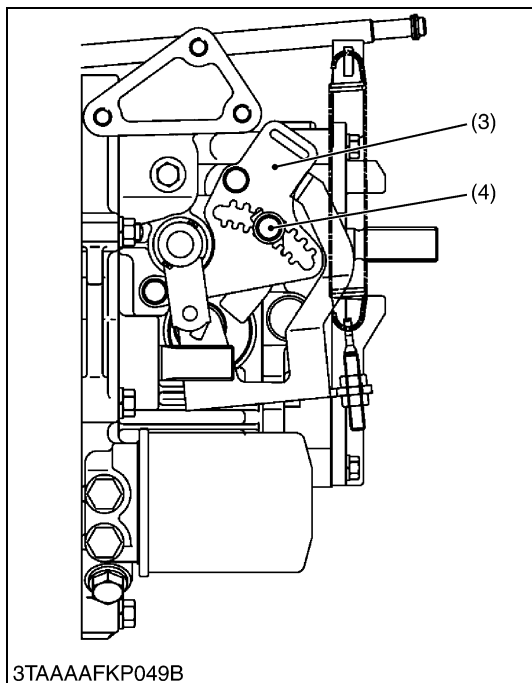
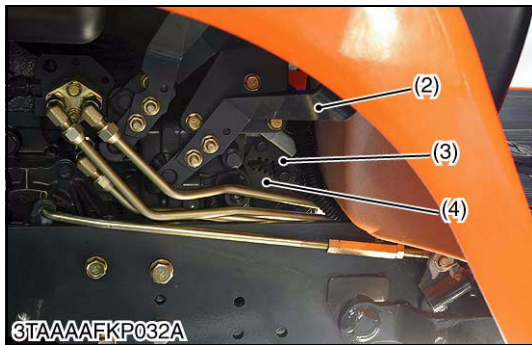
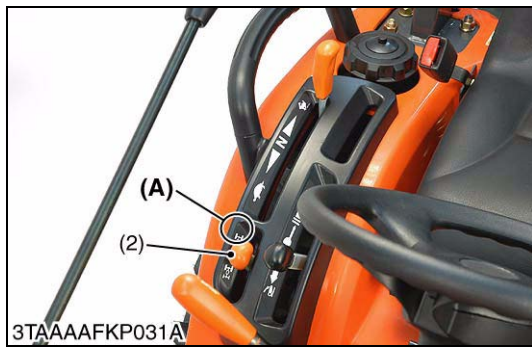

W1047776

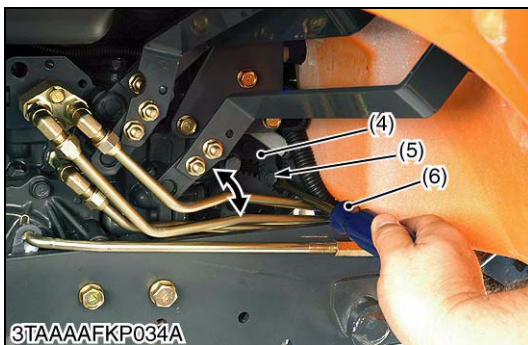
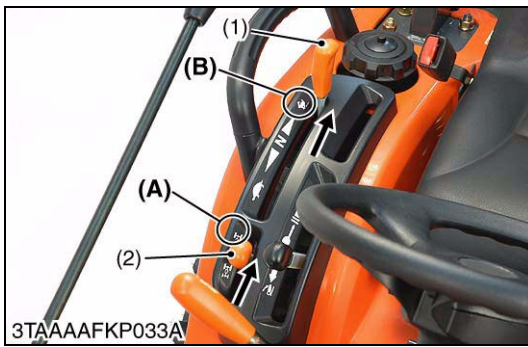

Adjustment of HST Neutral Position

1. Start the engine.
2. Keep the engine at the maximum revolution.
3. Shift the range shift lever (1) to “Hi” position (B).
4. Loosen the locking screw (5).

■ NOTE

- When adjusting the HST neutral position, loosen the locking screw approximately 2 turns counterclockwise not to drop the nut inside.
- Make sure 4WD lever is set to 2WD before making adjustment.

(Forward to Neutral Position)

5. Depress the speed control pedal (3) to “Forward” speed position, and release the foot from the speed control pedal (3). Check that the rear axle (or the wheel) stops rotating.
If the rear axle (or the wheel) does not stop rotating, move the position of the locking screw (5) to the machine front side to stop rotating.

(Reverse to Neutral Position)

6. Depress the speed control pedal (3) to “Reverse” speed position, and release the foot from the speed control pedal (3). Check the rear axle (or the wheel) stops rotating. If the rear axle (or the wheel) does not stop rotating, adjust the locking screw (5) to stop rotating.
7. After adjusting the neutral position, tighten the lock screw (5) securely.

- (1) Range Gear Shift Lever
- (2) Front Wheel Drive
- (3) Speed Control Pedal
- (4) Neutral Adjust Lever
- (5) Locking Screw
- (6) Screw Driver

- (A) 4WD “OFF” Position
- (B) “Hi” Position
- (C) FORWARD
- (D) REVERSE

W1012819

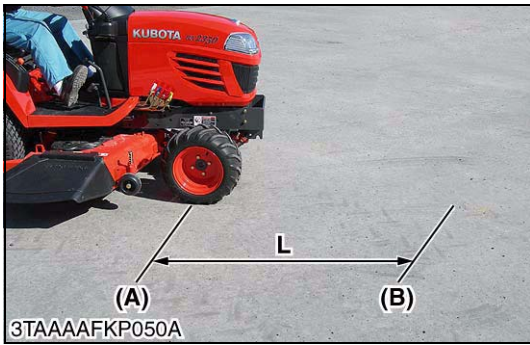

3TAAAFKP050A

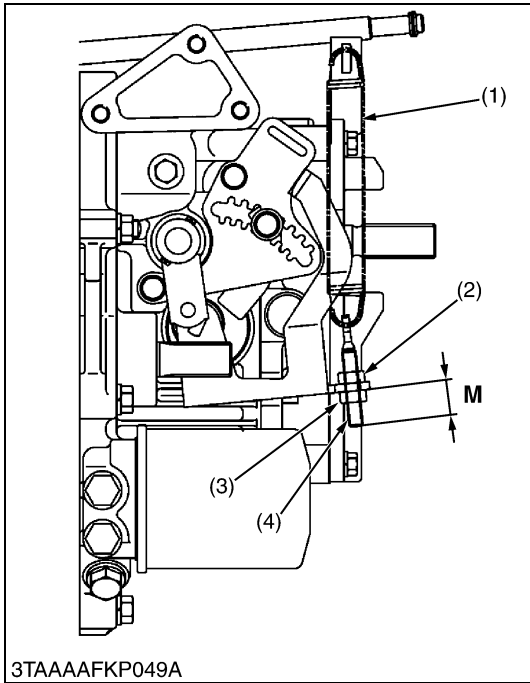

3TAAAFKP049A

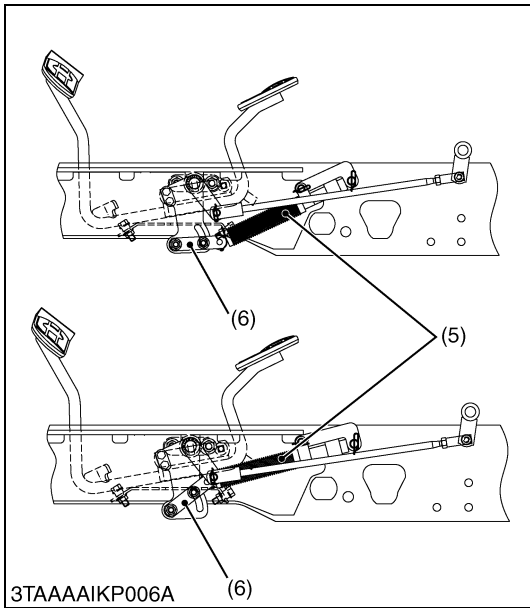

3TAAAIKP006A

Checking and Adjusting HST Neutral Spring (for Dynamic Braking)

⚠ WARNING

- Do not operate if tractor move on level ground with foot off speed control pedal.
- If tractor moves on level ground with foot off the pedal, or, if the pedal is too slow in returning to “Neutral” position when removing the foot from the pedal, adjust the HST neutral spring.

The HST neutral spring located under the front right side of the fender can adjust returning speed of speed control pedal.

Since the HST neutral spring tension is weakened, the HST tension should be checked and adjusted every 100 hours.

1. Checking the HST neutral spring tension : Dynamic braking
 - Start the engine and hold the maximum engine speeds.
 - Operate the machine on the concrete level ground.
 - Shift the range gear shift lever to “High” position.
 - Depress the speed control pedal to “Forward”.
 - Release the foot from the speed control pedal.
 - Check the distance between the foot releasing point and the machine stopping point.
 - If the distance is more than approximately 3 m (10 feet), strengthen the HST neutral spring tension so that the machine will stop in approximately 3 m (10 feet) after releasing the foot from the speed control pedal.

(Reference)

Distance (L) between the foot releasing point and the machine stopping point	Reference	Approximately 3 m (10 feet)
--	-----------	-----------------------------

2. Remove the step from the machine.
 - Loosen the lock nut (2).
 - Turn the adjusting nut (3) half turn to pull the HST neutral spring (1).
 - Tighten and lock the lock nut (2).
 - Start the engine and check dynamic brake as mentioned former.
 - If the machine will not stop with dynamic brake in approximately 3 m (10 feet), adjust the neutral spring again.

(Reference)

- The feeling of dynamic braking can be adjusted by changing the arm (6) position of damper (5).

Length (M) of adjusting rod at shipping the machine from the factory	Reference	10 mm 0.39 in.
--	-----------	-------------------

- (1) HST Neutral Spring
- (2) Lock Nut
- (3) Adjusting Nut
- (4) Adjusting Rod
- (5) Damper
- (6) Arm
- (A) Foot Releasing Point
- (B) Machine Stopping Point
- L : Distance between Foot Releasing Point and the Machine Stopping Point
- M : Length of Adjusting Rod from Stay

W1079634



Charge Relief Pressure

CAUTION

- When checking, park the tractor on flat ground, and apply the parking brake.
1. Remove the plug (R 1/4) (1) from the front cover, then install the adaptor (R 1/4) and pressure gauge.
 2. Set the range gear shift lever to “Neutral” position.
 3. Start the engine and run it at the maximum speed.
 4. Read the pressure gauge to measure the charge relief pressure.
 5. If the measurement is not within the factory specifications, check the charge relief valve and related hydraulic components.

NOTE

- When reinstalling the hexagon socket head plug, apply liquid lock (Three Bond 1324 or its equivalent) to the plug.

Charge relief pressure	Factory spec. (Oil temperature at 50 °C, 122 °F)	0.55 to 0.75 MPa 5.6 to 7.7 kgf/cm ² 80 to 100 psi
------------------------	--	---

Tightening torque	Charge relief pressure port plug (R 1/4)	29 to 44 N·m 3.0 to 4.5 kgf·m 22 to 32 lbf·ft
-------------------	--	---

(1) Plug

W1013009



High Relief Pressure (Forward)

CAUTION

- When checking, park the tractor on flat ground, and apply the parking brake.
1. Remove the hexagon socket head plug (R 1/4) from P2 (2), then install the adaptor, cable and pressure gauge.
 2. Start the engine and run it at maximum speed.
 3. Set the range gear shift lever to “Hi” position.
 4. Depress the speed control pedal to “Forward”, and read the pressure gauge to measure the high relief pressure.
 5. If the measurement is not same as factory specification, check the high pressure relief valve and related hydraulic components.

High relief pressure (Forward)	Factory spec. (Oil temperature at 50 °C, 122 °F)	20.1 to 21.1 MPa 205 to 215 kgf/cm ² 2920 to 3060 psi
--------------------------------	--	--

Tightening torque	Hexagon socket head plug (P1 and P2 port)	30 to 44 N·m 3.0 to 4.5 kgf·m 22 to 32 lbf·ft
-------------------	---	---

IMPORTANT

- Measure quickly the high relief pressure within about 10 seconds.

NOTE

- When reinstalling the hexagon socket head plug, apply liquid lock (Three Bond 1324 or its equivalent) to the plug.

(1) P1 Port (Reverse)

(2) P2 Port (Forward)

W1013275





3TAAAAFKP030A

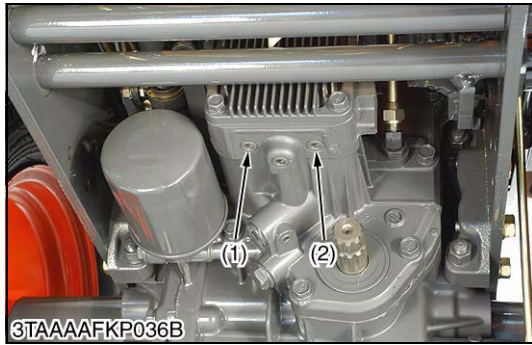

3TAAAAFKP036B



3TAAAAFKP035B

High Relief Pressure (Reverse)

⚠ CAUTION

- When checking, park the tractor on flat ground, and apply the parking brake.
1. Remove the hexagon socket head plug (R 1/4) from **P1** (1), then install the adaptor, cable and pressure gauge.
 2. Start the engine and run it at maximum speed.
 3. Set the range gear shift lever to “Hi” position.
 4. Depress the speed control pedal to “Reverse”, and read the pressure gauge to measure the high relief pressure.
 5. If the measurement is not same as factory specification, check the high pressure relief valve and related hydraulic components.

High relief pressure (Reverse)	Factory spec. (Oil temperature at 50 °C, 122 °F)	20.1 to 21.1 MPa 205 to 215 kgf/cm ² 2920 to 3060 psi
--------------------------------	--	--

Tightening torque	Hexagon socket head plug (P1 and P2 port)	30 to 44 N·m 3.0 to 4.5 kgf·m 22 to 32 lbf·ft
-------------------	---	---

■ IMPORTANT

- Measure quickly the high relief pressure within about 10 seconds.

■ NOTE

- When reinstalling the hexagon socket head plug, apply liquid lock (Three Bond 1324 or its equivalent) to the plug.

(1) P1 Port (Reverse)

(2) P2 Port (Forward)

W1040164

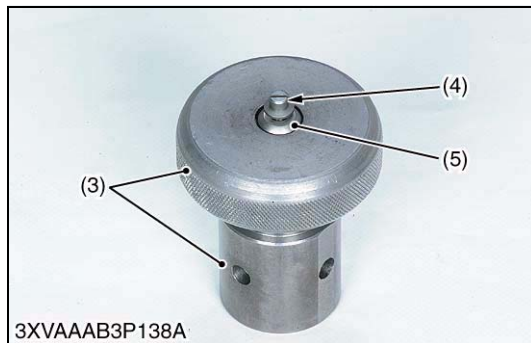
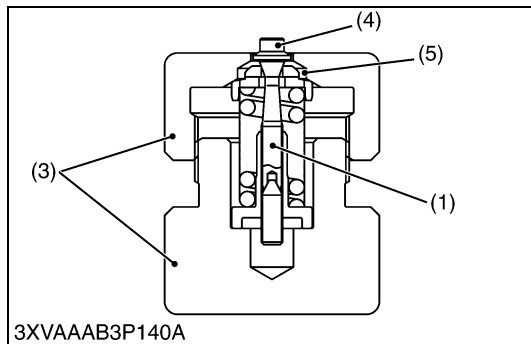
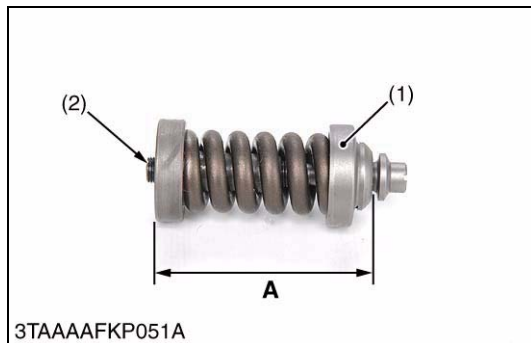

Readjustment of Relief Valve (When the HST does not Work Due to its Loose Hexagon Socket Head Screw)

■ **IMPORTANT**

- KUBOTA does not recommend the readjustment of relief valve. KUBOTA recommends with genuine parts.
- As the HST may be damaged if the pressure is set to high by mistake, be careful when adjusting it.

■ **NOTE**

- The relief pressure is set in between 20.1 to 21.1 MPa (205 to 215 kgf/cm², 2920 to 3060 psi) when shipped from the factory. But, for the purpose of after-sales services, as it is impossible to reset the pressure precisely as set in the factory, its setting range is defined as a slightly wider range between 15.0 to 20.0 MPa (153 to 203 kgf/cm², 2180 to 2900 psi).

1. Measure the pre-adjustment distance **A**.
2. Compress the spring of the relief valve with a relief valve assembling tool (3).
3. Then, find the distance **A** by turning the poppet (4) with a screwdriver.
- Reference: The distance **A** changes by about 0.5 mm (0.02 in.) per one turn of the poppet (4).
4. Repeat the same operation a few times to find the distance **A** as it is difficult to acquire at the first time.
5. After finding the distance **A**, hold the setscrew (6) to a vice and fasten the hexagon socket head screw (2) with specified torque. On this occasion, use a copper plate, etc. for the vice jaws not to damage the setscrew (6).
6. Install the relief valve in the HST.
7. Check the relief pressure as indicated in page 2-S12 and 2-S13. The distance **A** is for refresh only. Make sure to check the relief pressure after readjustment.
8. If the relief pressure does not fall within the readjustment pressure range, repeat the processes of the above.
- Reference: The pressure changes by 1.5 MPa (15 kgf/cm², 210 psi) per 0.1 mm (0.004 in.) in distance **A**.

Tightening torque	Hexagon socket head screw	25 to 29 N·m 2.5 to 3.0 kgf·m 18 to 21 lbf·ft
-------------------	---------------------------	---

Relief valve readjusting pressure	Factory spec.	15.0 to 20.0 MPa 153 to 203 kgf/cm ² 2180 to 2900 psi
-----------------------------------	---------------	--

Distance A of relief valve (Forward)	Reference value	39.10 to 39.20 mm 1.540 to 1.543 in.
---	-----------------	---

Distance A of relief valve (Reverse, φ1.5 mm orifice)	Reference value	38.60 to 38.70 mm 1.520 to 1.523 in.
--	-----------------	---

- | | |
|----------------------------------|---------------------|
| (1) Relief Valve Assembly | (5) Valve Seat |
| (2) Hexagon Socket Head Screw | (6) Setscrew |
| (3) Relief Valve Assembling Tool | |
| (4) Poppet | A : Distance |

W1082809

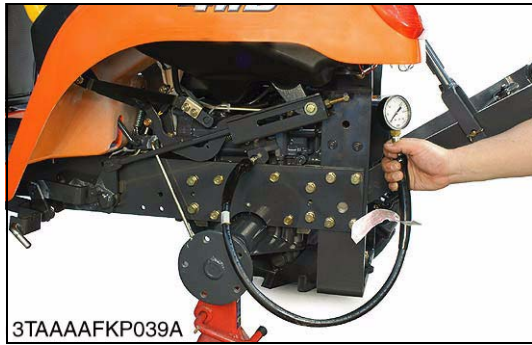

PTO Clutch Operating Pressure

⚠ CAUTION

- When checking, park the tractor on flat ground, apply the parking brake.
1. Lift the rear of the tractor and remove the left rear wheel.
 2. Remove the plug (R 1/8), then install the adaptor (R 1/8), cable and pressure gauge.
 3. Start the engine and set at maximum speed.
 4. Move the PTO clutch lever to “Engaged” position, and measure the pressure.
 5. If the measurement is not same as factory specifications, check the PTO relief valve and related hydraulic components.

■ IMPORTANT

- Do not connect the universal joint of the implement to the mid and rear PTO shaft.

■ NOTE

- When reinstall the hexagon socket head plug, apply liquid lock (Three Bond 1324 or its equivalent) to the plug.

PTO clutch operating pressure	Factory spec.	1.0 to 1.3 MPa 11 to 13 kgf/cm ² 150 to 180 psi
-------------------------------	---------------	--

Tightening torque	PTO clutch valve plug (R 1/8)	13 to 21 N·m 1.3 to 2.2 kgf·m 9.4 to 15 lbf·ft
-------------------	-------------------------------	--

Condition

- Engine speed : Maximum
- Oil temperature : 45 to 55 °C
113 to 131 °F

W1013552

Brake Pedal Free Travel

1. See page G-22.

W1013715

[2] PREPARATION

(1) Separating Transaxle

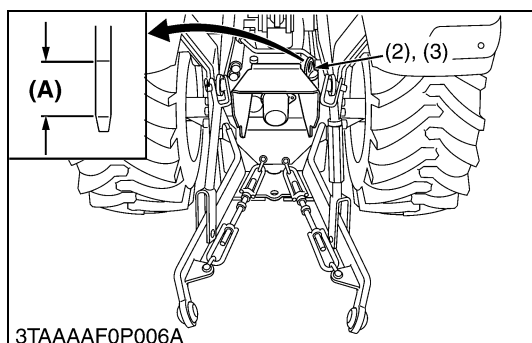
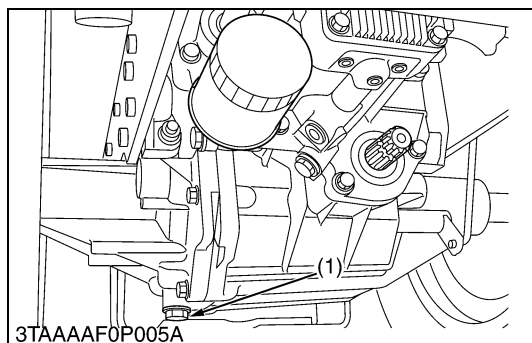

Draining Transmission Fluid

⚠ CAUTION

- Be sure to stop the engine before checking and changing the transmission fluid.

1. Place oil pan under the tractor.
2. Remove the drain plug (1) at the bottom of the transmission case.
3. Drain the transmission fluid and reinstall the drain plug.

(When refilling)

- Fill new oil from filling port after removing the filling plug (2) up to the upper notch on the dipstick (3).
- After running the engine for few minutes, stop it and check the oil level again, if low, add oil to prescribed level.

■ IMPORTANT

- Use only multi-grade transmission oil. Use of other oils may damage the transmission or hydraulic system. Refer to "LUBRICANTS, FUEL AND COOLANT". (See page G-7.)
- Never work the tractor immediately after changing the transmission oil. Keeping the engine at medium speed for a few minutes to prevents damage to the transmission.
- Do not mix different brands oil together.

Transmission fluid capacity	11.6 L 3.1 U.S.gals 2.6 Imp.gals
-----------------------------	--

- (1) Drain Plug
(2) Filling Plug
(3) Dipstick

(A) Oil level is acceptable within this range

W1014039

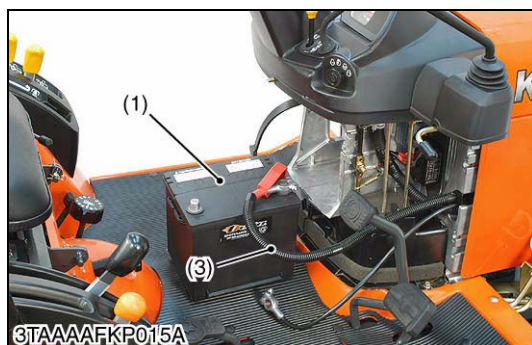

Battery

⚠ CAUTION

- When disconnecting the battery cables, disconnect the negative cable from the battery first. When connecting, connect the positive cable to the battery first.

1. Remove the under panel.
2. Disconnect the negative cable (2) from the battery.
3. Disconnect the positive cable (3) from the battery (1) and remove the battery (1).

- (1) Battery (3) Positive Cable
(2) Negative Cable

W1032888

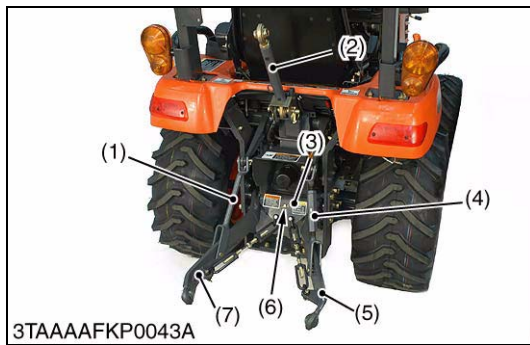

Lift Rod and Lower Link

1. Remove the top link (2).
2. Remove the stopper pin (6) and remove the check chain plate (3).
3. Move the bushes (8) to inside.
4. Move the shaft (9) to right side and remove the lower link as a unit.

- | | |
|-----------------------|-------------------|
| (1) Lift Rod LH | (6) Stopper Pin |
| (2) Top Link | (7) Lower Link LH |
| (3) Check Chain Plate | (8) Bush |
| (4) Lift Rod RH | (9) Shaft |
| (5) Lower Link RH | |

W1045015

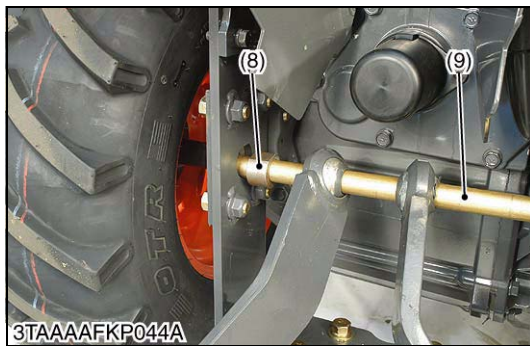

Roll-Over Protective Structures (ROPS)

1. Disconnect the lead wires from the hazard lights (2), (4) and turn signal lights (3), (5).
2. Remove the ROPS mounting nuts, and remove the ROPS (1).

(When reassembling)

Tightening torque	ROPS mounting nut	124 to 147 N·m 12.6 to 15.0 kgf·m 91.2 to 108 lbf·ft
-------------------	-------------------	--



- | | |
|--------------------------|--------------------------|
| (1) ROPS | (4) Hazard Light RH |
| (2) Hazard Light LH | (5) Turn Signal Light RH |
| (3) Turn Signal Light LH | |

W1014508



Seat

1. Disconnect the seat switch connectors.
2. Remove the snap pins(2) to remove the seat (1).

(1) Seat (2) Snap Pin

W1014409

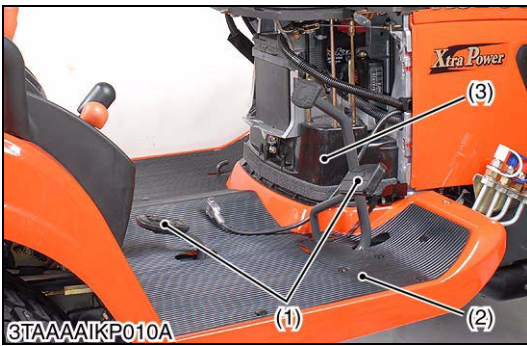

Speed Control Pedal and Step

1. Remove the valve covers (3).
2. Remove the speed control pedals (1) and step (2).

(1) Speed Control Pedal (3) Valve Cover
(2) Step

W1014726

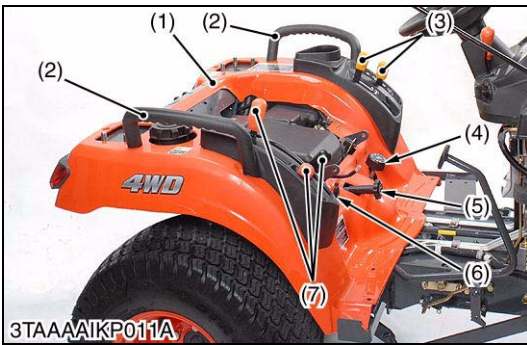

Lever Grips and Fender

1. Disconnect the electric outlet connector (6).
2. Remove the lowering speed adjusting knob (5) and cutting height adjusting dial knob (4).
3. Remove the lever grips (3) and lever guide mounting screw.
4. Remove the fender (1) with lever guide (2).

(1) Fender (4) Cutting Height Adjusting Dial Knob
(2) Lever Guide (5) Lowering Speed Adjusting Knob
(3) Lever Grip (6) Electric Outlet

W1014865

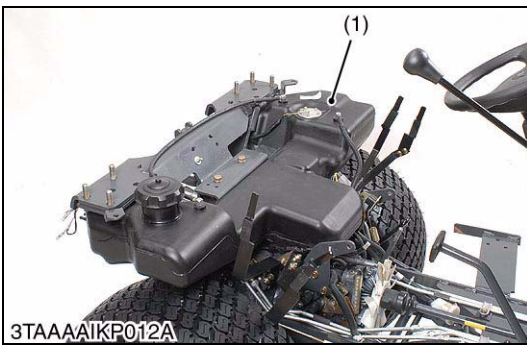

Fuel Tank

1. Drain the fuel.
2. Disconnect the lead wire from fuel level sensor and fuel hoses from the fuel tank (1).
3. Remove the fuel tank stays (2), (3) and cushions, then remove the fuel tank (1).
4. Remove the PTO cover (4).

(When reassembling)

Tightening torque	Fuel tank stay mounting bolt and nut	48 to 55 N·m 4.9 to 5.7 kgf·m 36 to 41 lbf·ft
-------------------	--------------------------------------	---

(1) Fuel Tank (3) Fuel Tank Stay RH
(2) Fuel Tank Stay LH (4) PTO Cover

W1015094

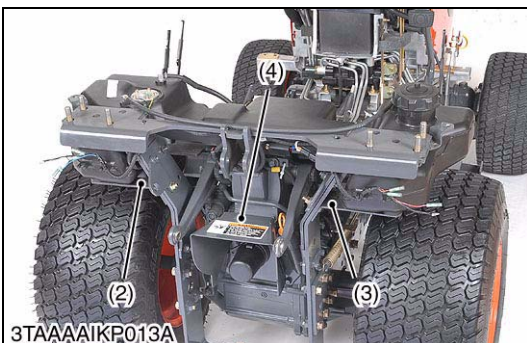

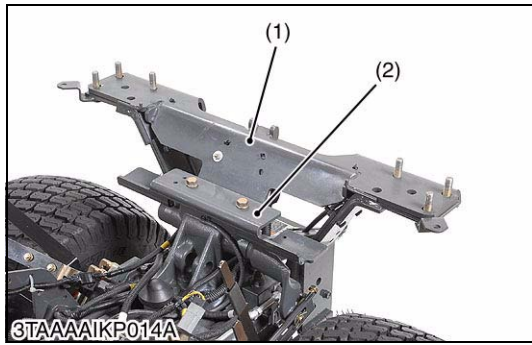

Fender Center Stay

1. Remove the fender bracket (2).
2. Remove the fender center stay (1).

(When reassembling)

Tightening torque	Fender bracket mounting bolt	124 to 147 N·m 12.6 to 15.0 Kgf·m 91.2 to 108 lbf·ft
-------------------	------------------------------	--

(1) Fender Center Stay

(2) Fender Bracket

W1045749



Rear Wheel

1. Remove the rear wheels (1) and (2).

(When reassembling)

Tightening torque	Rear wheel mounting bolt	109 to 129 N·m 11.1 to 13.2 kgf·m 80.3 to 95.4 lbf·ft
-------------------	--------------------------	---

(1) Rear Wheel LH

(2) Rear Wheel RH

W1014976

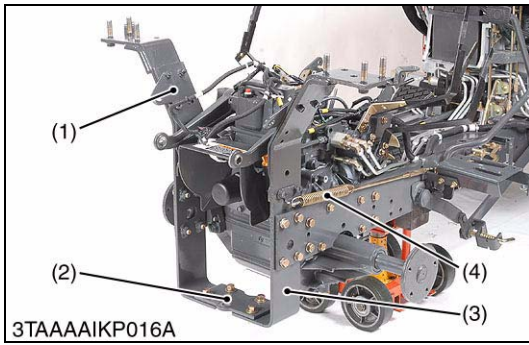

Fender Bracket, Hitch Plate

1. Remove the hitch plate (2).
2. Remove the parking brake return spring (4) and the fender brackets (1), (3).

(When reassembling)

- Do not firmly tighten all screws, bolts and nuts until most components are attached.

Tightening torque	Hitch plate mounting bolt and nut (M14)	124 to 147 N·m 12.6 to 15.0 kgf·m 91.2 to 108 lbf·ft
	Fender bracket mounting bolt and nut (M14)	124 to 147 N·m 12.6 to 15.0 kgf·m 91.2 to 108 lbf·ft

- (1) Fender Bracket LH
(2) Hitch Plate

- (3) Fender Bracket RH
(4) Return Spring

W1024983

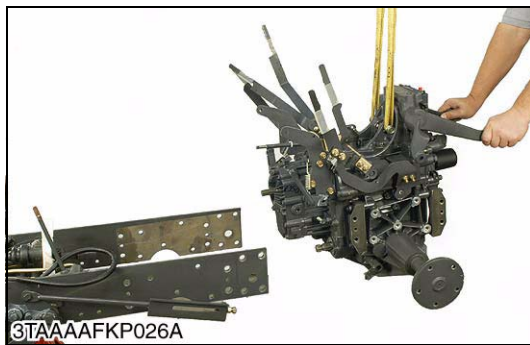
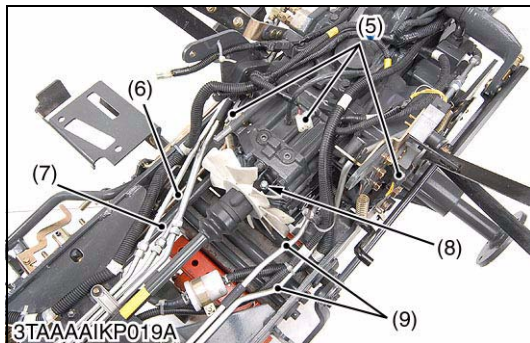
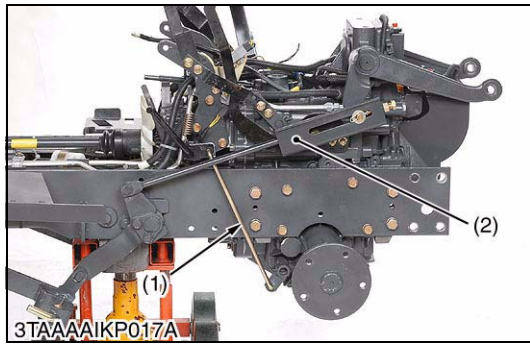

Transaxle Assembly

1. Remove the differential lock rod (1) and disconnect the mower link (2).
2. Remove the brake rod (4).
3. Disconnect the pipes (3). (If equipped.)
4. Disconnect the connector (5).
5. Remove the rear coupling mounting bolt (8).
6. Disconnect the power steering pipes (9).
7. Remove the speed control rod (7).
8. Remove the wire harness clamps
9. Remove the frame brackets (10).

(When reassembling)

- Tighten the smaller bolt (M12) first.
- Before mounting the transaxle assembly on the tractor main frame, check the flatness of the frame brackets with a straight edge securely.

Tightening torque	Transaxle assembly mounting bolt (M12)	63 to 72 N·m 6.4 to 7.4 kgf·m 47 to 53 lbf·ft
	Transaxle assembly mounting bolt (M14)	124 to 147 N·m 12.6 to 15.0 kgf·m 91.2 to 108 lbf·ft
	Rear coupling mounting bolt (M8)	24 to 27 N·m 2.4 to 2.8 kgf·m 18 to 20 lbf·ft

(Reference)

- Speed control rod length (7) : 371 mm (14.6 in.)

- | | |
|---------------------------|---------------------------------|
| (1) Differential Lock Rod | (6) Front Wheel Drive Shaft |
| (2) Mower Link | (7) Speed Control Rod |
| (3) Pipe | (8) Rear Coupling Mounting Bolt |
| (4) Brake Rod | (9) Power Steering Pipe |
| (5) Connector | (10) Frame Bracket |

W1016000

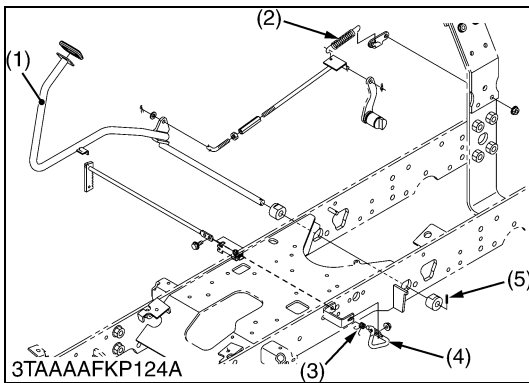

Brake Pedal and Propeller Shaft

1. Unhook the spring (3) and the parking plate (4).
2. Removing the spring pin (5) from the brake pedal (1). Disconnect the brake spring (2) and remove the brake pedal (1).
3. Disconnect the front coupling (6) from the engine.
4. Remove the propeller shaft assembly.
5. Remove the HST fan from the propeller shaft.

(When reassembling)

- Apply grease to inside of the front coupling and the rear coupling.

Tightening torque	Front coupling mounting bolt (M8)	24 to 27 N·m 2.4 to 2.8 kgf·m 18 to 20 lbf·ft
	HST fan mounting bolt (M8)	9.8 to 11 N·m 1.0 to 1.2 kgf·m 7.3 to 8.6 lbf·ft

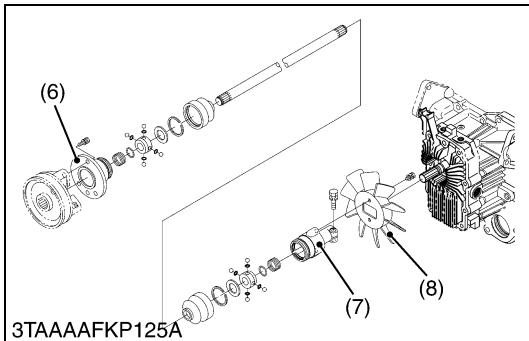

- | | |
|-------------------|--------------------|
| (1) Brake Pedal | (5) Spring Pin |
| (2) Brake Spring | (6) Front Coupling |
| (3) Spring | (7) Rear Coupling |
| (4) Parking Plate | (8) HST Fan |

W1016476

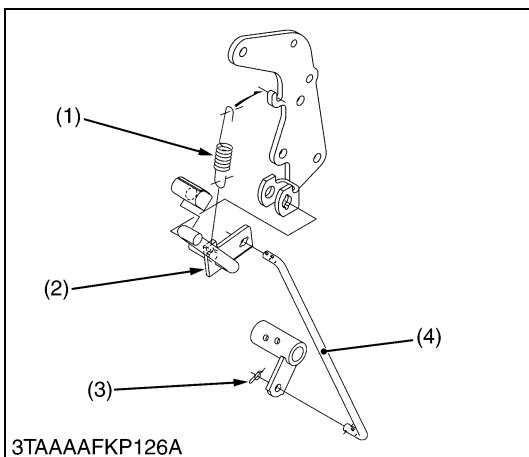

Differential Lock Pedal

1. Remove the differential lock return spring (1).
2. Remove the rue ring cotter (3).
3. Turn and remove the differential lock pedal (2).

- | | |
|-----------------------------|---------------------------|
| (1) Spring | (3) Rue Ring Cotter |
| (2) Differential Lock Pedal | (4) Differential Lock Rod |

W1016728

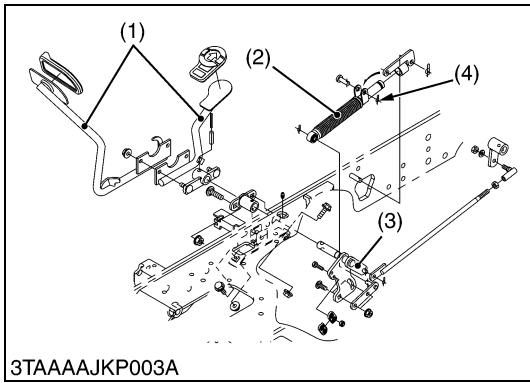

Speed Control Pedal, HST Damper and Cruise Rod

1. Remove the speed control pedal (1).
2. Remove the rue ring cotter (4).
3. Remove the HST dumper (2).
4. Remove the release arm (7).
5. Remove the spring (6) and the cruise rod (5).
6. Remove the cruise lock (8).

- | | |
|-------------------------|-----------------|
| (1) Speed Control Pedal | (5) Cruise Rod |
| (2) HST Dumper | (6) Spring |
| (3) HST Pedal Link | (7) Release Arm |
| (4) Rue Ring Cotter | (8) Cruise Lock |

W1016858

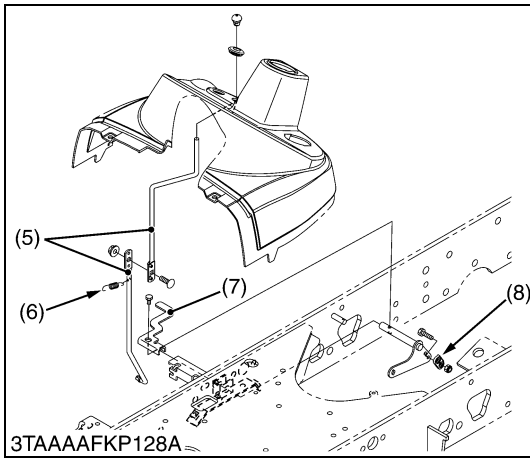

[3] DISASSEMBLING AND ASSEMBLING

(1) Hydrostatic Transmission

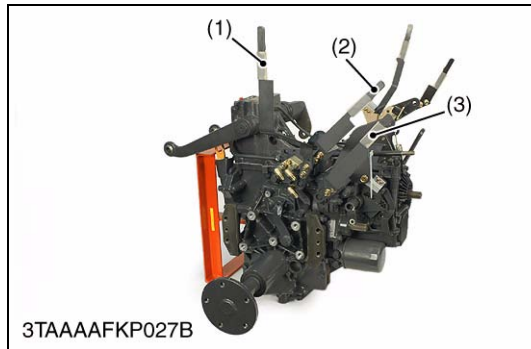

Levers and Mower Lift Arm

1. Tap out the spring pin from the range gear shift lever (1) and front wheel drive lever (3), then remove the both levers.
2. Remove the hydraulic control lever (2).
3. Remove the PTO select lever (4) and PTO clutch control lever (5).

(When reassembling)

- Apply grease to inside of the front coupling and rear mounting.

Tightening torque	Hydraulic control lever mounting bolt and nut	18 to 20 N·m 1.8 to 2.1 kgf·m 13 to 15 lbf·ft
-------------------	---	---

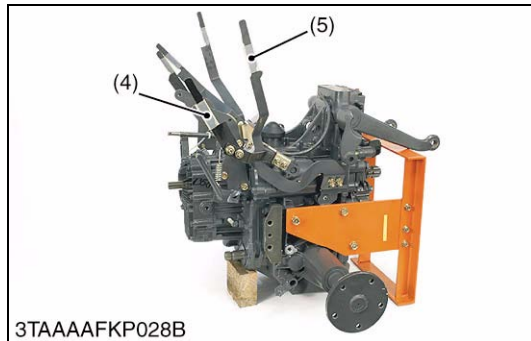

- | | |
|-----------------------------|------------------------------|
| (1) Range Gear Shift Lever | (4) PTO Select Lever |
| (2) Hydraulic Control Lever | (5) PTO Clutch Control Lever |
| (3) Front Wheel Drive Lever | |

W1017118



PTO Clutch Valve

1. Remove the stopper (1).
2. Draw out the PTO clutch valve (2) from the transaxle assembly.

(When reassembling)

1. Clean the oil passages (4).
2. Apply the transmission fluid to the O-rings (3).

- | | |
|----------------------|-----------------|
| (1) Stopper | (3) O-ring |
| (2) PTO Clutch Valve | (4) Oil Passage |

W1086372

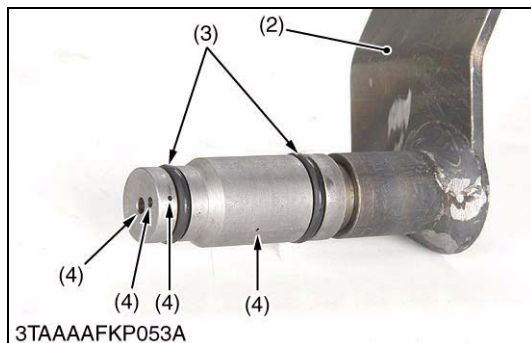

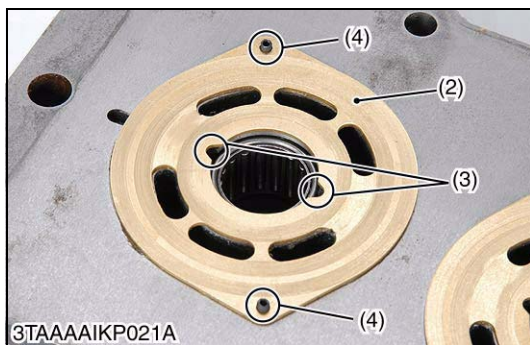
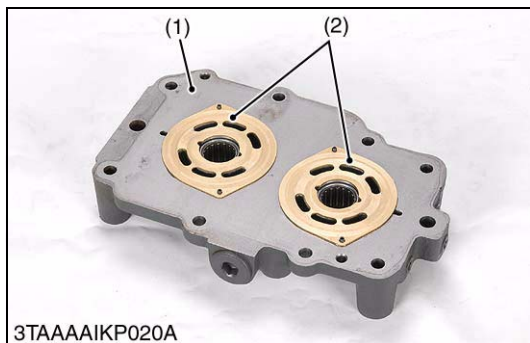
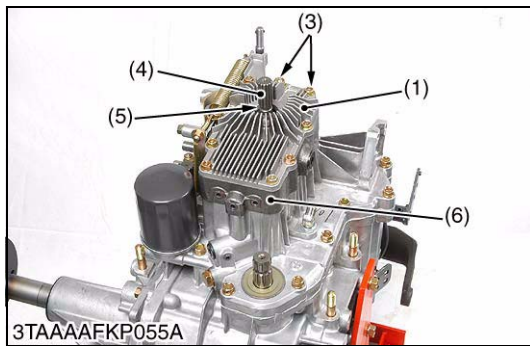
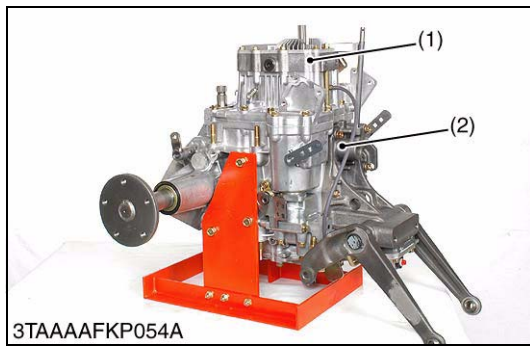

Oil Cooler Cover

1. Remove the HST front cover.
2. Remove the HST front cover (1) not to damage the oil seal (5).
3. Remove the center section (6).

(When reassembling)

1. Do not damage the oil seal (5).
2. Tighten the HST mounting bolts and the nut to the factory specifications.

Tightening torque	Oil cooler cover mounting bolt (M8)	18 to 20 N·m 1.8 to 2.1 kgf·m 13 to 15 lbf·ft
	Oil cooler cover mounting nut (M8)	18 to 20 N·m 1.8 to 2.1 kgf·m 13 to 15 lbf·ft

- | | |
|------------------------|-----------------------|
| (1) HST Front Cover | (4) Internal Cir-clip |
| (2) Transaxle Assembly | (5) Oil Seal |
| (3) Bolt | (6) Center Section |

W1086612

Center Section and Valve Plates

1. Remove the valve plates (2).

(When reassembling)

1. Check the direction of the groove (3).
2. Install the valve plates (2) to the anchor pins (4) securely.
3. Install the groove of the valve plate (pump plate) to the engine side.

- | | |
|--------------------|----------------|
| (1) Center Section | (3) Groove |
| (2) Valve Plate | (4) Anchor Pin |

W1086956

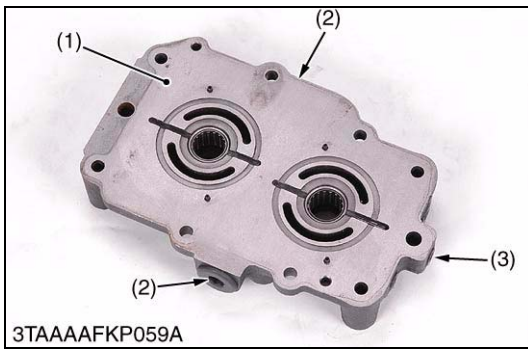

Check and High Pressure Relief Valve Plug

1. Remove the check and high pressure relief plug (G 1/2).

(When reassembling)

Tightening torque	Check and high pressure relief valve plug (G 1/2)	59 to 78 N·m 6.0 to 8.0 kgf·m 44 to 57 lbf·ft
-------------------	---	---

(1) Center Section
(2) Plug

(3) Plug

W1087469

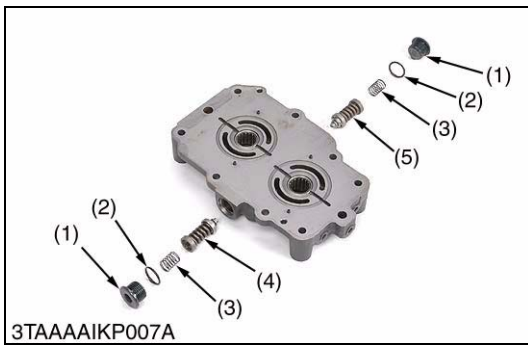

Check and High Pressure Relief Valve

1. After removing the plug (1), draw out the spring (3) and the check and high pressure relief valve assembly (4) (5).

(When reassembling)

- Take care not to damage the O-ring (2) on the plug (1).
- Since there is an orifice (1.5 mm, 0.059 in.) in the check and relief valve body (reverse) (5), re-install the check and relief valve (4) (5) to their original positions.

(1) Plug
(2) O-ring
(3) Spring

(4) Check and Relief Valve (Forward)
(5) Check and Relief Valve (Reverse)

W1087625

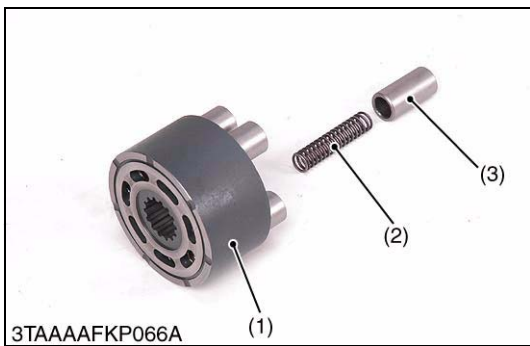
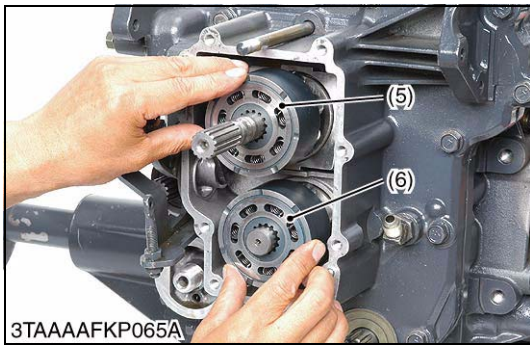
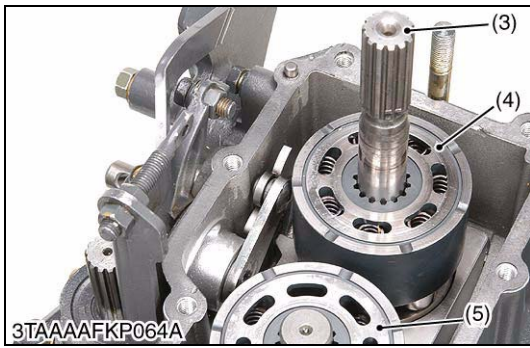
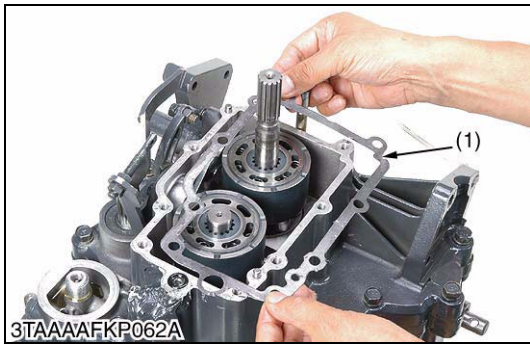

Cylinder Block

1. Remove the gasket (1).
2. Remove the O-ring (2).
3. Remove the cylinder block assembly (4) (5) from the transaxle.

(When reassembling)

- Turn the disassembling and the assembling stand vertically.
- Install the cylinder block assembly (4) (5) to the shafts not to drop the pistons from the cylinder block assembly (4) (5) carefully.

- | | |
|---|--|
| (1) Gasket | (5) Cylinder Block Assembly (Pump Side) |
| (2) O-ring | (6) Cylinder Block Assembly (Motor Side) |
| (3) Pump Shaft | |
| (4) Cylinder Block Assembly (Pump Side) | |

W1087850

Cylinder Block and Piston

1. Remove the piston (3) and the spring (2) from the cylinder block (1).

(When reassembling)

- Apply clean transmission oil to the cylinder block and the piston.

■ NOTE

- Take care not to damage the surface of the cylinder block and the piston.

- | | |
|--------------------|------------|
| (1) Cylinder Block | (3) Piston |
| (2) Spring | |

W1088078

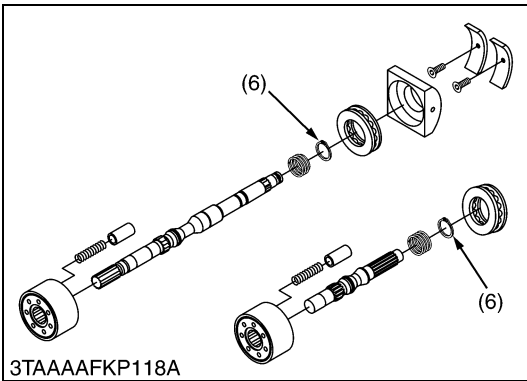

Swashplate and Thrust Roller Bearing

1. Remove the cir-clip (6) from the pump shaft (3) and the motor shaft (1).
2. Remove the thrust bearing (2).
3. Remove the swashplate (5) and the thrust roller bearing (4).

(When reassembling)

- Apply clean transmission oil to the cradle bearing and the trunnion arm.
- Hold the slot guide with a minus screw driver.
- Apply clean transmission oil to the thrust roller bearing.

- | | |
|---------------------------|--------------------|
| (1) Motor Shaft | (5) Swashplate |
| (2) Thrust Roller Bearing | (6) Cir-Clip |
| (3) Pump Shaft | (7) Slot Guide |
| (4) Thrust Roller Bearing | (8) Cradle Bearing |

W1088366

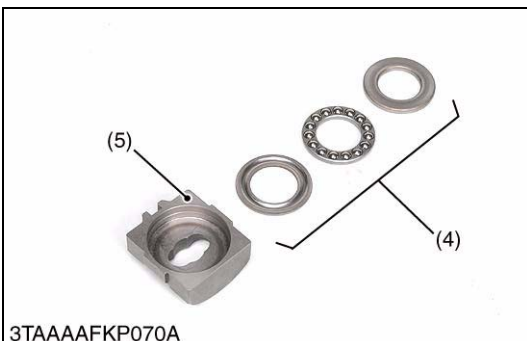
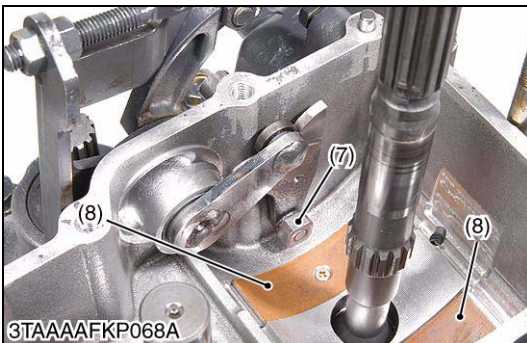
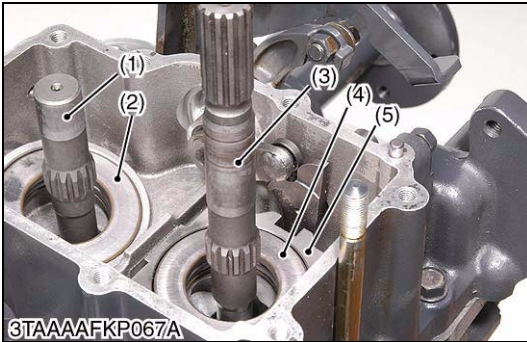

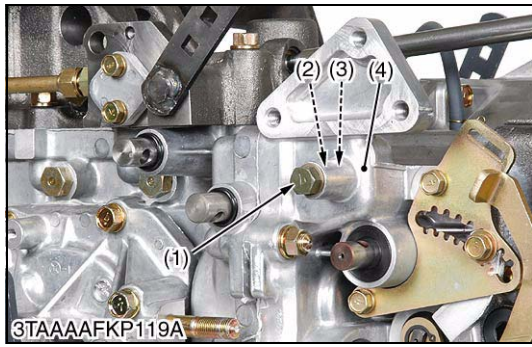

4WD Detent Ball

1. Remove the 4WD detent bolt (1), the detent spring (2) and the detent ball (3) before removing the transaxle front case, not to drop the detent ball (3) into the transaxle case.

- | | |
|---------------------|--------------------------|
| (1) 4WD Detent Bolt | (3) Detent Ball |
| (2) Detent Spring | (4) Transaxle Front Case |

W1102203

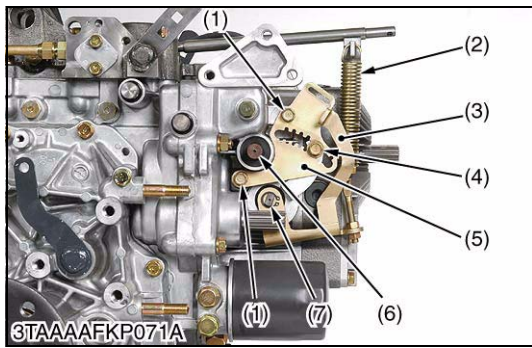

Neutral Arm and Trunnion Arm

1. Disconnect the neutral spring(2) from the HST front cover.
2. Loosen the neutral adjuster (5).
3. Remove the external cir-clip (7).
4. Remove the bolts (1).
5. Remove the neutral adjuster (5) and the neutral arm (3).
6. Remove the trunnion arm (6).

(When reassembling)

- Adjust the HST neutral position. Refer to “**Checking and Adjusting**” section.

- | | |
|--------------------|-----------------------|
| (1) Bolt | (5) Neutral Adjuster |
| (2) Neutral Spring | (6) Trunnion Arm |
| (3) Neutral Arm | (7) External Cir-clip |
| (4) Lock Screw | |

W1088807

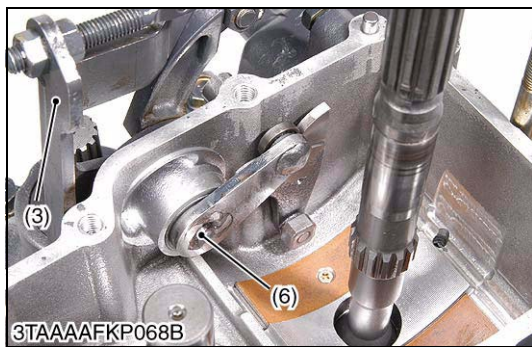

(2) Hydraulic Cylinder

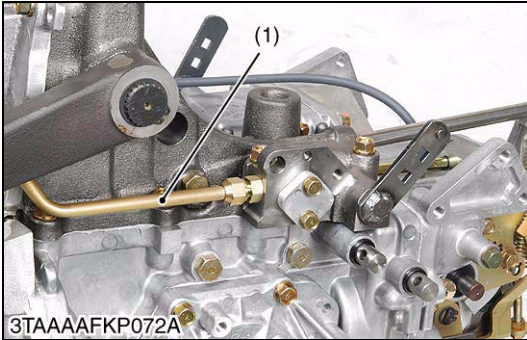

Hydraulic Cylinder

1. Disconnect the delivery pipe (1).
2. Remove the hydraulic cylinder mounting bolts (3).
3. Remove the hydraulic cylinder (2).

(When reassembling)

- Apply liquid gasket (Three Bond 1208D or equivalent) to the joint surface of the transaxle case to the hydraulic cylinder.

Tightening torque	Hydraulic cylinder mounting bolt	40 to 44 N·m 4.0 to 4.5 kgf·m 29 to 32 lbf·ft
-------------------	----------------------------------	---

- (1) Delivery Pipe
(2) Hydraulic Cylinder

- (3) Bolt

W1089147

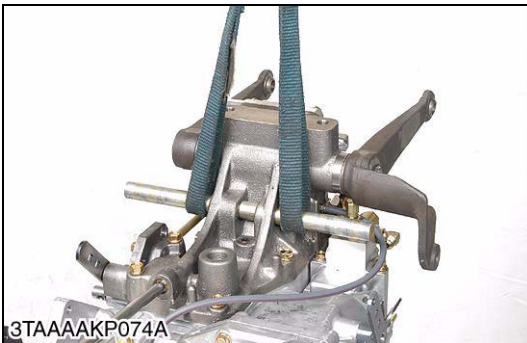
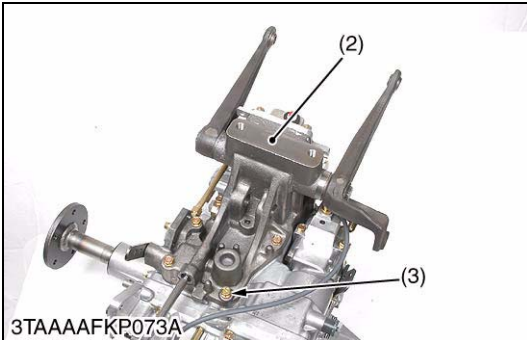

(3) Transaxle Shafts

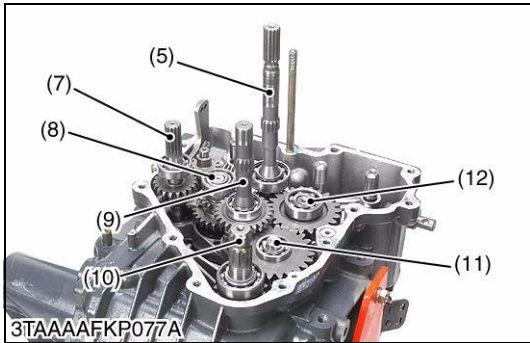
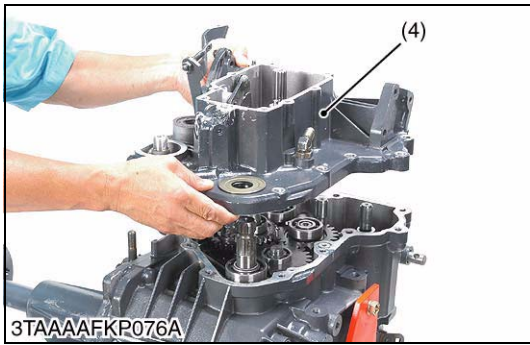
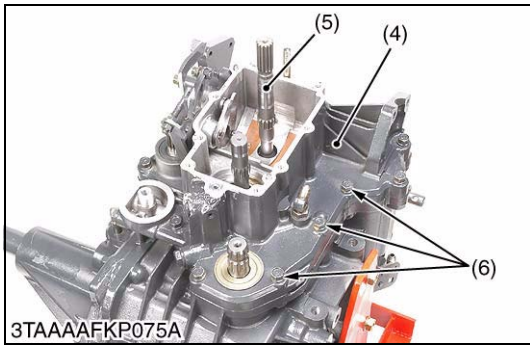
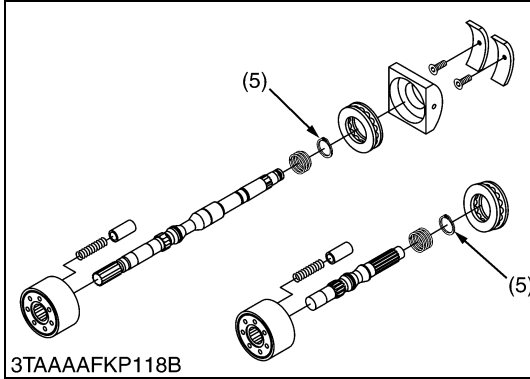
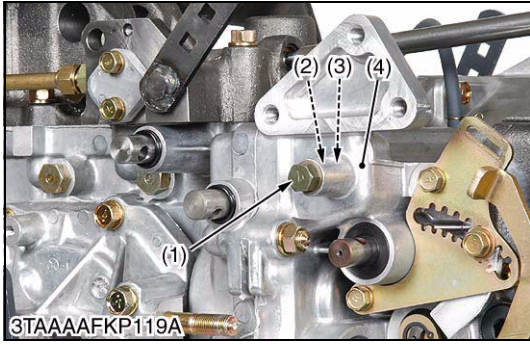

Transaxle Case Front Cover

■ **NOTE**

- Before removing the transaxle case front cover (4), remove the 4WD detent bolt (1), the detent spring (2) and the detent ball (3) from the transaxle case front cover (4).
- Remove the cir-clip (5) from the HST pump shaft (PTO shaft) from the HST pump shaft (5) and the HST motor shaft securely.

1. Remove the transaxle case front cover mounting bolts (2).
2. Remove the transaxle case front cover as an unit.

(When reassembling)

- Apply liquid gasket (Three Bond 1208D or equivalent) to the joint surface of the transaxle case to the front cover.

Tightening torque	Transaxle case front cover mounting bolt (M18)	30 to 34 N·m 3.0 to 3.5 kgf·m 22 to 25 lbf·ft
-------------------	--	---

- | | |
|--------------------------------|------------------------------|
| (1) Transaxle Case Front Cover | (7) 4WD Shaft |
| (2) Detent Spring | (8) Pinion Shaft |
| (3) Detent Ball | (9) HST Motor Shaft |
| (4) Transaxle Case Front Cover | (10) Mid-PTO Shaft |
| (5) HST Pump Shaft (PTO Shaft) | (11) Mid-PTO Idle Gear Shaft |
| (6) Bolt | (12) PTO Select Shaft |

W1089420

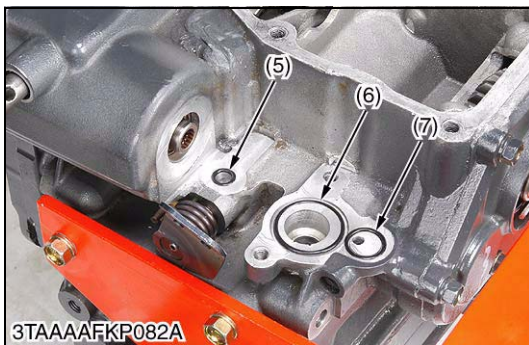
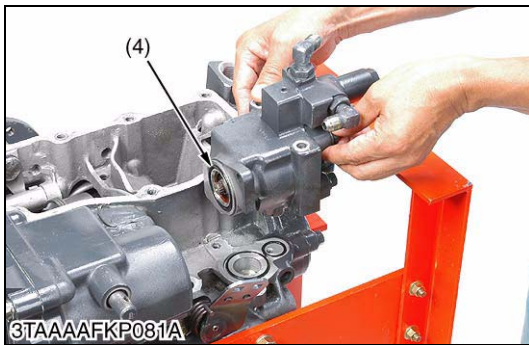
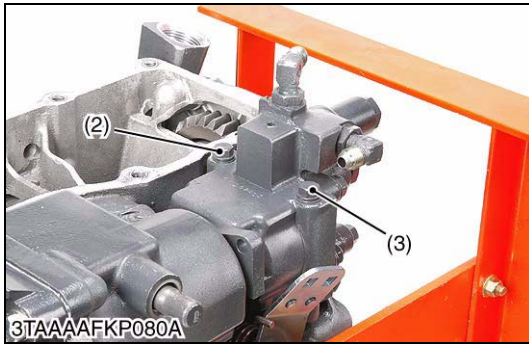
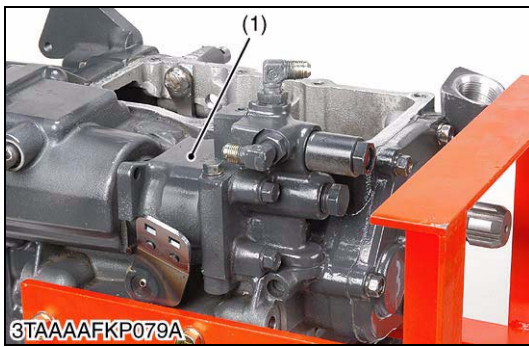

Hydraulic Pump Assembly

1. Remove the hydraulic pump assembly mounting bolt (2), (3).
2. Remove the hydraulic pump assembly (1) as an unit from the transaxle case.

(When reassembling)

- Apply transmission oil to the O-rings.
- Since the mounting bolt (2) is installed through the hydraulic pump to the transaxle case, bind the sealing tape to the mounting bolt (2) securely.

Tightening torque	Hydraulic pump assembly mounting bolt (M6)	7.9 to 8.8 N·m 0.80 to 0.90 kgf·m 5.8 to 6.5 lbf·ft
	Hydraulic pump assembly mounting bolt (M8)	18 to 20 N·m 1.8 to 2.1 kgf·m 13 to 15 lbf·ft

- | | |
|-------------------------|------------|
| (1) Hydraulic Pump | (5) O-ring |
| (2) Bolt (Through Bolt) | (6) O-ring |
| (3) Bolt | (7) O-ring |
| (4) O-ring | |

W1089827

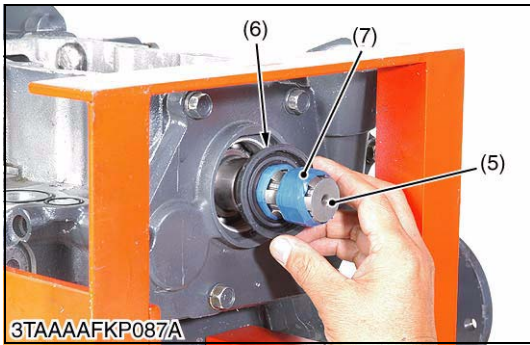
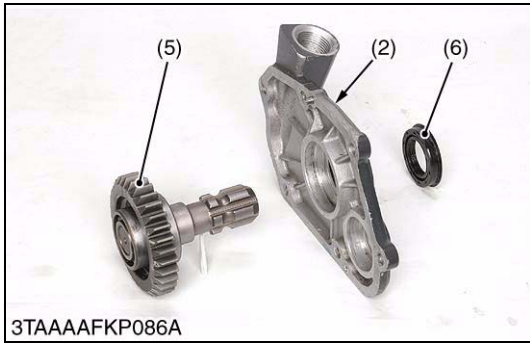
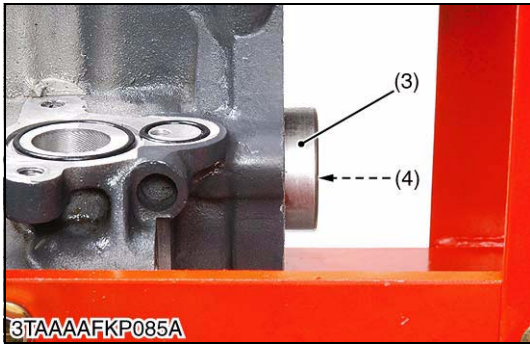
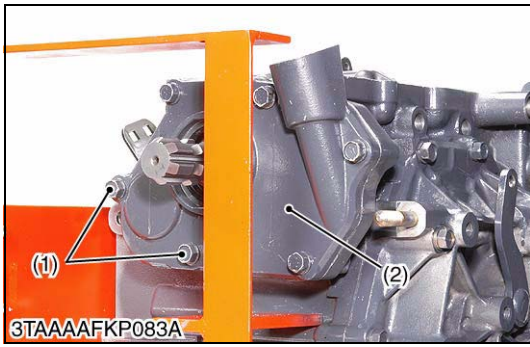

Rear PTO Cover Assembly

1. Remove the rear PTO cover mounting bolts (1).
2. Remove the rear PTO cover (2).
3. Remove the rear PTO shaft (5) from the rear PTO cover (2).

(When reassembling)

- Pull the 11T PTO select shaft with the bearing approximately the bearing thickness.
- Apply liquid gasket (Three Bond 1208D or equivalent) to the joint surface of transaxle case to the rear PTO cover.
- Bind the vinyl tape to the rear PTO shaft not to damage the oil seal.

Tightening torque	Rear PTO cover mounting bolt (M8)	18 to 20 N·m 1.8 to 2.1 kgf·m 13 to 15 lbf·ft
-------------------	-----------------------------------	---

- | | |
|--------------------------|--------------------|
| (1) Bolt | (5) Rear PTO Shaft |
| (2) Rear PTO Cover | (6) Oil Seal |
| (3) Bearing | (7) Vinyl Tape |
| (4) 11T PTO Select Shaft | |

W1090219

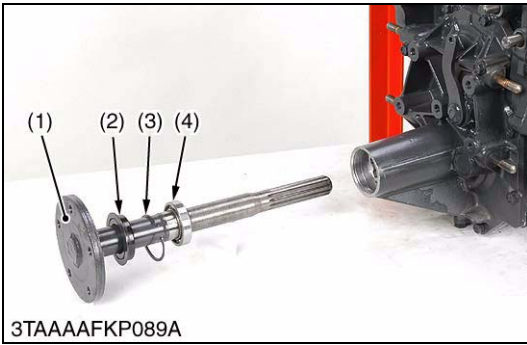
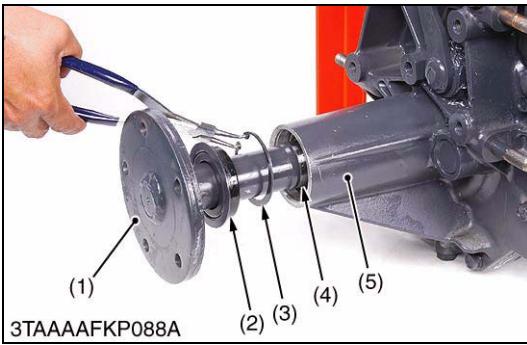

Rear Axle (LH)

■ NOTE

- Prepare a specially bent snap ring pillar.

1. Draw out the oil seal with a screw driver.
2. Remove the internal cir-clip from the rear axle case.
3. Draw out the rear axle from the rear axle case.

(When reassembling)

- Do not damage the oil seal.

- | | |
|-----------------------|--------------------|
| (1) Rear Axle | (4) Ball Bearing |
| (2) Oil Seal | (5) Rear Axle Case |
| (3) Internal Cir-clip | |

W1090759

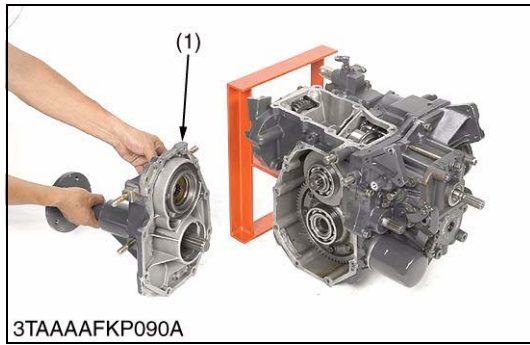

Rear Axle Case (RH)

1. Remove the rear axle case (RH) mounting bolts.
2. Remove the rear axle case (RH) (1) as an assembly from the transaxle case.

■ **NOTE**

- **Since the adjusting shims are installed behind the 37T spiral bevel gear, check the shims.**
3. Remove the 37T spiral bevel gear (2).
 4. Remove the 10T final gear shaft (3).
 5. Remove the 66T final gear with the differential lock shift fork.

(When reassembling)

- Apply liquid gasket (Three Bond 1208D or equivalent) to the joint surface of transaxle case to the rear axle (RH) case.

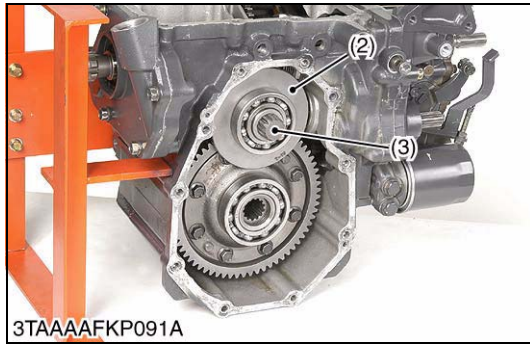

Tightening torque	Rear axle case (RH) mounting bolt (M8)	18 to 20 N·m 1.8 to 2.1 kgf·m 13 to 15 lbf·ft
-------------------	--	---

- | | |
|---------------------------|--|
| (1) Rear Axle Case (RH) | (3) 10T Final Gear Shaft (Brake Shaft) |
| (2) 37T Spiral Bevel Gear | (4) 66T Final Gear |

W1091120

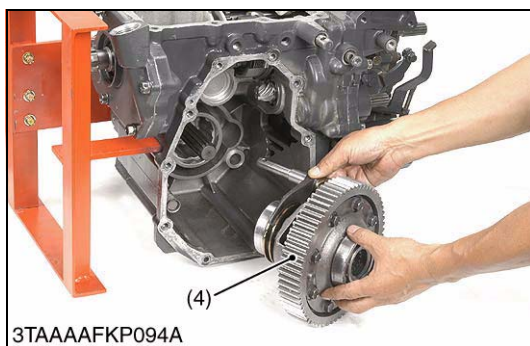
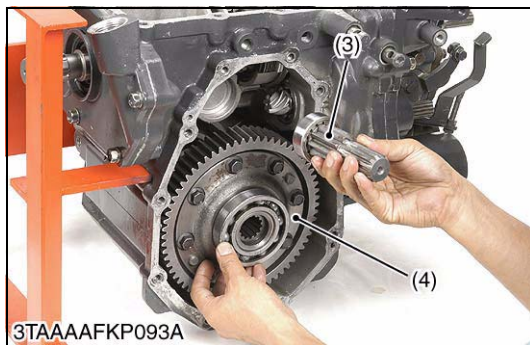
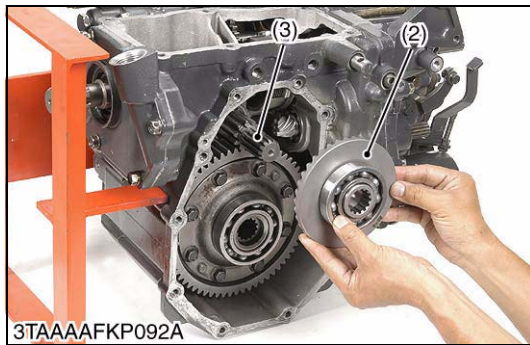

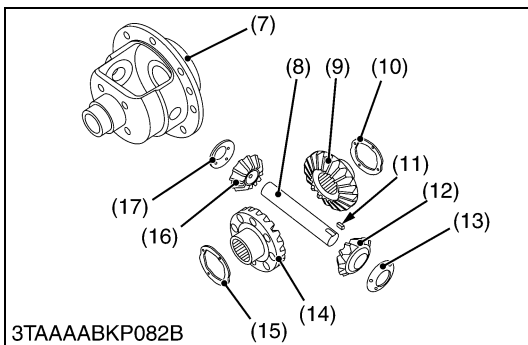
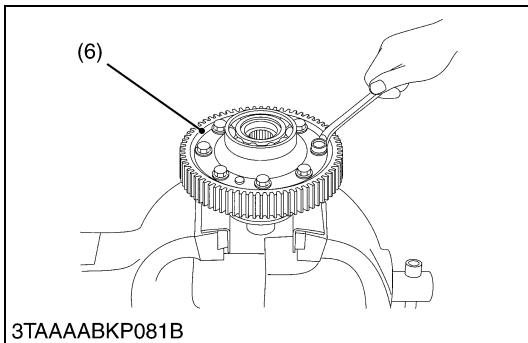
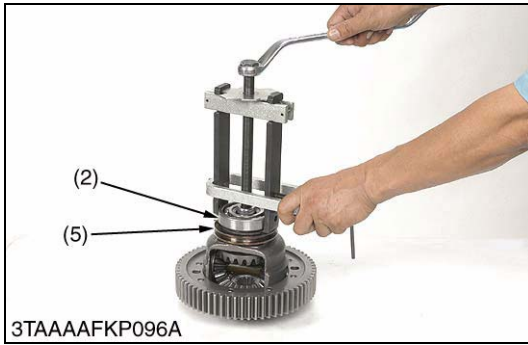
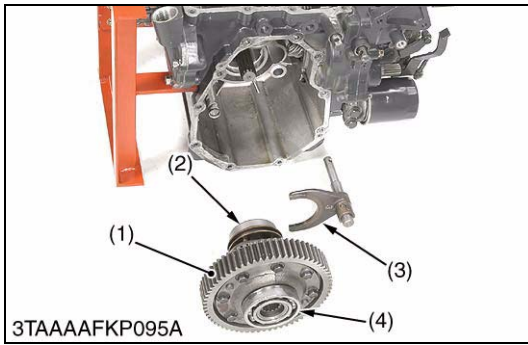

66T Final Gear

1. Remove the bearing (2) with a puller.
2. Remove the bearing (4) with a puller.
3. Remove the differential lock shifter (5) and 66T final gear (6).
4. Put parting marks on the differential pinions (12), (16) and the differential side gears (9), (14).
5. Tap out the differential pinion shaft (8).
6. Remove the differential pinions (12), (16), the differential pinion washers (13), (16), differential side gears (9), (14) and the differential side gear washers (10), (15).

(When reassembling)

- Install the differential pinion and differential gear, aligning the parting marks.
- Lock the differential pinion shaft (8) by setting the key (11).

Tightening torque	66T final gear mounting bolt	61 to 70 N·m 6.2 to 7.2 kgf·m 45 to 52 lbf·ft
-------------------	------------------------------	---

- | | |
|----------------------------------|------------------------------------|
| (1) 66T Final Gear | (10) Differential Side Gear Washer |
| (2) Bearing | (11) Key |
| (3) Differential Lock Shift Folk | (12) Differential Pinion |
| (4) Bearing | (13) Differential Pinion Washer |
| (5) Differential Lock Shifter | (14) Differential Side Gear |
| (6) 66T Final Gear | (15) Differential Side Gear Washer |
| (7) Differential Case | (16) Differential Pinion |
| (8) Differential Pinion Shaft | (17) Differential Pinion Washer |
| (9) Differential Side Gear | |

W1091475

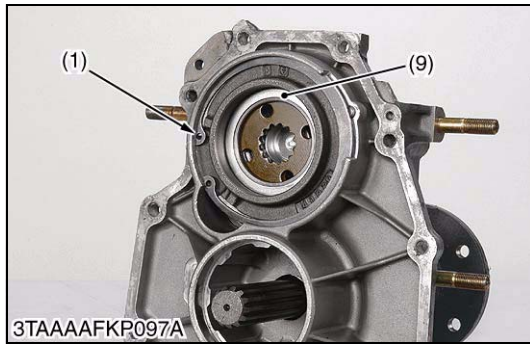

Rear Axle Case, RH and Brake

1. Remove the internal cir-clip (1).
2. Remove the shim (9), the bearing holder (8) and the other brake parts from the brake case.

(When reassembling)

- Apply grease to the steel balls.
- Take care not to damage the O-ring on the brake cam lever.
- Check that the brake cam lever moves smoothly.

- | | |
|-----------------------|--------------------|
| (1) Internal Cir-clip | (6) Brake Disc |
| (2) Brake Cam Lever | (7) Friction Plate |
| (3) External Cir-clip | (8) Bearing Holder |
| (4) Steel Ball | (9) Shim |
| (5) Actuator | |

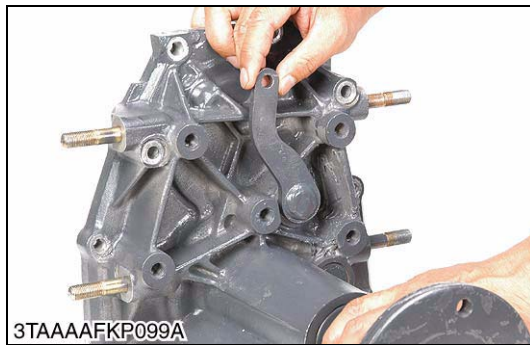
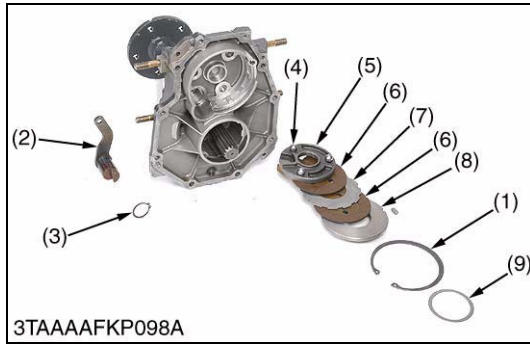

W1091813

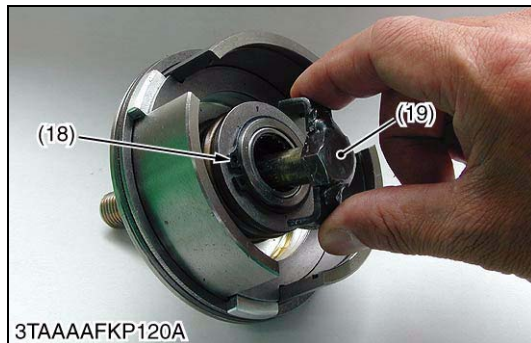
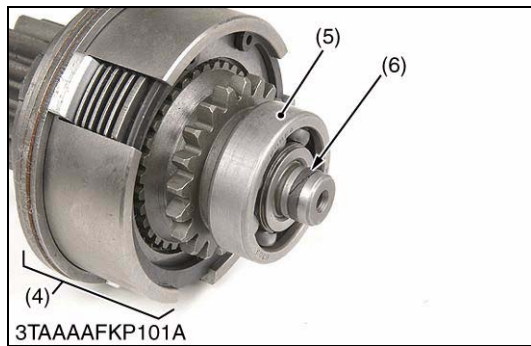
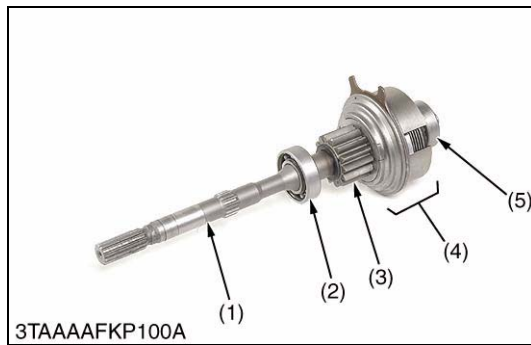

PTO Clutch Assembly

1. Remove the bearing (2).
2. Remove the external cir-clip and the outlet gear (3).
3. Remove the seal rings (6).
4. Remove the bearing (5).
5. Remove the external cir-clip (18) using a clutch spring compressor.
6. Disassembling the clutch pack inner parts as show in the figure.

(When reassembling)

- Change the seal rings (6) with a new one.

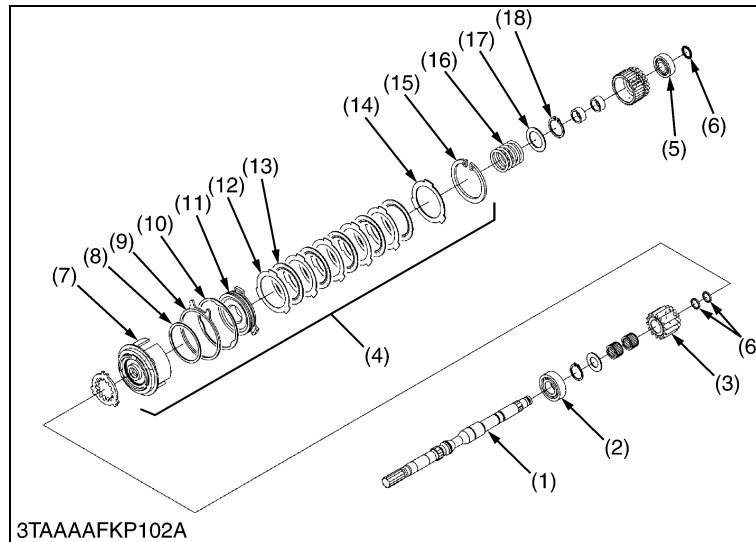

- | | |
|-----------------------------------|-------------------------------|
| (1) Pump Shaft (PTO Clutch Shaft) | (10) Brake Plate |
| (2) Bearing | (11) Clutch Piston |
| (3) Clutch Gear | (12) Separate Plate |
| (4) Clutch Pack | (13) Disc Plate |
| (5) Bearing | (14) Backing Plate |
| (6) Seal Ring | (15) Internal Cir-clip |
| (7) Clutch Case | (16) Brake Spring |
| (8) O-ring | (17) Washer |
| (9) Brake Disc | (18) External Cir-clip |
| | (19) Clutch Spring Compressor |

W1092125

(4) Assembling Shafts

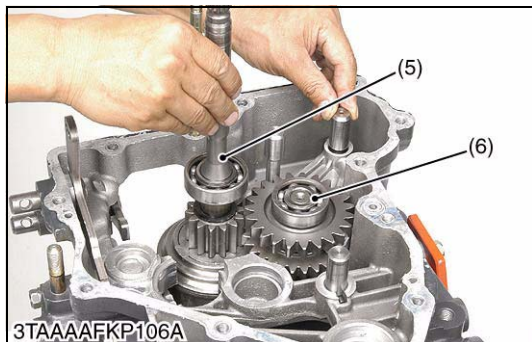
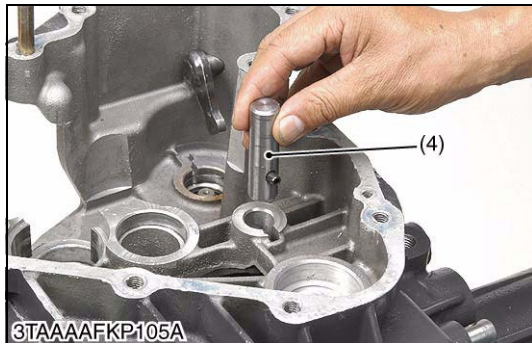
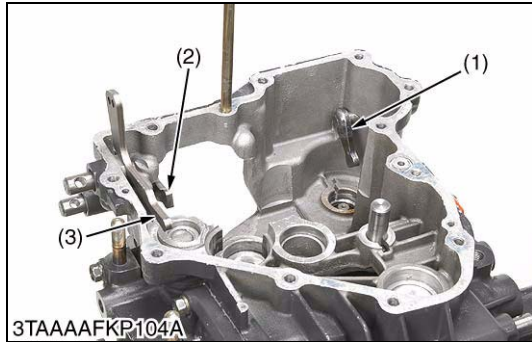
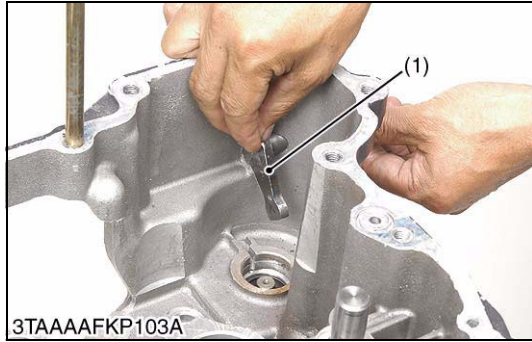

Assembling Select Arms and HST Pump Shaft (PTO Clutch Shaft)

1. Install the PTO select arm (1).
2. Install the range shift arm (2) and the front wheel drive shaft arm (3).
3. Install the idle gear shaft.

■ **NOTE**

- **Install the rear PTO cover and the PTO select gear shaft before installing HST pump shaft assembly.**
4. After installing the rear PTO cover to the transaxle case, install the PTO select gear shaft (6).
 5. Install the HST pump shaft (PTO clutch shaft) (6).

(When reassembling)

- Take care not to damage the O-rings on the arms.

- | | |
|---------------------------------|---------------------------------------|
| (1) PTO Select Arm | (4) Mid-PTO Idle Gear Shaft |
| (2) Range Shift Arm | (5) HST Pump Shaft (PTO Clutch Shaft) |
| (3) Front Wheel Drive Shift Arm | (6) PTO Select Gear Shaft |

W1092555

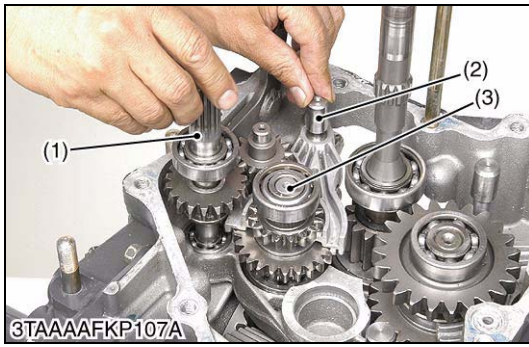

Front Wheel Drive Shaft, Shifter, Spiral Bevel Pinion Shaft and Mid-PTO Shaft

1. Install the front drive shaft (1).
2. Install the shifter (2) and the spiral bevel pinion shaft (3) together.
3. Install the mid-PTO idle gear shaft (5) and the mid-PTO shaft (6) and the HST motor shaft (4) together.

- | | |
|-------------------------------|-----------------------------|
| (1) Front Wheel Drive Shaft | (4) HST Motor Shaft |
| (2) Shifter | (5) Mid-PTO Idle Gear Shaft |
| (3) Spiral Bevel Pinion Shaft | (6) Mid-PTO Shaft |

W1092968

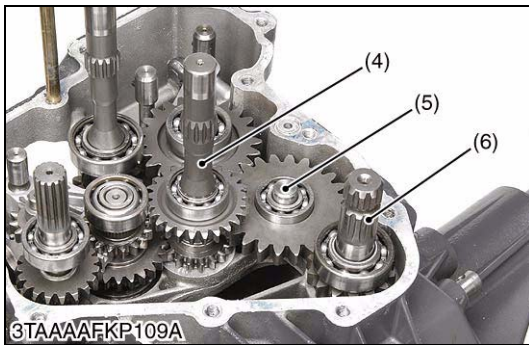
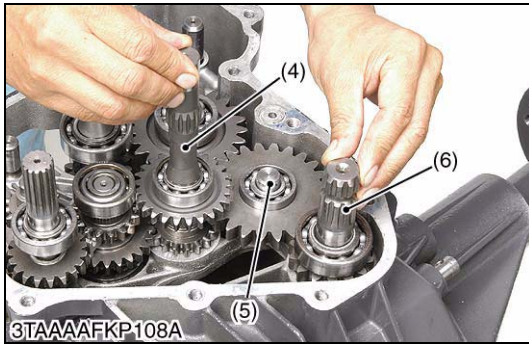

[4] SERVICING

(1) Hydrostatic Transmission

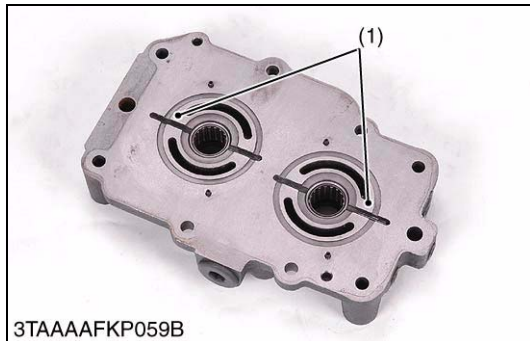

Center Section

1. Check the center section surface (1) for scratches or wear.
2. If deep scratch or excessive wear is found, replace the hydrostatic transmission assembly.

(1) Center Section Surface

W1093581

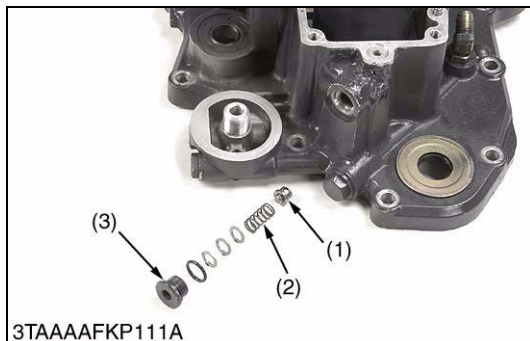

Charge Relief Valve

1. Check the charge relief valve (1) and the spring (2).
2. If defects are found, replace it.

(1) Charge Relief Valve (3) Plug
(2) Spring

W1093691

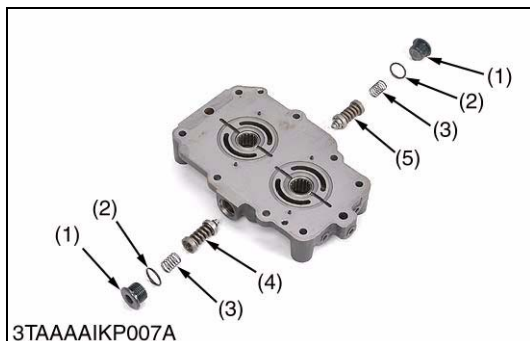

Check and High Pressure Relief Valve

1. Check the check and high pressure relief valve (4), (5) for scratches and damage.
2. Check the spring (3) for breakage and wear.
3. If anything are unusual, replace the check and high pressure relief valve as complete assembly.

NOTE

- Check and high pressure relief valve (reverse) has a pin hole (1.5 mm, 0.059 in.).

(1) Plug (4) Check and High Pressure Relief Valve (Forward)
(2) O-ring (5) Check and High Pressure Relief Valve (Reverse)
(3) Spring

W1093783

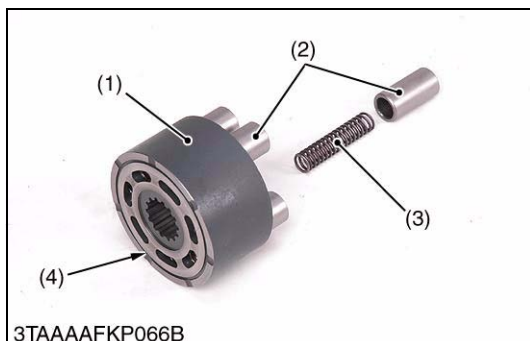

Cylinder Block Assembly

1. Check the cylinder blocks (1) and the pistons (2) for scratches and wear.
2. If there are scratch or worn, replace the cylinder block assembly.
3. Check the pistons for their free movement in the cylinder block bores.
4. If the piston or the cylinder block is scored, replace the cylinder block assembly.
5. Check the polished face (4) of the cylinder block for scoring. If it is scored, replace the cylinder block assembly.

IMPORTANT

- Do not interchange the pistons between the pump cylinder block and the motor cylinder block. Pistons and cylinder blocks are matched.

(1) Cylinder Block (3) Spring
(2) Piston (4) Polished Face

W1093936

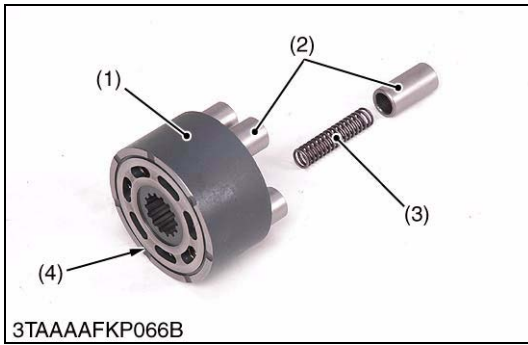

Cylinder Block Assembly

1. Check the cylinder blocks (1) and the pistons (2) for scratches and wear.
2. If there are scratch or worn, replace the cylinder block assembly.
3. Check the pistons for their free movement in the cylinder block bores.
4. If the piston or the cylinder block is scored, replace the cylinder block assembly.
5. Check the polished face (4) of the cylinder block for scoring. If it is scored, replace the cylinder block assembly.

■ IMPORTANT

- **Do not interchange the pistons between the pump cylinder block and the motor cylinder block. Pistons and cylinder blocks are matched.**

- (1) Cylinder Block
(2) Piston

- (3) Spring
(4) Polished Face

W1094117

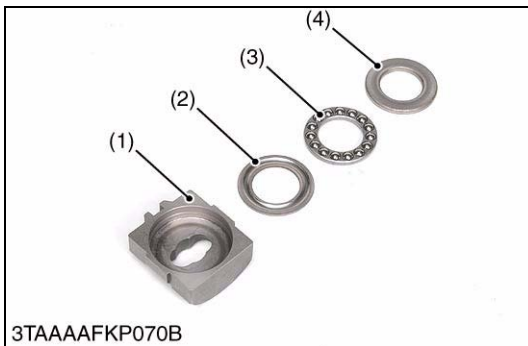

Thrust Washer, Thrust Roller Bearing, Thrust Plate and Cradle Bearing

1. Check the thrust bearing (3) for scratches and excessive wear.
2. If it is worn, replace it.
3. Check the thrust plate (4) for scratches and excessive wear. If it is worn or scored, replace it.
4. Check the cradle bearing (5) for excessive wear. If it is worn, replace it.

- (1) Swashplate
(2) Thrust Washer
(3) Thrust Bearing

- (4) Thrust Plate
(5) Cradle Bearing

W1094264

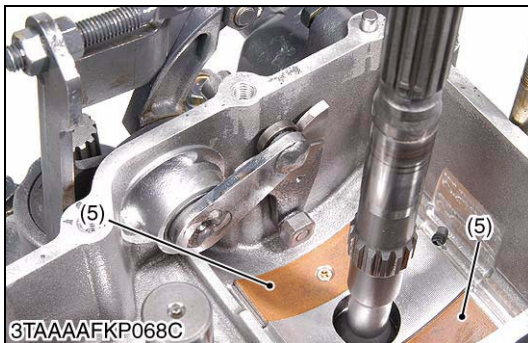

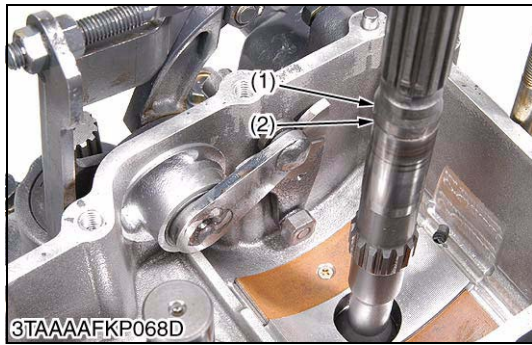

3TAAAFKP068D

Pump Shaft (PTO Clutch Shaft)

1. Check the seal surface (1) and the bearing surface.
2. If the pump shaft is rough or grooved, replace it.
3. If the ball bearing or the needle bearing is worn, replace it.

(1) Seal Surface (2) Bearing Surface

W1094465

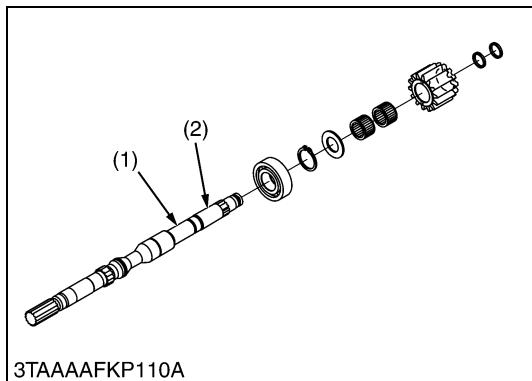

3TAAAFKP110A

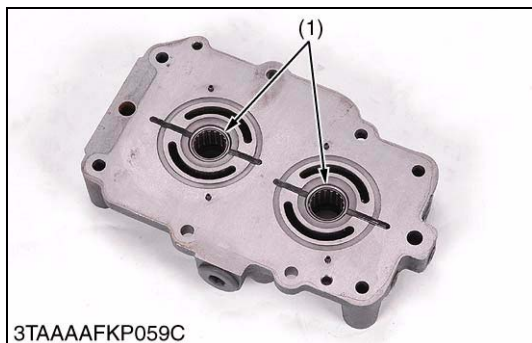

3TAAAFKP059C

Needle Bearing

1. Check the needle bearing (1) for wear.
2. If the needle bearing (1) are worn, replace them.

(1) Needle Bearing

W1094709

(2) Transaxle Case

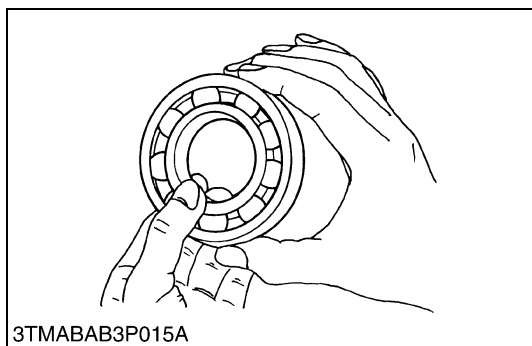

3TMABAB3P015A

Bearing

1. Hold the inner race, and push and pull the outer race in all directions to check wear and roughness.
2. Apply the transmission oil to the bearing, and hold the inner race. And turn the outer race to check rotation.
3. If there are any defect, replace the bearing.

W1094849

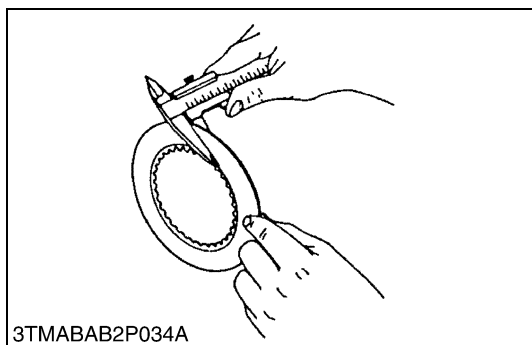

3TMABAB2P034A

PTO Clutch Disc Wear

1. Measure the thickness of PTO clutch disc with vernier calipers.
2. If the thickness is less than the allowable limit, replace it.

Thickness of PTO clutch disc	Factory spec.	1.50 to 1.70 mm 0.0591 to 0.0669 in.
	Allowable limit	1.35 mm 0.0531 in.

W1024320

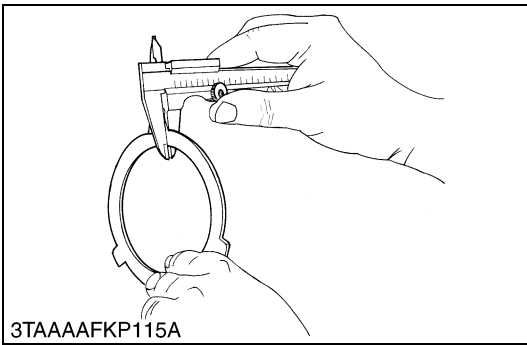

Separate Plate and Back Plate Wear

1. Measure the thickness of pressure plate and steel back with vernier calipers.
2. If the thickness is less than the allowable limit, replace it.

Thickness of separate plate	Factory spec.	0.9450 to 1.055 mm 0.03721 to 0.04153 in.
	Allowable limit	0.80 mm 0.031 in.

Thickness of back plate	Factory spec.	1.9 to 2.1 mm 0.075 to 0.082 in.
	Allowable limit	1.85 mm 0.0728 in.

W1017226

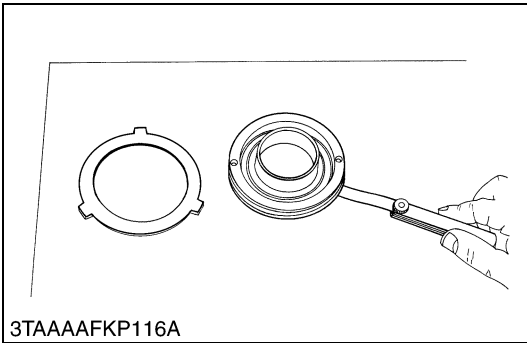

Flatness of Clutch Piston, Pressure Plate and Steel Plate

1. Place the part on a surface plate.
2. Check the flatness by inserting a feeler gauge (allowable limit size) underneath it at least four points.
3. If the gauge can be inserted, replace it.

Flatness of clutch piston	Allowable limit	0.15 mm 0.0059 in.
---------------------------	-----------------	-----------------------

Flatness of pressure plate and steel plate	Allowable limit	0.20 mm 0.0079 in.
--	-----------------	-----------------------

W1017358

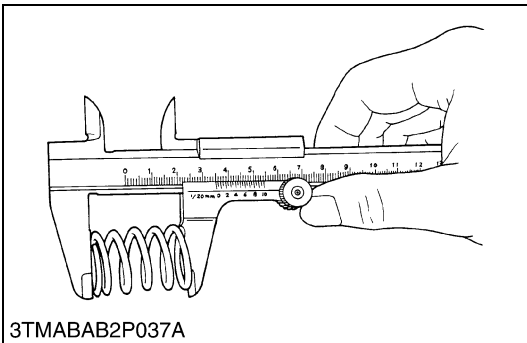

Clutch Spring Free Length

1. Measure the free length of spring with vernier calipers.
2. If the measurement is less than the allowable limit, replace it.

Clutch spring free length	Factory spec.	38.5 mm 1.52 in.
	Allowable limit	34.5 mm 1.36 in.

W1017533

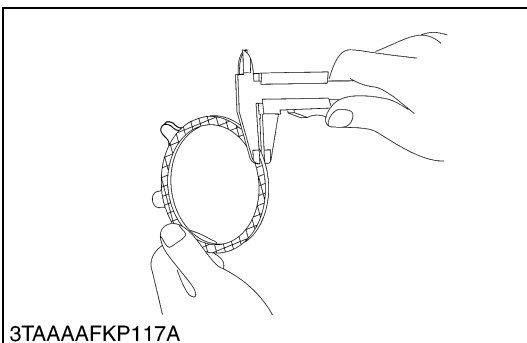

PTO Brake Disc Wear

1. Measure the PTO brake disc thickness with a vernier caliper.
2. If the thickness is less than allowable limit, replace it.

PTO brake disc thickness	Factory spec.	2.90 to 3.10 mm 0.115 to 0.122 in.
	Allowable limit	2.70 mm 0.11 in.

W1029590

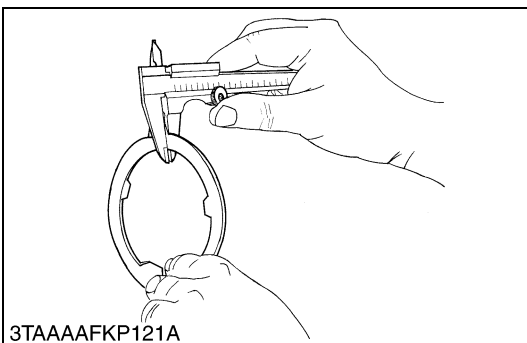

PTO Brake Plate

1. Measure the PTO brake plate thickness with a vernier caliper.
2. If the thickness is less than allowable limit, replace it.

PTO brake plate thickness	Factory spec.	1.9 to 2.1 mm 0.075 to 0.082 in.
	Allowable limit	1.85 mm 0.0728 in.

W1095464

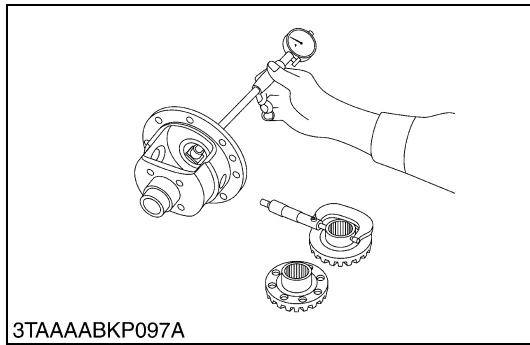

Clearance between Differential Case and Differential Side Gear

1. Measure the differential side gear boss O.D. with an outside micrometer.
2. Measure the differential case I.D. with a cylinder gauge and calculate the clearance.
3. If the clearance exceeds the allowable limit, replace faulty parts.

Clearance between differential case and differential side gear	Factory spec.	0.0500 to 0.151 mm 0.00197 to 0.00594 in.
	Allowable limit	0.30 mm 0.012 in.

Differential case I.D.	Factory spec.	38.000 to 38.062 mm 1.4961 to 1.4985 in.
Differential side gear O.D.	Factory spec.	37.911 to 37.950 mm 1.4926 to 1.4940 in.

W1029693

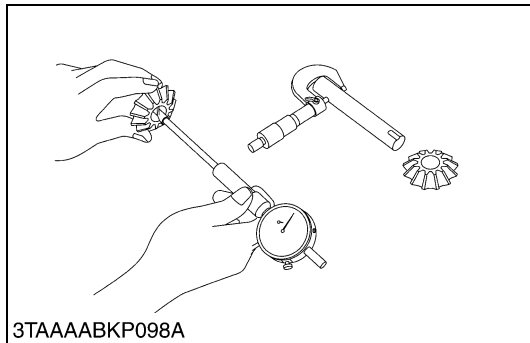

Clearance between Differential Pinion Shaft and Differential Pinion

1. Measure the differential pinion shaft O.D. with an outside micrometer.
2. Measure the differential pinion I.D. with a cylinder gauge, and calculate the clearance.
3. If the clearance exceeds the allowable limit, replace faulty parts.

Clearance between differential pinion shaft and differential pinion	Factory spec.	0.0800 to 0.122 mm 0.00315 to 0.00480 in.
	Allowable limit	0.30 mm 0.012 in.

Differential pinion I.D.	Factory spec.	20.060 to 20.081 mm 0.78977 to 0.79059 in.
Differential pinion shaft O.D.	Factory spec.	19.959 to 19.980 mm 0.78579 to 0.78661 in.

W1029832

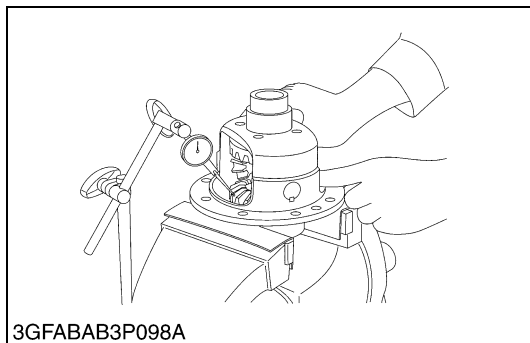

Backlash between Differential Pinion and Differential Side Gear

1. Secure the differential case with a vise.
2. Set the dial indicator (lever type) with its finger on the tooth of the differential side gear.
3. Press differential pinion and side gear against the differential case.
4. Hold the differential pinion and move the differential side gear to measure the backlash.
5. If the backlash exceeds the allowable limit, adjust with differential side gear shims.

Backlash between differential pinion and differential side gear	Factory spec.	0.15 to 0.30 mm 0.0059 to 0.011 in.
	Allowable limit	0.40 mm 0.016 in.

(Reference)

- Thickness of shims :
1.5 mm (0.059 in.), 1.6 mm (0.063 in.), 1.7 mm (0.067 in.)

W1029971

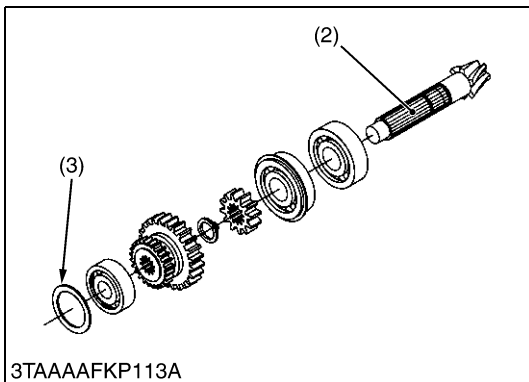
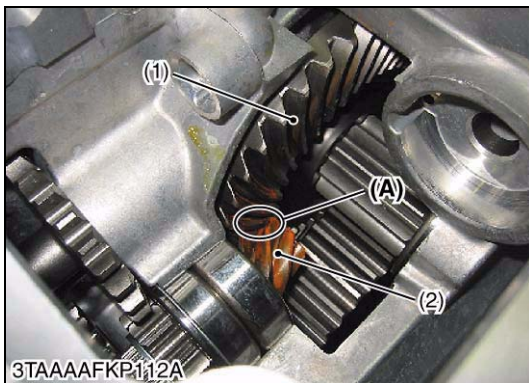

Backlash between Spiral Bevel Pinion Gear and Bevel Gear

1. Temporarily assemble the spiral bevel pinion gear (2) and the bevel gear (1) in the transaxle case.
2. Prepare the fuse bent already three to four times.
3. Hold the fuse on the bevel gear teeth upper surface (A).
4. Turn the front drive shaft one turn clockwise by hands.
5. Measure the thickness of the fuse as a backlash between the spiral bevel pinion gear and the bevel gear.
6. If the backlash exceeds the factory specifications, adjust the shims (3), (4).

Backlash between spiral bevel pinion and bevel gear	Factory spec.	0.10 to 0.30 mm 0.0040 to 0.011 in.
---	---------------	--

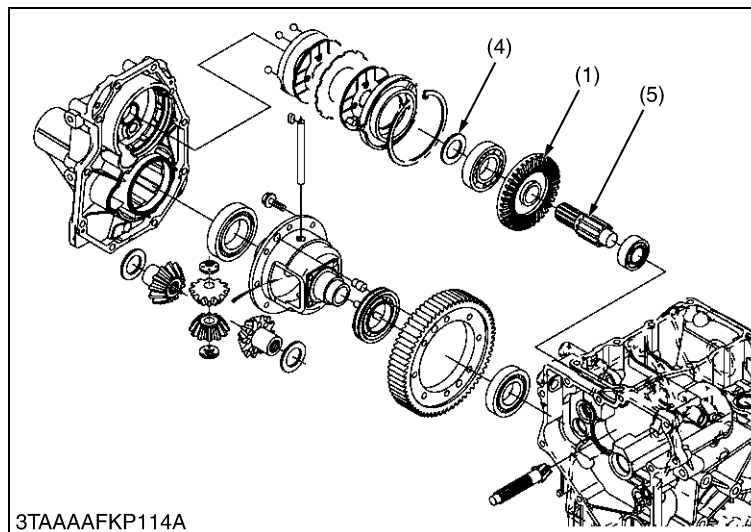

- (1) Bevel Gear
 - (2) Spiral Bevel Pinion Gear
 - (3) Shim
 - (4) Shim
 - (5) Final Gear Shaft (Brake Shaft)
- (A) Bevel Gear Teeth Upper Surface

W1095931

Brake Cam Lever Movement

1. Move the brake cam lever by hand to check its movement.
2. If its movement is heavy, refine the brake cam with a emery paper.

W1096217

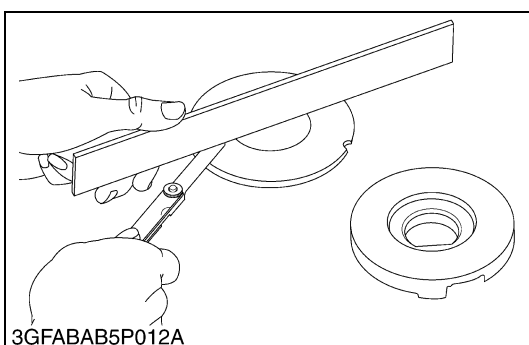

Flatness of Actuator and Bearing Holder

1. Place a straightedge of 150 mm (5.91 in.) or more in length on the contacting surface of the actuator and the bearing holder.
2. Inspect the friction surface of the actuator and the bearing holder with the straightedge, and determine if a 0.30 mm (0.0118 in.) feeler gauge will fit on the part of wear.
3. If it will fit, resurface.

Flatness of actuator and bearing holder	Allowable limit	0.30 mm 0.0118 in.
---	-----------------	-----------------------

W1030671

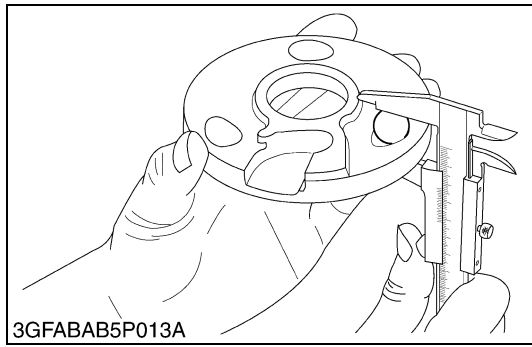

Height of Cam Plate and Ball

1. Measure the height of the cam plate with the ball installed.
2. If the measurement is less than the allowable limit, replace the cam plate and balls.
3. Inspect the ball holes of cam plate for uneven wear.
4. If the uneven wear is found, replace it.

Height of cam plate and ball	Factory spec.	22.89 to 22.99 mm 0.9012 to 0.9051 in.
	Allowable limit	22.40 mm 0.8819 in.

W1030769

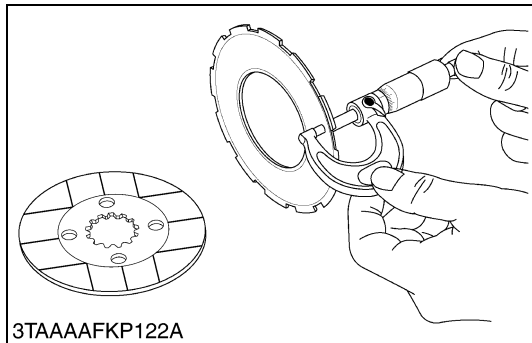

Brake Disc and Friction Plate Wear

1. Measure the brake disc thickness and the friction plate thickness with an outside micrometer.
2. If the thickness is less than the allowable limit, replace it.

Brake disc thickness	Factory spec.	3.30 to 3.50 mm 0.130 to 0.137 in.
	Allowable limit	3.0 mm 0.12 in.

Friction plate thickness	Factory spec.	1.92 to 2.08 mm 0.0756 to 0.0818 in.
	Allowable limit	1.52 mm 0.0598 in.

W1030890

3 FRONT AXLE

MECHANISM

CONTENTS

1. STRUCTURE	3-M1
2. FRONT WHEEL ALIGNMENT	3-M2

1. STRUCTURE

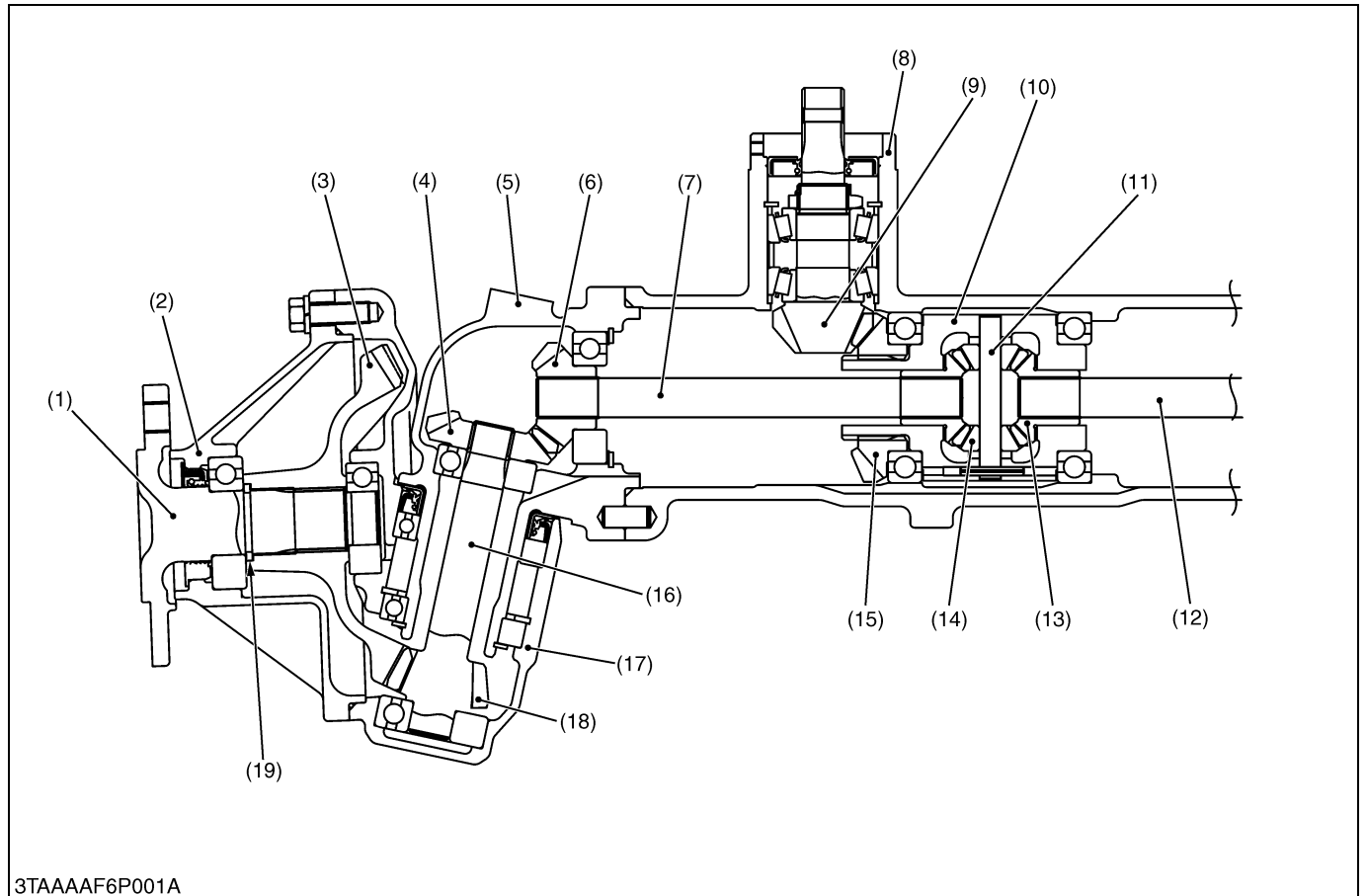

3TAAAF6P001A

- | | | | |
|---------------------|---------------------------------|----------------------------------|-----------------------|
| (1) Axle | (6) Bevel Gear | (11) Differential Pinion Shaft | (16) Bevel Gear Shaft |
| (2) Axle Flange | (7) Differential Yoke Shaft, RH | (12) Differential Yoke Shaft, LH | (17) Front Gear Case |
| (3) Bevel Gear | (8) Front Axle Case | (13) Differential Side Gear | (18) Bevel Gear |
| (4) Bevel Gear | (9) Bevel Pinion Shaft | (14) Differential Pinion Gear | (19) Collar |
| (5) Bevel Gear Case | (10) Differential Gear Assembly | (15) Bevel Gear | |

The front axle of the 4WD is constructed as shown above. Power is transmitted from the transmission through the propeller shaft to the bevel pinion shaft (9), then to the bevel gear (15) and to the differential side gear (13).

The power through the differential side gear is transmitted to the differential yoke shaft (7), (12), and to the bevel gear shaft (16) through the bevel gears (4), (6) in the bevel gear case (5).

The revolution is greatly reduced by the bevel gears (18), (3), then the power is transmitted to the axle (1).

The differential system allows each wheel to rotate at a different speed to make turning easier.

2. FRONT WHEEL ALIGNMENT

To assure smooth mobility or maneuverability and enhance stable and straight running, the front wheels are mounted at an angle to the right, left and forward directions. This arrangement is referred to as the Front Wheel Alignment.

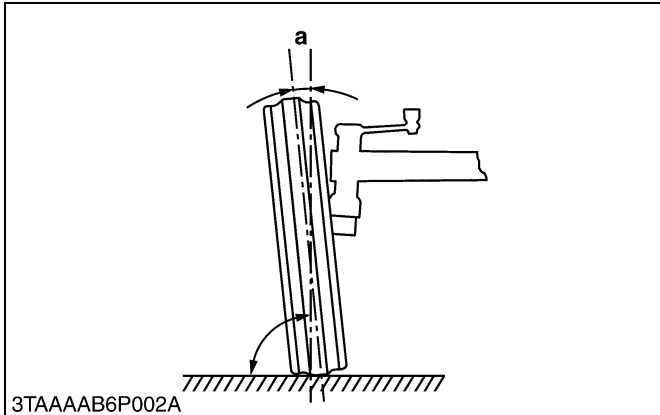

■ Camber

The front wheels are tilted from the vertical as viewed from the front, upper wheels are spreader than lower ones.

This inclination is called camber (a). Camber reduces bending or twisting of the front axle caused by vertical load or running resistance, and also maintains the stability in running.

Camber	0.035 rad 2 °
--------	------------------

W1012811

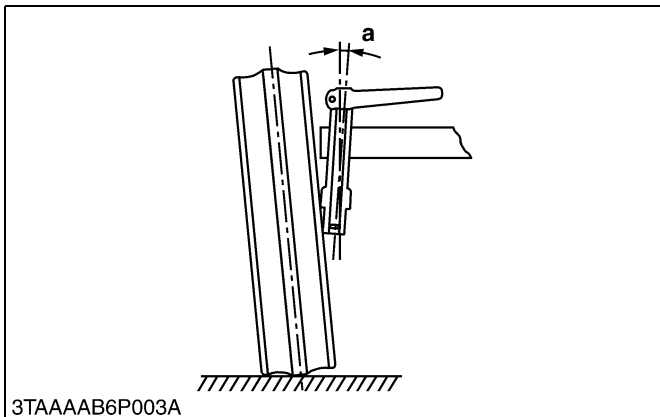

■ Kingpin Angle

The Kingpin is titled from the vertical as viewed from the front.

This angle is called kingpin angle (a). As with the camber, kingpin angle reduces rolling resistance of the wheels, and prevents any shimmy motion of the steering wheel.

It also reduces steering effort.

Kingpin angle	0.209 rad 12 °
---------------	-------------------

W1013073

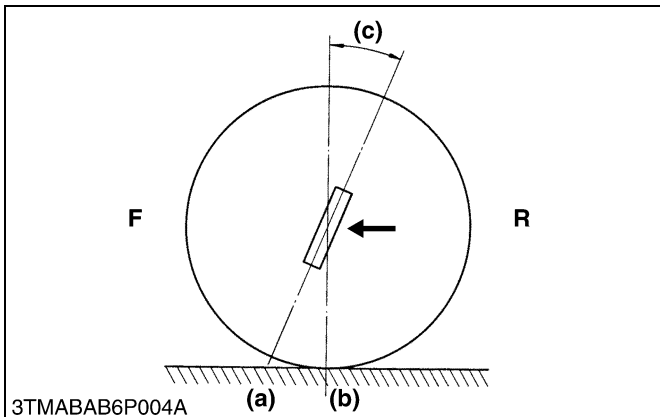

■ Caster

The kingpin is titled forward as viewed from the side. The point (b) of the wheel center line is behind the point (a) of the kingpin shaft center line.

This inclination is called caster (c). Caster helps provide steering stability.

As with the kingpin inclination, caster reduces steering effort.

Camber	0 rad 0 °
--------	--------------

F : Front

R : Rear

W1013142

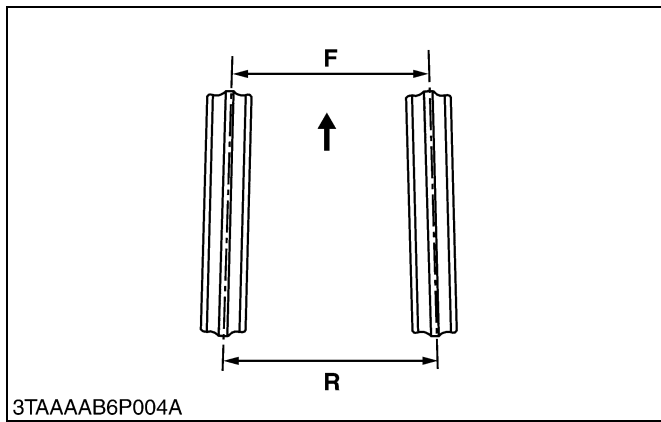

■ **Toe-in**

Viewing the front wheels from above reveals that the distance between the toes of the front wheels is smaller than that between the heels.

It is called toe-in. The front wheels tend to roll outward due to the camber, but toe-in offsets it and ensures parallel rolling of the front wheels. Another purpose of toe-in is to prevent excessive and uneven wear of tires.

Toe-in	0 to 5 mm 0 to 0.19 in.
--------	----------------------------

F : Front

R : Rear

W1013242

SERVICING

CONTENTS

1. TROUBLESHOOTING	3-S1
2. SERVICING SPECIFICATIONS	3-S2
3. TIGHTENING TORQUES	3-S3
4. CHECKING, DISASSEMBLING AND SERVICING.....	3-S4
[1] CHECKING AND ADJUSTING	3-S4
[2] PREPARATION	3-S5
(1) Separating Front Axle Assembly.....	3-S5
[3] DISASSEMBLING AND ASSEMBLING.....	3-S8
(1) Front Axle Assembly	3-S8
[4] SERVICING	3-S12

1. TROUBLESHOOTING

Symptom	Probable Cause	Solution	Reference Page
Front Wheels Wander to Right or Left	Tire pressure uneven	Adjust	G-41
	Improper toe-in adjustment (improper alignment)	Adjust	G-23, 3-S4
	Clearance between center pin and pin support bushing excessive	Replace	3-S14
	Front axle rocking force too small	Adjust	3-S4
	Tie-rod end loose	Tighten	4-S8
	Air sucked in power steering circuit	Bleed	–
Front Wheels Can Not Be Driven	Front wheel driving gears in front axle gear case broken	Replace	3-S11
	Universal joint broken	Replace	3-S7
	Front wheel drive gears in transmission broken	Replace	–
	Front differential gear broken	Replace	3-S13, S14
Noise	Gear backlash excessive	Adjust or replace	3-S12, S13
	Oil insufficient	Replenish	3-S5
	Bearings damaged or broken	Replace	–
	Gears damaged or broken	Replace	–
	Spiral bevel pinion shaft turning force improper	Adjust	3-S13

W1014322

2. SERVICING SPECIFICATIONS

Item		Factory Specification	Allowable Limit
Front Wheel Alignment	Toe-in	0 to 5 mm 0 to 0.2 in.	–
Front Axle	Rocking Force	49.1 to 117 N 5.00 to 12.0 kgf 11.1 to 26.4 lbf	–
Differential Case to Differential Side Gear	Clearance	0.040 to 0.082 mm 0.0016 to 0.0032 in.	0.17 mm 0.0067 in.
Differential Case	I.D.	26.000 to 26.021 mm 1.0237 to 1.0244 in.	–
Differential Side Gear	O.D.	25.939 to 25.960 mm 1.0213 to 1.0220 in.	–
Differential Pinion Shaft to Differential Pinion	Clearance	0.025 to 0.055 mm 0.0009 to 0.0021 in.	0.25 mm 0.0098 in.
Differential Pinion Shaft	O.D.	9.960 to 9.975 mm 0.3922 to 0.3927 in.	–
Differential Pinion	I.D.	10.000 to 10.015 mm 0.39370 to 0.39429 in.	–
Differential Pinion to Differential Side Gear	Backlash	0.1 to 0.3 mm 0.004 to 0.01 in.	–
Bevel Pinion Shaft	Turning Torque	0.80 to 1.0 N·m 0.082 to 0.10 kgf·m 0.59 to 0.73 lbf·ft	–
Bevel Pinion Shaft to Bevel Gear	Backlash	0.1 to 0.3 mm 0.004 to 0.01 in.	–
12T Bevel Gear to 15T Bevel Gear	Backlash	0.1 to 0.3 mm 0.004 to 0.01 in.	–
Center Pin to Pin Support Bushing	Clearance	0 to 0.231 mm 0 to 0.00909 in.	0.70 mm 0.028 in.
Center Pin	O.D.	19.850 to 20.000 mm 0.78150 to 0.78740 in.	–
Bushing	I.D.	20.000 to 20.081 mm 0.78741 to 0.79059 in.	–

W1016639

3. TIGHTENING TORQUES

Tightening torques of screws, bolts and nuts on the table below are especially specified.
(For general use screws, bolts and nuts : See page G-9.)

Item	N·m	kgf·m	lbf·ft
Front wheel mounting screw	149 to 179	15.2 to 18.3	110 to 132
Front wheel mounting screw	149 to 179	15.2 to 18.3	110 to 132
Tie-rod slotted nut	18 to 34	1.8 to 3.5	13 to 25
Power steering cylinder mounting screw	48 to 55	4.9 to 5.7	36 to 41
Power steering cylinder hose	24 to 27	2.4 to 2.8	18 to 20
Bevel gear case mounting screw (M10)	48 to 55	4.9 to 5.7	36 to 41
Bevel gear case mounting screw (M12)	78 to 90	7.9 to 9.2	58 to 66
Front gear case cover mounting screw	48 to 55	4.9 to 5.7	36 to 41

W1012736

4. CHECKING, DISASSEMBLING AND SERVICING

[1] CHECKING AND ADJUSTING

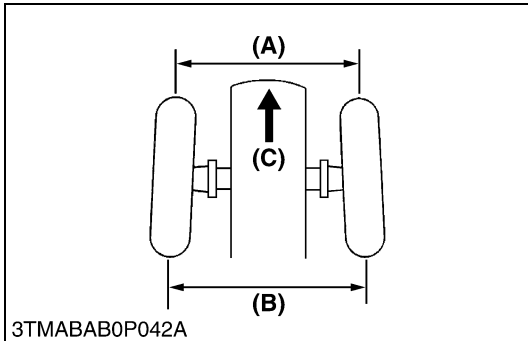

Toe-in

1. Inflate the tires to the specified pressure.
2. Turn the front wheels straight ahead.
3. Measure the toe-in ((B) - (A)).
4. If the measurement is not within the factory specifications, adjust the tie-rod length.

Toe-in ((B) - (A))	Factory spec.	0 to 5 mm 0 to 0.2 in.
--------------------	---------------	---------------------------

Adjusting procedure

1. Loosen the lock nuts and turn the tie-rod to adjust the rod length until the proper toe-in measurement is obtained.
2. Retighten the lock nuts.

- (1) Tie-rod
- (2) Lock Nut

- (A) Wheel to Wheel Distance at Front
- (B) Wheel to Wheel Distance at Rear
- (C) Front

W1011333

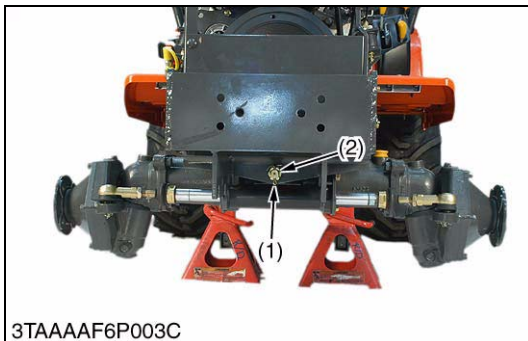
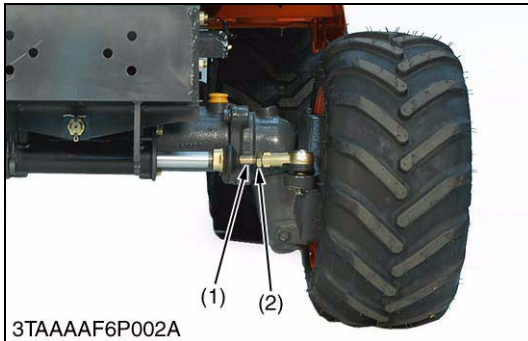

Front Axle Rocking Force

1. Jack up the front side of tractor and remove the front wheel.
2. Set a spring balance to the front gear case cover.
3. Measure the front axle rocking force.
4. If the measurement is not within the factory specifications, adjust as following.

Adjusting procedure

1. Remove the cotter pin (1).
2. Tighten or loosen the adjusting nut (2) so that the measurement of rocking force comes to factory specifications.
3. If the slot and pin hole do not meet, align the nut until they do meet within factory specifications.
4. Install the new cotter pin.

(When reassembling)

- Be sure to split the cotter pin like an anchor.

(Reference)

- Tightening torque of adjusting nut:
20 N·m (2.0 kgf·m, 14 lbf·ft)

Front axle rocking force	Factory spec.	49.1 to 177 N 5.00 to 12.0 kgf 11.1 to 26.4 lbf
--------------------------	---------------	---

- (1) Cotter Pin

- (2) Adjusting Nut

W1011602

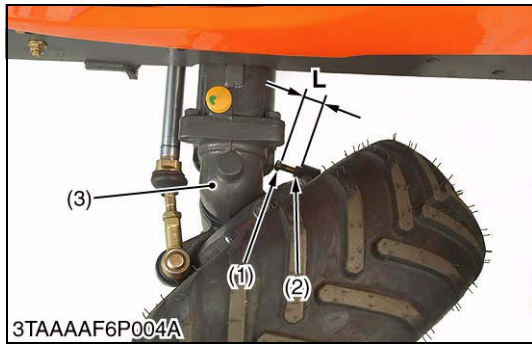

Front Wheel Steering Angle

1. Inflate the tires to the specified pressure.
2. Loosen the lock nut and shorten the length of stopper bolt LH (1).
3. Steer the wheels to the extreme left.
4. Lengthen the length of stopper bolt (1) until the stopper bolt contacts with the bevel gear case (3).
5. Return the steering wheel to straight ahead and lengthen the stopper bolt four turn from above position further.
6. Lock the stopper bolt by lock nut (2).
7. For adjusting the right steering angle, perform the same procedure as mentioned in left steering angle.

(Reference)

Steering angle	Right side	0.84 to 0.87 rad 48 to 50 °
	Left side	0.93 to 0.95 rad 53 to 55 °

Length of adjusting bolt (L)	Right side	26 mm 1.0 in.
	Left side	21 mm 0.83 in.

- (1) Stopper Bolt LH (2) Lock Nut (3) Bevel Gear Case

W1011846

[2] PREPARATION

(1) Separating Front Axle Assembly

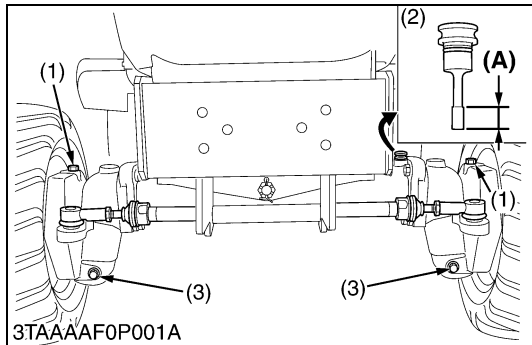

Draining Front Axle Case Oil

1. Place the oil pans underneath the front axle case.
2. Remove both right and left hand side drain plugs (3) and filling plug (2) to drain the oil.
3. After draining, reinstall the drain plugs (3).

(When reassembling)

- When re-filling, remove the right and left breather plugs (1).

■ IMPORTANT

- **After ten minutes, check the oil level again, add oil to prescribed level.**
- **Use KUBOTA SUPER UDT fluid or SAE80, 90 gear oil. Refer to "LUBRICANTS, FUEL AND COOLANT". (See page G-7.)**

Oil Capacity	BX1860	2.3 L 2.4 U.S.qts 2.0 Imp.qts
	BX2360 BX2660	4.7 L 5.0 U.S.qts 4.1 Imp.qts

- (1) Breather Plug (2) Filling Plug with Dipstick (3) Drain Plug

(A) Oil level is acceptable within this range.

W1012192



Battery

⚠ CAUTION

- When disconnecting the battery cables, disconnect the negative cable from the battery first. When connecting, connect the positive cable to the battery first.

1. Remove the under panel (1).
2. Disconnect the negative cable (2) from the battery.

- (1) Under Panel
- (2) Battery
- (3) Negative Cable

W1012394



Bonnet and Under Cover

1. Open the bonnet (1), disconnect the connectors (3) for the head lights, then remove the bonnet with the bonnet bracket (4).
2. Remove the under cover (2).

- (1) Bonnet
- (2) Under Cover
- (3) Connector
- (4) Bonnet Bracket

W1012507

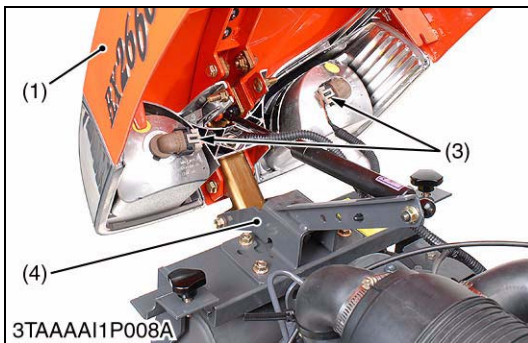

Front Wheel and Propeller Shaft Cover

1. Lift up the front of tractor and place the disassembling stand under the front axle frame.
2. Remove the front wheels.
3. Remove the propeller shaft cover mounting bolt and slide the propeller shaft cover (1).

(When reassembling)

Tightening torque	Front wheel mounting screw	149 to 179 N·m 15.2 to 18.3 kgf·m 110 to 132 lbf·ft
-------------------	----------------------------	---

- (1) Propeller Shaft Cover

W1012838

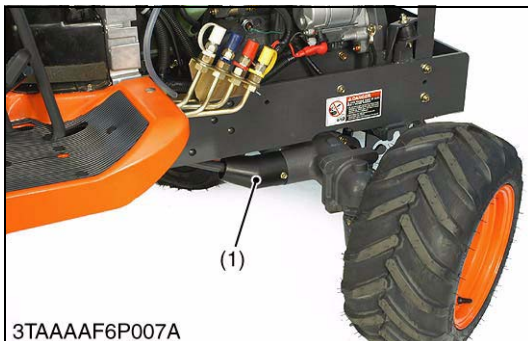

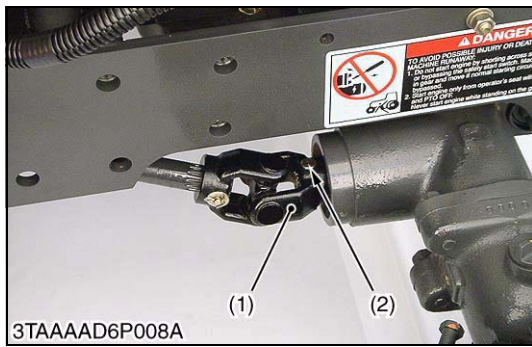

Disconnecting Propeller Shaft

1. Tap out the spring pins (2) and disconnect the universal joint (1) and spiral bevel pinion shaft.

(When reassembling)

- Apply grease to the splines of the propeller shaft and universal joint.

(1) Universal Joint

(2) Spring Pin

W1013075

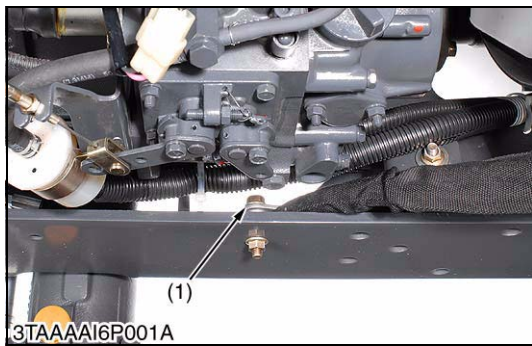

Front Axle Assembly

1. Remove the power steering hose clamp (1).
2. Place the garage jack under the front axle.
3. Remove the cotter pin (1).
4. Remove the slotted nut (2) of center pin and separate the front axle from the frame.
5. Disconnect the power steering cylinder hoses (4).

(When reassembling)

- After mounting the front axle assembly to the frame, be sure to adjust the front axle rocking force. (See page 3-S4.)
- Installing the cotter pin, be sure to split the cotter pin like an anchor

Tightening torque	Power steering cylinder hose	24 to 27 N·m 2.4 to 2.8 kgf·m 18 to 20 lbf·ft
-------------------	------------------------------	---

(1) Hose Clamp

(2) Cotter Pin

(3) Slotted Nut (Adjusting Nut for Front Axle Rocking Force)

(4) Power Steering Hose

W1023380

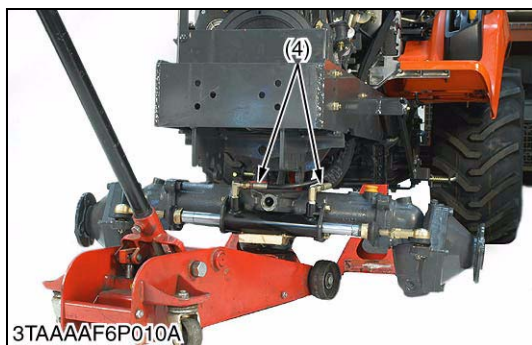
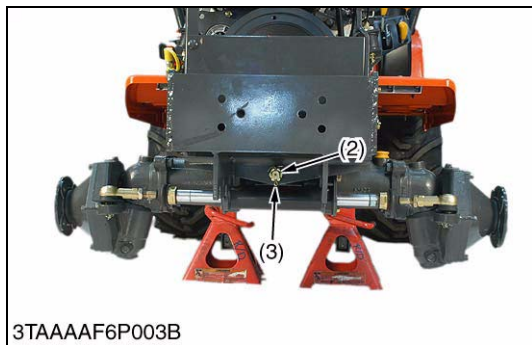

[3] DISASSEMBLING AND ASSEMBLING

(1) Front Axle Assembly

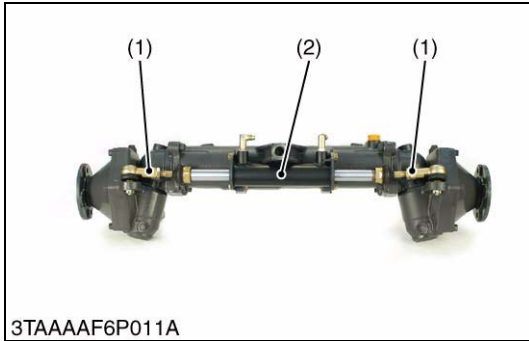

Power Steering Cylinder

1. Remove the cotter pin and remove the slotted nut for tie-rod (1).
2. Remove the power steering cylinder mounting screws and remove the power steering cylinder (2) with tie-rod.

(When reassembling)

■ NOTE

- Tighten the slotted nut to 18 N·m (1.8 kgf·m, 13 lbf·ft). If the slot and pin hole do not meet, tighten the nut until they do meet, and install the cotter pin.
- Be sure to split the cotter pin like an anchor.

Tightening torque	Tie-rod slotted nut	18 to 34 N·m 1.8 to 3.5 kgf·m 13 to 25 lbf·ft
	Power steering cylinder mounting screw	48 to 55 N·m 4.9 to 5.7 kgf·m 36 to 41 lbf·ft

(1) Tie-rod

(2) Power Steering Cylinder

W1013368

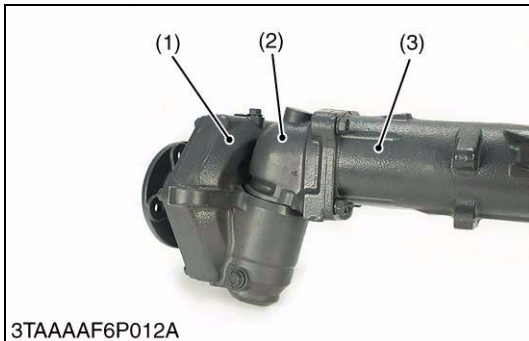

Bevel Gear Case and Front Gear Case

1. Remove the bevel gear case mounting screws.
2. Remove the bevel gear case (2) and front gear case (1) as a unit from the front axle case (3).

(When reassembling)

- Apply grease to the O-ring and take care not to damage it.
- Do not interchange right and left bevel gear case assemblies and right and left gear case assemblies.

Tightening torque	Bevel gear case mounting screw (M10)	48 to 55 N·m 4.9 to 5.7 kgf·m 36 to 41 lbf·ft
	Bevel gear case mounting screw (M12)	78 to 90 N·m 7.9 to 9.2 kgf·m 58 to 66 lbf·ft

(1) Front Gear Case

(3) Front Axle Case

(2) Bevel Gear Case

W1013787

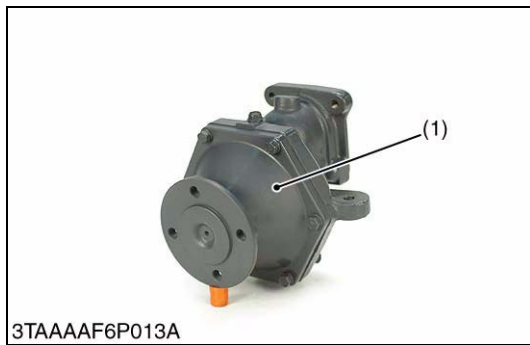

Front Gear Case Cover

1. Remove the front gear case mounting screws and remove the front gear case cover (1) with bevel gear (2).

(When reassembling)

- Apply grease to the O-ring and take care not to damage it.

Tightening torque	Front gear case cover mounting screw	48 to 55 N·m 4.9 to 5.7 kgf·m 36 to 41 lbf·ft
-------------------	--------------------------------------	---

- (1) Front Gear Case Cover (3) Front Gear Case
(2) Bevel Gear

W1013952

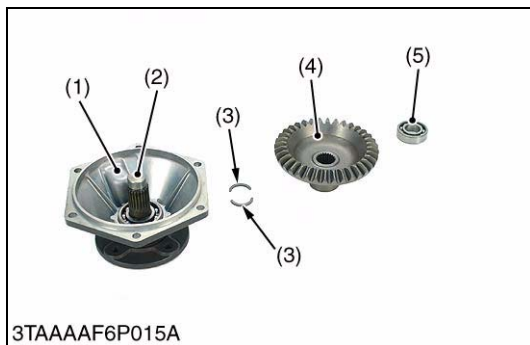
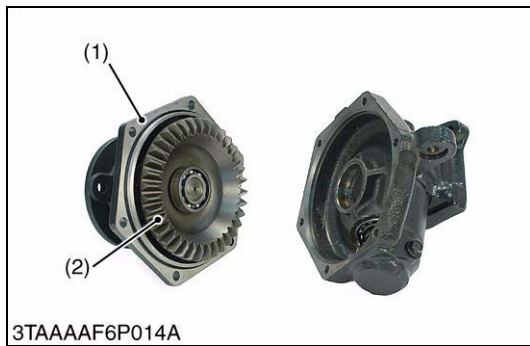

36T Bevel Gear and Front Axle Shaft

1. Remove the bearing (5).
2. Take out the 36T bevel gear (4).
3. Take out the collar (3).
4. Tap out the axle shaft (2).

(When reassembling)

- Install the oil seal (6) of front gear case cover (1), noting its direction as shown in the figure.

- (1) Front Gear Case Cover (4) 36T Bevel Gear
(2) Axle Shaft (5) Ball Bearing
(3) Collar (6) Oil Seal

W1014087

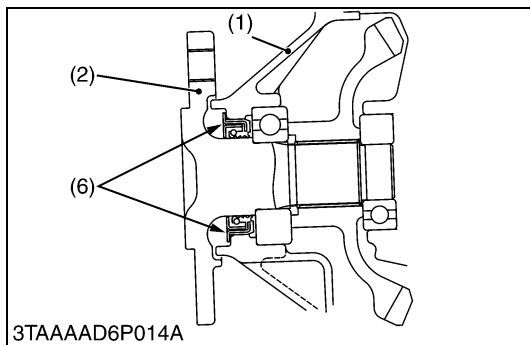

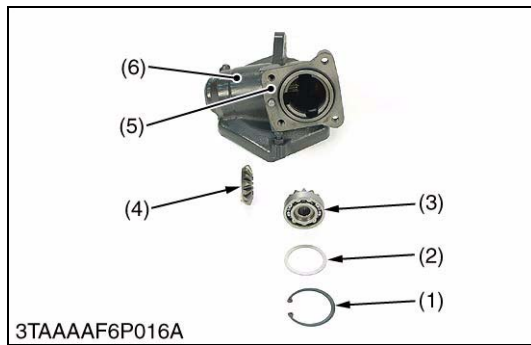

Front Gear Case and Bevel Gear Case

1. Remove the internal snap ring (1).
2. Remove the bevel gear with ball bearing (3) and shim (2).
3. Remove the bevel gear (4).
4. Remove the external snap ring (7).
5. Remove the bevel gear case (5) from front gear case (6).
6. Remove the oil seal (12) and the ball bearing (11).
7. Remove the internal snap ring (10) and remove the ball bearing (9).
8. Remove the bevel gear shaft (8) with ball bearing.

(When reassembling)

- Install the oil seal (12) of bevel gear case, noting its direction as shown in the figure.
- Install the adjusting shims (2) to their original position.

- | | |
|------------------------|-------------------------|
| (1) Internal Snap Ring | (8) Bevel Gear Shaft |
| (2) Shim | (9) Ball Bearing |
| (3) Ball Bearing | (10) Internal Snap Ring |
| (4) Bevel Gear | (11) Ball Bearing |
| (5) Bevel Gear Case | (12) Oil Seal |
| (6) Front Gear Case | (13) Ball Bearing |
| (7) External Snap Ring | |

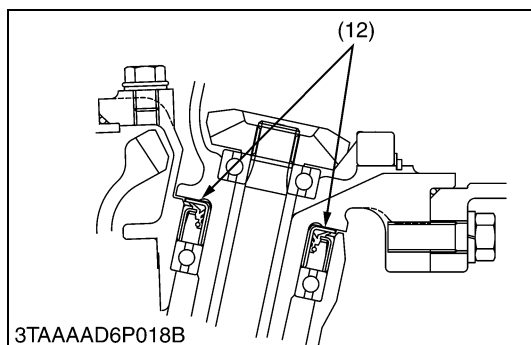
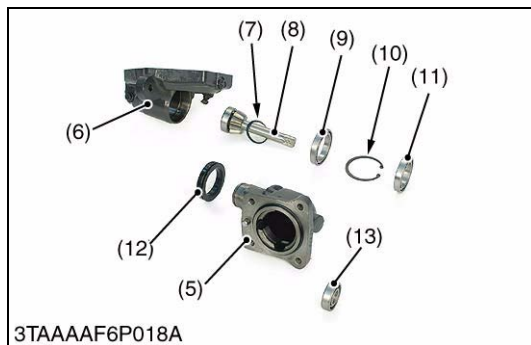
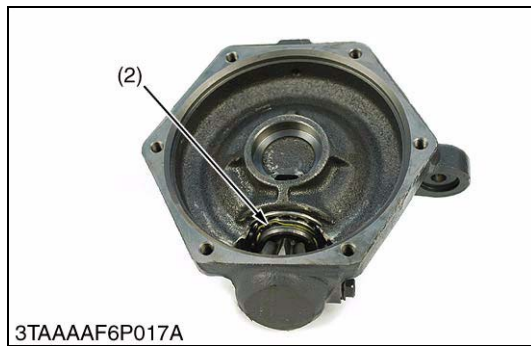

W1014354

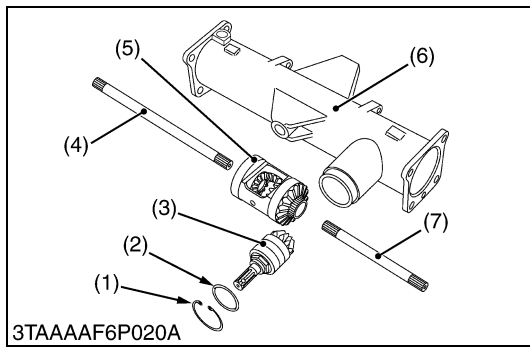

Bevel Pinion Shaft and Differential Gear Assembly

1. Take out the differential yoke shaft (4), (7).
2. Remove the oil seal (11).
3. Remove the internal snap ring (1).
4. Pull out the bevel pinion shaft (3).
5. Take out the differential gear assembly (5), from right side of front axle case (6).
6. Remove the stake of lock nut (10), and then remove the lock nut (10).
7. Remove the taper roller bearing (9).

(When reassembling)

- Apply gear oil to the taper roller bearings (9) and install them correctly, noting their direction.
- Replace the lock nut (10) and oil seal (11) with new ones.
- After tighten the lock nut (10) to the specified torque, stake it firmly.
- Install the adjusting collars (2), (8) to their original position.

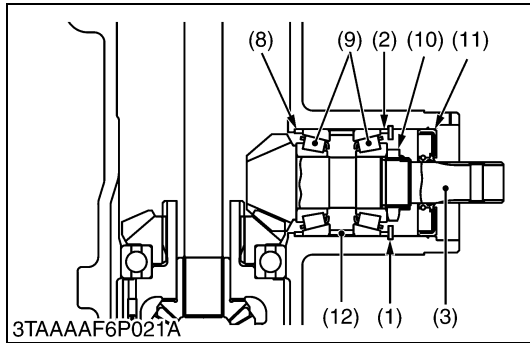

- | | |
|--------------------------------|--------------------------------|
| (1) Internal Snap Ring | (7) Differential Yoke Shaft RH |
| (2) Adjusting Collar | (8) Adjusting Collar |
| (3) Bevel Pinion Shaft | (9) Taper Roller Bearing |
| (4) Differential Yoke Shaft LH | (10) Lock Nut |
| (5) Differential Gear Assembly | (11) Oil Seal |
| (6) Front Axle Case | (12) Collar |

W1017911

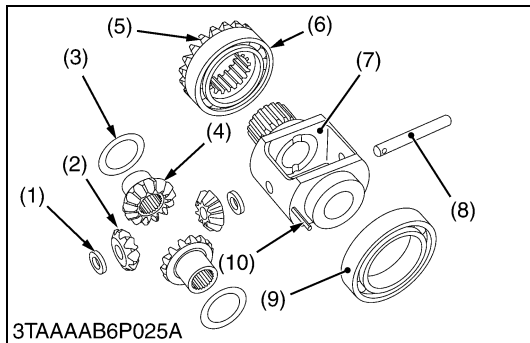

Differential Gear

1. Remove the bevel gear (5) with bearing (6) and bearing (9) by puller.
2. Remove the spring pin (10).
3. Remove the differential pinion shaft (8).
4. Remove the differential pinions (2), differential side gears (4) and shims (1), (3).

NOTE

- **Arrange the parts to know their original position.**

(When reassembling)

- Apply molybdenum disulfide (Three Bond 1901 or equivalent) to the inner circumferential surface of the differential side gears, differential pinions and shims.

- | | |
|----------------------------|-------------------------------|
| (1) Shim | (6) Bearing |
| (2) Differential Pinion | (7) Differential Gear Case |
| (3) Shim | (8) Differential Pinion Shaft |
| (4) Differential Side Gear | (9) Ball Bearing |
| (5) Bevel Gear | (10) Spring Pin |

W1028857

[4] SERVICING



3TAAAAD6P023A

Clearance between Differential Case and Differential Side Gear

1. Measure the differential side gear boss O.D..
2. Measure the differential case bore I.D., and calculate the clearance.
3. Measure the differential case cover bore I.D., and calculate the clearance.
4. If the clearance exceeds the allowable limit, replace faulty parts.

Clearance between differential case and differential side gear	Factory spec.	0.040 to 0.082 mm 0.0016 to 0.0032 in.
	Allowable limit	0.17 mm 0.0067 in.

Differential case bore I.D.	Factory spec.	26.000 to 26.021 mm 1.0237 to 1.0244 in.
Differential side gear O.D.		25.939 to 25.960 mm 1.0213 to 1.0220 in.

W1015523



3TAAAAD6P024A

Clearance between Differential Pinion Shaft and Differential Pinion

1. Measure the differential pinion shaft O.D..
2. Measure the differential pinion I.D., and calculate the clearance.
3. If the clearance exceeds the allowable limit, replace faulty parts.

Clearance between differential pinion shaft and differential pinion	Factory spec.	0.025 to 0.055 mm 0.00099 to 0.0021 in.
	Allowable limit	0.25 mm 0.0096 in.

Differential pinion shaft O.D.	Factory spec.	9.960 to 9.975 mm 0.3922 to 0.3927 in.
Differential side gear I.D.	Factory spec.	10.000 to 10.015 mm 0.39370 to 0.39429 in.

W1015675



3TAAAAD6P025A

Backlash between Differential Pinion and Differential Side Gear

1. Set a dial gauge (lever type) on a tooth of the differential pinion.
2. Fix the differential side gear, and move the differential pinion to measure the backlash.
3. If the measurement exceeds the factory specifications, adjust with the differential side gears shims.

Backlash between differential pinion and differential side gear	Factory spec.	0.1 to 0.3 mm 0.004 to 0.01 in.
---	---------------	------------------------------------

(Reference)

- Thickness of adjusting shims :
 - For side gear : 0.80 mm (0.031 in.), 1.0 mm (0.039 in.)
1.2 mm (0.047 in.)
 - For pinion : 3.30 mm (0.130 in.), 3.50 mm (0.138 in.)
3.70 mm (0.146 in.), 3.90 mm (0.154 in.)

W1015817

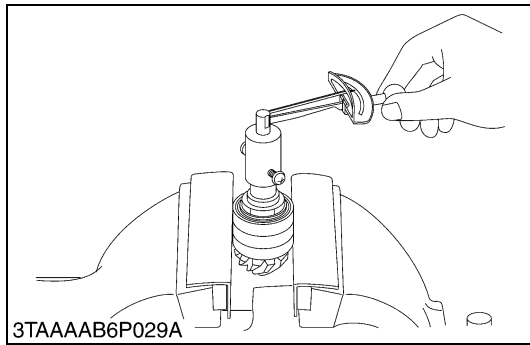

Turning Torque of Bevel Pinion Shaft

1. Cramp the spiral bevel pinion shaft assembly to the vise and tighten the staking nut.
2. Measure the turning torque of bevel pinion shaft.
3. If the turning torque is not within the factory specifications, adjust with the lock nut.

Turning torque	Factory spec.	0.8 to 1.0 N·m 0.082 to 0.10 kgf·m 0.59 to 0.73 lbf·ft
----------------	---------------	--

NOTE

- After turning force adjustment, be sure to stake the lock nut. W10206520

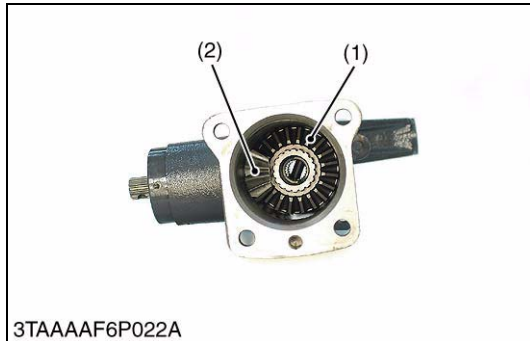

Backlash between Bevel Pinion Shaft and Bevel Gear

1. Put the solder (0.5 mm (0.02 in.) thickness) on the position where the tooth proper contact of bevel pinion shaft.
2. Fix the bevel gear and rotate the bevel pinion shaft carefully.
3. Measure the backlash by thickness of the point where solder is the thinnest.
4. If the backlash is not within the factory specifications, change the adjusting collars (3), shims (4). For example change the adjusting shim (4) to 0.1 mm (0.004 in.) smaller size, and change the adjusting collar (3) to 0.1 mm (0.004 in.) larger size.
5. Adjust the backlash properly by repeating the above procedures.

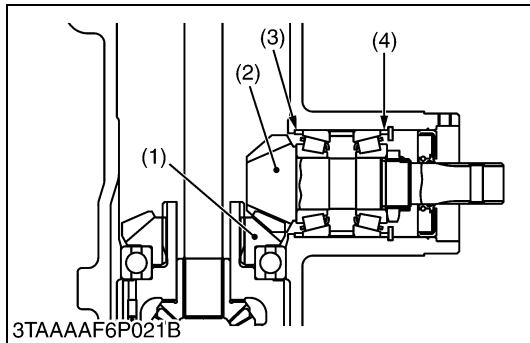

Backlash between bevel pinion shaft and bevel gear	Factory spec.	0.1 to 0.3 mm 0.004 to 0.01 in.
--	---------------	------------------------------------

(Reference)

- Thickness of adjusting collars (3), (4) :

3.40 mm (0.134 in.)	4.10 mm (0.161 in.)
3.60 mm (0.142 in.)	4.20 mm (0.165 in.)
3.80 mm (0.150 in.)	4.40 mm (0.173 in.)
3.90 mm (0.154 in.)	4.50 mm (0.177 in.)
4.00 mm (0.157 in.)	4.60 mm (0.181 in.)

- (1) Bevel Gear
- (2) Bevel Pinion Shaft
- (3) Adjusting Collar
- (4) Adjusting Collar

W10301800

4 STEERING

MECHANISM

CONTENTS

1. HYDRAULIC CIRCUIT.....	4-M1
2. STEERING CONTROLLER.....	4-M2
3. STEERING CYLINDER.....	4-M3

1. HYDRAULIC CIRCUIT

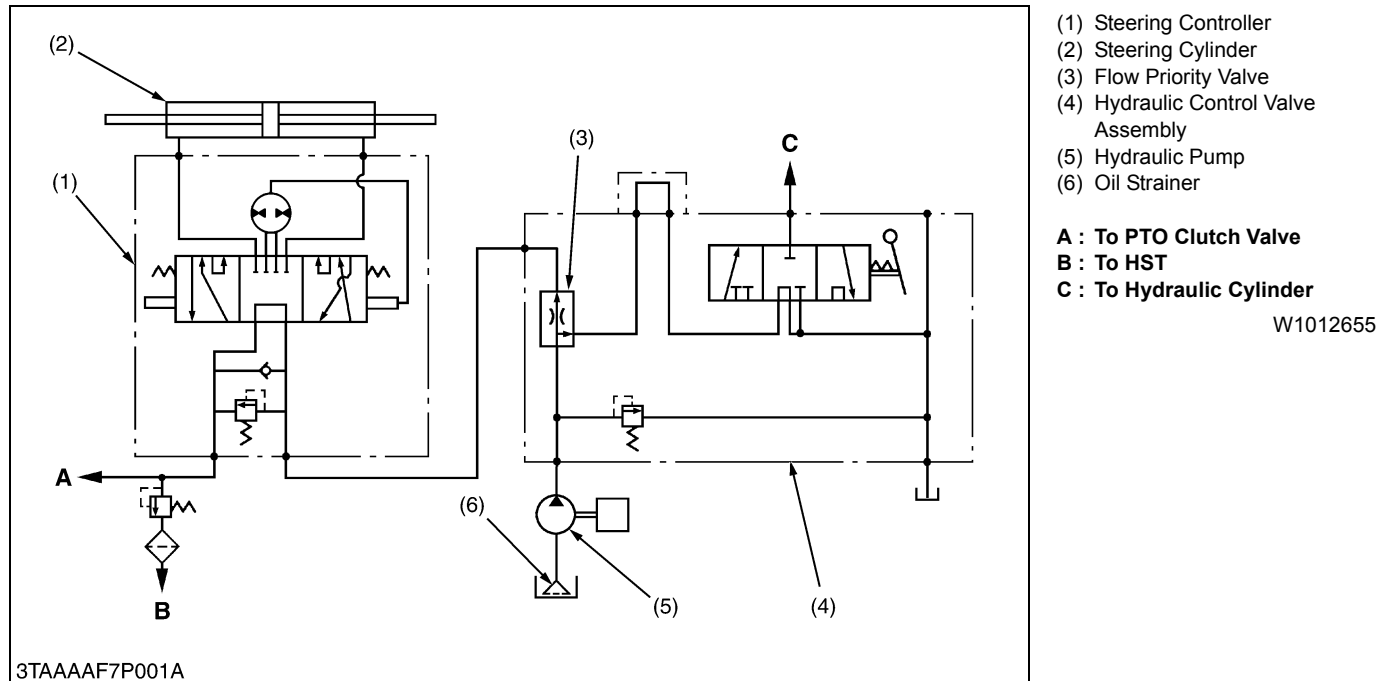

This model is provided with a full hydrostatic power steering.

In the full hydrostatic power steering, the steering controller is connected to the steering cylinder with only the hydraulic piping. Accordingly, it does not have mechanical transmitting parts such as steering gear, pitman arm, drag link, etc.. Therefore, it is simple in construction. This steering system consists of the oil strainer (6), hydraulic pump (5), flow priority valve (3), steering controller (1), steering cylinder (2), etc..

Flow priority valve (3) which located in the hydraulic control valve assembly (4) divides the oil into two direction. One is the control flow to power steering (constantly 9.5 L/min., 2.5 U.S.gals/min., 2.1 Imp.gals/min.), and the other is excessive flow to control valve of implement lift control.

By operating the power steering body, the required amount of oil is fed to the steering cylinder (2).

2. STEERING CONTROLLER

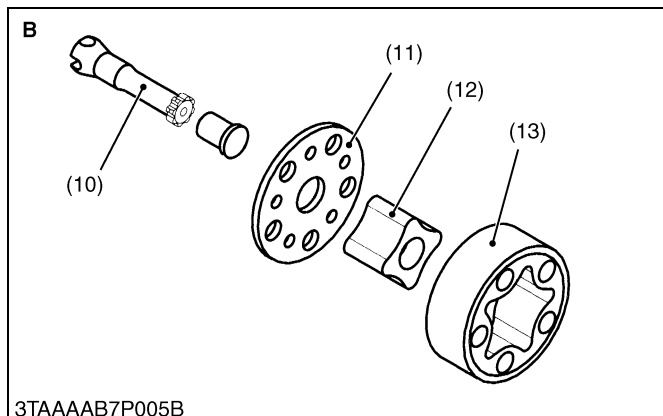
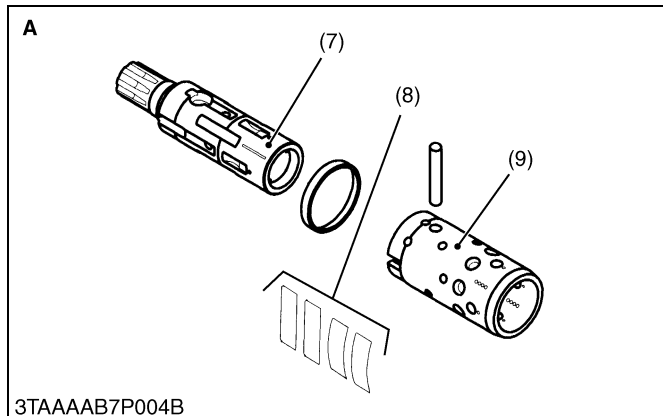
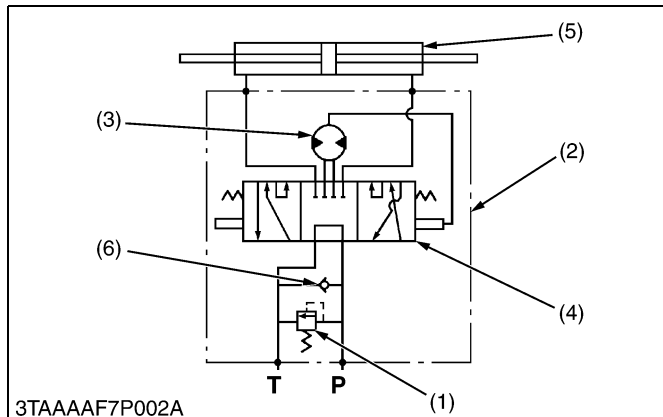
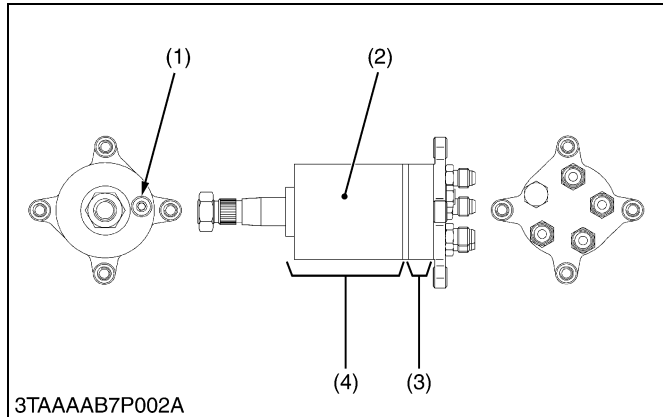

The steering controller consists of a control valve (4) and a metering device (3).

■ Control Valve

The control valve is a rotating spool type.

When the steering wheel is turned, the position of the spool (7) and sleeve (9) is kept neutral by the centering spring (8). This causes the forming of a "Neutral" oil circuit.

When the steering wheel is turned either clockwise or counterclockwise, the position of the spool and sleeve changes in relation to the centering spring. This allows the forming of a "Right Turning" or "Left Turning" oil circuit. At the same time, the gear pump (Metering device) rotates with the spool and sends the oil to the cylinder corresponding to the rotation of the steering wheel.

■ Metering Device

Oil sent from the hydraulic pump to the steering cylinder, passes through the metering device (3).

Namely, when the rotor is driven, two chambers suck in oil due to volumetric change in the pump chambers formed between the rotor (12) and the stator (13), while oil is discharged from other two chambers. On the other hand, rotation of the steering wheel is directly transmitted to the rotor through the spool (7), drive shaft (10), etc.

Accordingly, the metering device serves to supply the steering cylinder with oil, amount of which corresponds to the rotation of the steering wheel. The wheels are thus turned by the angle corresponding to the rotation of the steering wheel.

When the engine stops or the hydraulic pump malfunctions, the metering device functions as a manual trochoid pump, which makes manual steering possible.

■ Relief Valve

The relief valve (1) is located in the steering controller. It controls the maximum pressure of the power steering system.

Its setting pressure is as follows.

8.33 to 8.83 MPa

85 to 90 kgf/cm²

1209 to 1280 psi

- | | |
|-------------------------|------------------------|
| (1) Relief Valve | (10) Drive Shaft |
| (2) Steering Controller | (11) Distributor Plate |
| (3) Metering Device | (12) Rotor |
| (4) Control Valve | (13) Stator |
| (5) Steering Cylinder | |
| (6) Check Valve | |
| (7) Spool | |
| (8) Centering Spring | |
| (9) Sleeve | |

- A : Control Valve**
B : Metering Device
P : P Port (From flow priority valve)
T : T Port (To PTO clutch valve and HST circuit)

W1012783

3. STEERING CYLINDER

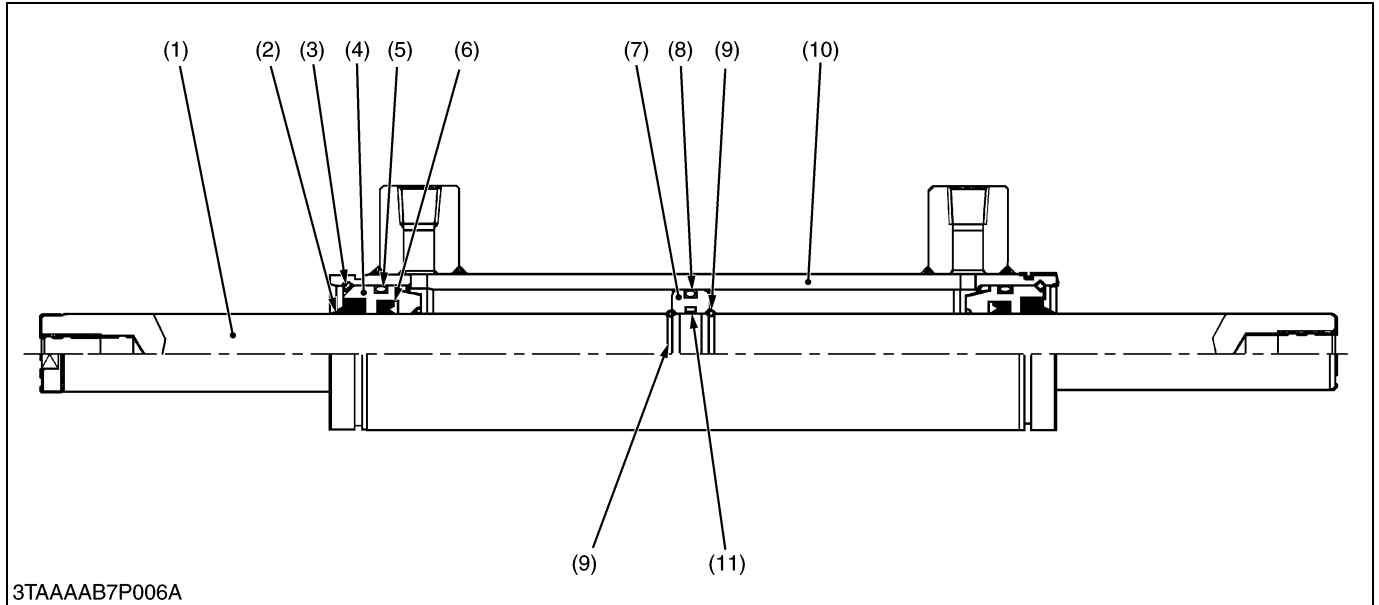

- | | | | |
|------------------------|---------------|------------------------|--------------------|
| (1) Rod | (4) Guide | (7) Center Piston | (10) Cylinder Tube |
| (2) Wiper Seal | (5) O-ring | (8) Piston O-ring | (11) Rod O-ring |
| (3) Internal Snap Ring | (6) Seal Ring | (9) External Snap Ring | |

The steering cylinder is single piston both rod double-acting type. This steering cylinder is installed parallel to the front axle and connected to tie-rods.

The tie-rods connected to both knuckle arm guarantees equal steering movement to both front wheels.

The steering cylinder provide force in both directions. Depending upon direction the steering wheel is turned pressure oil enters at one end of the cylinder to extend, or the other end to retract it, thereby turning front wheel of the tractor.

SERVICING

CONTENTS

1. TROUBLESHOOTING	4-S1
2. SERVICING SPECIFICATIONS	4-S2
3. TIGHTENING TORQUES	4-S3
4. CHECKING, DISASSEMBLING AND SERVICING.....	4-S4
[1] CHECKING	4-S4
(1) Relief Valve.....	4-S4
[2] PREPARATION	4-S4
(1) Separating Power Steering Controller	4-S4
(2) Separating Power Steering Cylinder.....	4-S6
[3] DISASSEMBLING AND ASSEMBLING.....	4-S8
(1) Power Steering Cylinder	4-S8
[4] SERVICING	4-S9

1. TROUBLESHOOTING

Symptom	Probable Cause	Solution	Reference Page
Cannot Be Steered	Steering controller malfunctioning	Replace	4-S5
Hard Steering	Power steering oil improper	Change with specified oil	G-7
	Hydraulic pump malfunctioning	Replace	5-S13
	Flow priority valve malfunctioning	Repair or replace	5-M6
	Steering controller malfunctioning	Replace	4-S5
Steering Force Fluctuates	Steering controller malfunctioning	Replace	4-S5
	Flow priority valve malfunctioning	Replace	5-M6
	Air sucked in pump due to lack of oil	Replenish	G-7
	Air sucked in pump from suction circuit	Repair	5-S13
Steering Wheel Turns Spontaneously When Released	Steering controller malfunctioning	Replace	4-S5
Front Wheels Wander to Right and Left	Steering controller malfunctioning	Replace	4-S5
	Air sucked in pump due to lack of oil	Replenish	G-7
	Air sucked in pump from suction circuit	Repair	5-S13
	Insufficient bleeding	Bleed	G-30
	Cylinder malfunctioning	Repair or replace	4-S8
	Improper toe-in adjustment	Adjust	3-S4
	Tire pressure uneven	Inflate	G-41
Wheels Are Turned to a Direction Opposite to Steering Direction	Cylinder piping connected in reverse	Repair	4-S6, S7
Steering Wheel Turns Idle in Manual Steering	Insufficient bleeding	Bleed	G-30
	Air sucked in due to lack of oil	Replenish	G-7
Noise	Air sucked in pump due to lack of oil	Replenish	G-7
	Air sucked in pump from suction circuit	Repair	5-S13
	Pipe deformed	Replace	–
Oil Temperature Increases Rapidly	Steering controller (relief valve) malfunctioning	Replace	4-S5

W1014322

2. SERVICING SPECIFICATIONS

POWER STEERING BODY

Item		Factory Specification	Allowable Limit
Relief Valve	Operating Pressure	8.34 to 8.82 MPa 85.0 to 90.0 kgf/cm ² 1210 to 1280 psi	–

W1013874

STEERING CYLINDER

Steering Cylinder	I.D.	40.000 to 40.062 mm 1.5748 to 1.5772 in.	40.100 mm 1.5787 in.
Piston Rod to Guide	Clearance	0.020 to 0.070 mm 0.00079 to 0.0027 in.	0.200 mm 0.00787 in.

W1013973

3. TIGHTENING TORQUES

Tightening torques of screws, bolts and nuts on the table below are especially specified.
(For general use screws, bolts and nuts : See page G-9.)

Item	N·m	kgf·m	lbf·ft
Steering wheel mounting nut	20 to 25	2.0 to 2.6	15 to 18
Power steering hose	24 to 27	2.4 to 2.8	18 to 20
Power steering cylinder mounting screw	48 to 55	4.9 to 5.7	36 to 41
Tie-rod slotted nut	18 to 34	1.8 to 3.5	13 to 25
Tie-rod screw	74 to 84	7.5 to 8.6	55 to 62

W1012736



Steering Wheel

1. Remove the steering wheel cap (1).
2. Remove the steering wheel mounting nut and remove the steering wheel.

(When reassembling)

Tightening torque	Steering wheel mounting nut	20 to 25 N·m 2.0 to 2.6 kgf·m 15 to 18 lbf·ft
-------------------	-----------------------------	---

(1) Steering Wheel Cap

W1011793

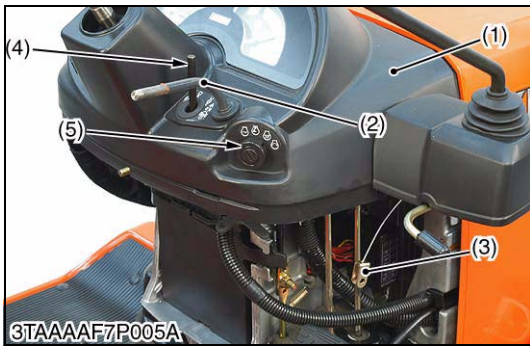

Meter Panel

1. Disconnect the main switch connector and combination switch connector (7).
2. Remove the hand accelerator lever grip and cruise control lever knob.
3. Disconnect the hand accelerator wire (3) and then turn the hand accelerator lever (2) to the operator seat side.
4. Open the bonnet, remove the panel mounting screws and dismount the meter panel.

- | | |
|----------------------------|--------------------------------------|
| (1) Meter Panel | (5) Main Switch |
| (2) Hand Accelerator Lever | (6) Combination Switch |
| (3) hand Accelerator Wire | (7) Connector for Combination Switch |
| (4) Cruise Control Lever | |

W1011901

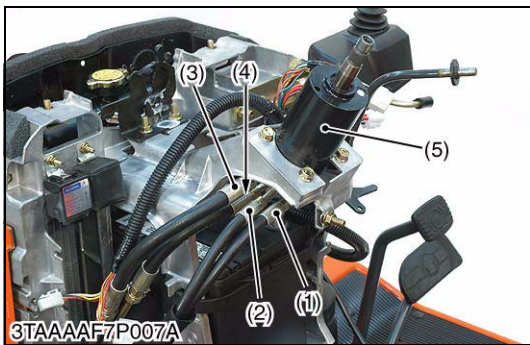

Steering Controller

1. Disconnect the power steering hoses (1), (2), (3), (4).
2. Remove the steering controller mounting screws and remove the steering controller (5).

(When reassembling)

- Be sure to connect the power steering hoses to their original position, and tighten them to the specified torque.

Tightening torque	Power steering hose	24 to 27 N·m 2.4 to 2.8 kgf·m 18 to 20 lbf·ft
-------------------	---------------------	---

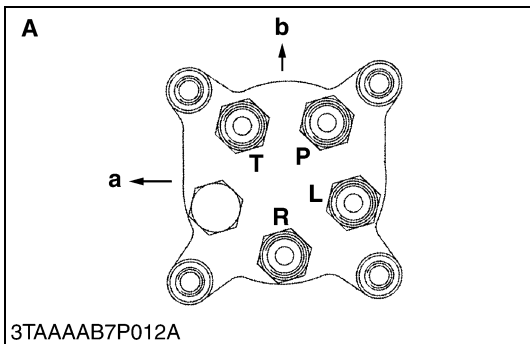

- | | |
|-------------------------|--------------------------------------|
| (1) Cylinder Hose RH | A : Bottom View |
| (2) Cylinder Hose LH | P : Pump Port |
| (3) Delivery Hose | (Connect to Delivery Hose) |
| (4) Return Hose | T : Tank Port |
| (5) Steering Controller | (Connect to Return Hose) |
| | L : L Port |
| | (Connect to Cylinder LH Hose) |
| | R : R Port |
| | (Connect to Cylinder RH Hose) |
| | a : Right |
| | b : Front |

W1012133

(2) Separating Power Steering Cylinder



Bonnet and Under Cover

1. Open the bonnet (1), and then loosen the knob bolts and pull forward to remove the under cover (2).
2. Disconnect the connectors (3) for head light and remove the bonnet bracket (4) with bonnet.

- (1) Bonnet
- (2) Under Cover
- (3) Connector
- (4) Bonnet Bracket

W1017472

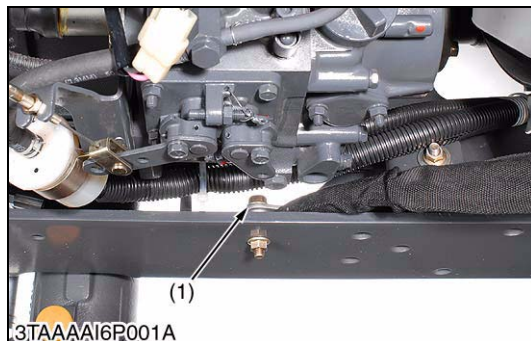

Front Axle Assembly

1. Remove the power steering hose clamp (1).
2. Place the garage jack under the front axle.
3. Remove the cotter pin (1).
4. Remove the slotted nut (2) of center pin and separate the front axle from the frame.
5. Disconnect the power steering cylinder hoses (4).

(When reassembling)

- After mounting the front axle assembly to the frame, be sure to adjust the front axle rocking force. (See page 3-S4.)
- Installing the cotter pin and be sure to split the cotter pin like an anchor

Tightening torque	Power steering cylinder hose	24 to 27 N·m 2.4 to 2.8 kgf·m 18 to 20 lbf·ft
-------------------	------------------------------	---

- (1) Hose Clamp
- (2) Cotter Pin
- (3) Slotted Nut (Adjusting Nut for Front Axle Rocking Force)
- (4) Power Steering Hose

W1016448

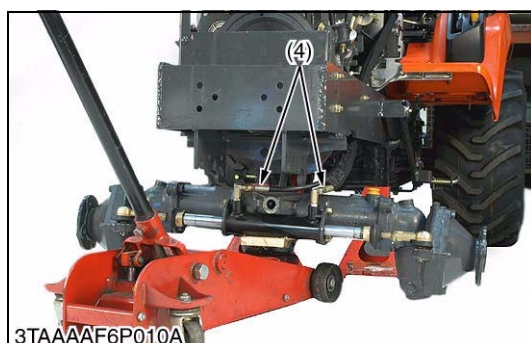
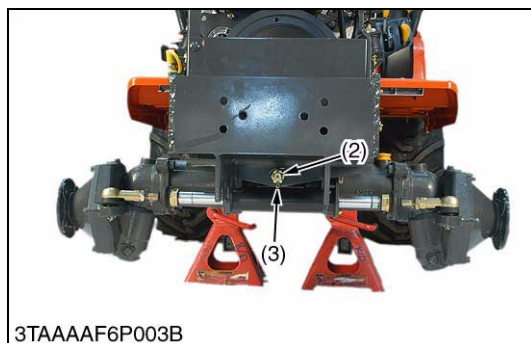

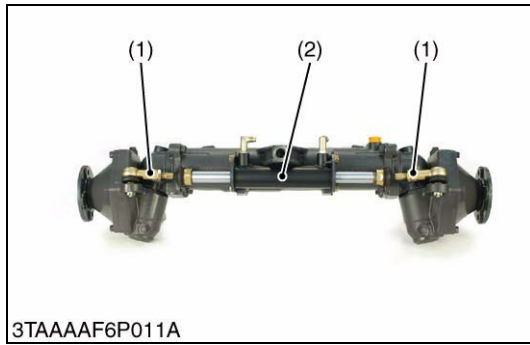

Power Steering Cylinder

1. Remove the cotter pin and remove the slotted nut for tie-rod (1).
2. Remove the power steering cylinder mounting screws and remove the power steering cylinder (2) with tie-rod.

(When reassembling)

■ **NOTE**

- **Tighten the slotted nut to 18 N·m (1.8 kgf·m, 13 lbf·ft). If the slot and pin hole do not meet, tighten the nut until they do meet, and install the cotter pin.**
- **Be sure to split the cotter pin like an anchor.**

Tightening torque	Tie-rod slotted nut	18 to 34 N·m 1.8 to 3.5 kgf·m 13 to 25 lbf·ft
	Power steering cylinder mounting screw	48 to 55 N·m 4.9 to 5.7 kgf·m 36 to 41 lbf·ft

(1) Tie-rod

(2) Power Steering Cylinder

W1016645

[3] DISASSEMBLING AND ASSEMBLING

(1) Power Steering Cylinder

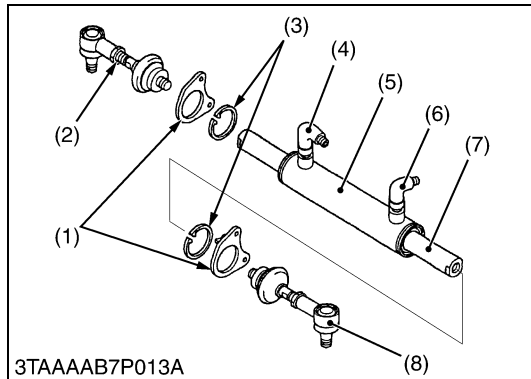

Adaptor and Tie-rod

1. Remove the cylinder hose adaptors (4), (6).
2. Remove the tie-rods (2), (8) from piston rod (7).
3. Remove the cylinder holder (1) and internal snap ring (3).

(When reassembling)

- Be sure to install the hose adaptors (4), (6) as shown figure left.
- After reassembling the tie-rod, be sure to adjust the toe-in. (Refer to 3-S4.)

Tightening torque	Tie-rod screw	74 to 84 N·m 7.5 to 8.6 kgf·m 55 to 62 lbf·ft
-------------------	---------------	---

- | | |
|------------------------|---------------------------|
| (1) Cylinder Holder | (7) Piston Rod |
| (2) Tie-rod RH | (8) Tie-rod LH |
| (3) Internal Snap Ring | |
| (4) Hose Adaptor RH | A : 0.26 rad (15°) |
| (5) Cylinder | B : Front |
| (6) Hose Adaptor LH | |

W1012941

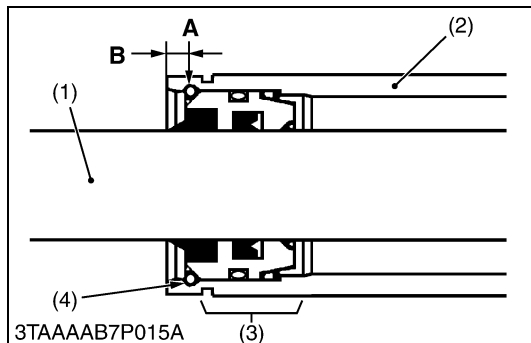
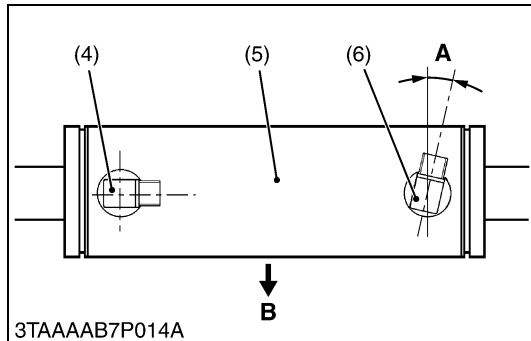

Steering Cylinder

1. Carefully clamp the cylinder in a vise.
2. Push one of the guide assembly (3) to inside of cylinder tube (2).
3. Drill a hole (2.5 mm dia., 0.098 in. dia.) on the cylinder tube (2) just over the snap ring (4) as shown figure left.
4. Take a little screwdriver and lift off the snap ring (4) from its groove. Simultaneous support this action by pushing from the outside of the cylinder tube with another little screwdriver or another tool.
5. Push out the piston rod assembly (9) and take off the guide assembly (3).

(When reassembling)

■ NOTE

- **Seals must be exchanged after disassembling.**
- **Apply transmission fluid to the exchanged seals.**
- **Enter the piston rod and block the guide assemblies with the snap rings.**

- | | |
|--------------------|--------------------------------|
| (1) Piston Rod | (8) O-ring |
| (2) Cylinder Tube | (9) Piston Rod Assembly |
| (3) Guide Assembly | (10) Center Piston |
| (4) Snap Ring | |
| (5) Guide | A : Drill a Hole |
| (6) Seal Ring | B : 5.25 mm (0.207 in.) |
| (7) Wiper Ring | |

W1013441

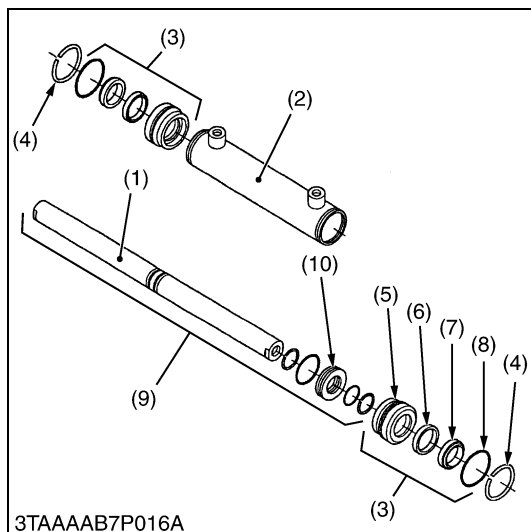

[4] SERVICING

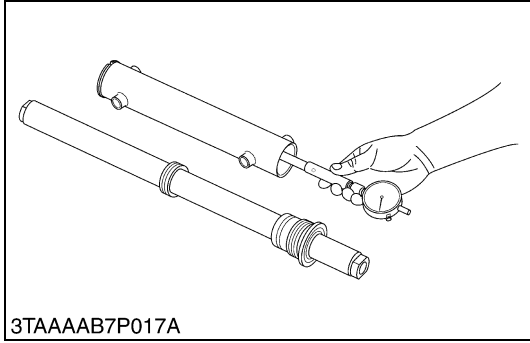

Steering Cylinder I.D.

1. Measure the steering cylinder I.D. with a cylinder gauge.
2. If the cylinder I.D. exceed the allowable limit, replace the cylinder barrel.

Steering cylinder I.D.	Factory spec.	40.000 to 40.062 mm 1.5748 to 1.5772 in.
	Allowable limit	40.100 mm 1.5787 in.

W1013872

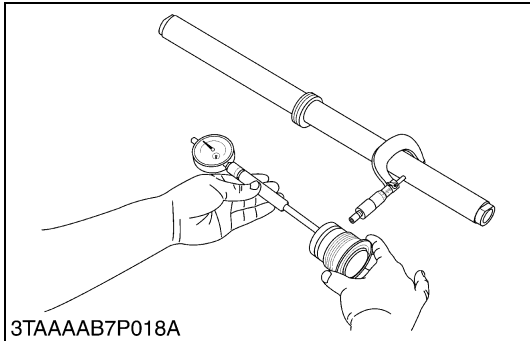

Clearance between Rod and Guide

1. Measure the rod guide I.D. with a cylinder gauge.
2. Measure the rod O.D. with an outside micrometer, and calculate the clearance.
3. If the clearance exceeds the allowable limit, replace as a unit.

Clearance between rod and guide	Factory spec.	0.020 to 0.070 mm 0.00079 to 0.0027 in.
	Allowable limit	0.200 mm 0.00787 in.

W1013777

5 HYDRAULIC SYSTEM

MECHANISM

CONTENTS

1. HYDRAULIC CIRCUIT	5-M1
2. HYDRAULIC PUMP	5-M2
3. CONTROL VALVE	5-M3
4. FLOW PRIORITY VALVE	5-M6
5. RELIEF VALVE	5-M7
6. HYDRAULIC CYLINDER	5-M9
7. HYDRAULIC BLOCK TYPE OUTLET	5-M10
8. MOWER LINKAGE	5-M11

1. HYDRAULIC CIRCUIT

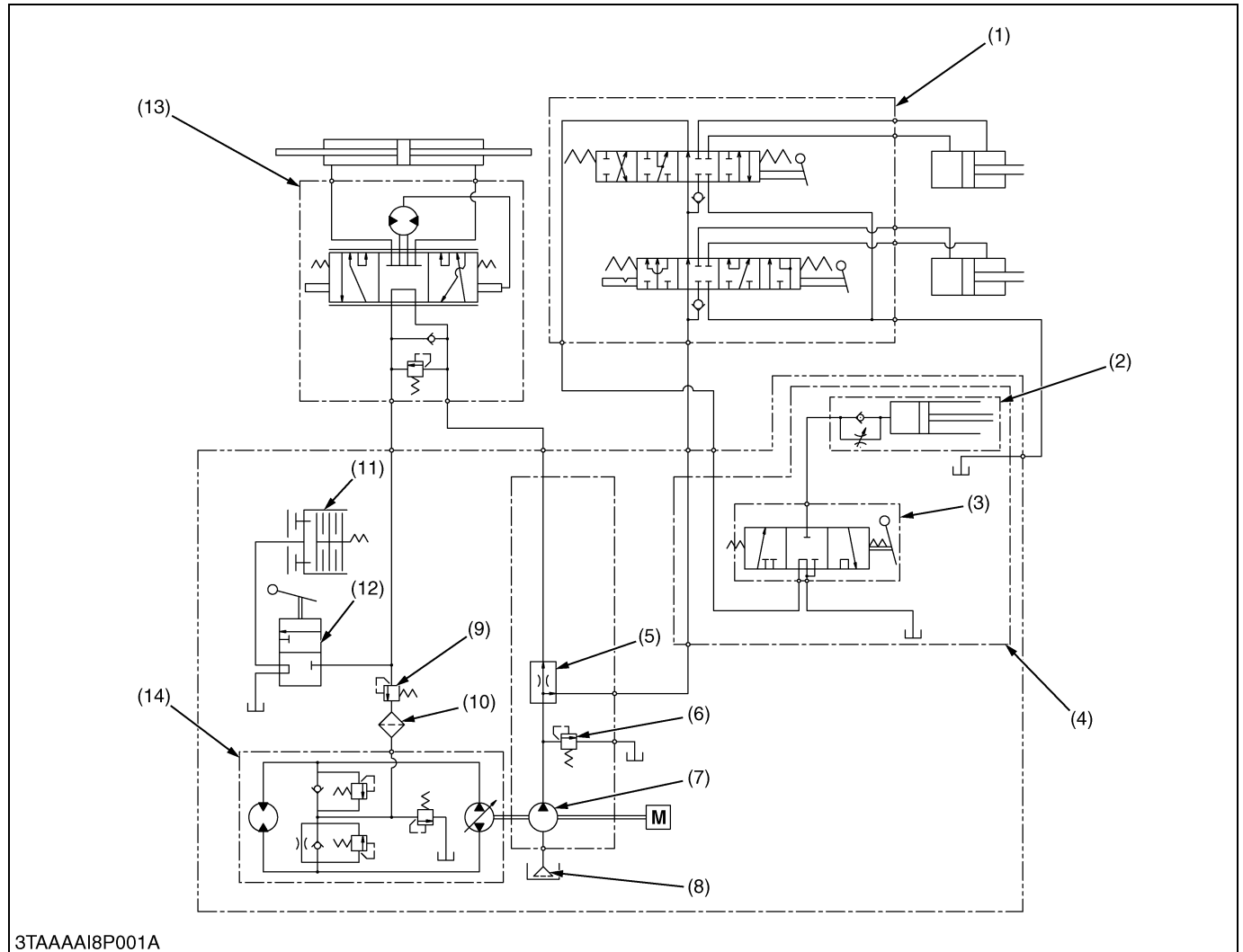

- | | | | |
|--|--------------------------|-----------------------------|--------------------------------|
| (1) Auxiliary Hydraulic Control Valve Assembly (If equipped) | (4) 3 Point Hitch System | (8) Oil Strainer | (12) PTO Clutch Valve |
| (2) Hydraulic Cylinder | (5) Flow Priority Valve | (9) PTO Clutch Relief Valve | (13) Power Steering Controller |
| (3) Control Valve | (6) Relief Valve | (10) Oil Filter | (14) Hydrostatic Transmission |
| | (7) Hydraulic Pump | (11) PTO Clutch | |

The hydraulic system of this tractor is composed of a hydraulic pump, control valve for front loader, 3 point hitch system and other components.

This system has the following functions :

1. Oil is supplied by hydraulic pump which is driven by pump drive shaft in the transmission case. As the pump drive shaft is connected to the propeller shaft, hydraulic pump starts running when engine is started.
2. The hydraulic pump supplies the high pressured oil to auxiliary hydraulic control valve for front loader, control valve for 3 point hitch system, power steering controller, PTO clutch valve and hydrostatic transmission after dividing oil flow by flow priority valve.

2. HYDRAULIC PUMP

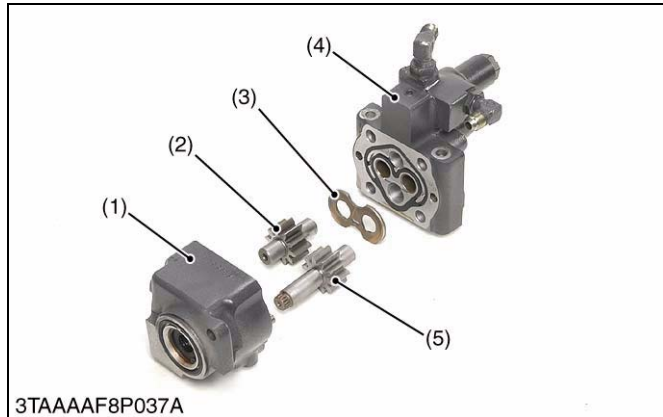

The hydraulic pump is composed of the casing (1), cover (4), side plate (3), and two spur gears (drive gear (5) and driven gear (2)) that are in mesh.

Hydraulic pump is driven by the pump drive shaft in the transmission case.

Maximum displacement is as follows.

Displacement	Engine speed	Condition
23.5 L/min. 6.2 U.S.gals./min. 5.2 Imp.gals./min.	At 3200 min ⁻¹ (rpm)	at no load

- (1) Casing
- (2) Driven Gear
- (3) Side Plate
- (4) Cover
- (5) Drive Gear
- (6) Pin
- (7) Oil Seal

W1013860

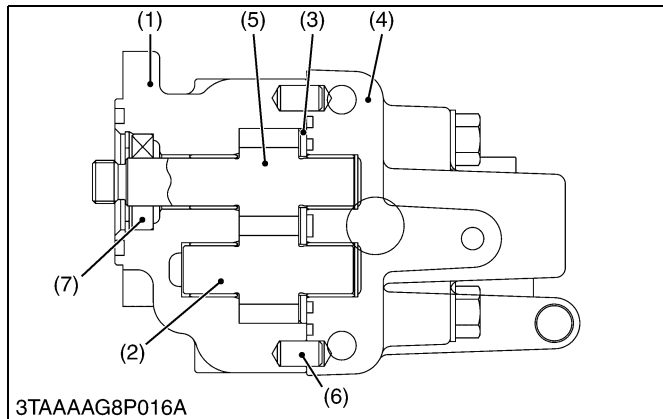

3. CONTROL VALVE

This position control valve is located under the hydraulic cylinder.

This control valve is mechanically connected to the position control lever.

Since the feedback rod is not equipped to the lift arm, the neutral position adjustment is adjusted by controlling the position control lever.

The control valve controls the oil flow forced from the hydraulic pump and the oil returned back from the hydraulic cylinder.

■ **Neutral**

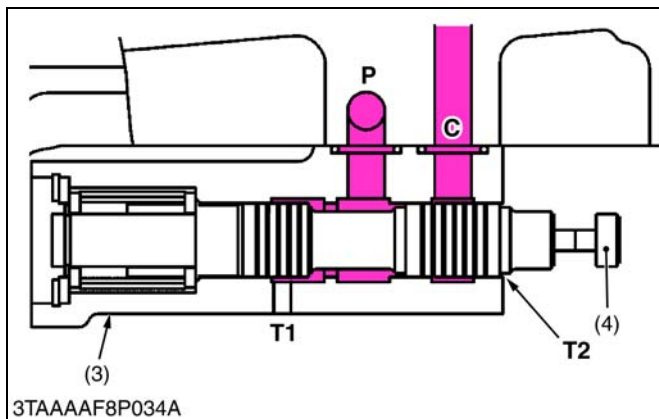
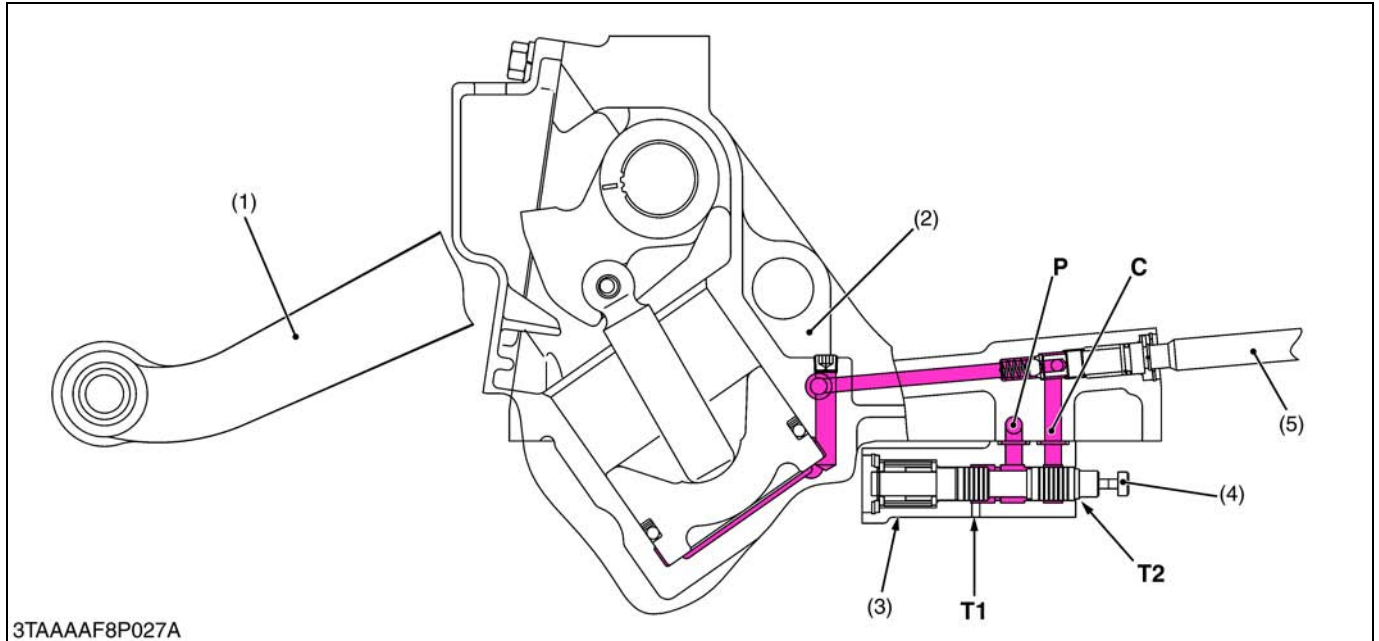

When stopping the position control lever, the spool is stopped.

The spool closes the oil flow from passage between **P** port and **C** port.

Since the oil in the hydraulic cylinder is not drained to **T2** port, “Neutral” position is kept.

- | | |
|------------------------------|--------------------------|
| (1) Lift Arm | P : Pump Port |
| (2) Hydraulic Cylinder | C : Cylinder Port |
| (3) Control Valve | T1 : Tank Port |
| (4) Spool | T2 : Tank Port |
| (5) Lowering Adjusting Shaft | |

W1015913

■ Lift

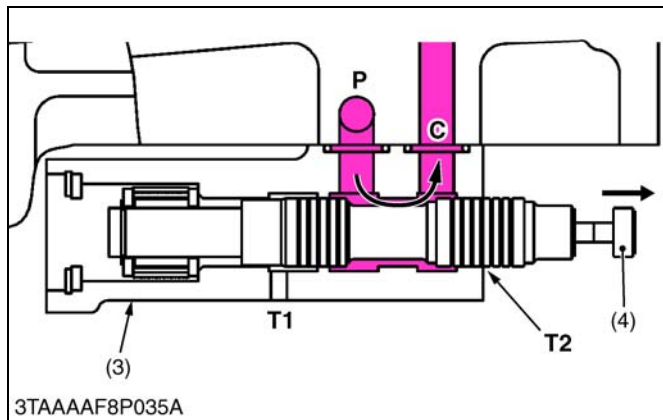
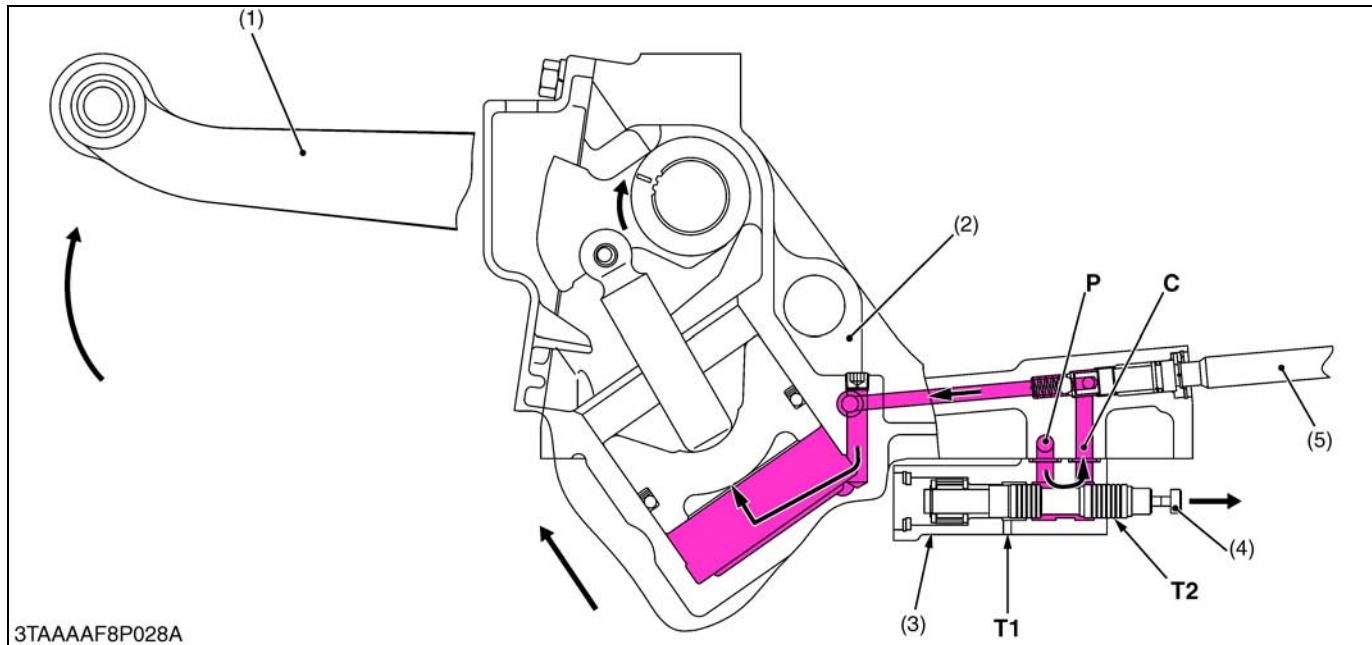

When the control lever is set to the “Lift” position, the spool (4) moves to the right.

The oil forced into the control valve flows through P port to C port and the hydraulic cylinder.

The oil pushes the hydraulic piston in the hydraulic cylinder to lift the implement.

Since the spool shape is step down structure, oil passes slowly through the gap between the control valve body (3) and the spool (4) to C port.

In this tractor, when setting the control lever to the “Slow up”, implement lifts up with ease in increments of approximately 1/4 inches at lower link end.

- | | |
|------------------------------|--------------------------|
| (1) Lift Arm | P : Pump Port |
| (2) Hydraulic Cylinder | C : Cylinder Port |
| (3) Control Valve | T1 : Tank Port |
| (4) Spool | T2 : Tank Port |
| (5) Lowering Adjusting Shaft | |

W1016112

■ Down

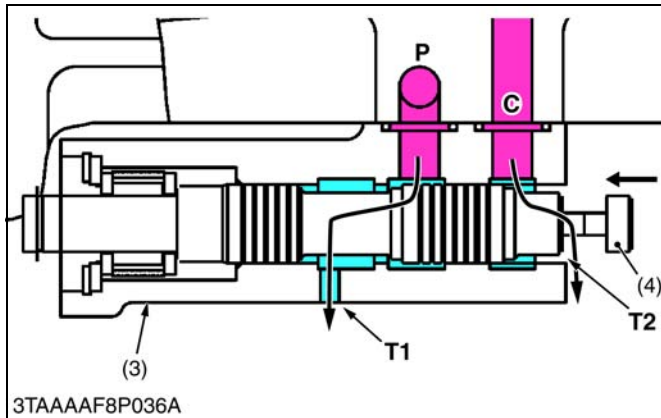
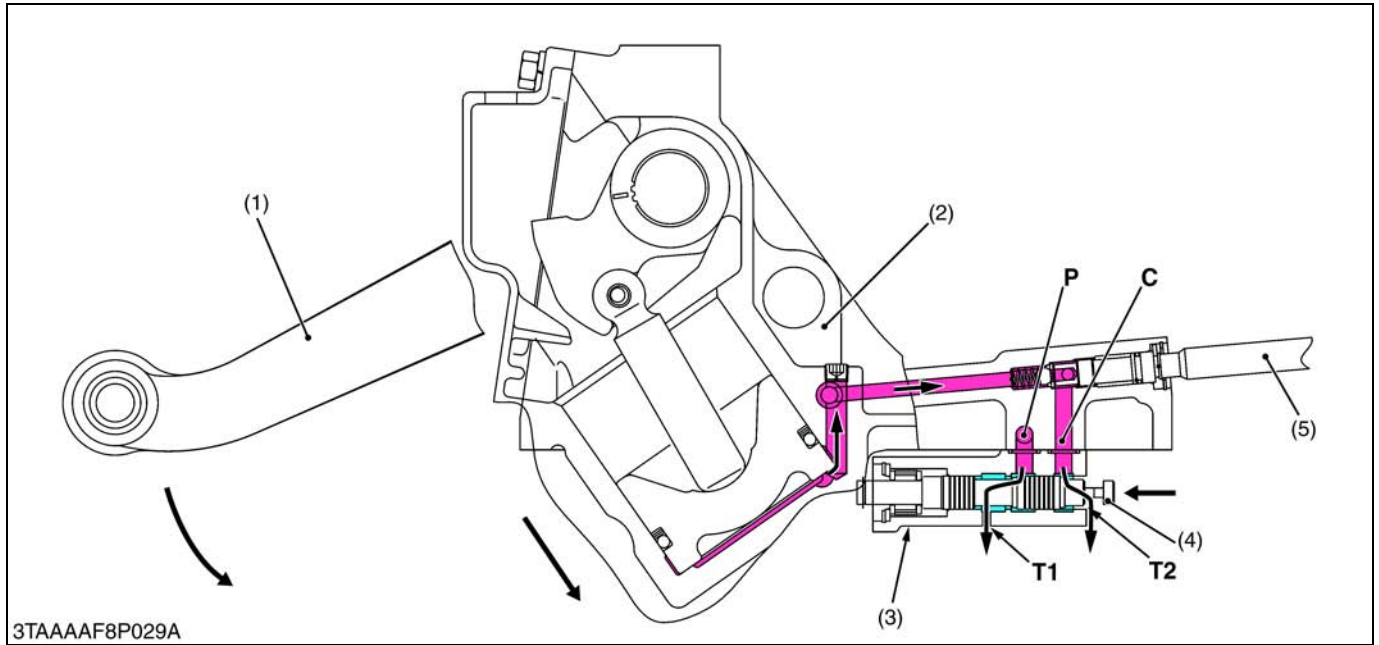

When the control lever is set to the “Down” position, the spool (4) moves to the left.

The oil forced from the **P** port flows through the gap between the control valve body and the spool to the **T1** port.

The oil in the hydraulic cylinder flows through the gap between the control valve body (3) and the spool (4) to the **T2** port.

Since the oil in the hydraulic cylinder drains to the transmission case, the implement lowers.

Since the spool shape is step down structure, oil pass slowly from **C** port through the gap between the control valve body (3) and the spool (4) to **T2** port.

In this tractor, when setting the control lever to the “Slow down” position, implement lowers down with ease in increments of approximately 1/4 inches at lower link end.

- | | |
|------------------------------|--------------------------|
| (1) Lift Arm | P : Pump Port |
| (2) Hydraulic Cylinder | C : Cylinder Port |
| (3) Control Valve | T1 :Tank Port |
| (4) Spool | T2 :Tank Port |
| (5) Lowering Adjusting Shaft | |

W1016319

4. FLOW PRIORITY VALVE

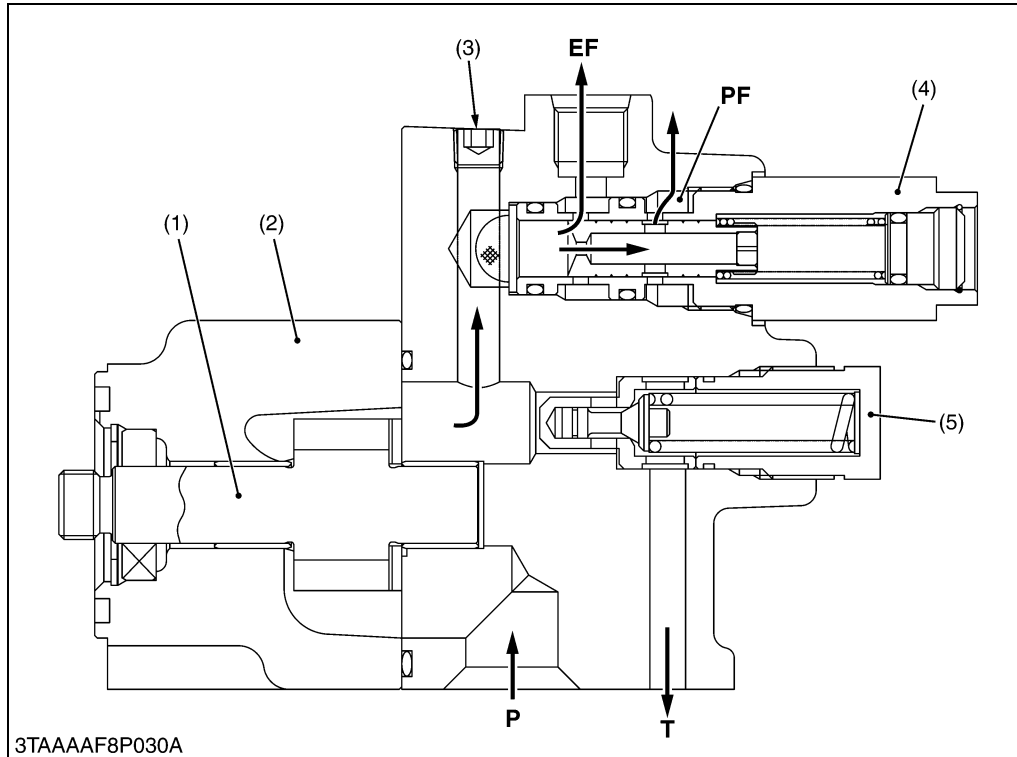

- (1) Hydraulic Pump Gear
- (2) Hydraulic Pump Case
- (3) Plug
- (4) Flow Priority Valve
- (5) Relief Valve

EF :EF Port (To 3 Points Hitch Control Circuit)

PF :PF Port (To Power Steering, PTO Clutch and HST Circuit)

P : Pump Port (Suction)

T : Tank Port

W1014933

The flow priority valve is a flow divider that divides single hydraulic source (hydraulic pump) to actuates two circuits simultaneously.

This valve feeds fixedly controlled flow (8.0 L/min., 2.1 U.S.gals./min., 1.8 Imp.gals./min.) to the **PF** port with priority and excessive flow to the **EF** port.

5. RELIEF VALVE

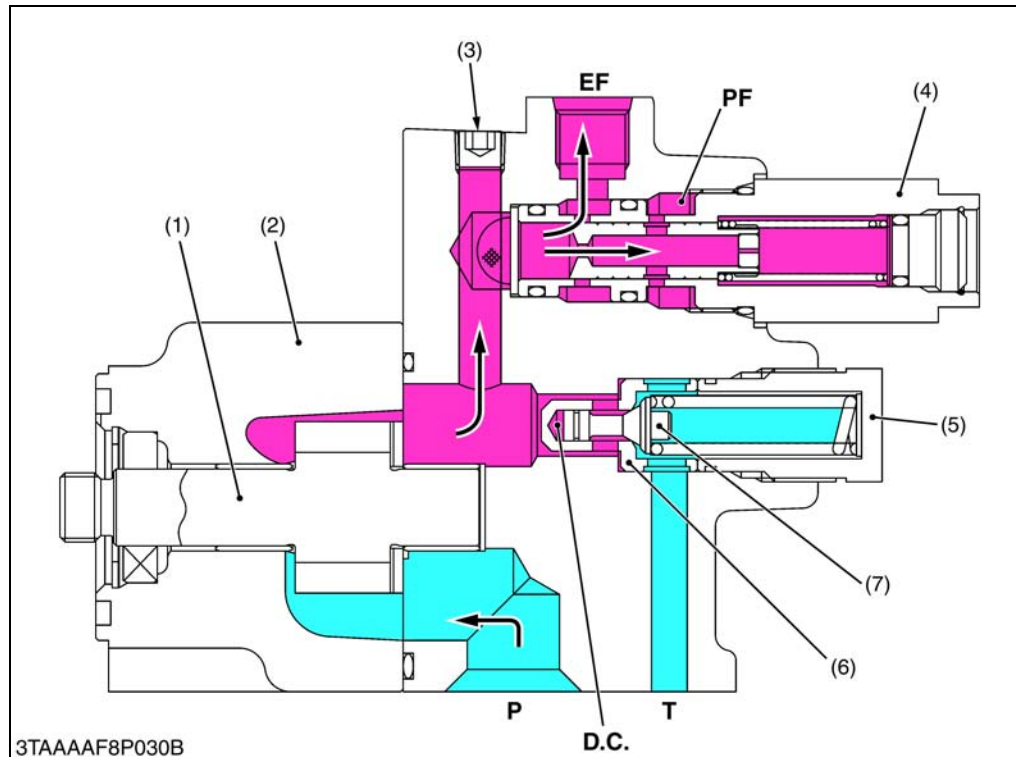

- (1) Hydraulic Pump Gear
- (2) Hydraulic Pump Case
- (3) Plug
- (4) Flow Priority Valve
- (5) Relief Valve
- (6) Seat
- (7) Poppet

EF :EF Port (To 3 Points Hitch Control Circuit)

PF :PF Port (To Power Steering, PTO Clutch and HST Circuit)

D.C.:Damping Chamber

P : Pump Port (Suction)

T : Tank Ports

W1015272

3TAAAF8P030B

The implement control system circuit has a relief valve to restrict the maximum pressure in the circuit. The relief valve is located in the hydraulic control valve assembly.

The relief valve is a guide piston type with damping effect.

Among direct acting relief valves, this type is suited to higher pressure and has large capacity. Furthermore, this type is free from unstable operation, such as chattering, which occurs often in direct acting relief valves.

As shown in the figure, the guide is attached to the poppet (7) and a valve chamber **D.C.** (called the damping chamber) is formed at the top of the guide piston. The inlet of the valve leads to the chamber via a clearance between the sliding portion of the guide and the seat (6), minimizing valve vibration with the damping effect of the chamber.

■ Relief Valve Operating

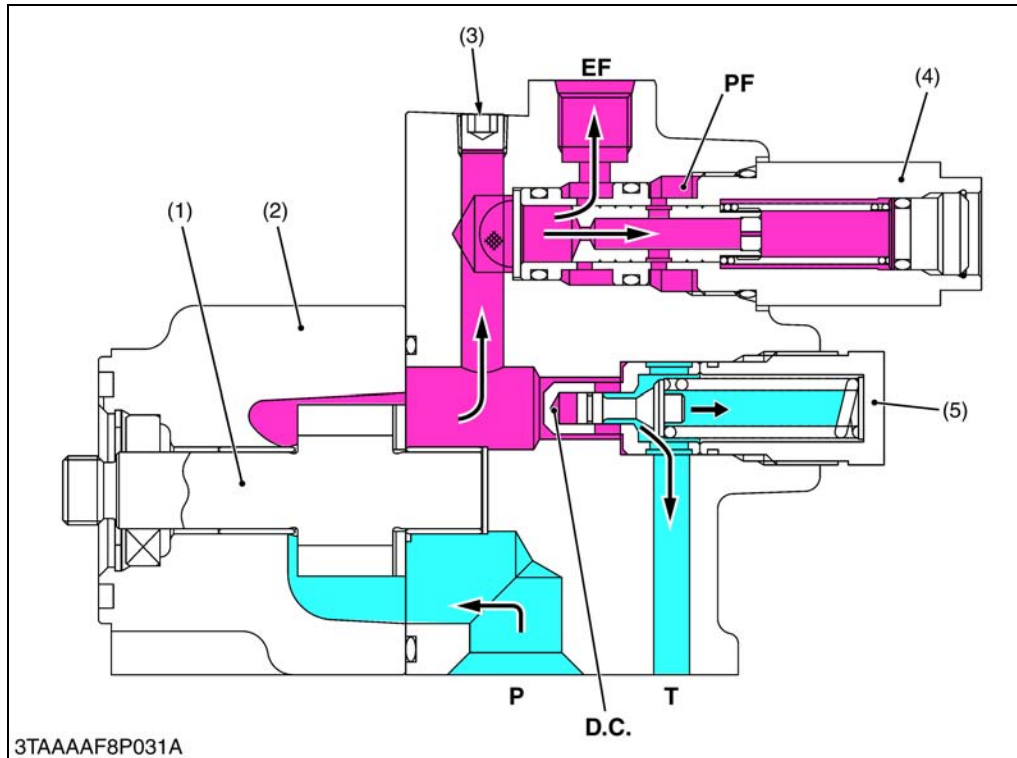

- (1) Hydraulic Pump Gear
- (2) Hydraulic Pump Case
- (3) Plug
- (4) Flow Priority Valve
- (5) Relief Valve

EF :EF Port (To 3 Points Hitch Control Circuit)

PF :PF Port (To Power Steering, PTO Clutch and HST Circuit)

D.C.:Damping Chamber

P : Pump Port (Suction)

T : Tank Ports

W1016573

When the oil pressure in the circuit is lower than the setting pressure of the relief valve, the relief valve is not operated and the oil fed to the relief valve from the hydraulic pump flows into the implement control valve.

As the oil pressure in the circuit increases, so does the pressure in the damping chamber **D.C.**. When the pressure rises above the valve setting and overcomes the spring force, the valve opens. Oil then flows out to the transmission case through **T** port, preventing any further rise in pressure. The valve closes again when enough oil is released to drop pressure below the valve setting.

(Reference)

- Relief valve setting pressure : 12.3 to 12.7 MPa
125 to 130 kgf/cm²
1780 to 1840 psi
- Engine speed : Maximum
- Oil temperature : 40 to 50 °C
104 to 122 °F

6. HYDRAULIC CYLINDER

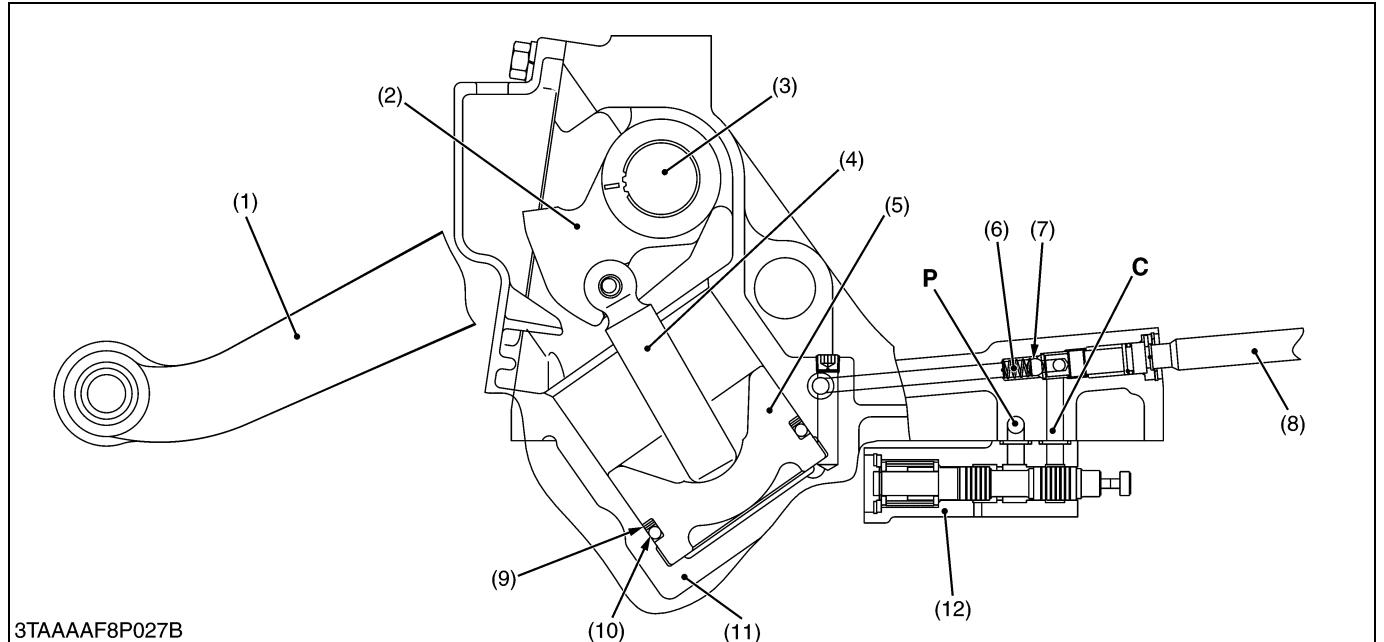

- | | | | |
|-------------------------|------------------------------------|-------------------------|--------------------------|
| (1) Lift Arm | (5) Piston | (9) Back-up Ring | P : Pump Port |
| (2) Hydraulic Arm | (6) Spring | (10) O-ring | C : Cylinder Port |
| (3) Hydraulic Arm Shaft | (7) Ball | (11) Hydraulic Cylinder | |
| (4) Hydraulic Rod | (8) Lowering Speed Adjusting Shaft | (12) Control Valve | |

The main components of the hydraulic cylinder are shown in the figure above.

While the lift arm (1) is rising, oil from the hydraulic pump flows into the hydraulic cylinder through the hydraulic control valve (12) and cylinder port (C). Then oil pushes out the piston (5).

While the lift arm (1) is lowering, oil in the hydraulic cylinder is discharged to the transmission case through the hydraulic control valve by the weight of the implement. At this time, the lowering speed of the implement can be controlled by the ball (7) attached to the hydraulic cylinder (11). Turning the lowering speed adjusting knob clockwise decreases the lowering speed, and counterclockwise increases lowering speed. When the lowering speed adjusting valve is completely closed, the lift arm (1) is held at its position since oil in the hydraulic cylinder is sealed between the piston (5) and ball (7).

7. HYDRAULIC BLOCK TYPE OUTLET

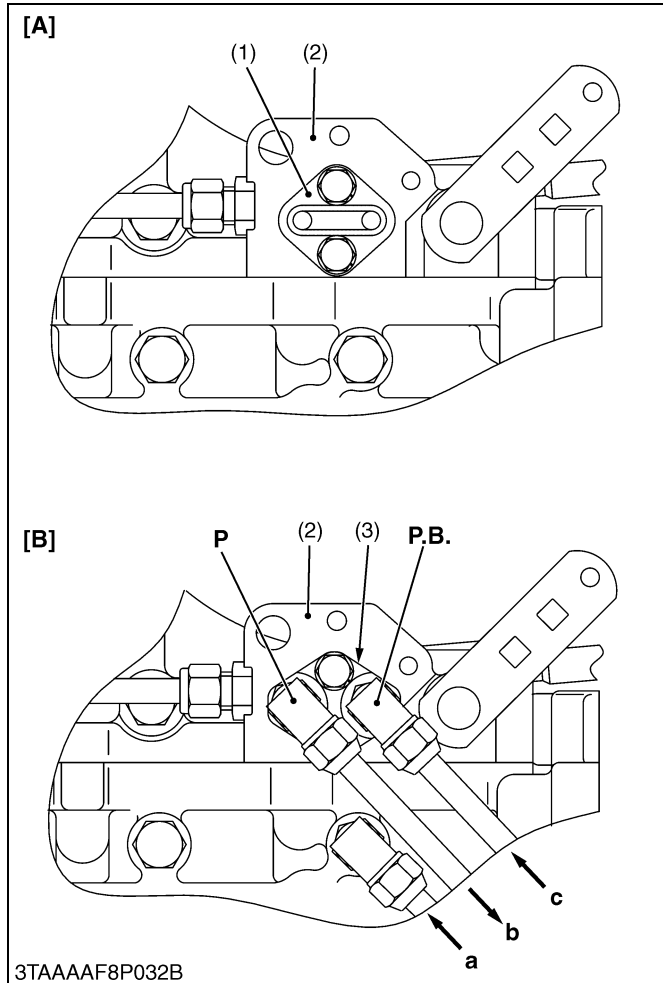

The hydraulic block type outlet is located on the hydraulic cylinder assembly.

This hydraulic block type outlet is provided to take power out from the tractor to operate the hydraulic cylinders on the implement, such as front end loader, front snow blade and so on.

- (1) Block Cover
- (2) Hydraulic Cylinder
- (3) Hydraulic Block

P : P Port (Pump)
P.B. :P.B. Port (Power Beyond)

[A] When Auxiliary Control

Valve is not Attached

[B] When Auxiliary Control

Valve is Attached

a : To Transmission Case

b : To Implement

c : From Implement

W1014064

8. MOWER LINKAGE

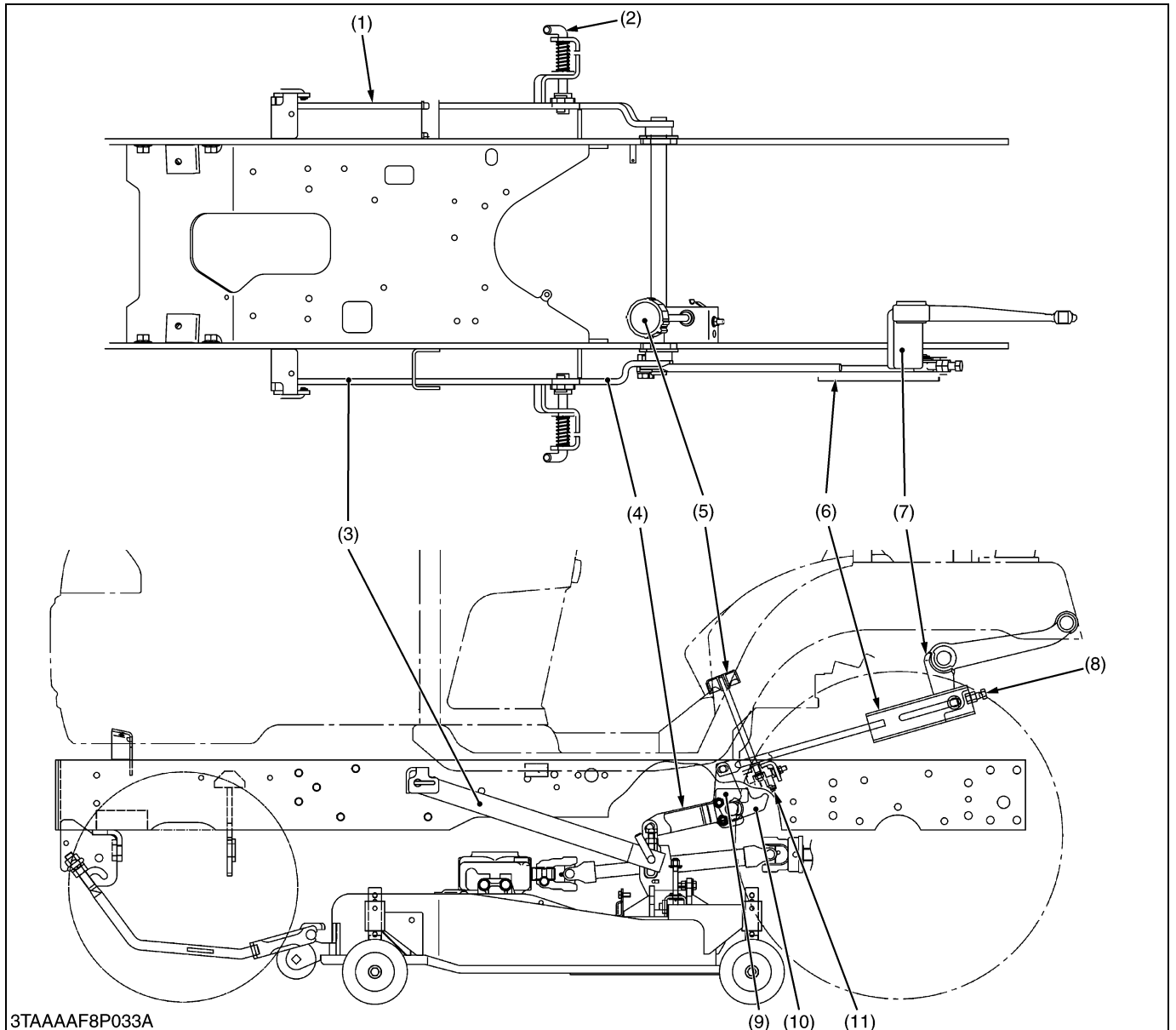

- | | | | |
|------------------------|-----------------------------------|---------------------|----------------------|
| (1) Mower Rear Link RH | (4) Rear Lift Link LH | (7) Lift Arm | (10) Lift Lower Boss |
| (2) Lift Pin | (5) Cutting Height Adjusting Dial | (8) Adjusting Bolt | (11) Cam |
| (3) Mower Rear Link LH | (6) Rear Lift Link LH | (9) Lift Upper Boss | |

The mower rear link (1), (3) and the lift arm (7) are linked with the rear lift link LH (4), the lift upper boss (9) and the lift lower boss (10).

As the hydraulic control lever moves to lift position, lift arm (7) is raised and the rear lift link LH (6) is pulled to pull the lift links to the rearward. As a result, mower rear link (1), (3) are lifted.

The cutting height adjusting dial (5) adjusts cutting height of mower by rotating the adjusting cam (11). The position of mower rear link (1), (3) are adjusted by changing the length of the adjusting bolt (8).

SERVICING

CONTENTS

1. TROUBLESHOOTING	5-S1
2. SERVICING SPECIFICATIONS	5-S2
3. TIGHTENING TORQUES	5-S3
4. CHECKING, DISASSEMBLING AND SERVICING.....	5-S4
[1] CHECKING AND ADJUSTING	5-S4
(1) Relief Valve.....	5-S4
(2) Pump and Priority Valve	5-S5
(3) Mower Lift Linkage.....	5-S6
[2] PREPARATION	5-S7
(1) Separating Hydraulic Cylinder	5-S7
(2) Separating Hydraulic Pump	5-S10
[3] DISASSEMBLING AND ASSEMBLING.....	5-S14
(1) Hydraulic Cylinder and Control Valve	5-S14
(2) Mower Lift Linkage.....	5-S16
[4] SERVICING	5-S17
(1) Hydraulic Pump.....	5-S17
(2) Hydraulic Cylinder.....	5-S18

1. TROUBLESHOOTING

Symptom	Probable Cause	Solution	Reference Page
Implement Does Not Rise (No Noise)	Control valve broken	Replace	5-S14
	Control valve improperly assembled	Repair	5-S14
	Relief valve spring damaged	Replace	5-S4
	Spool sticks	Repair	5-S14
	Piston O-ring or cylinder damaged	Replace	5-S15
Implement Does Not Rise (Noise)	Oil filter cartridge clogged	Replace	G-14
	Suction pipe loosen or broken	Repair or replace	–
	Suction pipe connecting hose loosen or broken	Repair or replace	–
	Suction pipe O-ring broken	Replace	–
	Insufficient transmission oil	Refill	G-24
	Relief valve setting pressure too low	Adjust or replace	5-S4
	Hydraulic pump broken	Replace	5-S13
Implement Does Not Lower	Control valve malfunctioning	Repair or replace	5-S14
Implement Drops by Its Weight	Hydraulic cylinder worn or damaged	Replace	5-S15
	Piston O-ring worn or damaged	Replace	5-S15
	Control valve malfunctioning	Replace	5-S14

W1014322

2. SERVICING SPECIFICATIONS

Item		Factory Specification	Allowable Limit
Relief Valve	Setting Pressure (Condition) Engine speed : Maximum Oil Temperature : 45 to 55 °C 113 to 131 °F	12.3 to 12.7 MPa 125 to 130 kgf/cm ² 1780 to 1840 psi	–
Hydraulic Pump	Power steering oil flow (Condition) Engine speed : 1500 min ⁻¹ (rpm) Oil Temperature : 45 to 55 °C 113 to 131 °F	Above 8.0 L/min. 2.1 U.S.gals/min. 1.8 Imp.gals/min.	–
Mower Linkage	Clearance L2	0 to 0.5 mm 0 to 0.01 in.	–
[Hydraulic Pump] Gear to Casing	Clearance	–	0.15 mm 0.0059 in.
Gear	O.D.	33.520 to 33.530 mm 1.3197 to 1.3200 in.	–
Case	I.D.	33.570 to 33.577 mm 1.3217 to 1.3219	–
Gear Shaft to Bushing	Clearance	0.020 to 0.091 mm 0.00079 to 0.0035 in.	0.12 mm 0.0047 in.
Gear Shaft	O.D.	14.970 to 14.980 mm 0.58937 to 0.58976 in.	–
Bushing	I.D.	15.000 to 15.061 mm 0.59056 to 0.59295 in.	–
Side Plate	Thickness	2.48 to 2.50 mm 0.0977 to 0.0984 in.	2.40 mm 0.094 in.
Hydraulic Cylinder	I.D.	80.05 to 80.15 mm 3.152 to 3.155 in.	80.20 mm 3.157 in.

W1013874

3. TIGHTENING TORQUES

Tightening torques of screws, bolts and nuts on the table below are especially specified.
(For general use screws, bolts and nuts : See page G-9.)

Item	N·m	kgf·m	lbf·ft
ROPS mounting nut	124 to 147	12.6 to 15.0	91.2 to 108
Fuel tank stay mounting bolt and nut	48 to 55	4.9 to 5.7	36 to 41
Fender bracket mounting bolt	124 to 147	12.6 to 15.0	91.2 to 108
Hydraulic cylinder block mounting bolt	40 to 44	4.0 to 4.5	29 to 32
Hydraulic pump mounting bolt (M6)	7.9 to 9.3	0.80 to 0.95	5.8 to 6.8
Hydraulic pump mounting bolt (M8)	18 to 21	1.8 to 2.1	13 to 15

W1012736

4. CHECKING, DISASSEMBLING AND SERVICING

[1] CHECKING AND ADJUSTING

(1) Relief Valve

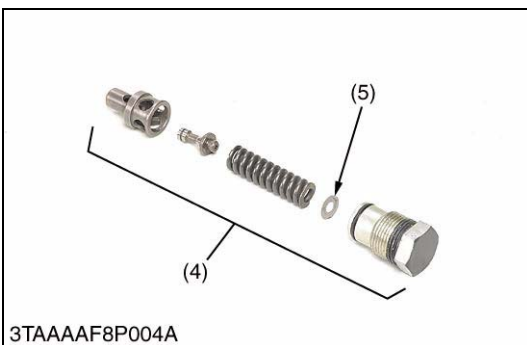
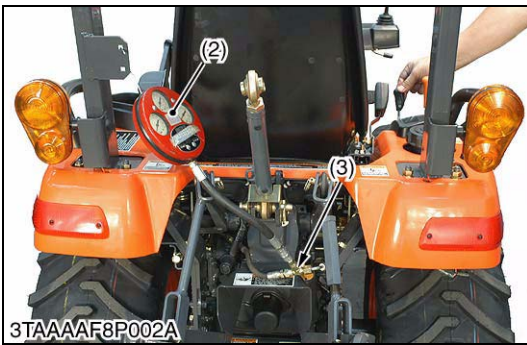

Relief Valve Setting Pressure

1. Remove the hydraulic pipe (1).
2. Install the hose and adaptor A (3) with pressure gauge (2).
3. Start the engine and set at maximum speed.
4. Move the control lever all way up to operate the relief valve and read the gauge.
5. If the pressure is not within the factory specifications, adjust with the adjusting shim (5).

Relief valve setting pressure	Factory spec.	12.3 to 12.7 MPa 125 to 130 kgf/cm ² 1780 to 1840 psi
-------------------------------	---------------	--

Condition

- Engine speed : Maximum
- Oil temperature : 45 to 55 °C
113 to 131 °F

(Reference)

- Thickness of shim (5) :
0.1 mm (0.004 in.), 0.2 mm (0.008 in.), 0.4 mm (0.02 in.)
- 0.269 MPa (2.74 kgf/cm², 39.0 psi) pressure is increased whenever the thickness of adjusting shim is increased by 0.1 mm (0.004 in.).

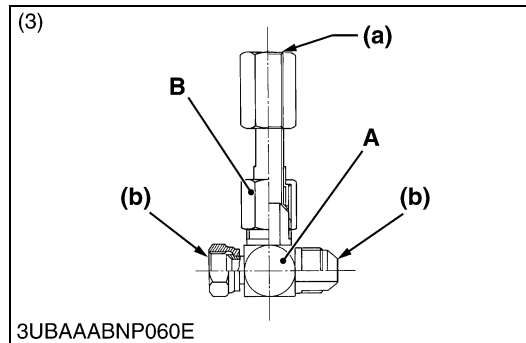

- (1) Hydraulic Pipe
- (2) Pressure Gauge
- (3) Adaptor Tee, Swivel (9/16-18)
- (4) Relief Valve
- (5) Shim

- A : Adaptor Tee, Swivel (9/16-18)**
B : Adaptor B
(a) Connect Pressure Gauge
(b) Connect Hydraulic Hose

W1011231

(2) Pump and Priority Valve



Checking Hydraulic Oil Flow

■ IMPORTANT

- Use the instruction with the flowmeter when you use the flowmeter.
- While testing, do not close the flowmeter loading valve completely.

■ NOTE

- To measure the flow volume of pump, oil flow on the power steering system side should be stopped.

1. Remove the pump hose.
2. Remove the hydraulic pipe behind the hydraulic cylinder and fix the flow meter hose and the flow meter as shown in the photo.

■ Measure the flow volume of power steering.

1. Make sure that the flow volume of pump is 10 L (2.6 U.S.gals, 2.2 Imp.gals) or higher and verify the content below.
If the flow volume is insufficient, measure it after replacing the pump as its priority-valve is unreadable of its condition.
2. After measuring the flow volume, remove the flow meter then reassembling the hydraulic pipe to the original position.
3. Remove the transmission fluid filling plug, then fix the flow meter hose and the flowmeter.
4. Check that a flow volume meets the specifications when the engine revolution is 1500 min⁻¹ (rpm).
5. If the flow volume varies from the specification, replace the priority valve then take measurement again.

Condition

- Engine speed : 1500 min⁻¹ (rpm)
- Oil temperature : 45 to 55 °C
113 to 131 °F

Power steering oil flow	Factory spec.	Above 8.0 L/min. 2.1 U.S.gals/min. 1.8 Imp.gals/min.
-------------------------	---------------	--

(Reference)

- Pump Oil Flow

Hydraulic pump delivery at no pressure	Factory spec.	Above 24.9 L/min. 6.6 U.S.gals/min. 5.5 Imp.gals/min.
--	---------------	---

Condition

- Engine speed : Maximum
- Oil temperature : 45 to 55 °C
113 to 131 °F

(1) Pump Hose

(A) Pump Oil Flow

(B) Power Steering Oil Flow

W12345678

(3) Mower Lift Linkage

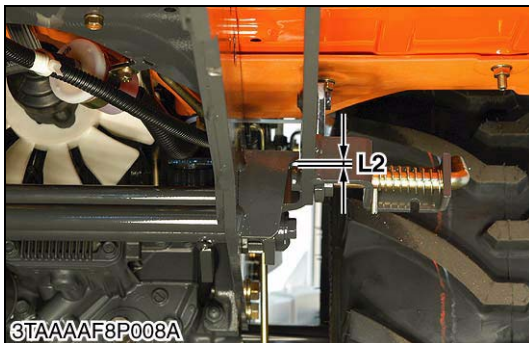
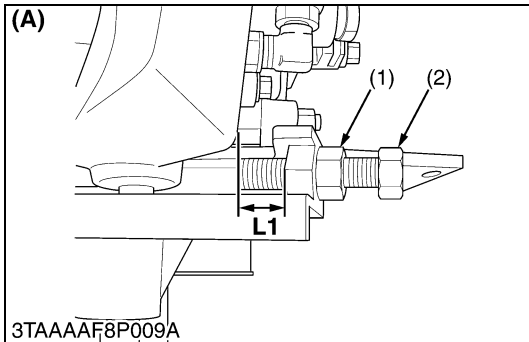
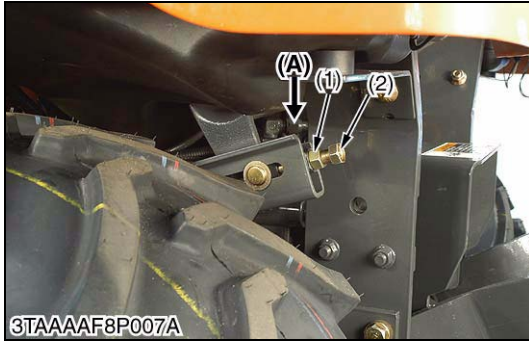

Mower Lift Linkage

After reassembling the mower lift linkage, be sure to adjust it as follows.

1. Check the lift arm free play.
2. Loosen the adjusting nut (1) and start the engine.
3. Move the hydraulic control lever to **Lift** position until the relief valve operating. (**Uppermost** position)
4. Adjusting bolt (2) until the clearance between stopper and mower rear link **LH** gets 0 to 0.5 mm (0 to 0.01 in.)
5. Secure the lock nut (1).

Clearance L2	Factory spec.	0 to 0.5 mm 0 to 0.01 in.
---------------------	---------------	------------------------------

(Reference)

Length L1	Factory spec.	17 mm 0.67 in.
------------------	---------------	-------------------

- (1) Nut
- (2) Bolt

(A) Upper View
L1 : Length
L2 : Clearance

W1020338

[2] PREPARATION

(1) Separating Hydraulic Cylinder

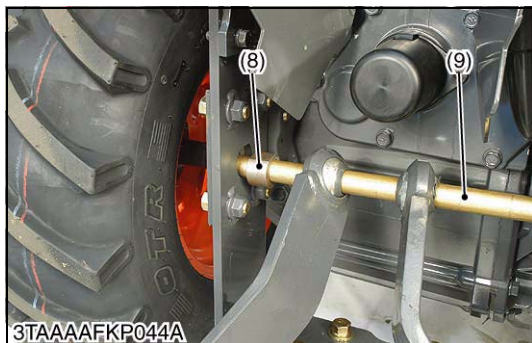
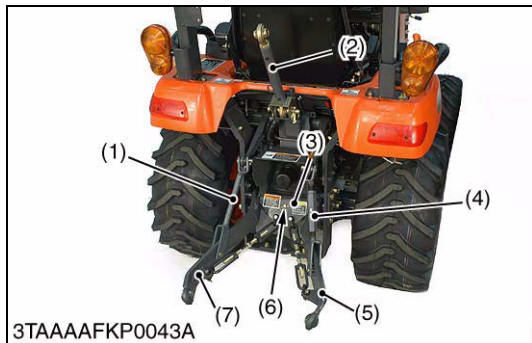
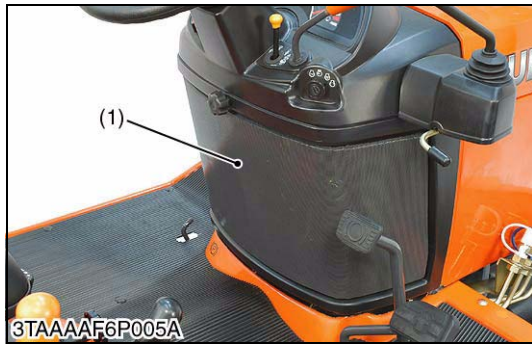

Battery

CAUTION

- When disconnecting the battery cables, disconnect the negative cable from the battery first. When connecting, connect the positive cable to the battery first.

1. Remove the under panel (1).
2. Disconnect the negative cable (2) from the battery.

- | | |
|-----------------|--------------------|
| (1) Under Panel | (3) Negative Cable |
| (2) Battery | |

W1026961

Lift Rod and Lower Link

1. Remove the top link (2).
2. Remove the stopper pin (6) and remove the check chain plate (3).
3. Move the bushes (8) to inside.
4. Move the shaft (9) to right side and remove the lower link as a unit.

- | | |
|-----------------------|-------------------|
| (1) Lift Rod LH | (6) Stopper Pin |
| (2) Top Link | (7) Lower Link LH |
| (3) Check Chain Plate | (8) Bush |
| (4) Lift Rod RH | (9) Shaft |
| (5) Lower Link RH | |

W1036139



Roll-Over Protective Structures (ROPS)

1. Disconnect the lead wires from the hazard lights (2), (4) and turn signal lights (3), (5).
2. Remove the ROPS mounting nuts, and remove the ROPS (1).

(When reassembling)

Tightening torque	ROPS mounting nut	124 to 147 N·m 12.6 to 15.0 kgf·m 91.2 to 108 lbf·ft
-------------------	-------------------	--

- | | |
|--------------------------|--------------------------|
| (1) ROPS | (4) Hazard Light RH |
| (2) Hazard Light LH | (5) Turn Signal Light RH |
| (3) Turn Signal Light LH | |

W1027220



Seat

1. Disconnect the seat switch connectors.
2. Remove the snap pins (2) and remove the seat (1).

- | | |
|----------|--------------|
| (1) Seat | (2) Snap Pin |
|----------|--------------|

W1014409

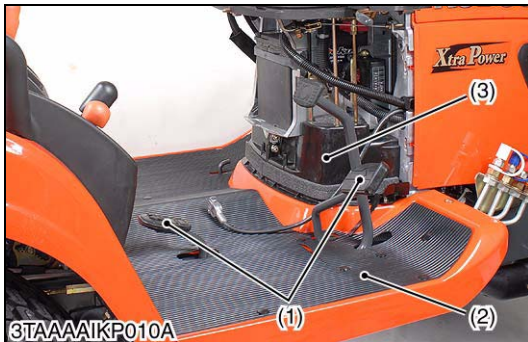

Speed Control Pedal and Step

1. Remove the valve covers (3).
2. Remove the speed control pedals (1) and step (2).

- | | |
|-------------------------|-----------------|
| (1) Speed Control Pedal | (3) Valve Cover |
| (2) Step | |

W1014726

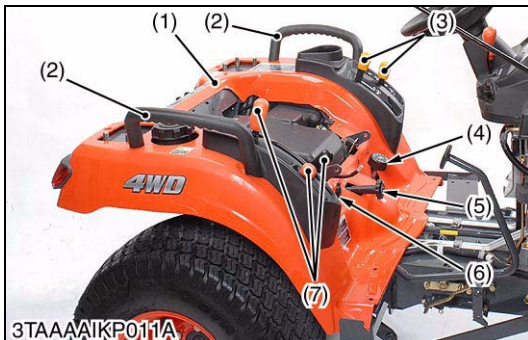

Lever Grips and Fender

1. Disconnect the electric outlet connector (6).
2. Remove the lowering speed adjusting knob (5) and cutting height adjusting dial knob (4).
3. Remove the lever grips (3) and lever guide mounting screw.
4. Remove the fender (1) with lever guide (2).

- | | |
|-----------------|--|
| (1) Fender | (4) Cutting Height Adjusting Dial Knob |
| (2) Lever Guide | (5) Lowering Speed Adjusting Knob |
| (3) Lever Grip | (6) Electric Outlet |

W1014865

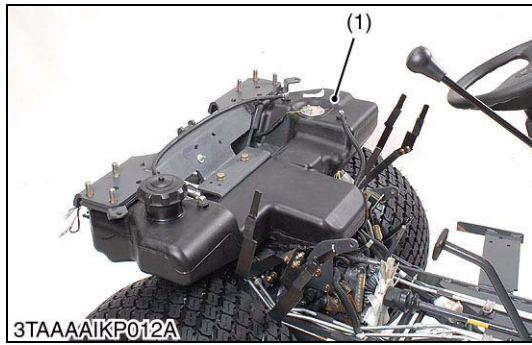

Fuel Tank

1. Drain the fuel.
2. Disconnect the lead wire from fuel level sensor and fuel hoses from the fuel tank (1).
3. Remove the fuel tank stays (2), (3) and cushions, then remove the fuel tank (1).
4. Remove the PTO cover (4).

(When reassembling)

Tightening torque	Fuel tank stay mounting bolt and nut	48 to 55 N·m 4.9 to 5.7 kgf·m 36 to 41 lbf·ft
-------------------	--------------------------------------	---

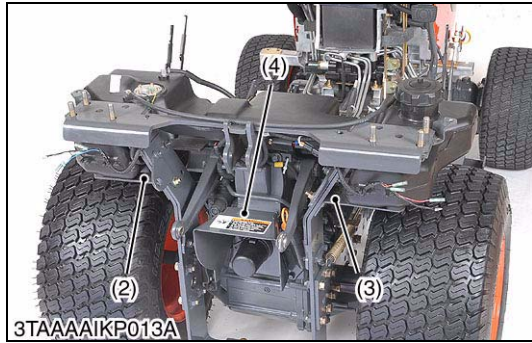

- | | |
|-----------------------|-----------------------|
| (1) Fuel Tank | (3) Fuel Tank Stay RH |
| (2) Fuel Tank Stay LH | (4) PTO Cover |

W1027629

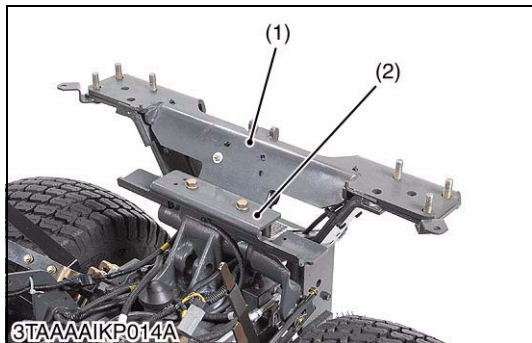

Fender Center Stay

1. Remove the fender bracket (2).
2. Remove the fender center stay (1).

(When reassembling)

Tightening torque	Fender bracket mounting bolt	124 to 147 N·m 12.6 to 15.0 kgf·m 91.2 to 108 lbf·ft
-------------------	------------------------------	--

- | | |
|------------------------|--------------------|
| (1) Fender Center Stay | (2) Fender Bracket |
|------------------------|--------------------|

W1027820

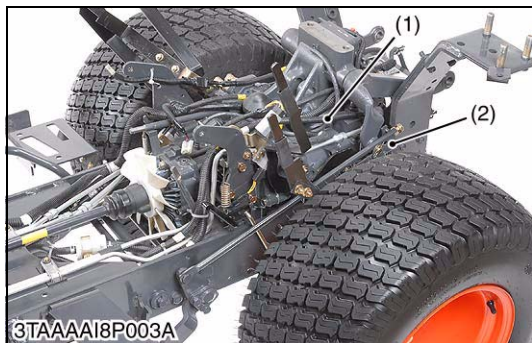

Mower Linkage and Wire Harness

1. Disconnect the mower linkage (2).
2. Remove the wire harness clamp and wire harness (1) move to the front side.

- | | |
|------------------|-------------------|
| (1) Wire Harness | (2) Mower Linkage |
|------------------|-------------------|

W1027951

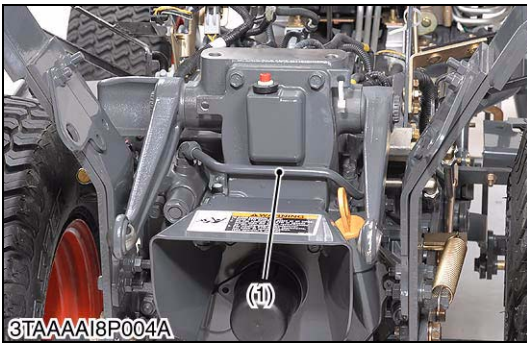

Hydraulic Cylinder Block

1. Remove the hydraulic pipe (1).
2. Remove the hydraulic cylinder block mounting bolt.
3. Remove the hydraulic cylinder block (2).

(When reassembling)

Tightening torque	Hydraulic cylinder block mounting bolt	40 to 44 N·m 4.0 to 4.5 kgf·m 29 to 32 lbf·ft
-------------------	--	---

(1) Hydraulic Pipe

(2) Hydraulic Cylinder Block

W1028149

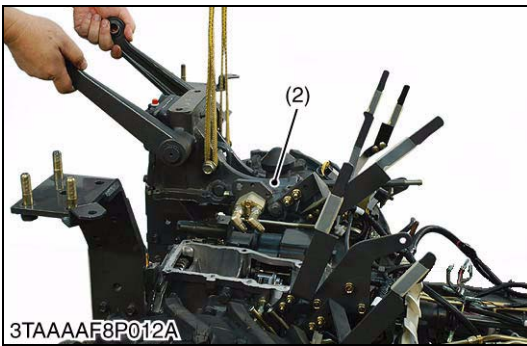

(2) Separating Hydraulic Pump



Battery

⚠ CAUTION

- When disconnecting the battery cables, disconnect the negative cable from the battery first. When connecting, connect the positive cable to the battery first.

1. Remove the under panel (1).
2. Disconnect the negative cable (3) from the battery.

(1) Under Panel

(3) Negative Cable

(2) Battery

W1028561



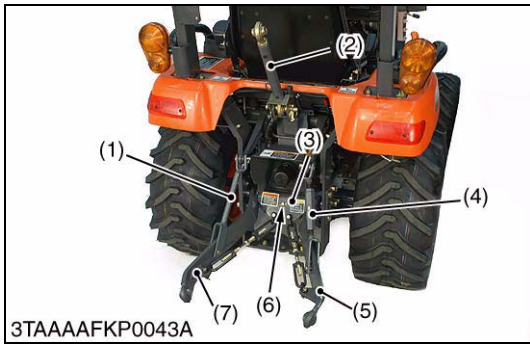

Lift Rod and Lower Link

1. Remove the top link (2).
2. Remove the stopper pin (6) and remove the check chain plate (3).
3. Move the bush (8) inside.
4. Move the shaft (9) to right side and remove the lower link as a unit.

- (1) Lift Rod LH
- (2) Top Link
- (3) Check Chain Plate
- (4) Lift Rod RH
- (5) Lower Link RH
- (6) Stopper Pin
- (7) Lower Link LH
- (8) Bush
- (9) Shaft

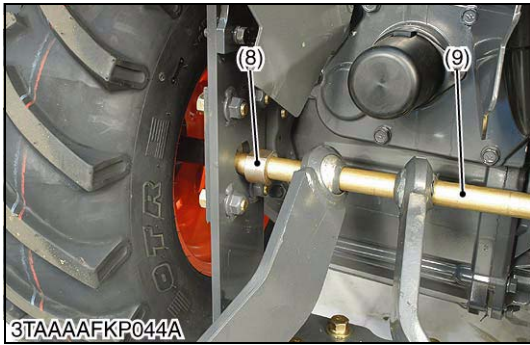

W1036365



Roll-Over Protective Structures (ROPS)

1. Disconnect the lead wires from the hazard lights (2), (4) and turn signal lights (3), (5).
2. Remove the ROPS mounting nuts, and remove the ROPS (1).

(When reassembling)

Tightening torque	ROPS mounting nut	124 to 147 N·m 12.6 to 15.0 kgf·m 91.2 to 108 lbf·ft
-------------------	-------------------	--

- (1) ROPS
- (2) Hazard Light LH
- (3) Turn Signal Light LH
- (4) Hazard Light RH
- (5) Turn Signal Light RH

W1028839



Seat

1. Disconnect the seat switch connectors.
2. Remove the snap pins (2) to remove the seat (1).

- (1) Seat
- (2) Snap Pin

W54879632

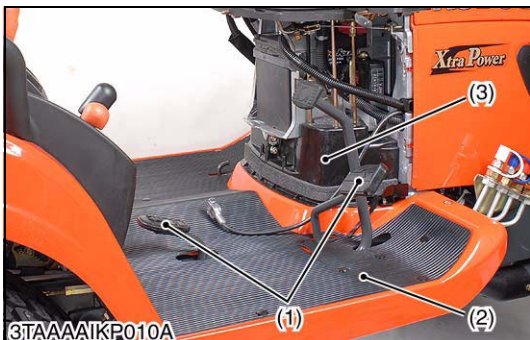

Speed Control Pedal and Step

1. Remove the valve covers (3).
2. Remove the speed control pedals (1) and step (2).

- (1) Speed Control Pedal
- (2) Step
- (3) Valve Cover

W85236974

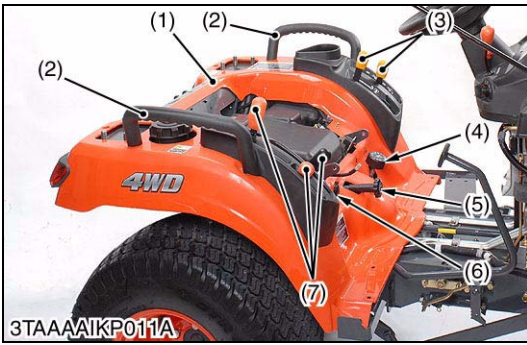

Lever Grips and Fender

1. Disconnect the electric outlet connector (6).
2. Remove the lowering speed adjusting knob (5) and cutting height adjusting dial knob (4).
3. Remove the lever grips (3) and lever guide mounting screw.
4. Remove the fender (1) with lever guide (2).

- | | |
|-----------------|--|
| (1) Fender | (4) Cutting Height Adjusting Dial Knob |
| (2) Lever Guide | (5) Lowering Speed Adjusting Knob |
| (3) Lever Grip | (6) Electric Outlet |

W1020932

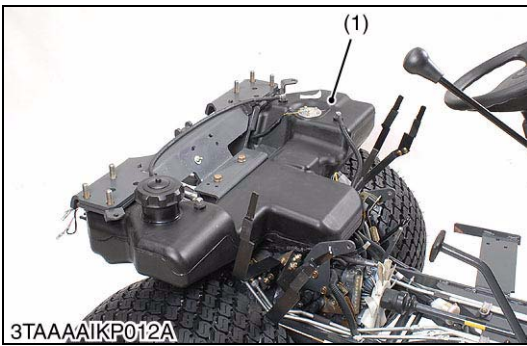

Fuel Tank

1. Drain the fuel.
2. Disconnect the lead wire from fuel level sensor and fuel hoses from the fuel tank (1).
3. Remove the fuel tank stays (2), (3) and cushions, then remove the fuel tank (1).
4. Remove the PTO cover (4).

(When reassembling)

Tightening torque	Fuel tank stay mounting bolt and nut	48 to 55 N·m 4.9 to 5.7 kgf·m 36 to 41 lbf·ft
-------------------	--------------------------------------	---

- | | |
|-----------------------|-----------------------|
| (1) Fuel Tank | (3) Fuel Tank Stay RH |
| (2) Fuel Tank Stay LH | (4) PTO Cover |

W1029258

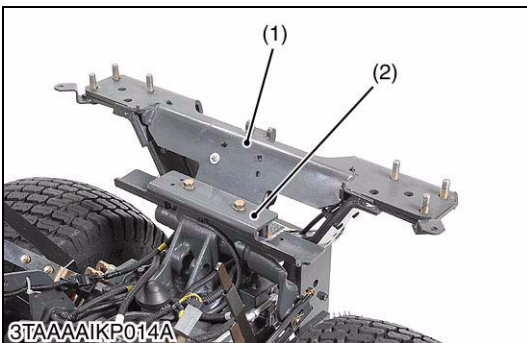
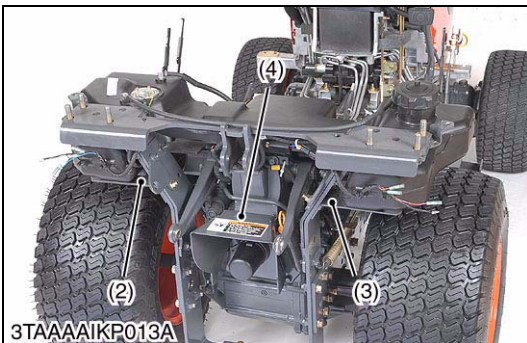

Fender Center Stay

1. Remove the fender bracket (2).
2. Remove the fender center stay (1).

(When reassembling)

Tightening torque	Fender bracket mounting bolt	124 to 147 N·m 12.6 to 15.0 kgf·m 91.2 to 108 lbf·ft
-------------------	------------------------------	--

- | | |
|------------------------|--------------------|
| (1) Fender Center Stay | (2) Fender Bracket |
|------------------------|--------------------|

W1029436

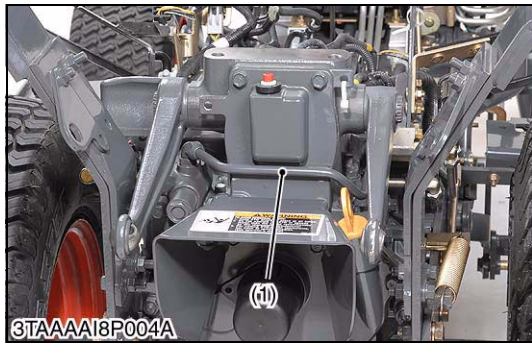

Hydraulic Pump

1. Disconnect the mower linkage (4).
2. Remove the lift arm LH (2).
3. Remove the hydraulic pipes (1).
4. Remove the hydraulic pump (3).

Tightening torque	Hydraulic pump mounting bolt (M6)	7.9 to 9.3 N·m 0.80 to 0.95 kgf·m 5.8 to 6.8 lbf·ft
	Hydraulic pump mounting bolt (M8)	18 to 20 N·m 1.8 to 2.1 kgf·m 13 to 15 lbf·ft

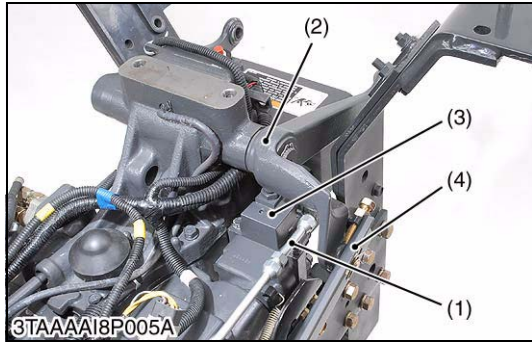

(When reassembling)

- Since the mounting bolt (5) is installed through the transaxle case to the transmission oil tank, seal the sealing tape to the mounting bolt (5) securely.

- | | |
|--------------------|------------------------------|
| (1) Hydraulic Pipe | (5) Bolt (M8) (Through Bolt) |
| (2) Lift Arm LH | (6) Bolt (M6) |
| (3) Hydraulic Pump | (7) Bolt (M8) |
| (4) Mower Linkage | |

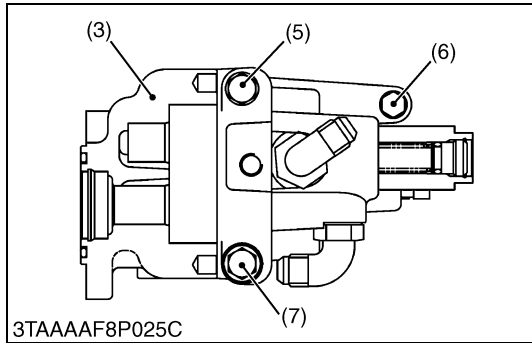

W1029558

[3] DISASSEMBLING AND ASSEMBLING

(1) Hydraulic Cylinder and Control Valve

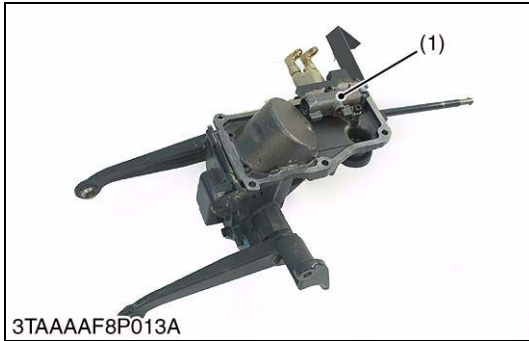

Control Valve

1. Remove the control valve (1).
2. Remove the internal snap ring (4) and draw out the spool (2).

- | | |
|-------------------|------------------------|
| (1) Control Valve | (3) Plain Washer |
| (2) Spool | (4) Internal Snap Ring |

W1030131

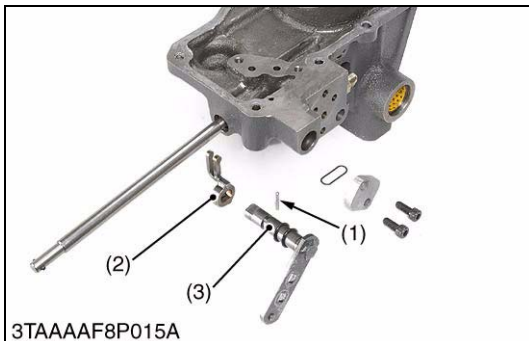
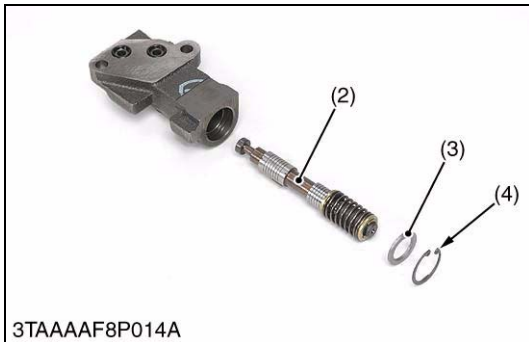

Control Valve Lever

1. Pull out the pin (1).
2. Remove the control valve lever (3) and arm (2).

- | | |
|---------|-------------------------|
| (1) Pin | (3) Control Valve Lever |
| (2) Arm | |

W1030453

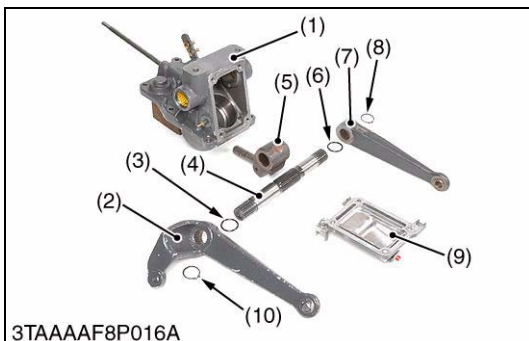

Lift Arm, Hydraulic Arm Shaft and Hydraulic Arm

1. Remove the external snap rings (8), (10), and remove the lift arms (2), (7).
2. Draw out the hydraulic arm shaft (4).

(When reassembling)

- Align the alignment marks of the hydraulic arm (2) and hydraulic arm shaft (4).
- Align the alignment marks of the lift arms (2), (7) and hydraulic arm shaft (4).
- Apply grease to the right and left bushings and O-rings.
- Take care not to damage the O-ring.

- | | |
|------------------------------|-------------------------|
| (1) Hydraulic Cylinder Block | (6) O-ring |
| (2) Lift Arm LH | (7) Lift Arm RH |
| (3) O-ring | (8) External Snap Ring |
| (4) Hydraulic Arm Shaft | (9) Cover |
| (5) Hydraulic Arm | (10) External Snap Ring |

W1031001

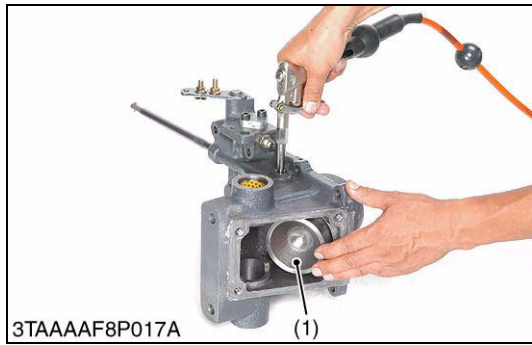

Hydraulic Piston

1. Inject the compressed air into the hydraulic cylinder, and take out the hydraulic piston (1).

(When reassembling)

- Take care not to damage the O-ring (3) and backup ring (2).
- Apply transmission fluid to the O-ring.
- Replace the O-ring if it is defective, worn or scratched, which may cause oil leakage.

- | | |
|----------------------|------------|
| (1) Hydraulic Piston | (3) O-ring |
| (2) Back-up Ring | |

W1031555

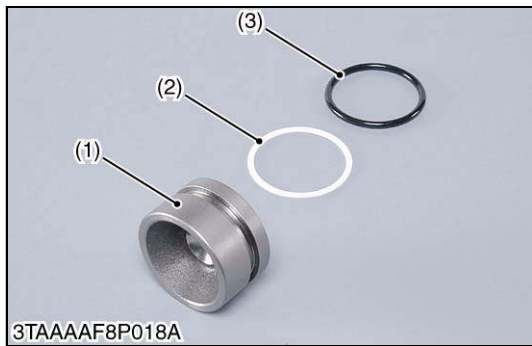

Lowering Speed Adjusting Valve

1. Remove the internal snap ring (5) and remove the lowering speed adjusting shaft (6).
2. Remove the ball (2) and spring (1).

(When reassembling)

- Take care not to damage the O-rings.

- | | |
|------------|------------------------------------|
| (1) Spring | (4) Stopper |
| (2) Ball | (5) Internal Snap Ring |
| (3) O-ring | (6) Lowering Speed Adjusting Shaft |

W1032074

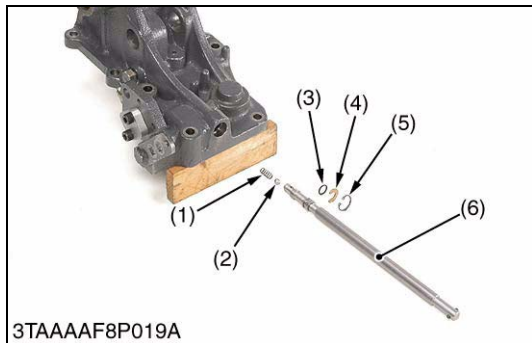

(2) Mower Lift Linkage

Disassembling Mower Linkage

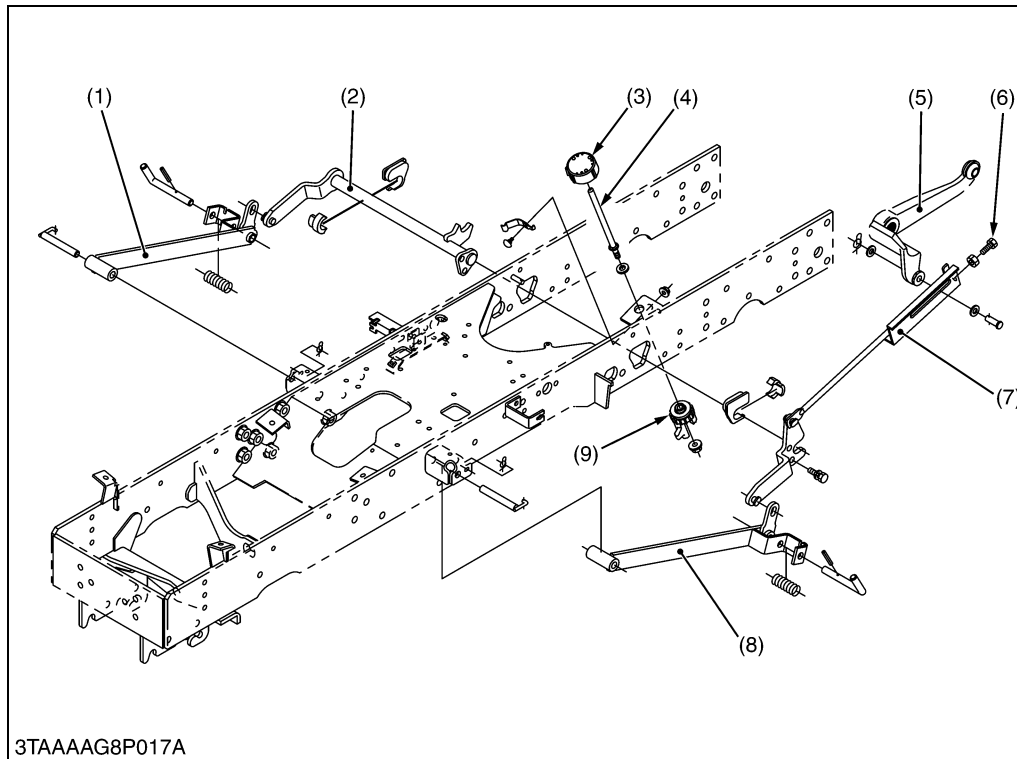

- (1) Mower Rear Link, RH
- (2) Lift Link Rear, RH
- (3) Cutting Height Adjusting Dial Knob
- (4) Cutting Height Adjusting Rod
- (5) Lift Arm, LH
- (6) Link Adjusting Bolt
- (7) Lift Link Rear, LH
- (8) Mower Rear Link, LH
- (9) Adjusting Cam

W1032616

3TAAAAG8P017A

1. Remove the clevis pin and remove the lift link rear LH (7).
2. Remove the pin and remove the mower rear links (1), (8).
3. Remove both side of boss and remove the lift link rear RH (2).
4. Remove the cutting height adjusting dial knob (3).
5. Remove the nut and remove the adjusting cam (9) and cutting height adjusting rod (4).

(When reassembling)

- Adjust the length of the link adjusting bolt. (Refer to page 5-S6.)

W1032750

[4] SERVICING

(1) Hydraulic Pump

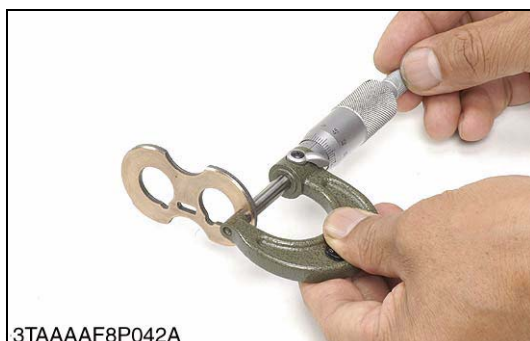
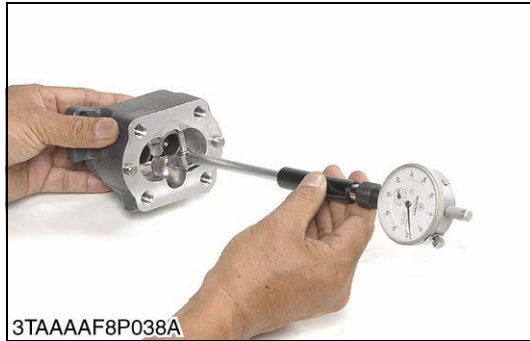

Clearance between Tip of Gear Tooth and Casing

1. Measure the gear O.D. with an outside micrometer.
2. Measure the casing I.D. with a cylinder gauge and calculate the clearance.
3. If the clearance exceeds the allowable limit, replace the assembly.

Clearance between tip of gear tooth and casing	Allowable limit	0.15 mm 0.0059 in.
--	-----------------	-----------------------

Gear O.D.	Factory spec.	33.520 to 33.530 mm 1.3197 to 1.3200 in.
-----------	---------------	---

Case I.D.	Factory spec.	33.570 to 33.577 mm 1.3217 to 1.3219 in.
-----------	---------------	---

W1015764

Clearance between Bushing and Shaft

1. Measure the gear shaft O.D. with an outside micrometer.
2. Measure the bushing I.D. with a cylinder gauge and calculate the clearance.
3. If the clearance exceeds the allowable limit, replace it.

Clearance between bushing and shaft	Factory spec.	0.020 to 0.091 mm 0.00079 to 0.0035 in.
	Allowable limit	0.12 mm 0.0047 in.

Shaft O.D.	Factory spec.	14.970 to 14.980 mm 0.58937 to 0.58976 in.
------------	---------------	---

Bushing I.D.	Factory spec.	15.000 to 15.061 mm 0.59056 to 0.59295 in.
--------------	---------------	---

W1015972

Side Plate Thickness

1. Measure the side plate thickness with an outside micrometer.
2. If the thickness is less than the allowable limit, replace it.

Side plate thickness	Factory spec.	2.48 to 2.50 mm 0.0977 to 0.0984 in.
	Allowable limit	2.40 mm 0.094 in.

W1016194

(2) Hydraulic Cylinder



Hydraulic Cylinder Bore

1. Check the cylinder internal surface for scoring or damage.
2. Measure the cylinder I.D. with a cylinder gauge.
3. If the measurement exceeds the allowable limit, replace the hydraulic cylinder block.

Cylinder I.D.	Factory spec.	80.05 to 80.15 mm 3.152 to 3.155 in.
	Allowable limit	80.20 mm 3.157 in.

W10171300



Hydraulic Arm Shaft Bushing

1. Visually inspect the DX bushings for signs of wear or damage. (The DX bushing tends to show concentrated wear.)
2. If the DX bushing is worn beyond the alloy thickness (**A**), replace it.

(Reference)

Hydraulic arm shaft bushing	Alloy thickness (A)	0.57 mm 0.022 in.
-----------------------------	------------------------------	----------------------

Hydraulic arm shaft	LH	O.D.	31.925 to 31.950 mm 1.2569 to 1.2578 in.
	RH	O.D.	29.925 to 29.950 mm 1.1782 to 1.1791 in.

A : Alloy Thickness

L : Outside Diameter

W1016329

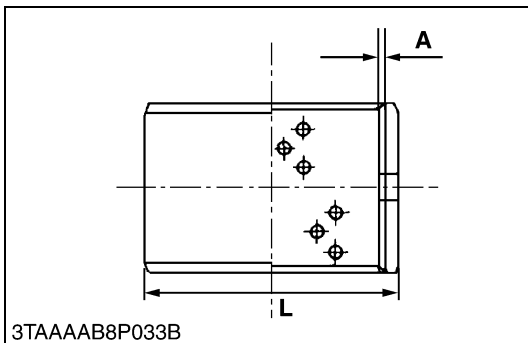

6 ELECTRICAL SYSTEM

MECHANISM

CONTENTS

1. WIRING DIAGRAM	6-M1
2. STARTING SYSTEM	6-M3
[1] MAIN SWITCH POSITION	6-M3
[2] SAFETY SWITCH	6-M4
[3] OPERATOR PRESENCE CONTROL (OPC)	6-M5
3. CHARGING SYSTEM	6-M6
[1] ELECTRICAL CIRCUIT	6-M6
[2] IC REGULATOR (3P CONNECTOR TYPE)	6-M7
4. LIGHTING SYSTEM	6-M8
5. GAUGES	6-M9
[1] ELECTRICAL CIRCUIT	6-M9
[2] HOUR AND TACHOMETER	6-M10
[3] FUEL LEVEL GAUGE	6-M10
[4] WATER TEMPERATURE GAUGE	6-M10
6. OTHERS	6-M11
[1] DC OUTLET	6-M11

1. WIRING DIAGRAM

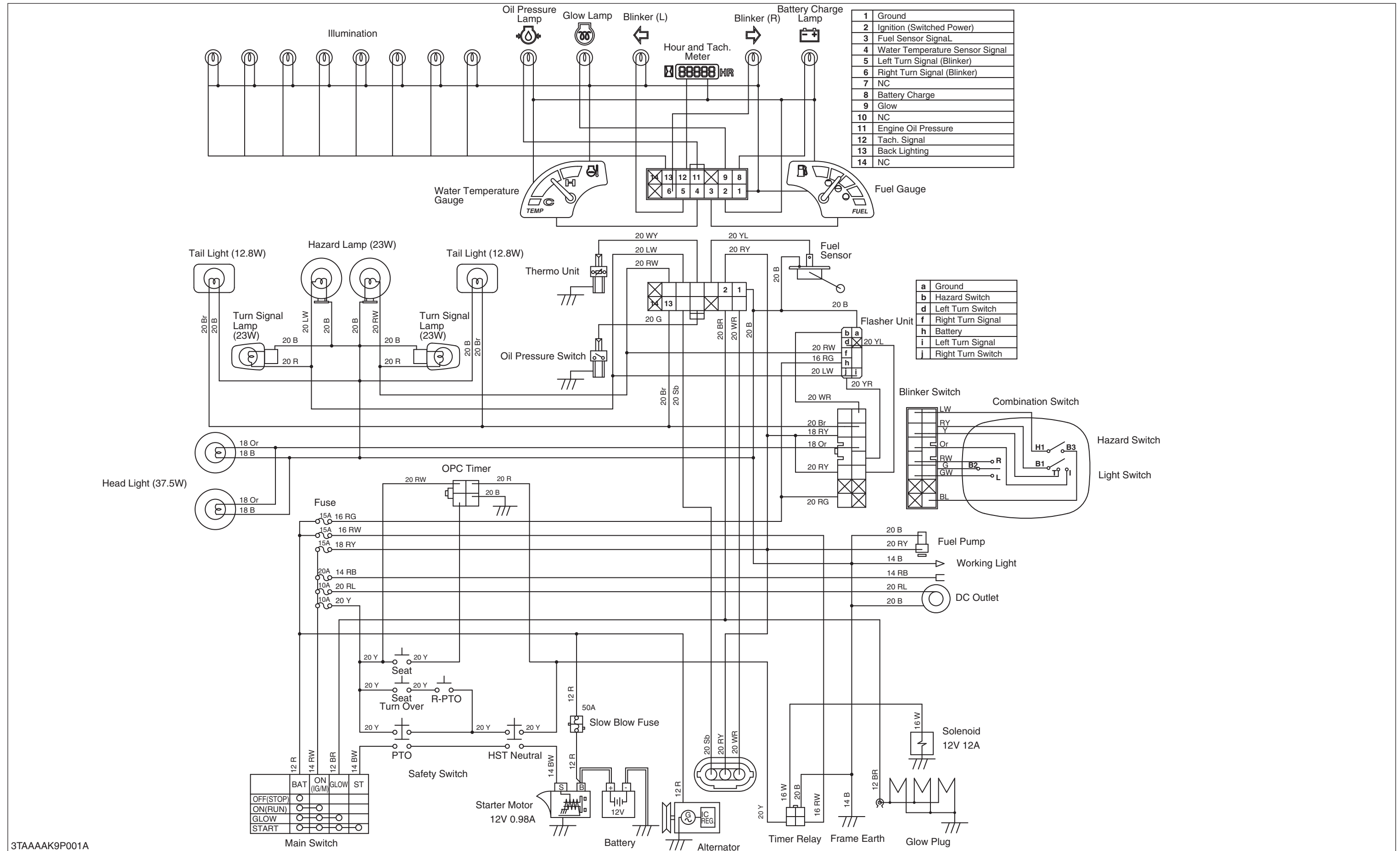

3TAAAK9P001A

6-M1

Color of Wiring

W White	WR White / Red	BW Black / White
R Red	WY White / Yellow	BR Black / Red
L Blue	RB Red / Black	GW Green / White
P Pink	RW Red / White	YR Yellow / Red
B Black	RG Red / Green	YL Yellow / Blue
Br Brown	RY Red / Yellow	LW Blue / White
Sb Sky Blue		

W1019456

2. STARTING SYSTEM

[1] MAIN SWITCH POSITION

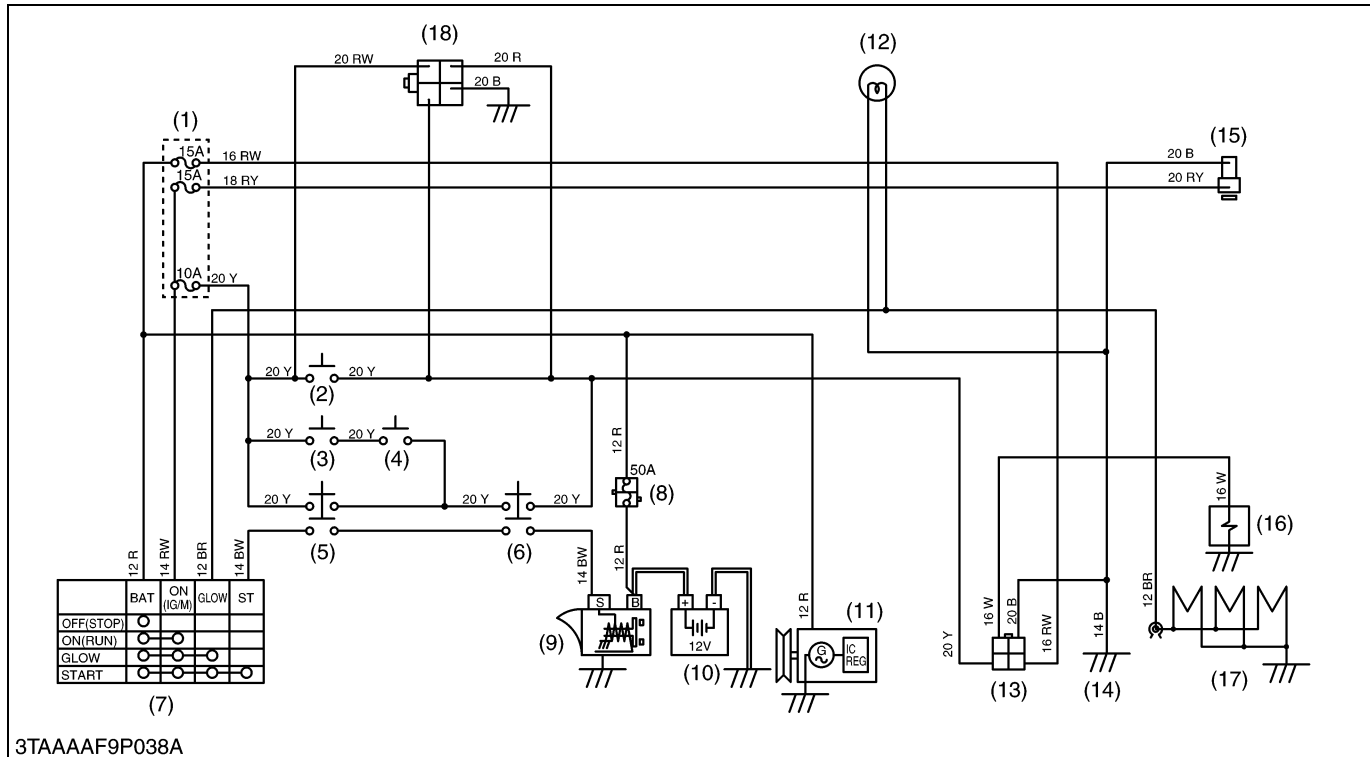

- | | | | |
|--------------------|--------------------|------------------|----------------|
| (1) Fuse | (6) HST Neutral | (11) Alternator | (15) Fuel Pump |
| (2) Seat | (7) Main Switch | (12) Glow Lamp | (16) Solenoid |
| (3) Seat Turn Over | (8) Slow Blow Fuse | (13) Timer Relay | (17) Glow Plug |
| (4) R-PTO | (9) Starter Motor | (14) Frame Earth | (18) OPC Timer |
| (5) PTO | (10) Battery | | |

When the main switch (7) is turned to the **GLOW** position, the terminal **BAT** is connected to the terminal **ON** and **AC**. The glow plugs (17) become red-hot, and the preheat indicator lamp also lights on while preheating.

When the main switch is then turned to the **START** position with the safety switches on, the terminal **BAT** is connected to the terminals **GLOW** and **ST**. Consequently, battery (10) current flows to the starter motor (9) and start the engine.

The main switch automatically returns to the **ON** position, the terminal **BAT** is connected only to the terminal **GLOW**, thereby causing the starting circuit to be opened, stopping the starter motor.

When the main switch turned from the **ON** position to the **OFF** position, the fuel cut-off solenoid moves the fuel injection pump control rack to the “**No Fuel Injection**” position and stops the engine.

The BX2660 tractor (with the OPC timer (18)) equipped the operator presence control (OPC) system which automatically stops the engine in approximately one second when operator stands from the seat while shifting the PTO clutch lever and range gear shift lever

[2] SAFETY SWITCH

This switch is electrically closed in normal condition (normally closed type). The switch operates as sensor detecting and transmitting the position of HST pedal, PTO lever, independent PTO lever, and seat to engine stop solenoid.

Type of Switch	Safety Switch Name	Number of Switch Contact
Normal open type	Seat switch	1
	Seat turn over switch	1
	PTO shift lever switch	1
	Independent PTO Lever Switch (Rear PTO Switch)	2
	HST pedal neutral switch	2

W1014916

Lever / Pedal Position, Engine Condition and Switch Condition

No.	Lever / Pedal Position					Engine Condition		
	HST Pedal Neutral switch; Neutral: ON Forward or reverse: OFF	Independent PTO Lever Switch; I-PTO engaged: ON I-PTO disengaged: OFF	PTO Shift Lever Switch; R-PTO Selected: ON M-PTO or M and R-PTO Selected: OFF	Operator's Seat Switch; Occupied: ON Off Seat or Vacant: OFF	Seat Turn Over Switch; Normal position: OFF Turn over: ON	Engine Stopping	Engine Starting	
1	Neutral Position: ON	Disengaged: OFF	R-PTO Selected: ON	On Seat: ON	Normal: OFF	Running	Can Start	
2				Off Seat: OFF	Normal: OFF			
3			M-PTO or M and R-PTO Selected: OFF	On Seat: ON	Normal: OFF			
4				Off Seat: OFF	Normal: OFF			
5				Turn Over: ON	On Seat: ON			Normal: OFF
6					Off Seat: OFF			Normal: OFF
7		Engaged: ON	R-PTO Selected: ON	On Seat: ON	Normal: OFF	Running	Can not Start	
8				Off Seat: OFF	Normal: OFF	Stop		
9			M-PTO or M and R-PTO Selected: OFF	On Seat: ON	Normal: OFF	Running		
10				Off Seat: OFF	Normal: OFF	Stop		
11				Turn Over: ON	On Seat: ON	Normal: OFF		Running
12					Off Seat: OFF	Normal: OFF		Stop
13	Forward (OFF) or Reverse (OFF)	Disengaged: OFF	R-PTO Selected: ON	On Seat: ON	Normal: OFF	Running		
14				Off Seat: OFF	Normal: OFF	Stop		
15			M-PTO or M and R-PTO Selected: OFF	On Seat: ON	Normal: OFF	Running		
16				Off Seat: OFF	Normal: OFF	Stop		
17				Turn Over: ON	On Seat: ON	Normal: OFF		Running
18					Off Seat: OFF	Normal: OFF		Stop
19		Engaged: ON	R-PTO Selected: ON	On Seat: ON	Normal: OFF	Running		
20				Off Seat: OFF	Normal: OFF	Stop		
21			M-PTO or M and R-PTO Selected: OFF	On Seat: ON	Normal: OFF	Running		
22				Off Seat: OFF	Normal: OFF	Stop		
23				Turn Over: ON	On Seat: ON	Normal: OFF	Running	
24					Off Seat: OFF	Normal: OFF	Stop	

W1015145

[3] OPERATOR PRESENCE CONTROL (OPC)

The BX Tractor equips operator presence control (OPC) system which automatically stops the engine when operator stands up from the operator's seat while shifting the PTO lever or the speed control pedal.

Tractor without the OPC timer stops quickly and tractor with the OPC timer stops in approximately one second when standing up from the seat.

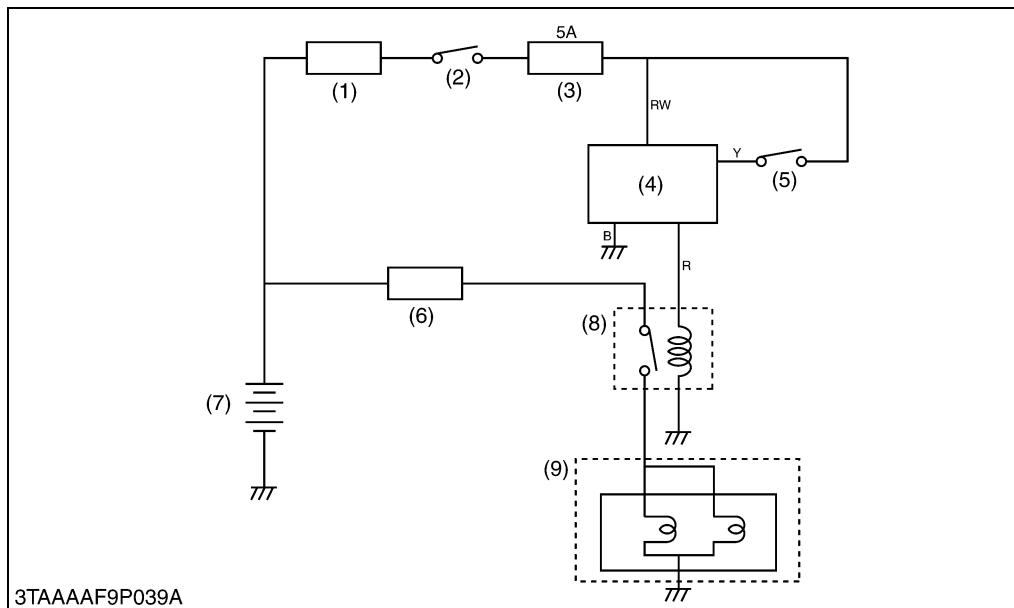

- (1) Slow Blow Fuse
 - (2) Main Switch
 - (3) Fuse (10A)
 - (4) OPC Timer
 - (5) Seat Switch (From Seat Switch **ON** or **OFF**)
 - (6) Fuse
 - (7) Battery
 - (8) Engine Stop Solenoid Timer Relay
 - (9) Engine Stop Solenoid
- W1025506



■ Electrical Circuit (Tractor with OPC Timer)

General electrical circuit of the tractor OPC timer is shown in the figure.

1. When sitting on the operator's seat in the state of the main switch "**ON**", the battery voltage passes to the seat switch and the OPC timer (4), and maintain the solenoid relay (8).
2. When standing up from the operator's seat, the circuit from the seat switch to the OPC timer is cut. However, if the PTO lever (or the speed control pedal) are set at "**Neutral**" position, the circuit from the battery to the solenoid relay (8) is formed with the PTO switch (or HST switch).
3. When standing up from the operator's seat while shifting the levers, the circuit from the battery to the solenoid relay (8) is cut, and the engine is stopped by function of the solenoid (9).

■ Seat Switch

The seat switch has two positions.

When the operator's seat is occupied, the switch contact point is at "**ON**" position. When the operator's seat is not occupied, its contact point is at "**OFF**" position.

■ OPC Timer

OPC timer is located electrically at between the seat switch (5) and the solenoid relay (8).

When the current supply from the seat switch (5) is cut, the OPC timer (4) adopted for the OPC system has maintained the state of "**ON**" position for approximately one second.

W1025648

[2] IC REGULATOR (3P CONNECTOR TYPE)

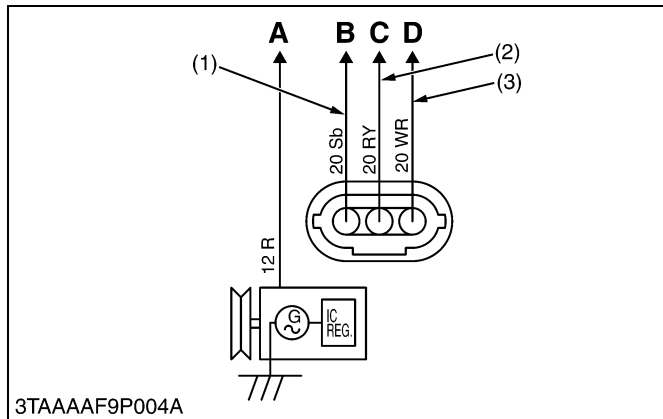

3P connector is connected to the IC regulator. **3P** connector consists of three leads, Sb (Sky Blue) lead (1), RY (Red / Yellow) lead (2), and WR (White / Red) lead (3).

Sb (Sky Blue) lead (1) is a lead to transmit the pulse from the alternator to hour meter and tachometer. When turning on the main switch to "ON" position, the hour meter indicates operated hours.

While the engine runs, the tachometer indicates the present engine revolutions.

RY (Red / Yellow) lead (2) is a lead to chassis.

WR (White / Red) lead (3) is a lead to the charge lamp.

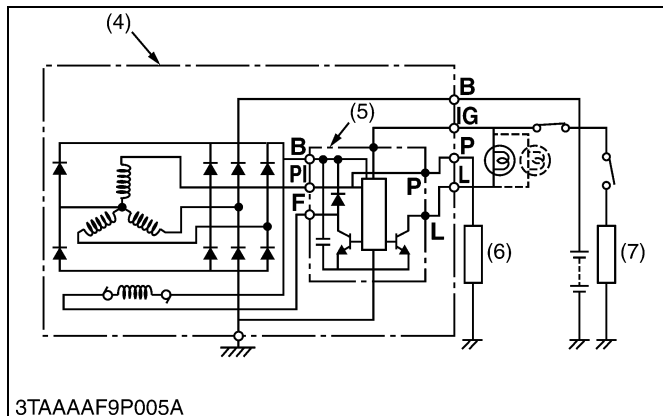

- (1) Sb (Sky Blue) Lead
- (2) RY (Red / Yellow) Lead
- (3) WR (White / Red) Lead
- (4) Alternator Assembly
- (5) IC Regulator
- (6) Load
- (7) Load

- A : To Main Switch**
- B : To Hour Meter and Tachometer**
- C : To Ground**
- D : To Charge Lamp**

W1013535

4. LIGHTING SYSTEM

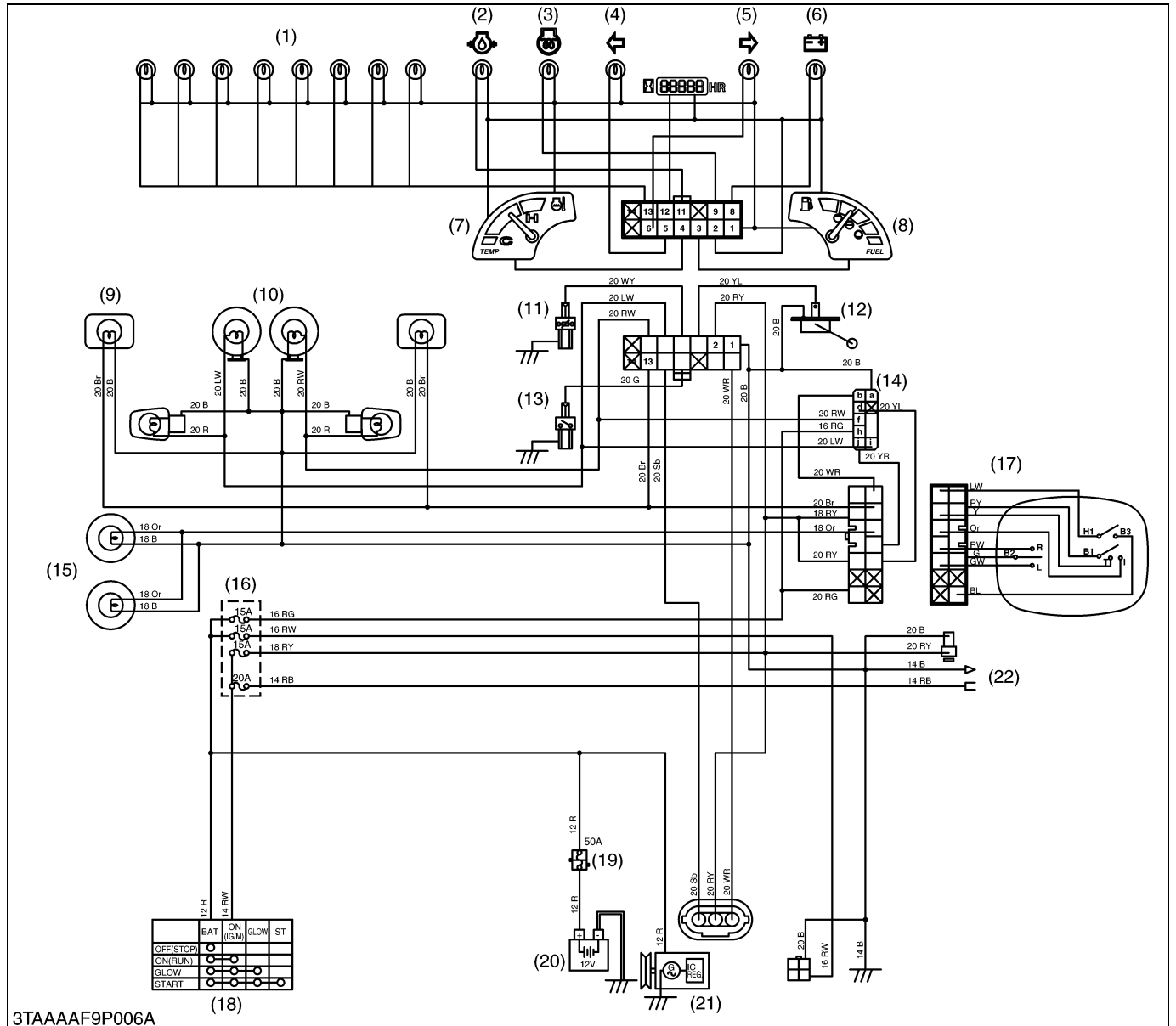

3TAAAF9P006A

- | | | | |
|-------------------------|-----------------------------|--------------------------|---------------------|
| (1) Illumination Light | (7) Water Temperature Gauge | (13) Oil Pressure Switch | (18) Main Switch |
| (2) Oil Pressure Lamp | (8) Fuel Gauge | (14) Flasher Unit | (19) Slow Blow Fuse |
| (3) Glow Lamp | (9) Tail Light (12.8W) | (15) Head Light (37.5W) | (20) Battery |
| (4) Blinker (Left) | (10) Hazard Lamp (23W) | (16) Fuse | (21) Alternator |
| (5) Blinker (Right) | (11) Thermo Unit | (17) Combination Switch | (22) Working Light |
| (6) Battery Charge Lamp | (12) Fuel Sensor | | |

The lighting system consists of main switch, head light switch, turn signal light switch, hazard switch, head lights, turn signal lights, tail lights, and etc..

5. GAUGES

[1] ELECTRICAL CIRCUIT

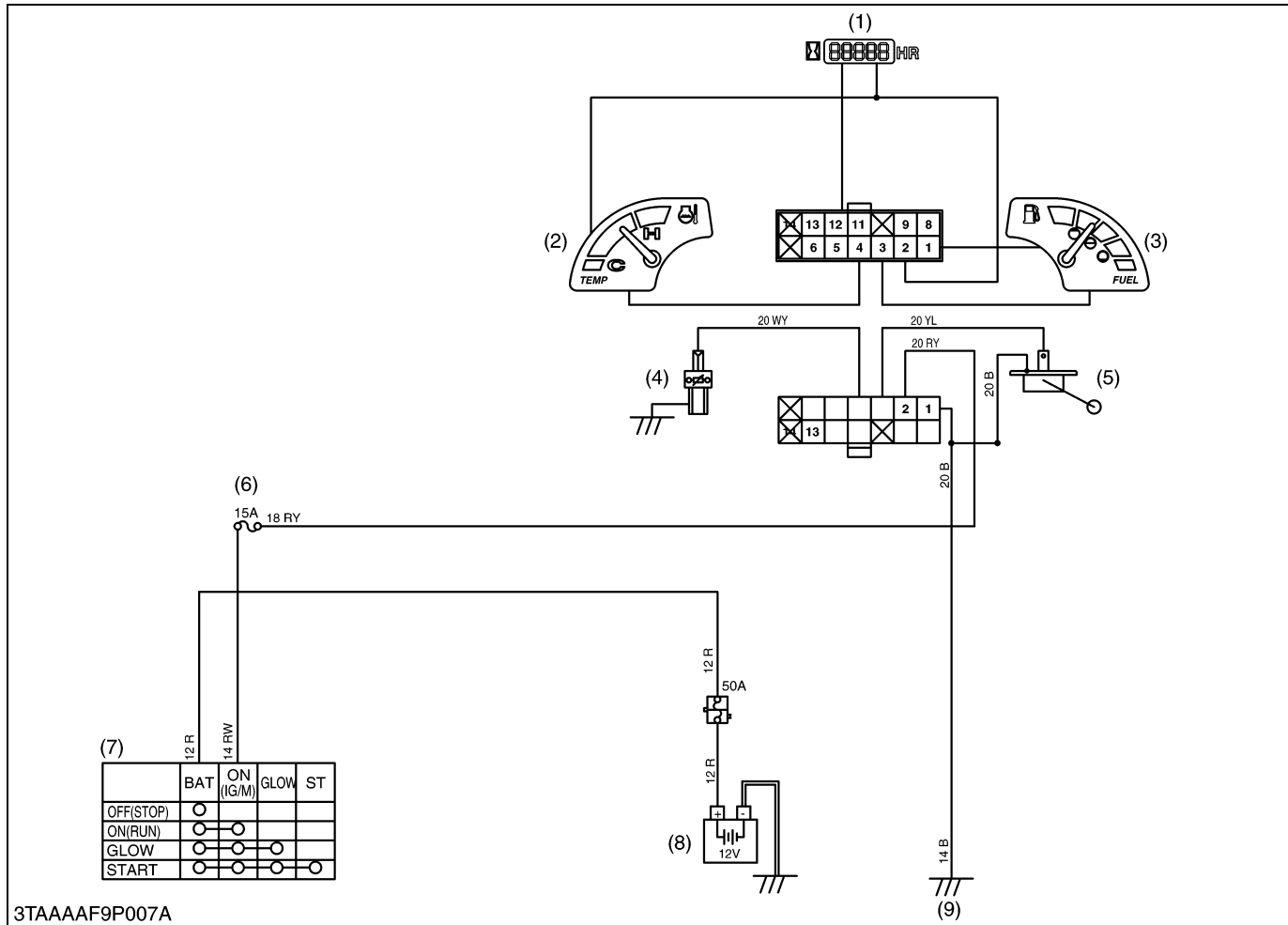

- (1) Hour and Tachometer
- (2) Water Temperature Gauge
- (3) Fuel Gauge
- (4) Thermo Unit
- (5) Fuel Sensor
- (6) Fuse
- (7) Main Switch
- (8) Battery
- (9) Frame Earth

The fuel quantity is indicated by the fuel gauge. The coolant temperature is indicated by the water temperature gauge.

[2] HOUR AND TACHOMETER

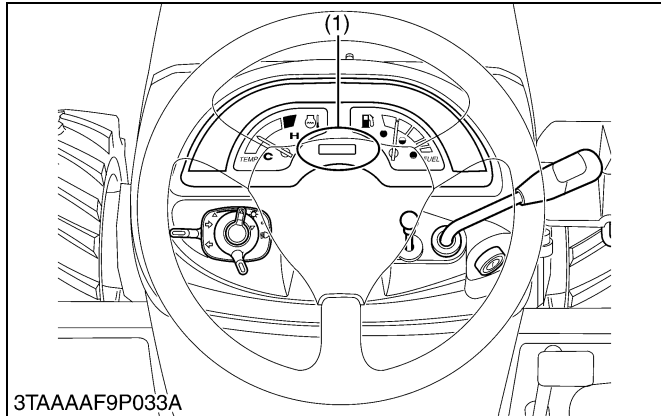

The electrical hour meter and tachometer is equipped on the meter panel.

This meter indicates the operated hours when the main switch is turned to "ON" position.

After starting the engine, this meter indicates the present engine revolution.

The meter picks up the voltage from the IC regulator located in the alternator.

The IC regulator sends a signal of the engine revolution to the meter.

The meter calculates the signal. It changes and indicates the signal to the engine revolution in cooperation with the voltage.

- (1) Electrical Hour Meter and Tachometer

W1013678

[3] FUEL LEVEL GAUGE

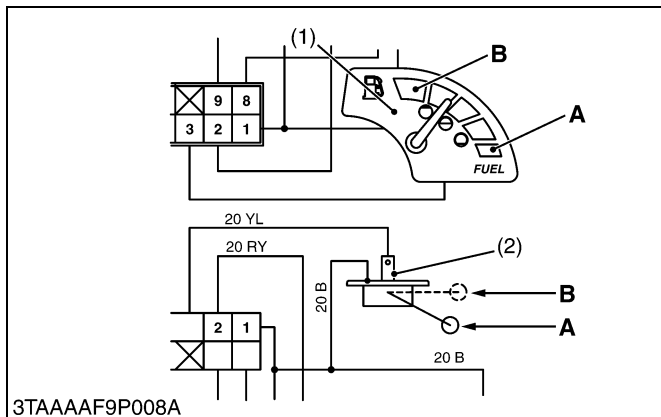

Fuel level gauge and fuel level sensor are connected by the wiring.

Fuel level gauge detects the resistance from the fuel level sensor.

Fuel level gauge indicates the fuel level in the fuel tank.

The relationship between the resistance of the fuel level sensor and the fuel level gauges is as follows.

Resistance of Fuel Level Sensor	Reading on Fuel Level Gauge
Approx. 110 Ω	Empty
Approx. 3 Ω	Full

- (1) Fuel Level Gauge **A : Empty**
 (2) Fuel Level Sensor **B : Full**

[4] WATER TEMPERATURE GAUGE

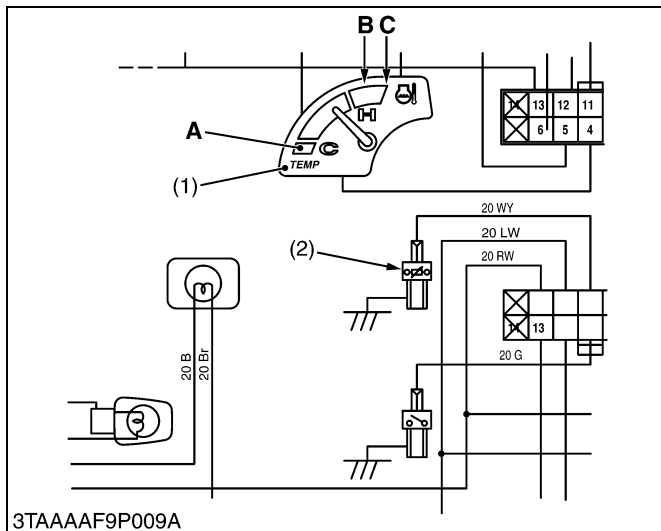

Water temperature gauge is located on the meter panel board.

The water temperature gauge and the thermo unit are connected by the wiring.

The water temperature gauge detects the resistance from the thermo unit.

The water temperature gauge indicates the coolant temperature in the engine cylinder head.

The relationship between the resistance of thermo unit and reading on the water temperature gauge is as follows.

Resistance of Thermo Unit	Reading on Water Temperature gauge
Approx. 220 Ω	Min.
Approx. 70 Ω	Start of red
Approx. 3 Ω	Max.

- (1) Water Temperature Gauge **A : Min.**
 (2) Thermo Unit **B : Start of Red**
 C : Max.

6. OTHERS

[1] DC OUTLET



DC outlet is equipped to this machine.
 The capacity of the DC outlet is 12 V / 120 W.
 The electrical device as a CD player, a mobile phone battery charger can be used to the DC outlet.
 The DC outlet (1) consists of the DC outlet body (3) and the cover (4).

- (1) DC Outlet
- (2) Electrical Device
- (3) DC Outlet Body
- (4) Cover

RL : Red / Blue Lead
B : Black Lead

W1021891

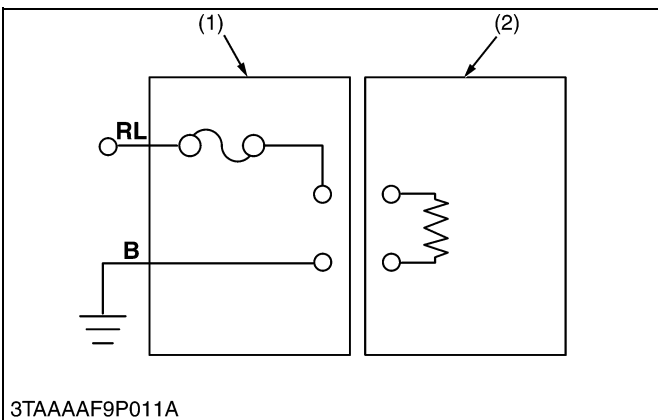

SERVICING

CONTENTS

1. TROUBLESHOOTING	6-S1
2. SERVICING SPECIFICATIONS	6-S5
3. TIGHTENING TORQUES	6-S6
4. CHECKING, DISASSEMBLING AND SERVICING.....	6-S7
[1] CHECKING AND ADJUSTING	6-S7
(1) Battery.....	6-S7
(2) Main Switch.....	6-S9
(3) Starter	6-S10
(4) Glow Plug.....	6-S10
(5) Safety Switch	6-S11
(6) Operator Presence Control (OPC) Switch	6-S13
(7) Fuel Pump.....	6-S15
(8) Engine Stop Solenoid	6-S15
(9) Timer Relay.....	6-S15
(10)Charging System	6-S16
(11)Alternator	6-S16
(12)Combination Switch	6-S18
(13)Gauge	6-S25
(14)DC Outlet.....	6-S27
[2] DISASSEMBLING AND ASSEMBLING.....	6-S28
(1) Starter	6-S28
(2) Alternator	6-S28
[3] SERVICING	6-S29
(1) Starter	6-S29
(2) Alternator	6-S31

1. TROUBLESHOOTING

FUSE AND WIRING

Symptom	Probable Cause	Solution	Reference Page
All Electrical Equipments Do Not Operate	Battery discharged or defective	Recharge or replace	G-17
	Battery positive cable disconnected or improperly connected	Repair or replace	–
	Battery negative cable disconnected or improperly connected	Repair or replace	–
	Slow blow fuse blown	Replace	G-30
Fuse Blown Frequently	Short-circuited	Repair or replace	–

W10143220

BATTERY

Battery Discharges Too Quickly	Battery defective	Replace	6-S7
	Alternator defective	Repair or replace	6-S28, S31
	IC Regulator defective	Replace	6-S26, S31
	Wiring harness disconnected or improperly connected (between battery positive terminal and regulator B terminal)	Repair or replace	–
	Cooling fan belt slipping	Adjust tension	G-20

W10137180

STARTING SYSTEM

Starter Motor Does Not Operate	Battery discharged or defective	Recharge or replace	G-17
	Slow blow fuse blown	Replace	G-30
	Safety switch improperly adjusted or defective	Repair or replace	6-S11
	Wiring harness disconnected or improperly connected (between main switch 50 terminal and safety switches, between safety switches and starter motor, between battery positive terminal and starter motor)	Repair or replace	–
	Starter motor defective	Repair or replace	6-S28
	Main switch defective	Replace	6-S9
Engine Does Not Stop When Main Switch is Turned OFF	Fuse blown (15 A)	Replace	G-30
	Wiring harness disconnected or improperly connected (between main switch AC terminal and engine stop solenoid)	Repair or replace	–
	Engine stop solenoid defective	Replace	6-S15
	Timer relay defective	Replace	6-S15
Engine Does Not Start	Engine stop solenoid defective	Replace	6-S15
	Timer relay defective	Replace	6-S15

W10137180

OPERATOR PRESENCE CONTROL (OPC)

Symptom	Probable Cause	Solution	Reference Page
Engine Does Not Stop	Solenoid fuse blown (15A)	Replace	G-30
	Engine stop solenoid relay defective	Replace	6-S15
	Engine stop solenoid defective	Replace	6-S15
	PTO shift lever switch defective	Adjust or replace	6-S11
	Independent PTO lever switch defective	Adjust or replace	6-S12
	HST pedal switch defective	Adjust or replace	6-S12
	Wiring harness disconnected or improperly connected (between key stop solenoid relay and engine stop solenoid, between engine stop solenoid relay and battery positive terminal)	Repair or replace	–
Starter Motor Does Not Operate	Solenoid fuse blown (15A)	Replace	G-30
	Engine stop solenoid defective	Replace	6-S15
	Engine stop solenoid relay defective	Replace	6-S15
	Seat switch or seat turn over switch defective	Adjust or replace	6-S13
	PTO shift lever switch defective	Adjust or replace	6-S11
	Independent PTO lever switch defective	Adjust or replace	6-S12
	HST pedal switch defective	Adjust or replace	6-S12
	Wiring harness disconnected or improperly connected (between key stop solenoid relay and engine stop solenoid, between engine stop solenoid relay and battery positive terminal)	Repair or replace	–
Engine Stops When HST Pedal is Pushed in Forward or in Reverse	Wrong wiring of seat switch and seat turn over switch	Proper Wiring	6-S13
Engine Suddenly Stops	Seat reverse switch	Adjust the switch position	6-S13

W10236630

CHARGING SYSTEM

Charging Lamp Does Not Light when Main Switch is Turned ON	Fuse blown (15 A)	Replace	G-30
	Wiring harness disconnected or improperly connected (between main switch AC terminal and panel board, between panel board and dynamo)	Repair or Replace	–
	Alternator defective	Repair or Replace	6-S28, S31
	IC regulator defective	Replace	–
Charging Lamp Does Not Go Off When Engine is Running	Wiring harness disconnected or improperly connected (between main switch 30 terminal and dynamo, between panel board and dynamo)	Repair or Replace	–
	Alternator defective	Repair or Replace	6-S28, S31
	IC regulator defective	Replace	6-S26, S31

W10135800

LIGHTING SYSTEM

Symptom	Probable Cause	Solution	Reference Page
Head Light Does Not Light	Fuse blown (15 A)	Replace	G-30
	Bulb blown	Replace	G-31
	Wiring harness disconnected or improperly connected (between main switch AC terminal and head light switch, between head light switch and head light)	Repair or Replace	–
Tail Light Does Not Light	Fuse blown (15 A)	Replace	G-30
	Bulb blown	Replace	G-31
	Wiring harness disconnected or improperly connected (between main switch AC terminal and head light switch, between head light switch and tail light)	Repair or Replace	–
Illumination Light Does Not Light	Fuse blown (15 A)	Replace	G-30
	Bulb blown	Replace	–
	Wiring harness disconnected or improperly connected (between main switch AC terminal and head light switch, between head light switch and illumination light)	Repair or Replace	–
Hazard Light Does Not Light	Fuse blown (15 A)	Replace	G-30
	Bulb blown	Replace	G-31
	Wiring harness disconnected or improperly connected	Repair or Replace	–
	Flasher unit defective	Replace	6-S22
	Hazard switch defective	Replace	6-S21
Hazard Indicator Lamp Does Not Light	Bulb blown	Replace	–
	Wiring harness disconnected or improperly connected	Repair or Replace	–
Hazard Light Does Not Flicker	Flasher unit defective	Replace	6-S22
Turn Signal Light Does Not Light	Fuse blown (15 A)	Replace	G-30
	Bulb blown	Replace	G-31
	Wiring harness disconnected or improperly connected	Repair or Replace	–
	Flasher unit defective	Replace	6-S22
	Blinker switch defective	Replace	6-S21
Turn Signal Light Indicator Lamp Does Not Light	Bulb blown	Replace	G-31
	Wiring harness disconnected or improperly connected (blinker switch and indicator lamp)	Repair or Replace	–
Turn Signal Light Does Not Flicker	Flasher unit defective	Replace	6-S22
	Blinker switch defective	Replace	6-S21

W10137180

LIGHTING SYSTEM (Continued)

Symptom	Probable Cause	Solution	Reference Page
Glow Lamp Does Not Light When Main Switch Is in Pre-heat Position	Battery discharged or defective	Recharge or Replace	G-17
	Slow blow fuse blown	Replace	G-30
	Wiring harness disconnected or improperly connected (between main switch 19 terminal and pre-heat indicator, between pre-heat indicator and glow plugs)	Repair or Replace	–
	Main switch defective	Replace	6-S9
	Glow lamp defective	Replace	–
Oil Pressure Lamp Lights Up When Engine Is Running	Engine oil pressure too low	Repair engine	–
	Engine oil insufficient	Replenish	G-13
	Oil pressure switch defective	Replace	6-S24
	Short circuit between oil pressure switch lead and chassis	Repair	–
Oil Pressure Lamp Does Not Light When Main Switch Is Turned ON and Engine Is Not Running	Bulb blown	Replace	–
	Oil pressure switch defective	Replace	6-S24
	Wiring harness disconnected or improperly connected (between panel board and oil pressure switch)	Repair or Replace	–

W10135800

GAUGES

Fuel Warning Lamp Does Not Light	Fuel gauge defective	Replace	–
	Fuel level sensor defective	Replace	6-S25
	Wiring harness disconnected or improperly connected (between fuel gauge and fuel level sensor)	Repair or Replace	–
Coolant Temperature Gauge Does Not Function	Coolant temperature gauge defective	Replace	–
	Coolant temperature sensor defective	Replace	6-S25
	Wiring harness disconnected or improperly connected (between coolant temperature gauge and coolant temperature sensor)	Repair or Replace	–

W10137180

2. SERVICING SPECIFICATIONS

Item		Factory Specification	Allowable Limit	
Battery	Voltage	More than 12 V	–	
	Potential Difference	Less than 0.1 V	–	
Glow Plug	Resistance	Approx. 0.9 Ω	–	
Alternator	Charging Current / Alternator Speed	14 to 15 A / 5200 min ⁻¹ (rpm)	–	
	Charging Voltage / Alternator Speed	14 to 15 A / 5200 min ⁻¹ (rpm)	–	
Head Light Switch	Switch OFF	Infinity	–	
	ON	0 Ω	–	
Blinker Switch	Switch OFF	Infinity	–	
	R	0 Ω	–	
	L	0 Ω	–	
Hazard Light Switch	Switch OFF	Infinity	–	
	ON	0 Ω	–	
Starter	Commutator	O.D.	30.0 mm 1.181 in.	29.0 mm 1.142 in.
		Difference of O.D.'s	Less than 0.02 mm 0.0008 in.	0.05 mm 0.0020 in.
	Mica	Undercut	0.50 to 0.80 mm 0.0197 to 0.0315 in.	0.20 mm 0.0079 in.
	Brush	Length	14.0 mm 0.551 in.	9.0 mm 0.354 in.
Alternator	Starter Resistance		Less than 1.0 Ω	–
	Rotor Resistance		2.9 Ω	–
	Slip Ring O.D.		1.44 mm 0.5669 in.	14.0 mm 0.5512
	Brush Length		10.0 mm 0.3937 in.	1.5 mm 0.0591

W10138740

3. TIGHTENING TORQUES

Tightening torques of screws, bolts and nuts on the table below are especially specified.
 (For general use screws, bolts and nuts : See page G-9.)

Item	N·m	kgf·m	lbf·ft
Starter B terminal nut	5.9 to 11.8	0.6 to 1.2	4.3 to 8.7

W10127360

4. CHECKING, DISASSEMBLING AND SERVICING

[1] CHECKING AND ADJUSTING



CAUTION

- To avoid accidental short circuit, be sure to attach the positive cable to the positive terminal before the negative cable is attached to the negative terminal.
- Never remove the battery cap while the engine is running.
- Keep electrolyte away from eyes, hands and clothes. If you are splattered with it, wash it away completely with water immediately.
- Keep open sparks and flames away from the battery at all times. Hydrogen gas mixed with oxygen becomes very explosive.

IMPORTANT

- If the machine is to be operated for a short time without battery (using a slave battery for starting), use additional current (lights) while engine is running and insulate terminal of battery. If this advice is disregarded, damage to alternator and regulator may result.

(1) Battery

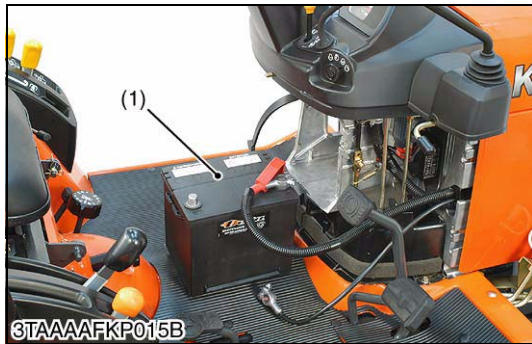

Battery Voltage

1. Stop the engine and turn the main switch **OFF**.
2. Connect the COM (-) lead of the voltmeter to the battery's negative terminal post and the (+) lead to the positive terminal post, and measure the battery voltage.
3. If the battery voltage is less than the factory specification, check the battery specific gravity and recharge the battery.

Battery voltage	Factory spec.	More than 12 V
-----------------	---------------	----------------

(1) Battery

W10125620

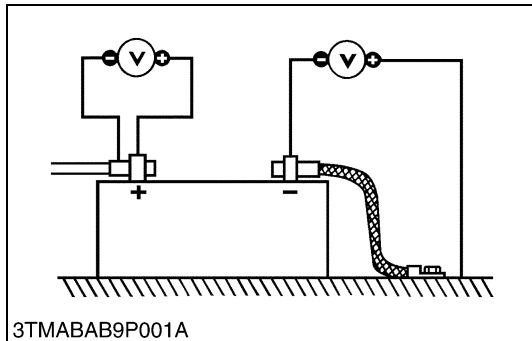

Battery Terminal Connection

1. Turn the main switch **ON**, and turn on the head light.
2. Measure the voltage with a voltmeter across the battery's positive terminal post and the cable terminal, and the voltage across the battery's negative terminal post and the chassis.
3. If the measurement exceeds the factory specification, clean the battery terminal posts and cable clamps, and tighten them firmly.

Potential difference	Factory spec.	Less than 0.1 V
----------------------	---------------	-----------------

W10126630

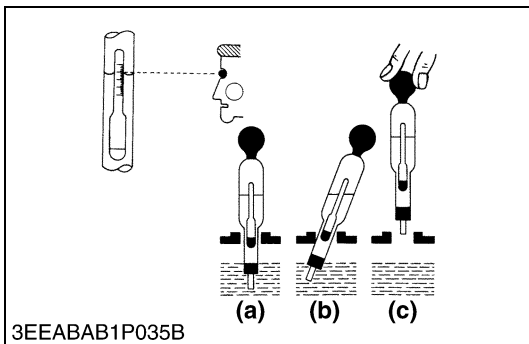
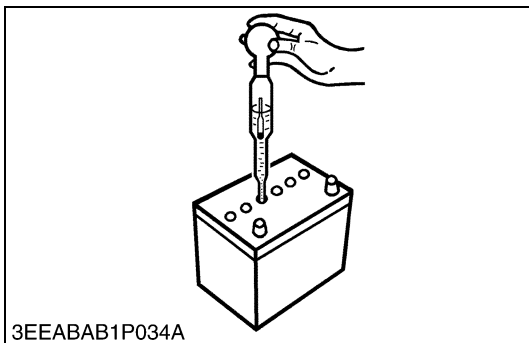

Battery Specific Gravity

1. Check the specific gravity of the electrolyte in each cell with a hydrometer.
2. When the electrolyte temperature differs from that at which the hydrometer was calibrated, correct the specific gravity reading following the formula mentioned in **(Reference)**.
3. If the specific gravity is less than 1.215 (after it is corrected for temperature), charge or replace the battery.
4. If the specific gravity differs between any two cells by more than 0.05, replace the battery.

■ **NOTE**

- **Hold the hydrometer tube vertical without removing it from the electrolyte.**
- **Do not suck too much electrolyte into the tube.**
- **Allow the float to move freely and hold the hydrometer at eye level.**
- **The hydrometer reading must be taken at the highest electrolyte level.**

(Reference)

- Specific gravity slightly varies with temperature. To be exact, the specific gravity decreases by 0.0007 with an increase of 1 °C (0.0004 with an increase of 1 °F) in temperature, and increases by 0.0007 with a decreases of 1 °C (0.0004 with a decrease of 1 °F).

Therefore, using 20 °C (68 °F) as a reference, the specific gravity reading must be corrected by the following formula :

- Specific gravity at 20 °C = Measured value + 0.0007 × (electrolyte temperature – 20 °C)
- Specific gravity at 68 °F = Measured value + 0.0004 × (electrolyte temperature – 68 °F)

Specific Gravity	State of Charge
1.260 Sp. Gr.	100 % Charged
1.230 Sp. Gr.	75 % Charged
1.200 Sp. Gr.	50 % Charged
1.170 Sp. Gr.	25 % Charged
1.140 Sp. Gr.	Very Little Useful Capacity
1.110 Sp. Gr.	Discharged

At an electrolyte temperature of 20 °C (68 °F)

(a) Good
(b) Bad

(c) Bad

W10127630

(2) Main Switch

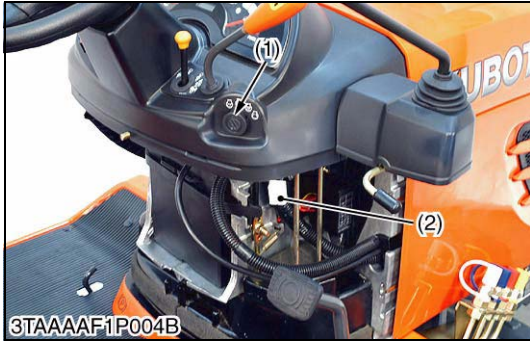

Main Switch Connector Voltage

1. Remove the under cover panel.
2. Disconnect the **4P** connector (4) and remove the main switch (1).
3. Measure the voltage with a voltmeter across the connector **30** (red) terminal and chassis.
4. If the voltage differs from the battery voltage (11 to 14 V), the wiring harness is faulty.

Voltage	Connector 30 terminal – chassis	Approx. battery voltage
---------	--	-------------------------

(1) Main Switch

(2) **4P** Connector

W10135530



Main Switch Continuity

1) Main Switch Key at OFF Position

1. Set the main switch **OFF** position.
2. Measure the resistance with an ohmmeter across the **B** terminal and the **ACC** terminal, **B** terminal and **ST** terminal, **B** terminal and **G** terminal.
3. If infinity is not indicated, the contacts of the main switch are faulty.

Resistance	B terminal – ACC terminal	Infinity
	B terminal – ST terminal	
	B terminal – G terminal	

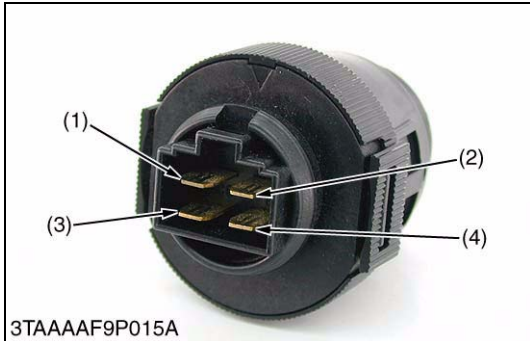

2) Main Switch Key at ON Position

1. Set the main switch **ON** position.
2. Measure the resistance with an ohmmeter across the **B** terminal and the **ACC** terminal.
3. If 0 ohm is not indicated, the **B – ACC** contact of the main switch are faulty.

Resistance	B terminal – ACC terminal	0 Ω
------------	---	-----

3) Main Switch Key at PREHEAT Position

1. Set and hold the main switch key at the **PREHEAT** position.
2. Measure the resistance with an ohmmeter across the **B** terminal and the **G** terminal, and measure the resistance across the **B** terminal and the **ACC** terminal.
3. If 0 ohm is not indicated, these contacts of the main switch are faulty.

Resistance	B terminal – G terminal	0 Ω
	B terminal – ACC terminal	

4) Main Switch Key at START Position

1. Set and hold the main switch key at the **START** position.
2. Measure the resistance with an ohmmeter across the **B** terminal and the **G** terminal, across the **B** terminal and the **ST** terminal, and across the **B** terminal and the **ACC** terminal.
3. If 0 ohm is not indicated, these contacts of the main switch are faulty.

Resistance	B terminal – G terminal	0 Ω
	B terminal – ST terminal	
	B terminal – ACC terminal	

(1) **B** Terminal
(2) **ST** Terminal

(3) **ACC** Terminal
(4) **G** Terminal

W10136580

(3) Starter

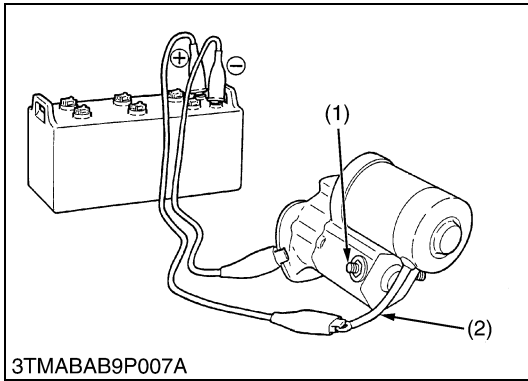

Motor Test



CAUTION

- **Secure the starter to prevent it from jumping up and down while testing the motor.**

1. Disconnect the battery negative cable from the battery.
2. Disconnect the battery positive cable and the leads from the starter.
3. Remove the starter from the engine.
4. Disconnect the connecting lead (2) from the starter C terminal (1).
5. Connect a jumper lead from the connecting lead (2) to the battery positive terminal post.
6. Connect a jumper lead momentarily between the starter motor housing and the battery negative terminal post.
7. If the motor does not run, check the motor.

(1) C Terminal

(2) Connecting Lead

W10142670

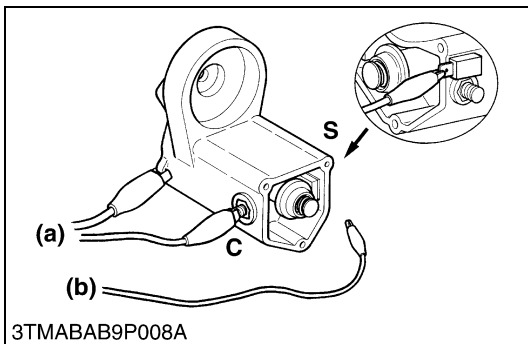

Magnet Switch Test (Pull-in, Holding Coils)

1. Remove the motor from the starter housing.
2. Prepare a 6 V battery for the test.
3. Connect jumper leads from the battery negative terminal to the housing and the starter C terminal.
4. The plunger should be attracted and the pinion gear should pop out when a jumper lead is connected from the battery positive terminal to the S terminal. It's a correct.
5. Disconnect the jumper lead to the starter C terminal. Then the pinion gear should remain popped out. It's a correct.

■ IMPORTANT

- **Testing time must be 3 to 5 sec..**

C : C Terminal

(a) To Negative Terminal

S : S Terminal

(b) To Positive Terminal

W1015210

(4) Glow Plug

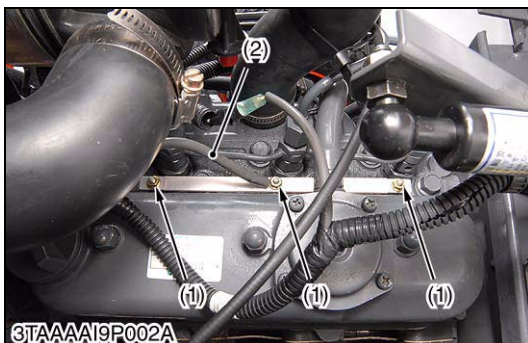

Lead Terminal Voltage

1. Disconnect the wiring lead (2) from the glow plug (1) after turning the main switch off.
2. Turn the main switch key to the "PREHEAT" position, and measure the voltage between the lead terminal and the chassis.
3. Turn the main switch key to the "START" position, and measure the voltage with a voltmeter between the lead terminal and the chassis.
4. If the voltage at either position differs from the battery voltage, the wiring harness or main switch is faulty.

Voltage (Lead terminal – Chassis)	Main switch key at "PREHEAT"	Approx. battery voltage
	Main switch key at "START"	Approx. battery voltage

(1) Glow Plug

(2) Wiring Lead (Positive)

W10149130

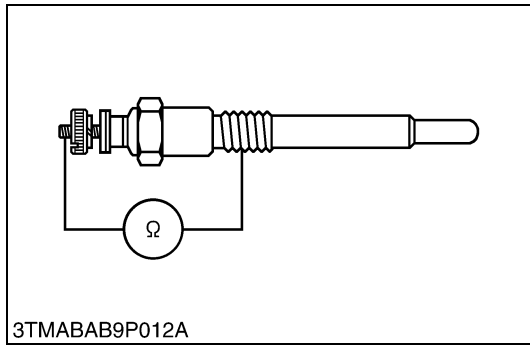

Glow Plug Continuity

1. Disconnect the lead from the glow plugs.
2. Measure the resistance with an ohmmeter between the glow plug terminal and the chassis.
3. If 0 ohm is indicated, the screw at the tip of the glow plug and the housing are short-circuited.
4. If the factory specification is not indicated, the glow plug is faulty.

Glow plug resistance	Factory spec.	Approx. 0.9 Ω
----------------------	---------------	---------------

W10151150

(5) Safety Switch



PTO Shift Lever Switch Continuity

1. Remove the left rear wheel.
2. Remove the PTO shift lever switch (1).
3. Measure the resistance with an ohmmeter across the switch terminals.
4. If the resistance values specified below are not indicated, the safety switch is faulty.

■ Plunger is pushed into the switch body

Resistance 1 terminal (5) - 2 terminal (6)	Factory spec.	0 Ω
Resistance 3 terminal (7) - 4 terminal (8)	Factory spec.	0 Ω

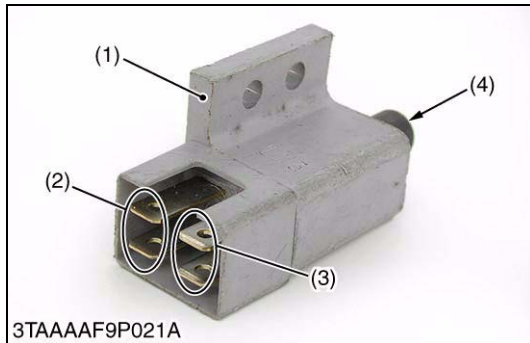

■ Plunger is released

Resistance 1 terminal (5) - 2 terminal (6)	Factory spec.	Infinity
Resistance 3 terminal (7) - 4 terminal (8)	Factory spec.	Infinity

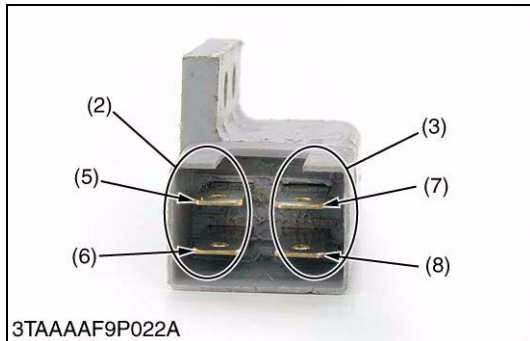

- | | |
|----------------------------|----------------|
| (1) PTO Shift Lever Switch | (5) 1 Terminal |
| (2) 2P Connector (LH) | (6) 2 Terminal |
| (3) 2P Connector (RH) | (7) 3 Terminal |
| (4) Plunger | (8) 4 Terminal |

W10158610

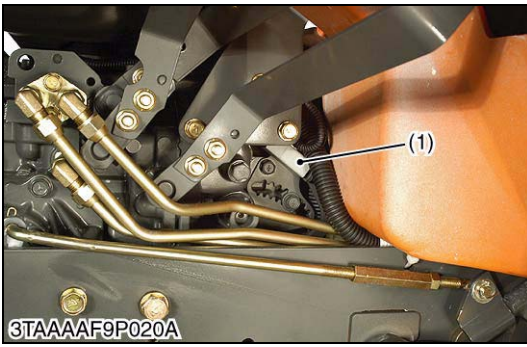

HST Neutral Switch Continuity

1. Remove the right rear wheel.
2. Remove the HST neutral switch (1).
3. Measure the resistance with an ohmmeter across the HST neutral switch terminals.
4. If the resistance values specified below are not indicated, the safety switch is faulty.

■ Plunger is pushed into the switch body

Resistance 1 terminal (5) - 2 terminal (6)	Factory spec.	0 Ω
Resistance 3 terminal (7) - 4 terminal (8)	Factory spec.	0 Ω

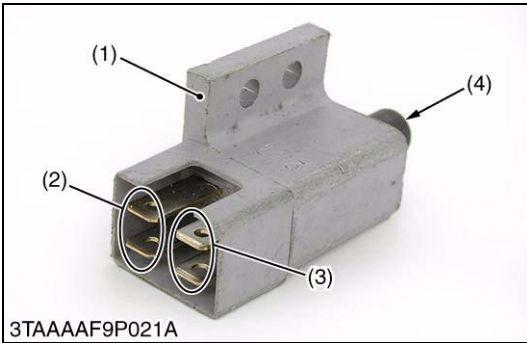

■ Plunger is released

Resistance 1 terminal (5) - 2 terminal (6)	Factory spec.	Infinity
Resistance 3 terminal (7) - 4 terminal (8)	Factory spec.	Infinity

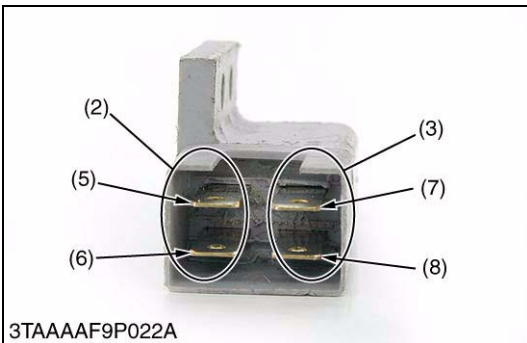

- | | |
|------------------------|----------------|
| (1) HST Neutral Switch | (5) 1 Terminal |
| (2) 2P Connector (LH) | (6) 2 Terminal |
| (3) 2P Connector (RH) | (7) 3 Terminal |
| (4) Plunger | (8) 4 Terminal |

W10384760

(6) Operator Presence Control (OPC) Switch

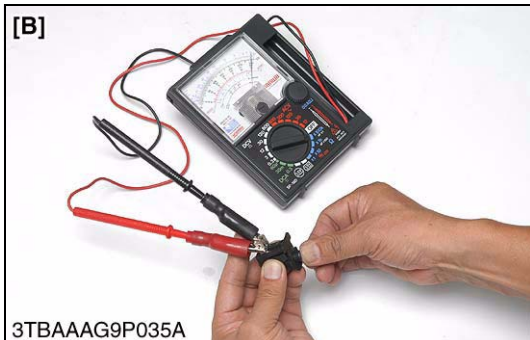
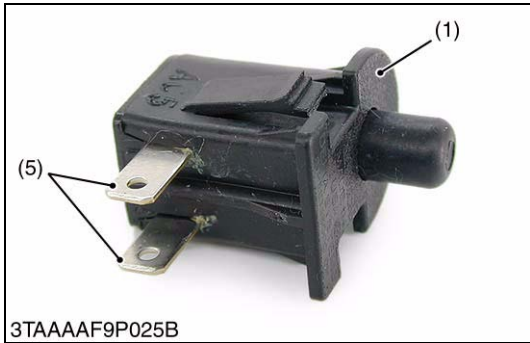

Seat Switch and Seat Turnover Switch Continuity Check

1. Disconnect the **2P** connectors (2) from the seat turnover switch (1) and the seat switch.

2. Remove the seat turnover switch (1).

3. Connect the circuit tester to the terminals (5).

(When switch is not pushed / When operator leave the seat)

1. Measure the resistance between terminals (5).

2. If continuity is not infinity, the switch is faulty. Replace it.

(When switch is pushed / When operator sits on the seat)

1. Measure the resistance between terminals (5).

2. If continuity is not 0 Ω, the switch is faulty. Replace it.

Resistance	When switch is not pushed / When operator leave the seat	Infinity
	When switch is pushed / When operator sits on the seat	0 Ω

- (1) Seat Turnover Switch
- (2) **2P** Connector
- (3) Seat Switch **2P** Connector
- (4) Seat
- (5) Terminals

[A] Seat Switch is not Pushed
[B] Seat Switch is Pushed

W10440960

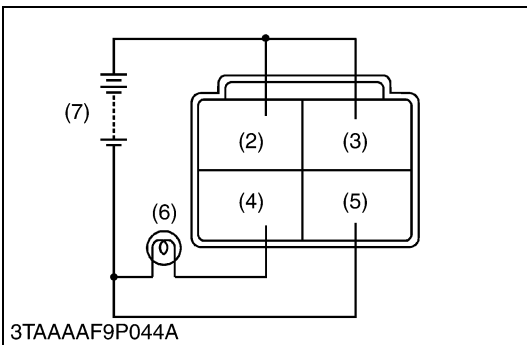
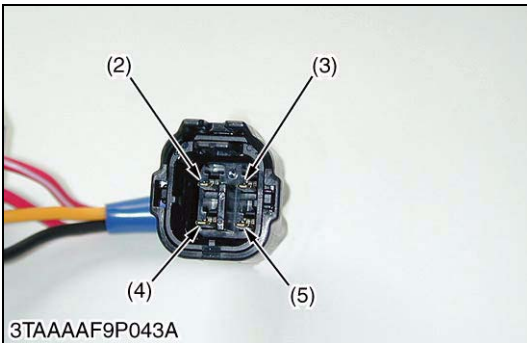
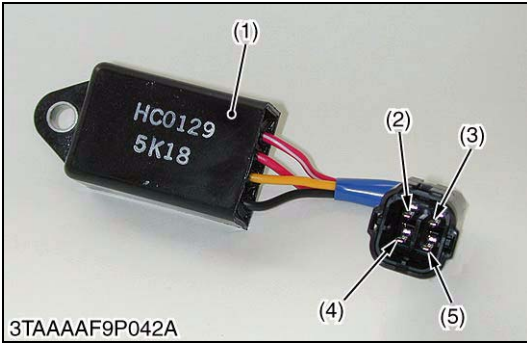

Checking OPC Timer

1. Remove the OPC timer. (The OPC timer is located under the fender center stay.)
2. Connect the jumper leads across the battery terminal and the Red / White terminal (2), and across the battery positive terminal and the Yellow terminal (3).
3. Connect the jumper lead across the battery negative terminal and the Black terminal (5), and across the battery negative terminal and the Blue terminal.
4. Connect the jumper lead across the Red terminal (4) and the bulb terminal.
5. The bulb lights up when disconnecting the jumper lead from the Red / White terminal (2) 0.7 to 1.3 seconds, the OPC timer (1) is proper.

- | | |
|---|-------------------------------------|
| (1) OPC Timer | (5) Black Terminal (To Frame Earth) |
| (2) Red / White Terminal (From Battery) | (6) Bulb (Load) |
| (3) Yellow Terminal (From OPC Switch) | (7) Battery |
| (4) Red Terminal (To Key Stop Solenoid) | |

W10647550

(7) Fuel Pump

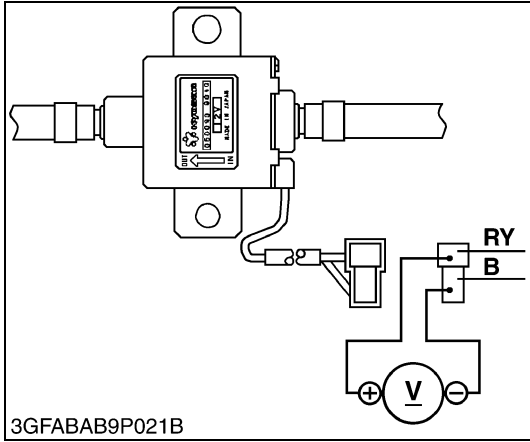

Connector Voltage

1. Disconnect the **2P** connector from the fuel pump.
2. Turn the main switch key to the “ON” position, and measure the voltage with a voltmeter between the connector terminals.
3. If the voltage differs from the battery voltage, the wiring harness or main switch is faulty.

Voltage	Between connector terminals	Approx. battery voltage
---------	-----------------------------	-------------------------

W1016341

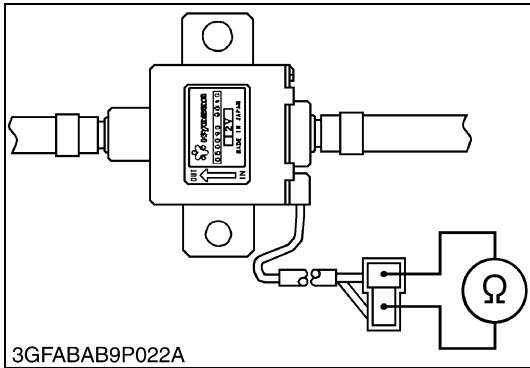

Fuel Pump Continuity

1. Disconnect the **2P** connector from the fuel pump.
2. Check the continuity between the connector terminals with an ohmmeter.
3. If it does not conduct, the fuel pump is faulty.

W1016134

(8) Engine Stop Solenoid

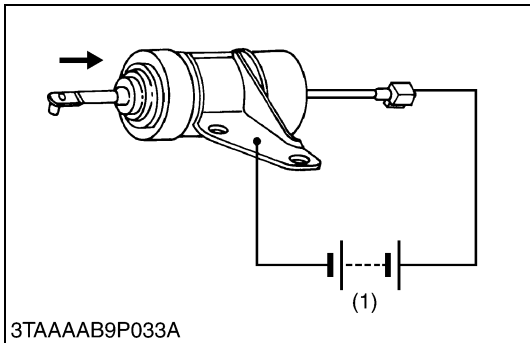

Engine Stop Solenoid Test

1. Disconnect the **1P** connector from the engine stop solenoid.
2. Remove the engine stop solenoid from the engine.
3. Connect the jumper leads from the battery positive terminal to the **1P** connector, and from the battery negative terminal to the engine stop solenoid body.
4. If the solenoid plunger is not attracted, the engine stop solenoid is faulty.

(1) Battery (12 V)

W1019658

(9) Timer Relay

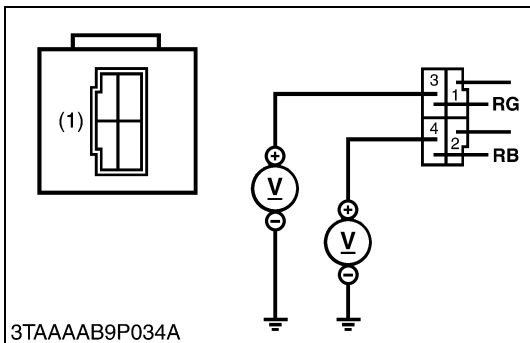

Timer Relay Connector Voltage

1. Disconnect the connector from the timer relay after turning the main switch off.
2. Measure the voltage with a voltmeter across the connector terminal **4** and chassis.
3. Turn the main switch on, and measure the voltage across the connector terminal **3** and chassis.
4. If these voltages differ from the battery voltage, the wiring harness or main switch is faulty.

Voltage	Connector terminal 4 -chassis	Approx. battery voltage
		Connector terminal 3 -chassis

(1) Timer Relay

W1016544

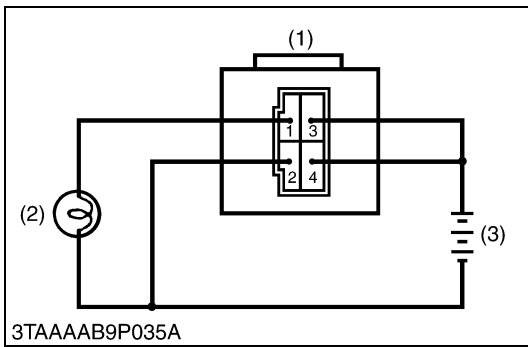

Test of Timer Relay

1. Remove the timer relay from the tractor.
2. Connect jumper leads across the battery positive terminal and the timer relay terminal 3, and across the battery positive terminal and the timer relay terminal 4.
3. Connect jumper leads across the battery negative terminal and the timer relay terminal 2, and across the battery negative terminal and the bulb terminal.
4. Connect jumper lead across the timer relay terminal 1 and the bulb terminal.
5. The bulb lights up when disconnecting a jumper lead from the terminal 3 and goes off 6 to 13 seconds later, the timer relay is proper.

- (1) Timer Relay (3) Battery (12V)
 (2) Load (Lamp)

W1016721

(10) Charging System

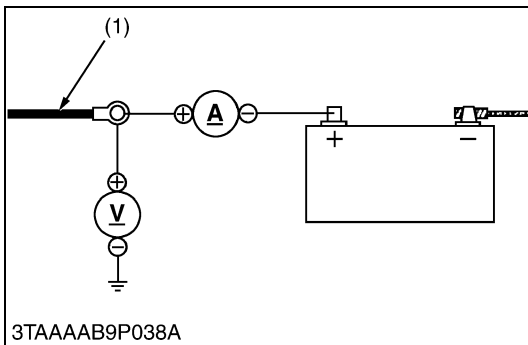

Battery Charging Current

1. After starting the engine, disconnect the battery positive cord (+), and connect an ammeter and voltmeter. Then switch on all electrical loads (such as head lights) and measure the charging current.

NOTE

- Connect an ammeter only after starting the engine.
- When the electrical loads is considerably low or the battery is fully charged, the specified reading may not be obtained.

Factory spec.	Current	14 to 15 A
	Voltage	14 to 15 V
	Alternator speed	5200 min ⁻¹ (rpm)

- (1) Battery Positive Cord

W1048417

(11) Alternator

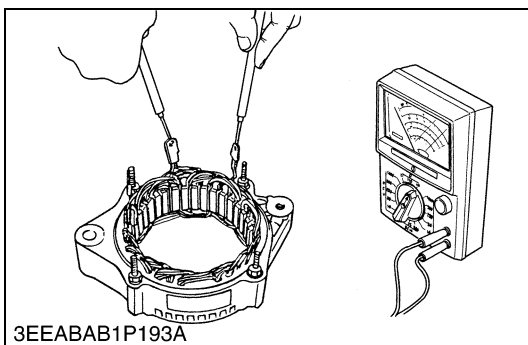

Stator

1. Measure the resistance across each lead of the stator coil with resistance range of circuit tester.
2. If the measurement is not within factory specification, replace it.
3. Check the continuity across each stator coil lead and core with resistance range of circuit tester.
4. If infinity is not indicated, replace it.

Resistance	Factory spec.	Less than 1.0 Ω
------------	---------------	-----------------

W1019964

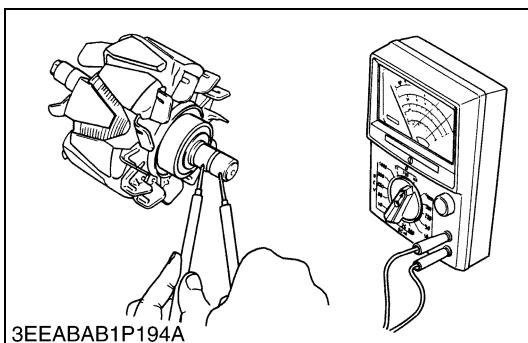

Rotor

1. Measure the resistance across the slip rings.
2. If the resistance is not the factory specification, replace it.
3. Check the continuity across the slip ring and core with resistance range of circuit tester.
4. If infinity is not indicated, replace it.

Resistance	Factory spec.	2.9 Ω
------------	---------------	-------

W1020094

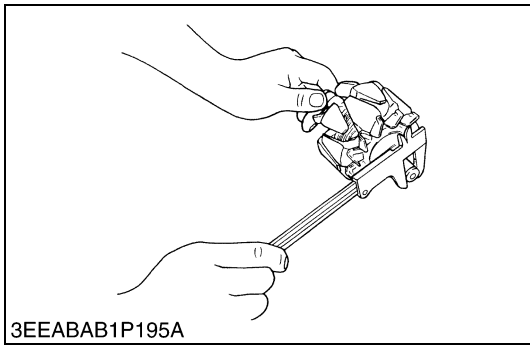

Slip Ring

1. Check the slip ring for score.
2. If scored, correct with an emery paper or on a lathe.
3. Measure the O.D. of slip ring with vernier calipers.
4. If the measurement is less than the allowable limit, replace it.

Slip ring O.D.	Factory spec.	14.4 mm 0.567 in.
	Allowable limit	14.0 mm 0.551 in.

W12365478

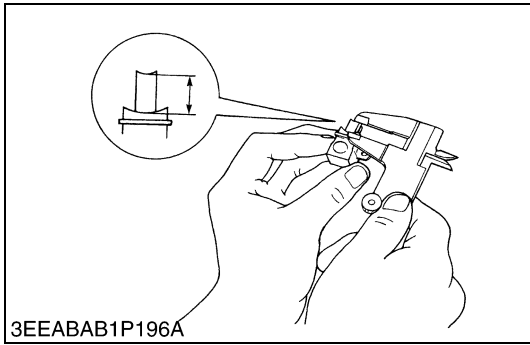

Brush Wear

1. Measure the brush length with vernier calipers.
2. If the measurement is less than allowable limit, replace it.
3. Make sure that the brush moves smoothly.
4. If the brush is defective, replace it.

Brush length	Factory spec.	10.5 mm 0.413 in.
	Allowable limit	8.4 mm 0.331 in.

W1020329

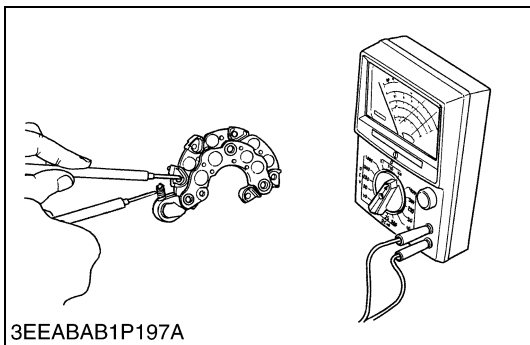

Rectifier

1. Check the continuity across each diode of rectifier with resistance range of circuit tester.
2. The rectifier is normal if the diode in the rectifier conducts in one direction and does not conduct in the reverse direction.

W1020452

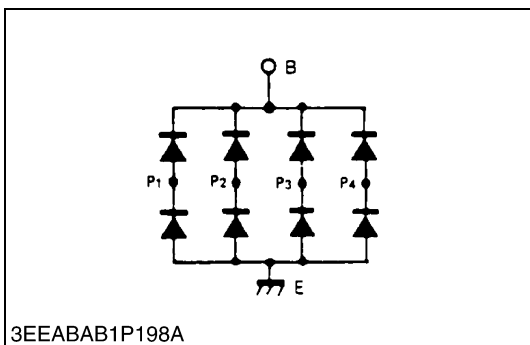

(12) Combination Switch

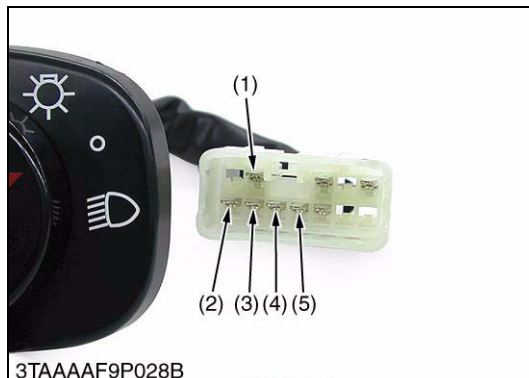
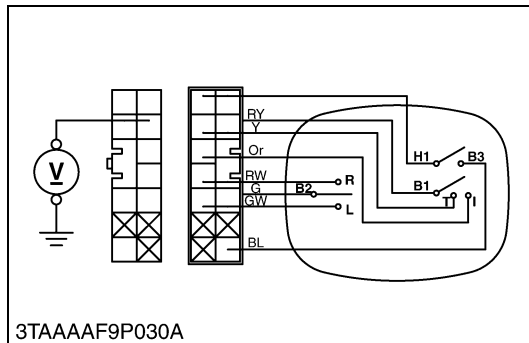
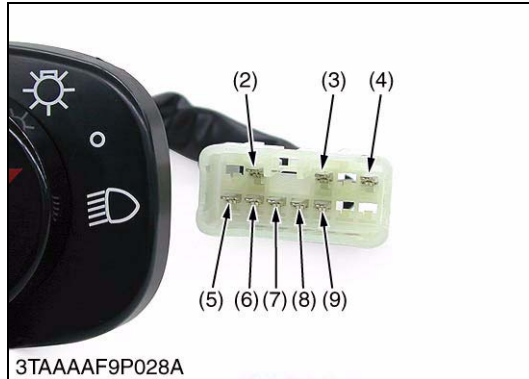

Combination Switch

1. Remove the meter panel, and disconnect the combination switch connector.
2. Remove the combination switch (1) and perform the following checks **1) to 8)**.

- | | |
|------------------------|------------------------|
| (1) Combination Switch | (6) Yellow Lead |
| (2) Red / Yellow Lead | (7) Orange Lead |
| (3) Green Lead | (8) Red / White Lead |
| (4) Black / Blue Lead | (9) Green / White Lead |
| (5) Blue / White Lead | |

W1049462

1) Connector Voltage

1. Connect the combination switch connector to the main wire harness.
2. Measure the voltage with a voltmeter across the connector **B1** terminal and chassis when the main switch is **ON** position.
3. If the voltage differs from the battery voltage, the wiring harness and main switch is faulty.

Voltage	Main switch at "ON" position	B1 terminal - Chassis	Battery voltage
---------	------------------------------	-----------------------	-----------------

W1050272

2) Head Light Switch Continuity when Setting Switch at "OFF" Position

1. Set the light switch to the **OFF** position.
2. Measure the resistance with an ohmmeter across the red / yellow lead (1) to the orange lead (4), the red / yellow lead (1) to the yellow lead (3).
3. If infinity is not indicated, the head light switch is faulty.

Resistance (Switch at OFF position)	Red / Yellow lead (1) - Orange lead (4)	Infinity
	Red / Yellow lead (1) - Yellow lead (3)	

- (1) Red / Yellow Lead
- (2) Blue / White Lead
- (3) Yellow Lead
- (4) Orange Lead
- (5) Red / White Lead

A : Head Light "OFF" Position

W1050981

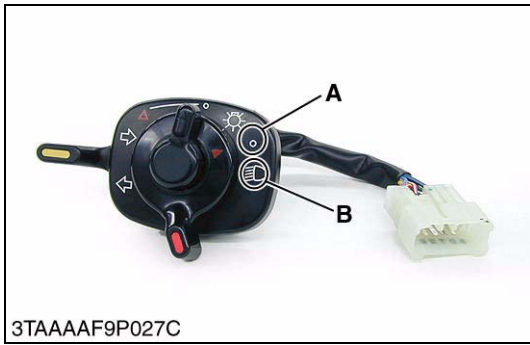

3) Head Light Switch Continuity when Setting Switch at “ON” Position

1. Set the light switch to the **ON** position.
2. Measure the resistance with an ohmmeter across the red / yellow lead (1) to the orange lead (4) and the red / yellow lead (1) to the yellow lead (3).
3. If infinity is not indicated, the head light switch is faulty.

Resistance (Switch at ON position)	Red / Yellow lead (1) - Orange lead (4)	0 Ω
	Red / Yellow lead (1) - Yellow lead (3)	

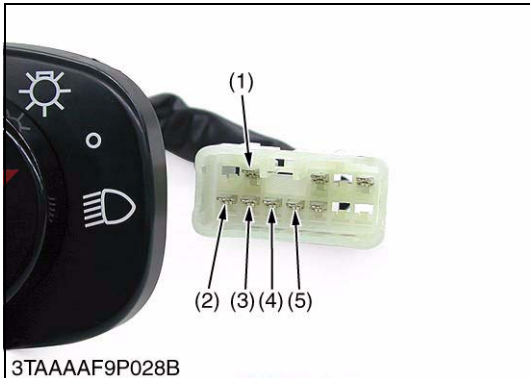

- (1) Red / Yellow Lead
- (2) Blue / White Lead
- (3) Yellow Lead
- (4) Orange Lead
- (5) Red / White Lead

A : Head Light “OFF” Position

W1051881



4) Turn Signal Light Switch Continuity when Setting Switch Knob “OFF” Position

1. Set the turn signal switch knob to the **OFF** position.
2. Measure the resistance with an ohmmeter across the green lead (1) and red / white lead (2), and across to the green lead (1) and green / white lead (3).
3. If infinity is not indicated, the combination switch is faulty.

Resistance (Switch knob at OFF position)	Green lead (1) - Red / White lead (4)	0 Ω
	Green lead (1) - Green / White lead (3)	

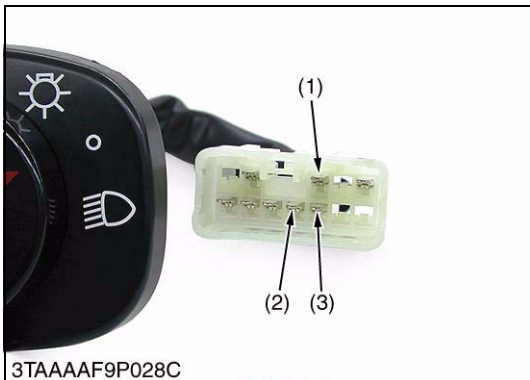

- (1) Green Lead
- (2) Red / White Lead
- (3) Green / White Lead

A : Turn Signal Light Switch “OFF” Position

W1052305



5) Turn Signal Light Switch Continuity when Setting Switch Knob "RIGHT" Position

1. Set the turn signal switch knob to the **RIGHT** position.
2. Measure the resistance with an ohmmeter across the green lead (1) and red / white lead (2), and across to the green lead (1) and green / white lead (3).
3. If 0 Ω is not indicated, the combination switch is faulty.

Resistance (Switch knob at RIGHT position)	Green lead (1) - Red / White lead (4)	0 Ω
	Green lead (1) - Green / White lead (3)	Infinity

- (1) Green Lead
- (2) Red / White Lead
- (3) Green / White Lead

A : Turn Signal Light Switch "RIGHT" Position

W1052995

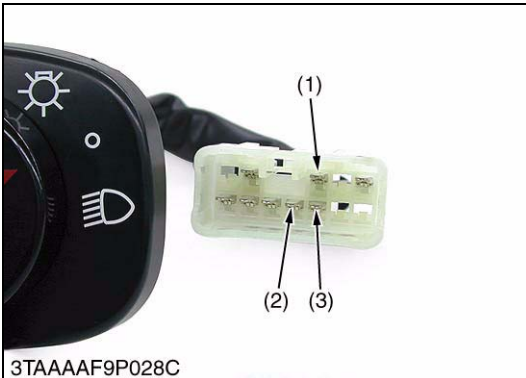

6) Turn Signal Light Switch Continuity when Setting Switch Knob "LEFT" Position

1. Set the turn signal switch knob to the **LEFT** position.
2. Measure the resistance with an ohmmeter across the green lead (1) and red / white lead (2), and across to the green lead (1) and green / white lead (3).
3. If 0 Ω is not indicated, the combination switch is faulty.

Resistance (Switch knob at LEFT position)	Green lead (1) - Red / White lead (4)	Infinity
	Green lead (1) - Green / White lead (3)	0 Ω

- (1) Green Lead
- (2) Red / White Lead
- (3) Green / White Lead

A : Turn Signal Light Switch "LEFT" Position

W1053450

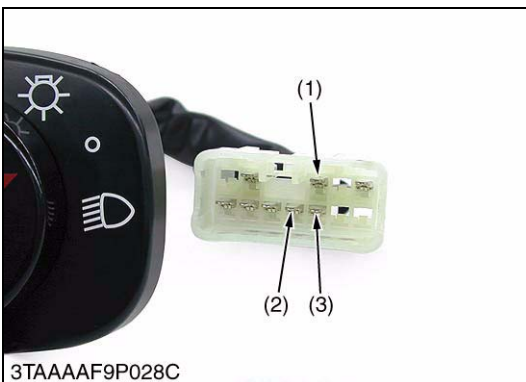



7) Hazard Switch Continuity when Setting Switch Knob at "OFF" Position

1. Set the hazard switch knob to the **OFF** position.
2. Measure the resistance with an ohmmeter across the black / blue lead (1) and blue / white lead (2).
3. If infinity is not indicated, the combination switch is faulty.

Resistance (Hazard switch at OFF position)	Black / Blue lead (1) - Blue / White lead (2)	Infinity
---	--	----------

- (1) Black / Blue Lead
(2) Blue / White Lead

A : Hazard Switch "OFF" Position

W1053841

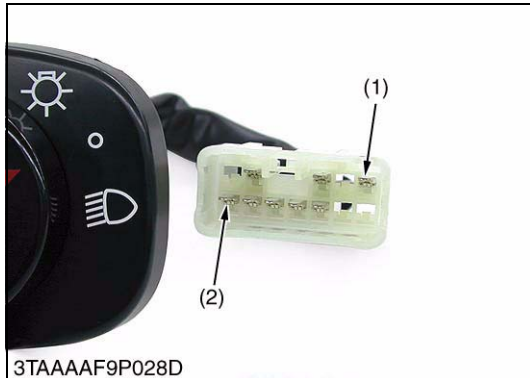

8) Hazard Switch Knob at "ON" Position

1. Set the hazard switch knob to the **ON** position.
2. Measure the resistance with an ohmmeter across the black / blue lead (1) and blue / white lead (2).
3. If 0 Ω is not indicated, the combination switch is faulty.

Resistance (Hazard switch at ON position)	Black / Blue lead (1) - Blue / White lead (2)	0 Ω
--	--	-----

- (1) Black / Blue Lead
(2) Blue / White Lead

A : Hazard Switch "ON" Position

W1054637

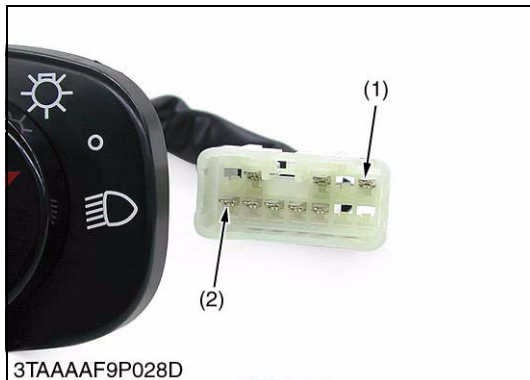



Flasher Unit

1. Remove the under panel.
2. Disconnect the coupler (2) from flasher unit.
3. Measure the voltage with a voltmeter across the terminal **h** and terminal **c** or chassis.
4. If the voltage differs from the battery voltage, the wiring harness is faulty.

Voltage	Terminal h – Terminal c or Chassis	Approx. battery voltage
---------	--	-------------------------

(1) Flasher Unit

(2) Coupler

W1055033

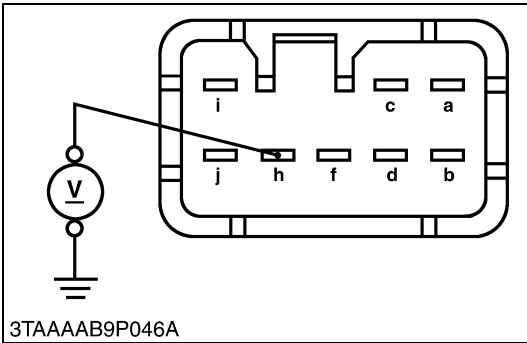

Flasher Unit Actuation Test

1. Set the hazard switch to the **ON** position, and make sure the hazard light gives 60 to 85 flashes for a minute.
2. With the main switch and the hazard switch at the **ACC** and **ON** positions, respectively, move the turn signal light switch to the left. Make sure that the right-hand light stays on and the left-hand light gives flashes earlier (by about 20 flashes) than when the hazard lamp is activated. Then move the turn signal light switch to the right and make sure the corresponding actions take place.
3. Now set the main switch to the **ACC** position and move the blinker switch alone. Make sure the same actions as above result.
4. If both the hazard switch and the turn signal light switch function but the above actions do not take place, replace the flasher unit with new one.

(1) Hazard Light Switch

(3) Flasher Unit

(2) Turn Signal Light Switch

W36974125

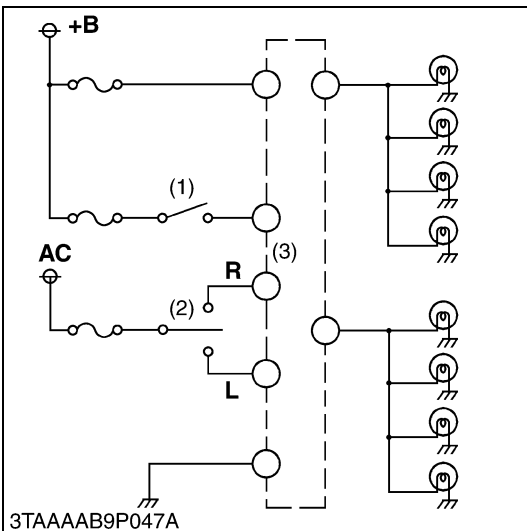

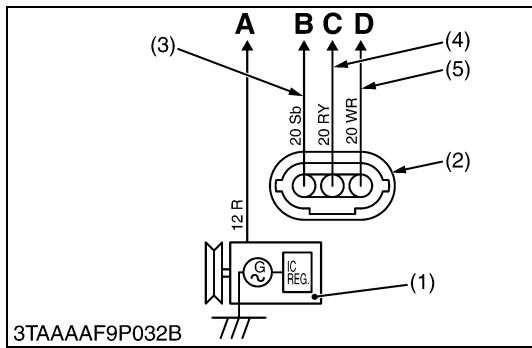
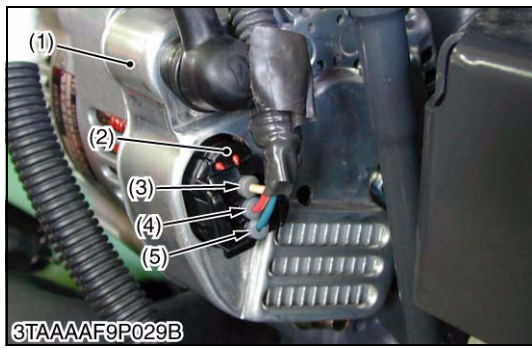

Charge Lamp (Charging Circuit)

1. Disconnect the **3P** connector from the alternator after turning the main switch **OFF**.
2. Turn the main switch **ON** and connect a jumper lead from the wiring harness connector terminal (White / Red) to the chassis.

■ **NOTE**

- If you connect the jumper lead from the wiring harness connector terminal (White / Red) to the chassis, **15A fuse will be blown. Do not connect the lead to Red / Yellow terminal.**
3. If the charge lamp does not light, the wiring harness or fuse is faulty.

- (1) Alternator
- (2) **3P** Connector
- (3) **Sb** (Sky Blue) Terminal
- (4) **RY** (Red / Yellow) Terminal
- (5) **WR** (White / Red) Terminal

- A** : To Main Switch
- B** : To Hour Meter and Tachometer
- C** : To Charge Lamp
- D** : To Ground

W123698547

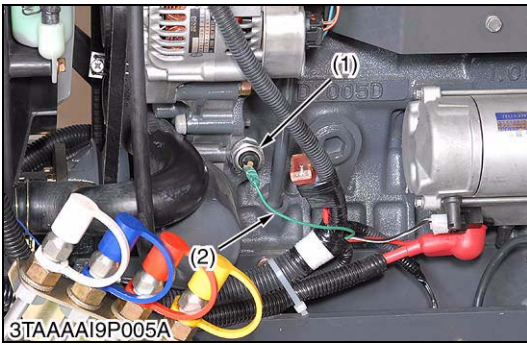

Engine Oil Pressure Lamp

1. Disconnect the lead (2) from the engine oil pressure switch (1) after turning the main switch **OFF**.
2. Turn the main switch **ON** and connect a jumper lead from the lead to the chassis.
3. If the engine oil pressure indicator lamp does not light, the wiring harness is faulty.

(1) Engine Oil Pressure Switch
(2) Lead

(a) From Oil Pressure Lamp

W78965432

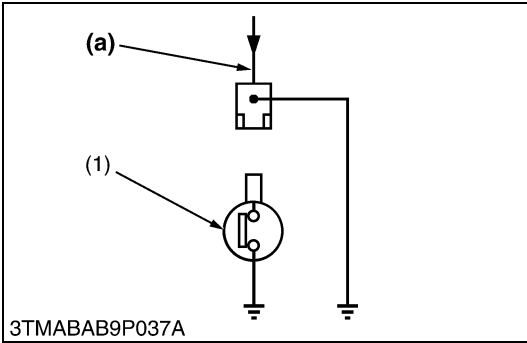

Engine Oil Pressure Switch Continuity

1. Disconnect the lead (2) from the engine oil pressure switch (1).
2. Measure the resistance with an ohmmeter across the switch terminal and the chassis.
3. If 0 ohm is not indicated in the normal state, the switch is faulty.
4. If infinity is not indicated at pressure over 4.9 kPa (0.5 kgf/cm², 7 psi), the switch is faulty.

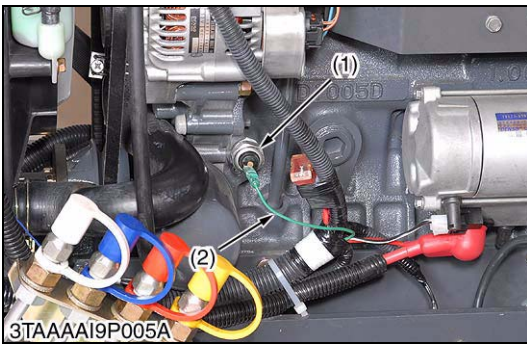

Resistance (Switch terminal – Chassis)	In normal state	0 Ω
	At pressure over approx. 4.9 kPa (0.5 kgf/cm ² , 7 psi)	Infinity

(1) Engine Oil Pressure Switch

(2) Lead

W1055934

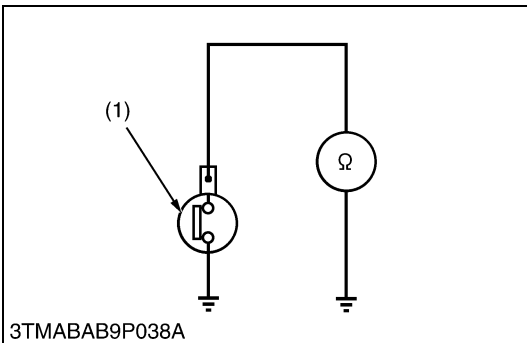

(13) Gauge

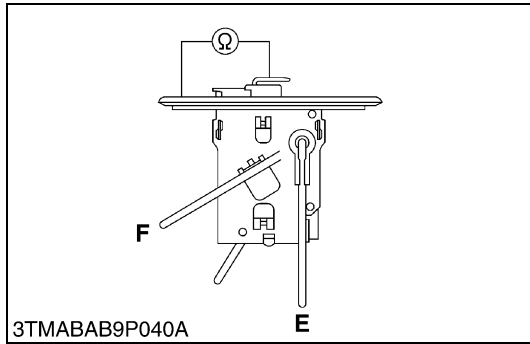

Fuel Level Sensor

1) Sensor Continuity

1. Remove the fuel level sensor from the fuel tank.
2. Measure the resistance with an ohmmeter across the sensor terminal and its body.
3. If the reference values are not indicated, the sensor is faulty.

Resistance (Sensor terminal – its body)	Reference value	Float at upper-most position	1 to 5 Ω
		Float at lower-most position	103 to 117 Ω

E : Empty

F : Full

W56478923

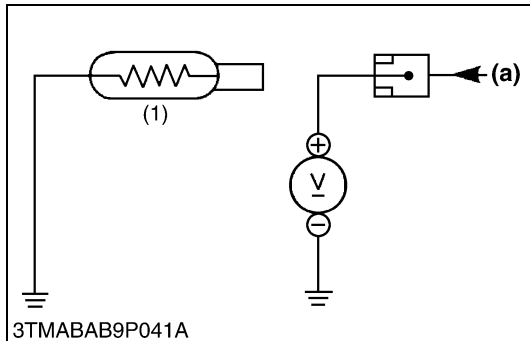

Coolant Temperature Sensor (Thermo Unit)

1) Lead Terminal Voltage

1. Disconnect the lead from the coolant temperature sensor after turning the main switch **OFF**.
2. Turn the main switch **ON** and measure the voltage with a voltmeter across the lead terminal and the chassis.
If the voltage differs from the battery voltage, the wiring harness, fuse or coolant temperature gauge is faulty.

Voltage	Lead terminal – Chassis	Approx. battery voltage
---------	-------------------------	-------------------------

2) Sensor Continuity

1. Measure the resistances with an ohmmeter across the sensor terminal and the chassis.
2. If the reference value is not indicated, the sensor is faulty.

Resistance (Sensor terminal – Chassis)	Reference value	Approx. 16.1 Ω at 120 °C (248 °F)
		Approx. 27.4 Ω at 100 °C (212 °F)
		Approx. 51.9 Ω at 80 °C (176 °F)
		Approx. 153.9 Ω at 50 °C (122 °F)

(1) Coolant Temperature Sensor

(a) From Temperature Gauge

W56874921

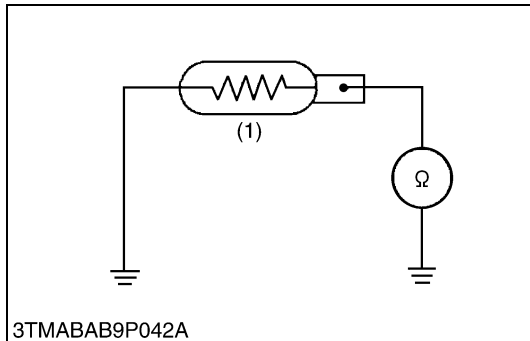

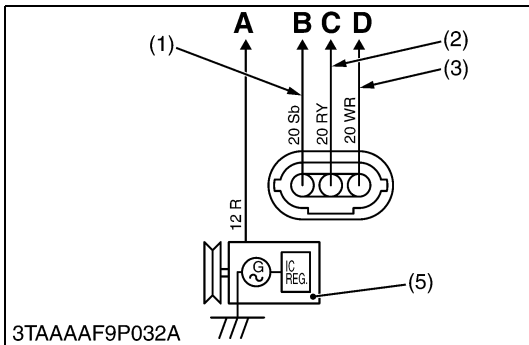
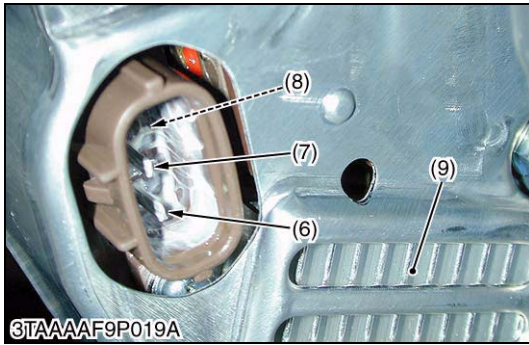
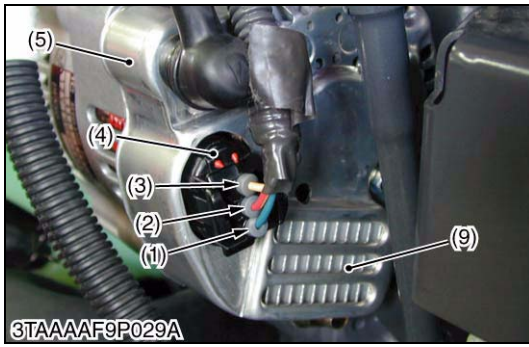

Hour Meter and Tachometer

1. Disconnect the **3P** connector (4) from the IC regulator (9) located in the alternator (5) after starting the engine.
2. Measure the voltage with a voltmeter across the hour meter terminal (6) and the alternator body when the hour meter or tachometer does not indicated the proper value.
3. If the measured voltages differ from the specified voltage, the hour meter and tachometer is faulty.

Voltage while engine runs at idling speeds	Hour meter terminal – Alternator body	Approx. battery voltage
--	---------------------------------------	-------------------------

- (1) Sb (Sky Blue) Lead
 - (2) RY (Red / Yellow) Lead
 - (3) WR (White / Red) Lead
 - (4) **3P** Connector
 - (5) Alternator
 - (6) Hour Meter and Tachometer Terminal
 - (7) Ground Terminal
 - (8) Charge Lamp Terminal
 - (9) IC Regulator
- A : To Main Switch**
 - B : To Hour Meter and Tachometer**
 - C : To Ground**
 - D : To Charge Lamp**

W1057349

(14) DC Outlet

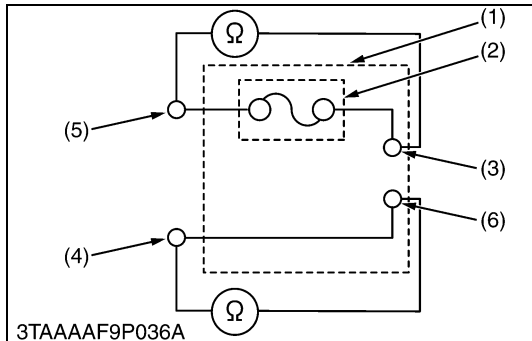
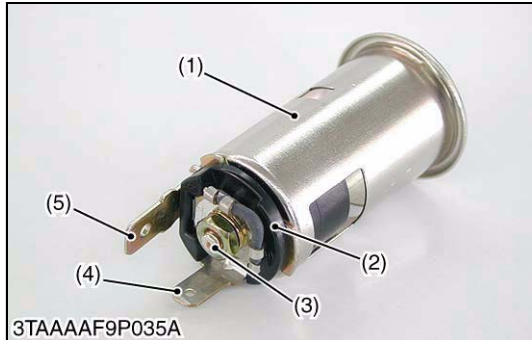

DC Outlet Connector Voltage and DC Outlet Continuity

1. Disconnect the connector from the DC outlet. And turn the main switch "ON".
2. Measure the voltage with a voltmeter across the connector red / blue lead and the chassis.
If the voltage differs from the battery voltage the wiring harness is faulty.
3. Disconnect the connector from the DC outlet. Since the DC outlet can not be removed easily, measure the continuity with a ohm meter across the plus terminal (4) and the nut (3), and across the earth terminal (5) and the DC outlet case (6).
4. If the resistance differs from 0 ohm, the DC outlet body (1) is faulty.

DC outlet connector voltage	Red / Blue lead – Chassis	Battery voltage
DC outlet continuity	Plus terminal – Nut	0 Ω
	Earth terminal – DC outlet case	

- (1) DC Outlet Body
- (2) Fuse
- (3) Nut
- (4) Plus Terminal (for Battery)
- (5) Earth Terminal (for Chassis)
- (6) DC Outlet Case

W1063447

[2] DISASSEMBLING AND ASSEMBLING

(1) Starter

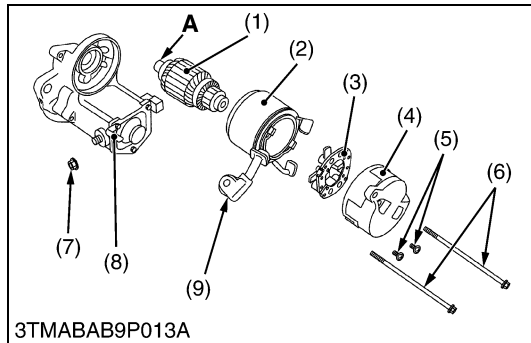

Motor

1. Disconnect the connecting lead (9) from the magnet switch (8).
2. Remove the screws (6), and then separate the end frame (4), yoke (2) and armature (1).
3. Remove the two screws (5), and then take out the brush holder (3) from the end frame (4).

(When reassembling)

- Apply grease to the spline teeth (A) of the armature (1).

Tightening torque	Nut (7)	5.9 to 11.8 N·m 0.6 to 1.2 kgf·m 4.3 to 8.7 lbf·ft
-------------------	---------	--

- | | |
|------------------|-------------------------|
| (1) Armature | (7) Nut |
| (2) Yoke | (8) Magnet Switch |
| (3) Brush Holder | (9) Connecting Lead |
| (4) End Frame | |
| (5) Screw | A : Spline Teeth |
| (6) Screw | |

W1016288

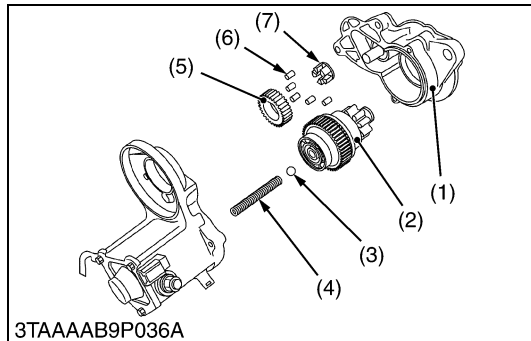

Magnet Switch

1. Remove the drive end frame (1) mounting screws.
2. Take out the overrunning clutch (2), ball (3), spring (4), gears (5), rollers (6) and retainer (7).

(When reassembling)

- Apply grease to the gear teeth of the gears (5) and overrunning clutch (2), and ball (3).

- | | |
|------------------------|--------------|
| (1) Drive End Frame | (5) Gear |
| (2) Overrunning Clutch | (6) Roller |
| (3) Ball | (7) Retainer |
| (4) Spring | |

W1016728

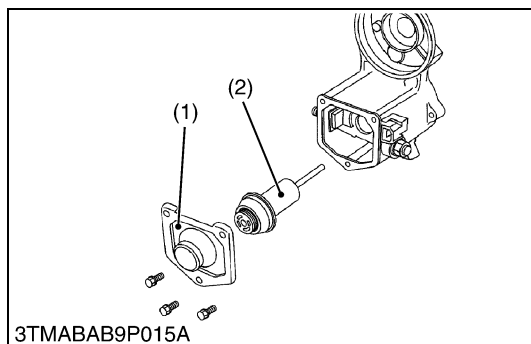

Plunger

1. Remove the end cover (1).
2. Take out the plunger (2).

- | | |
|---------------|-------------|
| (1) End Cover | (2) Plunger |
|---------------|-------------|

W1016883

(2) Alternator



Alternator

1. Check the battery charging voltage while engine runs.
2. Check the increasing voltage when increasing the engine revolution.
3. If the battery charging voltage does not increase, the alternator is faulty.
4. Replace the alternator as an assembly.

- | |
|-------------|
| (1) Battery |
|-------------|

W1058597

[3] SERVICING

(1) Starter

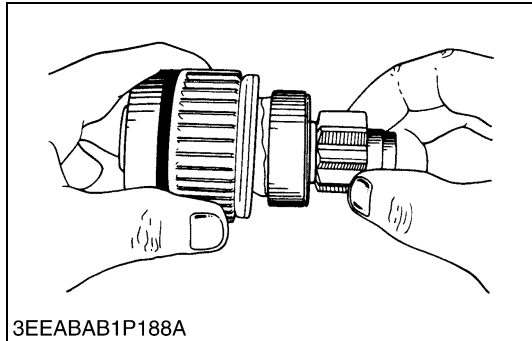

3EEABAB1P188A

Overrunning Clutch

1. Inspect the pinion for wear or damage.
2. If there is any defect, replace the overrunning clutch assembly.
3. Check that the pinion turns freely and smoothly in the overrunning direction and does not slip in the cranking direction.
4. If the pinion slips or does not rotate in the both directions, replace the overrunning clutch assembly.

W1016990

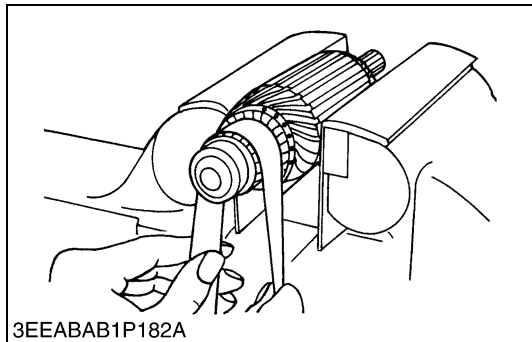

3EEABAB1P182A

Commutator and Mica

1. Check the contact face of the commutator for wear, and grind the commutator with emery paper if it is slightly worn.
2. Measure the commutator O.D. with an outside micrometer at several points.
3. If the minimum O.D. is less than the allowable limit, replace the armature.
4. If the difference of the O.D.'s exceeds the allowable limit, correct the commutator on a lathe to the factory specification.
5. Measure the mica undercut.
6. If the undercut is less than the allowable limit, correct it with a saw blade and chamfer the segment edges.

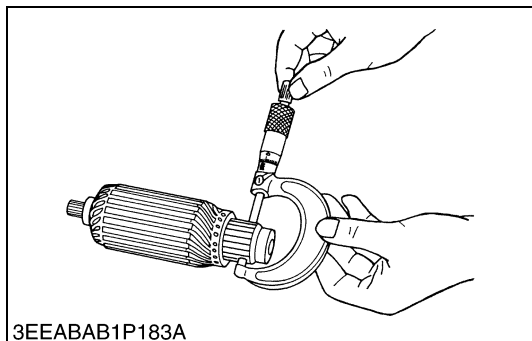

3EEABAB1P183A

Commutator O.D.	Factory spec.	30.0 mm 1.181 in.
	Allowable limit	29.0 mm 1.142 in.

Difference of O.D.'s	Factory spec.	Less than 0.02 mm 0.0008 in.
	Allowable limit	0.05 mm 0.0020 in.

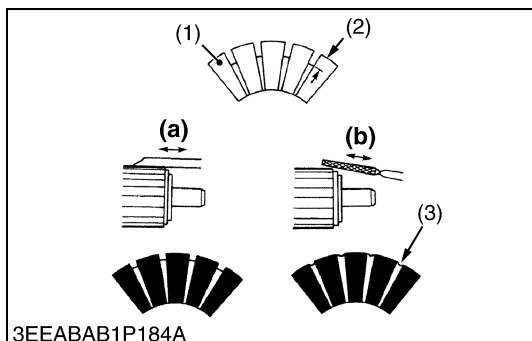

3EEABAB1P184A

Mica undercut	Factory spec.	0.50 to 0.80 mm 0.0197 to 0.0315 in.
	Allowable limit	0.20 mm 0.0079 in.

- (1) Segment
(2) Undercut
(3) Mica

(a) Correct
(b) Incorrect

W1017092

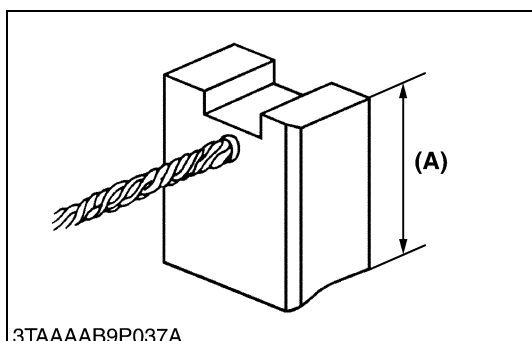

3TAAAB9P037A

Brush Wear

1. If the contact face of the brush is dirty or dusty, clean it with emery paper.
2. Measure the brush length (A) with vernier calipers.
3. If the length is less than the allowable limit, replace the yoke assembly and brush holder.

Brush length (A)	Factory spec.	14.0 mm 0.551 in.
	Allowable limit	9.0 mm 0.354 in.

W1017544

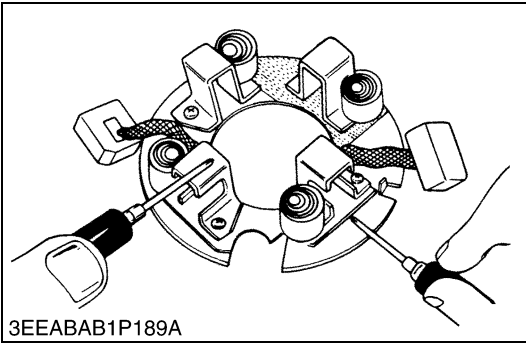

Brush Holder

1. Check the continuity across the brush holder and the holder support with an ohmmeter.
2. If it conducts, replace the brush holder.

W1017672

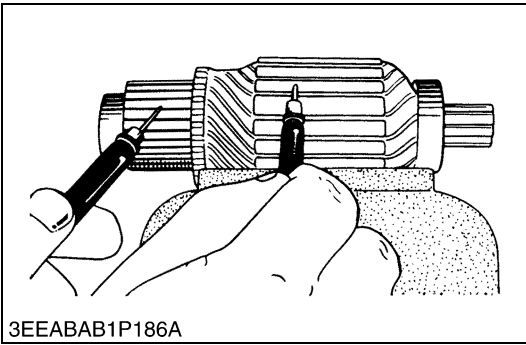

Armature Coil

1. Check the continuity across the commutator and armature coil core with an ohmmeter.
2. If it conducts, replace the armature.
3. Check the continuity across the segments of the commutator with an ohmmeter.
4. If it does not conduct, replace the armature.

W1017767

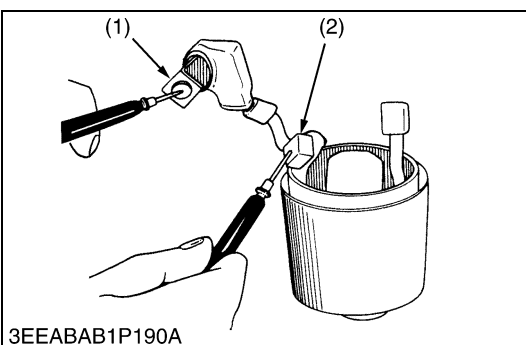
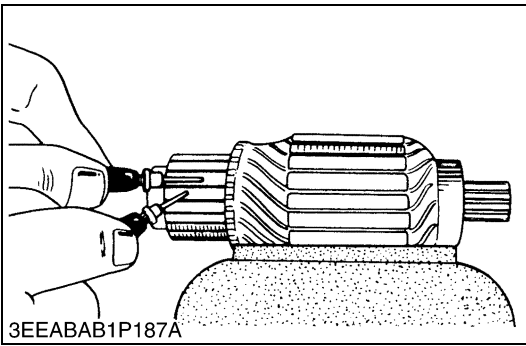

Field Coil

1. Check the continuity across the lead (1) and brush (2) with an ohmmeter.
2. If it does not conduct, replace the yoke assembly.
3. Check the continuity across the brush (2) and yoke (3) with an ohmmeter.
4. If it conducts, replace the yoke assembly.

(1) Lead
(2) Brush

(3) Yoke

W1018015

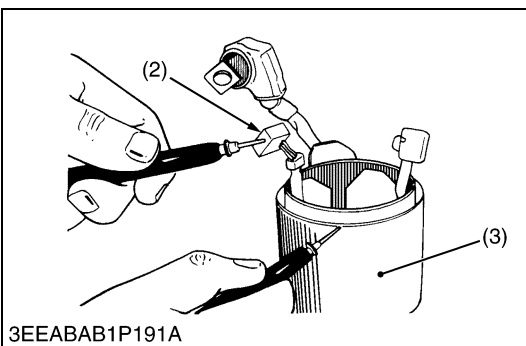

(2) Alternator

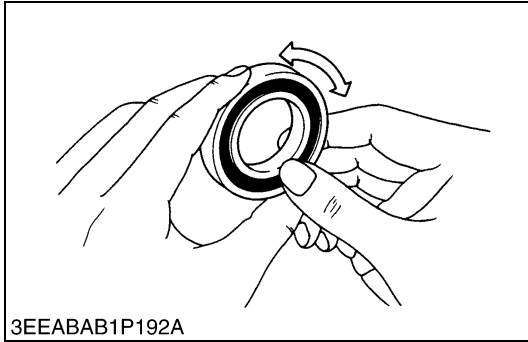

Bearing

1. Check the bearing for smooth rotation.
2. If it does not rotate smoothly, replace it.

W1019790

Alternator Components

1. When the alternator does not generator or does not charge the battery, replace the alternator as an assembly.

W1060576

7 MOWER

SAFETY DECALS

The following safety decals are installed on the mower.

If a decal becomes damaged, illegible or is not on the mower, replace it. The decal part number is listed in the parts list.

[RCK60B-23BX, RCK54-23BX, RCK48-18BX]

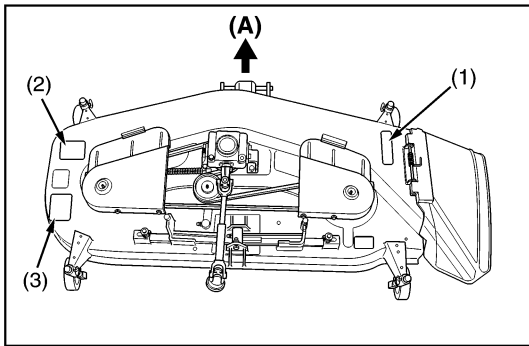

(A) Forward

(1) Part No. K5112-7311-1



1BDACADAP003E

(3) Part No. K5763-4715-1



1BDACADAP002E

(2) Part No. K5112-7312-1



1BDACADAP004E

3TAAAKCP002A

[RCK54P-23BX]

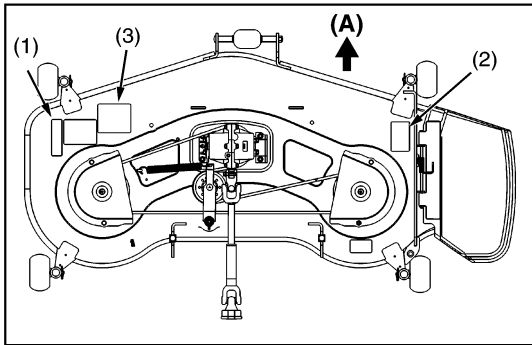

(A) Forward

(1) Part No. K5617-7311-1



1BDABBSAP0030

(2) Part No. K5617-7312-1



1BDABBSAP0020

(3) Part No. K5763-4715-1



1BDACADAP002E

3TAAAKCP003A

[RCK48P-18BX]

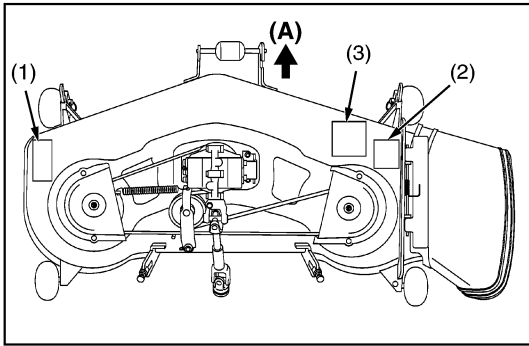

(A) Forward

(1) Part No. K5617-7311-1



1BDABBSAP0030

(3) Part No. K5763-4715-1



1BDACADAP002E

(2) Part No. K5617-7312-1



1BDABBSAP0020

CARE OF DANGER, WARNING AND CAUTION LABELS

1. Keep danger, warning and caution labels clean and free from obstructing material.
2. Clean danger, warning and caution labels with soap and water, dry with a soft cloth.
3. Replace damaged or missing danger, warning and caution labels with new labels from your local KUBOTA dealer.
4. If a component with danger, warning or caution label (s) affixed is replaced with new part, make sure new label (s) is (are) attached in the same location (s) as the replaced component.
5. Mount new danger, warning and caution labels by applying on a clean dry surface and pressing any bubbles to outside edge.

3TAAAKCP004A

SPECIFICATIONS

Model		RCK60B-23BX	RCK54P-23BX	RCK54-23BX	RCK48P-18BX	RCK48-18BX
Suitable tractor		BX2360 BX2660	BX2360	BX1860 BX2360	BX1860	
Mounting method		Quick-Joint, Parallel linkage				
		Self-balance suspended linkage	Suspended linkage			
Adjustment of cutting height		Dial gauge				
Cutting width		1524 mm (60 in.)	1375 mm (54 in.)	1372 mm (54 in.)	1225 mm (48 in.)	1219 mm (48 in.)
Cutting height		25 to 102 mm (1.0 to 4.0 in.)				
Weight (Approx.)		115 kg (250 lbs)	86 kg (190 lbs)	95 kg (210 lbs)	82 kg (181 lbs)	75 kg (165 lbs)
Blade spindle speed		44.1 r/s (2647 rpm)	49.5 r/s (2969 rpm)		54.7 r/s (3281 rpm)	
Blade tip velocity		72.5 m/s (14271 fpm)	73.8 m/s (14527 fpm)		72.8 m/s (14331 fpm)	
Blade length		523 mm (20.6 in.)	475 mm (18.7 in.)		424 mm (16.7 in.)	
Number of blades		3				
Dimensions	Overall length	1000 mm (39.4 in.)	908 mm (35.7 in.)	928 mm (36.5 in.)	881 mm (34.7 in.)	895 mm (35.2 in.)
	Overall width	1930 mm (76.0 in.)	1700 mm (67.0 in.)	1780 mm (66.5 in.)	1550 mm (61.0 in.)	1544 mm (60.8 in.)
	Overall height (Min.)	281 mm (11.0 in.)	291 mm (11.5 in.)	281 mm (11.0 in.)	291 mm (11.5 in.)	268 mm (10.5 in.)

W1028770

GENERAL

CONTENTS

1. MOWER IDENTIFICATION.....	7-G1
2. LUBRICANTS	7-G2
3. TIGHTENING TORQUES	7-G3
4. MAINTENANCE CHECK LIST.....	7-G5
5. CHECK AND MAINTENANCE.....	7-G6
[1] CHECK POINTS OF DAILY OR EACH USE.....	7-G6
[2] CHECK POINT OF INITIAL 50 HOURS	7-G8
[3] CHECK POINT OF EVERY 150 HOURS	7-G8
[4] CHECK POINT OF EVERY 2 YEARS	7-G9
6. SETTING UP MOWER	7-G10
7. MOWER ADJUSTMENT	7-G13

1. MOWER IDENTIFICATION

When contacting your local KUBOTA distributor, always specify mower serial number.

(1) Mower Serial Number

**A : RCK60B-23BX, RCK54P-23BX,
RCK54-23BX, RCK48-18BX
B : RCK48P-18BX**

W1020623

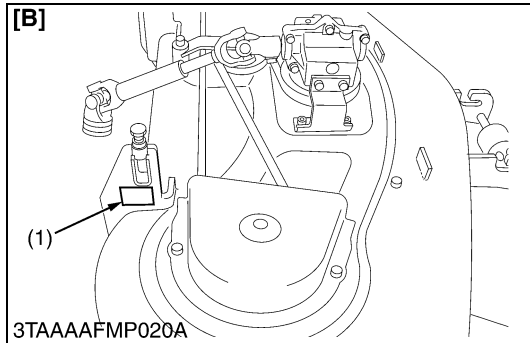
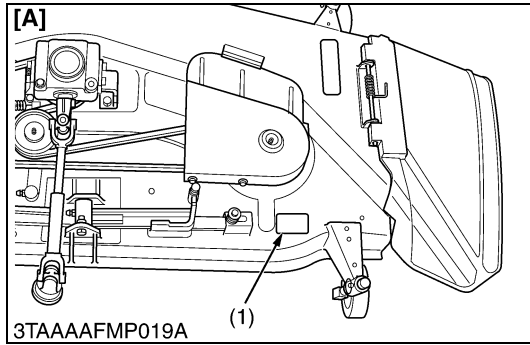



2. LUBRICANTS

No.	Place	Capacity	Lubricants
1	Gear Box	RCK60B-23BX 0.36 L	SAE 90 gear oil (API Service GL-5 gear oil)
		RCK54-23BX 0.38 U.S.qts	
RCK48-18BX 0.32 Imp.qts			
RCK54P-23BX 0.15 L			
		RCK48P-18BX 0.16 U.S.qts	
		0.13 Imp.qts	
Greasing			
2	Universal joint	Until grease overflows.	SAE multi-purpose type grease NLGI-2 or NLGI-1(GC-LB)
3	Three spindle shafts		
4	Belt tension pulley		
5	Belt tension pivot		
6	Balance shaft (RCK60B-23BX only)		
7	Front and rear anti-scalp roller		

3. TIGHTENING TORQUES

Screws, bolts and nuts whose tightening torques are not specified in this Workshop Manual should be tightened according to the table below.

■ GENERAL USE SCREWS, BOLTS AND NUTS

Indication on top of bolt	 No-grade or 4T						 7T						 9T		
Material of bolt	SS400, S20C						S43C, S48C						SCr435, SCM435		
Material of opponent part	Ordinariness			Aluminum			Ordinariness			Aluminum			Ordinariness		
Diameter \ Unit	N·m	kgf·m	lbf·ft	N·m	kgf·m	lbf·ft	N·m	kgf·m	lbf·ft	N·m	kgf·m	lbf·ft	N·m	kgf·m	lbf·ft
M6 (6 mm, 0.24 in.)	7.9 to 9.3	0.80 to 0.95	5.8 to 6.8	7.9 to 8.8	0.80 to 0.90	5.8 to 6.5	9.81 to 11.2	1.00 to 1.15	7.24 to 8.31	7.9 to 8.8	0.80 to 0.90	5.8 to 6.5	12.3 to 14.2	1.25 to 1.45	9.05 to 10.4
M8 (8 mm, 0.31 in.)	18 to 20	1.8 to 2.1	13 to 15	17 to 19	1.7 to 2.0	13 to 14	24 to 27	2.4 to 2.8	18 to 20	18 to 20	1.8 to 2.1	13 to 15	30 to 34	3.0 to 3.5	22 to 25
M10 (10 mm, 0.39 in.)	40 to 45	4.0 to 4.6	29 to 33	32 to 34	3.2 to 3.5	24 to 25	48 to 55	4.9 to 5.7	36 to 41	40 to 44	4.0 to 4.5	29 to 32	61 to 70	6.2 to 7.2	45 to 52
M12 (12 mm, 0.47 in.)	63 to 72	6.4 to 7.4	47 to 53	-	-	-	78 to 90	7.9 to 9.2	58 to 66	63 to 72	6.4 to 7.4	47 to 53	103 to 117	10.5 to 12.0	76.0 to 86.7
M14 (14 mm, 0.55 in.)	108 to 125	11.0 to 12.8	79.6 to 92.5	-	-	-	124 to 147	12.6 to 15.0	91.2 to 108	-	-	-	167 to 196	17.0 to 20.0	123 to 144
M16 (16 mm, 0.63 in.)	167 to 191	17.0 to 19.5	123 to 141	-	-	-	197 to 225	20.0 to 23.0	145 to 166	-	-	-	260 to 304	26.5 to 31.0	192 to 224
M18 (18 mm, 0.71 in.)	246 to 284	25.0 to 29.0	181 to 209	-	-	-	275 to 318	28.0 to 32.5	203 to 235	-	-	-	344 to 402	35.0 to 41.0	254 to 296
M20 (20 mm, 0.79 in.)	334 to 392	34.0 to 40.0	246 to 289	-	-	-	368 to 431	37.5 to 44.0	272 to 318	-	-	-	491 to 568	50.0 to 58.0	362 to 419



W1034542

■ STUD BOLTS

Material of opponent part	Ordinariness			Aluminum		
Diameter \ Unit	N·m	kgf·m	lbf·ft	N·m	kgf·m	lbf·ft
M8 (8 mm, 0.31 in.)	12 to 15	1.2 to 1.6	8.7 to 11	8.9 to 11	0.90 to 1.2	6.5 to 8.6
M10 (10 mm, 0.39 in.)	25 to 31	2.5 to 3.2	18 to 23	20 to 25	2.0 to 2.6	15 to 18
M12 (12 mm, 0.47 in.)	29.5 to 49.0	3.0 to 5.0	21.7 to 36.1	31.4	3.2	23.1



W1048139

AMERICAN STANDARD SCREWS, BOLTS AND NUTS WITH UNC OR UNF THREADS

Grade	SAE GR.5 			SAE GR.8 			
	Unit	N·m	kgf·m	lbf·ft	N·m	kgf·m	lbf·ft
5/16		23.1 to 27.7	2.35 to 2.83	17.0 to 20.5	32.6 to 39.3	3.32 to 4.00	24.0 to 29.0
3/8		48 to 56	4.9 to 5.8	35.0 to 42.0	61.1 to 73.2	6.23 to 7.46	45.0 to 54.0
1/2		109 to 130	11.1 to 13.2	80.0 to 96.0	149.2 to 178.9	15.21 to 18.24	110.0 to 132.0
9/16		149.2 to 178.9	15.21 to 18.24	110.0 to 132.0	217.0 to 260.3	22.12 to 26.54	160.0 to 192.0
5/8		203.4 to 244	20.74 to 24.88	150.0 to 180.0	298.3 to 357.9	30.42 to 36.49	220.0 to 264.0

W1022485

PLUGS

Shape	Size	Material of opponent part					
		Ordinariness			Aluminum		
		N·m	kgf·m	lbf·ft	N·m	kgf·m	lbf·ft
Tapered screw 	R1/8	13 to 21	1.3 to 2.2	9.4 to 15	13 to 21	1.3 to 2.0	9.4 to 15
	R1/4	25 to 44	2.5 to 4.5	18 to 32	25 to 34	2.5 to 3.5	18 to 25
Straight screw 	G1/4	25 to 34	2.5 to 3.5	18 to 25	–	–	–
	G3/8	62 to 82	6.3 to 8.4	46 to 60	–	–	–
	G1/2	49 to 88	5.0 to 9.0	37 to 65	–	–	–

000001666E

4. MAINTENANCE CHECK LIST

To keep the mower working in good condition as well as to avoid any accident and trouble, carry out periodic inspection and maintenance. Check the following points before use.

No.	Item	Period	Service Interval				Reference page
		Daily check	Every 50 hrs	Every 150 hrs	Every 2 years		
1	Oil leakage check	☆					7-G6
2	Make sure blade bolts are tight	☆					7-S5
3	Blade wear check	☆					7-S4
4	All hardware check	☆					-
5	Make sure all pins are in place	☆					-
6	Mower deck cleaning	☆					-
7	Greasing universal joint	☆					7-G6, G7
8	Greasing three spondle shafts	☆					7-G6, G7
9	Greasing belt tension pulley	☆					7-G6, G7
10	Greasing balance shaft	☆					7-G6, G7
11	Greasing front and rear anti-scalp rollers	☆					7-G6, G7
12	Gear box oil check	☆					7-G6
13	Gear box oil change		★		☆		7-G8
14	Gear box oil seal charge					☆	7-G9

■ IMPORTANT

- The jobs indicated by ★ must be done after the first 50 hours of operation.

W1035769

5. CHECK AND MAINTENANCE

[1] CHECK POINTS OF DAILY OR EACH USE

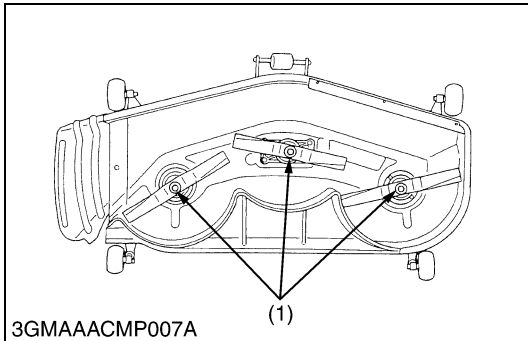

Retightening Mower Blade Screw

⚠ CAUTION

- **To avoid injury, always handle the mower blade with care.**
1. Dismount the mower and turn it over to expose the mower blades.
 2. Wedge a block of wood securely between the mower blade and mower deck.
 3. Retighten the mower blade screw to the specified torque.
 4. If the mower blade screw is worn or broken, replace it.

Tightening torque	Mower blade screw	98.1 to 117 N·m 10.0 to 12.0 kgf·m 72.4 to 86.7 lbf·ft
-------------------	-------------------	--

(1) Mower Blade Screw

W12345678

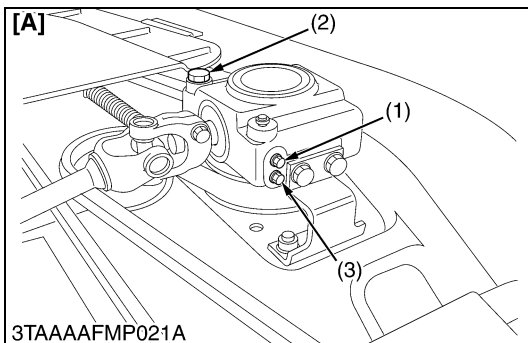

Checking Gear Box Oil Level

1. Place the mower on level ground.
2. Loosen the check plug (1), and check to see if oil seems from the opening.
3. If the oil level is low, remove the oil filler plug (2) and add new gear oil.

■ IMPORTANT

- **Use the specified gear oil.**
Refer to “LUBRICANTS”. (See page 7-G2.)

- (1) Check Plug
- (2) Oil Filler Plug
- (3) Drain Plug

[A] RCK60B-23BX, RCK54-23BX,
RCK48-18BX

[B] RCK48P-18BX, RCK54P-23B

W12378945

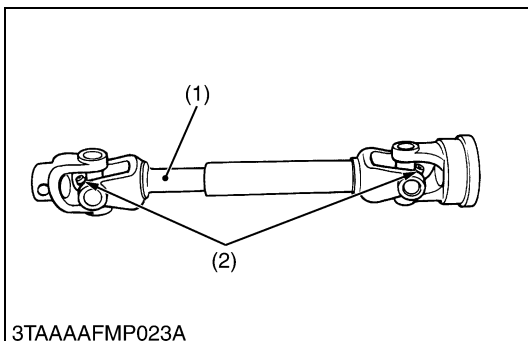
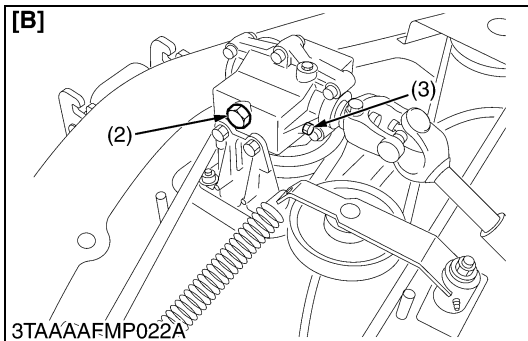

Greasing Universal Joint

1. Grease the internal splines (1) and grease nipples (2) of the universal joint if the amount of grease is insufficient.

(1) Spline

(2) Grease Nipple

W78945645

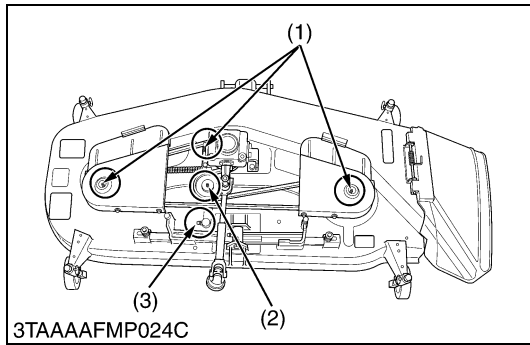

Greasing Spindle Shafts, Belt Tension Pivot and Tension Pulley

1. Grease the grease nipples (1), (2) of the spindle shafts if the amount of grease is insufficient.

- (1) Grease Nipple (Spindle Shaft)
- (2) Grease Nipple (Belt Tension Pulley)
- (3) Grease Nipple (Belt Tension Pivot)

W98745632

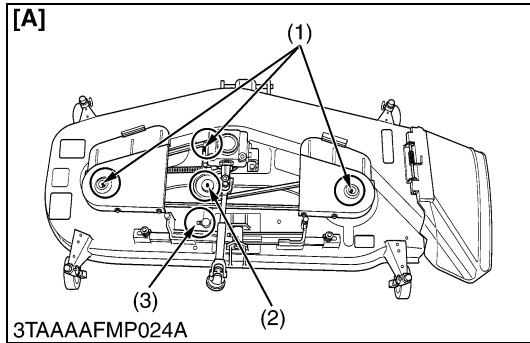

Greasing Spindle Shafts, Belt Tension Pivot and Tension Pulley

1. Grease the grease nipples (1), (2) of the spindle shafts if the amount of grease is insufficient.

- (1) Grease Nipple (Spindle Shaft)
 - (2) Grease Nipple (Belt Tension Pulley)
 - (3) Grease Nipple (Belt Tension Pivot)
- [A] RCK60B-23BX, RCK54-23BX, RCK48-18BX**
[B] RCK54P-23BX, RCK48P-18BX

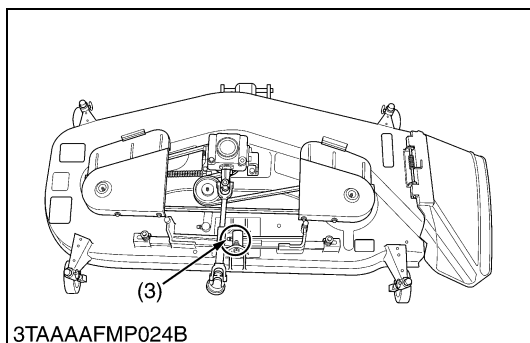
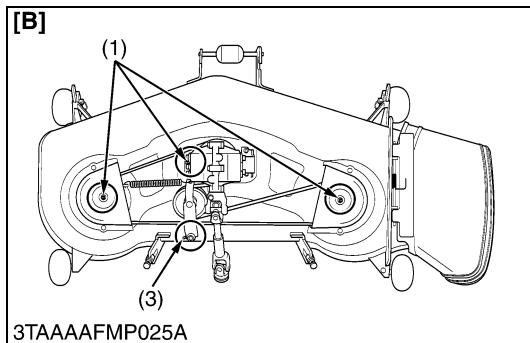

Greasing Balance Shaft [RCK60B-23BX]

1. Grease the grease nipple (1) of the balance shaft if the amount of grease is insufficient.

- (1) Grease Nipple

W74136985

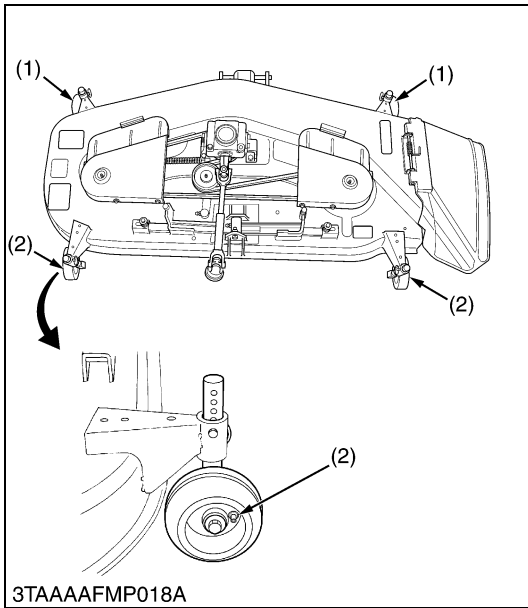

Greasing Front and Rear Anti-scalp Rollers [RCK60B-23BX, RCK54P-23BX, RCK54-23BX]

1. Grease the grease nipple (1), (2) of the front and rear anti-scalp rollers if the amount of grease is insufficient.

- (1) Grease Nipple (Front Anti-scalp Roller) (2) Grease Nipple (Rear Anti-scalp Roller)

W1026897

[2] CHECK POINT OF INITIAL 50 HOURS

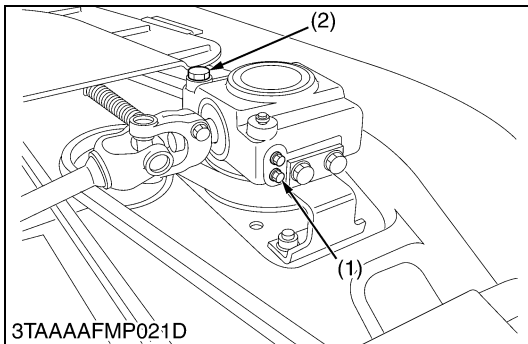

Changing Gear Box Oil

⚠ CAUTION

- Be sure to stop the engine and remove the key before changing the oil.

1. Dismount the mower from the tractor, and place the mower on level ground.
2. Remove the oil filler plug (2).
3. Remove the drain plug (1), and drain the used oil completely.
4. After draining the used oil, reinstall the drain plug.
5. Fill with new oil up to the specified level.

■ IMPORTANT

- Use the specified gear oil.
Refer to "LUBRICANTS". (See page 7-G2.)

- (1) Drain Plug (2) Oil Filter Plug

W1027307

[3] CHECK POINT OF EVERY 150 HOURS

Changing Gear Box Oil

1. See above.

W1027627

[4] CHECK POINT OF EVERY 2 YEARS

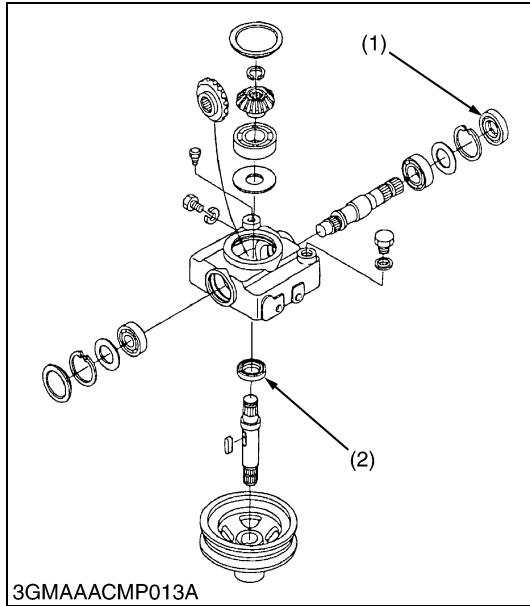

Replacing Gear Box Oil Seal

1. Replace the gear box oil seals (1), (2) with new ones.

(1) Oil Seal

(2) Oil Seal

W1027687

6. SETTING UP MOWER

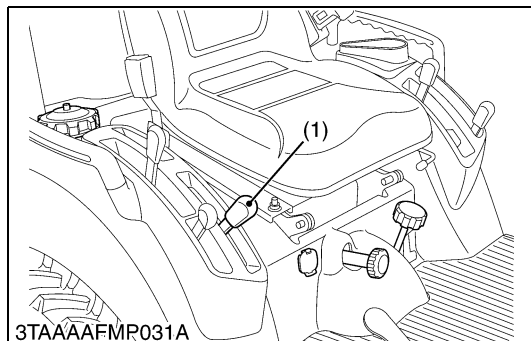
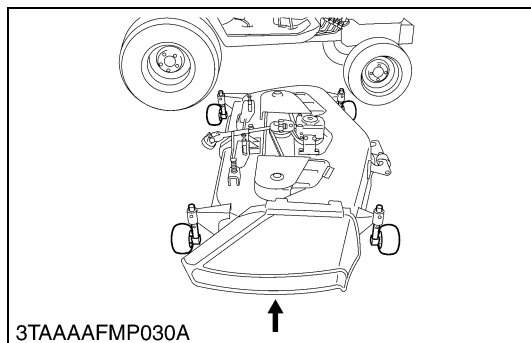
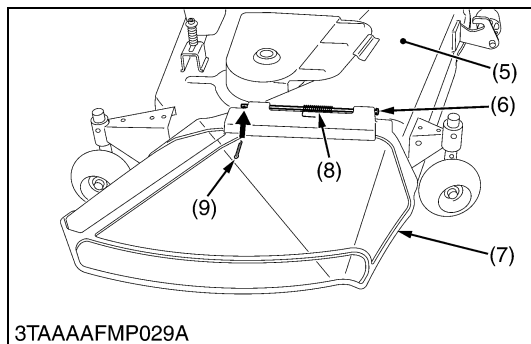
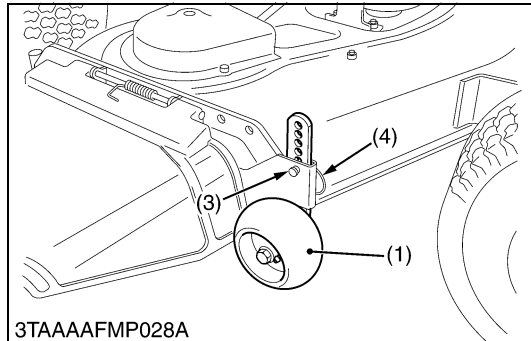
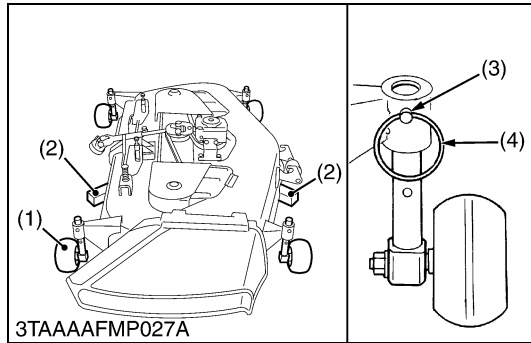

Assembling Mower

- Place the mower on blocks as illustrated.
Turn the anti-scalp rollers sideways and attach to the arms of the deck at the upper position with clevis pins and snap rings.
Remove the blocks. (RCK60B-23BX, RCK54P-23BX, RCK54-23BX)
- Attach the front anti-scalp rollers to the deck with clevis pins and snap rings. (RCK48P-18BX, RCK48-18BX)
- Attach the discharge to the deck with the spring, discharge pin and cotter pin.
Secure the spring to the discharge deflector as illustrated.

- | | |
|-----------------------|-------------------------|
| (1) Anti-scalp Roller | (6) Discharge Pin |
| (2) Block | (7) Discharge Deflector |
| (3) Clevis Pin | (8) Spring |
| (4) Snap Ring | (9) Cotter Pin |
| (5) Deck | |

W85236974

Setting Mower

CAUTION

- Park the tractor on a firm, flat and level surface, set the parking brake, stop the engine and remove the key.

- Start the engine and the hydraulic lever rearward to raise the mower rear link to the highest position.
- Stop the engine and remove the key.
- Roll the mower under the tractor from right side.

- (1) Hydraulic Control Lever

W96321478

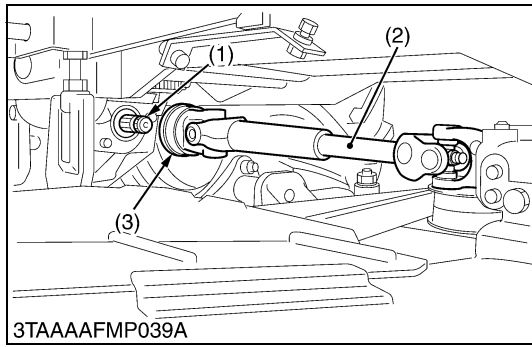

Universal Joint

1. Pull back the coupler (3) of the universal joint (2).
2. Push the universal joint (2) onto the mid-PTO shaft (1), until the coupler locks.
3. Slide the universal joint back and forward to make sure the universal joint is locked securely.

IMPORTANT

- **Finally, tug on the universal joint to make sure it is locked on the PTO shaft.**

- (1) Mid-PTO Shaft
- (2) Universal Joint
- (3) Coupler

A : Tug

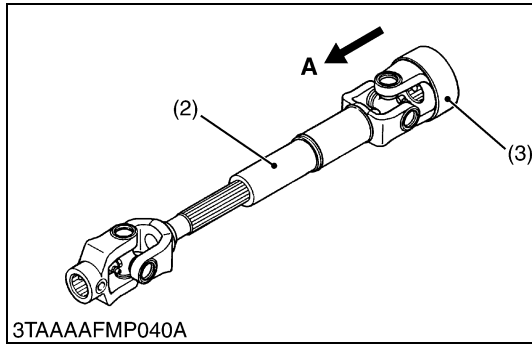

W69724158

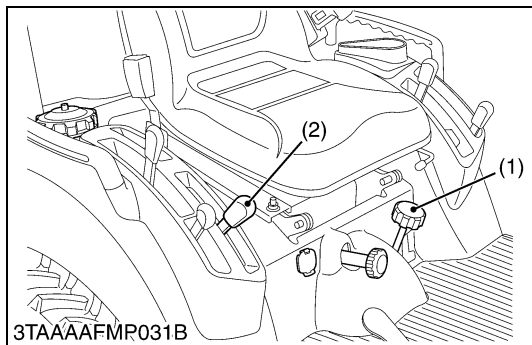

Rear Link

1. Set the cutting height control dial (1) to zero inch position.
 2. Operate the tractor's hydraulic control lever (2) forward to lower the mower rear links (3).
- Attach the rear link (3) to the mower with the L-pins (4).

- (1) Cutting Height Control Dial
- (2) Hydraulic Control Lever
- (3) Rear Link
- (4) L-pin

W96472687

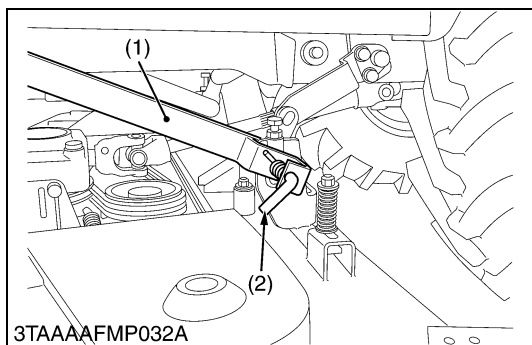

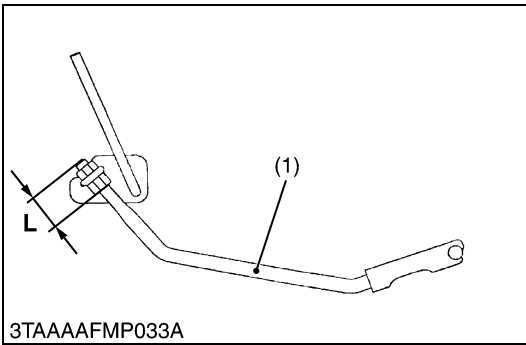

Front Link

1. Hook the front link (1) to the front bracket groove (2) as shown in the figure.

(Reference)

- Make sure the length (L) of the front link (1) is 47 mm (1.85 in.).

(1) Front Link

(2) Front Bracket Groove

W74569821

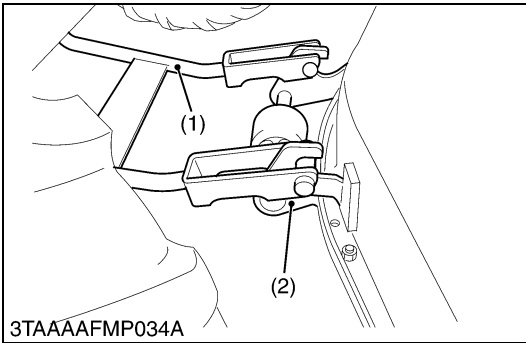

Mounting Front Link

1. Position the front lever to the front link bracket.
2. Pull and lock the L pin. Then lower the front lever.
3. Hook the front link to the lever fulcrum, and lift the front lever.
4. Release the L pin to lock the front lever.

■ **NOTE**

- When hooking the front link to the lever fulcrum, normal position of the lever fulcrum groove is open to downward.

■ **IMPORTANT**

- Check that the front lever is locked securely with the L pin.

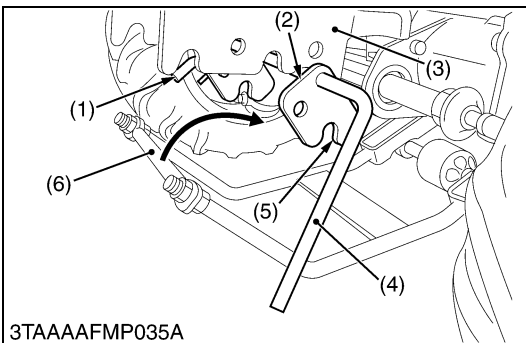

(1) L pin

(4) Front Lever

(2) Lever Fulcrum

(5) Lever Fulcrum Groove

(3) Front Link Bracket

(6) Front Link

W1028530

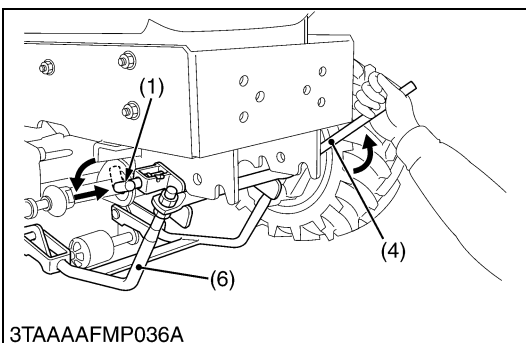

7. MOWER ADJUSTMENT



CAUTION

- Park the tractor on a firm, flat and level surface and set the parking brake.
- Stoop the engine, remove the key, and allow the blades to stop before making adjustments.
- Wear heavy gloves or wrap end of blade with a rag when you handle blades.
- Before starting the engine, set the PTO clutch lever to off position and range gear shift lever to the neutral position.

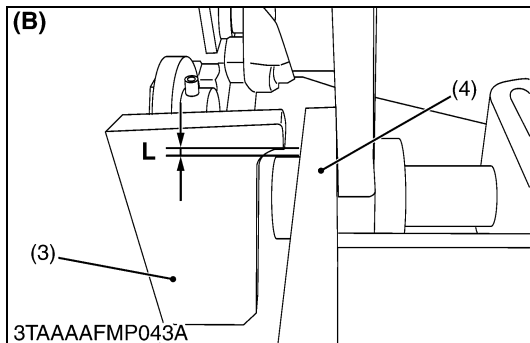
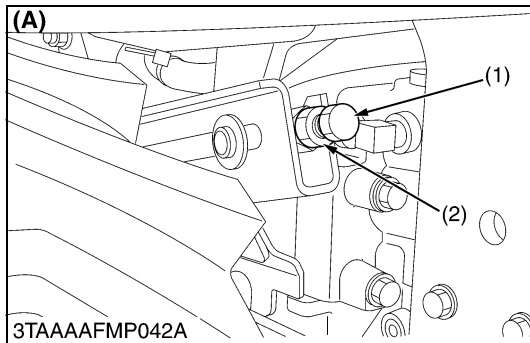
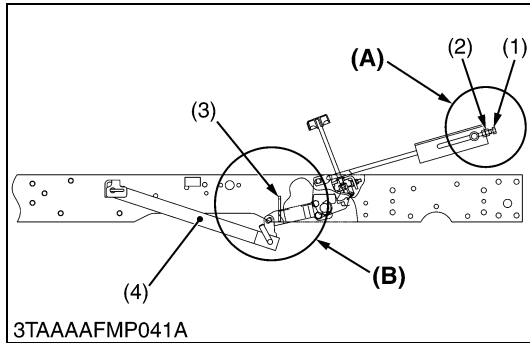

Adjusting Mower Link

1. Tire pressure must be correct.
2. Move the hydraulic control lever rearward to raise the mower to the highest position.
3. Stop the engine and remove the key.
4. Adjust the left side links with bolt so that the clearance **L** is as follows.

Clearance (L) between stopper and rear link	Factory spec.	0 to 0.5 mm 0 to 0.01 in.
---	---------------	------------------------------

- (1) Bolt
- (2) Lock Nut
- (3) Stopper
- (4) Rear Link

L : 0 to 0.5 mm (0 to 0.01 in.)
(A) Adjustment Point
(B) Check Point

W8796512

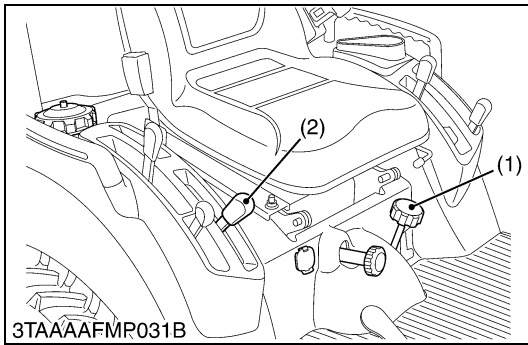

Adjusting Front and Rear Cutting Height

1. Tire pressure must be correct.
2. Make sure the level of the mower blades is adjusted as shown below. Then tighten the lock nuts securely.
3. Turn the cutting height control dial to "2.0" and the anti-scalp roller's height to keep clearance between rollers and ground from 6 to 13 mm (0.25 to 0.5 in.).
4. Turn right blade by hand parallel to direction of travel.
5. Adjust (L) of front links with lock nuts so that A is 0 to 5 mm (0 to 0.2 in.) $A = (R)-(F)$.
6. If the difference between front tip and rear tip of blade is not within the factory specification, adjust the length L of front link with lock nut (3). The height of rear blade tip R should be bigger than the front.

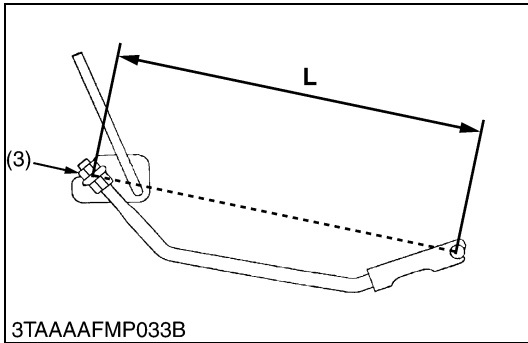

Difference (R-F) ($R \geq F$) between front tip and rear tip of blade	Factory spec.	0.0 to 5.0 mm 0.0 to 0.20 in.
---	---------------	----------------------------------

- (1) Cutting Height Control Dial
- (2) Hydraulic Control Lever
- (3) Lock Nut

- L : Length of Front Link
- F : Height of Blade Tip (Front)
- R : Height of Blade Tip (Rear)

W98765412

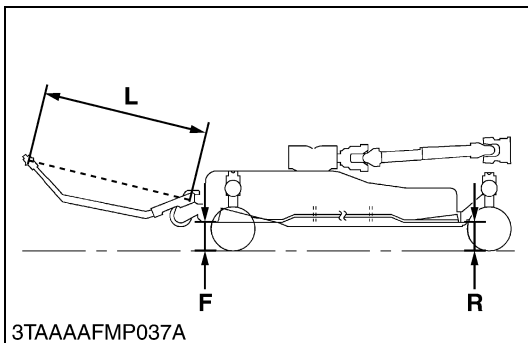

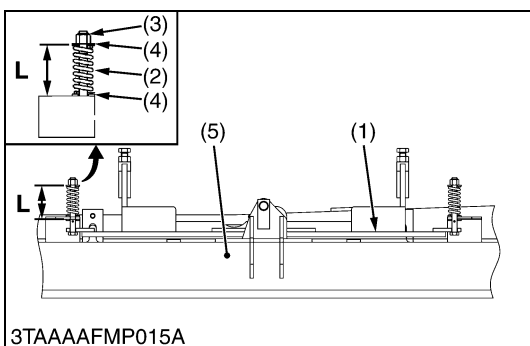
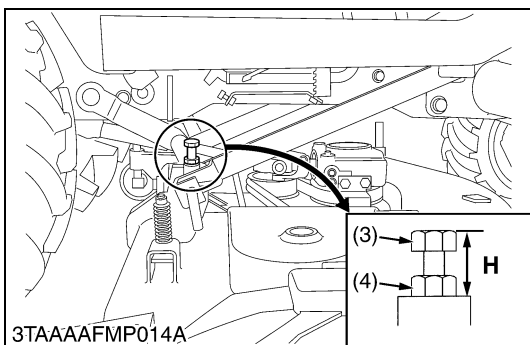
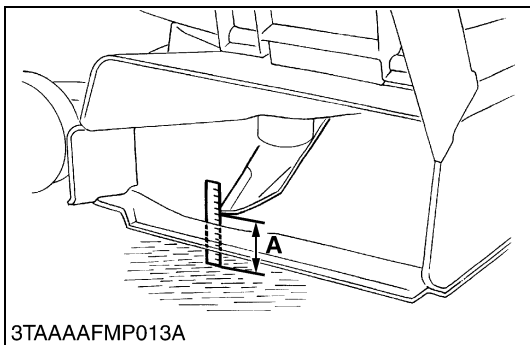
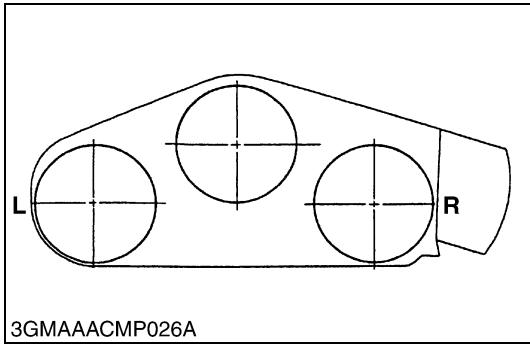
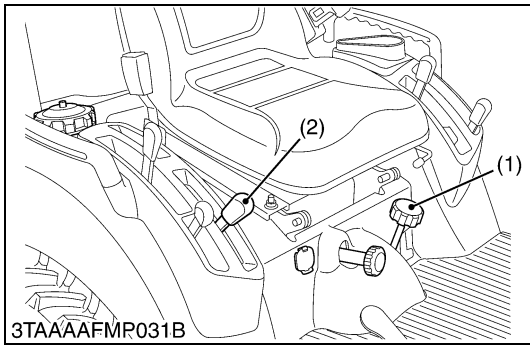

Adjusting Left and Right Cutting Height

1. Tire pressure must be correct.
2. Operate the hydraulic control lever (2) rearward to raise the mower deck to the highest position.
3. Stop the engine and remove the key.
4. Turn the cutting height control dial to the desired height.
5. Set the anti-scalp roller's height to keep clearance between rollers and ground from 6 to 13 mm (0.2 to 0.5 in.).
6. Lower the mower deck by moving the hydraulic control lever forward.
7. Turn left blade by hand parallel to tractor axle and turn right blade parallel to axle to measure from the outside blade tip at **L** and **R** to the level surface.
8. The difference between measurement should be less than 3 mm (0.12 in.).
9. If the difference between measurement is more than 3 mm (0.12 in.), loosen the lock nut of the left side.
10. Adjust the cutting height fine turning bolts so that the difference between measurement **L** and **R** is less than 3 mm (0.12 in.). Then lock the nut.

Difference (L-R) between left tip and right tip of blade	Factory spec.	Less than 3 mm 0.12 in.
--	---------------	----------------------------

- (1) Cutting Height Control Dial
- (2) Hydraulic Control Lever
- (3) Cutting Height Fine Turning Bolt
- (4) Lock Nut
- L : Left Blade Measurement Position**
- R : Right Blade Measurement Position**
- A : Blade Height**

W12398745

Adjusting Self-Balance Suspended Linkage [RCK60B-23BX only]

1. Check the length (L) of balancer spring (2).
2. If the length (L) is not within the factory specification, adjust the length of balancer spring (2) with lock nut (3).

NOTE

- Check the left and right cutting height difference after adjusting the self-balancer linkage.

Balancer spring length (L) (Right and left)	Factory spec.	55.0 mm 2.17 in.
---	---------------	---------------------

- (1) Self-Balancer
- (2) Balancer Spring
- (3) Lock Nut
- (4) Plain Washer
- (5) Mower Deck
- L : Balancer Spring Length**

W87945612

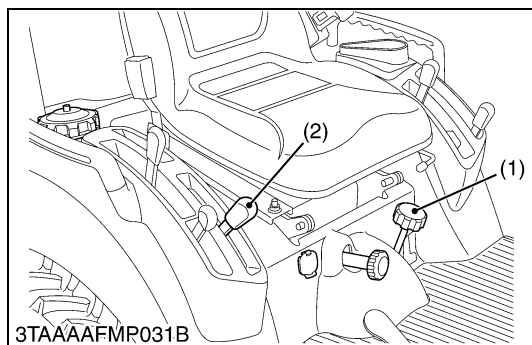

Cutting Height

⚠ DANGER

- Never operate the mower in transport position.

■ IMPORTANT

- (for self-balance suspended linkage)
To reduce the stepped difference in cutting height when mowing rolling terrain, follow the procedure below.

1. To set the cutting height, move the hydraulic control lever rearward to raise the mower to the highest position. Turn the cutting height control dial (1) to adjust height.
2. Set the anti-scalp roller's (3) height as shown to keep clearance between rollers and ground from 6 to 13 mm (0.2 to 0.5 in.).
3. Lower the mower deck by moving the hydraulic control lever (2) forward.
4. Use the higher settings for mowing in a rough area or when mowing tall grass. Lower settings should be used only for smooth lawns where short grass is desired.
5. To set the cutting height, move the hydraulic control lever (2) rearward to raise the mower to the highest position. Turn the cutting height control dial to adjust height.
6. Set the anti-scalp roller's (3) position as shown to have the same cutting height.

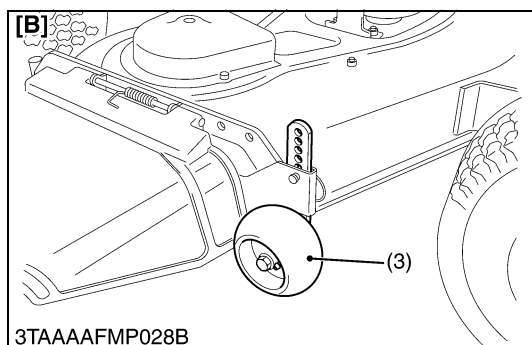
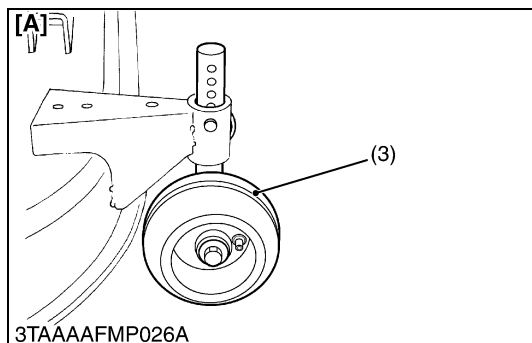
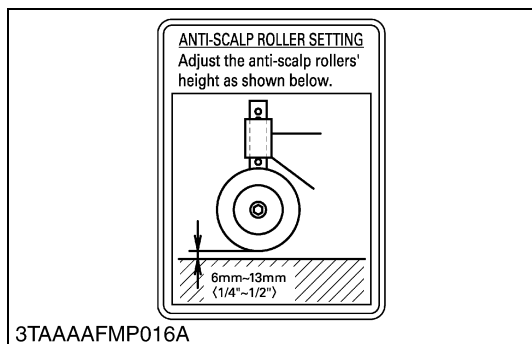

Dial (Cutting Height)	Anti-scalp Roller
25 mm (1.0 in.), 32 mm (1.25 in.)	G
38 mm (1.5 in.), 45 mm (1.75 in.)	F
51 mm (2.0 in.), 57 mm (2.25 in.)	E
64 mm (2.5 in.), 70 mm (2.75 in.)	D
76 mm (3.0 in.), 83 mm (3.25 in.)	C
89 mm (3.5 in.), 95 mm (3.75 in.)	B
102 mm (4.0 in.)	A

- (1) Cutting Height Control Dial
- (2) Hydraulic Control Lever
- (3) Anti-scalp Roller

- [A] RCK60B-23BX, RCK54P-23BX, RCK54-23BX
- [B] RCK48P-18BX, RCK48-18BX

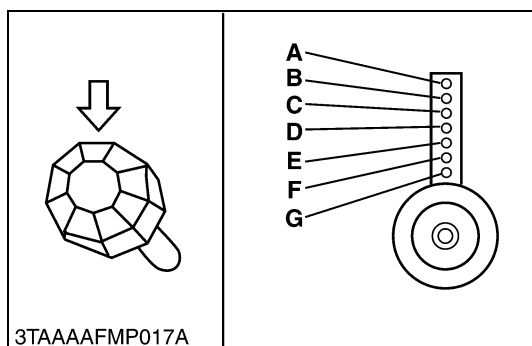

MECHANISM

CONTENTS

1. POWER TRANSMISSION	7-M1
2. LIFTING MECHANISM	7-M2
3. SELF-BALANCER SYSTEM.....	7-M3

1. POWER TRANSMISSION

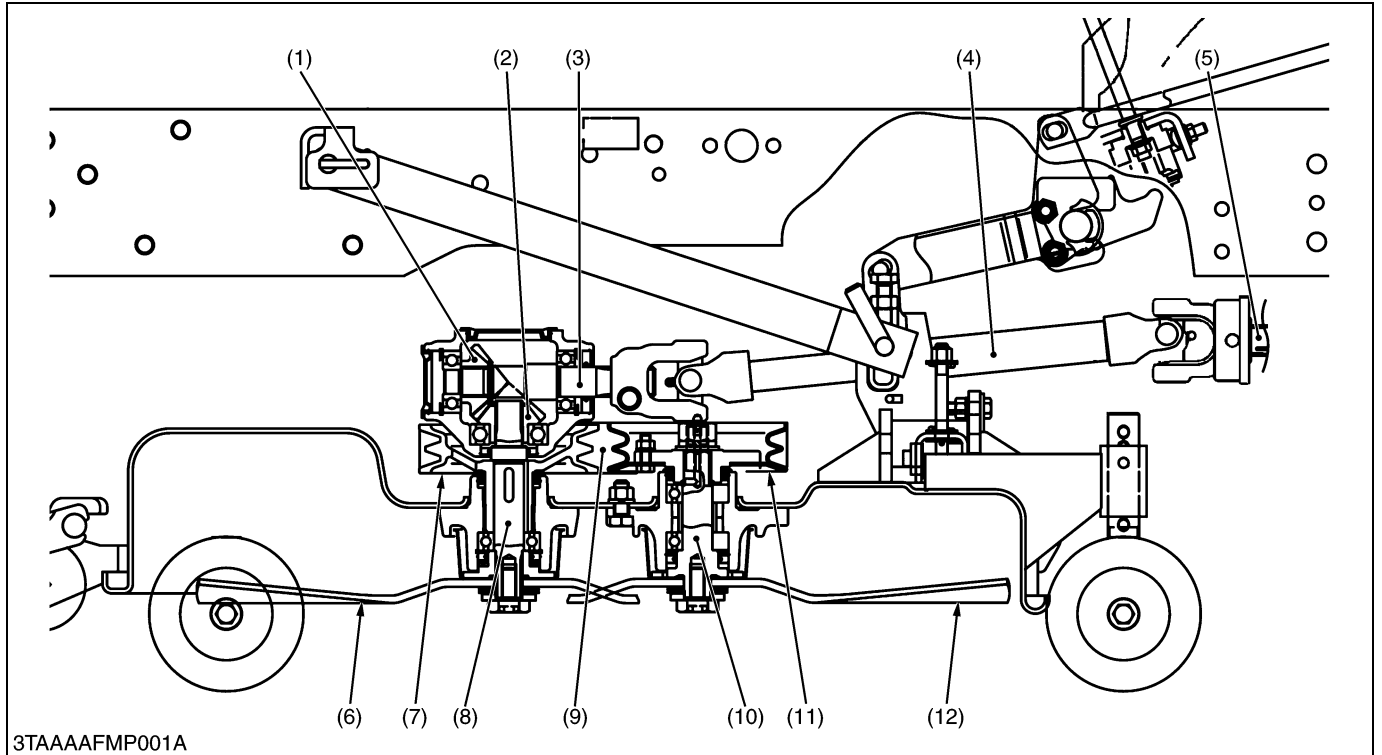

3TAAAFMP001A

- | | | | |
|--------------------|---------------------|----------------------|-------------------|
| (1) 18T Bevel Gear | (4) Universal Joint | (7) Center Pulley | (10) Blade Shaft |
| (2) 17T Bevel Gear | (5) Mid-PTO Shaft | (8) Bevel Gear Shaft | (11) Outer Pulley |
| (3) Pinion Shaft | (6) Center Blade | (9) Mower Belt | (12) Outer Blade |

The power is transmitted from mid-PTO to blades as follows:

■ **Center Blade**

Mid-PTO Shaft (5) → Universal Joint (4) → Pinion Shaft (3) → Bevel Gear (1) → Bevel Gear (2) → Bevel Gear Shaft (8) → Center Blade (6)

■ **Outer Blade**

Mid-PTO Shaft (5) → Universal Joint (4) → Pinion Shaft (3) → Bevel Gear (1) → Bevel Gear (2) → Bevel Gear Shaft (8) → Center Pulley (7) → Mower Belt (9) → Outer Pulley (11) → Blade Shaft (10) → Outer Blade (12)

2. LIFTING MECHANISM

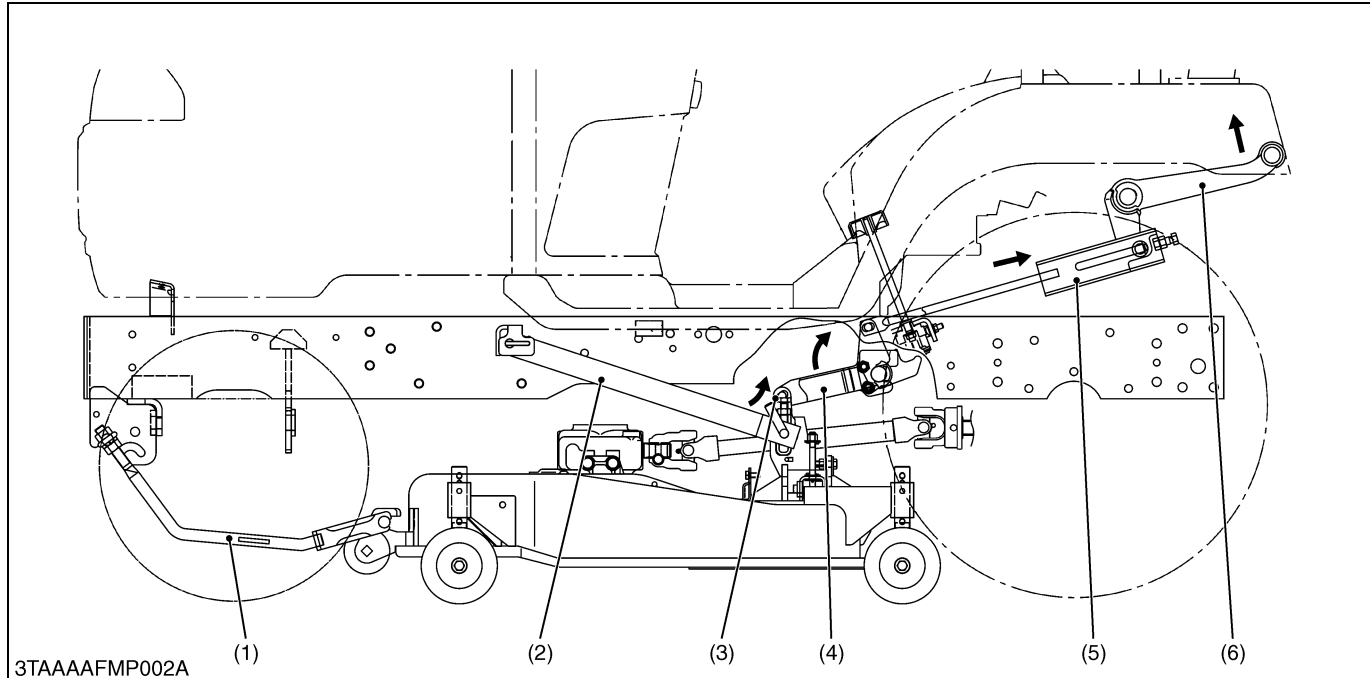

(1) Front Link
(2) Rear Link

(3) Lift Link
(4) Rear Lift Link (RH)

(5) Rear Lift Link (LH)

(6) Lift Arm

The lifting of mower is performed by the hydraulic system installed on the tractor.

The mower should be kept lift when traveling. When the position control lever is moved to “LIFT” position, the lift arm (6) is lifted up by the oil pressure of hydraulic system, and the rear lift link (LH) (5) is pulled rearward.

Therefore, rear lift links (4), (5) rotate and the mower is lifted by the lift links (3) and rear links (2).

As this link system is a parallel linkage, the mower can be kept parallel at every position.

CAUTION

- Never operate mower in transport position.

3. SELF-BALANCER SYSTEM

This system reduces the stepped differences in cutting height when mowing rolling terrain.

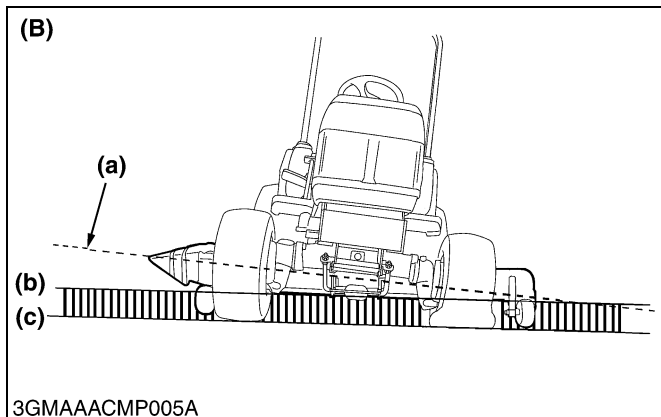
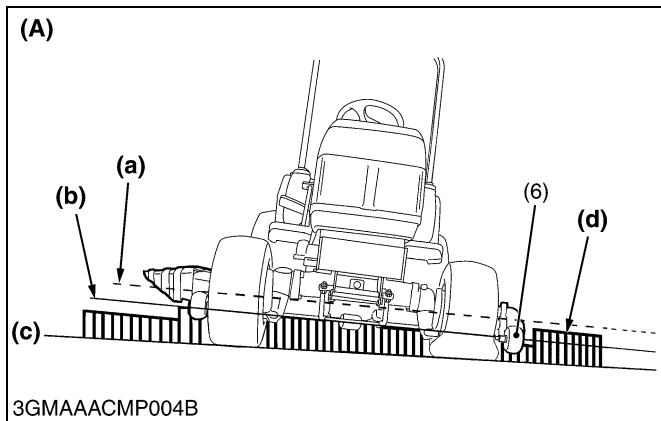
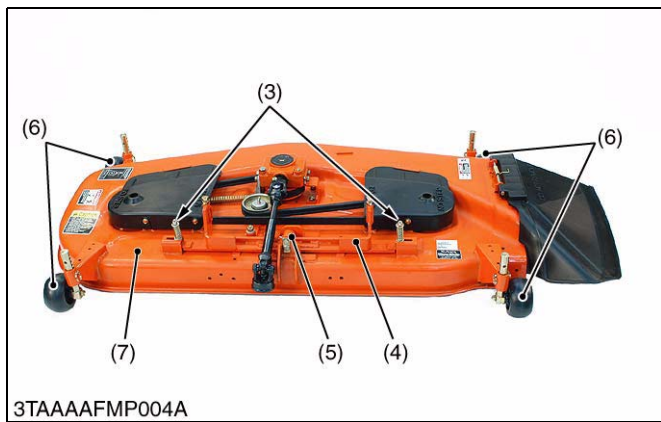
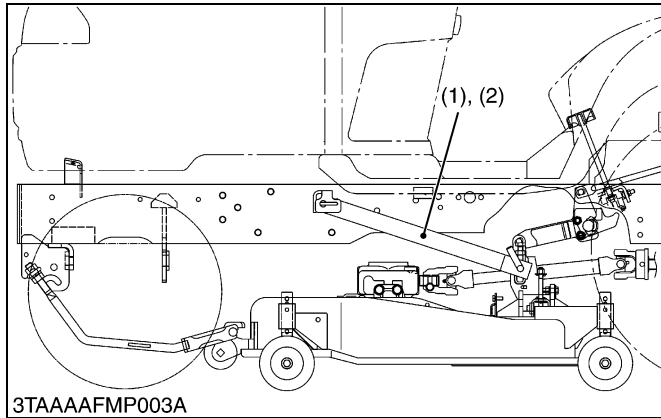

■ Self-Balancer

1. The mower deck is held in place via the balancer plate (4) and the support by the rear link (1), (2).
2. The mower deck is suspended by, and is tilted to the right and left by, the balancer support (5). The balancer springs (3) at both sides adjust themselves for suitable tension to keep the mower deck out of excessive tilt.

■ Without Self-Balancer Type (A)

- When working on a wavy ground, the tractor itself, with the mower deck, goes along the curves of the terrain. If not equipped with the self-balancer, the tractor tends to tilt itself greater than the ground's waves by its own weight. This may cause an uneven mowing. The wider the mower is, the more unevenness is caused.

■ With Self-Balancer Type (B)

- When working on a wavy ground, the tractor itself goes along the curves of the terrain like with the tractor that is not equipped with the self-balancer. The balancer springs (3), however, serve to keep the mower deck in parallel with the ground's curves until the anti-scalp roller (6) comes in contact with the ground.
- If the tractor temporarily tilts more than the ground's slope or the like, the anti-scalp roller (6) touches the ground. Now the mower deck is brought back in parallel with the ground by the counterforce of the roller (6) just hitting the ground as well as the tension of the balancer springs (3). This helps reduce an uneven mowing.

■ NOTE

- **Always keep the anti-scalp roller with specified position (Refer to Operator's Manual).**

- | | |
|-----------------------|---------------------------|
| (1) Rear Link (RH) | (A) Without Self-Balancer |
| (2) Rear Link (LH) | (B) With Self-Balancer |
| (3) Balancer Spring | (a) Tilt : Tractor |
| (4) Balancer Plate | (b) Tilt : Mower Deck |
| (5) Balancer Support | (c) Ground |
| (6) Anti-scalp Roller | (d) Grass |
| (7) Mower Deck | |

W1013200

SERVICING

CONTENTS

1. TROUBLESHOOTING	7-S1
2. SERVICING SPECIFICATIONS	7-S2
3. TIGHTENING TORQUES	7-S3
4. CHECKING, DISASSEMBLING AND SERVICING.....	7-S4
[1] CHECKING AND ADJUSTING	7-S4
[2] DISASSEMBLING AND ASSEMBLING.....	7-S5
[3] SERVICING	7-S11

1. TROUBLESHOOTING

Symptom	Probable Cause	Solution	Reference Page
Blade Does Not Turn	Mid-PTO system malfunctioning	Check transmission	2-S31, S40
	Mower belt broken	Replace mower belt	7-S4
Blade Speed Is Slow	Mower belt loosen	Replace mower belt or tension spring	7-S4
	Grass clogged	Remove grass	–
	Cup washer flattened out or worn	Replace cup washer	7-S5
	Engine rpm too low	Mow at full throttle, check and reset engine rpm	–
Cutting Is Poor	Mower blade worn or broken	Sharpen or replace mower blade	7-S5
	Mower blade screw loosen	Retighten mower blade screw	7-S5
	Cutting height improper	Adjust cutting height	7-G15
	Ground speed too fast	Slow-down	–
	Low tire inflation	Add air to correct	G-41
	Anti-scalp rollers not adjusted correctly	Adjust anti-scalp rollers	7-G16
Mower Is Not Lifted	Linkage system broken	Replace linkage system	7-G12
	Trouble of hydraulic system	Check hydraulic system	–

W1014322

2. SERVICING SPECIFICATIONS

Item		Factory Specification	Allowable Limit
Input Shaft (without Mower Belt)	Turning Force	Less than 118 N 12.0 kgf 26.5 lbf	–
	Turning Torque	Less than 1.5 N·m 0.15 kgf·m 1.1 lbf·ft	–
Bevel Gears in Gear Box [RCK48-18BX, RCK54-23BX, RCK60B-23BX]	Backlash	0.10 to 0.20 mm 0.0040 to 0.0078 in.	0.40 mm 0.016 in.
	[RCK48P-18BX, RCK54P-23BX]	Backlash	0.13 to 0.25 mm 0.0051 to 0.0098 in.

W1013874

3. TIGHTENING TORQUES

Tightening torques of screws, bolts and nuts on the table below are especially specified.
 (For general use screws, bolts and nuts: See page 7-G3.)

[RCK48-18BX, RCK54-23BX, RCK60B-23BX]

Item	N·m	kgf·m	lbf·ft
Gear box mounting screw and nut	78 to 90	7.9 to 9.2	58 to 66
Mower blade screw	103 to 117	10.5 to 12.0	76.0 to 86.7
Center pulley holder bolt and nut	78 to 90	7.9 to 9.2	58 to 66
Outer pulley mounting nut	197 to 225	20.0 to 23.0	145 to 166
Gear box bracket (RH) mounting bolt and nut	78 to 90	7.9 to 9.2	58 to 66
Pulley boss mounting nut	24 to 27	2.4 to 2.8	18 to 20
Pulley holder mounting bolt and nut	78 to 90	7.9 to 9.2	58 to 66

W1012736

[RCK48P-18BX and RCK54P-23BX]

Item	N·m	kgf·m	lbf·ft
Mower blade screw	103 to 118	10.5 to 12.0	76 to 87
Gear box screw	24 to 28	2.4 to 2.8	17 to 20
Gear box mounting screw (for aluminum gear case)	39 to 44	4.0 to 4.5	49 to 33
Gear box mounting screw and nut	77 to 90	7.9 to 9.2	57 to 67
Center pulley holder bolt and nut	77 to 90	7.9 to 9.2	57 to 67
Outer pulley mounting nut	167 to 186	17.0 to 19.0	123 to 137
Pulley holder mounting bolt and nut	77 to 90	7.9 to 9.2	57 to 67
Gear box bracket (RH) mounting screw (for aluminum gear case)	39 to 44	4.0 to 4.5	29 to 33

W1013579

4. CHECKING, DISASSEMBLING AND SERVICING

[1] CHECKING AND ADJUSTING

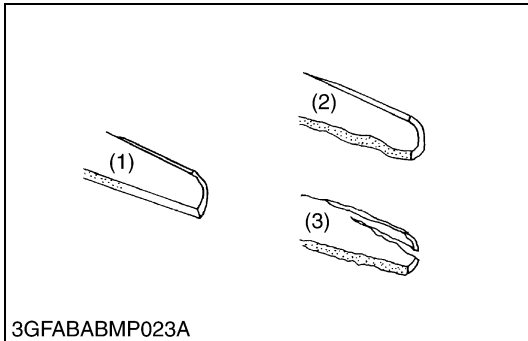

Checking Mower Blade

1. Check the cutting edge of mower blade.
2. Sharpen the cutting edges, if the mower blades are as shown in figure (2).
3. Replace the mower blades, if they are as shown in figure (3).

■ IMPORTANT

- Never forget to set the dust cover, cup washer(s) and lock washer, when reassembling the mower blades. (See page 7-S5.)

■ NOTE

- To sharpen the mower blades by yourself, clamp the mower blade securely in a vise and use a large mill file along the original bevel.
- To balance the mower blade, place a small rod through the center hole and check to see if the blade balance evenly. File heavy side of the blade until it balance out even.

(1) New Blade

(3) Cracked Blade

(2) Worn Blade

W1011041

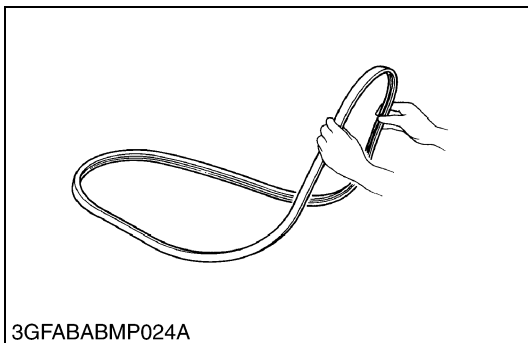

Checking Mower Belt

1. Check to see the mower belt.
2. Replace the mower belt with a new one, if there is found surface split at more than 3 positions.

(When replacing mower belt)

1. Dismount the mower from the tractor.
2. Remove the left and right hand belt cover from the mower deck.
3. Clean around the gear box.
4. Remove the right hand bracket (3) which mounts the gear box to the mower deck.
5. Remove the mower belt (2) from the tension pulley (1). Slip the mower belt over the top of the gear box.
6. To install a new belt, reverse the above procedure.

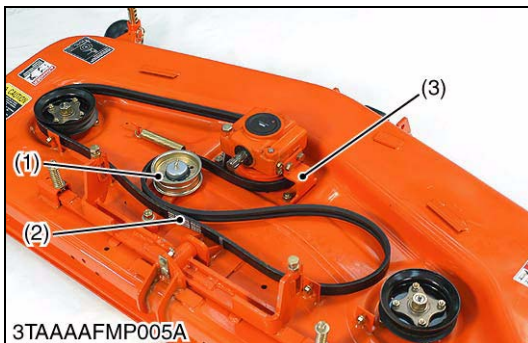

Tightening torque	Gear box bracket RH mounting bolt and nut	78 to 90 N·m 7.9 to 9.2 kgf·m 58 to 66 lbf·ft
	Gear box bracket RH mounting screw (for aluminum gear case)	39 to 44 N·m 4.0 to 4.5 kgf·m 29 to 33 lbf·ft

■ IMPORTANT

- After setting the gear box bracket mounting screws on the deck without tightening, then mount the other screws on the gear box. And finally tighten them.

(1) Tension Pulley

(3) Gear Box Bracket (Right)

(2) Mower Belt

W1011180

[2] DISASSEMBLING AND ASSEMBLING

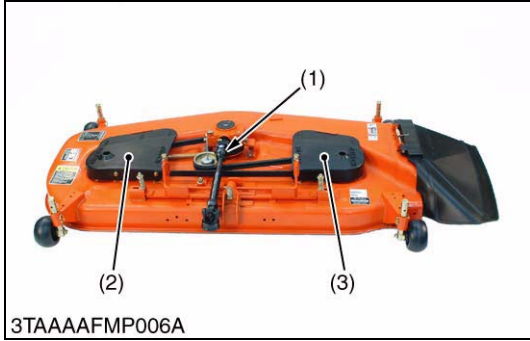

Universal Joint and Belt Cover

1. Unscrew the universal joint screw.
2. Remove the universal joint (1).
3. Remove the left and right belt covers (2), (3).

- (1) Universal Joint (3) Belt Cover (Right)
 (2) Belt Cover (Left)

W1012580



Mower Blades (Center Blade and Outer Blades)

1. Turn over the mower.
2. Unscrew the mower blade screw (5), and remove the lock washer (4), cup washer(s) (3), mower blade (2) and dust cover (1).

NOTE

- To remove the blade securely, wedge a block of wood between one blade and the mower deck in such position that it will hold the blade safely while loosening or tightening the blade screw.

(When reassembling)

[RCK48-18BX, RCK54-23BX, RCK48P-18BX, RCK54P-23BX]

- Install the blade in position together with the dust cover and the cup washer. Tighten them up with the screw.

[RCK60B-23BX]

- Install the blade in position together with the dust cover, the lock washer and the 2 cup washers. Tighten them up with the screw.

IMPORTANT

- Make sure the cup washer is not flattened out or worn, causing blade to slip easily.
Replace cup washer(s) if either is damaged.

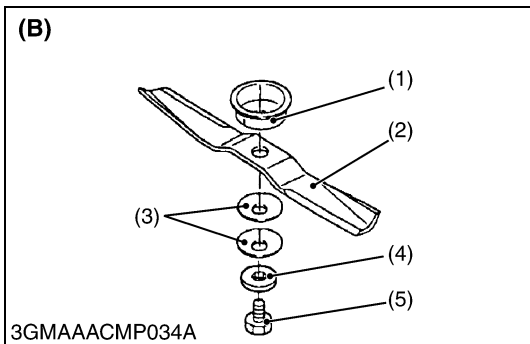
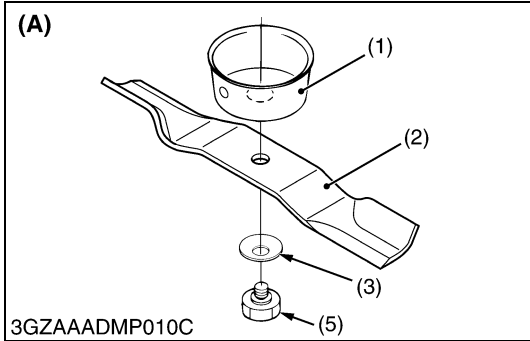

Tightening torque	Mower blade screw	103 to 117 N·m 10.5 to 12.0 kgf·m 76.0 to 86.7 lbf·ft
-------------------	-------------------	---

- (1) Dust Cover
 (2) Mower Blade
 (3) Cup Washer
 (4) Lock Washer
 (5) Mower Blade Screw

- (A) RCK48-18BX, RCK54-23BX,
 RCK48P-18BX, RCK54P-23BX
 (B) RCK60B-23BX
 a : Loosen

W1012667

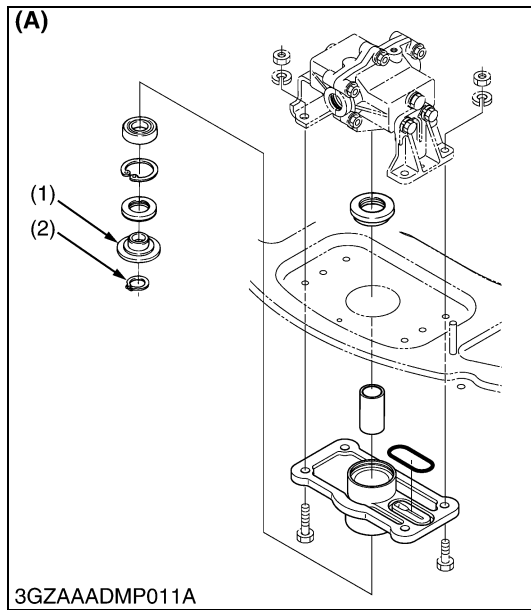

Blade Boss

1. Remove the external snap ring (2).
2. Remove the blade boss (1).

- (1) Blade Boss
- (2) External Snap Ring

- (A) RCK48P-18BX, RCK54P-23BX
- (B) RCK48-18BX, RCK54-23BX, RCK60B-23BX

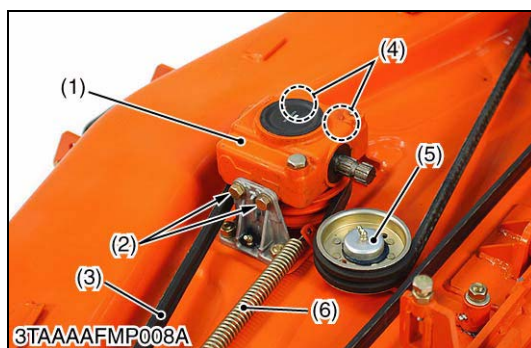
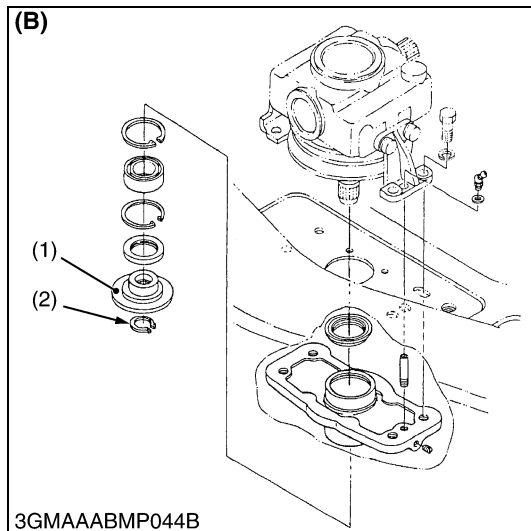

Gear Box and Mower Belt

1. Turn over the mower.
2. Remove the mower belt (3) from the tension pulley (5).
3. Unscrew the left and right gear box mounting screws (2), (4) and remove the gear box (1) from the mower deck.

(When reassembling)

- Install the reamer screw (2) at their original positions as shown in the figure.

Tightening torque	Gear box mounting screw and nut	78 to 90 N·m 7.9 to 9.2 kgf·m 58 to 66 lbf·ft
-------------------	---------------------------------	---

- (1) Gear Box
- (2) Gear Box Mounting Screw (Reamer Screw)
- (3) Mower Belt
- (4) Gear Box Mounting Screw
- (5) Tension Pulley
- (6) Tension Spring

W1012961

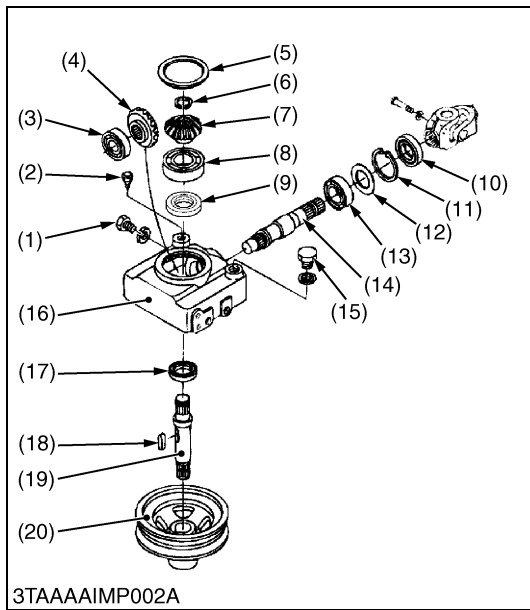

Disassembling Gear Box [RCK54-23BX, RCK60B-23BX]

1. Unscrew the drain plug (1), and drain the gear box oil.
2. Remove the center pulley (20) with a puller, and remove the feather key (18) on the bevel gear shaft (19).
3. Remove the gear box cap (5).
4. Remove the oil seal (10), internal snap ring (11) and shim (12).
5. Tap out the pinion shaft (14) with the ball bearing (13), and remove the bevel gear (1).
6. Remove the ball bearing (3) and shims (if installed).
7. Remove the external snap ring (6), and draw out the bevel gear shaft (19).
8. Remove the bevel gear (7), ball bearing (8), shim (9) and oil seal (17).

(When reassembling)

- Replace the oil seals (10), (17) and gear box cap (8) with new ones.
- Check the backlash and turning torque.
If not proper, adjust with the shims.
(See page 7-S10.)

- | | |
|----------------------------------|-------------------------|
| (1) 19T Bevel Gear (RCK54-23BX) | (12) Shim |
| 18T Bevel Gear (RCK60B-23BX) | (13) Oil Seal |
| (2) Breather | (14) Internal Snap Ring |
| (3) Gear Box | (15) Shim |
| (4) Ball Bearing | (16) Ball Bearing |
| (5) Shim | (17) Pinion Shaft |
| (6) Internal Snap Ring | (18) Oil Filler Plug |
| (7) Gear Box Cap | (19) Drain Plug |
| (8) Gear Box Cap | (20) Oil Seal |
| (9) External Snap Ring | (21) Bevel Gear Shaft |
| (10) 16T Bevel Gear (RCK54-23BX) | (22) Feather Key |
| 17T Bevel Gear (RCK60B-23BX) | (23) Center Pulley |
| (11) Ball Bearing | |

W1018143

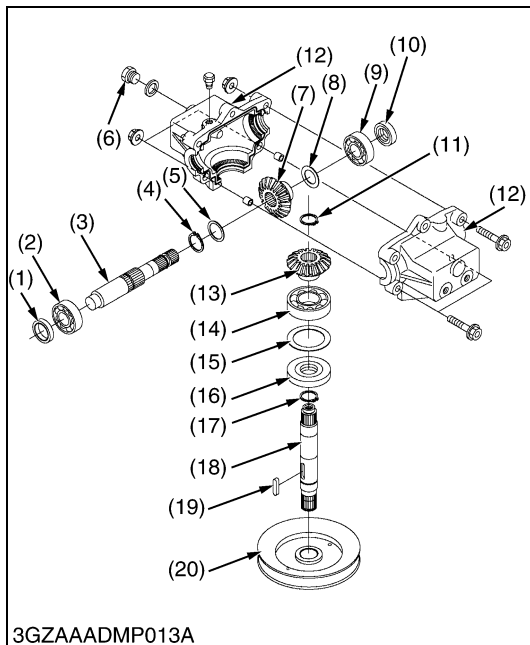

Disassembling Gear Box (RCK54P-23BX)

1. Unscrew the drain plug (6), and drain the gear box oil.
2. Remove the center pulley (20) with a puller.
3. Remove the gear box.
4. Open the gear box.
5. Remove the input shaft (3) and the blade shaft (18).
6. Disassembling the input shaft (3) and the blade shaft (18).

(When reassembling)

- Replace the oil seals (1), (10), (16) and gear box caps with new ones.
- Check the backlash and turning torque.
If not proper, adjust with the shims.
- After cleaning dirty and gear box oil and the gear box surface, apply the liquid gasket.

Tightening torque	Gear box screw	24 to 27 N·m 2.4 to 2.8 kgf·m 17 to 20 lbf·ft
-------------------	----------------	---

- | | |
|-----------------------|------------------------|
| (1) Oil Seal | (11) External Cir Clip |
| (2) Ball Bearing | (12) Bevel Gear Case |
| (3) Input Shaft | (13) Bevel Gear |
| (4) External Cir Clip | (14) Ball Bearing |
| (5) Shim | (15) Shim |
| (6) Drain Plug | (16) Oil Seal |
| (7) Bevel Gear | (17) External Cir Clip |
| (8) Shim | (18) Blade Shaft |
| (9) Ball Bearing | (19) Feather Key |
| (10) Oil Seal | (20) Center Pulley |

W1015954

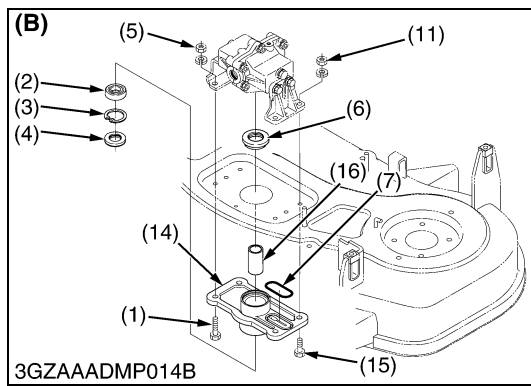
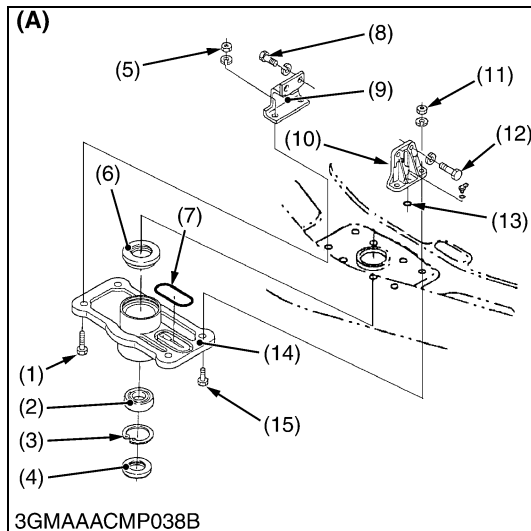

Center Pulley Holder

1. Unscrew the center pulley holder screws (1), (15) / center pulley nut (5), (11).
2. Remove the upper oil seal (6) and lower oil seal (4).
3. Remove the internal snap ring (3) and ball bearing (2).

(When reassembling)

- Replace the oil seals (4), (6) with new ones.
- Install the reamer screws (12) / reamer bolt (15) at their original positions as shown in the figure.
- Be sure to fix the O-rings (7), (13) to the original position.

NOTE

- **When reassembling the center pulley holder (14), gear box and gear box stays (9), (10), tighten the bolts and nuts in the order as below, to prevent the incline the gear box.**
- **Tighten the reamer bolts (12) to the gear box first, then tighten the reamer bolts (15) and nut (11) to the center pulley holder (14) with specified torque.**
- **Tighten the gear box screws (8) to the gear box, then tighten the center pulley holder bolts (1) and nut (5) with specified torque.**
- **See page 7-S6 for tightening torque of gear box screw.**

Tightening torque	Center pulley holder bolt and nut	78 to 90 N·m 7.9 to 9.2 kgf·m 58 to 66 lbf·ft
-------------------	-----------------------------------	---

- | | |
|--|--|
| <ul style="list-style-type: none"> (1) Center Pulley Holder bolt (2) Ball Bearing (3) Snap Ring (4) Oil Seal (5) Nut (6) Oil Seal (7) O-ring (8) O-ring (9) Gear Box Stay RH (10) Gear Box Stay LH | <ul style="list-style-type: none"> (11) Nut (12) Gear Box Reamer Bolt (13) O-ring (14) Center Pulley Holder (15) Center Pulley Holder Reamer Bolt (16) Collar <p style="text-align: center;">(A)RCK48-18BX, RCK54-23BX,
RCK60B-23BX
(B) RCK48P-18BX, RCK54P-23BX</p> |
|--|--|

W1013720

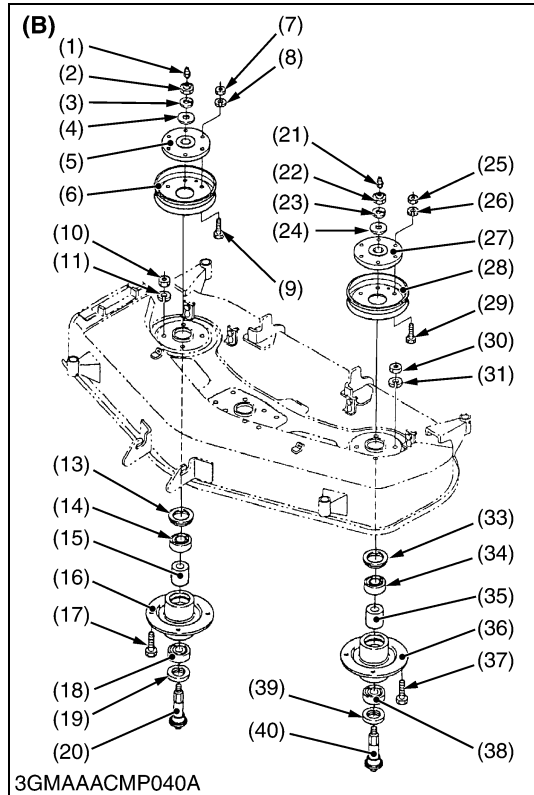
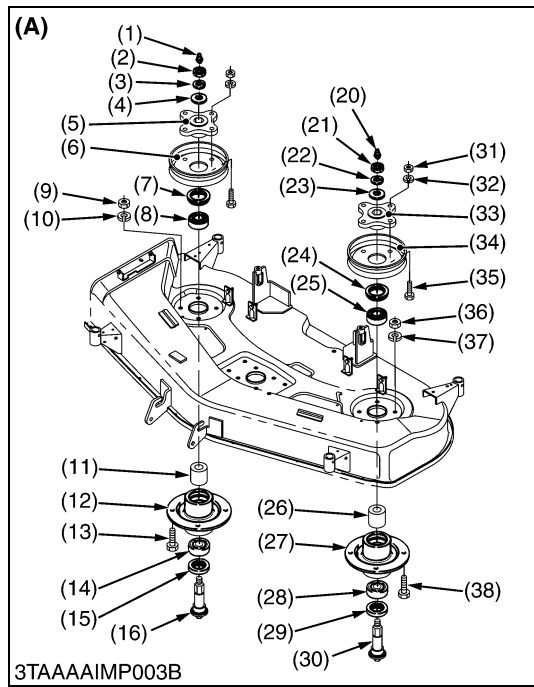

Outer Pulley and Blade Shaft

1. Unscrew the outer pulley mounting nuts (21), and remove the outer pulley (34).
2. Unscrew the pulley holder mounting nuts (36), and remove the left pulley holder (27).
3. Remove the oil seal (29) and tap out the left blade shaft (30) with the ball bearings (28), (25), taking care not to damage the grease nipple (20).
4. Remove the oil seal (24).
5. Remove the ball bearings (28), (25) and collar (26) from the blade shaft (30).
6. Remove the right pulley holder (12) and blade shaft (16) as above.

(When reassembling)

- Replace the oil seals (33), (39), (13) and (19) with new ones.

Tightening torque	Outer pulley mounting nut	197 to 225 N·m 20.0 to 23.0 kgf·m 145 to 166 lbf·ft
	Pulley boss mounting nut	24 to 27 N·m 2.4 to 2.8 kgf·m 18 to 20 lbf·ft
	Pulley holder mounting bolt and nut (RCK48-18BX)	48.0 to 55.9 N·m 4.9 to 5.7 kgf·m 35.4 to 41.2 lbf·ft
	Pulley holder mounting bolt and nut (RCK54-23BX, RCK60B-23BX)	78 to 90 N·m 7.9 to 9.2 kgf·m 58 to 66 lbf·ft

- | | |
|--|---|
| <ul style="list-style-type: none"> (1) Grease Nipple (2) Outer Pulley Mounting Nut (3) Spring Washer (4) Plain Washer (5) Outer Pulley Boss (Right) (6) Outer Pulley (Right) (7) Oil Seal (8) Ball Bearing (9) Pulley Holder Mounting Nut (10) Spring Washer (11) Collar (12) Pulley Holder (Right) (13) Pulley Holder Mounting Bolt (14) Ball Bearing (15) Oil Seal (16) Blade Shaft (Right) (17) Pulley Holder Mounting Nut (18) Spring Washer (19) Pulley Boss Mounting Bolt (20) Grease Nipple (21) Outer Pulley Mounting Nut | <ul style="list-style-type: none"> (22) Spring Washer (23) Plain Washer (24) Oil Seal (25) Ball Bearing (26) Collar (27) Pulley Holder (Left) (28) Ball Bearing (29) Oil Seal (30) Blade Shaft (Left) (31) Pulley Boss Mounting Nut (32) Spring Washer (33) Outer Pulley Boss (Left) (34) Outer Pulley (Left) (35) Pulley Boss Mounting Bolt (36) Pulley Holder Mounting Nut (37) Spring Washer (38) Pulley Holder Mounting Bolt |
|--|---|
- (A) RCK48-18BX**
(B) RCK54-23BX, RCK60B-22BX

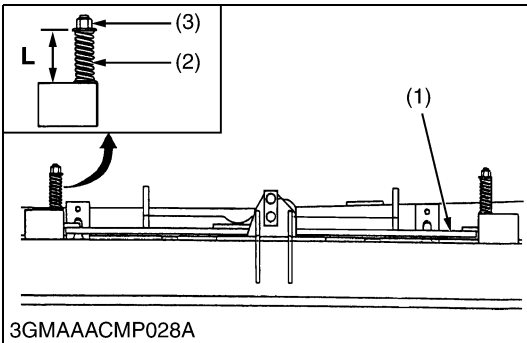
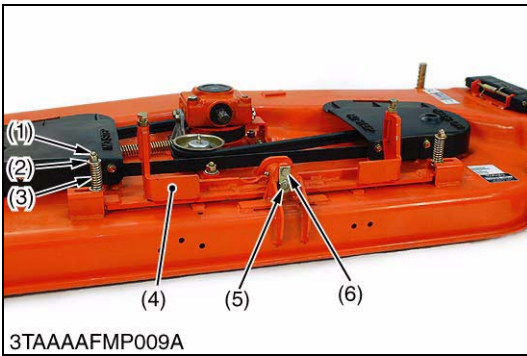

Balancer

1. Unscrew the lock nut (1) both side.
2. Remove the plain washer (2) and balancer spring (3).
3. Unscrew the center pin bolt (6).
4. Remove the center pin (5) and balancer plate (4).

(When reassembling)

- Apply grease to the center pin (5).
- Adjust the balancer spring (3) length to the factory specification, with lock nut (1).

Balancer spring length (L) (Right and left)	Factory spec.	55.0 mm 2.17 in.
---	---------------	---------------------

- | | |
|---------------------|---------------------|
| (1) Lock Nut | (4) Balancer Plate |
| (2) Plain Washer | (5) Center Pin |
| (3) Balancer Spring | (6) Center Pin Bolt |

W1017924

[3] SERVICING

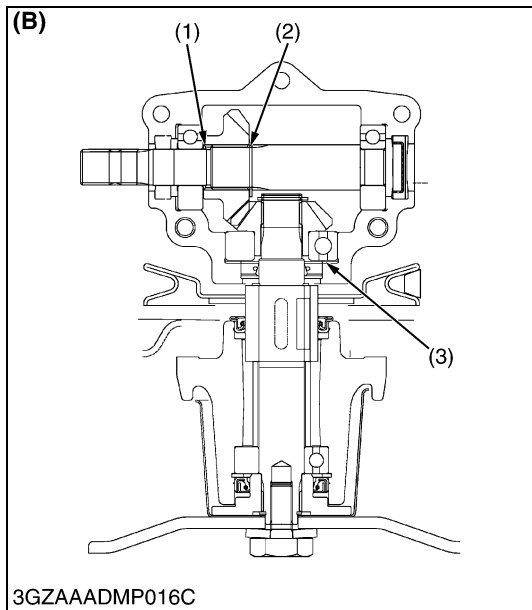
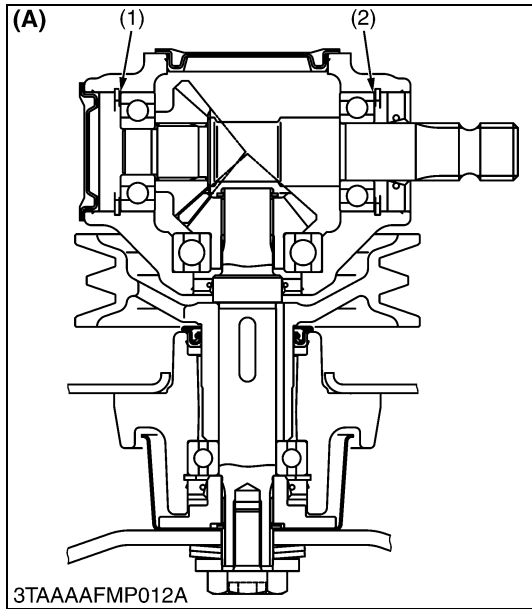

Turning Torque of Pinion Shaft

1. Remove the mower belt, and reassemble the gear box to the mower deck.
2. Wind a string around the pinion shaft and set a spring balance (or push-pull gauge) to the tip of the string, and then slowly pull the spring balance horizontally to measure the turning force.
3. If the measurement exceeds the factory specification, check the bearing and gears and adjust the adjusting shims (1), (2), (3).

[RCK48-18BX, RCK54-23BX and RCK60B-23BX]

Turning force	Factory spec.	Less than 118 N 12.0 kgf 26.5 lbf
---------------	---------------	---

Turning torque	Factory spec.	Less than 1.5 N·m 0.15 kgf·m 1.1 lbf·ft
----------------	---------------	---

(Reference)

- Thickness of adjusting shims (1), (2) : 0.2 mm (0.0079 in.)
0.3 mm (0.0118 in.)
- Thickness of adjusting shims (3) : 0.1 mm (0.0039 in.)
0.2 mm (0.0079 in.)

[RCK48P-18BX and RCK54P-23BX]

Turning force	Factory spec.	Less than 0.7 N·m 0.07 kgf·m 0.52 lbf·ft
---------------	---------------	--

(Reference)

- Thickness of adjusting shims (1), (2) : 0.2 mm (0.0079 in.)
0.3 mm (0.0118 in.)
- Thickness of adjusting shims (3) : 0.2 mm (0.0079 in.)
0.3 mm (0.0118 in.)

- (1) Adjusting Shim
- (2) Adjusting Shim
- (3) Adjusting Shim

- (A) RCK48-18BX, RCK54-23BX and RCK60B-23BX
- (B) RCK48P-18BX and RCK54P-23BX

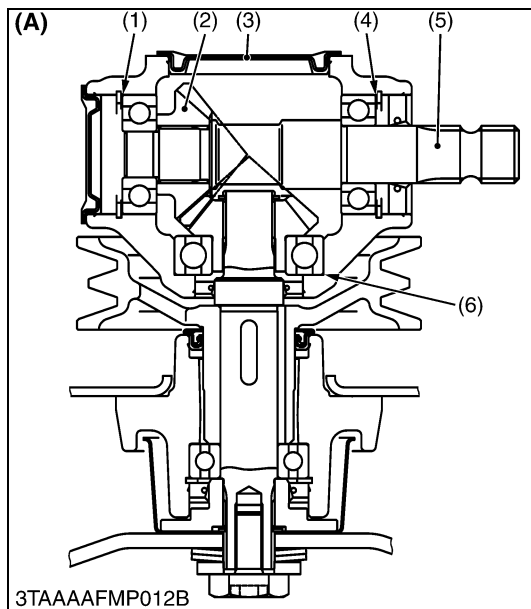

Backlash between Bevel Gears

1. Remove the gear box cap (3).
2. Place fuses the bevel gear (2) on the input shaft (5).
3. Turn the input shaft (5).
4. Take out the fuses, and measure the thickness of fuses with an outside micrometer. (Backlash equal thickness of fuse)
5. If the backlash exceeds the allowable limit, adjust with shims (1), (4), (6).

[RCK48-18BX, RCK54-23BX and RCK60B-23BX]

Backlash between bevel gears	Factory spec.	0.10 to 0.20 mm 0.0039 to 0.0079 in.
	Allowable limit	0.4 mm 0.0157 in.

(Reference)

- Thickness of adjusting shims (1), (4) : 0.2 mm (0.0079 in.)
0.3 mm (0.0118 in.)
- Thickness of adjusting shims (6) : 0.1 mm (0.0039 in.)
0.2 mm (0.0079 in.)

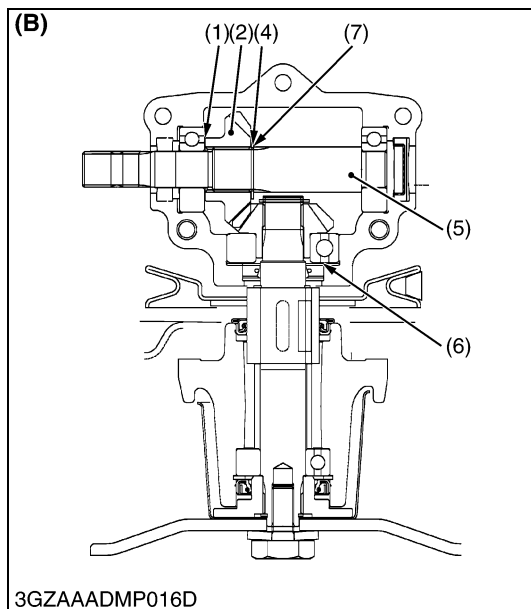

[RCK48P-18BX and RCK54P-23BX]

Backlash between bevel gears	Factory spec.	0.13 to 0.25 mm 0.0051 to 0.0098 in.
	Allowable limit	0.40 mm 0.0157 in.

(Reference)

- Thickness of adjusting shims (1), (4) : 0.2 mm (0.0079 in.)
0.3 mm (0.0118 in.)
- Thickness of adjusting shims (6) : 0.2 mm (0.0079 in.)
0.3 mm (0.0118 in.)

- | | |
|---|-----------------------|
| (1) Shim | (3) Gear Box Cap |
| (2) 21T Bevel Gear
(RCK48-18BX, RCK48P-18BX) | (4) Shim |
| 19T Bevel Gear
(RCK54-23BX, RCK54P-23BX) | (5) Input Shaft |
| 18T Bevel Gear
(RCK60B-23BX) | (6) Shim |
| | (7) External Cir Clip |

(A) RCK48-18BX, RCK54-23BX and RCK60B-23BX

(B) RCK48P-18BX and RCK54P-23BX

W1020126

8 FRONT LOADER

SAFETY DECALS

The following safety decals are installed on the machine.

If a decal becomes damaged, illegible or is not on the machine, replace it. The decal part number is listed in the parts list.

(1) Part No. 7J246-5643-1

⚠ DANGER



TO AVOID SERIOUS INJURY OR DEATH CAUSED BY FALLING LOADS :

1. Load on raised bucket or fork can fall or roll back onto operator causing serious injury or death.
2. Use approved clamping and / or guard attachments for handling large, loose or shiftable loads such as bales, posts, sheets of plywood etc.
3. Carry loads as low as possible.

1AIABAHAP016A

(2) Part No. 7J246-5645-1

⚠ CAUTION

TO AVOID PERSONAL INJURY :

1. Observe safety precautions in loader and tractor Operator's Manual.
2. Operate the loader from tractor seat only.
3. Keep children, others and livestock away when operating loader and tractor.
4. Avoid holes, loose ground, and rocks which may cause tractor / loader to tip.
5. Make sure approved bucket is attached before removing loader from tractor.
6. When parking or storing, choose flat and hard ground. Lower the bucket to the ground, set brakes and remove key before leaving tractor.
7. Before disconnecting hydraulic lines, relieve all hydraulic pressure.

1AIABAHAP019A

(3) Part No. 7J246-5642-1

⚠ DANGER

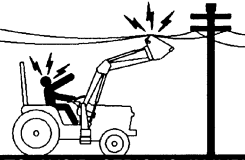

TO AVOID SERIOUS INJURY OR DEATH CAUSED BY CONTACT WITH ELECTRIC LINES:

- Check overhead clearance.

1AIABAHAP018A

(5) Part No. 7J246-5644-2
(Both sides)

⚠ WARNING



TO AVOID INJURY FROM FALLS OR BEING CRUSHED :

1. DO NOT stand or work under raised loader or bucket.
2. DO NOT use loader as jack for servicing.
3. DO NOT use loader as a work platform.
4. NEVER connect chain, cable or rope to loader bucket while operating loader.

1AIABAHAP020A

(4) Part No. 7J266-5649-2

⚠ CAUTION

TO AVOID INJURY FROM CRUSHING :

1. Do not utilize the valve lock for machine maintenance or repair.
2. The valve lock is to prevent accidental actuation when implement is not in use or during transport.

1AIABACAP077A

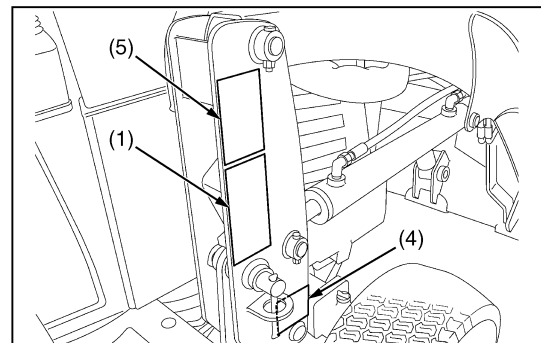
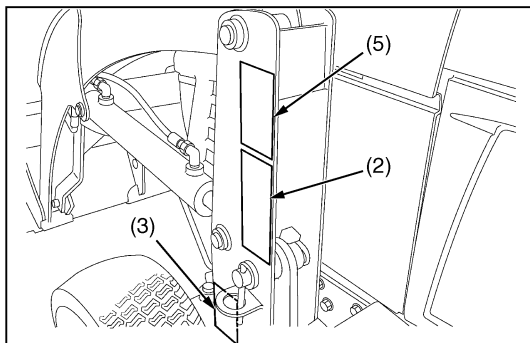

3TAAAAICP002A

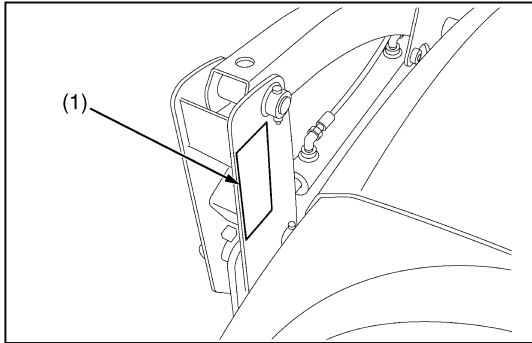

(1) Part No. 7J246-5641-1



1A1ABAHAP017A

CARE OF DANGER, WARNING AND CAUTION LABELS

1. Keep danger, warning and caution labels clean and free from obstructing material.
2. Clean danger, warning and caution labels with soap and water, dry with a soft cloth.
3. Replace damaged or missing danger, warning and caution labels with new labels.
4. If a component with danger, warning or caution label(s) affixed is replaced with new part, make sure new label(s) is (are) attached in the same locations(s) as the replaced component.
5. Mount new danger, warning and caution labels by applying on a clean dry surface and pressing any bubbles to outside edge.

3TAAAAICP003A

SPECIFICATIONS

■ Loader Specifications

Loader model		LA203	LA243
Tractor model		BX1860	BX2360, BX2660
Wheel base (WB)		1340 mm (52.8 in.)	1400 mm (55.1 in.)
Front tires		16 x 7.5-8	18 x 8.5-10
Rear tires		24 x 12-12	26 x 12-12
Boom cylinder	Bore	40 mm (1.57 in.)	
	Stroke	281 mm (11.1 in.)	326 mm (12.8 in.)
Bucket cylinder	Bore	65 mm (2.56 in.)	
	Stroke	204 mm (8.03 in.)	
Control valve		One detente float position, two stage bucket dump, power beyond circuit	
Rated flow		14 L/min. (3.7 U.S.gals/min., 3.1 Imp.gals/min.)	
Maximum pressure		12.3 MPa (125 kgf/cm ² , 1778 psi)	
Net weight (Approximate)		157 kg (346 lbs)	170 kg (375 lbs)

W1027852

■ Bucket Specifications

Loader model		LA203	LA243
Model		Square 48"	
Type		Rigid	
Width		1219 mm (48.0 in.)	
Depth (L)		455 mm (17.9 in.)	495 mm (19.5 in.)
Height (M)		445 mm (17.5 in.)	465 mm (18.3 in.)
Length (N)		498 mm (19.6 in.)	538 mm (21.2 in.)
Capacity	Struck	0.12 m ³ (4.2 CU.FT.)	0.14 m ³ (4.9 CU.FT.)
	Heaped	0.14 m ³ (4.9 CU.FT.)	0.17 m ³ (6.1 CU.FT.)
Weight		56 kg (123 lbs)	60 kg (132 lbs)

W1030245

■ Dimensional Specifications

Loader Model		LA203	LA243
	Tractor model	BX1860	BX2350, BX2660
A	Max. lift height (To bucket pivot pin)	1810 mm (71.3 in.)	
B	Max. lift height under level bucket	1680 mm (66.1 in.)	
C	Clearance with bucket dumped	1350 mm (53.1 in.)	1330 mm (52.4 in.)
D	Reach at max. lift height (Dumping reach)	720 mm (28.3 in.)	735 mm (28.9 in.)
E	Max. dump angle	40 deg. (0.784 rad)	45 deg. (0.785 rad)
F	Reach with bucket on ground	1330 mm (52.4 in.)	1390 mm (54.7 in.)
G	Bucket roll-back angle	30 deg. (0.59 rad)	29 deg. (0.51 rad)
H	Digging depth	100 mm (3.9 in.)	120 mm (4.7 in.)
I	Overall height in carrying position	970 mm (38.2 in.)	990 mm (39.0 in.)

W1028417

Operational Specifications

Loader Model		LA203	LA243
Tractor model		BX1860	BX2350, BX2660
Lift capacity to max. height (Bucket bottom mid point)		200 kg (441 lbs)	240 kg (529 lbs)
U	Lift capacity (Bucket pivot pin, max. height)	280 kg (617 lbs)	340 kg (750 lbs)
V	Lift capacity (500 mm forward, max. height)	185 kg (408 lbs)	235 kg (518 lbs)
W	Lift capacity (Bucket pivot pin, 1500 mm (59 in.) height)	315 kg (694 lbs)	375 kg (827 lbs)
X	Lift capacity (1500 mm height)	220 kg (485 lbs)	270 kg (595 lbs)
Y	Breakout force (Bucket pivot pin)	5720 N (1287 lbs)	6290 N (1415 lbs)
Z	Breakout force (500 mm forward)	3920 N (882 lbs)	4410 N (992 lbs)
VV	Bucket roll-back force at max. height	4460 N (1003 lbs)	4750 N (1069 lbs)
XX	Bucket roll-back force at 1.5M (5.9 in.)	5380 N (1210 lbs)	5600 N (1260 lbs)
ZZ	Bucket roll-back force at ground level	5580 N (1255 lbs)	5490 N (1235 lbs)
Raising time		2.8 sec.	3.5 sec.
Lowering time		2.0 sec.	2.7 sec.
Bucket dumping time		1.8 sec.	1.7 sec.
Bucket rollback time		2.1 sec.	2.4 sec.

W1030633

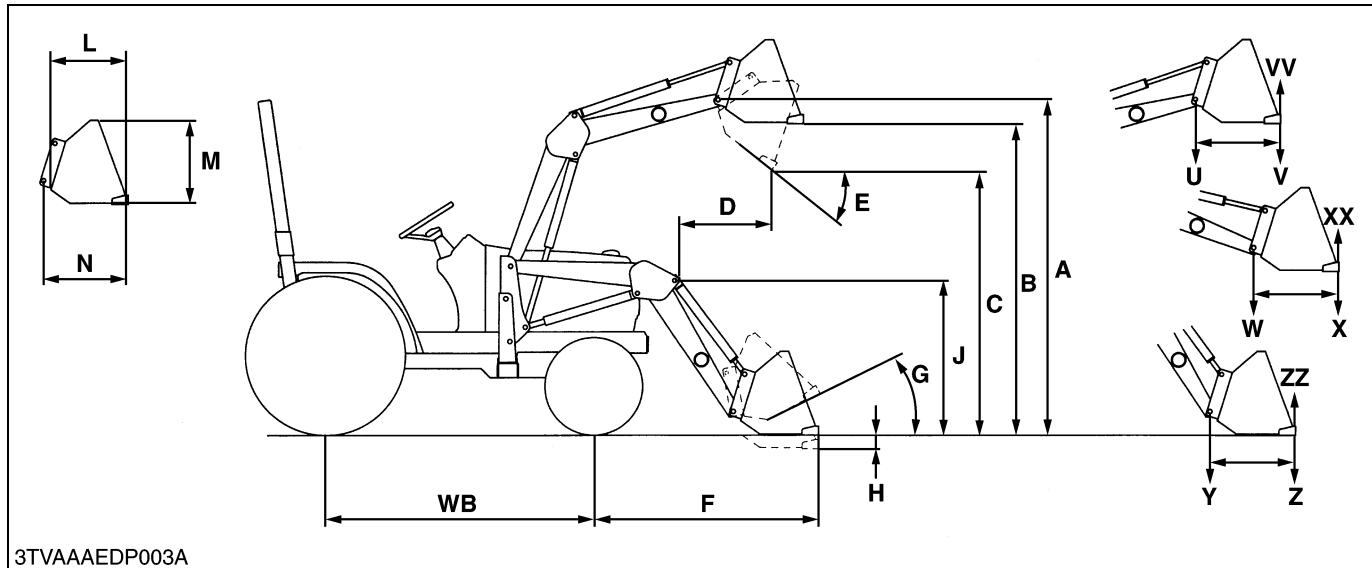

GENERAL

CONTENTS

1. IDENTIFICATION.....	8-G1
2. GENERAL PRECAUTION	8-G2
3. LUBRICANTS	8-G3
4. TIGHTENING TORQUES	8-G4
[1] GENERAL USE SCREWS, BOLTS AND NUTS (FOR FRONT LOADER AND BACKHOE).....	8-G4
[2] STUD BOLTS.....	8-G4
[3] AMERICAN STANDARD SCREWS, BOLTS AND NUTS WITH UNC OR UNF THREADS	8-G5
[4] PLUGS.....	8-G5
[5] HYDRAULIC FITTINGS.....	8-G6
[6] TIGHTENING TORQUES OF SCREWS, BOLTS AND NUTS ON THE TABLE BELOW ARE ESPECIALLY SPECIFIED	8-G6
5. MAINTENANCE CHECK LIST.....	8-G7
6. CHECK AND MAINTENANCE.....	8-G8
[1] CHECK POINTS OF EACH USE OR DAILY.....	8-G8
[2] CHECK POINTS OF EVERY 10 HOURS.....	8-G8
7. DISMOUNTING AND MOUNTING FRONT LOADER FROM TRACTOR	8-G9
[1] DISMOUNTING FRONT LOADER FROM TRACTOR	8-G9
[2] MOUNTING FRONT LOADER TO TRACTOR.....	8-G10

1. IDENTIFICATION

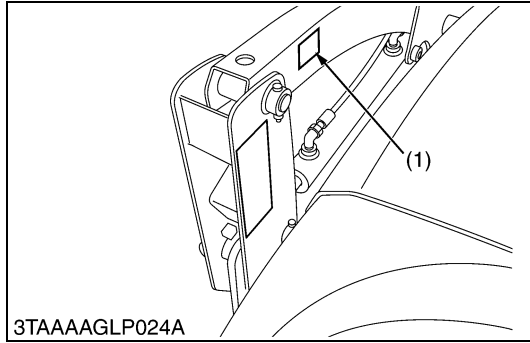

When contacting your local KUBOTA distributor, always specify front loader model and serial number.

(1) Model / Serial Number

W1010468

2. GENERAL PRECAUTION

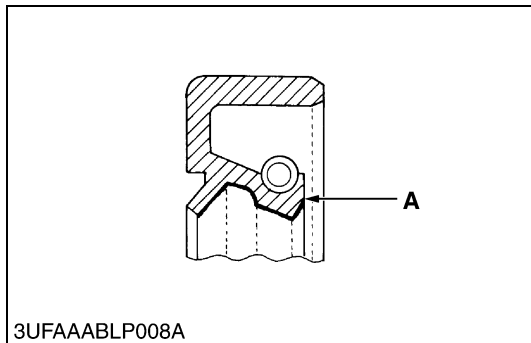

- During disassembly, carefully arrange removed parts in a clean area to prevent later confusion. Screws, bolts and nuts should be replaced in their original positions to prevent reassembly errors.
- When special tools are required, use genuine KUBOTA tools. Special tools which are not used frequently should be made according to the drawings provided.
- Clean parts before measuring them.
- Use only genuine KUBOTA parts for parts replacement to maintain loader performance and to assure safety.
- O-ring and oil seals must be replaced during reassembly. Apply grease to new O-rings or oil seals before reassembling.

A : Grease

W1010531

3. LUBRICANTS

To prevent serious damage to hydraulic system, use only specified fluid or its equivalent.

Place	Capacities	Lubricants
Transmission Case	11.6 L 3.1 U.S.gals 2.6 Imp.gals	KUBOTA SUPER UDT Fluid *
Grease fitting	Until grease overflows	Moly Ep Type grease

■ **NOTE**







- * **KUBOTA SUPER UDT Fluid**.....KUBOTA original transmission hydraulic fluid

W1010650

4. TIGHTENING TORQUES

[1] GENERAL USE SCREWS, BOLTS AND NUTS (FOR FRONT LOADER AND BACKHOE)

Screws, bolts, and nuts whose tightening torques are not specified in this Workshop Manual should be tightened according to the table below.

Indication on top of bolt	  No-grade or 4T						  7T or Property class 8.8						  9T or Property class 10.9			
	Material of opponent part	Ordinariness			Aluminum			Ordinariness			Aluminum			Ordinariness		
Diameter	Unit	N·m	kgf·m	lbf·ft	N·m	kgf·m	lbf·ft	N·m	kgf·m	lbf·ft	N·m	kgf·m	lbf·ft	N·m	kgf·m	lbf·ft
M6 (6 mm, 0.24 in.)		7.9	0.80	5.8	7.9	0.80	5.8	9.81	1.00	7.24	7.9	0.80	5.8	12.3	1.25	9.05
		to 9.3	to 0.95	to 6.8	to 8.8	to 0.90	to 6.5	to 11.2	to 1.15	to 8.31	to 8.8	to 0.90	to 6.5	to 14.2	to 1.45	to 10.4
M8 (8 mm, 0.31 in.)		18	1.8	13	17	1.7	13	24	2.4	18	18	1.8	13	30	3.0	22
		to 20	to 2.1	to 15	to 19	to 2.0	to 14	to 27	to 2.8	to 20	to 20	to 2.1	to 15	to 34	to 3.5	to 25
M10 (10 mm, 0.39 in.)		40	4.0	29	32	3.2	24	48	4.9	36	40	4.0	29	61	6.2	45
		to 45	to 4.6	to 33	to 34	to 3.5	to 25	to 55	to 5.7	to 41	to 44	to 4.5	to 32	to 70	to 7.2	to 52
M12 (12 mm, 0.47 in.)		63	6.4	47	-	-	-	78	7.9	58	63	6.4	47	103	10.5	76.0
		to 72	to 7.4	to 53	-	-	-	to 90	to 9.2	to 66	to 72	to 7.4	to 53	to 117	to 12.0	to 86.7
M14 (14 mm, 0.55 in.)		108	11.0	79.6	-	-	-	124	12.6	91.2	-	-	-	167	17.0	123
		to 125	to 12.8	to 92.5	-	-	-	to 147	to 15.0	to 108	-	-	-	to 196	to 20.0	to 144
M16 (16 mm, 0.63 in.)		167	17.0	123	-	-	-	197	20.0	145	-	-	-	260	26.5	192
		to 191	to 19.5	to 141	-	-	-	to 225	to 23.0	to 166	-	-	-	to 304	to 31.0	to 224
M18 (18 mm, 0.71 in.)		246	25.0	181	-	-	-	275	28.0	203	-	-	-	344	35.0	254
		to 284	to 29.0	to 209	-	-	-	to 318	to 32.5	to 235	-	-	-	to 402	to 41.0	to 296
M20 (20 mm, 0.79 in.)		334	34.0	246	-	-	-	368	37.5	272	-	-	-	491	50.0	362
		to 392	to 40.0	to 289	-	-	-	to 431	to 44.0	to 318	-	-	-	to 568	to 58.0	to 419



W1034542

[2] STUD BOLTS

Material of opponent part	Ordinariness			Aluminum			
Diameter	Unit	N·m	kgf·m	lbf·ft	N·m	kgf·m	lbf·ft
M8 (8 mm, 0.31 in.)		12	1.2	8.7	8.9	0.9	6.5
		to 15	to 1.6	to 11	to 11	to 1.2	to 8.6
M10 (10 mm, 0.39 in.)		25	2.5	18	20	2.0	15
		to 31	to 3.2	to 23	to 25	to 2.6	to 18
M12 (12 mm, 0.47 in.)		29.5	3.0	21.7	-	-	-
		to 49.0	to 5.0	to 36.1	31.4	3.2	23.1
M14 (14 mm, 0.55 in.)		62	6.3	46	-	-	-
		to 73	to 7.5	to 54	-	-	-
M16 (16 mm, 0.63 in.)		98.1	10.0	72.4	-	-	-
		to 112	to 11.5	to 83.1	-	-	-
M18 (18 mm, 0.71 in.)		172	17.5	127	-	-	-
		to 201	to 20.5	to 148	-	-	-



W1048139

[3] AMERICAN STANDARD SCREWS, BOLTS AND NUTS WITH UNC OR UNF THREADS

Grade	SAE GR.5 			SAE GR.8 			
	Unit	N-m	kgf-m	lbf-ft	N-m	kgf-m	lbf-ft
Nominal Diameter							
1/4	11.7 to 15.7	1.19 to 1.61	8.61 to 11.6	16.3 to 19.7	1.66 to 2.01	12.0 to 14.6	
5/16	23.1 to 27.7	2.35 to 2.83	17.0 to 20.5	33 to 39	3.4 to 4.0	24 to 29	
3/8	48 to 56	4.9 to 5.8	35.0 to 42.0	61 to 73	6.3 to 7.4	45 to 54	
1/2	110 to 130	11 to 13	80 to 96	150 to 178	15.2 to 18.2	110 to 132	
9/16	150 to 178	15.2 to 18.2	110 to 132	217 to 260	22.2 to 26.5	160 to 192	
5/8	204 to 244	20.8 to 24.8	150 to 180	299 to 357	30.5 to 36.4	220 to 264	

W1022485

[4] PLUGS

Shape	Size	Material of opponent part					
		Ordinariness			Aluminum		
		N-m	kgf-m	lbf-ft	N-m	kgf-m	lbf-ft
Tapered screw 	R1/8	13 to 21	1.3 to 2.2	9.4 to 15	13 to 21	1.3 to 2.0	9.4 to 15
	R1/4	25 to 44	2.5 to 4.5	18 to 32	25 to 34	2.5 to 3.5	18 to 25
	R3/8	49 to 88	5.0 to 9.0	37 to 65	49 to 58	5.0 to 6.0	37 to 43
	R1/2	58.9 to 107	6.00 to 11.0	43.4 to 79.5	59 to 78	6.0 to 8.0	44 to 57
Straight screw 	G1/4	25 to 34	2.5 to 3.5	18 to 25	-	-	-
	G3/8	62 to 82	6.3 to 8.4	46 to 60	-	-	-
	G1/2	49 to 88	5.0 to 9.0	37 to 65	-	-	-

000001666E

[5] HYDRAULIC FITTINGS

■ Adaptors, Elbows and Others

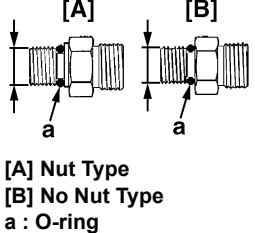
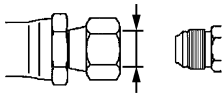
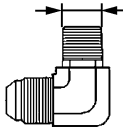
Item	Shape	Thread size	Tightening torque		
			N·m	kgf·m	lbf·ft
Adjustable elbow, Adaptor (O-ring port) (UNF)	 <p>[A] Nut Type [B] No Nut Type a : O-ring</p>	9/16	37 to 44	3.8 to 4.5	27 to 33
		3/4	48 to 54	4.9 to 5.5	35 to 40
		7/8	77 to 85	7.9 to 8.6	57 to 62
Hose fitting, Flare nut (UNF)		9/16	22 to 25	2.3 to 2.6	16 to 19
		3/4	36 to 40	3.6 to 4.1	26 to 30
		7/8	43 to 50	4.4 to 5.0	32 to 36
Adaptor (NPT)		1/4	30 to 50	3.1 to 5.0	23 to 36
		3/8	39 to 60	4.0 to 6.1	29 to 44
		1/2	49 to 58	5.0 to 5.9	36 to 43

■ NOTE

- When connecting a hose with flare nut, after tightening the nut with specified torque, return it approximately 45 degrees (0.79 rad) and re-tighten it to specified torque.

W1015484

[6] TIGHTENING TORQUES OF SCREWS, BOLTS AND NUTS ON THE TABLE BELOW ARE ESPECIALLY SPECIFIED

Item	N·m	kgf·m	ft-lbs
Boom cylinder piston mounting nut	150 to 180	15.3 to 18.3	111 to 132
Bucket cylinder piston mounting nut	350 to 400	35.7 to 40.7	259 to 295
Main frame mounting bolt and nut (M14)	147	15.0	108

W1012736

5. MAINTENANCE CHECK LIST

To keep the machine working in good condition as well as to avoid any accident and trouble, carry out periodic inspection and maintenance. Check the following points before use.

Service Interval	Check Points	Reference Page
Daily (Each use)	Check the transmission fluid level	8-G8
	Check the hydraulic hoses	8-G8
Every 10 hours	Grease all grease fitting	8-G8
	Lubricate joints of control lever linkage	8-G8

W1010764

6. CHECK AND MAINTENANCE

CAUTION

- When checking and repairing, park the tractor on flat ground and apply the parking brake.
- When checking and repairing, lower the bucket and stop the engine.

[1] CHECK POINTS OF EACH USE OR DAILY

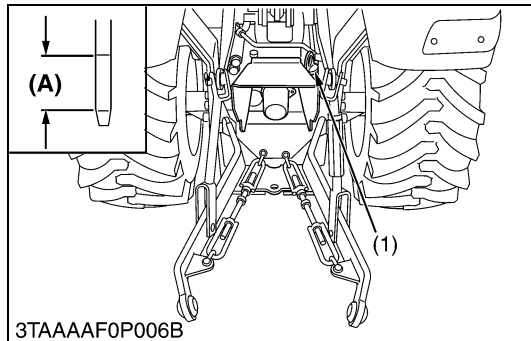

Checking Transmission Fluid Level

1. Check the oil level at the dipstick (1).
2. If the level is too low, add new oil to the prescribed level at the oil inlet.

■ IMPORTANT

- If oil level is low, do not run engine.

(1) Dipstick

A : Oil level is acceptable within this range.

W1010960

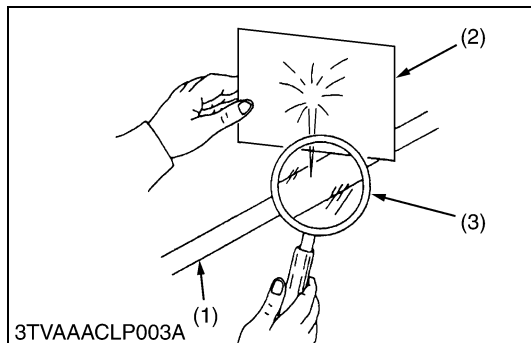

Checking Hydraulic Hoses

1. Checking all hydraulic hoses for cuts or wear.
2. If defects are found, replace them.

(1) Hydraulic Hose

(3) Magnifying Glass

(2) Cardboard

W1011064

[2] CHECK POINTS OF EVERY 10 HOURS

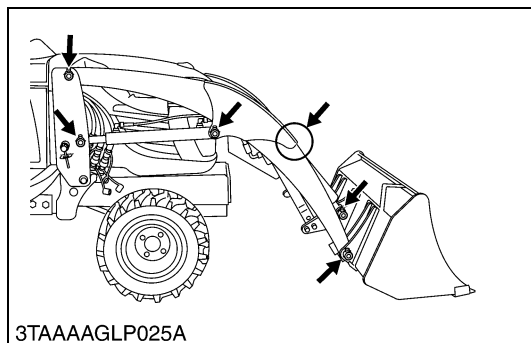

Greasing

1. Inject grease in all grease fitting with a hand grease gun.

W1011132

Lubricating

1. Lubricate joints of control lever linkage.

W1011274

7. DISMOUNTING AND MOUNTING FRONT LOADER FROM TRACTOR

■ IMPORTANT

- When dismantling the loader, park the tractor on flat and hard ground, apply the parking brake.
- When starting the engine or using the hydraulic control valve, always sit in the operator's seat.

[1] DISMOUNTING FRONT LOADER FROM TRACTOR

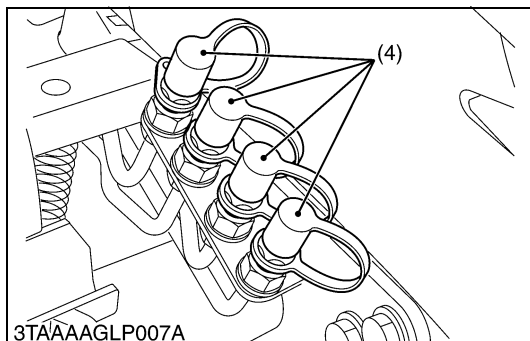
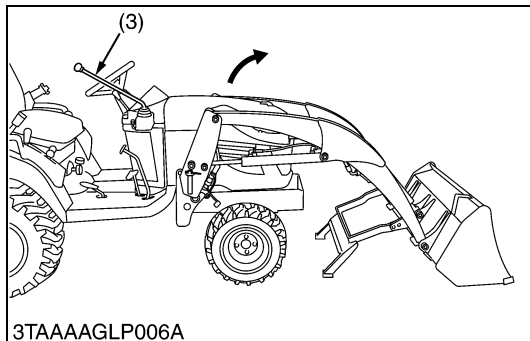
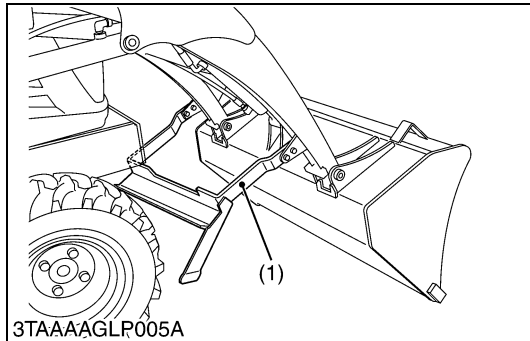
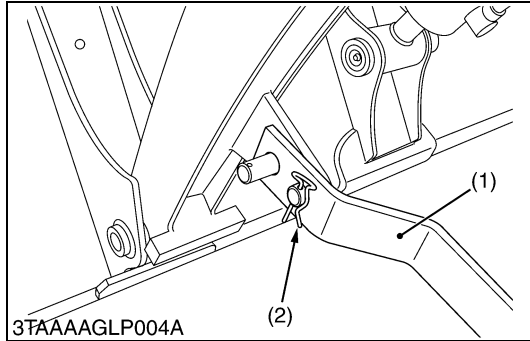

Side Frame

1. Raise the boom until the stands (1) can be rotated.
2. Stop the engine.
3. Remove the spring pin (2) holding the stand (1) to the boom.
4. Slide the stands (1) leftward and rotate it until the hole in the stand and pin on the boom are aligned. Then slide the stand (1) rightward and insert the spring pin (2) as shown.
5. Start the engine and run at idle.
6. Dump the bucket approximately 20 degrees.
7. Lower the boom and raise the front wheels slightly.

■ IMPORTANT

- **Lift the front wheels with the bucket. Do not attempt to lift the with the stand.**
8. Stop the engine.
 9. Remove the mounting pins from the loader side frames and hold them in the plate of side frame.
 10. Start the engine and run at idle. Slowly move the hydraulic control lever (3) to rollback position to raise the loader side frames up and out of the receives of the main frames as shown.
 11. Stop the engine.
 12. Slowly release all hydraulic pressure by moving the hydraulic control lever (3) in all directions.
 13. Disconnect the four hoses with quick couplers at the control valve and place them on the right side of the boom.
 14. Place the protective caps and plugs (4) on the quick coupler ends.
 15. Start the engine and slowly back the tractor away from the loader.

- (1) Stand
(2) Spring Pin

- (3) Hydraulic Control Lever
(4) Protective Plug

W1012789

[2] MOUNTING FRONT LOADER TO TRACTOR

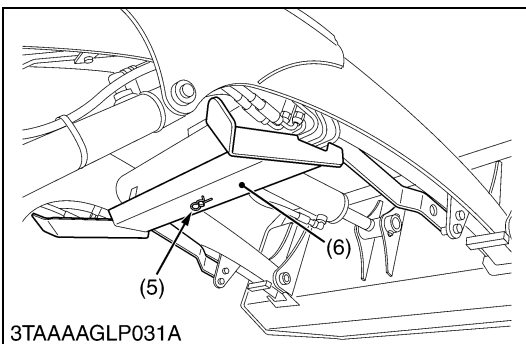
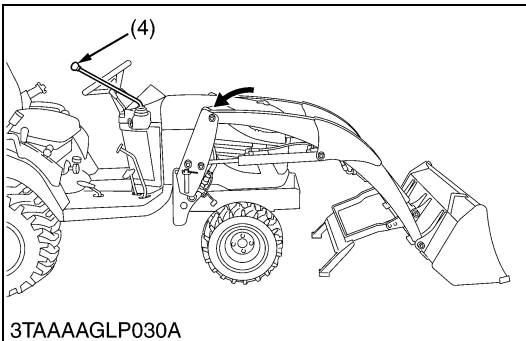
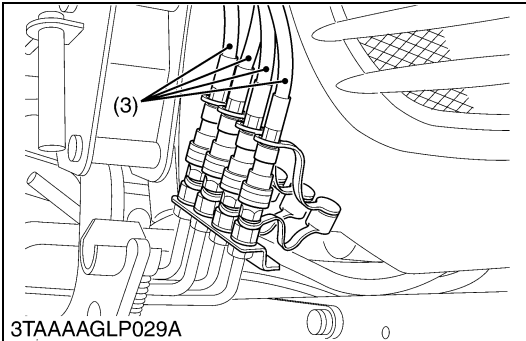
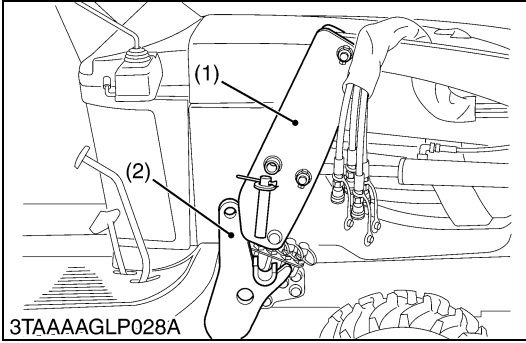

Side Frame and Hoses

1. Slowly drive the tractor between the loader side frames until the rear portion of both side frames touches the main frames as shown.
2. Stop the engine.
3. Connect four hoses with couplers to the nipple on the control valve as indicated with color marks. Then connect the protective caps and plugs to each other.
4. Start the engine and run at idle.
5. Slowly move the loader control lever to dump position to lower the side frames into the main frames and engage the bosses of the main frames to the guide bosses of the side frames. Then lift the front wheels slightly with the loader.

■ IMPORTANT

- Do not attempt to lift the front wheels with the stand.
6. Stop the engine. Reinstall the mounting pins and secure them with the locking rods.
 7. Start the engine.
 8. Raise the boom until the stand can be rotated.
 9. Stop the engine.
 10. Store the stand to their original positions and secure it with the spring pin as shown.
 11. Start the engine.
 12. Lower the boom and level the bucket.

- | | |
|----------------|--------------------------|
| (1) Side Frame | (4) Loader Control Lever |
| (2) Main Frame | (5) Spring Pin |
| (3) Hose | (6) Stand |

W1020231

MECHANISM

CONTENTS

1. HYDRAULIC CIRCUIT SCHEMATIC.....	8-M1
2. CONTROL VALVE ASSEMBLY.....	8-M2
[1] STRUCTURE.....	8-M2
[2] OPERATION.....	8-M3
3. BOOM CYLINDER AND BUCKET CYLINDER.....	8-M10

1. HYDRAULIC CIRCUIT SCHEMATIC

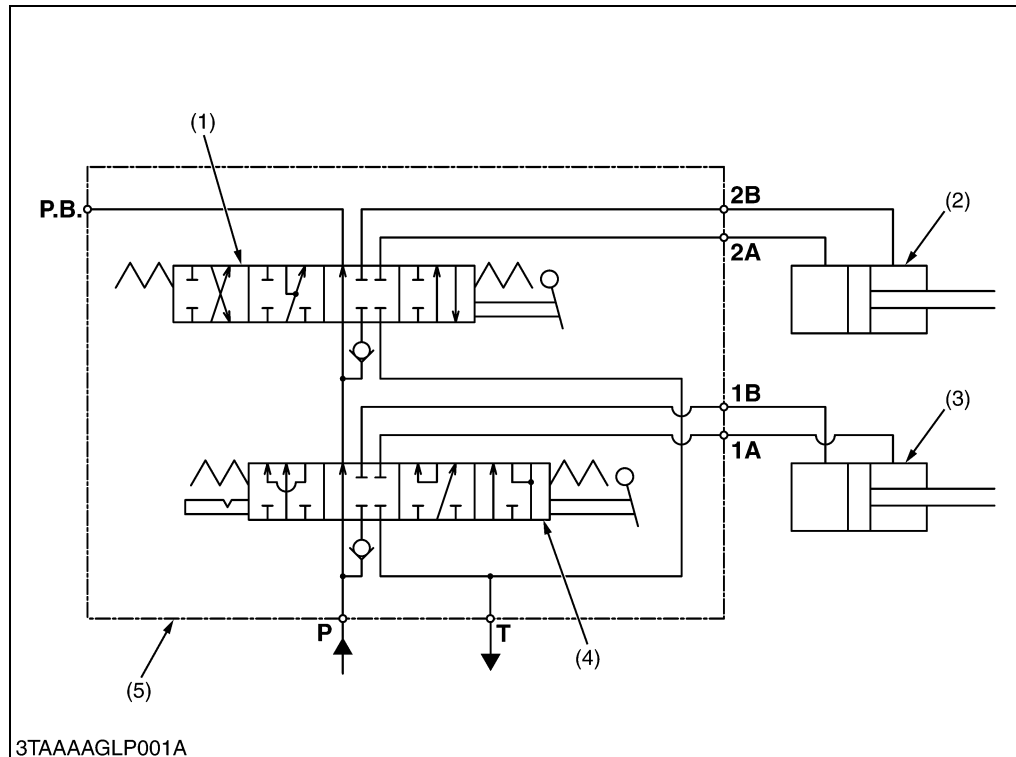

- (1) Bucket Control Valve
- (2) Bucket Cylinder
- (3) Boom Cylinder
- (4) Boom Control Valve
- (5) Control Valve Assembly

P : From Pump
P.B. :To 3-Point Hydraulic System
T : To Tank
1A :1A Port
2A :2A Port
1B :1B Port
2B :2B Port

W1016476

To operate the front loader, the hydraulic oil pressurized by the hydraulic pump flows from **P** port through the boom control valve (4) and the bucket control valve (1) to **P.B.** port or **T** port.

Since relief valve is not equipped in the front loader control valve, the main relief valve in the tractor operates.

2. CONTROL VALVE ASSEMBLY

[1] STRUCTURE

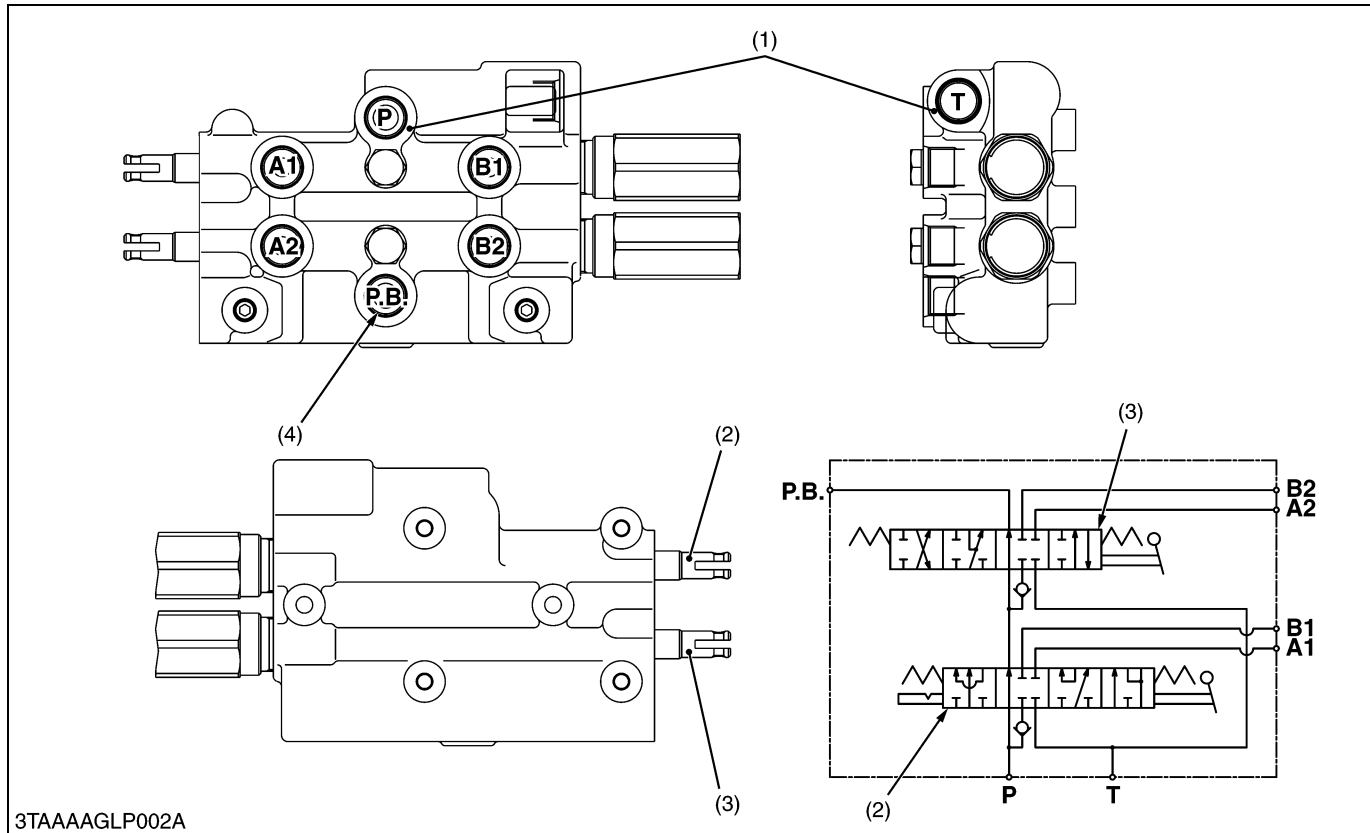

3TAAAAGLP002A

- (1) Inlet and Outlet Section
- (2) Boom Control Valve
- (3) Bucket Control Valve
- (4) Power Beyond

P : P Port (From Pump)
T : T Port (To Tank)

A1 : A1 Port
A2 : A2 Port

B1 : B1 Port
B2 : B2 Port
P.B. : P.B. Port

The control valve assembly is composed of one casting block and four major section as shown above.

(1) Inlet and Outlet Section

This section has **P** and **T** ports.

The **P** port is connected to the **OUTLET** port of hydraulic block by the hydraulic hose.

The **T** port is connected to the **TANK** port of hydraulic block by the hydraulic hose.

(2) Boom Control Section

The boom control valve is of 4-position, 6-connection, detent, spring center type, consisting of a mono block valve housing, spool, load check valve, etc. This valve has **A1** and **B1** ports and controls oil flow to the boom cylinder.

(3) Bucket Control Section

The bucket control valve is of 4-position, 6-connection, no detent, spring center type, consisting of a mono block valve housing, spool, load check valve, etc. This valve has **A2** and **B2** ports and controls oil flow to the bucket cylinder.

(4) Power Beyond

This section has **P.B.** port which is connected to the **INLET** port of hydraulic block by the hydraulic hose, and feeds oil to the three point hydraulic control valve.

[2] OPERATION

■ Neutral

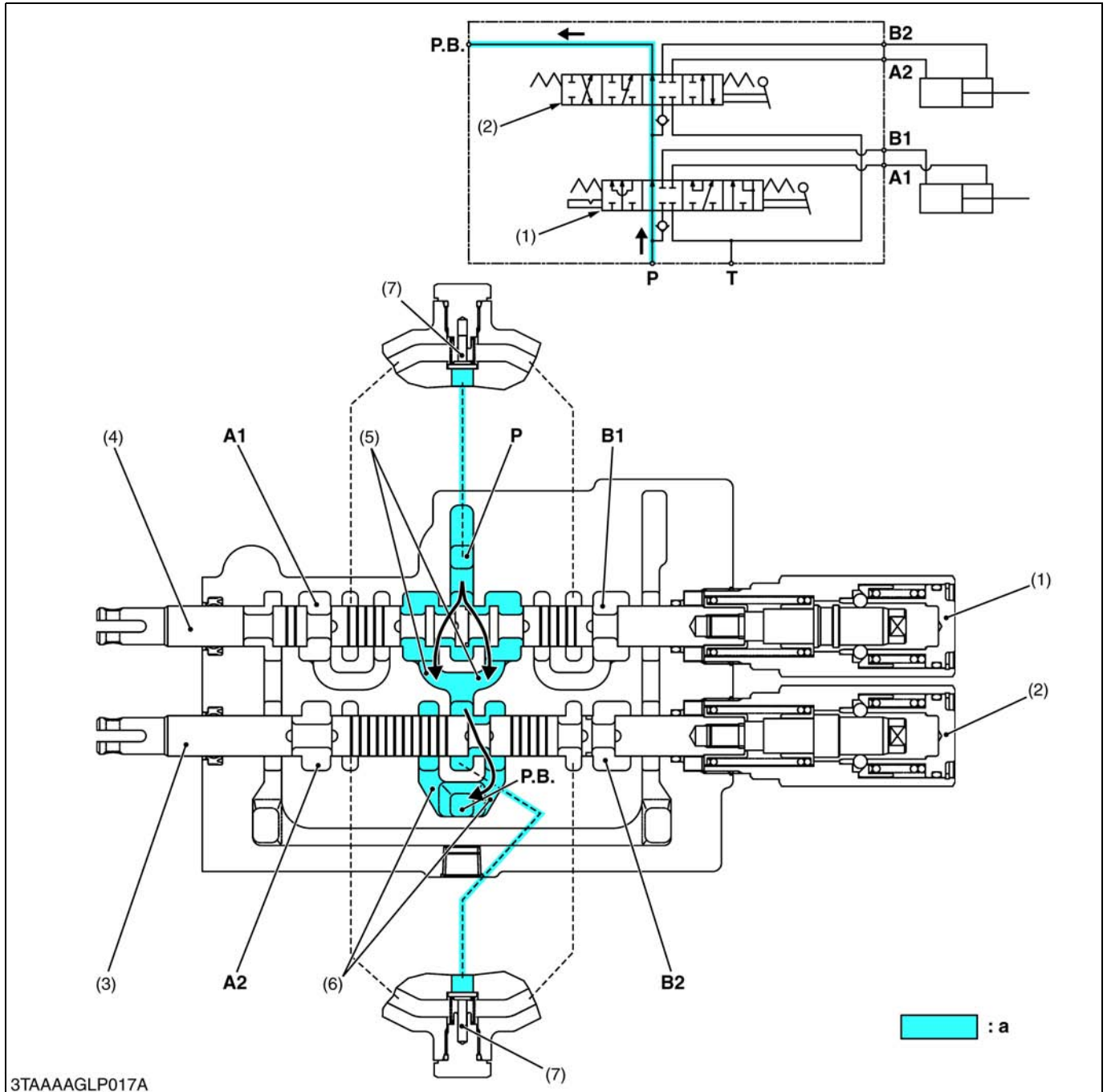

3TAAAAGLP017A

- (1) Boom Control Section
- (2) Bucket Control Section
- (3) Spool
- (4) Spool

- (5) P.B. Passage 1
- (6) P.B. Passage 2
- (7) Load Check Valve

- T : T Port (To Tank)
- P : P Port (From Pump)
- A1 : A1 Port
- A2 : A2 Port

- B1 : B1 Port
- B2 : B2 Port
- P.B. : P.B. Port
- a : Low Pressure

■ Up

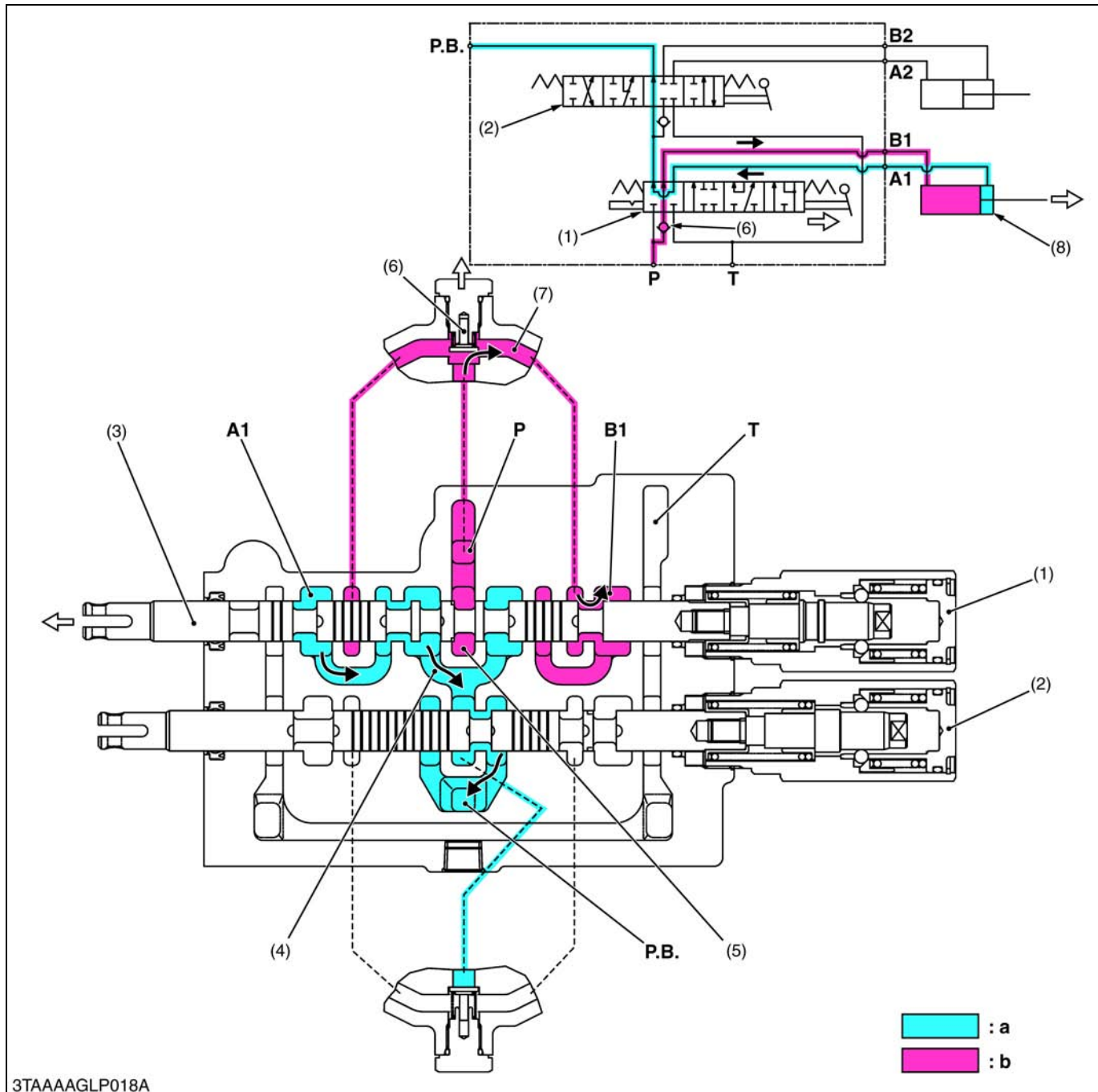

3TAAAAGLP018A

- (1) Boom Control Section
- (2) Bucket Control Section
- (3) Spool
- (4) P.B. Passage 1

- (5) Neutral Passage 1
- (6) Load Check Valve
- (7) Passage 1
- (8) Boom Cylinder

- P : P Port (From Pump)
- T : T Port (To Tank)
- A1 : A1 Port (From Boom Cylinder)

- B1 : B1 Port (To Boom Cylinder)
- P.B. : P.B. Port (To 3 Hitch)
- a : Low Pressure
- b : High Pressure

1. When the hydraulic control lever is set to the "UP" position, the spool (3) of the boom control section (1) moves to the left, which forms oil passages between passage 1 (7) and B1 port, and between A1 port and P.B. passage 1 (4).
2. As the oil passage from the neutral passage 1 (5) to the P.B. passage 1 (4) is closed by the spool (3), the pressure-fed oil from the P port opens the load check valve (6) and flows through the notched section of the spool (3) and B1 port to extend the boom cylinder (8).
3. Return oil from the boom cylinder (8) flows from the A1 port through the passage in the spool (3) and P.B. passage 1 (4) to the bucket control section (3).

■ Down

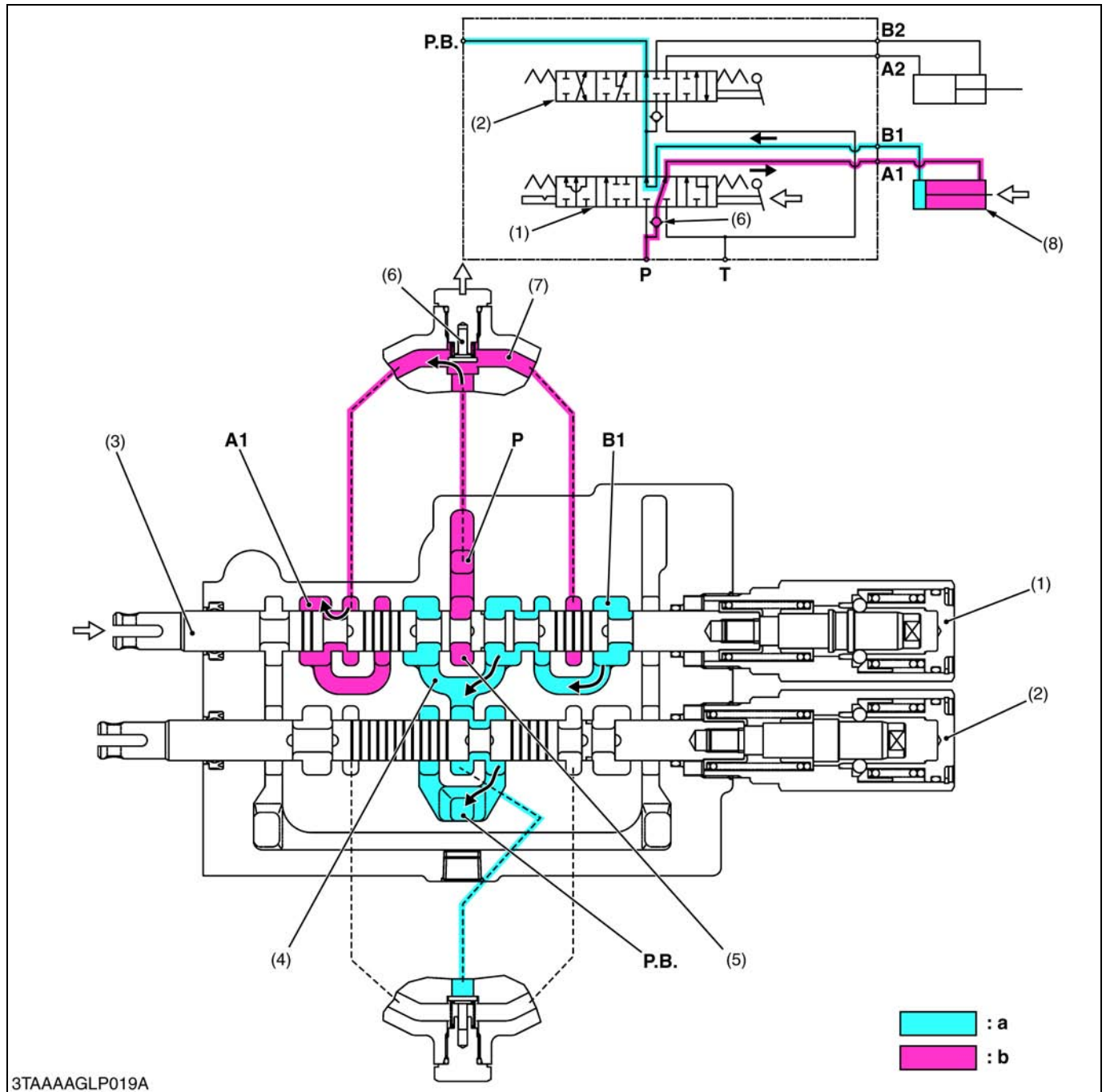

3TAAAAGLP019A

- | | | | |
|----------------------------|-----------------------|--|--|
| (1) Boom Control Section | (5) Neutral Passage 1 | P : P Port (From Pump) | B1 : B1 Port (From Boom Cylinder) |
| (2) Bucket Control Section | (6) Load Check Valve | T : T Port (To Tank) | P.B. : P.B. Port (To 3 Hitch) |
| (3) Spool | (7) Passage 1 | A1 : A1 Port (To Boom Cylinder) | a : Low Pressure |
| (4) P.B. Passage 1 | (8) Boom Cylinder | | b : High Pressure |

1. When the hydraulic control lever is set to the “**DOWN**” position, the spool (3) moves to the right, which forms oil passages between passage 1 (7) and **A1** port, and between **B1** port and **P.B.** passage 1 (4).
2. As the oil passage from the neutral passage 1 (5) to the **P.B.** passage 1 (4) is closed by the spool (3), the pressurized oil from the **P** port opens the load check valve (6) and flows through the notched section of the spool (3) and **A1** port to retract the boom cylinder (8).
3. Return oil from the boom cylinder (8) flows from the **B1** port through the passage in the spool (3) and **P.B.** passage 1 (4) to the bucket control section (2).

■ Floating

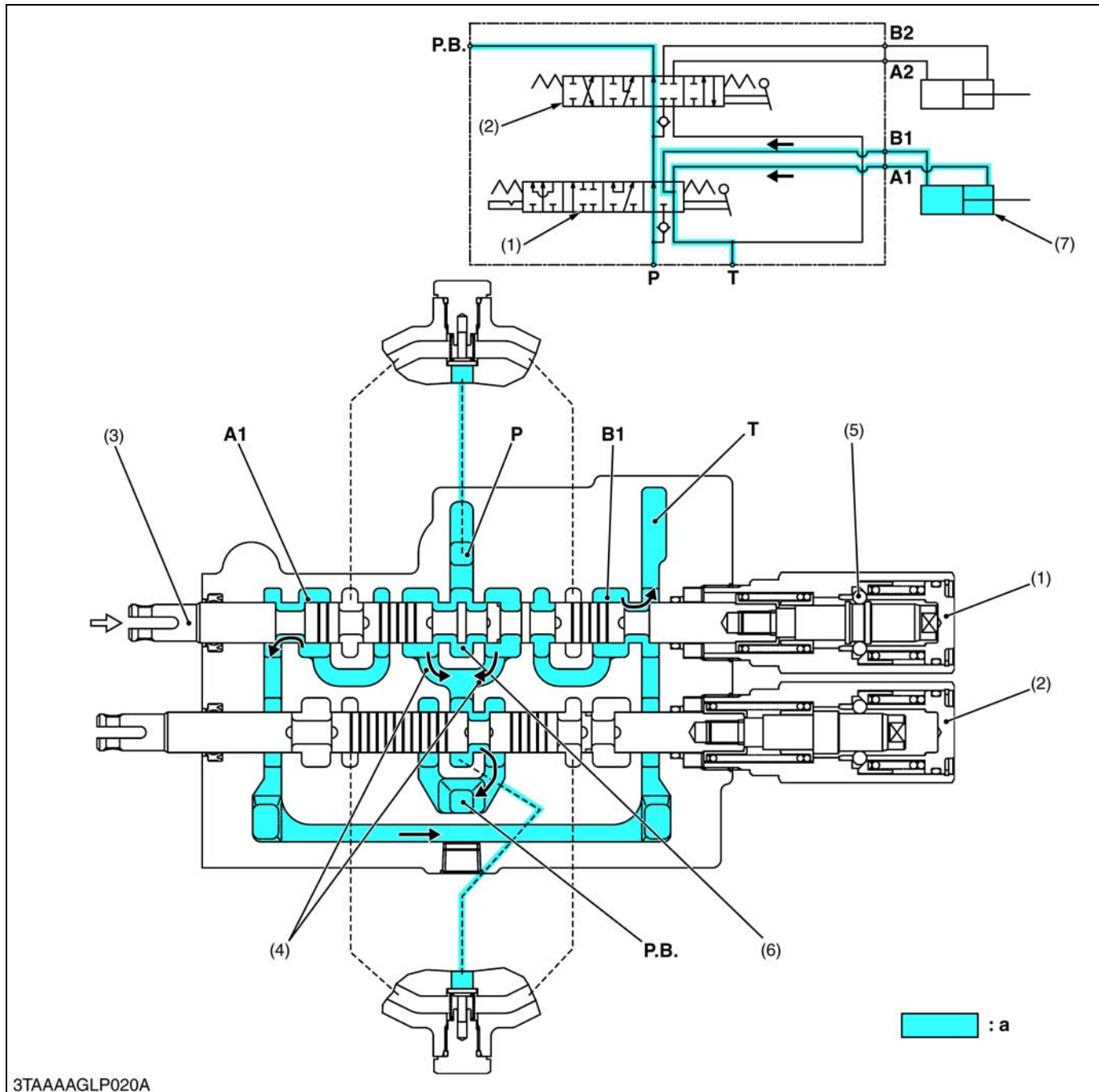

3TAAAAGLP020A

- | | | | |
|----------------------------|-----------------------|-------------------------------|--------------------------------------|
| (1) Boom Control Section | (5) Detent Mechanism | P : P Port (From Pump) | A1 : A1 Port |
| (2) Bucket Control Section | (6) Neutral Passage 1 | T : T Port (To tank) | B1 : B1 Port |
| (3) Spool | (7) Boom Cylinder | | P.B. : P.B. Port (To 3 Hitch) |
| (4) P.B. Passage 1 | | | a : Low Pressure |

1. When the hydraulic control lever is set to the "FLOAT" position, the spool (3) moves further to the right from the "DOWN" position and is retained by the detent mechanism (5).
2. This forms oil passages among the A1 port, B1 port and T port. As a result, oil in the boom cylinder (7) flows freely from the A1 port and B1 port through the T port to the transmission case.
3. Oil entering the P port flows to the bucket control section (2) through the neutral passage 1 (6) and P.B. passage 1 (4).

■ Roll-back

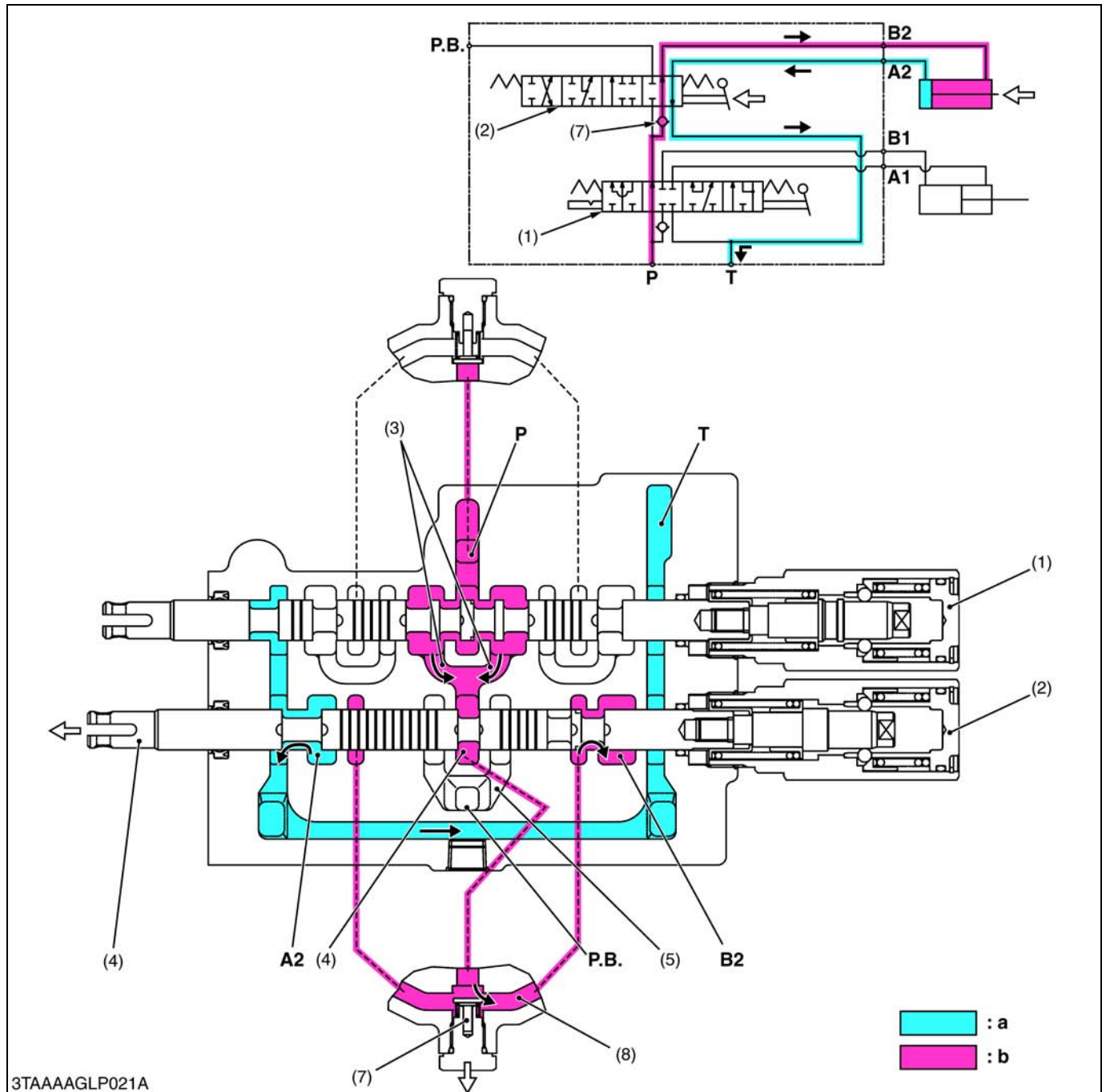

3TAAAAGLP021A

- | | | | |
|----------------------------|----------------------|-------------------------------------|--------------------------|
| (1) Boom Control Section | (6) P.B. Passage 2 | P : P Port (From Pump) | B2 : B2 Port |
| (2) Bucket Control Section | (7) Load Check Valve | T : T Port (To Tank) | (To Bucket Cylinder) |
| (3) P.B. Passage 1 | (8) Passage 2 | P.B. :P.B. Port (To 3 Hitch) | a : Low Pressure |
| (4) Spool | (9) Bucket Cylinder | A2 : A2 Port | b : High Pressure |
| (5) Neutral Passage 2 | | (From Bucket Cylinder) | |

- When the hydraulic control lever is set to the “**ROLL-BACK**” position, the spool (4) of the bucket control section (2) moves to the left, which forms oil passages between passage 2 (8) and **B2** port, and between **A2** port and **T** port.
- The pressure-fed oil from the **P** port flows to the neutral passage 2 (5) through the boom control section (1) and **P.B.** passage 1 (3). As the oil passage from the neutral passage 2 (5) to the **P.B.** passage 2 (6) is closed by the spool (4), this oil opens the load check valve (7), and flows through the notched section of the spool (4) and **B2** port to retract the bucket cylinder (9).
- Return oil from the bucket cylinder (9) flows to the transmission case through the **A2** port and **T** port.

■ Dump 1

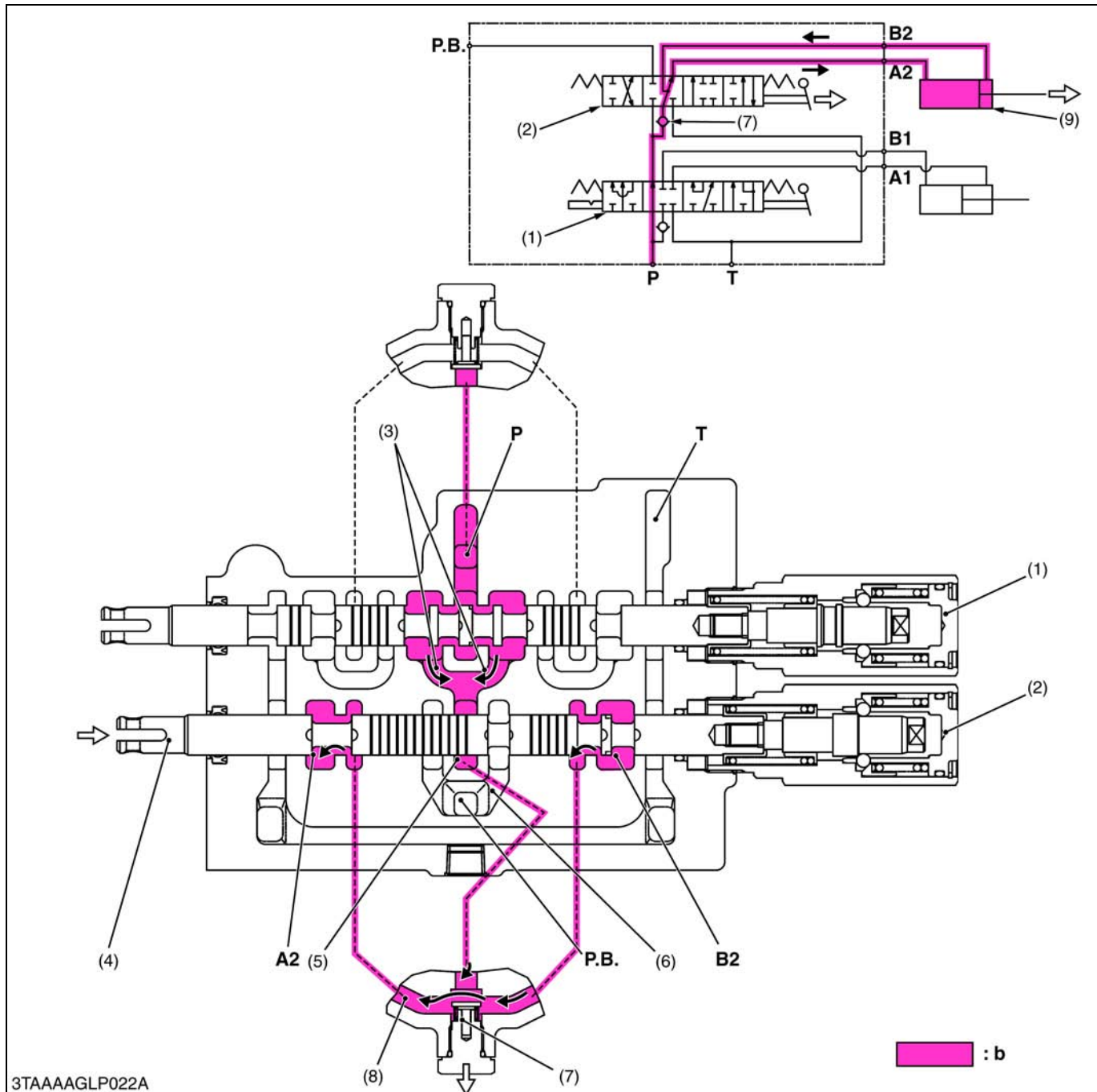

3TAAAAGLP022A

- | | | | |
|----------------------------|----------------------|--------------------------------------|--|
| (1) Boom Control Section | (6) P.B. Passage 2 | P : P Port (From Pump) | A2 : A2 Port (To Bucket Cylinder) |
| (2) Bucket Control Section | (7) Load Check Valve | T : T Port (To Tank) | B2 : B2 Port (From Bucket Cylinder) |
| (3) P.B. Passage 1 | (8) Passage 2 | P.B. : P.B. Port (To 3 Hitch) | b : High Pressure |
| (4) Spool | (9) Bucket Cylinder | | |
| (5) Neutral Passage 2 | | | |

- When the hydraulic control lever is set to the “DUMP 1” position, the spool (4), which forms oil passages among passage 2 (8), **A2** port and **B2** port.
- The pressure-fed oil from the **P** port flows through the boom control valve, opens the load check valve, and flows to the bucket cylinder to extend the cylinder through the notched section of the spool and **A2** port.
- Return oil from the bucket cylinder (9) flows from the **B2** port to the passage 2 (8), and flows to the **A2** port together with the pressure-fed oil from the **P** port. As a result, the dump speed is increased.

(Reference)

- The oil pressure of the **A2** port and **B2** port is identical, but the bucket cylinder extends by the difference of received pressure area (cylinder rod part).

■ Dump 2

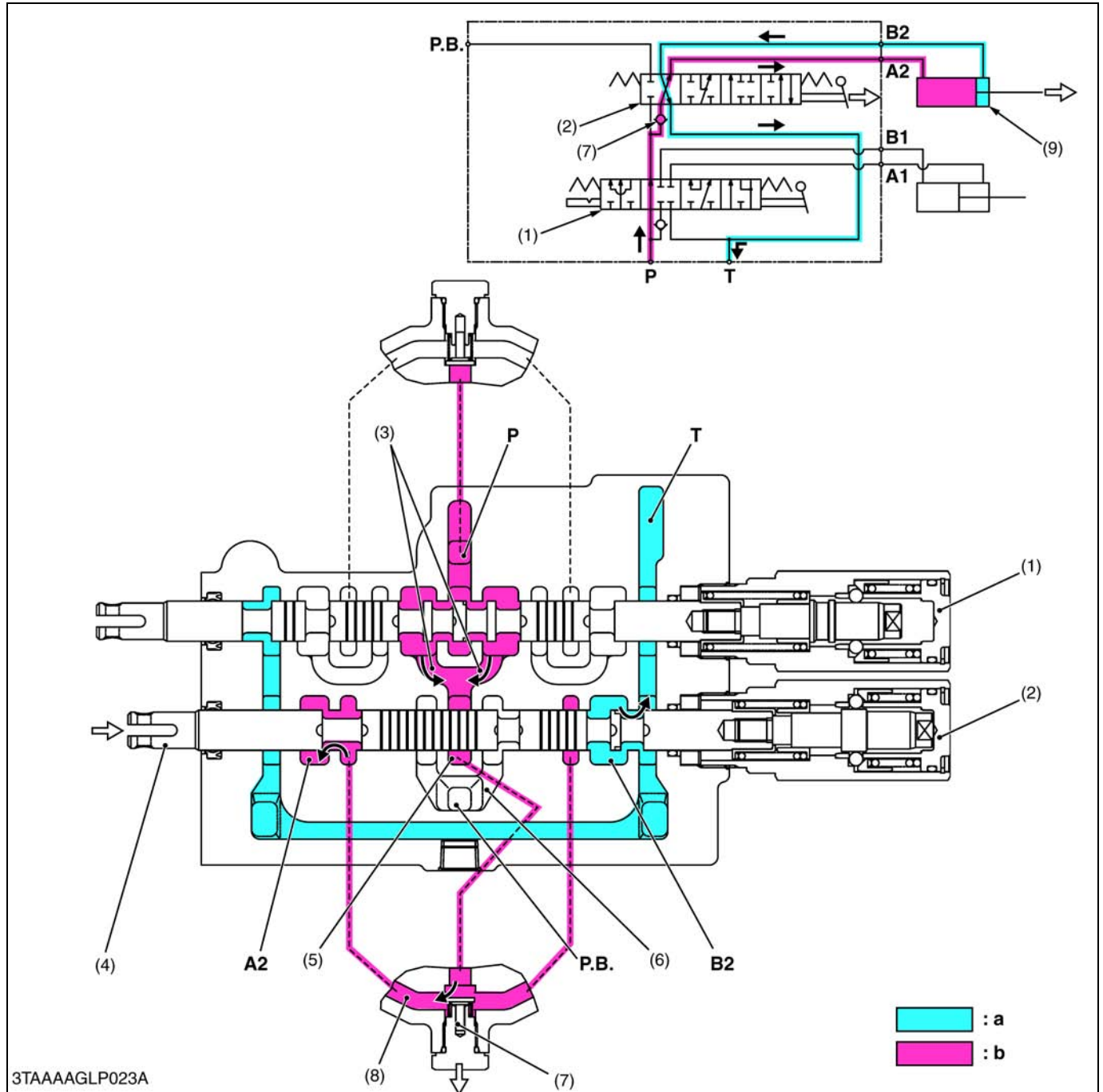

3TAAAAGLP023A

- | | | | |
|----------------------------|----------------------|-------------------------------------|--|
| (1) Boom Control Section | (6) P.B. Passage 2 | P : P Port (From Pump) | A2 : A2 Port (To Bucket Cylinder) |
| (2) Bucket Control Section | (7) Load Check Valve | T : T Port (To Tank) | B2 : B2 Port (From Bucket Cylinder) |
| (3) P.B. Passage 1 | (8) Passage 2 | P.B. :P.B. Port (To 3 Hitch) | a : Low Pressure |
| (4) Spool | (9) Bucket Cylinder | | b : High Pressure |
| (5) Neutral Passage 2 | | | |

- When the hydraulic control lever is set to the "DUMP 2" position, the spool (4) of the bucket control section (2) moves to the right of the bucket control section (2) moves further to the right from the "DUMP 1" position, which forms oil passages between passage 2 (8) and A2 port, and between B2 port and T port.
- The pressure-fed oil from the P port flows to the neutral passage 2 (5) through the boom control section (1) and P.B. passage 1 (3). As the oil passage from the neutral passage 2 (5) to the P.B. passage 2 (6) is closed by the spool (4), this oil opens the load check valve (7) and flows through the notched section of the spool (4) and B2 port to extend the bucket cylinder (9).
- Return oil from the bucket cylinder (9) flows to the transmission case through the B2 port and T port.

3. BOOM CYLINDER AND BUCKET CYLINDER

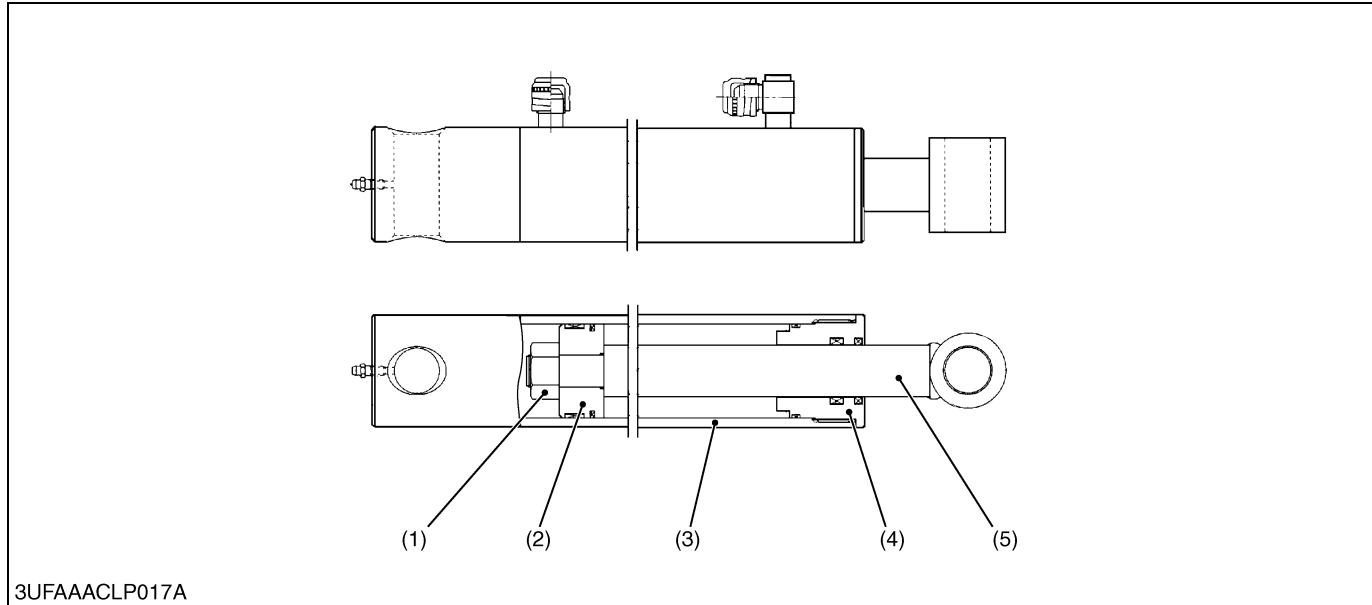

- (1) Nut
- (2) Piston
- (3) Cylinder Tube
- (4) Head
- (5) Piston Rod

Both boom cylinder and bucket cylinder consists of a head (4), cylinder tube (3), piston rod (5), piston (2), and other parts as shown in the figure above. They are single-rod double acting cylinder in which the reciprocating motion of the piston is controlled by hydraulic force applied to both of its ends.

Cylinder Specifications

		LA203	LA243
Boom Cylinder	Cylinder I.D.	40 mm (1.57 in.)	
	Rod O.D.	25 mm (0.98 in.)	
	Stroke	281 mm (11.1 in.)	326 mm (12.8 in.)
Bucket Cylinder	Cylinder I.D.	65 mm (2.56 in.)	
	Rod O.D.	30 mm (1.18 in.)	
	Stroke	204 mm (8.03 in.)	

W1025274

SERVICING

CONTENTS

1. TROUBLESHOOTING	8-S1
2. SERVICING SPECIFICATIONS	8-S2
3. TIGHTENING TORQUES	8-S3
4. CHECKING, DISASSEMBLING AND SERVICING.....	8-S4
[1] CHECKING AND ADJUSTING	8-S1
(1) Control Valve	8-S4
[2] DISASSEMBLING AND ASSEMBLING.....	8-S1
(1) Control Valve	8-S1
(2) Bucket, Boom and Hydraulic Cylinders.....	8-S1
(3) Side Frames, Front Guard and Main Frames	8-S1
[3] SERVICING	8-S10

1. TROUBLESHOOTING

Symptom	Probable Cause	Solution	Reference Page
Boom Does Not Rise	Control valve malfunctioning	Repair or replace	8-S5
	Boom cylinder defective	Repair or replace	8-S7
	Control lever linkage defective	Repair or replace	8-S5
	Hydraulic pump malfunctioning	Repair or replace	5-S13
	Oil filter clogged	Clean or replace	G-14
	Hydraulic hose damaged	Replace	–
Boom Does Not Lower	Control valve malfunctioning	Repair or replace	8-S5
Insufficient Boom Speed	Boom cylinder tube worn or damaged	Replace	8-S7
	Boom cylinder piston ring (piston seal and O-ring) worn or damaged	Replace	8-S8
	Oil leaks from tube joints	Repair	8-S7
	Relief valve setting pressure too low	Adjust	5-S4
	Insufficient transmission fluid	Refill	8-G3
	Dirty relief valve	Clean	5-S4
Bucket Does Not Move	Control valve malfunctioning	Repair or replace	8-S5
	Bucket cylinder defective	Repair or replace	8-S7
	Control lever linkage defective	Repair or replace	8-S5
	Hydraulic pump malfunctioning	Repair or replace	5-S13
	Oil filter clogged	Clean or replace	G-14
	Relief valve spring damaged	Replace	5-S4
	Hydraulic hose damaged	Replace	–
	Dirty relief valve	Clean	5-S4
Insufficient Bucket Speed	Bucket cylinder tube worn or damaged	Replace	8-S7
	Bucket cylinder piston ring (piston seal and O-ring) worn or damaged	Replace	8-S8
	Oil leaks from tube joints	Repair	–
	Insufficient transmission fluid	Refill	8-G3
Front End Loader Drops by its Weight	Boom cylinder tube worn or damaged	Replace	8-S7
	Boom cylinder piston ring (piston seal and O-ring) worn or damaged	Replace	8-S8
	Oil leaks from tube joints	Repair	–
	Control valve malfunctioning	Repair or replace	8-S5

W1014322

2. SERVICING SPECIFICATIONS

Item		Factory Specification	Allowable Limit
Piston Rod	Bend	–	0.25 mm 0.0098 in.

W1013874

3. TIGHTENING TORQUES

Tightening torques of screws, bolts and nuts on the table below are especially specified.
(For general use screws, bolts and nuts : See page 8-G4.)

Item	N·m	kgf·m	lbf·ft
Boom cylinder piston mounting nut	150 to 180	15.3 to 18.3	111 to 132
Bucket cylinder piston mounting nut	350 to 400	35.7 to 40.7	259 to 295
Main frame mounting bolt (M14)	147	15.0	108

W1012736

4. CHECKING, DISASSEMBLING AND SERVICING

[1] CHECKING AND ADJUSTING

(1) Control Valve

Relief Valve Setting Pressure

NOTE

- The relief valve is not installed on this model. However the relief valve of the tractor hydraulic system is used as the relief valve of the front loader. Refer to hydraulic section.

(Reference)

Relief valve setting pressure	Factory spec.	12.3 to 12.7 MPa 125 to 130 kgf/cm ² 1780 to 1840 psi
-------------------------------	---------------	--

Condition

- Engine speed..... Maximum
- Oil temperature..... 45 to 55 °C
113 to 131 °F

W1014688

[2] DISASSEMBLING AND ASSEMBLING

(1) Control Valve



Step and Battery

CAUTION

- When disconnecting the battery cables, disconnect the negative cable from the battery first. When connecting, connect the positive cable to the battery first.

1. Remove the under panel (1).
2. Disconnect the negative cable (3) from the battery (2).
3. Remove the valve covers (4).
4. Remove the HST pedal (5) and the step (6).

- | | |
|--------------------|-----------------|
| (1) Under Panel | (4) Valve Cover |
| (2) Battery | (5) HST Pedal |
| (3) Negative Cable | (6) Step |

W1012394

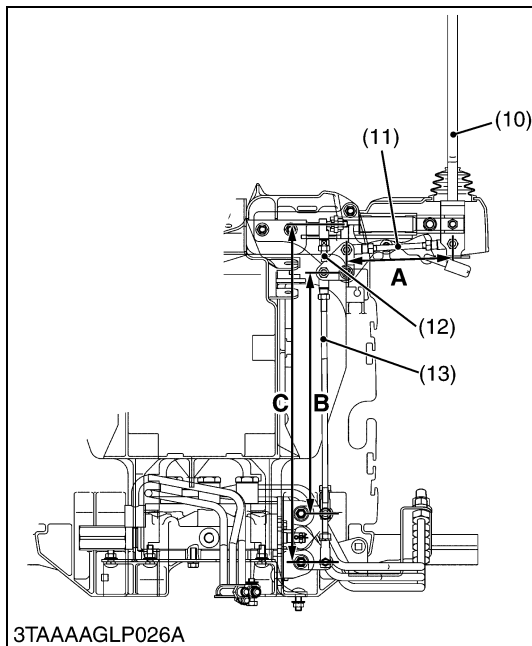
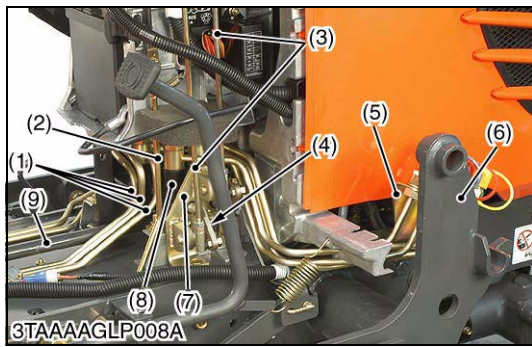

Control Valve

1. Remove the loader frame (6).
2. Disconnect the cruise control rod (2).
3. Disconnect the frame loader control rods (3).
4. Remove the brake spring.
5. Remove the arms (4) from spool end.
6. Remove the stay bolt (5).
7. Remove the valve stay (7).
8. Disconnect the pipes (1).
9. Remove the control valve (8) with pipes.

(When reassembling)

- After reassembling a valve, check for oil leakage by starting up engine.

■ IMPORTANT

- **When starting up engine, watch out for the rotating propeller shaft (9).**

(Reference)

- When adjusting the length of rods, make the lever come to the neutral position.

A : 145 mm (5.71 in.)

B : 315 mm (12.4 in.)

C : 448 mm (17.6 in.)

- | | |
|------------------------------|---------------------------------|
| (1) Pipe | (8) Control Valve |
| (2) Cruise Control Rod | (9) Propeller Shaft |
| (3) Front Loader Control Rod | (10) Front Loader Control Lever |
| (4) Arm | (11) Rod 1 |
| (5) Stay | (12) Rod 2 |
| (6) Loader Frame | (13) Rod 3 |
| (7) Valve Stay | |

W1013200

Disassembling Control Valve

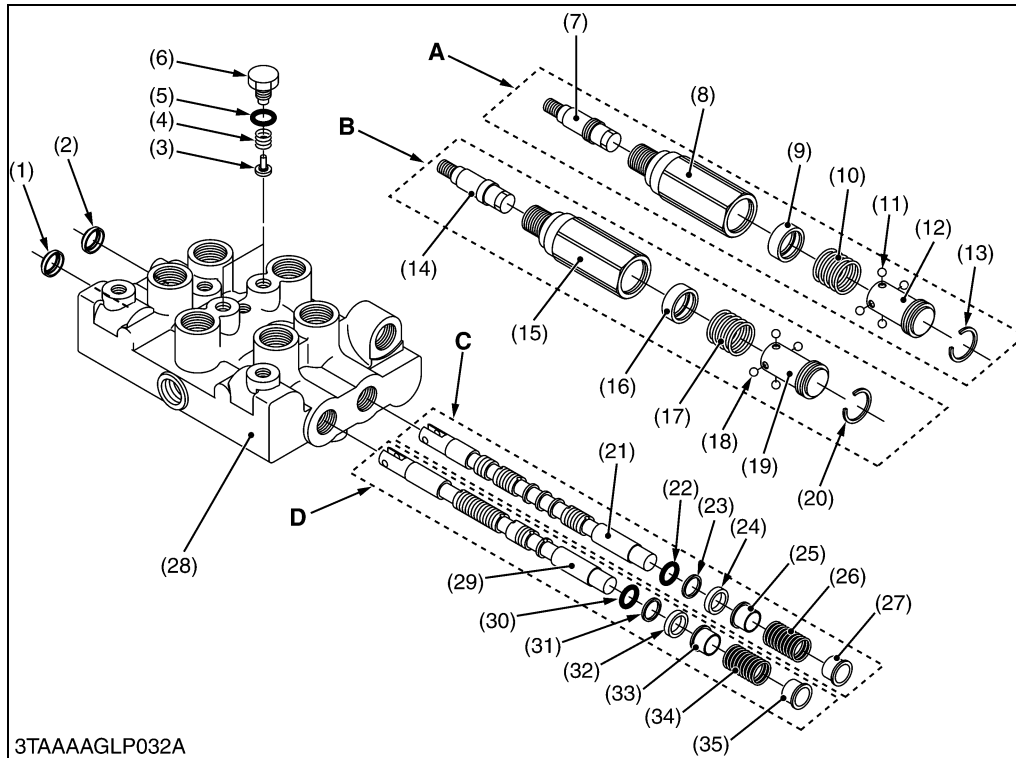

- (1) Dust Seal
- (2) Dust Seal
- (3) Load Check Valve
- (4) Spring
- (5) O-ring
- (6) Plug
- (7) Bolt
- (8) Plug
- (9) Seat
- (10) Spring
- (11) Ball
- (12) Stopper
- (13) Ring
- (14) Bolt
- (15) Plug
- (16) Seat
- (17) Spring
- (18) Ball
- (19) Stopper
- (20) Ring
- (21) Spool
- (22) O-ring
- (23) Back-up Ring
- (24) Collar
- (25) Spring Holder
- (26) Spring
- (27) Spring Holder
- (28) Valve Body
- (29) Spool
- (30) O-ring
- (31) Back-up Ring
- (32) Collar
- (33) Spring Holder
- (34) Spring
- (35) Spring Holder

A, C : Boom Control Section
B, D : Bucket Control Section

W1013558

1. Remove the plugs (6) and take out the spring (4) and load check valve (3).
2. Remove the seal plates (8), (15) with other parts inside plug (C), (D).
3. Draw out the spools (21), (29) with other component parts (A), (B) from the valve body (28).

(When reassembling)

- Clean all parts with a suitable solvent, and dry with a lint-free cloth or air.
- Visually inspect all parts for damage,
- Install the spools to the valve body, not to damage the O-ring.

(2) Bucket, Boom and Hydraulic Cylinders

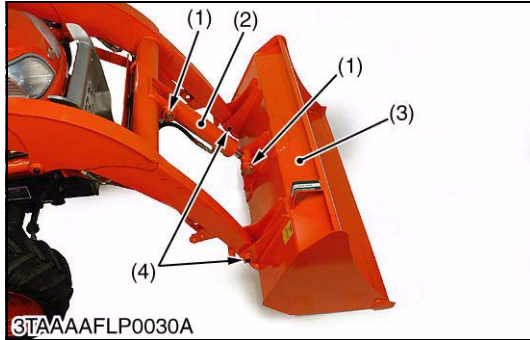

Bucket and Bucket Cylinder

1. Remove the pins (4) the lower pin (1) and remove the bucket (3).
2. Disconnect the hydraulic hoses from the bucket cylinder (2).
3. Remove the upper pin (1) and remove the bucket cylinder (2).

(When reassembling)

- When installing the bucket cylinder (2), the hydraulic port should face inside and be careful of the direction of grease fittings.

- | | |
|---------------------|------------|
| (1) Pin | (3) Bucket |
| (2) Bucket Cylinder | (4) Pin |

W1016780

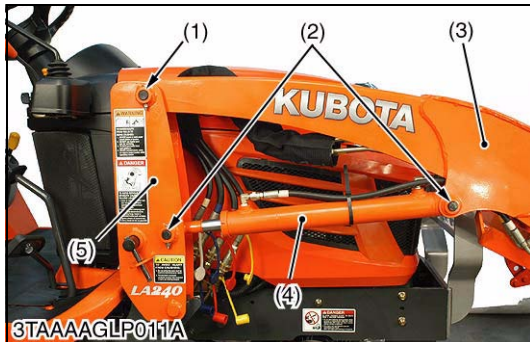

Boom Cylinder and Hydraulic Tubes

1. Disconnect the hydraulic hoses from the boom cylinders (4).
2. Remove the pins (2) and remove the boom cylinders (4).
3. Disconnect the hydraulic hoses (6) with quick couplers at the control valve.
4. Remove the pins (1) and remove the boom (3) from the side frame (5).
5. Remove the hydraulic tubes (7) from the boom (3).

(When reassembling)

- When installing the boom cylinders (4), the hydraulic port should face inside and be careful of the direction of grease fittings.

- | | |
|-------------------|--------------------|
| (1) Pin | (5) Side Frame |
| (2) Pin | (6) Hydraulic Hose |
| (3) Boom | (7) Hydraulic Tube |
| (4) Boom Cylinder | |

W1016879

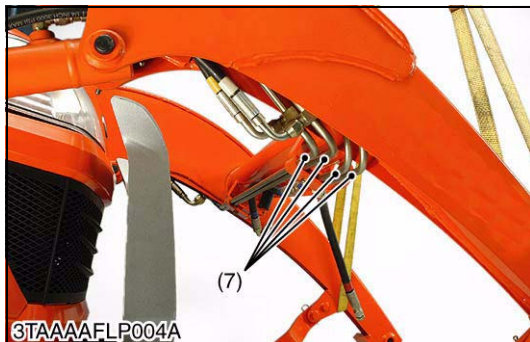
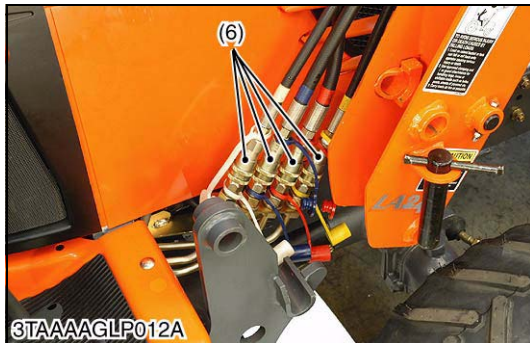

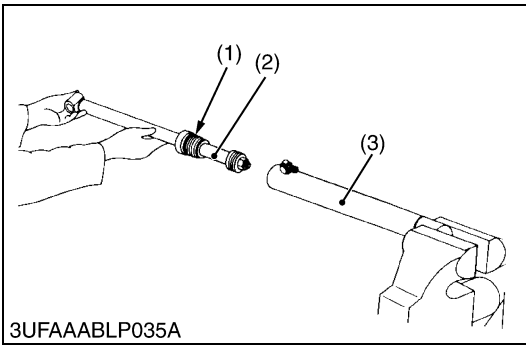

3UFAAABLP035A

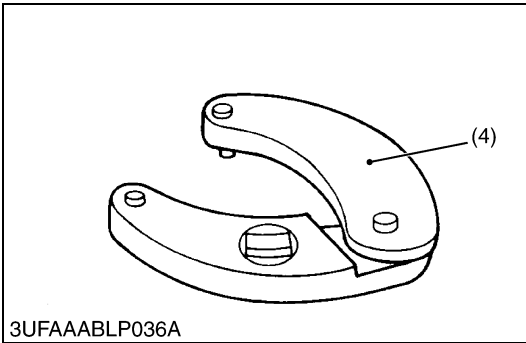

3UFAAABLP036A

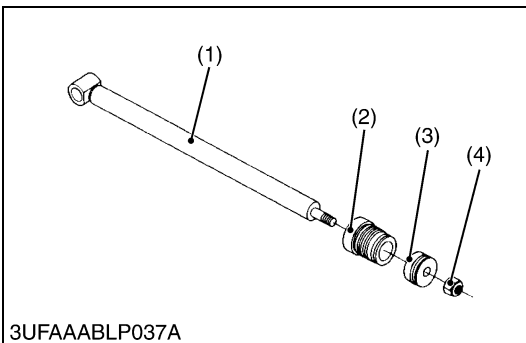

3UFAAABLP037A

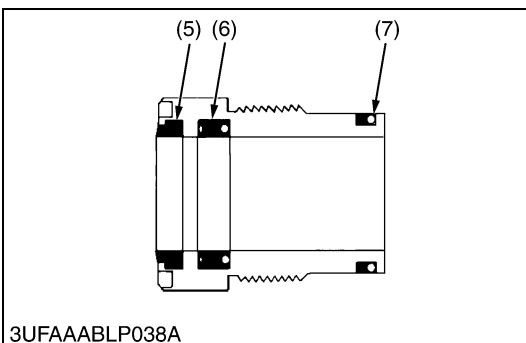

3UFAAABLP038A

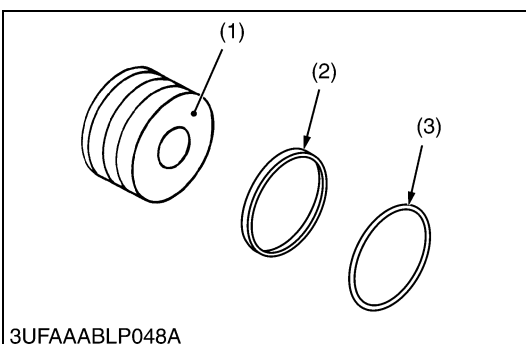

3UFAAABLP048A

Piston Rod Assembly

1. Drain hydraulic oil from the cylinder, and secure the tube end of the cylinder in a vise.
2. Unscrew the cylinder head (1) with the adjustable gland nut wrench (4).
3. Pull out the piston rod assembly (2) from the cylinder tube (3).

(When reassembling)

- Visually inspect the cylinder tube for signs of scoring or damage.
- Insert the piston rod assembly to the cylinder tube, not to damage the piston seal on the piston.
- Install the cylinder head to the cylinder tube, not to damage the O-ring on the cylinder head.

- (1) Cylinder Head (3) Cylinder Tube
 (2) Piston Rod Assembly (4) Adjustable Gland Nut Wrench

W1017050

Cylinder Head, Piston and Nut

1. Secure the rod end in a vise.
2. Unscrew the nut (4), and remove the piston (3) and cylinder head (2) from the piston rod (1).

(When reassembling)

- Visually inspect all parts for signs of scoring or damage.
- Insert the piston rod to the cylinder head, not to damage the wiper seal (5) and oil seal (6).

Tightening torque	Boom cylinder piston mounting nut	150 to 180 N·m 15.3 to 18.3 kgf·m 111 to 132 ft-lbs
	Bucket cylinder piston mounting nut	350 to 400 N·m 35.7 to 40.7 kgf·m 259 to 295 ft-lbs

- (1) Piston Rod (5) Wiper Seal
 (2) Cylinder Head (6) Oil Seal
 (3) Piston (7) O-ring
 (4) Nut

W1017322

Piston Seal and O-ring

1. Remove the piston seal (2) and O-ring (3) from the piston (1).

■ IMPORTANT

- When installing the O-ring (3) and piston seal (2) to the piston (1), use the slide jig and correcting jig as shown in “Special Tools” of “GENERAL” section.

- (1) Piston (a) Slide Jig
 (2) Piston Seal (b) Correcting Jig
 (3) O-ring

W1017590

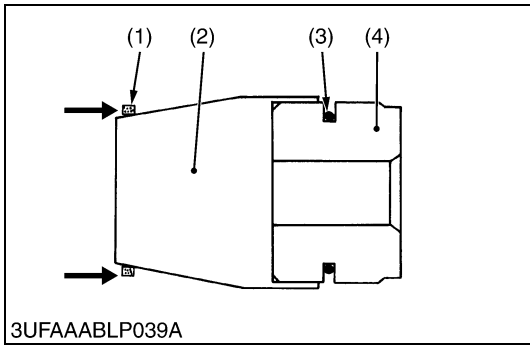

3UFAAABLP039A

Installing O-ring and Piston Seal

1. Place the slide jig (2) on the piston (4).
2. Install the O-ring (3) to the piston using the slide jig.
3. Install the piston seal (1) over the O-ring using the slide jig.
4. Compress the piston seal to the correct size by installing the piston into the correcting jig (5).

NOTE

- Do not turn (roll) the piston seal as you install it.

- | | |
|-----------------|--------------------|
| (1) Piston Seal | (4) Piston |
| (2) Slide Jig | (5) Correcting Jig |
| (3) O-ring | |

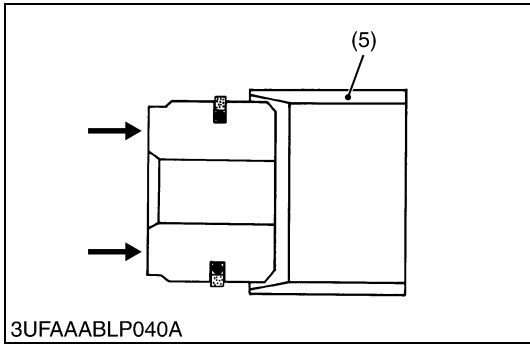

3UFAAABLP040A

W1018621

(3) Side Frames, Front Guard and Main Frames

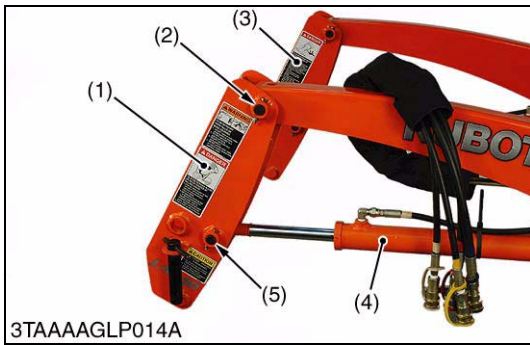

3TAAAAGLP014A

Side Frames

1. Remove the pins (2), (5).
2. Remove the side frames (1) from the boom assembly (3) and the boom cylinder (4).

- | | |
|-------------------|-------------------|
| (1) Side Frame | (4) Boom Cylinder |
| (2) Pin | (5) Pin |
| (3) Boom Assembly | |

W1015835

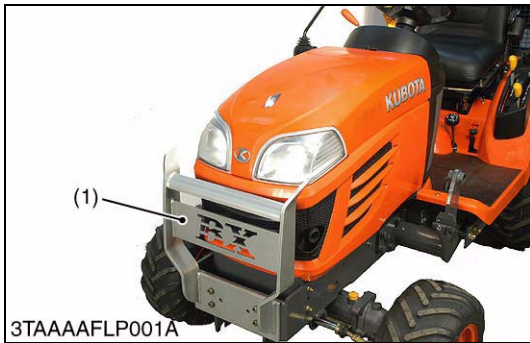

3TAAAFLP001A

Front Guard

1. Remove the front guard (1).

- | |
|-----------------|
| (1) Front Guard |
|-----------------|

W1015954

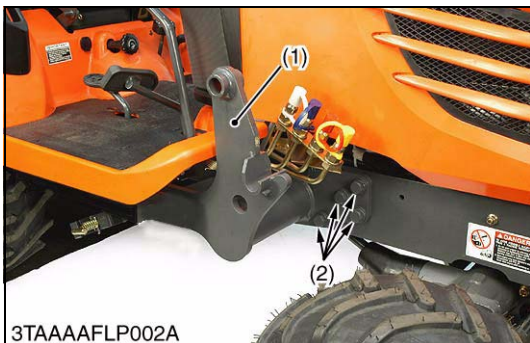

3TAAAFLP002A

Main Frames

1. Remove the main frame mounting bolts and nuts (2) from the tractor body.
2. Remove the main frame (1).

Tightening torque	Main frame mounting bolt (M14)	147 N·m 15.0 kgf·m 108 ft·lbs
-------------------	--------------------------------	-------------------------------------

- | | |
|----------------|------------------------------|
| (1) Main Frame | (2) Main Frame Mounting Bolt |
|----------------|------------------------------|

W1016042

[3] SERVICING

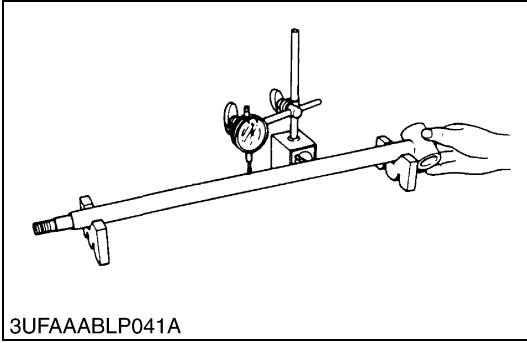

Piston Rod Bend

1. Place piston rod on V blocks.
2. Set a dial indicator on the center of the rod.
3. Turn the piston rod and read the dial indicator.
4. If the measurement exceeds the allowable limit, replace it.

Piston rod bend	Allowable limit	0.25 mm 0.0098 in.
-----------------	-----------------	-----------------------

W1017385

EDITOR:

KUBOTA FARM & INDUSTRIAL MACHINERY SERVICE, LTD.

64, ISHIZU-KITAMACHI, SAKAI-KU, SAKAI-CITY, OSAKA, 590-0823, JAPAN

PHONE : (81)72-241-1129

FAX : (81)72-245-2484

E-mail : ksos-pub@kubota.co.jp
