

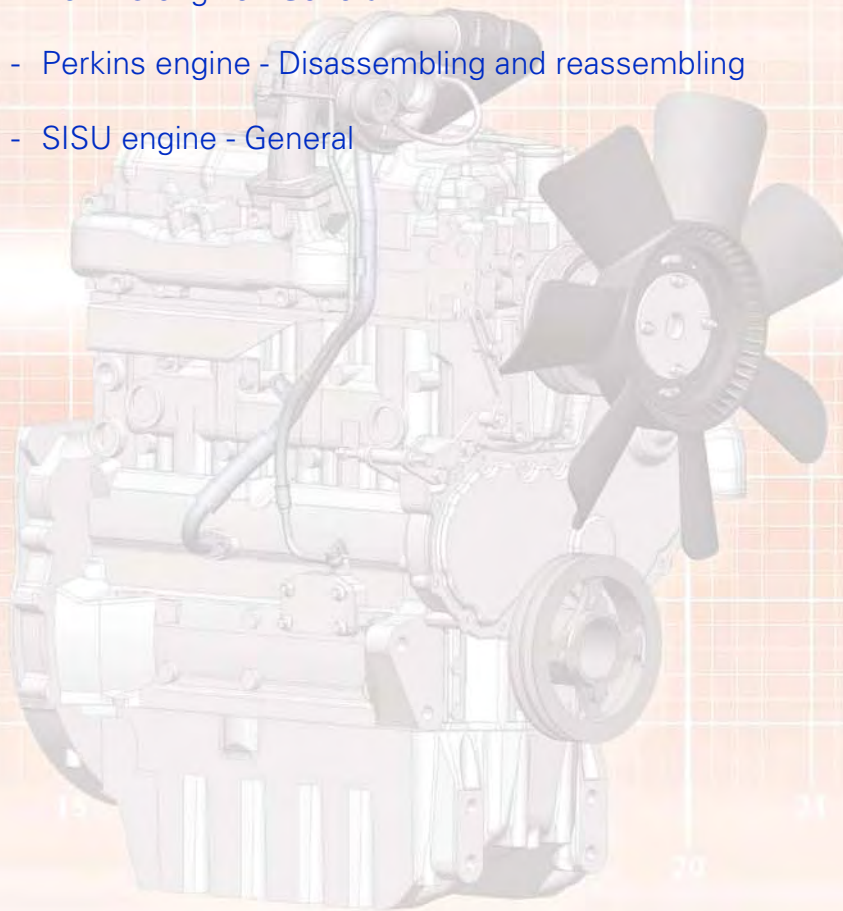

03 - Engine

CONTENTS

- 3A10 - Perkins engine - General
- 3A11 - Perkins engine - Disassembling and reassembling
- 3B10 - SISU engine - General



Engine



5400

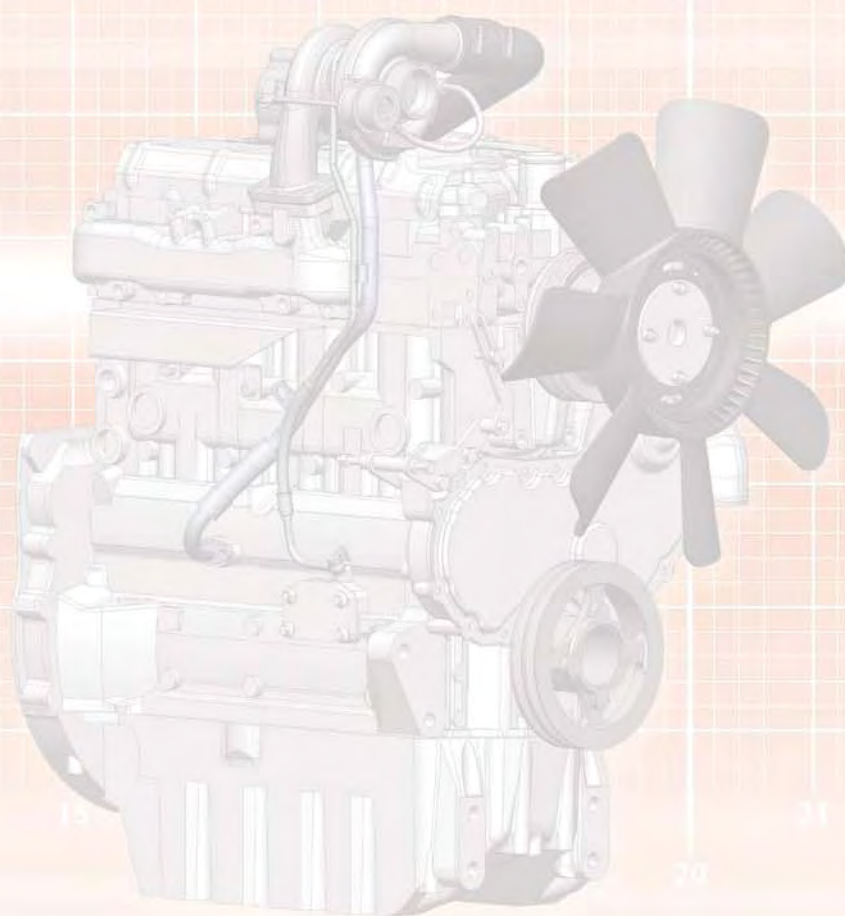

3A10- Perkins engine - General

CONTENTS

A . Introduction 3

B . Specifications and standards relating to fuel, oil and coolant 3

C . Main specifications 4

A . Introduction

This section only provides general information about Perkins engines used on this tractor series.

B . Specifications and standards relating to fuel, oil and coolant

The engines fitted on this tractor series comply with standards concerning emissions imposed by the authorities (EU97/68/EC Stage 2 and EPA 40 CFR 89 Tier 2).

Fluids used in these engines must be of the correct quality and the servicing schedule must be observed to keep pollution emission levels low and to maintain the tractor's performance throughout its service life.

Fuel quality:

The fuel must conform to the DIN EN 590 standard and the following specifications:

Density (at 15°C): 0.82 to 0.84 kg/dm³

Viscosity (at 40°C): 2 to 4.5 mm²/sec

Cetane Index: min 51

Sulphur content: max 0.005 p-%

Water content: max 200 mg/kg

Oil quality:

The oil used must conform to the API CH-4 standard.

Coolant quality:

The coolant used must comply with standard ASTM D 3306. It must be composed of pure water and ethylene/propylene glycol antifreeze agent in the following proportions:

40 - 60% water

40 - 60% antifreeze

The ideal ratio is around 50% water to 50% antifreeze.

Perkins engine - General

C . Main specifications

Model	5425
Engine type	1104C-44
Perkins engine list N° (Standard / Steep Nose)	RE 37873 / RE 37917
No. of cylinders	4
Bore	105
Stroke	127
Cubic capacity	4.4
Compression ratio	19.3/1
Compression pressure (kPa)	2000/3500
Permissible compression deviation between cylinders (kPa)	350
Output at 2200 rpm (kw) ISO	73 (54)
Maximum torque (Nm/lbf.ft)	294
at speed (rpm)	1400
Idle speed	950
Nominal speed	2200
Maximum speed at no load	2354
Injection pump	
Brand and type	Bosch VE10
Rotation	Clockwise
Static timing angle (degrees)	4°
Engine position	TDC
Engine check angle (degrees)	pin
Pump check angle (degrees)	pin
Firing order	1, 3, 4, 2
Injectors	
Brand	Delphi
New and servicing setting (bar)	294
Aspiration system	Atmospheric
Valve spring	single
Valve seat insert (inlet/exhaust)	yes
Valve angle	0.30°/0.30°
Inlet/exhaust valve clearance (mm)	0.20/0.45
Oil cooler	yes
No. of thermostats	1
Opening temperature (start/full)	79°C/93°C
Piston cooling nozzle	yes
Oil filter	1
Fuel filter	1

Perkins engine - General

Model	5435
Engine type	1104C-44T
Perkins engine list N° (Standard / Steep Nose)	RE 37831 / RE 37919
No. of cylinders	4
Bore	105
Stroke	127
Cubic capacity	4.4
Compression ratio	19.3/1
Compression pressure (kPa)	2000/3500
Permissible compression deviation between cylinders (kPa)	350
Output at 2200 rpm (kw) ISO	81 (60)
Maximum torque (Nm/lbf.ft) at speed (rpm)	345/255 1400
Idle speed	950
Nominal speed	2200
Maximum speed at no load	2354
Injection pump	
Brand and type	Bosch VE10
Rotation	Clockwise
Static timing angle (degrees)	4°
Engine position	TDC
Engine check angle (degrees)	pin
Pump check angle (degrees)	pin
Firing order	1, 3, 4, 2
Injectors	
Brand	Delphi
New and servicing setting (bar)	294
Aspiration system	Atmospheric
Valve spring	single
Valve seat insert (inlet/exhaust)	yes
Valve angle	0.30°/0.30°
Inlet/exhaust valve clearance (mm)	0.20/0.45
Oil cooler	yes
No. of thermostats	1
Opening temperature (start/full)	79°C/93°C
Piston cooling nozzle	yes
Oil filter	1
Fuel filter	1

Perkins engine - General

Model	5445
Engine type	1104C-44T
Perkins engine list N° (Standard / Steep Nose)	RG 37832 / RG 37915
No. of cylinders	4
Bore	105
Stroke	127
Cubic capacity	4.4
Compression ratio	18.2/1
Compression pressure (kPa)	2000/3500
Permissible compression deviation between cylinders (kPa)	350
Output at 2200 rpm (kw) ISO	90 (67)
Maximum torque (Nm/lbf.ft) at speed (rpm)	380 1400
Idle speed	950
Nominal speed	2200
Maximum speed at no load	2354
Injection pump	
Brand and type	Lucas DP 210
Rotation	Clockwise
Static timing angle (degrees)	4°
Engine position	TDC
Engine check angle (degrees)	pin
Pump check angle (degrees)	pin
Firing order	1, 3, 4, 2
Injectors	
Brand	Delphi
New and servicing setting (bar)	294
Aspiration system	
Type	Turbo + Waste Gate
Valve spring	Garrett GT25
Valve seat insert (inlet/exhaust)	single
Valve angle	yes
Inlet/exhaust valve clearance (mm)	0.30°/0.30°
Oil cooler	0.20/0.45
No. of thermostats	yes
Opening temperature (start/full)	1
Piston cooling nozzle	79°C/93°C
Oil filter	yes
Fuel filter	1

Perkins engine - General

Model	5455
Engine type	1104C-44T
Perkins engine list N° (Standard / Steep Nose)	RG 37826 / RG 37916
No. of cylinders	4
Bore	105
Stroke	127
Cubic capacity	4.4
Compression ratio	18.2/1
Compression pressure (kPa)	2000/3500
Permissible compression deviation between cylinders (kPa)	350
Output at 2200 rpm (kw) ISO	100 (74.5)
Maximum torque (Nm/lbf.ft)	415
at speed (rpm)	1400
Idle speed	950
Nominal speed	2200
Maximum speed at no load	2354
Injection pump	
Brand and type	Lucas DP 210
Rotation	Clockwise
Static timing angle (degrees)	4°
Engine position	TDC
Engine check angle (degrees)	pin
Pump check angle (degrees)	pin
Firing order	1, 3, 4, 2
Injectors	
Brand	Delphi
New and servicing setting (bar)	294
Aspiration system	Turbo + Waste Gate
Type	Garrett GT25
Valve spring	single
Valve seat insert (inlet/exhaust)	yes
Valve angle	0.30°/0.30°
Inlet/exhaust valve clearance (mm)	0.20/0.45
Oil cooler	yes
No. of thermostats	1
Opening temperature (start/full)	79°C/93°C
Piston cooling nozzle	yes
Oil filter	1
Fuel filter	1

Perkins engine - General

Model	5460
Engine type	1104C-44TA
Perkins engine list no.	RJ 37833
No. of cylinders	4
Bore	105
Stroke	127
Cubic capacity	4.4
Compression ratio	18.2/1
Compression pressure (kPa)	2000/3500
Permissible compression deviation between cylinders (kPa)	350
Output at 2200 rpm (kw) ISO	112 (83.5)
Maximum torque (Nm/lbf.ft) at speed (rpm)	471 1400
Idle speed	950
Nominal speed	2200
Maximum speed at no load	2354
Injection pump	
Brand and type	Lucas DP 210
Rotation	Clockwise
Static timing angle (degrees)	4°
Engine position	TDC
Engine check angle (degrees)	pin
Pump check angle (degrees)	pin
Firing order	1, 3, 4, 2
Injectors	
Brand	Delphi
New and servicing setting (bar)	294
Aspiration system	Turbo + Wastegate + Intercooler air/air
Type	Garrett GT25
Valve spring	single
Valve seat insert (inlet/exhaust)	yes
Valve angle	0.30°/0.30°
Inlet/exhaust valve clearance (mm)	0.20/0.45
Oil cooler	yes
No. of thermostats	1
Opening temperature (start/full)	79°C/93°C
Piston cooling nozzle	yes
Oil filter	1
Fuel filter	1

Perkins engine - General

Model	5465
Engine type	1106C-E66TA
Perkins engine list no.	VK 31483 (up to 21/09/03) VK 31486 (from 22/09/03)
No. of cylinders	6
Bore	100
Stroke	127
Cubic capacity	6
Compression ratio	17.25/1
Compression pressure (kPa)	2000/3500
Permissible compression deviation between cylinders (kPa)	350
Output at 2200 rpm (kw) ISO	117 (87)
Maximum torque (Nm/lbf.ft)	500
at speed (rpm)	1400
Idle speed	950
Nominal speed	2200
Maximum speed at no load	2354
Injection pump	
Brand and type	Bosch VP30
Rotation	Clockwise
Static timing angle (degrees)	4°
Engine position	TDC
Engine check angle (degrees)	pin
Pump check angle (degrees)	pin
Firing order	1, 5, 3, 6, 2, 4
Injectors	
Brand	Bosch
New and servicing setting (bar)	294
Aspiration system	
Aspiration system	Turbo + Wastegate + Intercooler air/air
Type	Garrett GT35
Valve spring	single
Valve seat insert (inlet/exhaust)	yes
Valve angle	0.46°/0.31°
Inlet/exhaust valve clearance (mm)	0.20/0.45
Oil cooler	yes
No. of thermostats	1
Opening temperature (start/full)	83°C/93°C
Piston cooling nozzle	yes
Oil filter	1
Fuel filter	1 (+ 1 prefilter)

Perkins engine - General

Model	5460 SA (Orchard cab)
Engine type	1104C-44TA
Perkins engine list no.	RJ 37833
No. of cylinders	4
Bore	105
Stroke	127
Cubic capacity	4.4
Compression ratio	18.2/1
Compression pressure (kPa)	2000/3500
Permissible compression deviation between cylinders (kPa)	350
Output at 2200 rpm (kw) ISO	112 (83.5)
Maximum torque (Nm/lbf.ft) at speed (rpm)	471 1400
Idle speed	950
Nominal speed	2200
Maximum speed at no load	2354
Injection pump	
Brand and type	Lucas DP 210
Rotation	Clockwise
Static timing angle (degrees)	4°
Engine position	TDC
Engine check angle (degrees)	pin
Pump check angle (degrees)	pin
Firing order	1, 3, 4, 2
Injectors	
Brand	Delphi
New and servicing setting (bar)	294
Aspiration system	
Aspiration system	Turbo + Wastegate + Intercooler air/air
Type	Garrett GT25
Valve spring	single
Valve seat insert (inlet/exhaust)	yes
Valve angle	0.30°/0.30°
Inlet/exhaust valve clearance (mm)	0.20/0.45
Oil cooler	yes
No. of thermostats	1
Opening temperature (start/full)	79°C/93°C
Piston cooling nozzle	yes
Oil filter	1
Fuel filter	1

3A11 - Perkins engine - Disassembling and reassembling

CONTENTS

A . General	3
B . Removing and refitting adjacent components (4-cylinder engine)	4
C . Timing the engine at Top Dead Centre on the first cylinder (4-cylinder engine) . . .	9
D . Removing the injection pump (4-cylinder engine)	10
E . Refitting the injection pump (4-cylinder engine)	12
F . Removing and refitting adjacent components (6-cylinder engine)	14
G . Timing the engine (6-cylinder engine)	18
H . Removing the injection pump (6-cylinder engine)	20
I . Refitting the injection pump (6-cylinder engine)	21
J . Service tools	23

Perkins engine - Disassembling and reassembling

A . General

This section provides instructions for removing and refitting the injection pump on Perkins 1104 (4-cylinder) and 1106 (6-cylinder) engines.

The injection pumps fitted on 4-cylinder engines are mechanical. Two models are fitted:

- Bosch VE10
- Delphi DP210

The injection pumps fitted on 6-cylinder engines are electronic injection type. The pump fitted is a Bosch VP30.

Perkins engine - Disassembling and reassembling

B . Removing and refitting adjacent components (4-cylinder engine)

Removing fuel injection channels

1. Remove the front bonnet body.
2. Clean the injector cover, channels and parts close to the injectors to prevent impurities from entering the system.
3. Remove the injector cover (1) (Fig. 1) by taking the screws (2) out of the cover plate.
4. Make indelible marks on the channel locations to make reassembly easier.
5. Disconnect the injection channels on the injector side.
6. Disconnect the injection channels on the injection pump side.
NOTE: Position a container to recover the fuel contained in the channels.
7. Disassemble or loosen the injection channel flanges. Remove the channels.
8. Plug the unions of the injection pump and injectors to keep dust out.
9. Also block the injection channels to keep dust out.

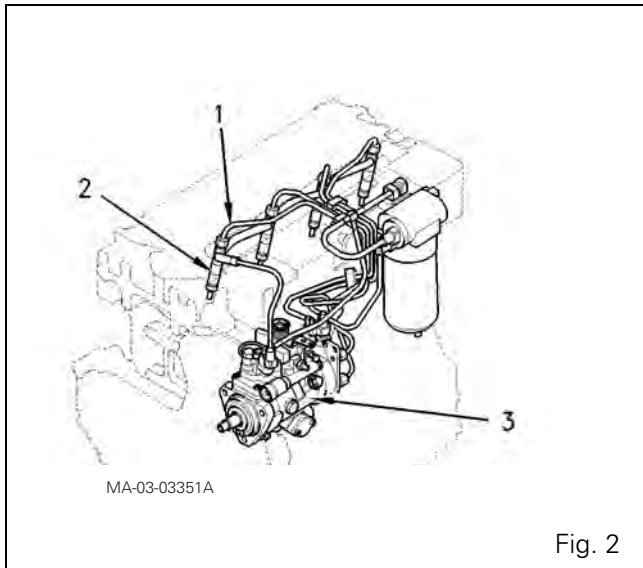
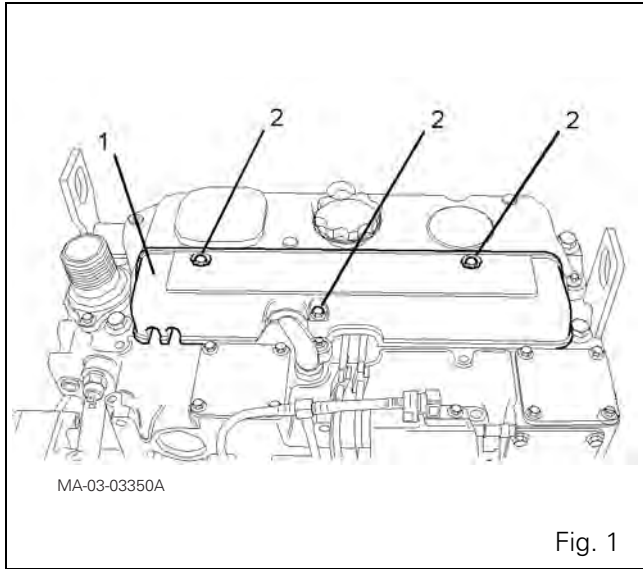

Perkins engine - Disassembling and reassembling

Removing the crankshaft pulley, fan and water pump

10. Loosen the alternator screws.
11. Release the belts by turning the alternator.
12. Take out the three screws (1) and the spacer (2) (Fig. 3).
13. Remove the crankshaft pulley (3) (Fig. 3).
14. Remove the fan. Take off the belts.
15. Drain the cooling system.
16. Loosen and remove the hoses attached to the water pump.
17. Remove the screws (3) from the pump (4) (Fig. 4).
18. If required, gently tap the pump with a plastic hammer in order to release it.
19. Take off the water pump. Take off and discard the seal (2) (Fig. 4).

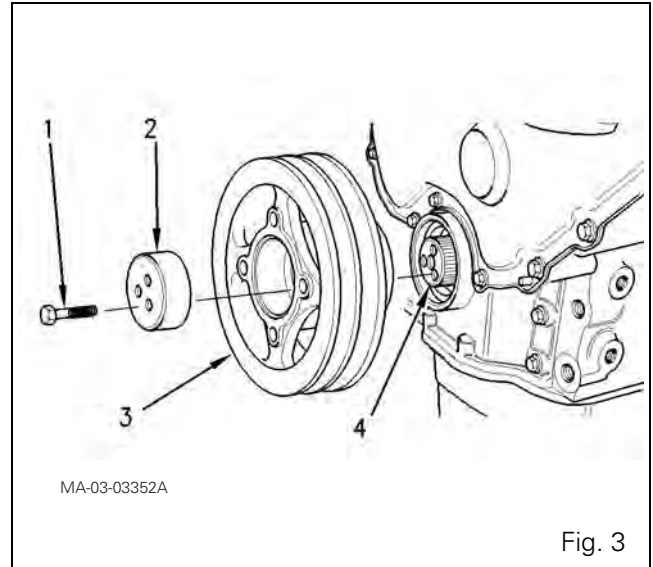

Fig. 3

Removing the front cover plate

20. Remove the screws (3) (4) and (5) from the cover plate (1) (Fig. 5).
- NOTE:** The screws are not identical. Mark them in relation to their holes in order to make reassembly easier.
21. Remove the cover plate (1). Take off and discard the seal (2) (Fig. 5).

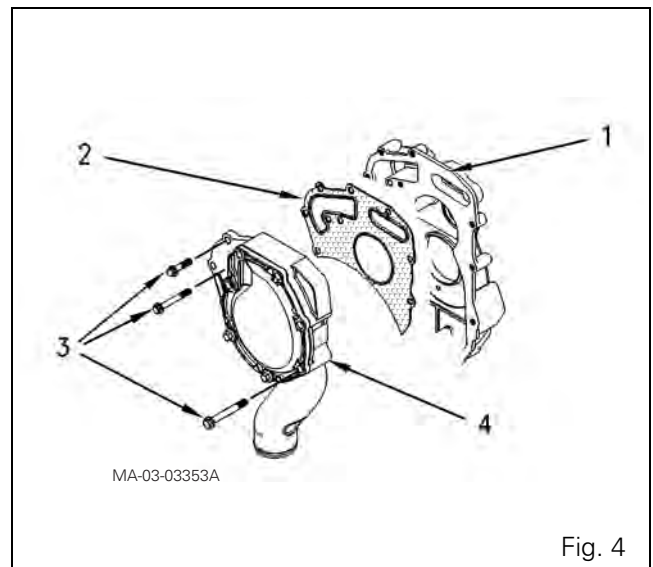

Fig. 4

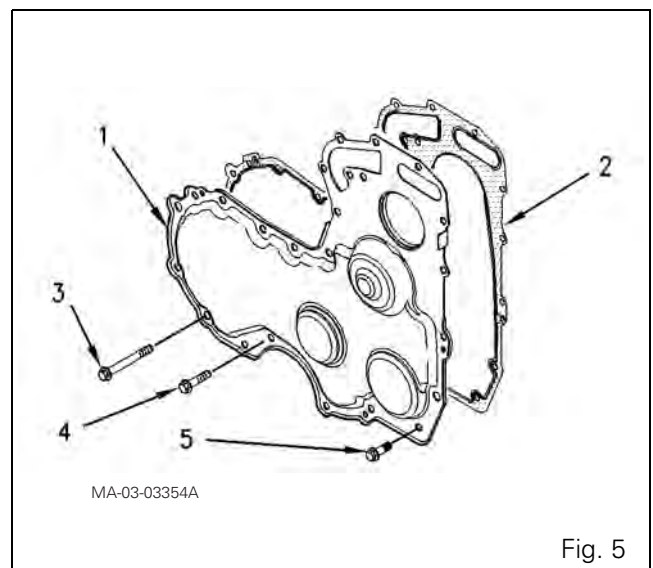

Fig. 5

Perkins engine - Disassembling and reassembling

Refitting fuel injection channels

- 22.** Check the condition of the channels (1) (Fig. 2). Replace those that are defective.
- 23.** Refit the injection channel flanges to hold the channels in place, without tightening.
- 24.** Remove the dustproof plugs from the unions of the pipes and injection pump.
- 25.** Reassemble the unions without tightening on either side of the injection channels.
- 26.** Ensure that the channels fit correctly without being obstructed by other engine parts.
- 27.** Tighten the channel flanges. Check their correct positioning again.
- 28.** Tighten the channel / injector unions to 30 Nm.
- 29.** Tighten the channel / injection pump unions to 30 Nm.
- 30.** Bleed the system.
 - Delphi DP210 pump: bleeding is automatic. Switch on the ignition for approximately 3 minutes. The air should bleed automatically from the system. Do not carry out steps 31 to 34.
 - Bosch VE10 pump: bleeding is not automatic. Perform steps 31 to 34.
- 31.** Switch on the ignition for 3 minutes then switch it off.
- 32.** Loosen the injector unions.
- 33.** Activate the starter until there is no air in the fuel flowing out of the injector unions (no bubbles).
- 34.** Retighten the unions to 30 Nm.
- 35.** Start the engine. Ensure it operates correctly and that there are no leaks.
- 36.** Stop the engine.
- 37.** Clean the internal surfaces of the injector cover.
- 38.** Refit the injector cover (Fig. 1).
- 39.** Refit the screws. Tighten to a torque of 9 Nm.

Perkins engine - Disassembling and reassembling

Refitting the front cover plate

40. Carefully clean all cover plate surfaces and the mating face of the seal on the housing.
41. Position two guide studs in the appropriate holes (6) (Fig. 7). Check for the presence of three dowel pins (7) (Fig. 7) and ensure they are in good condition. Replace them if necessary.
42. Fit the seal (2) (Fig. 6) on the cover plate.
NOTE: The seal is fitted on the cover plate using the three dowel pins (7).
43. Position the cover plate (1) and the seal (2) on the engine sump. Fit screws (3) in holes (8) and screws (5) in holes (9).
44. Take the two guide studs out of the holes (6). Fit the remaining screws (4). Tighten the screws by hand.
45. Refit the water pump before tightening the screws to a torque of 22 Nm.

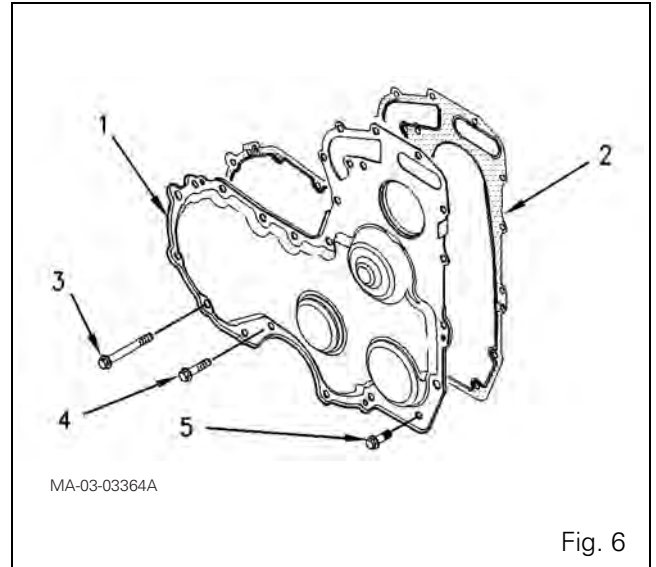

Refitting the crankshaft pulley, fan and water pump

46. Check the condition of the water pump and its drive mechanism.
47. Clean the mating faces of the seals on the pump (4) and the housing (1) (Fig. 8).
48. Install two guide studs (5) on the housing (1) (Fig. 8).
NOTE: Do not apply sealing product to the new seal (2).
49. Fit the new seal (2) on the housing (1).

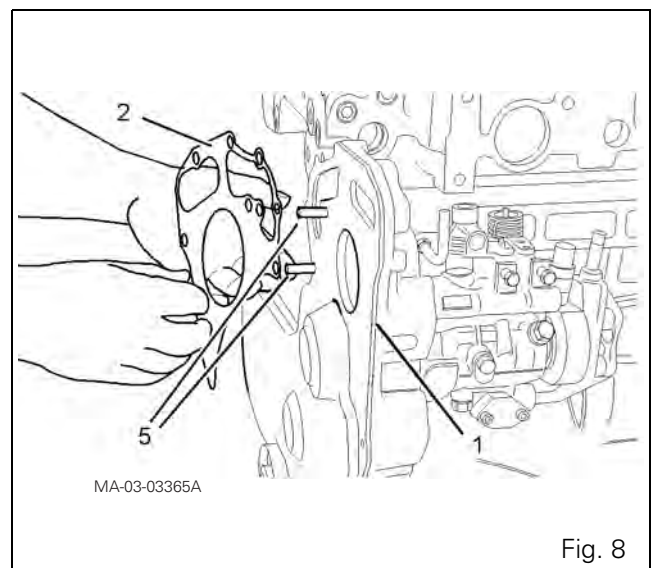
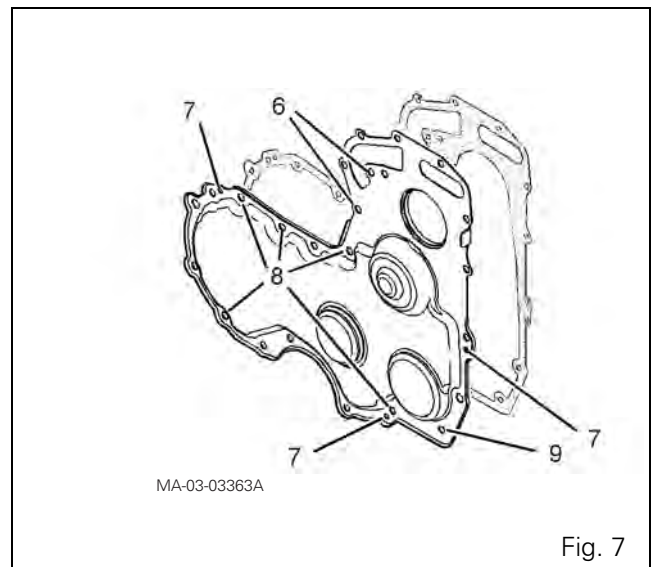

Perkins engine - Disassembling and reassembling

50. Position the water pump (4) on the housing (1) (Fig. 9).
51. Position the water pump tightening screws (3) (Fig. 9). Do not tighten the screws.
52. Remove the guide studs from the housing and refit the last remaining screws (3).
53. Tighten the screws (3) in the order indicated in Fig. 10 to a torque of 22 Nm.
NOTE: Tighten the screws (3) consistently.
54. Fit the hoses removed from the water pump. Tighten the attachment clips.
55. Fill the cooling system.
56. Clean the crankshaft pulley (3) and the spacer (2). Check their condition.
57. Position the pulley (3) on the crankshaft (4).
58. Lightly oil the threads and heads of the screws (1) with clean engine oil.
59. Refit the spacer (2) and screws (1). Tighten the screws consistently to a torque of 115 Nm.
60. Check the tightening again for correct torque.
61. Fit the accessory belts.
62. Refit the fan.
63. Correctly tension the belts by adjusting the alternator. Belt tension is measured at the middle of the longest run and should be 535 N for a new belt and 355 N for a used belt.
64. Tighten the alternator screws to a torque of 22 Nm.

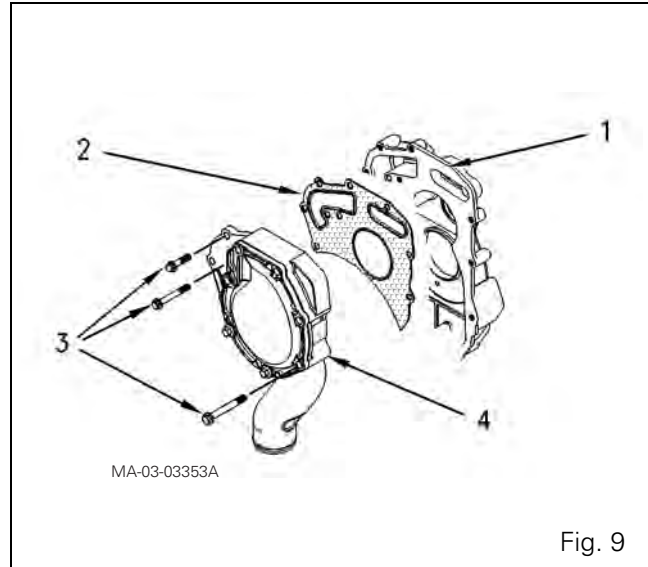

Fig. 9

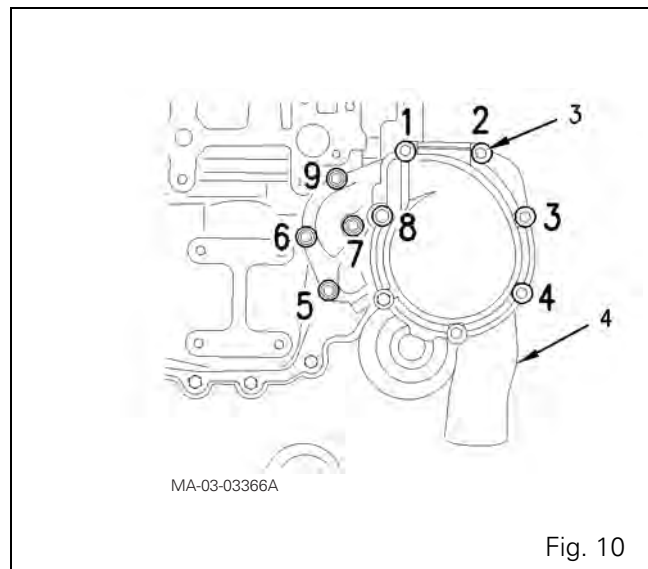

Fig. 10

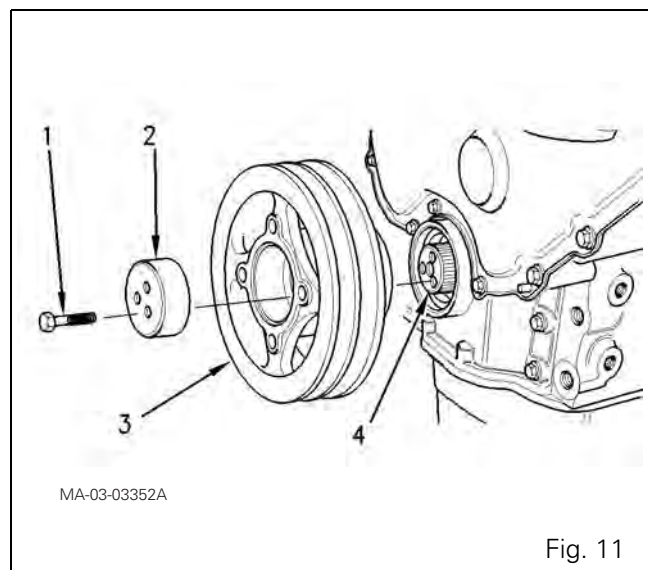

Fig. 11

Perkins engine - Disassembling and reassembling

C . Timing the engine at Top Dead Centre on the first cylinder (4-cylinder engine)

NOTE: The first cylinder is the cylinder furthest from the engine flywheel.

65. Take out the rocker cover and glow plugs.
66. Turn the crankshaft in the normal engine operating direction until the inlet valve of cylinder 4 is slightly open and the exhaust valve of the same cylinder is nearly closed.
67. Slowly turn the crankshaft in the normal engine operating direction to align the hole in the crankshaft with the hole in the engine block. Fit the pin ref. 4224730M1 fully in the hole.
68. Fit the pin ref. 4224757M1 into the hole in the camshaft gear.
69. The engine is now timed at Top Dead Centre on the first piston.

Parts list (Fig. 12)

- 1 Hole for crankshaft timing pin
- 2 Hole for camshaft timing pin

Service tools required		
Reference	Description	Quantity
4224730M1	Crankshaft timing pin	1
4224757M1	Camshaft timing pin	1

These tools are available in the AGCO network from the parts department (see § J).

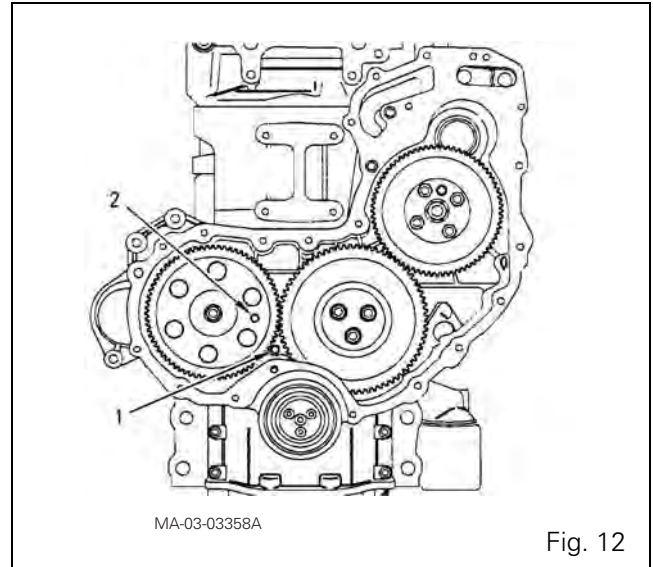

Fig. 12

Perkins engine - Disassembling and reassembling

D . Removing the injection pump (4-cylinder engine)

Delphi DP210 pump

- 70. Take off the adjacent components (see § B).
- 71. Check the position of the first cylinder piston in compression at Top Dead Centre. (see § C).
- 72. Loosen the lock screw (5). Turn the spacer (6) to allow the lock screw (5) to lock the pump pin. Turn the pump pin anti-clockwise until slight resistance is felt (Fig. 13).
- 73. Tighten the lock screw to a torque of 17 Nm.

NOTE: The lock screw (5) must be tightened to prevent the pump pin from turning. The pump pin must not turn when the pump is removed.

- 74. Disconnect the fuel return line (1) (Fig. 13).
- 75. Disconnect the fuel supply line (3).
- 76. Disconnect the connector (2) of the injection timing solenoid (7).
- 77. Remove the nut (8) and retaining washer from the injection pump gear (Fig. 14).
- 78. Extract the pump gear (9) using a suitable puller.
NOTE: Do not try to extract the gear (8) by inserting a lever between the gear and the housing.
- 79. Take out the nut (14) and screw (12) (Fig. 15).
- 80. If necessary, take out the screw (15) and the bracket (11) from the engine block.
- 81. Take out the screws (13) to remove the injection pump.
- 82. Remove the injection pump. Take off and discard the "O" ring (10).

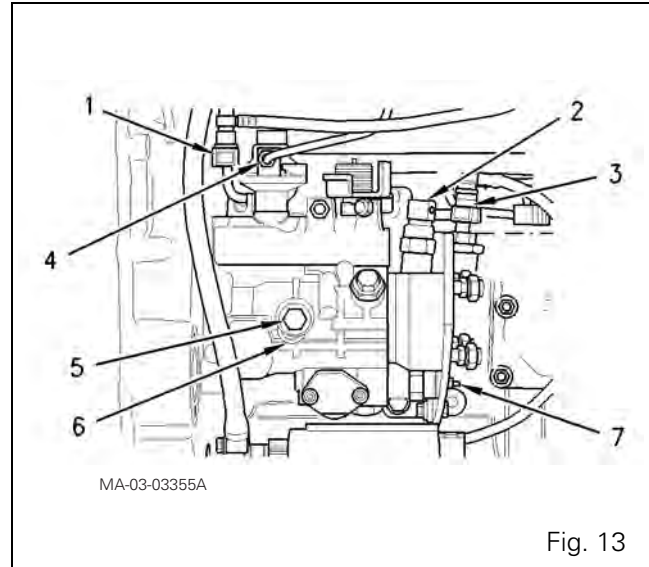

Fig. 13

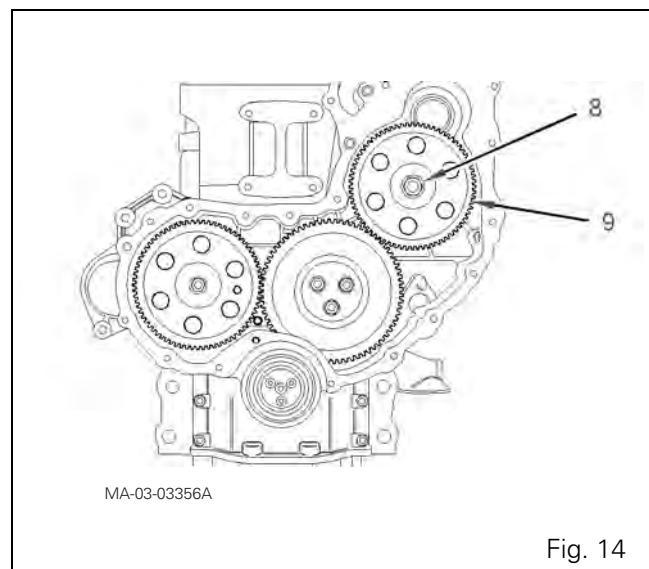

Fig. 14

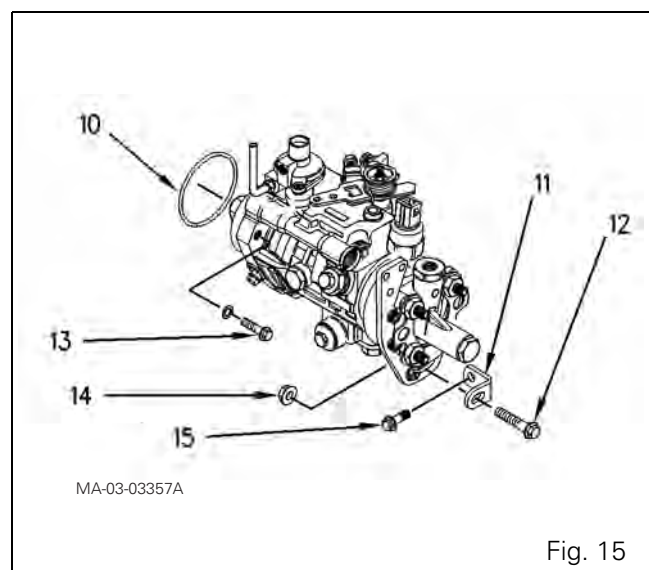

Fig. 15

Perkins engine - Disassembling and reassembling

Bosch VE10 pump

83. Take off the adjacent components (see § B).
84. Check the position of the first cylinder piston in compression at Top Dead Centre. (see § C).
85. Mark and disconnect the fuel pipes (1) and (2) from the injection pump (Fig. 16). Plug the unions to keep dust out of the channels.
86. Disconnect the injection timing system connector (3). Disconnect the engine stop solenoid connector (4) (Fig. 16).
87. Loosen the lock screw (6). Shift the spacer (5) to allow the lock screw (6) to lock the pump pin. Turn the pump pin anti-clockwise until slight resistance is felt (Fig. 17).
88. Tighten the screw to a torque of 31 Nm.

NOTE: The lock screw (6) must be tightened to prevent the pump pin from turning. The pump pin must not turn when the pump is removed.

89. Remove the nut (7) and retaining washer from the injection pump gear (8).
90. Extract the pump gear (9) using a suitable puller.
NOTE: Do not try to extract the gear (8) by inserting a lever between the gear and the housing.
91. Take out the nut (13) and screw (11) (Fig. 18).
92. If necessary, remove the bracket (10) and its screws from the engine block.
93. Take out the screws (12) to remove the injection pump.
94. Remove the injection pump. Take off and discard the "O" ring (9).

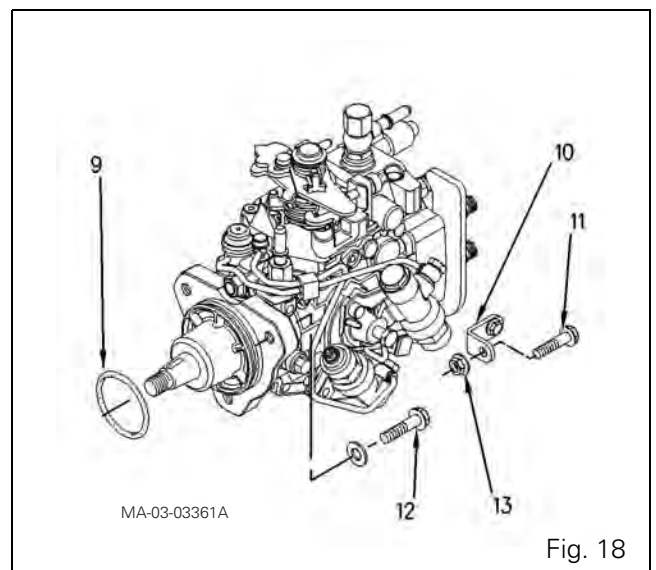
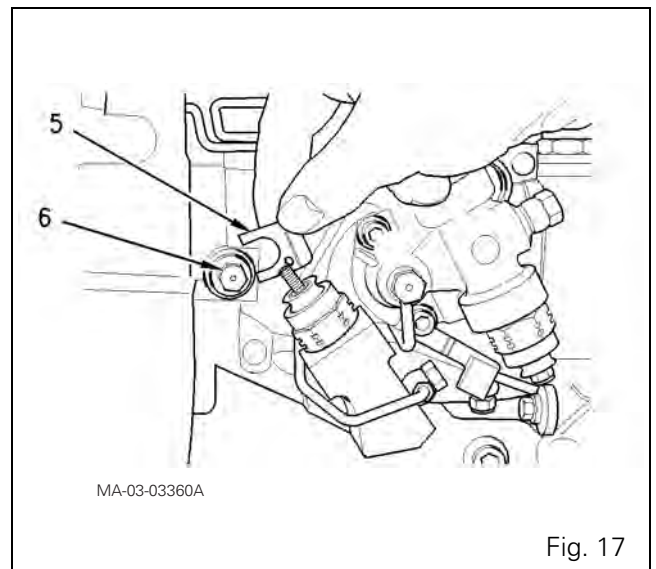
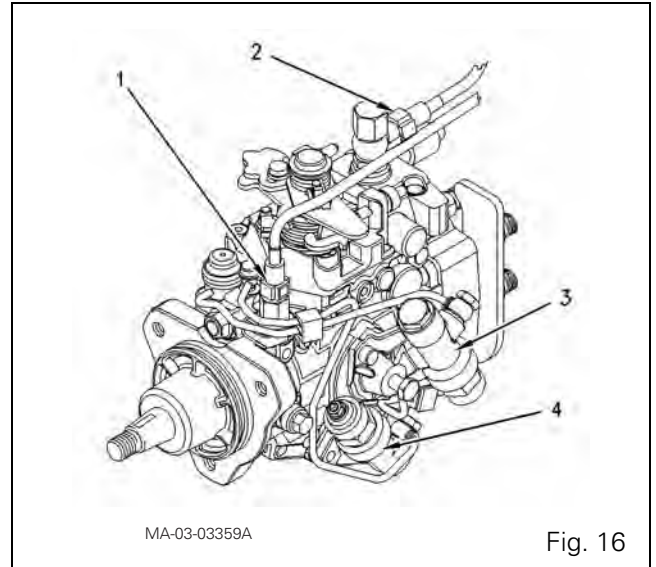

Perkins engine - Disassembling and reassembling

E . Refitting the injection pump (4-cylinder engine)

Delphi DP210 pump

NOTE: The injection pump must be locked in rotation by the lock screw (5) during reassembly. Do not loosen this screw before being instructed to do so.

If the lock screw has been loosened or if the pump shaft has turned, contact a Perkins agent.

95. Check the position of the first cylinder piston in compression at Top Dead Centre. (see § C).

NOTE: Do not lubricate the "O" ring (10) (Fig. 19): it should be dry fitted.

96. Fit a new "O" ring (10) on the injection pump. Position the injection pump on the housing. Refit the screws (13). Tighten the screws to 25 Nm.

97. Refit the screw (15) and bracket (11) if removed. Check that the bracket properly supports the pump alone. Tighten the screw (15) to 44 Nm.

98. Refit the screw (12) and the nut (14).

99. Ensure the contact faces between the pump shaft and injection pump gear are clean. Lubricate the threads of the pump shaft. The nut (8) should turn freely until it reaches the gear.

100. Position the injection pump gear on the pump shaft. Refit the washer and nut (8). Turn the pump gear anti-clockwise until there is no backlash. Tighten the nut to a torque of 24 Nm.

101. Reconnect all electrical connectors to the pump.

102. Remove all dustproof plugs and ensure the channels and unions are clean.

103. Refit the previously removed fuel channels (1) (3) and (4) (Fig. 20).

104. Loosen the lock screw (5). Move the spacer (6) so that it no longer blocks the pump pin by tightening the screw (5). Tighten the screw to a torque of 12 Nm.

NOTE: The spacer (6) must be correctly positioned and the screw (5) correctly tightened to prevent contact between the injection pump shaft and the screw (5).

105. Tighten the nut (8) to a torque of 88 Nm.

106. Reassemble the adjacent components (injection channels, front cover plate, fan, belts, crankshaft pulley) (see § B).

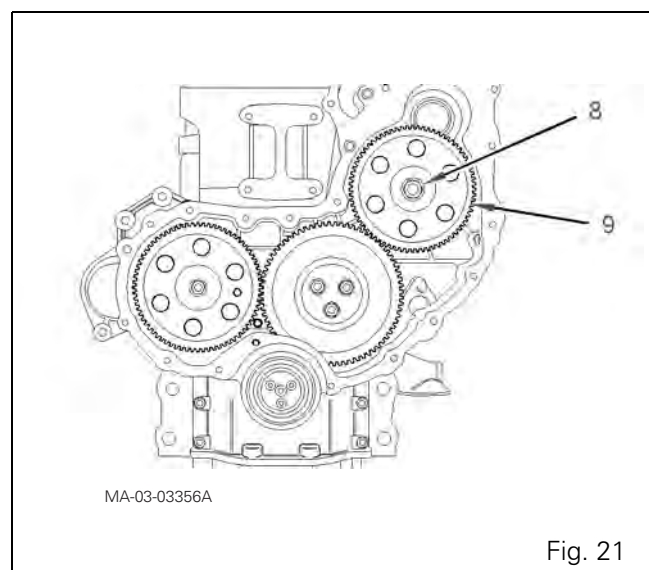
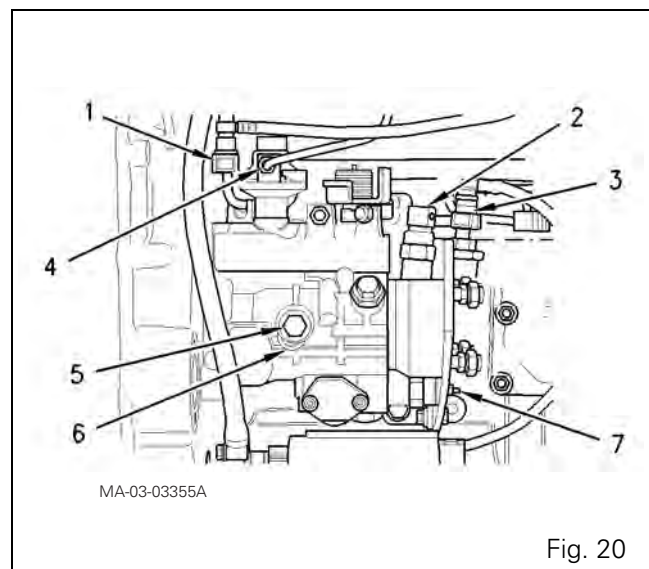
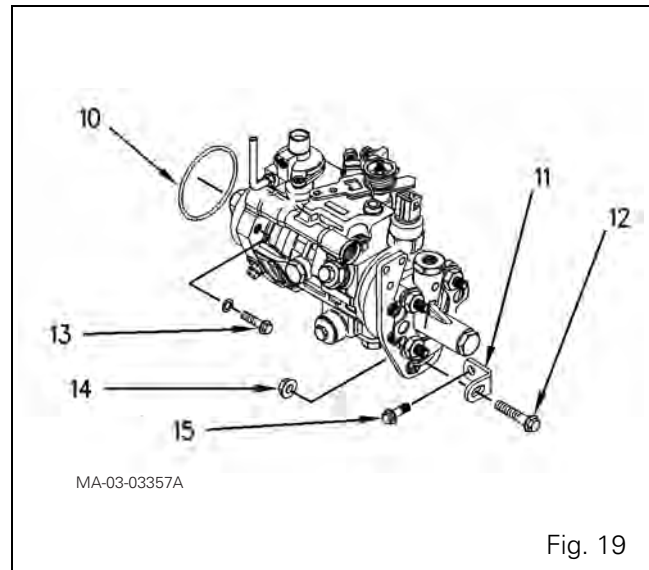

Perkins engine - Disassembling and reassembling

Bosch VE10 pump

NOTE: The injection pump must be locked in rotation by the lock screw (6) during reassembly. Do not loosen this screw before being instructed to do so.

If the lock screw has been loosened or if the pump shaft has turned, contact a Perkins agent.

107. Check the position of the first cylinder piston in compression at Top Dead Centre. (see § C).
108. Lightly lubricate a new "O" ring (9) with silicone oil. Fit the new seal (9) to the pump. Position the injection pump on the housing. Refit the screws (12). Tighten the screws to 25 Nm (Fig. 22).
109. Refit the screw and bracket (10) if removed. Check that the bracket properly supports the pump alone. Tighten the screw to a torque of 44 Nm.
110. Refit the screw (11) and the nut (13).
111. Ensure the contact faces between the pump shaft and injection pump gear are clean. Lubricate the threads of the pump shaft. The nut (7) should turn freely until it reaches the gear (8) (Fig. 23).
112. Position the injection pump gear on the pump shaft. Refit the washer and nut (7). Turn the pump gear anti-clockwise until there is no backlash. Tighten the nut to a torque of 24 Nm.
113. Reconnect all electrical connectors to the pump (Fig. 24).
114. Remove all dustproof plugs and ensure the channels and unions are clean.
115. Refit the previously removed fuel channels (1) (2) (Fig. 24).
116. Loosen the lock screw (6). Move the spacer (5) so that it no longer blocks the pump pin by tightening the screw (6). Tighten the screw to a torque of 12 Nm.
NOTE: The spacer (5) must be correctly positioned and the screw (6) correctly tightened to prevent contact between the injection pump shaft and the screw (6).
117. Tighten the nut (7) to a torque of 88 Nm (Fig. 23).
118. Reassemble the adjacent components (injection channels, front cover plate, fan, belts, crankshaft pulley) (see § B).

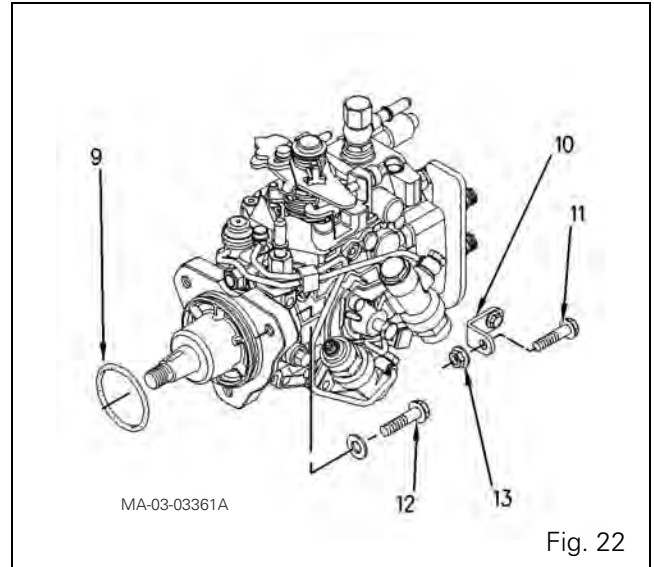

Fig. 22

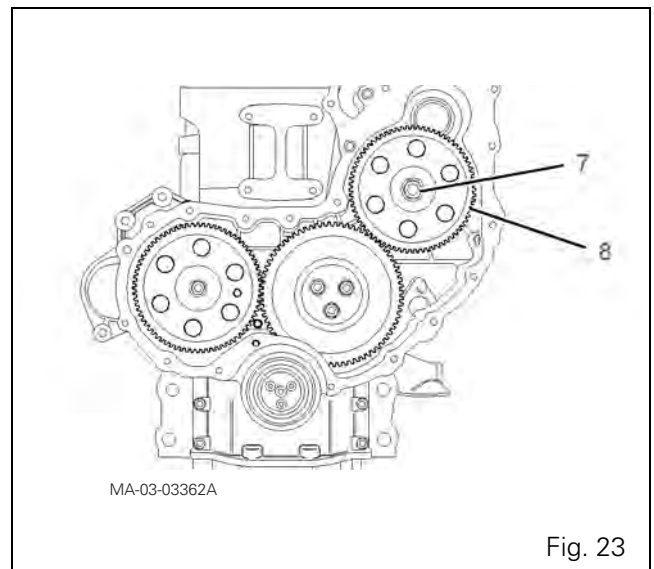

Fig. 23

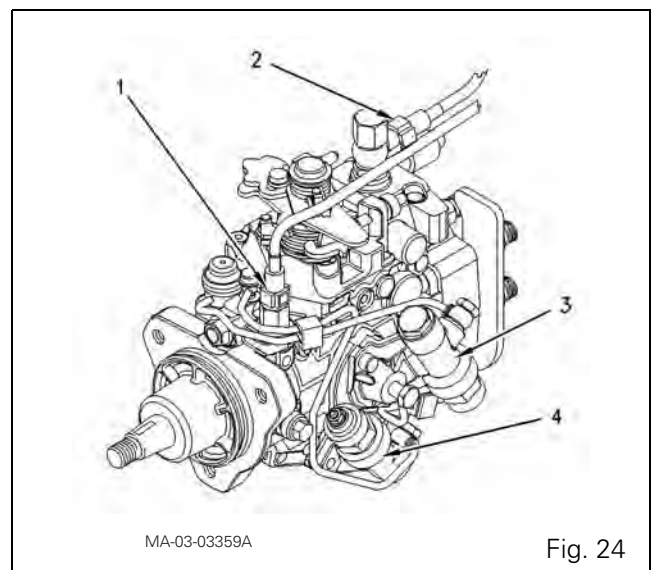

Fig. 24

Perkins engine - Disassembling and reassembling

F . Removing and refitting adjacent components (6-cylinder engine)

Removing fuel injection channels

- 119. Remove the breather from the housing.
- 120. Loosen the clips and take off the hose (1) (Fig. 25).
- 121. Loosen the clips and take off the hose (5) (Fig. 25).
- 122. Remove the screws (2) and the breather (4) from the support (3) (Fig. 25).
- 123. If required, take out the screws attaching the breather support to the engine.
- 124. If required, loosen the nut (8) and remove the valve (6) from the elbow union (9). Remove the elbow union (9) from the adapter (7). Remove the adapter (7) from the engine block.

NOTE: Make indelible marks on the injection channels to make reassembly easier.

- 125. Remove the low pressure injection channels.
- 126. Disconnect the injection channels (1) at the injectors (2).
- 127. Disconnect the injection channels (1) at the injection pump (2).
- 128. Remove the injection channels (1).

NOTE: Plug the pipe unions to keep dust out.

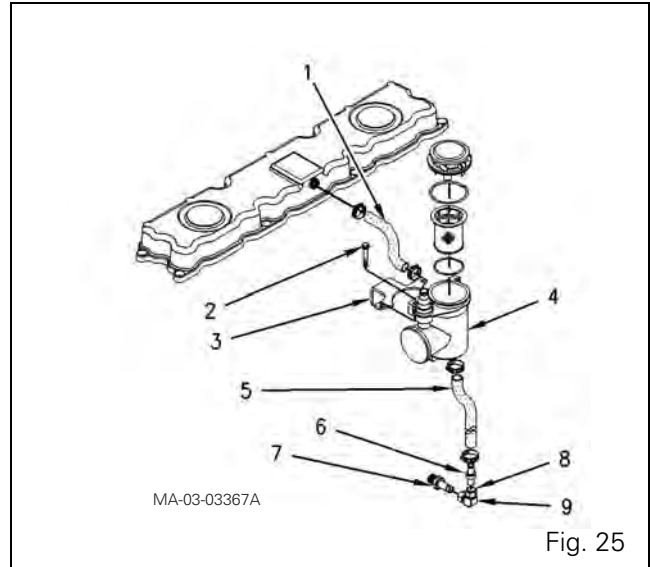

Perkins engine - Disassembling and reassembling

Removing the water pump

- 129.** Drain the coolant into a suitable container for storage or to discard.
- 130.** Loosen the clips then remove the inlet hose of the water pump (2).
- 131.** Take out the two screws (1) (Fig. 26) and the eight screws (3) (Fig. 26) that attach the water pump to the front cover plate.
- 132.** Gently tap the pump with a plastic hammer in order to release it.
- 133.** Remove the water pump and discard the seal.

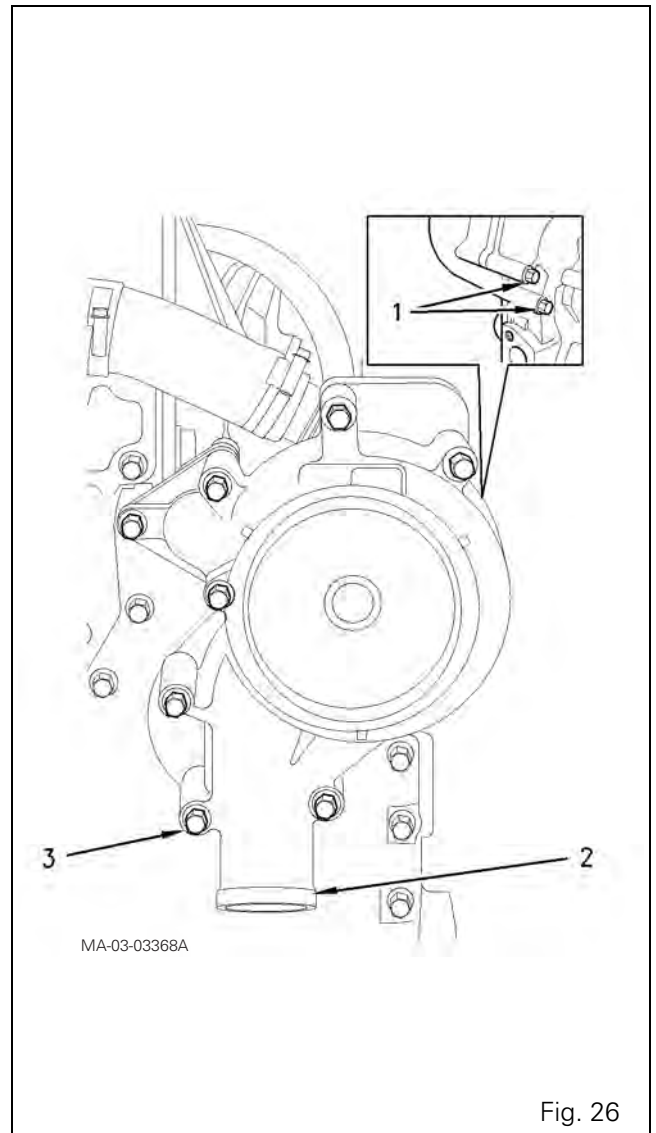

Perkins engine - Disassembling and reassembling

Refitting fuel injection channels

134. Assemble the injection channels (1).
135. Connect the injection channels at the injectors and at the injection pump.
136. Tighten unions to a torque of 28 Nm.
137. Fit the low pressure injection channels.
138. Refit the breather of the housing (Fig. 27).
139. Fit the adapter (7) in the engine block. Tighten to a torque of 30 Nm.
140. Apply threadlock compound to the thread of the valve (6) in the elbow union (9). Tighten the nut (8) by hand. Tighten the nut by an additional ¼ turn.
141. Position the support (3) on the engine block. Fit the screws and tighten to a torque of 44 Nm.
142. Fit the breather (4) on the support (3) and fit the screws (2). Tighten the screws (2) to 9 Nm.
143. Fit the hose (1) and tighten the clips. Fit the hose (5) and tighten the clips.
144. Bleed the fuel system.
145. Loosen the injection pump nut (2) (Fig. 28).
146. Activate the priming pump until fuel flow is level with the nut (2).
147. Tighten the nut (2) to a torque of 23 Nm.
148. Loosen the unions (4) of the injectors (fig).
149. Activate the starter until fuel flows out of the channels.
NOTE: The injection pump, battery and starter can be damaged by excessive use of the starter to bleed the air from the system.
150. Tighten unions to a torque of 22 Nm.
151. The engine is ready to start. Run the engine at idle speed for at least 5 minutes as soon as the air has been expelled from the fuel system.

NOTE: Running the engine for this time helps ensure that the pump is totally free of air. This protects internal parts of the pump from damage caused by metal-to-metal contact. If the engine stops or misfires, check that there is no air in the fuel system. If air is present in the fuel system, search for a leak in the low pressure system.

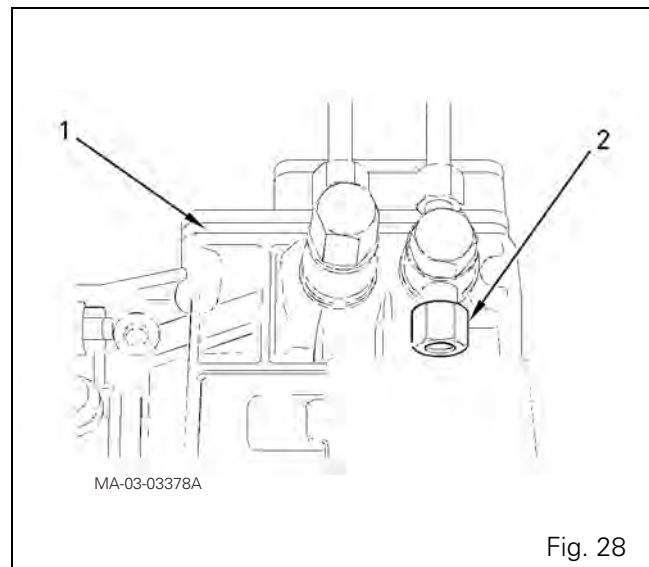
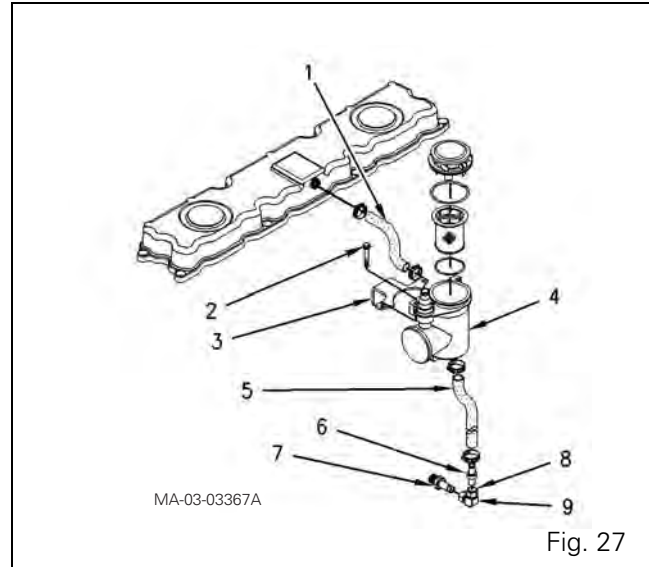

Perkins engine - Disassembling and reassembling

Refitting the water pump

152. Look for signs of wear or damage on the water pump drive gear. If necessary, replace the drive gear.

IMPORTANT: Do not use sealing compound on the water pump seal.

153. Clean the seals of the water pump (2) and the front housing (1). Clean the lug (3) on the water pump. Fit a new seal to the water pump (Fig. 29).

154. Fit the water pump and seal to the front housing (1). Check that the water pump gear and the injection pump gear are meshed.

155. Fit the eight screws (5) attaching the water pump to the front housing. Fit the two pressure screws (4) to the rear of the front housing. Tighten all screws to a torque of 22 Nm (Fig. 30).

156. Fit the hose to the water pump inlet (6). Tighten the clips.

157. Fill the cooling system.

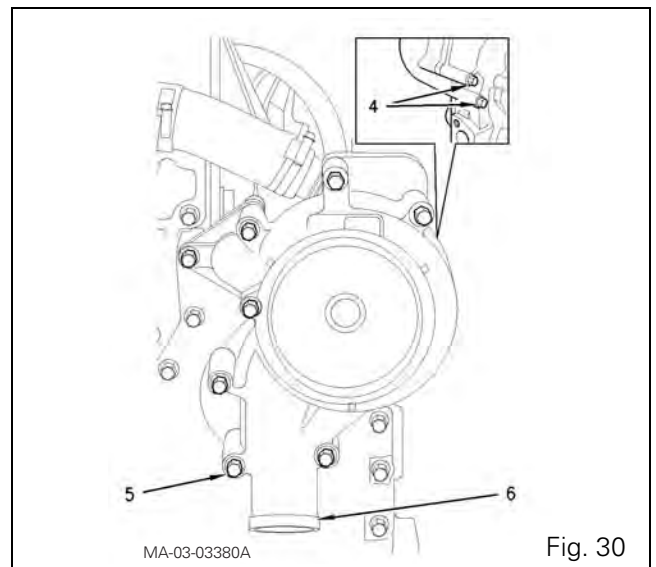
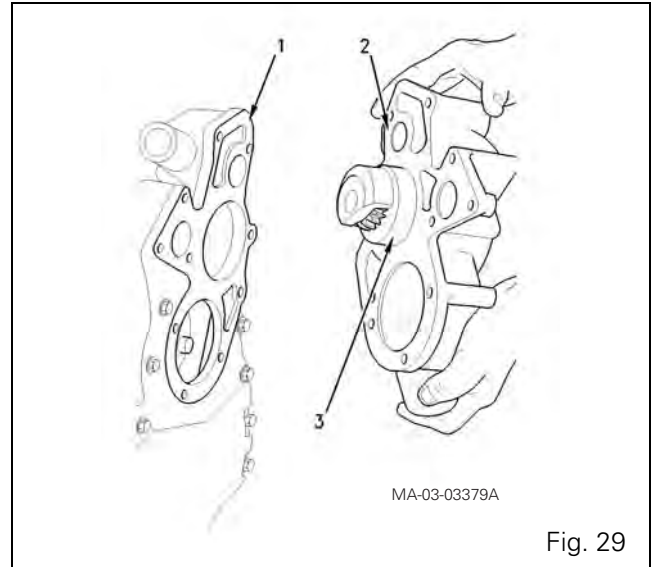

Perkins engine - Disassembling and reassembling

G . Timing the engine (6-cylinder engine)

In order to disassemble the pump, the engine must be set at 4° after TDC in the compression travel of the first cylinder (the cylinder furthest from the engine flywheel).

158. Using a dial gauge, position the first cylinder piston at TDC in the compression phase.
159. Remove the injector of the second cylinder. Loosen the threaded nut (2) on the injector (3) (Fig. 31).
160. Fit a plastic plug (1) to cover the fuel inlet connection on the injector.
161. Remove the injector (2) from the cylinder head.
162. Remove the seat washer (4).
- NOTE:** If the original washer is not removed, the injector will protrude incorrectly when a new seat washer is fitted.
163. Check the injector bore and seat.
164. Position tool ref. 4224787M1 into the injector bore (Fig. 32).
This tool is available in the AGCO network (see § J).

Parts list (Fig. 32)

- (1) Nut
- (2) Alignment pin
- (3) Main body
- (4) Sensor

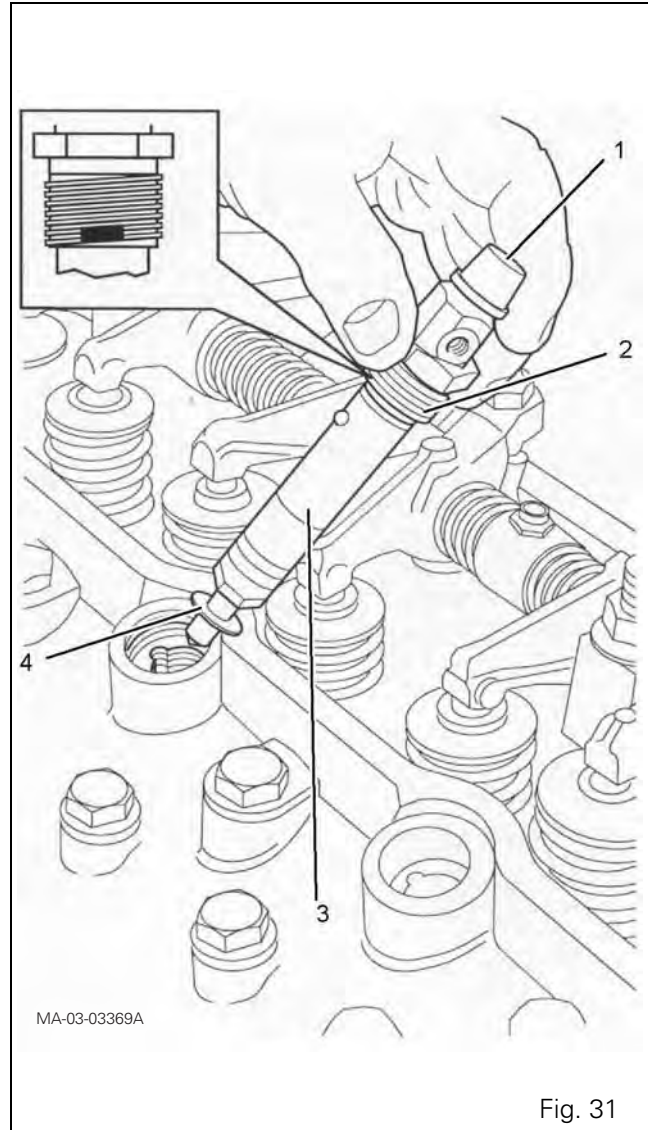

Fig. 31

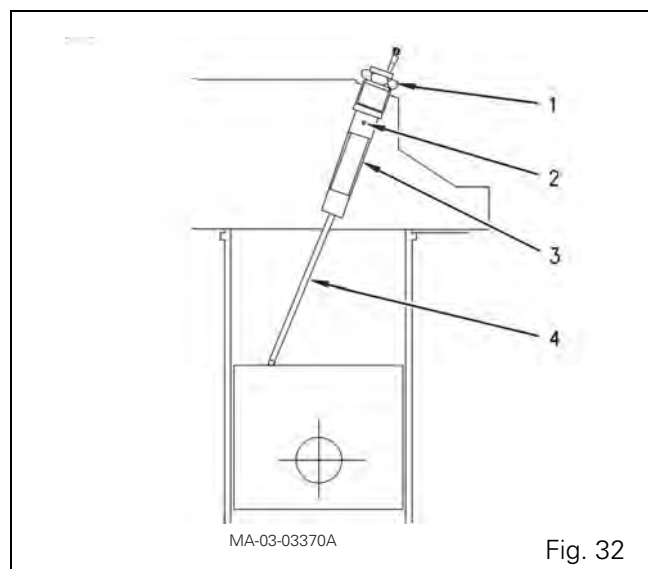

Fig. 32

Perkins engine - Disassembling and reassembling

165. Align the alignment pin (2) of the main body (3) in the opening of the fuel injector hole.
166. Position the main body (3) in the fuel injector hole and fit the nut (1).
167. Apply clean engine oil to the sensor (4).
168. Insert the sensor (4) into the main body (3). Slowly lower the sensor (4) onto the piston crown.

Parts list (Fig. 33)

- (5) Upper part of main body
- (6) Sensor aligned on the main body
- (7) Machined face of sensor

169. Turn the crankshaft clockwise until the machined face of the sensor (7) is aligned on the upper part of the main body (5).
170. The piston of the first cylinder is now 4° after TDC in compression travel.

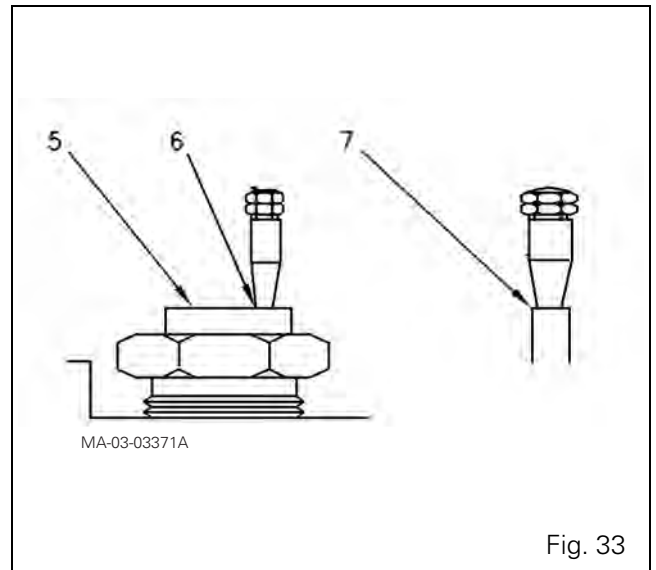

Final step, reassembling the injector

After refitting the injection pump, remove the engine timing tools.

Refit the removed injectors.

171. Carefully clean the threads of the threaded nut (2) on the injector and in the cylinder head (Fig. 31).
172. Fit a new seat washer (5) in recess of the cylinder head.
173. Apply a 2 mm (approx.) bead of universal sealing compound on the two first threads (7) of the threaded nut (2) on the injector (3).
174. Position the injector (3) in the cylinder head. Check that the injector interlock ball (6) is correctly aligned with the cylinder head slot (4) (Fig. 31).
175. Carefully tighten the threaded nut (2) on the injector to a torque of 40 Nm. Remove any surplus universal sealing compound from the injector.

NOTE: Do not turn the injector after assembly. The sealing compound might break. A broken seal can cause water to leak and injector corrosion.

Perkins engine - Disassembling and reassembling

H . Removing the injection pump (6-cylinder engine)

176. Check the position of the first cylinder piston is at TDC in compression travel (see § G).
177. Insert the timing pin ref. PD245 into the hole (3) (Fig. 34) of the injection pump gear and the hub slot (2). Push the timing pin fully into the hole (3) of the injection pump body. If the pin can be fully inserted, the injection pump timing is correct. There should be no resistance when the timing pin is inserted.
178. Disconnect the electrical connector (5) (Fig. 35). Pull it to disconnect its locking mechanism. Take care not to damage the connector pins.
179. Take out the four screws (4) (Fig. 34) and the hardened washers. Remove the injection pump gear from the injection pump hub.
180. Remove the nut and screw (9) (Fig. 36) from the pump support.
181. Remove the three nuts from the flanged studs and injection pump. If the nuts are not accessible, use wrench ref. PD239 from Bosch.
182. Discard the injection pump "O" ring.

NOTE: Do not turn the crankshaft when the pump is not fitted to the engine.

Tools ref. PD245 and ref. PD239 are available in the AGCO network (see § J).

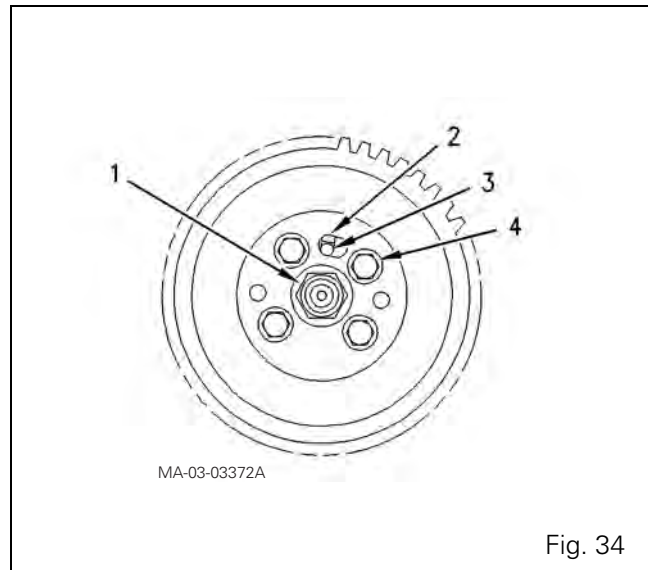

Fig. 34

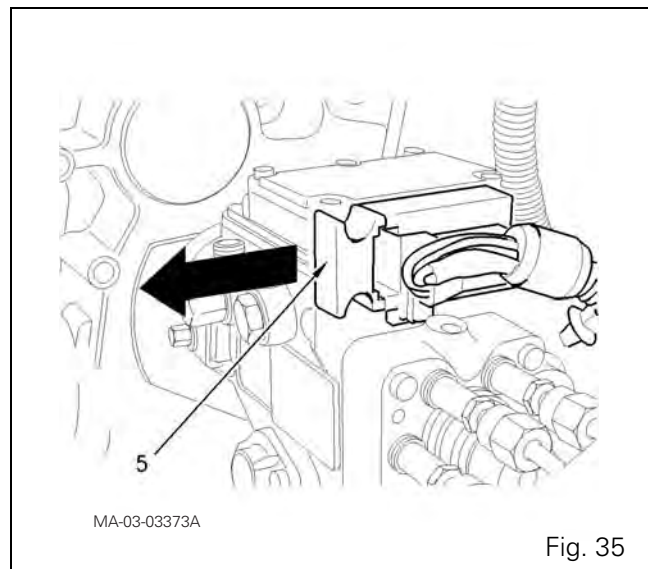

Fig. 35

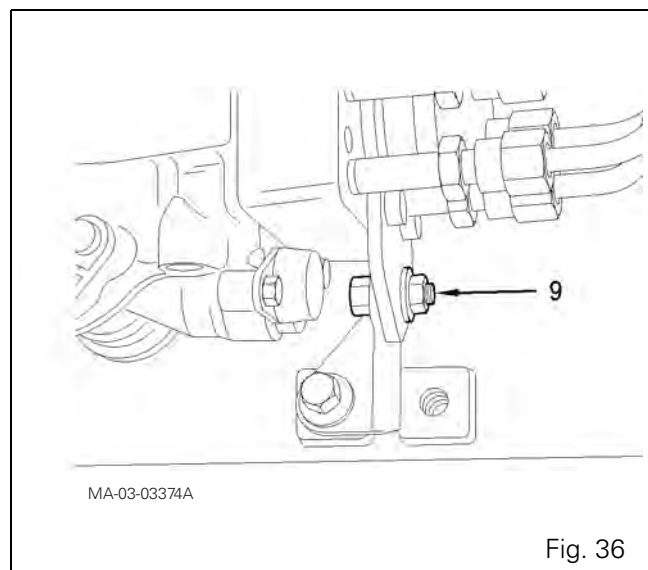

Fig. 36

I . Refitting the injection pump (6-cylinder engine)

183. Check the position of the first cylinder piston is at TDC in compression travel (see § G).

NOTE: A new injection pump may be supplied with the pump pin in locked position.

The injection pump pin should not be turned without the spacer (2) (Fig. 37) in position under the lock screw (1). Before turning the crankshaft or assembling the injection pump, position the spacer (2) under the lock screw (1) to ensure that the pump pin is not locked.

184. Fit a new "O" ring (3) (Fig. 37) to the injection pump flange.

185. Lightly lubricate the "O" ring (3) with clean engine oil. Fit the timing pin in the injection pump. Fit the pump on the three studs. Fit the three nuts on the studs. Tighten to a torque of 22 Nm.

186. Assemble the nut and screw (5) (Fig. 38) of the injection pump support.

NOTE: When the support is assembled, check that no force is applied to the injection pump.

187. Tighten the nut and screw (5) of the pump support to a torque of 22 Nm.

188. Assemble the injection pump gear on the pump hub. To prevent any backlash, check that the four pressure screws (6) (Fig. 39) are centred in the gear slots. Fit the four injection pump screws (6) without tightening.

NOTE: The injection pump gear must be assembled on the pump before turning the crankshaft.

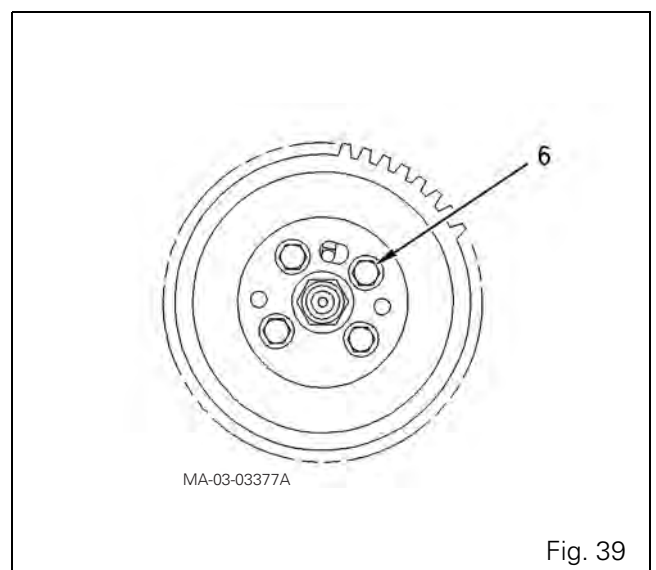
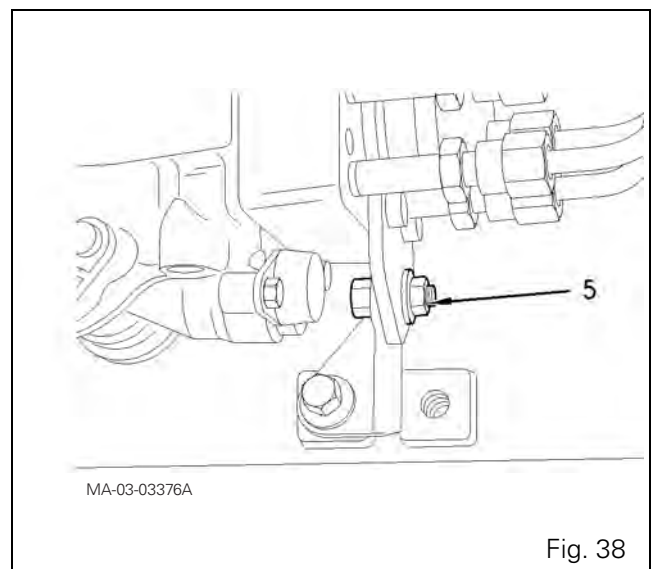
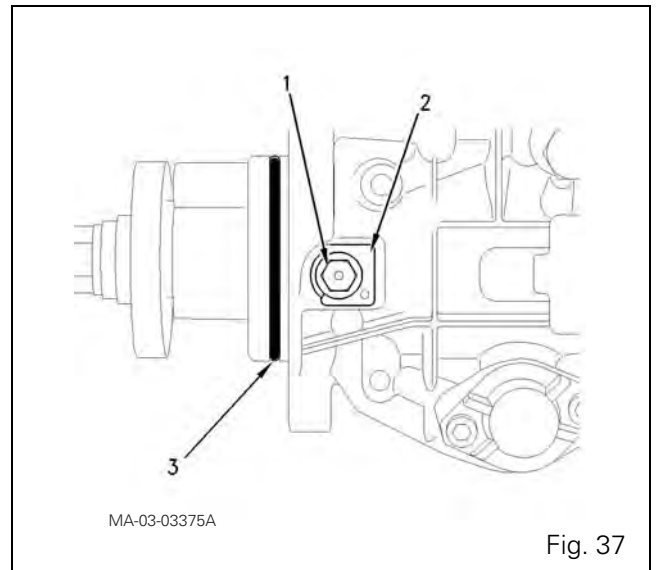

Perkins engine - Disassembling and reassembling

- 189.** Check the backlash between the layshaft gear and the injection pump gear. To prevent any backlash, turn the pump gear anti-clockwise. Do not turn the crankshaft or the injection pump shaft. Tighten the four screws of the pump gear to a torque of 28 Nm.
- 190.** Take out the timing pin.
- 191.** Fit the electrical connector.
- 192.** Reassemble the previously removed adjacent components (injection channels, breather, water pump, injector) (see § F and § G).

Perkins engine - Disassembling and reassembling

J . Service tools

6-cylinder 1106 engine tools

4224787M1: Timing tool for 6-cylinder engine (Fig. 40)

PD245: Timing pin for Bosch VP30 injection pump (Fig. 41)

PD239: Injection pump removal wrench (Fig. 42)

These tools are available from the AGCO Technical Documentation department.

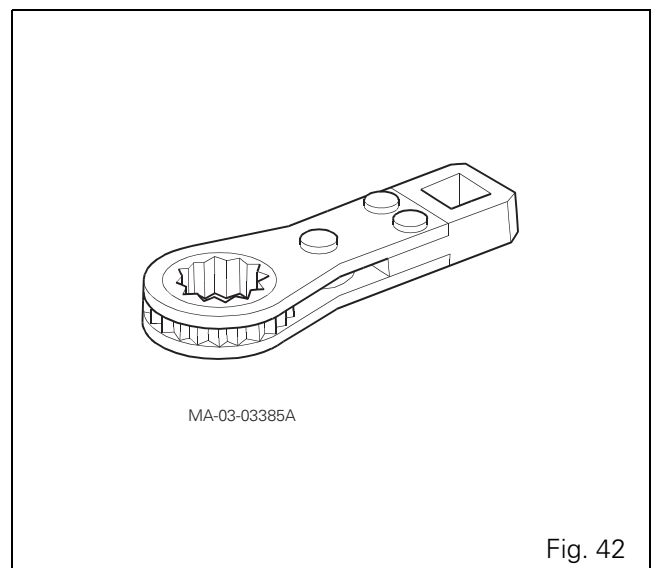
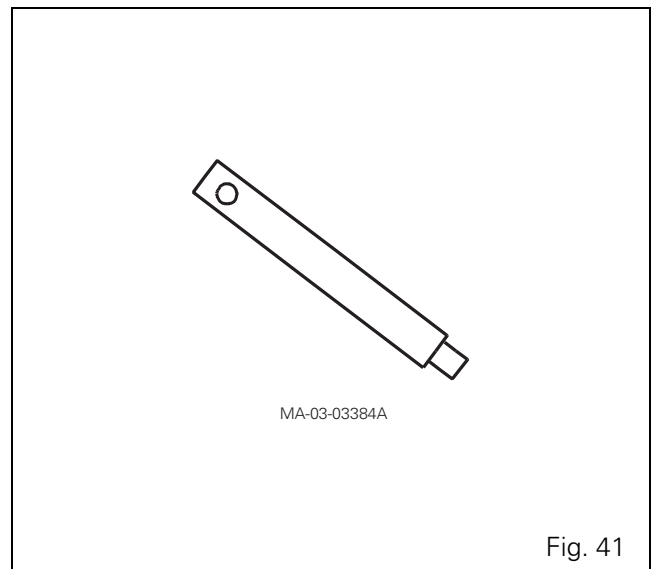
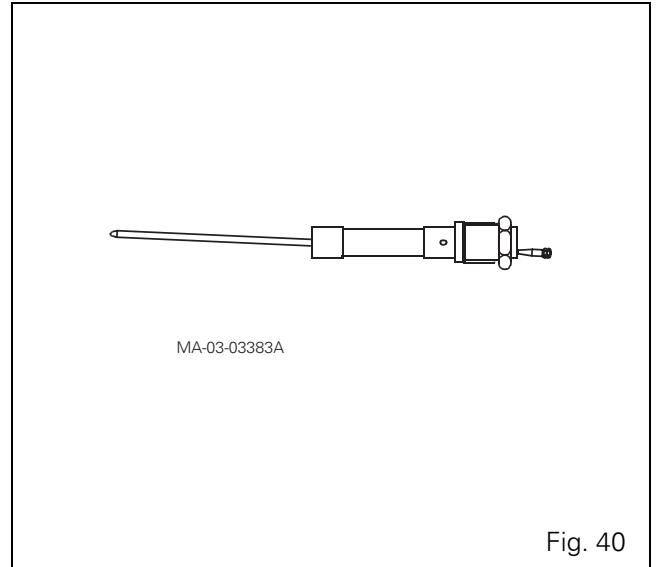

Perkins engine - Disassembling and reassembling

4-cylinder 1104 engine tools

4224730M1: Crankshaft timing pin for 4-cylinder engine (Fig. 43)

4224757M1: Camshaft timing pin for 4-cylinder engine (Fig. 44)

These tools are available from the AGCO network parts department.

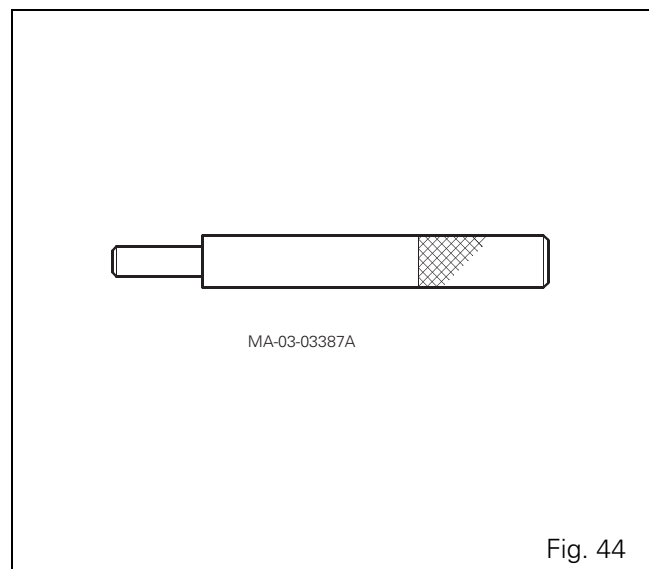
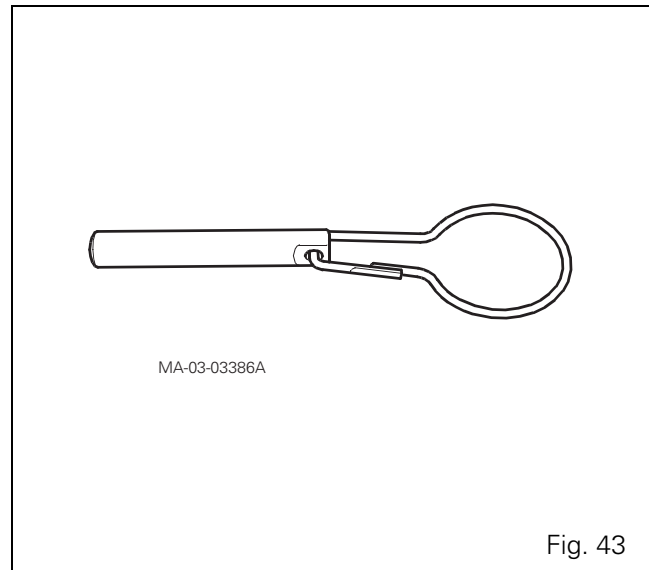

3B10- SISU engine - General

CONTENTS

A . Introduction 3

B . Specifications and standards relating to fuel, oil and coolant 3

C . Main specifications 4

A . Introduction

This section only provides general information about Perkins engines used on this tractor series.

B . Specifications and standards relating to fuel, oil and coolant

The engines fitted on this tractor series comply with standards concerning emissions imposed by the authorities (EU97/68/EC Stage 2 and EPA 40 CFR 89 Tier 2).

Fluids used in these engines must be of the correct quality and the servicing schedule must be observed to keep pollution emission levels low and to maintain the tractor's performance throughout its service life.

Fuel quality:

The fuel must conform to the DIN EN 590 standard and the following specifications:

Density (at 15°C): 0.82 to 0.84 kg/dm³

Viscosity (at 40°C): 2 to 4.5 mm²/sec

Cetane Index: min 51

Sulphur content: max 0.005 p-%

Water content: max 200 mg/kg

Oil quality:

The oil used must conform to the API CH-4 standard.

Coolant quality:

The coolant used must comply with standard ASTM D 3306. It must be composed of pure water and ethylene/propylene glycol antifreeze agent in the following proportions:

40 - 60% water

40 - 60% antifreeze

The ideal ratio is around 50% water to 50% antifreeze.

SISU engine - General

C . Main specifications

Model	5470
Engine type	44 DTA
SISU engine list no.	V832661108
No. of cylinders	4
Bore	108
Stroke	120
Cubic capacity	4.4
Compression ratio	17.25/1
Compression pressure (kPa)	2000/3500
Permissible compression deviation between cylinders (kPa)	350
Output at 2200 rpm (kw) ISO	121 (90)
Maximum torque (Nm/lbf.ft)	500
at speed (rpm)	1400
Idle speed	950
Nominal speed	2200
Maximum speed at no load	2385 +/-30
Injection pump	
Brand and type	Bosch VE
Rotation	Clockwise
Static timing angle (degrees)	5°
Engine position	TDC
Engine check angle (degrees)	pin
Pump check angle (degrees)	pin
Firing order	1, 2, 4, 3
Injectors	
Brand	Bosch
New and servicing setting (bar)	278
Aspiration system	
Aspiration system	Turbo + Intercooler Air/Air
Type	
Valve spring	single
Valve seat insert (inlet/exhaust)	yes
Valve angle	0.46°/0.31°
Inlet/exhaust valve clearance (mm)	0.35/0.35
Oil cooler	yes
No. of thermostats	1
Opening temperature (start/full)	79°C/83°C
Piston cooling nozzle	yes
Oil filter	1
Fuel filter	1 (+ 1 prefilter)

SISU engine - General

Model	5470 SA (Orchard cab)
Engine type	44 DTA
SISU engine list no.	V832661417
No. of cylinders	4
Bore	108
Stroke	120
Cubic capacity	4.4
Compression ratio	17.25/1
Compression pressure (kPa)	2000/3500
Permissible compression deviation between cylinders (kPa)	350
Output at 2200 rpm (kw) ISO	106 (79)
Maximum torque (Nm/lbf.ft)	500
at speed (rpm)	1400
Idle speed	950
Nominal speed	2200
Maximum speed at no load	2385 +/-30
Injection pump	
Brand and type	Lucas DP210
Rotation	Clockwise
Static timing angle (degrees)	4°
Engine position	TDC
Engine check angle (degrees)	pin
Pump check angle (degrees)	pin
Firing order	1, 2, 4, 3
Injectors	
Brand	Bosch
New and servicing setting (bar)	278
Aspiration system	Turbo + Wastegate + Intercooler air/air
Type	Garrett GT35
Valve spring	single
Valve seat insert (inlet/exhaust)	yes
Valve angle	0.46°/0.31°
Inlet/exhaust valve clearance (mm)	0.35/0.35
Oil cooler	yes
No. of thermostats	1
Opening temperature (start/full)	79°C/83°C
Piston cooling nozzle	yes
Oil filter	1
Fuel filter	1 (+ 1 prefilter)

SISU engine - General

Model	5475 SA (Orchard cab)
Engine type	44 DTA
SISU engine list no.	V832661418
No. of cylinders	4
Bore	108
Stroke	120
Cubic capacity	4.4
Compression ratio	17.25/1
Compression pressure (kPa)	2000/3500
Permissible compression deviation between cylinders (kPa)	350
Output at 2200 rpm (kw) ISO	116 (86.5)
Maximum torque (Nm/lbf.ft) at speed (rpm)	540 1400
Idle speed	950
Nominal speed	2200
Maximum speed at no load	2385 +/-30
Injection pump	
Brand and type	Lucas DP210
Rotation	Clockwise
Static timing angle (degrees)	4°
Engine position	TDC
Engine check angle (degrees)	pin
Pump check angle (degrees)	pin
Firing order	1, 2, 4, 3
Injectors	
Brand	Bosch
New and servicing setting (bar)	278
Aspiration system	
Aspiration system	Turbo + Wastegate + Intercooler air/air
Type	Garrett GT35
Valve spring	single
Valve seat insert (inlet/exhaust)	yes
Valve angle	0.46°/0.31°
Inlet/exhaust valve clearance (mm)	0.35/0.35
Oil cooler	yes
No. of thermostats	1
Opening temperature (start/full)	79°C/83°C
Piston cooling nozzle	yes
Oil filter	1
Fuel filter	1 (+ 1 prefilter)