

# **WORKSHOP SERVICE MANUAL**

## **CONTENTS**

- 1 - Introduction - Specifications
- 2 - Splitting the tractor
- 3 - Engine and equipment
- 4 - Clutch
- 5 - Gearbox
- 6 - Rear axle
- 7 - Power Take Off
- 8 - Front axle 2 and 4WD
- 9 - Hydraulics
- 10 - Electrical equipment
- 11 - Electronics
- 12 - Cab and Equipment
- 13 - Accessories
- 14 - Service Tools



# **1 . INTRODUCTION**

## **Contents**

**1 A01 INTRODUCTION**





## **Introduction**

### *1 A01 Introduction*

#### CONTENTS

<b>A.</b>	<b>Using the manual</b> _____	<b>2</b>
<b>B.</b>	<b>Specifications</b> _____	<b>3</b>
<b>C.</b>	<b>Chassis dimensions and mounting points</b> _____	<b>16</b>
<b>D.</b>	<b>Safety precautions</b> _____	<b>17</b>
<b>E.</b>	<b>Practical advice</b> _____	<b>19</b>
<b>F.</b>	<b>Installation instructions</b> _____	<b>22</b>
<b>G.</b>	<b>Conversion table</b> _____	<b>23</b>
<b>H.</b>	<b>Sealants</b> _____	<b>31</b>
<b>I.</b>	<b>Tightening torques</b> _____	<b>31</b>



1A01.2

## 6100 SERIES TRACTORS



# Introduction

## A . Using the manual

### General

The purpose of this manual is to assist Distributors and Dealers in the efficient installation, maintenance and repair of MASSEY FERGUSON machinery. Carrying out the procedures as detailed, together with the use of special tools where appropriate, will enable the operations to be completed within the time stated in the repair time schedule.

### Page numbering

Example : 7C01-3

This manual is divided into parts and sections. Each page contains the following information :

7 = Section

C = Part

01 = Sequence number within the Part

3 = Page number within the Part

The issue number and the date are indicated at the bottom of the page.

### Using the manual

To assist with locating information, each section of the manual is preceded by an index listing the Parts contained in that section.

The preliminary operations to be carried out in order to reach the item involved are listed at the beginning of each Part.

Items are indicated by means of identification marks (circles, squares, triangles).

### Meaning of identification marks

circle ○ (..) identifies part only

square □ [..] identifies part and indicates an adjustment

triangle △ /.. identifies part and indicates an important point to be noted during removal or refitment

### Amendments

Amended pages will be issued carrying the same page number as previous pages : only the issue number and the date will change.

Old pages should be destroyed.

### Special tools

Where the use of a special tool is necessary in an operation, the tool number is shown following the instruction requiring its use.

## Repairs and replacements

When parts have to be replaced, it is essential that only genuine MASSEY FERGUSON parts are used.

Attention is particularly drawn to the following points concerning repairs and the fitting of replacement parts and accessories.

Safety features embodied in the tractor may be impaired if other than genuine parts are fitted.

In certain territories, legislation prohibits the fitting of parts not to the tractor manufacturer's specification.

Torque wrench setting figures given in the Workshop Manual must be strictly adhered to. Locking devices must be fitted where specified. If the efficiency of a locking device is impaired during removal it must be renewed.

The tractor warranty may be invalidated by the fitting of other than genuine MASSEY FERGUSON parts. All MASSEY FERGUSON replacement parts have the full backing of the manufacturer's warranty. MASSEY FERGUSON Distributors and Dealers are obliged to supply only genuine service parts.

## Repair time schedule

The sections in the repair time schedule are identical to those in the workshop manual. The Repair Time Schedule is available, under publication number 3378043M1.



## Introduction

### B . Specifications

#### Engine

Characteristics	MF 6110	MF 6120	MF 6130	MF 6140	MF 6150	MF 6160	MF 6170	MF 6180	MF 6190
PERKINS Model	4.41	4.41	1004.4TLR	1004.4T2	1004-4THR2	1006-6 HR4	1006-6.HR3	1006-6TLR2	1006-THR2
Number of cylinders	4	4	4	4	4	6	6	6	6
Turbocharger	-	-	yes	yes	yes	-	-	yes	yes
Bore, (mm.)	101.1	101.1	100	100	100	100	100	100	100
Stroke, (mm.)	127	127	127	127	127	127	127	127	127
Cubic capacity (litre)	4100	4100	4000	4000	4000	6000	6000	6000	6000
Maxi. engine power DIN (KW)	51.5	58,9	62,6	66,2	69,9	73,5	81	88,3	95,6
P.T.O. power DIN (KW)	47	53	57	59,8	64	68	74	82,3	88,3
At engine speed of rev/min	2200	2200	2200	2200	2200	2200	2200	2200	2200
Maximum torque (Nm)	265	286	325	359	386	403	440	490	530
Engine speed at maximum torque	1400	1400	1400	1400	1200	1200	1200	1400	1400
Idling speed rev/min	750	750	750	850	850	850	850	850	1000
Maximum rated speed rev/min	2200	2200	2200	2200	2200	2200	2200	2200	2200
Maximum no load speed rev/min	2350	2350	2310	2310	2310	2310	2310	2310	2310
Permissible front P.T.O. power at 2200 rev/min (kW)	All the engine power						75		
Maximum torque							328		
Lubrication	Gear type pump - strainer on suction side and external canister type filter(s).								
Valves	Overhead, push-rod operated								
Valves clearance (Cold)									
- Inlet - mm (in)	0.30 (0.012)			0.20 (0.008)					
- Exhaust - mm (in)	0.30 (0.012)			0.45 (0.018)					
Engine oil cooler	no	no	yes	yes	yes	no	no	yes	yes

#### Fuel system and air cleaner

Supply pump	ACDELCO			
Fuel filter with sediment bowl	Yes			
Number of elements	1		2	
Injection pump	CAV	Lucas		Stanadyne
Injectors and nozzle holders	Lucas		CAV	Stanadyne
Cold weather starting	Thermostart			
Air Cleaner: Two-stage air filter with removable elements for servicing, with centrifugal prefilter and clogging indicator (warning lamp).				



1A01.4

---

## 6100 SERIES TRACTORS

---



### **Introduction**

#### **Electrical system**

Voltage:	12 volts negative earth.
Batteries:	2 maintenance free batteries.
Safety start:	operated by the clutch pedal.
Headlights:	European code 40/45 W
Sidelights:	5 W
Rear/brake lights:	21/5 W
Direction indicators:	21 W
Number plate light:	10 W
Work lamps:	55 W - iodine type H3
Instrument panel lighting and warning lights:	3 W - 2 W - 1.2 W
Roof light:	10 W

#### **Cooling**

Operation:	Centrifugal pump and pressurised radiator, regulated by thermostat Opening temperature : 82° C (179.2° F) controlled by thermostat.
Fan:	6110/6120/6130/6140/6150 : belt drive 6150: viscostatic 6160/6170/6180/6190 : viscostatic model gear driven water pump.
Belt deflection: (on the longest span)	19 mm (4 cyl. engine), 10 mm (6 cyl. engine).

#### **Transmission**

Clutch :	Spring-loaded multiple-disc clutch of oil bath type - 4 discs Pressure-loaded multiple-disc clutch of oil bath type - 5 discs
6110/6120/6130/6140/6150/6160 6170/6180/6190	- 16 or 32 speeds
Gearbox :	- 16 forward speeds
Without Dynashift :	- 16 reverse speeds - reverse shuttle (synchronised)
Creeper gear (option)	Ratio 4 to 1
Super creeper gear (option)	Ratio 7.8 to 1
Dynashift gearbox :	- 32 front speeds - 32 rear speeds - four selectable ratios without declutching - reverse shuttle (synchronised)



# 6100 SERIES TRACTORS





1A01.5



## Introduction

Road speeds at 2200 rev/min

6110/6120/6130/6140 - 16.9 - 34 tyres

Speed	Range	Speed-shift	16 SPEED 30 KPH				16 SPEED 40 KPH			
			FORWARD		REVERSE		FORWARD		REVERSE	
			KPH	MPH	KPH	MPH	KPH	MPH	KPH	MPH
1	LOW 	Slow	1.91	1.19	1.86	1.16	2.45	1.52	2.38	1.48
		Fast	2.45	1.52	2.38	1.48	3.10	1.92	3.01	1.87
2		Slow	2.93	1.82	2.85	1.77	3.70	2.30	3.59	2.23
		Fast	3.70	2.30	3.59	2.23	4.68	2.91	4.55	2.83
3		Slow	4.05	2.52	3.94	2.45	5.12	3.18	4.97	3.09
		Fast	5.12	3.18	4.97	3.09	6.48	4.03	6.30	3.91
4		Slow	5.87	3.65	5.70	3.54	7.42	4.61	7.21	4.48
		Fast	7.42	4.61	7.21	4.48	9.38	5.83	9.12	5.67
5	HIGH 	Slow	7.78	4.83	7.56	4.70	9.83	6.11	9.55	5.94
		Fast	9.83	6.11	9.55	5.94	12.43	7.72	12.08	7.51
6		Slow	11.75	7.30	11.42	7.10	14.86	9.28	14.48	8.97
		Fast	14.85	9.23	14.43	8.97	18.77	11.67	18.25	11.34
7		Slow	16.26	10.10	15.80	9.82	20.56	12.79	19.98	12.42
		Fast	20.56	12.79	19.98	12.42	25.98	16.15	25.26	15.70
8		Slow	23.55	14.64	22.89	14.23	29.76	18.50	28.92	17.97
		Fast	29.76	18.50	28.92	17.97	37.62	23.38	36.57	22.72

6150/6160/6170 -16.9 - 38 tyres

Speed	Range	Speed-shift	16 SPEED 30 KPH				16 SPEED 40 KPH			
			FORWARD		REVERSE		FORWARD		REVERSE	
			KPH	MPH	KPH	MPH	KPH	MPH	KPH	MPH
1	LOW 	Slow	1.92	1.19	1.86	1.16	2.43	1.51	2.36	1.46
		Fast	2.43	1.51	2.36	1.46	3.07	1.91	2.98	1.85
2		Slow	2.90	1.81	2.81	1.74	3.67	2.28	3.57	2.21
		Fast	3.67	2.28	3.57	2.21	4.64	2.88	4.51	2.80
3		Slow	4.01	2.50	3.90	2.42	5.08	3.16	4.94	3.07
		Fast	5.08	3.16	4.94	3.07	6.42	3.99	6.24	3.88
4		Slow	5.81	3.62	5.64	3.50	7.35	4.57	7.15	4.44
		Fast	7.35	4.57	7.15	4.44	9.29	5.78	9.03	5.61
5	HIGH 	Slow	7.71	4.80	7.49	4.66	9.74	6.06	9.47	5.90
		Fast	9.74	6.06	9.47	5.90	12.31	7.66	11.96	7.43
6		Slow	11.64	7.24	11.31	7.03	14.72	9.15	14.31	8.89
		Fast	14.72	9.15	14.31	8.89	18.60	11.56	18.08	11.23
7		Slow	16.11	10.02	15.66	9.73	20.37	12.66	19.80	12.30
		Fast	20.37	12.66	19.80	12.30	25.74	16.00	25.02	15.55
8		Slow	23.33	14.50	22.67	14.09	29.49	18.33	28.66	17.81
		Fast	29.49	18.33	28.66	17.81	37.27	23.17	36.22	22.51







1A01.6



## 6100 SERIES TRACTORS

**Introduction**

Road speeds at 2200 rev/min  
6180/6190 - 20.8 - 38 tyres

Speed	Range	Speed-shift	16 SPEED 30 KPH				16 SPEED 40 KPH			
			FORWARD		REVERSE		FORWARD		REVERSE	
			KPH	MPH	KPH	MPH	KPH	MPH	KPH	MPH
1	LOW	Slow	2.54	1.57	2.53	1.57	2.54	1.57	2.53	1.57
		Fast	3.22	2.00	3.20	1.99	3.22	2.00	3.20	1.99
Slow		3.84	2.38	3.82	2.37	3.84	2.38	3.82	2.37	
Fast		4.86	3.02	4.83	3.00	4.86	3.02	4.83	3.00	
2	W	Slow	5.32	3.30	5.29	3.28	5.32	3.30	5.29	3.28
		Fast	6.73	4.18	6.69	4.18	6.73	4.18	6.69	4.15
3		Slow	7.71	4.42	7.66	4.76	7.71	4.42	7.66	4.76
		Fast	9.74	6.05	9.69	6.02	9.74	6.05	9.69	6.02
Slow		10.22	6.35	10.16	6.31	10.22	6.35	10.16	6.31	
Fast		12.91	8.02	12.84	7.98	12.91	8.02	12.84	7.98	
4	H	Slow	15.43	9.59	15.34	9.53	15.43	9.59	15.34	9.53
		Fast	19.51	12.12	19.39	12.05	19.51	12.12	19.39	12.05
5	I	Slow	21.36	13.27	21.23	13.19	21.36	13.27	21.23	13.19
		Fast	27.00	16.78	26.84	16.68	27.00	16.78	26.84	16.68
Slow		30.92	19.21	30.74	19.10	30.92	19.21	30.74	19.10	
Fast		39.09	24.29	38.86	24.15	39.09	24.29	38.86	24.15	
6	G	Slow	21.36	13.27	21.23	13.19	21.36	13.27	21.23	13.19
		Fast	27.00	16.78	26.84	16.68	27.00	16.78	26.84	16.68
7	H	Slow	30.92	19.21	30.74	19.10	30.92	19.21	30.74	19.10
		Fast	39.09	24.29	38.86	24.15	39.09	24.29	38.86	24.15
Slow		30.92	19.21	30.74	19.10	30.92	19.21	30.74	19.10	
Fast		39.09	24.29	38.86	24.15	39.09	24.29	38.86	24.15	
8		Slow	30.92	19.21	30.74	19.10	30.92	19.21	30.74	19.10
		Fast	39.09	24.29	38.86	24.15	39.09	24.29	38.86	24.15

Road speeds "Dynashift" at 2200 rev/min -  
6110 to 6140 - 13.6R38 tyres

RATIO		FORWARD		REVERSE		
		KPH	MPH	KPH	MPH	
	1	A	2.04	1.27	2.06	1.28
		B	2.39	1.49	2.41	1.50
		C	2.82	1.75	3.10	1.93
		D	3.30	2.05	3.33	2.07
	2	A	3.47	2.16	3.50	2.18
		B	4.06	2.52	4.10	2.55
		C	4.79	2.98	4.83	3.00
		D	5.61	3.49	5.66	3.52
	3	A	4.57	2.84	4.61	2.87
		B	5.34	3.32	5.39	3.35
		C	6.31	3.92	6.37	3.96
		D	7.38	4.59	7.45	4.63
4	A	6.18	3.84	6.24	3.88	
	B	7.23	4.49	7.30	4.54	
	C	8.54	5.30	8.62	5.36	
	D	9.99	6.21	10.08	6.27	
	1	A	7.65	4.76	7.72	4.80
		B	8.96	5.57	9.05	5.63
		C	10.57	6.57	10.67	6.64
		D	12.38	7.69	12.50	7.78
	2	A	13.00	8.08	13.13	8.17
		B	15.22	9.46	15.36	9.55
		C	17.97	11.16	18.14	11.28
		D	21.03	13.07	21.23	13.21
	3	A	17.12	10.64	17.28	10.75
		B	20.03	12.45	20.22	12.58
		C	23.65	14.69	23.88	14.85
		D	27.68	17.20	27.94	17.38
	4	A	23.16	14.39	23.38	14.54
		B	27.11	16.84	27.37	17.02
		C	32.00	19.88	32.31	20.10
		D	37.45	23.27	37.81	23.52



# 6100 SERIES TRACTORS



1A01.7

## Introduction

### Road speeds "Dynashift" at 2200 rev/min - 6150 to 6170 - 16.9R38 tyres

RATIO	FORWARD		REVERSE		
	KPH	MPH	KPH	MPH	
<b>1</b>	A	2.04	1.27	2.06	1.28
	B	2.39	1.48	2.41	1.50
	C	2.82	1.75	3.10	1.93
	D	3.30	2.05	3.33	2.07
<b>2</b>	A	3.47	2.15	3.50	2.18
	B	4.06	2.52	4.10	2.55
	C	4.79	2.98	4.83	3.00
	D	5.60	3.48	5.65	3.51
<b>3</b>	A	4.56	2.83	4.60	2.86
	B	5.34	3.32	5.39	3.35
	C	6.30	3.92	6.36	3.96
	D	7.38	4.58	7.45	4.63
<b>4</b>	A	6.17	3.84	6.22	3.87
	B	7.22	4.49	7.29	4.53
	C	8.53	5.30	8.61	5.36
	D	9.98	6.20	10.07	6.26
<b>1</b>	A	7.65	4.75	7.72	4.80
	B	8.95	5.56	9.04	5.62
	C	10.56	6.56	10.66	6.63
	D	12.36	7.68	12.48	7.76
<b>2</b>	A	12.99	8.07	13.12	8.16
	B	15.20	9.45	15.34	9.54
	C	17.95	11.15	18.12	11.27
	D	21.00	13.05	21.20	13.19
<b>3</b>	A	17.10	10.62	17.26	10.74
	B	20.01	12.43	20.20	12.56
	C	23.62	14.68	23.84	14.83
	D	27.65	17.18	27.92	17.37
<b>4</b>	A	23.14	14.38	23.36	14.53
	B	27.08	16.83	27.34	17.01
	C	31.96	19.86	32.26	20.07
	D	37.41	23.25	37.77	23.49

### Road speeds "Dynashift" at 2200 rev/min - 6180/6190 - 18.4R38 tyres

RATIO	FORWARD		REVERSE		
	KPH	MPH	KPH	MPH	
<b>1</b>	A	2.09	1.30	1.97	1.23
	B	2.45	1.52	2.31	1.44
	C	2.89	1.80	2.72	1.69
	D	3.38	2.10	3.19	1.98
<b>2</b>	A	3.55	2.21	3.35	2.08
	B	4.16	2.58	3.92	2.44
	C	4.91	3.05	4.63	2.88
	D	5.75	3.57	5.42	3.37
<b>3</b>	A	4.68	2.91	4.41	2.74
	B	5.47	3.40	5.16	3.21
	C	6.46	4.01	6.85	4.26
	D	7.56	4.70	7.13	4.43
<b>4</b>	A	6.33	3.93	5.97	3.71
	B	7.41	4.60	6.99	4.35
	C	8.74	5.43	8.24	5.13
	D	10.23	6.36	9.65	6.00
<b>1</b>	A	7.84	4.87	7.39	4.60
	B	9.17	5.70	8.65	5.38
	C	10.83	6.73	10.21	6.35
	D	12.67	7.88	11.95	7.43
<b>2</b>	A	13.32	8.28	12.56	7.81
	B	15.59	9.69	14.70	9.14
	C	18.50	11.43	17.35	10.79
	D	21.54	13.38	20.31	12.63
<b>3</b>	A	17.53	10.89	16.53	10.28
	B	20.52	12.75	19.35	12.04
	C	24.22	15.05	22.84	14.21
	D	28.35	17.61	26.73	16.63
<b>4</b>	A	23.72	14.74	22.37	13.91
	B	27.76	17.25	26.18	16.28
	C	32.77	20.36	30.90	19.22
	D	38.36	23.83	36.17	22.50



1A01.8

## 6100 SERIES TRACTORS



### Introduction

#### Final reduction units

Reduction units :	epicyclic, in the rear axle housings.	
Reduction ratios :	6110/6120/6130/6140 (normal duty)	4.714 to 1
	6150/6160/6170 (heavy duty)	5.077 to 1
	6180/6190	5.571 to 1

#### Power take-off

Independent power take-off (IPTO)  
P.T.O. ratio

Proportional to the engine speed. Hydraulic clutch.  
540 rev/min at 1980 engine rev/min  
1000 rev/min at 2000 engine rev/min

Speed changing  
(according to model)

Either by changing shafts :  
- 540 rev/min shaft, 35 mm (1<sup>3</sup>/<sub>8</sub> in) diameter, 6 splines.  
- 1000 rev/min shaft, 35 mm (1<sup>3</sup>/<sub>8</sub> in) diameter, 21 splines  
Or by external selection lever on rear L.h.s.  
- shaft 35 mm - 6 splines

"Economy" independant power  
take-off (optional extra)

The normal 540 and 1000 rev/min p.t.o. speeds can be  
obtained at the above stated engine speeds or at 1550  
engine rev/min by selecting the "economy" ratio.  
Lever in the cab.

Control

Ground speed P.T.O.  
(optional extra)

An addition to the independent P.T.O.

Control

Lever in the cab.

Speed : MF 6110/6120/6130/6140

- 540 rev/min - 7.87 revolutions of the p.t.o. shaft for 1 turn of  
the wheel axle.  
- 1000 rev/min - 14.83 revolutions of the p.t.o. shaft for 1 turn  
of the wheel axle.

Speed : MF 6150/6160/6170

- 540 rev/mn - 8.48 revolutions of the p.t.o. shaft for 1 turn of  
the wheel axle.  
- 1000 rev/mn - 15.54 revolutions of the p.t.o. shaft for 1 turn  
of the wheel axle.

Speed : MF 6180/6190

- 540 rev/mn - 8.23 revolutions of the p.t.o. shaft for 1  
revolution of the wheel.  
- 1000 rev/mn - 15.08 revolutions of the p.t.o. shaft for 1  
revolution of the wheel.

Front power take-off (optional extra)

Control

Hydraulic clutch mechanism controlled by a button in  
the cab.

Ratio

1000 rev/min at 2040 engine rev/min. - 2.04. : 1

#### Four-wheel drive front axle

Clutch mechanism  
Differential Lock

Hydraulic, electrically actuated by push button in the cab  
Front and rear differential lock-hydraulic with electrical control.



## 6100 SERIES TRACTORS



1A01.9

# Introduction

## Hydraulics

Two stage gear pump, driven directly by the engine, supplies :

### 1st Stage

This circuit supplies 29 l/min (6.4 Imp. gal/min) (7.6 US gal/min) at maximum engine speed.

Maximum pressure : 17 bar

### 1. Hydrostatic steering

Hare/Tortoise range gear

Differential lock (rear and front)

I.P.T.O. clutch

P.T.O. brake

Front P.T.O. (if fitted)

Four-wheel drive (if fitted)

Top up of brake master cylinder and clutch master cylinder

Clutch control valve (pressure loaded)

Lubrication of gearbox, P.T.O. and rear axle

Gearbox front unit (Speedshift or Dynashift)

Electro-hydraulic reverse shuttle (if fitted)

### 2nd Stage

This circuit supplies 50 l/min (11 Imp. gal/min) (13.2 US gal/min)

Maximum pressure : 185 bar

### 2. Trailer brake supply

Auxiliary hydraulic system

Hydraulic lift.

### Filtration

External 150-micron throwaway, canister type suction strainer.  
External 15 micron High pressure filter.

## Hydraulic lift

Type : 3-point, Category 2 or 3, with fixed, telescopic or quick attach hook type ball ends (according to model).

Rams : 2. Lifting force (see charts)

### MF 6110/6120/6130/6140 - Rams Ø 57 mm (2.24 in)

Position of lift rod on lower links mm (in)	Length of lift rods mm (in)	Lower links horizontal Kg (Lb)	Lower links fully raised Kg (Lb)
508 (20)	565 (22.2) 765 (30.1)	2885 (6360) 3010 (6636)	3825 (8433) 3165 (6977)
608 (24)	565 (22.2) 765 (30.1)	- 3430 (7562)	4190 (9237) 3485 (7683)

### MF 6150/6160/6170 - Rams Ø 66 mm (2.59 in)

Position of lift rod on lower links mm (in)	Length of lift rods mm (in)	Lower links horizontal Kg (Lb)	Lower links fully raised Kg (Lb)
550 (21.6)	595 (23.4) 827 (32.5)	4350 (9590) 4276 (9427)	5194 (11451) 4308 (9497)
650 (25.6)	595 (23.4) 827 (32.5)	5740 (12654) 4788 (10556)	5689 (12541) 4703 (10368)

### MF 6150/6160 - Rams Ø 57 mm (2.24 in)

Position of lift rod on lower links mm (in)	Length of lift rods mm (in)	Lower links horizontal Kg (Lb)	Lower links fully raised Kg (Lb)
550 (21.6)	595 (23.4) 827 (32.5)	3192 (7037) 3138 (6918)	3812 (8404) 3162 (6971)
650 (25.6)	595 (23.4) 827 (32.5)	4213 (9286) 3514 (7747)	4175 (9204) 3452 (7610)

### MF 6180/6190 - Rams Ø 73 mm (2.87 in)

Position of lift rod on lower links mm (in)	Length of lift rods mm (in)	Lower links horizontal Kg (Lb)	Lower links fully raised Kg (Lb)
550 (21.6)	595 (23.4) 827 (32.5)	5425 (11960) 5000 (11023)	6510 (14352) 5087 (11215)
650 (25.6)	595 (23.4) 827 (32.5)	8090 (17835) 5717 (12604)	7117 (15690) 5595 (12335)



1A01.10

## 6100 SERIES TRACTORS



### Introduction

#### Brakes

Type : Oil immersed single disc per wheel, 343 mm (13.50 in), outside diameter. Inside diameter of lining :  
 6110/6120/6130/6140 : 296 mm (11.65 in)  
 6150/6160/6170/6180/6190 : 274,5 mm (10.81 in)

Operation : Hydraulic, from two master cylinders, automatic adjustment.  
 Handbrake : Operates on the rear axle bevel gear.  
 Trailer brake : According to model by an hydraulic valve.

#### Differential lock - Rear axle

Type : Positive clutch  
 Control : Hydraulic, with electrical control.

#### Steering

Type : Hydrostatic fixed or tiltable telescopic steering column. One double action central ram

Theoretical turning circle	6110/20/30/40	6150	6160	6170/80/90
Tyres *	13.6-24	13.6-28	13.6-28	14.9-28
- 2 WD	•	•	•	•
- 4 WD	•	•	•	•
Track adjustments (m)	-	1,75	1,85	2,05
Angle	57°	55°	55°	55°
Radius tyres (outer)				
- without braking (m)	-	4,37	4,60	4,94

\* with front axle disengaged

#### Wheels

FRONT 2-wheel drive pressed steel  
 4-wheel drive pressed steel  
 REAR pressed steel with manual adjustment or cast with power adjust variable track (P.A.V.T.), or manual adjustment.



## 6100 SERIES TRACTORS



1A01.11

### Introduction

#### Tyres

Compatibility of front/rear tyres of 4-wheel drive tractors same make and model.

Tyres	Front	Rear	Front	Rear	Front	Rear
	11.2R28	13.6R38	13.6R28	16.9R38	420-70R24	520-70R34
		16.9R34		18.4R34	440-65R28	540-65R38
		18.4R30	14.9R24	13.6R38	420-70R28	520-70R38
(1) 12.4R24		13.6R38		18.4R34	480-65R28	520-70R38
		16.9R30	14.9R28	18.4R38		600-65R38
		18.4R30	(1) 380-70R24	480-70R34		
	13.6R24	13.6R38	380-70R28	480-70R38		
		16.9R34				

**NOTE :** The data in this table is not binding. Ask your dealer for further information on other possible choices.

(1) 6110/6120/6130/6140/6150 only

#### Water Ballasting (75° fill)

Front tyres	Rim	Litre	Imp. gal.	US gal.	Kg	lb
11.2R28	W9 x 28	98	21.56	25.9	98	216
13.6R24	W12 x 24	139	30.60	36.7	139	306
13.6R28	W11 or W12 x 28	150	33.00	39.6	150	330
14.9R24	W12 x 24	178	39.20	47.0	178	392
14.9R28	W12 x 28	200	44.00	52.8	200	440
380-70R24	W12 x 24	161	35.40	42.5	161	354
380-70R28	W12 x 28	174	38.30	45.9	174	383
440-65R28		202	44.44	52.52	202	444
420-70R24	W12 x 24	192	42.20	50.7	192	423
420-70R28	W12 x 28	214	47.10	56.5	214	471
480-65R28	W12 x 28	255	56.10	67.3	255	561

Rear tyres	Rim	Litre	Imp. gal.	US gal.	Kg	lb
13.6R38	W11 or W12 x 38	184	40.50	48.6	184	405
16.9R30	W14 x 30	260	57.20	68.7	260	472
16.9R34	W14 or W15 x 34	285	62.70	75.3	285	627
16.9R38	W14 or W15 or W16 x 38	304	66.80	80.3	304	669
18.4R30	W14 or W15 or W16 x 30	304	66.80	80.3	304	669
18.4R34	W15 or W16 x 34	345	75.90	91.1	345	760
18.4R38	W15 or W16 x 38	386	84.90	102.0	386	850
480-70R34	W15 x 34	349	76.70	92.2	349	768
480-70R38	W15 x 38	375	82.50	99.0	375	826
520-70R34	W15 x 34	424	93.29	112.0	424	934
520-70R38	W15 x 38	452	99.45	119.4	452	995
540-65R38	W14, 15 or 16 x 38	386	84.92	100.36	386	849
600-65R38	W15 or W16 x 38	521	115.00	135.46	521	1146



1A01.12

## 6100 SERIES TRACTORS



### Introduction

#### Capacities

Fuel tank : .....	6110/6120/6130/6140 :	130 l (28.60 Imp. gal.) (34.34 US gal.)
.....	6150/6160/6170/6180/6190 :	160 l (35.20 Imp. gal.) (42.27 US gal.)
Cooling system : .....	6110/6120/6130/6140/6150 :	17 l (3.74 Imp. gal.) (4.49 US gal.)
.....	6160/6170/6180/6190 :	25 l (5.50 Imp. gal.) (6.60 US gal.)
Engine sump : .....	6110/6120/6130/6140/6150 :	7,4 l (1.63 Imp. gal.) (1.95 US gal.)
.....	6160/6170/6180/6190 :	14,8 l (3.26 Imp. gal.) (3.91 US gal.)
Transmission/rear axle :* .....	6110/6120/6130/6140/6150/6160 :	62 l (13.66 Imp. gal.) (16.4 US gal.)
.....	6170/6180/6190 :	68 l (15 Imp. gal.) (18 US gal.)
Front axle assembly : .....	6110/6120/6130/6140/6160/6170/6180 :	6 l (1.32 Imp. gal.) (1.58 US gal.)
.....	6150 :	9 l (1.98 Imp. gal.) (2.38 US gal.)
.....	6190 :	6,7 l (1.47 Imp. gal.) (1.77 US gal.)
Front final reduction units (each) : .....	6110/6120/6130/6140 :	1 l (0.22 Imp. gal.) (0.26 US gal.)
.....	6150/6160 :	1,2 l (0.26 Imp. gal.) (0.32 US gal.)
.....	6170/6180/6190 :	2 l (0.44 Imp. gal.) (0.53 US gal.)

\* When working on steep slopes 10 l (2.2 Imp. gal.) (2.7 US gal.) of oil can be added.

#### Front and rear static axle load limits - Kg (lb) at 1,5 bar (21.77 PSI) pressure

Type	Front		Rear	
	Kg (lb)	mm (in)	Kg (lb)	mm (in)
<b>2 WD</b> Normal duty				
6110/6120/6130/6140/6150	3800 (8377)	track 1.383 (54.45)	6340 (13977)	track 1.772 (69.76)
Heavy duty				
6150/6160/6170	4350 (9590)	track 1,484 (58.42)	6340 (13977)	track 1,772 (69.76)
6180/6190	4350 (9590)	track 1,484 (58.42)	7600 (16755)	track 1,835 (72.25)
<b>4 WD</b>				
6110/6120/6130/6140/6150	4000 (8818)	track 1,650 (64.96)	6340 (13977)	track 1,772 (69.76)
6160/6170	5000 (11023)	track 1,800 (70.87)	6340 (13977)	track 1,772 (69.76)
6180	5000 (11023)	track 1,800 (70.87)	7600 (16755)	track 1,835 (72.25)
6190	6000 (13228)	track 1,920 (75.60)	7600 (16755)	track 1,835 (72.25)



# 6100 SERIES TRACTORS



1A01.13

## Introduction

### Dimensions and weights

CHARACTERISTICS mm (in) - Kg (lb)	6110		6120/6130/6140		6150		6160/6170		6180		6190	
	2WD	4WD	2WD	4WD	2WD	4WD	2WD	4WD	2WD	4WD	2WD	4WD
A Wheelbase	2371 (93.34)	2375 (93.35)	2371 (93.34)	2375 (93.35)	2549 (100.35)	2553 (100.51)	2696 (106.10)	2699 (106.25)	2696 (106.10)	2699 (106.25)	2696 (106.10)	2699 (106.25)
B Overall length with drawbar	3995 (117.9)	4069 (160.2)	3995 (117.9)	4069 (160.2)	4137 (162.87)	4137 (162.87)	4320 (170)	4472 (176)	4402 (173.3)	4402 (173.3)	4527 (178.2)	4527 (178.2)
C Height to roof (cab tractor)	2627 (103.4)	2627 (103.4)	2627 (103.4)	2627 (103.4)	2724 (107.2)	2724 (107.2)	2755 (108.5)	2755 (108.5)	2768 (109)	2768 (109)	2908 (114.5)	2908 (114.5)
D Overall width (1)	2570 (101.2)	2570 (101.2)	2570 (101.2)	2570 (101.2)	2570 (101.2)	2570 (101.2)	2570 (101.2)	2570 (101.2)	2733 (107.6)	2733 (107.6)	2832 (111.5)	2832 (111.5)
E Ground clearance (under drawbar Frame)	385 (15.2)	385 (15.2)	385 (15.2)	385 (15.2)	385 (15.2)	385 (15.2)	445 (17.5)	445 (17.5)	442 (17.4)	442 (17.4)	502 (19.8)	502 (19.8)
F Height to steering wheel	1971 (77.6)	1971 (77.6)	1971 (77.6)	1971 (77.6)	2023 (79.6)	2023 (79.6)	2068 (81.4)	2068 (81.4)	2110 (83)	2110 (83)	2250 (88.6)	2250 (88.6)
Total weight (with full tank, without extra weight steel wheels)	3565 (7859)	3840 (8465)	3565 (7859)	3840 (8465)	4120 (9080)	4400 (9698)	4440 (9800)	4675 (10320)	4190 (9249)	4590 (10132)	4805 (10607)	5040 (11126)
Rear tyres dimensions	16.9-34		16.9-34		16.9-34		18.4-38		16.9-38		20.8-38	

G Distance between flanges	Rear axle		Front axle		
			AG85	AG105	AG125
* Normal duty axle housing shaft Ø 82	1774 (69.84)		1669 (67)	1800 (70.86)	1800 (70.86)
* Shaft straight shaft Ø 82	1835 (72.34)				
	2230 (87.79)				
H Stud distance	Ø 82 shafts (3.23) 203,20 (8.00)		275 (10.8)		335 (13.20)
L Centring diameter	149,35 (5.88)				280,8 (11.04)
I Stud length					
Wheel with steel hub	41 (1.61)		43 (1.70)	43 (1.70)	55 (2.16)
Wheel with cast iron hub	66 (2.60)				
J Stud diameter	M 18 x 1,5		M 18 x 1,5		M 22 x 1,5
K Number of studs	8		8		10

(1) These dimensions are applicable for tractors adjusted for max. track

\* 6180/6190 only

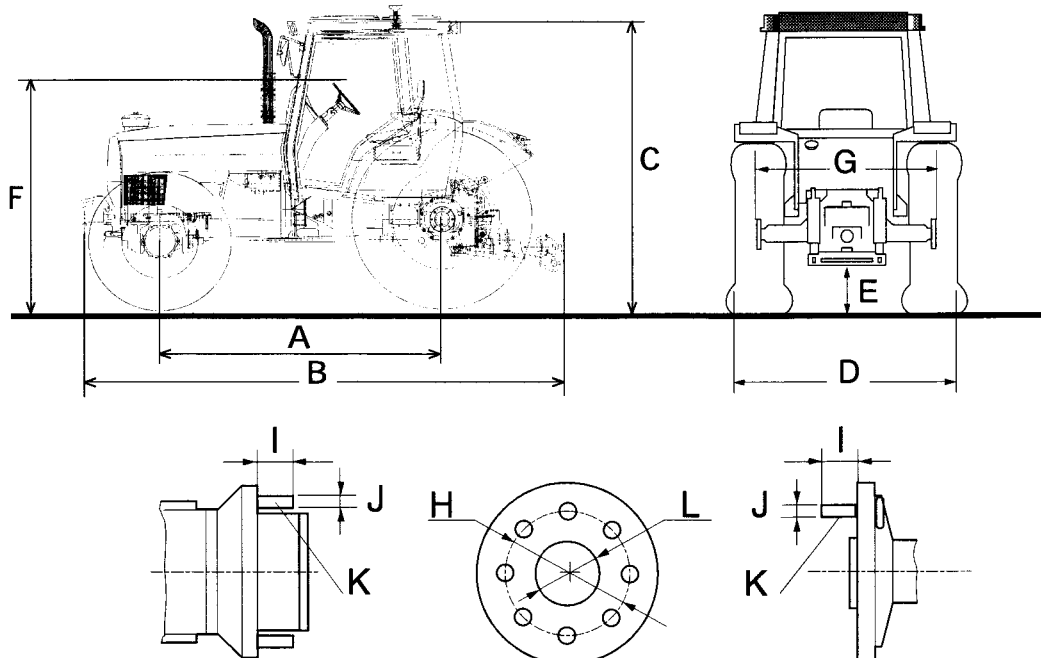





1A01.14

## 6100 SERIES TRACTORS

**Introduction****C . Chassis dimensions and mounting points**

Ref.	6110/6130 6140	6150	6160/6170	6180/6190	Ref.	6110/6130 6140	6150	6160/6170	6180/ 6190
1	301,50	301,50	301,50	301,50	37	155	155	155	155
2	20,00	20,00	20,00	20,00	38	125	125	125	125
3	101,60	101,60	61,60	61,60	39	125	125	125	125
4	44,45	44,45	-	-	40	52	52	52	52
5	60,32	60,32	-	-					
6	101,60	101,60	-	-	41	52	52	52	52
7	481,00	570,00	621,40	621,40	42	79,5±2	79,5±2	79,5±2	96,5±2
8	112,40	201,40	49,60	49,60	43	46	46	46	46
9	25,25	25,25	6,27	6,27	44	190	190	190	190
10	70,00	70,00	101,60	101,60	45	100	100	100	100
					46	226	226	226	226
11	-	-	44,45	44,45	47	92	92	92	123
12	-	-	60,27	60,27	48	Ø149,35	Ø149,35	Ø149,35	Ø149,35
13	-	-	101,60	101,60	49	371,12	371,12	371,12	371,12
14	698,00	787,00	736,80	736,80					
15	340,05	429,05	370,60	370,60	50	320	320	320	320
16	571,75	571,75	771,50	771,50	51	110	110	110	110
17	896	896	896	896	52	130	130	130	130
18	890	890	890	890	53	65	65	65	65
19	567	567	567	567	54	142,75	142,75	142,75	142,75
20	-	-	94	94	55	20	20	20	20
					56	817	817	817	817
21	267	267	267	267	57	310	310	310	310
22	127,07	127,07	127,07	127,07	58	142,75	142,75	142,75	142,75
23	53	53	53	53	59	223	223	223	223
24	101,60	101,60	101,60	101,60	60	315	315	315	324
25	31,40	31,40	31,40	31,40					
26	101,60	101,60	101,60	101,60	61	100	100	100	
27	100	100	100	161	62	65	65	65	
28	260	260	260	280	63	65	65	65	
29	43	43	43	43	64	40 or 66	40 or 66	40 or 66	40 or 66
30	106	106	106	106	65	-	-	-	323,90
					66	-	-	-	76,20
31	224	224	224	224	67	-	-	-	120,60
32	128	128	128	128	68	-	-	-	241,30
33	1774	1774	1774	1835	69	3056	3231	3388	3388
34	-	-	-	2228					
35	-	-	-	2870	70	Ø203,2±0,3	Ø203,2±0,3	Ø203,2±0,3	Ø203,2±0,3
36	155	155	155	155	71		89		

A : 6 holes M20 through  
 B : 8 holes M20 x 38 deep  
 C : 12 holes M20 x 38 deep  
 D : 2 holes M20 through  
 E : 6 holes M16 x 31 deep  
 E' : 2 holes M16 x 25 deep  
 F : 2 holes diam. 37 - 37.16

G : 8 holes M18 x 31 deep  
 H : 8 studs M18 - 1.5  
 I : 4 holes M16 x 25 deep  
 J : 5 holes M20 x 35 deep  
 K : 4 holes M16 x 30 deep  
 L : 4 holes diam. 20.70 ± 0.12  
 through

v : 4 WD centerline  
 w : Crankshaft centerline  
 x : Differential centerline  
 y : Trumpet centerline  
 z : PTO centerline



# Introduction

## 6 CYL.

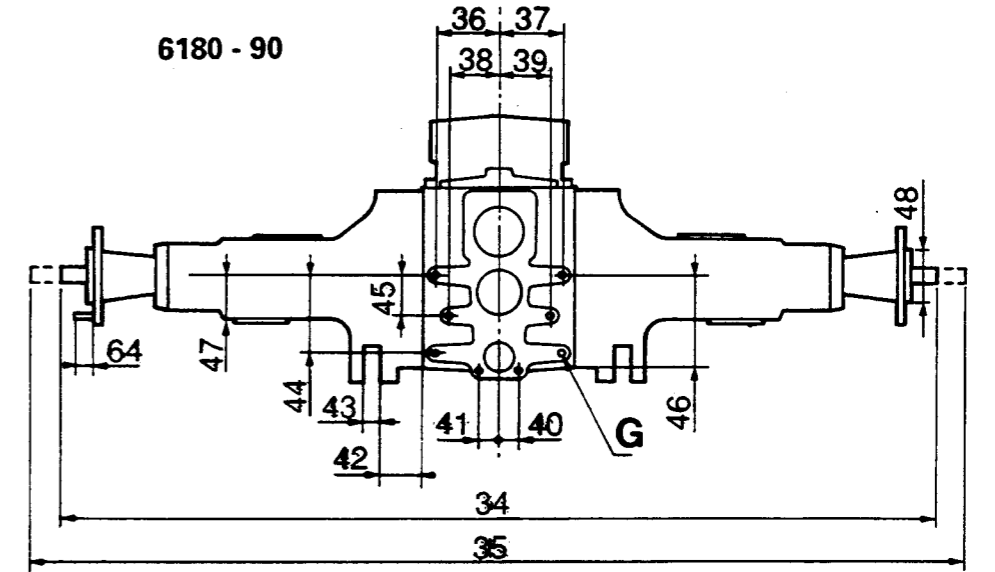
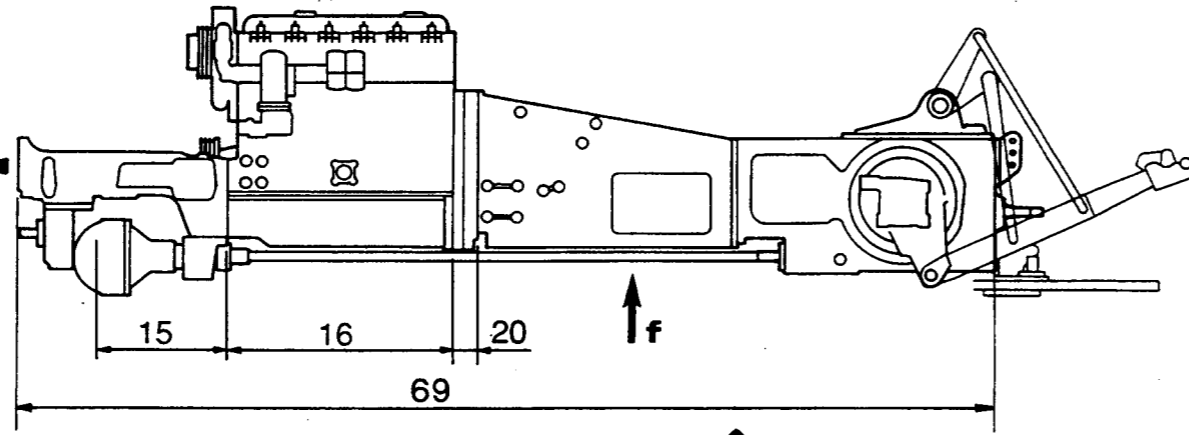
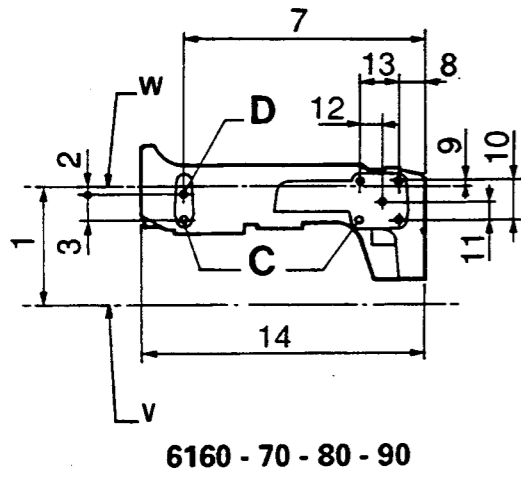

## 4 CYL.

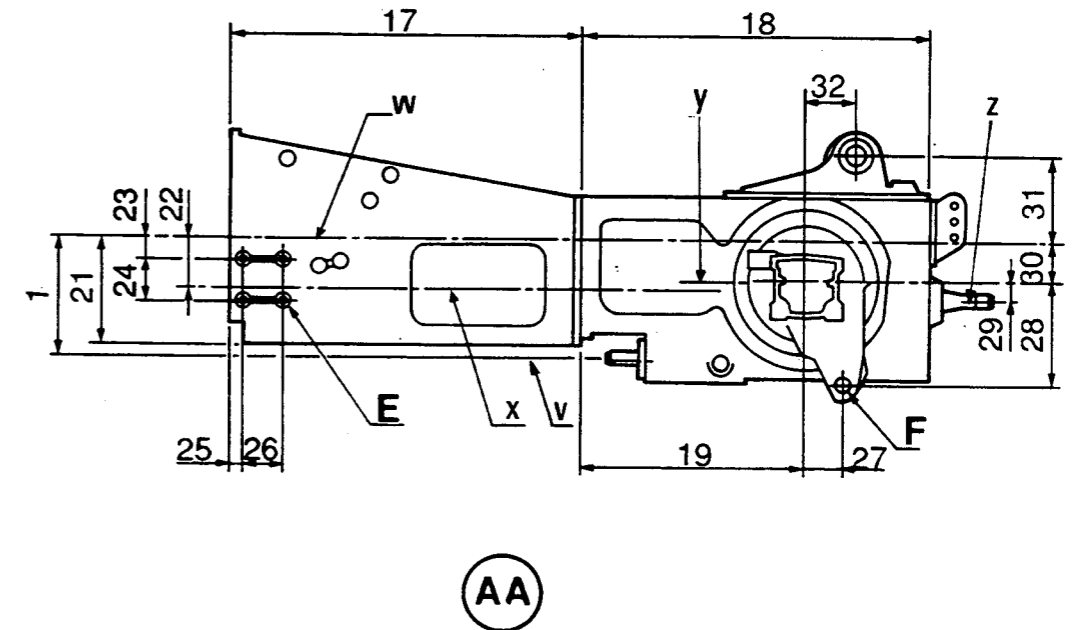
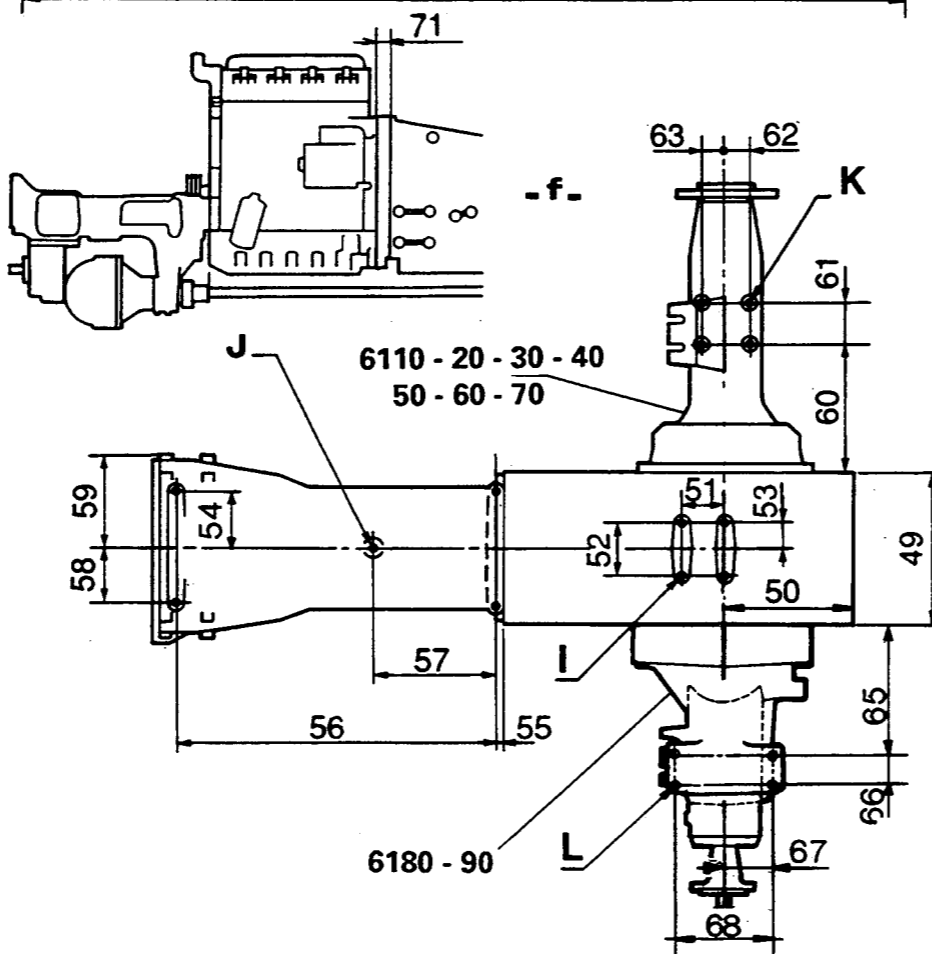
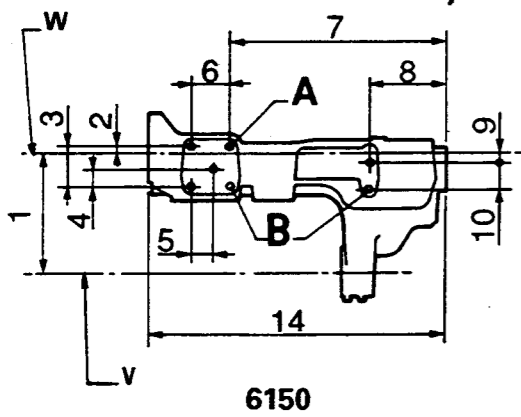
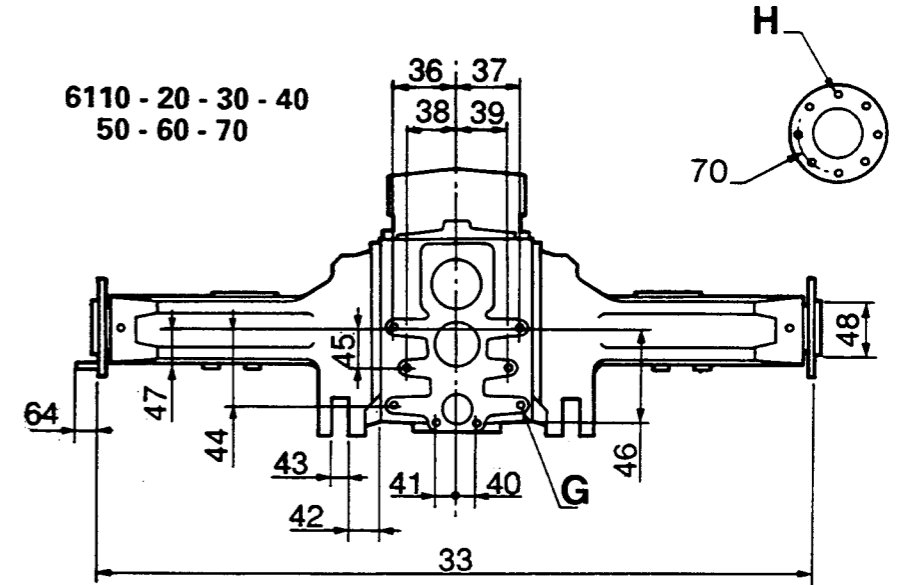
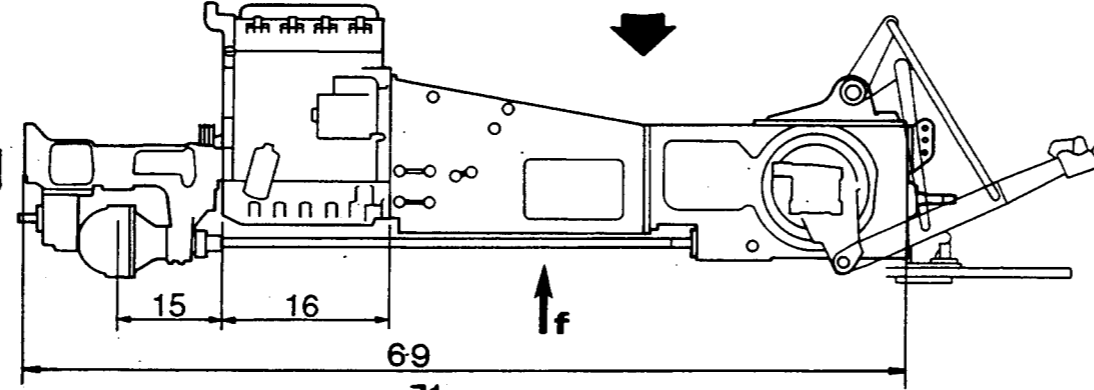
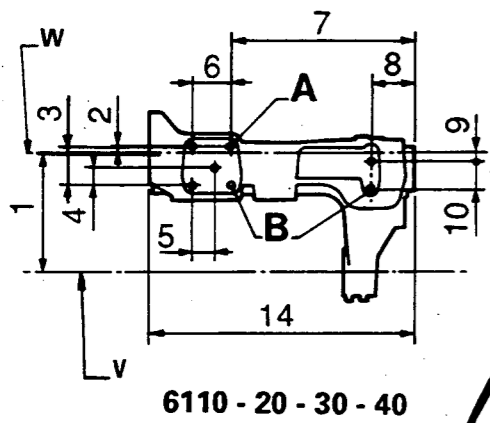



# Introduction

## D. Safety precautions

When replacing a tractor part bearing a safety decal (yellow) a new safety sticker MUST be affixed onto the replacement part. A full list of the locations for all safety decals are specified below.

**G.B. CAUTION**



Before operating, read operator's instruction book thoroughly.  
Do not start engine until everyone is a safe distance from tractor and equipment.  
Keep all shields, covers and guards in place while engine is running.  
Keep hands, feet and clothing away from power driven or moving parts.

Always drive with due care and attention.

If differential lock does not disengage automatically, depress clutch pedal.  
Brake pedals must always be coupled together when independent brakes are not being used.

When attaching equipment check operator's instruction book for front and rear axle load limits.  
Put the gears lever (1-2-3-4) in neutral position and put the reverse/forward lever in forward position or reverse position in order to use the external lift controls.  
Ensure that all wheel and rim nuts are tightened as specified in operator's instruction book.  
On public roads, use SMV emblem and flashing warning lights where required by law.

Before leaving tractor, apply parking brake, lower equipment, stop engine and remove key from starter switch.

DO NOT REMOVE OR OBSCURE DECAL 3580321 M3

**WARNING**



Gears lever (1-2-3-4) must be in his neutral position and the reverse/forward lever in forward position or reverse position:  
- In order to use the external lift controls.  
- When the driver is not in his seat.

DO NOT REMOVE OR OBSCURE DECAL 3713705 M1

**WARNING**



When the tractor is stationary, it is imperative to fully apply the handbrake because leaving the tractor in gear will not prevent movement.  
When attempting to start the engine using a slave battery, ensure that the gear lever (1, 2, 3, 4) is in neutral.  
Never connect a slave battery directly to the starter motor



**G.B. WARNING**



High pressure steam and hot water.  
Remove filler cap with extreme care.

DO NOT REMOVE OR OBSCURE DECAL 3595685 M1

**G.B. CAUTION**

DO NOT REMOVE OR OBSCURE DECAL

**G.B. WARNING**



Before working on the tractor, disconnect negative leads to all batteries.

**WARNING**



Before removing any battery, disconnect all negative leads before positive leads.

DO NOT REMOVE OR OBSCURE DECAL 3595679 M1

**G.B. CAUTION**



Keep all shields, covers and guards fastened in place while engine is running.

**WARNING**



Beware hot parts

DO NOT REMOVE OR OBSCURE DECAL 3595678 M1

**G.B. CAUTION**



TO AVOID POSSIBLE TRACTOR OVERTURN, PULL ONLY FROM DRAWBAR OR LOWER LINKS OF THREE POINT HITCH

2752579 M1

**G.B. WARNING**



Always disengage PTO and stop engine before attaching or detaching PTO shafts or working on PTO driven equipment.

Always fit PTO cover when PTO is not in use.

**CAUTION**



Do not stand between tractor and equipment when operating controls.

Tow only with MF approved tractor drawbar or hitch

DO NOT REMOVE OR OBSCURE DECAL 3581563 M1

**CAUTION**



Belt for use only on tractors with safety structures.

DO NOT REMOVE OR OBSCURE DECAL 523784 M3

**G.B. WARNING**



Before working on the tractor or removing this cover, disconnect negative leads to all batteries.

**CAUTION**



Use seat belt at all times.  
Keep belt adjusted snugly.

DO NOT REMOVE OR OBSCURE DECAL 3580316 M1

**CAUTION**



Voir Manuel d'Utilisation. See Operator Instruction Book. Vedere Libretto d'Uso. Siehe Betriebsanleitung Ver Manual del Operator

3617574 M1

**CAUTION**



Do not short across starter terminals to start engine.  
Never start engine while standing on the ground.  
Start engine only with start key from operator's seat, ensuring that gearbox and PTO are in neutral with parking brake applied.

DO NOT REMOVE OR OBSCURE DECAL 3596432 M1

**G.B. WARNING**



If tractor is overturning, hold onto steering wheel.  
Do not leave seat



DO NOT REMOVE OR OBSCURE DECAL 3580315 M1

**CAUTION**



IT IS IMPERATIVE TO USE THE TRANSMISSION OIL RECOMMENDED IN THE OPERATING MANUAL

3713699M1



1A01.18

# 6100 SERIES TRACTORS



## Introduction

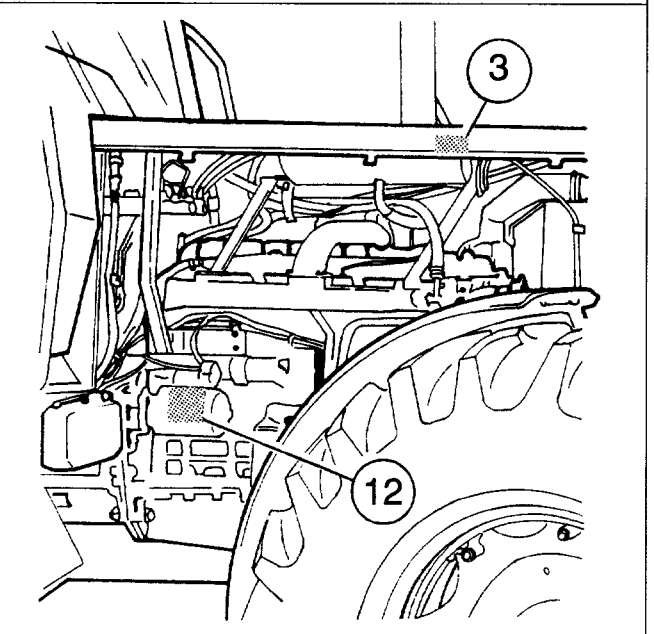
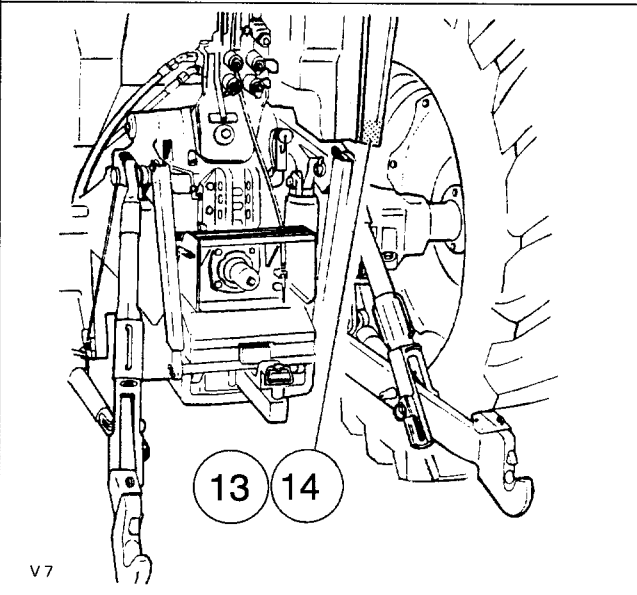
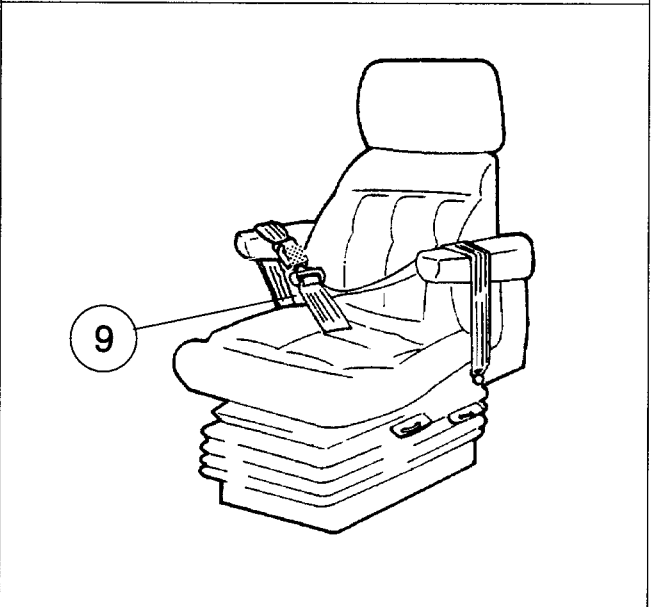
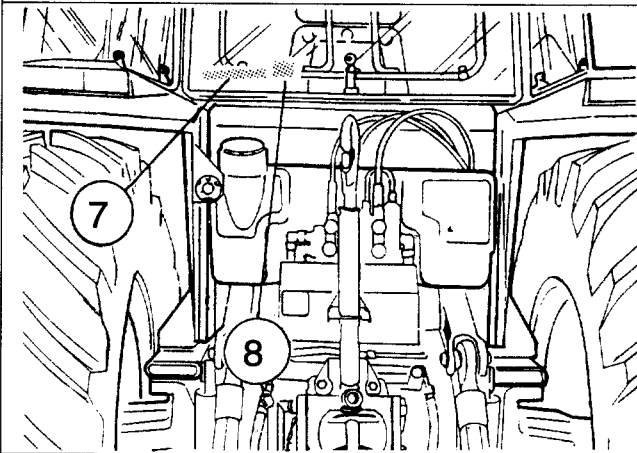
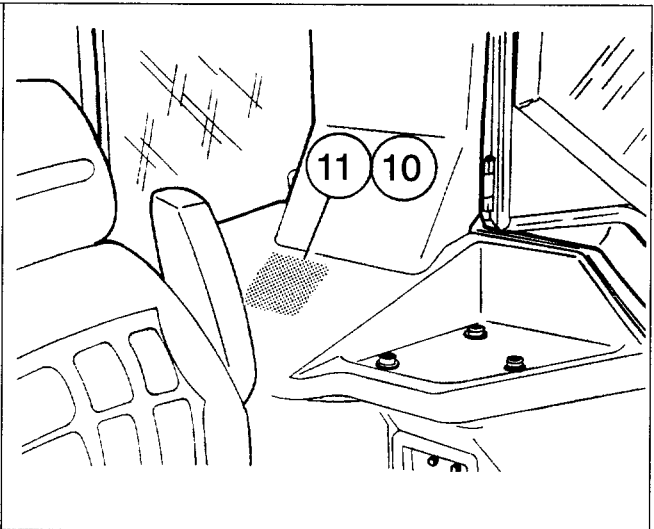
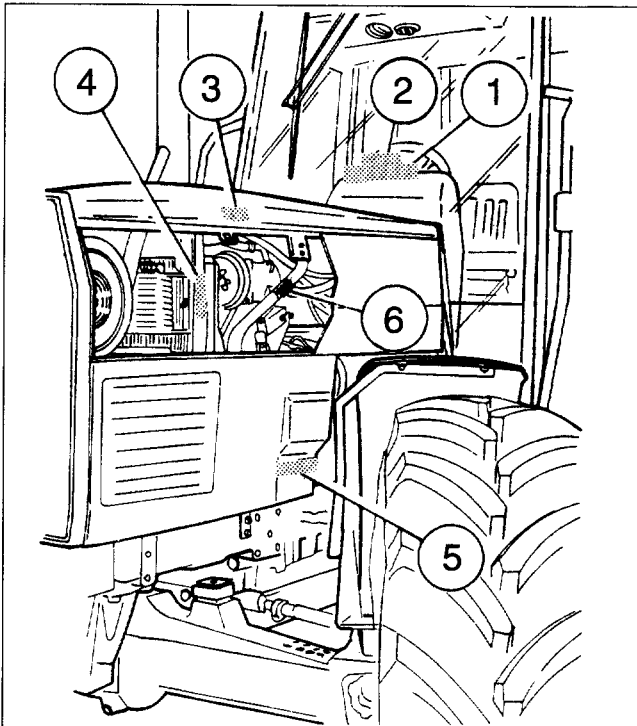

v7



## Introduction

### E . Practical advice

#### Safety

Your safety and that of others must always be the first consideration when working around machines of any type.

Safety is a matter of thoroughly understanding the job to be done, the correct use of tools and equipment, and the application of good common sense.

#### Trouble-shooting

The following procedure, combined with the information contained in the workshop manual will be helpful in tracing faults accurately.

It consists of following a number of logical steps to locate and correct the problem.

1. Determine the problem.
2. List possible causes.
3. Differentiate the causes.
4. Conduct checks in logical order to determine the exact cause.
5. Consider approximate remaining service life against cost of parts and labour.
6. Make any necessary repair.
7. Recheck the parts and functions for correct operation.

#### Handling of heavy components

Unless otherwise specified, all removals should be accomplished using adjustable lifting equipment. All supporting slings must be parallel to each other and as near vertical as possible in relation to the object being lifted. However, where slings are of a far greater capacity than the weight of the load to be lifted, a triangular lifting arrangement may be used (2, 3 or 4 strands from a single ring beneath the hoist hook). When removing a component at an angle, remember that the capacity of an eyebolt is reduced when the angle between the supporting members and the object becomes less than 90° (correct and incorrect method of lifting).

Eyebolts and brackets must never be bent and must only work under tension. A length of pipe and a washer may be used to reduce tension on eyebolts.

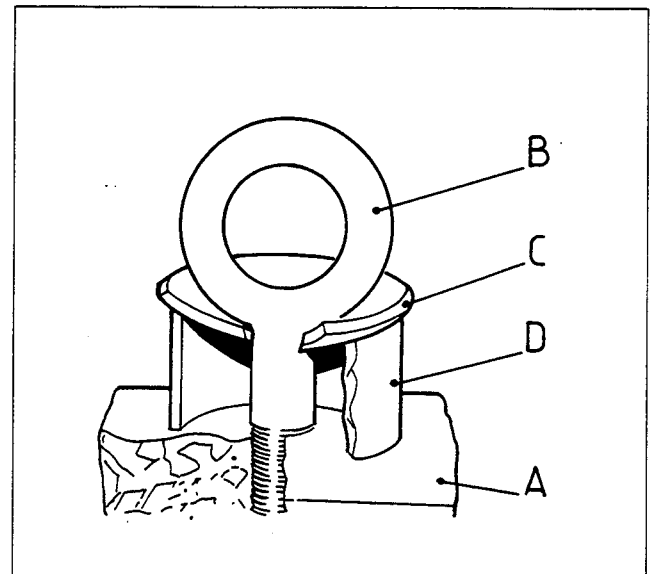
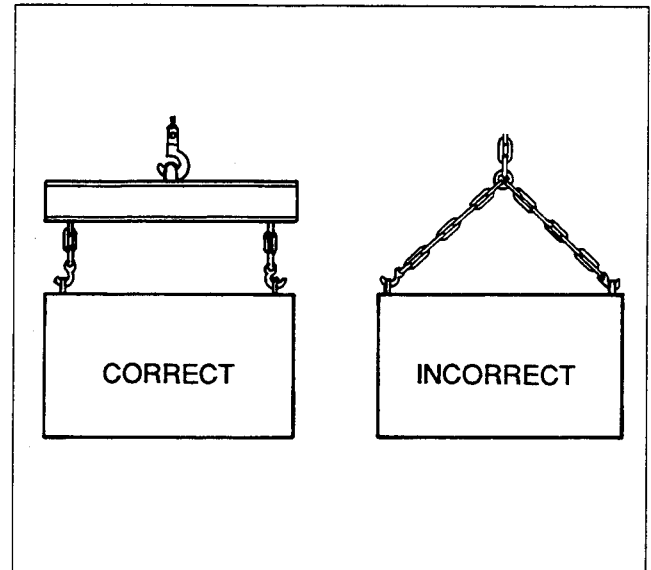

#### Forged eyebolt support

A Load - B Lifting shackle - C Shackle retaining plate (3 mm thick) - D Sleeve (may or may not be welded to plate)

In some cases, special lifting fixtures are available to obtain correct balance and provide for safe handling. Consult the relevant section of the Workshop Manual.

#### Warning

If a part resists removal, check that all nuts and bolts have been removed and that there is no interference from adjacent parts.



1A01.20

## 6100 SERIES TRACTORS



# Introduction

### Cleanliness

To ensure long life of a machine, it is important to keep dirt and foreign material out of its vital working components. Precautions must be taken to safeguard against this. Enclosed compartments, seals and filters have been provided to keep the supply of air, fuel and lubricant clean. These protective devices must not be removed.

Whenever hydraulic fluid, fuel, lubricating oil or air lines are disconnected, clean the point of disconnection and the surrounding area. As soon as a line has been disconnected, cap, plug or tape the line or opening to prevent the ingress of foreign material.

The same cleaning and covering precautions should be taken when access covers or inspection plates are removed.

Clean and inspect all parts. Make sure that all passages and holes are clear. Cover all parts to keep them clean. Make sure parts are clean when they are reassembled. Leave new parts in their wrapping until they are actually needed for reassembly.

### Assembly

When reassembling a machine, complete each step in sequence. Never partially assemble one part then start to assemble another. Make all recommended adjustments. Always check the job on completion to ensure that nothing has been overlooked.

Recheck the various adjustments before putting the machine back into service

*Note : Before fitting new parts, remove rust preventative compound from all machined surfaces (usually «peel-off» substances).*

### Lubrication

Where applicable, fill the compartments of repaired or renewed components with the quantity, type and grade of clean lubricant recommended in the routine maintenance section of the Operation Instruction Book.

### Shims

When shims are removed, tie them together and identify their location. Keep shims clean and take care not to bend them before refitting them.

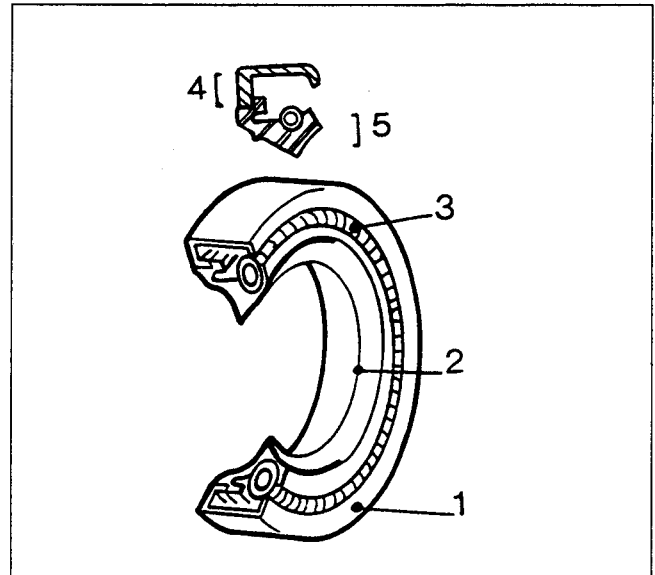

### Gaskets

Make sure that the holes in gaskets line up with lubricating oil passages in the mating parts. If gaskets have to be made, use material of the correct type and thickness. Make sure that holes are punched in the right places.

Incorrectly punched gaskets can cause serious damage.

### Lip type rubber seals.

Lubricate the lips of lip-type seals with oil before fitment. Do not use grease on seals, except for grease seals. The main parts of a lip-type seal are the case (1), the sealing element (2) and the ring spring (3). The figure shows the construction of a simple lip-type seal. The cross section shows the «heel» (4) and the «toe» (5), used to identify the sides of a single element seal. With a few exceptions, the toe of a single-lip seal is located on the lubricant side. Some seals have a second auxiliary lip which has no spring.



## Introduction

### Cables and wires

When removing or disconnecting a group of cables or wires, each one should be identified and labelled in order to ensure that they are correctly refitted.

### Nut and bolt locking devices

The loosening of nuts and bolts is prevented by using lockwashers, tab washers and cotter pins. In addition to these mechanical means, locking agents of the Loctite type are also used.

Flat retainers must be correctly installed in order to be effective. Bend one end of the retainer against the edge of the part. Bend the other end against one of the flats on the nut or bolt head.

Always fit new retainers in compartments which house moving parts. When fitting lockwashers on aluminium housing, place a flat washer between the lockwasher and the housing.

### Lubrication bushes and press fits

Bushes must never be fitted with a hammer alone. Use a suitable fitting tool and a hammer or, better still, a press if possible.

When using a press, ensure that pressure is applied directly in line with the bore. When a lubrication bush has an oil hole, that hole should be aligned with the hole in the mating part.

When press fitting a part into another part, lubricate the mating surfaces. Tapered parts should be assembled dry. Before assembly, check that the tapers are dry, clean and free from burrs.

### Fitting bolts in blind holes

Use bolts of the correct length. A bolt which is too long may "bottom" before the head comes into contact with the part it is intended to hold. This will cause damage to the threads.

If a bolt is too short, there may not be enough threads engaged to hold the part securely, and the bolt is therefore ineffective.

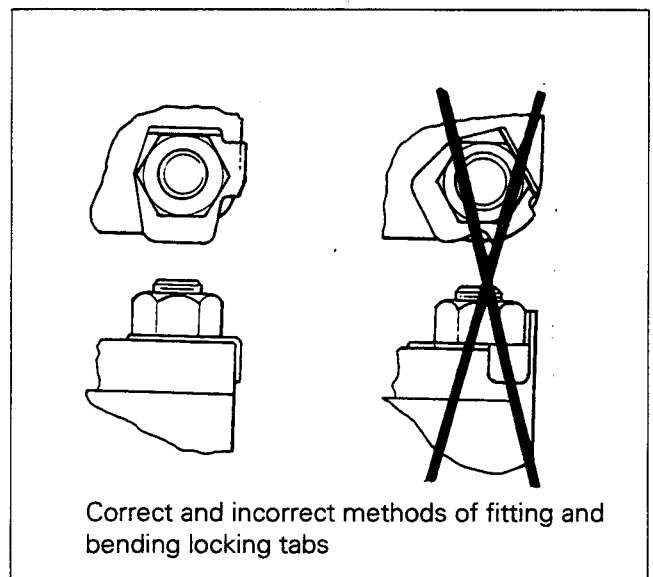
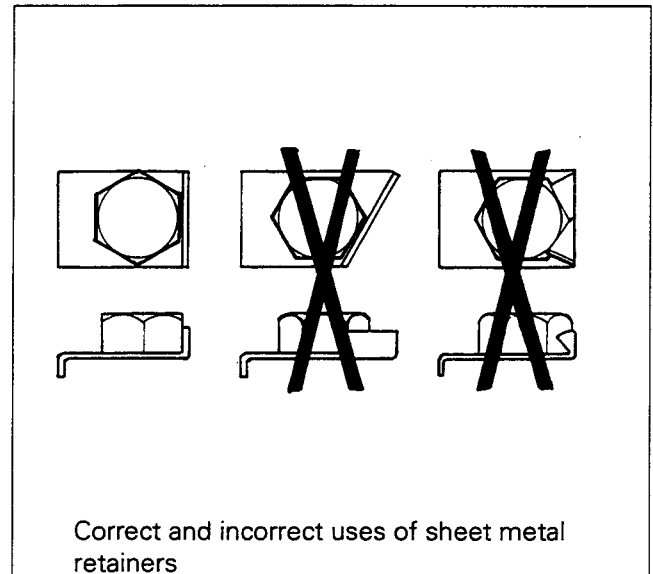



1A01.22

## 6100 SERIES TRACTORS



# Introduction

## F. Installation instructions

### General

In order to ensure regular servicing of the tractor during the warranty period, the supplying MF Distributor or Dealer must carry out the 50-hour and 250-hour servicing operations.

The definition of this operation is designed to provide the tractor with maximum efficiency during the whole warranty period, thus ensuring that it gives reliable service after that period.

### Pre-delivery check

The performance of the following operations must be ensured by the Distributor before delivery to a Dealer and by the Dealer before delivery to an owner or operator.

#### 1. General installation

- Clean the tops of batteries and smear the terminals with petroleum jelly.
- Charge the batteries, if necessary.
- Check all electrical connections, and cable, ducting and light attachments.
- Check and top up the oil levels in the engine and transmission housings.
- Lubricate all grease points.
- Check and adjust belt tensions, as required (alternator, fan, auxiliary pump and air-conditioning compressor).
- Unless it contains an antifreeze compound, flush the cooling system and refill with soft water.
- Check that the fuel tank contains enough fuel of the correct type.
- Check that the cylinder head attaching nuts and bolts are tightened to the required torque. Check that the inlet pipe and exhaust manifold attaching nuts and bolts are correctly tightened.
- Check and adjust the clearance between the valves and rockers and visually check the valve springs.
- Check the injectors, bleed the fuel system and tighten all fuel line connections.
- Check that the engine air filter hoses are secure.
- Check that the engine control linkages are correctly adjusted and operate freely.
- Start the engine.
- Check that the instruments and warning lights operate correctly.
- Check the engine speed on the tachometer with both the hand and foot-operated throttles.
- Hitch up a mounted implement and check that the tractor's hydraulic accessories operate correctly.
- Check and adjust the tyre pressures (road or field work).

- Check the tightness of all nuts, bolts, studs, pipe unions and attachment fittings.
- Check all pipes and hoses for leaks.
- Check that the headlights are correctly adjusted.
- Road test the tractor, checking the correct operation of the brakes and all instruments and accessories.

#### 2. Electronic systems

- Check that the electronic lifting system operates correctly. Carry out the quick check procedure described in section 11D01.
- Check all the Autotronic functions, following the test procedure in section 12B01.
- Check the on-board computer installation in accordance with procedure 13A01.

#### 3. Tightening torques

- Check the tightening torque on the attaching nuts and bolts on the various chassis attachment points:
  - Front axle/engine,
  - Engine/gearbox,
  - Gearbox/rear axle
  - Trumpet sections/rear axle.
- Check the tightening torque of the attaching nuts and bolts on wheels and wheel bodies.





## 6100 SERIES TRACTORS



1A01.23

### Introduction

#### Instructions to driver

Instructions on items listed below must be given to the owner or operator.

1. Safety precautions when starting the engine.
2. Location and significance of tractor and engine serial numbers.
3. Controls and instruments.
4. Running-in.
5. Starting and stopping the engine.
6. Selection of gears and use of gearshift and reverse shuttle levers.
7. Danger of towing down the hill without engine braking and correct use of gearbox.
8. Use and adjustment of brakes and brake pedal latch.
9. Use of the vehicle's clutch.
10. Use of the hydraulic differential lock device.
11. Use of the hydraulic PTO - Clutch and brake.
12. Operation of hydraulic lift system.
13. Hitching and unhitching of towed implements.
14. Grease points.
15. Changing of oil grades.
16. Replacement of engine and transmission filter elements.
17. Operation of fuel system - Bleeding of fuel and injection system - Air filter - Clogging indicator.
18. Cooling system. Frost precautions. Tension of both fan belts.
19. Maintenance of electrical equipment (batteries). System with negative earth.
20. Adjustment of front and rear track.
21. Tyre pressures.
22. Tightness of nuts, bolts and screws.
23. Fuel storage and handling.
24. Use of auxiliary hydraulic equipment.
25. Filling in of tractor and engine serial numbers in the operator instruction book.
26. Reading of the operator instruction book.

### G. Conversion tables

#### Pressure units

1 PSI = 1 lbf/in<sup>2</sup> = 0.0689 bar

1 bar = 14.512 lbf/in<sup>2</sup> = 14.512 PSI

Bar	lbf / in <sup>2</sup>	Bar	lbf / in <sup>2</sup>	Bar	lbf / in <sup>2</sup>
0.5	7.256	9.5	137.9	35	508
1	14.51	10	145	40	588
1.5	21.77	11	159.6	45	653
2	29	12	174	50	726
2.5	36.28	13	189	60	871
3	43.54	14	203	70	1029
3.5	50.8	15	218	80	1161
4	58	16	232	90	1306
4.5	65.3	17	247	100	1451
5	72.6	18	261	200	2903
5.5	79.8	19	276	300	4354
6	87.1	20	290	400	5805
6.5	94.3	21	309	500	7257
7	101.6	22	319	600	8708
7.5	108.8	23	334	700	10160
8	116.1	24	348	800	11611
8.5	123.4	25	368	900	13235
9	130.6	30	435	1000	14514



1A01.24

## 6100 SERIES TRACTORS

**Introduction****Torque units**

1 Nm = 0.7376 lbf/ft

1 lbf/ft = 1.3558 Nm

Nm		lbf/ft	Nm		lbf/ft	Nm		lbf/ft
1.3558	1	0.7376	46.0972	34	25.0784	90.8396	67	49.4912
2.7116	2	1.4752	47.4530	35	25.8160	92.1944	68	50.1568
4.0674	3	2.2128	48.8088	36	26.5536	93.5502	69	50.8944
5.4232	4	2.9504	50.1646	37	27.2912	94.9060	70	51.6320
6.7790	5	3.6880	51.5204	38	28.0288	96.2618	71	52.3696
8.1348	6	4.4256	52.8762	39	28.7664	97.6176	72	53.1072
9.4906	7	5.1632	54.2320	40	29.5040	98.9734	73	53.8448
10.8464	8	5.9008	55.5878	41	30.2416	100.329	74	54.5824
12.2022	9	6.6384	56.9436	42	30.9792	101.685	75	55.3200
13.5580	10	7.3760	58.2994	43	31.7168	103.041	76	56.0576
14.9138	11	8.1136	59.6552	44	32.4544	104.397	77	56.7952
16.2696	12	8.8512	61.0110	45	33.1920	105.752	78	57.5328
17.6254	13	9.5888	62.3668	46	33.9296	107.108	79	58.2704
18.9812	14	10.3264	63.7226	47	34.6672	108.464	80	59.0080
20.3370	15	11.0640	65.0784	48	35.4048	109.820	81	59.7456
21.6928	16	11.8016	66.4342	49	36.1424	111.176	82	60.4832
23.0486	17	12.5392	67.7900	50	36.8800	112.531	83	61.2208
24.4044	18	13.2768	69.1458	51	37.6176	113.887	84	61.9584
25.7602	19	14.0144	70.5016	52	38.3552	115.243	85	62.6960
27.1160	20	14.7520	71.8574	53	39.0928	116.600	86	63.4336
28.4718	21	15.4896	73.2132	54	39.8304	117.955	87	64.1712
29.8276	22	16.2272	74.5690	55	40.5680	119.310	88	64.9088
31.1834	23	16.9648	75.9248	56	41.3056	120.666	89	65.6464
32.5392	24	17.7024	77.2806	57	42.0432	122.022	90	66.3840
33.8950	25	18.4400	78.6364	58	42.7808	123.378	91	67.1216
35.2508	26	19.1776	79.9922	59	43.5184	124.734	92	67.8592
36.6066	27	19.9152	81.3480	60	44.2560	126.089	93	68.5968
37.9624	28	20.6528	82.7038	61	44.9936	127.445	94	69.3344
39.3182	29	21.3904	84.0596	62	45.7312	128.801	95	70.0720
40.6740	30	22.1280	85.4154	63	46.4688	130.157	96	70.8096
42.0298	31	22.8656	86.7712	64	47.2064	131.513	97	71.5472
43.3856	32	23.6032	88.1270	65	47.9440	132.868	98	72.2848
44.7414	33	24.3408	89.4828	66	48.6816	134.224	99	73.0224



## 6100 SERIES TRACTORS



1A01.25

### Introduction

#### Capacity units

1 litre = 0.2199 imp. gallon

1 imp. gallon = 4.5459 litres

#### Note:

1 US gallon = 3.79 litres

Imp. gal.		Litres	Imp. gal.		Litres	Imp. gal.		Litres
0.2199	1	4.5459	7.4766	34	154.561	14.733	67	304.575
0.4398	2	9.0918	7.6965	35	159.107	14.9532	68	309.121
0.6597	3	13.6377	7.9164	36	163.652	15.1731	69	313.667
0.8796	4	18.1836	8.1363	37	168.198	15.3930	70	318.213
1.0995	5	22.7295	8.3562	38	172.744	15.6129	71	322.759
1.3194	6	27.2754	8.5761	39	177.290	15.8328	72	327.305
1.5393	7	31.8213	8.7960	40	181.836	16.0527	73	331.851
1.7592	8	36.3672	9.0159	41	186.382	16.2726	74	336.397
1.9791	9	40.9131	9.2358	42	190.929	16.4925	75	340.943
2.1990	10	45.4590	9.4557	43	195.474	16.7124	76	345.488
2.4189	11	50.0049	9.6756	44	200.019	16.9323	77	350.034
2.6388	12	54.5508	9.8955	45	204.566	17.1522	78	354.580
2.8587	13	59.0967	10.1154	46	209.111	17.3721	79	359.126
3.0786	14	63.6426	10.3353	47	213.657	17.5920	80	363.672
3.2985	15	68.1885	10.5552	48	218.203	17.8119	81	368.218
3.5184	16	72.7344	10.7751	49	222.749	18.0318	82	372.764
3.7383	17	77.2803	10.9950	50	227.295	18.2517	83	377.310
3.9582	18	81.8262	11.2149	51	231.841	18.4716	84	381.856
4.1781	19	86.3721	11.4348	52	236.387	18.6915	85	386.402
4.3980	20	90.9180	11.6547	53	240.933	18.9114	86	390.947
4.6179	21	95.4639	11.8746	54	245.479	19.1313	87	395.493
4.8378	22	100.009	12.0945	55	250.025	19.3512	88	400.039
5.0577	23	104.556	12.3144	56	254.570	19.5711	89	404.585
5.2776	24	109.102	12.5343	57	259.116	19.7910	90	409.131
5.4975	25	113.648	12.7542	58	263.662	20.0109	91	413.677
5.7174	26	118.193	12.9741	59	268.209	20.2308	92	418.223
5.9373	27	122.739	13.1940	60	272.754	20.4507	93	422.769
6.1572	28	127.285	13.4139	61	277.299	20.6706	94	427.315
6.3771	29	131.831	13.6338	62	281.846	20.8905	95	431.861
6.5970	30	136.377	13.8537	63	286.392	21.1104	96	436.406
6.8169	31	140.923	14.0736	64	290.938	21.3303	97	440.952
7.0368	32	145.469	14.2935	65	295.483	21.5502	98	445.498
7.2567	33	150.015	14.5134	66	300.029	21.7701	99	450.044



1A01.26

## 6100 SERIES TRACTORS

**Introduction****Capacity units**

1 litre = 1.7599 imp. pints

1 imp. pint = 0.5682 litre

**Note:**

1 litre = 2.113 US pints

Imp. pt.		Litres	Imp. pt.		Litres	Imp. pt.		Litres
1.7599	1	0.5682	59.8366	34	19.3188	117.913	67	38.0694
3.5198	2	1.1364	61.5965	35	19.8870	119.673	68	38.6376
5.2797	3	1.7046	63.3564	36	20.4552	121.433	69	39.2058
7.0396	4	2.2728	65.1163	37	21.0234	123.193	70	39.7740
8.7995	5	2.8400	66.8762	38	21.5916	124.953	71	40.3422
10.5594	6	3.4902	68.6361	39	22.1598	126.713	72	40.9104
12.3193	7	3.9774	70.3960	40	22.7280	128.473	73	41.4786
14.0792	8	4.5456	72.1559	41	23.2962	130.233	74	42.0468
15.8391	9	5.1138	73.9158	42	23.8644	131.993	75	42.6150
17.5990	10	5.6820	75.6757	43	24.4326	133.752	76	43.1832
19.3589	11	6.2502	77.4356	44	25.0008	135.512	77	43.7514
21.1188	12	6.8184	79.1955	45	25.5690	137.272	78	44.3196
22.8787	13	7.3866	80.9554	46	26.1372	139.032	79	44.8878
24.6386	14	7.9548	82.7153	47	26.7054	140.792	80	45.4560
26.3985	15	8.5230	84.4752	48	27.2736	142.552	81	46.0242
28.1854	16	9.0912	86.2351	49	27.8418	144.312	82	46.5924
29.9183	17	9.6594	87.9950	50	28.4100	146.072	83	47.1606
31.6782	18	10.2276	89.7549	51	28.9782	147.832	84	47.7288
33.4381	19	10.7958	91.5148	52	29.5464	149.592	85	48.2970
35.1980	20	11.3640	93.2747	53	30.1146	151.351	86	48.8652
36.9579	21	11.9322	95.0346	54	30.6828	153.111	87	49.4334
38.7178	22	12.5004	96.7945	55	31.2510	154.871	88	50.0016
40.4770	23	13.0686	98.5544	56	31.8192	156.631	89	50.5698
42.2376	24	13.6368	100.314	57	32.3874	158.391	90	51.1380
43.9975	25	14.2050	102.074	58	32.9556	160.151	91	51.7062
45.7574	26	14.7732	103.834	59	33.5238	161.912	92	52.2744
57.5173	27	15.3414	105.594	60	34.0920	163.671	93	52.8426
49.2772	28	15.9096	107.354	61	34.6602	165.431	94	53.4108
51.0371	29	16.4778	109.114	62	35.2284	167.191	95	53.9790
52.7970	30	17.0460	110.874	63	35.7966	168.950	96	54.5472
54.5569	31	17.6142	112.634	64	36.3648	170.710	97	55.1154
56.3168	32	18.1824	114.394	65	36.9330	172.470	98	55.6836
58.0767	33	18.7506	116.153	66	37.5012	174.230	99	56.2518



# 6100 SERIES TRACTORS



1A01.27

## Introduction

### Length units

1 m = 3.2808 ft

1 ft = 0.3048 m

m		ft	m		ft	m		ft
0.3048	1	3.2808	10.3632	34	111.549	20.4216	67	219.816
0.6096	2	6.5617	10.6680	35	114.829	20.7264	68	223.097
0.9144	3	9.8425	10.9728	36	118.110	21.0312	69	226.378
1.2192	4	13.1234	11.2776	37	121.391	21.3360	70	229.659
1.5240	5	16.4042	11.5824	38	124.672	21.6408	71	232.940
1.8288	6	19.6850	11.8872	39	127.953	21.9456	72	236.220
2.1336	7	22.9659	12.1920	40	131.234	22.2504	73	239.501
2.4384	8	26.2467	12.4968	41	134.514	22.5552	74	242.782
2.7432	9	29.5276	12.8016	42	137.795	22.8600	75	246.063
3.0480	10	32.8084	13.1064	43	141.076	23.1648	76	249.344
3.3528	11	36.0892	13.4112	44	144.357	23.4696	77	252.625
3.6576	12	39.3701	13.7160	45	147.638	23.7744	78	255.906
3.9624	13	42.6509	14.0208	46	150.919	24.0792	79	259.186
4.2672	14	45.9318	14.3256	47	154.199	24.3840	80	262.467
4.5720	15	49.2126	14.6304	48	157.480	24.6888	81	265.748
4.8768	16	52.4934	14.9352	49	160.761	24.9936	82	269.029
5.1816	17	55.7743	15.2400	50	164.042	25.2984	83	272.310
5.4864	18	59.0551	15.5448	51	167.323	25.6032	84	275.591
5.7912	19	62.3360	15.8496	52	170.604	25.9080	85	278.871
6.0960	20	65.6168	16.1544	53	173.885	26.2128	86	282.152
6.4008	21	68.8976	16.4592	54	177.165	26.5176	87	285.433
6.7056	22	72.1785	16.7640	55	180.446	26.8224	88	288.714
7.0104	23	75.4593	17.0688	56	183.727	27.1272	89	291.995
7.3152	24	78.7402	17.3736	57	187.008	27.4320	90	295.276
7.6200	25	82.0210	17.6784	58	190.289	27.7368	91	298.556
7.9248	26	85.3018	17.9832	59	193.570	28.0416	92	301.837
8.2296	27	88.5827	18.2880	60	196.850	28.3464	93	305.118
8.5344	28	91.8635	18.5928	61	200.131	28.6512	94	308.399
8.8392	29	95.1444	18.8976	61	203.412	28.9560	95	311.680
9.1440	30	98.4252	19.2024	63	206.693	29.2608	96	314.961
9.4488	31	101.7060	19.5072	64	209.974	29.5656	97	318.241
9.7536	32	104.9870	19.8120	65	213.255	29.8704	98	321.522
10.0584	33	108.2680	20.1168	66	216.535	30.1752	99	324.803



1A01.28

## 6100 SERIES TRACTORS



### Introduction

#### Weight units

1 kg = 2.2046 lb

1 lb = 0.4536 kg

kg		lb	kg		lb	kg		lb
0.4536	1	2.2046	15.4224	34	74.9564	30.3912	67	147.708
0.9072	2	4.4092	15.8760	35	77.1610	30.8448	68	149.913
1.3608	3	6.6138	16.3296	36	79.3656	31.2984	69	152.117
1.8144	4	8.8184	16.7832	37	81.5702	31.7520	70	154.322
2.2680	5	11.0230	17.2368	38	83.7748	32.2056	71	156.527
2.7216	6	13.2276	17.6904	39	85.9794	32.6592	72	158.731
3.1752	7	15.4322	18.1440	40	88.1840	33.1128	73	160.936
3.6288	8	17.6368	18.5976	41	90.3886	33.5664	74	163.140
4.0824	9	19.8414	19.0512	42	92.5932	34.0200	75	165.345
4.5360	10	22.0460	19.5048	43	94.7978	34.4736	76	167.549
4.9896	11	24.2506	19.9584	44	97.0024	34.9272	77	169.754
5.4432	12	26.4552	20.4120	45	99.207	35.3808	78	171.958
5.8968	13	28.6598	20.8656	46	101.412	35.8344	79	174.163
6.3504	14	30.8644	21.3192	47	103.616	36.2880	80	176.368
6.8040	15	33.0690	21.7728	48	105.821	36.7416	81	178.573
7.2576	16	35.2736	22.2264	49	108.025	37.1952	82	180.777
7.7112	17	37.4782	22.6800	50	110.230	37.6488	83	182.982
8.1648	18	39.6828	23.1336	51	112.435	38.1024	84	185.186
8.6184	19	41.8874	23.5872	52	114.639	38.5560	85	187.391
9.0720	20	44.0920	24.0408	53	116.844	39.0096	86	189.596
9.5256	21	46.2966	24.4944	54	119.048	39.4632	87	191.800
9.9792	22	48.5012	24.9489	55	121.253	39.9168	88	194.005
10.4328	23	50.7058	25.4016	56	123.458	40.3704	89	196.209
10.8864	24	52.9104	25.8552	57	125.662	40.8240	90	198.414
11.3400	25	55.1150	26.3088	58	127.867	41.2776	91	200.619
11.7936	26	57.3196	26.7624	59	130.071	41.7312	92	202.823
12.2472	27	59.5242	27.2160	60	132.276	42.1848	93	205.028
12.7008	28	61.7288	27.6696	61	134.481	42.6384	94	207.232
13.1544	29	63.9334	28.1232	62	136.685	43.0920	95	209.437
13.6080	30	66.1380	28.5768	63	138.889	43.5456	96	211.642
14.0616	31	68.3426	29.0304	64	141.094	43.9992	97	213.846
14.5152	32	70.5472	29.4840	65	143.299	44.4528	98	216.051
16.9688	33	72.7518	29.9376	66	145.504	44.9064	99	218.255



## Introduction

### Conversion table

Fractions of inches	LENGTHS 1 inch = 25.4 mm						TEMPERATURE			
	Decimals	mm	Inches to mm		mm to inches		Fahrenheit to Celsius			
			Inches	mm	mm	Inches	° F	° C	° C	° F
1/64	.015625	0.3969					- 20	- 28.9	- 30	- 22
1/32	.031250	0.7937					- 15	- 26.1	- 28	- 18.4
3/64	.468750	1.1906					- 10	- 23.3	- 26	- 14.8
1/16	.062500	1.5875	0.0001	0.00254	0.004	0.00015	- 5	- 20.6	- 24	- 11.2
5/64	.078125	1.9844	.0002	.00508	0.005	.00019	0	- 17.8	- 22	- 7.6
3/32	.093750	2.3812	.0003	.00762	0.006	.00023	1	- 17.2	- 20	- 4
7/64	.109375	2.7781	.0004	.01016	0.007	.00027	2	- 16.7	- 18	- 0.4
1/8	.125000	3.1750	.0005	.01270	0.008	.00031	3	- 16.1	- 16	3.2
9/64	.140625	3.5719	.0006	.01524	0.009	.00035	4	- 15.6	- 14	6.8
5/32	.156250	3.9687	.0007	.01778	0.01	.00039	5	- 15.0	- 12	10.4
11/64	.171875	4.3656	.0008	.02032	0.02	.00079	10	- 12.2	- 10	14
3/16	.187500	4.7625	.0009	.02286	0.03	.00118	15	- 9.4	- 8	17.6
13/64	.203125	5.1594	.001	.0254	0.04	.00157	20	- 6.7	- 6	21.2
7/32	.218750	5.5562	.002	.0508	0.05	.00197	25	- 3.9	- 4	24.8
15/64	.234375	5.9531	.003	.0762	0.06	.00236	30	- 1.1	- 2	28.4
1/4	.250000	6.3500	.004	.1016	0.07	.00276	35	1.7	0	32
17/64	.265625	6.7469	.005	.1270	0.08	.00315	40	4.4	2	35.6
9/32	.281250	7.1437	.006	.1524	0.09	.00354	45	7.2	4	39.2
19/64	.296875	7.5406	.007	.1778	0.10	.00394	50	10.0	6	42.8
5/16	.312500	7.9375	.008	.2032	0.20	.0078	55	12.8	8	46.4
21/64	.328125	8.3344	.009	.2286	0.30	.01181	60	15.6	10	50
11/32	.343750	8.7312	.01	.254	0.40	.01575	65	18.3	12	53.6
23/64	.359375	9.1281	.02	.508	0.50	.01969	70	21.1	14	57.2
3/8	.375000	9.5250	.03	.762	0.60	.02362	75	23.9	16	60.8
25/64	.390625	9.9219	.04	1.016	0.70	.02756	80	26.7	18	64.4
13/32	.406250	10.3187	.05	1.270	0.80	.03149	85	29.4	20	68
27/64	.421875	10.7156	.06	1.524	0.90	.03543	90	32.2	22	71.6
7/16	.437500	11.1125	.07	1.778	1	.03937	95	35.0	24	75.2
29/64	.453125	11.5094	.08	2.032	2	.07874	100	37.8	26	78.8
15.32	.468750	11.9062	.09	2.286	3	.11811	105	40.6	28	82.4
31/64	.484375	12.3031	.10	2.540	4	.15748	110	43.3	30	86
1/2	.500000	12.7000	.20	5.080	5	.19685	115	46.1	32	89.6
33/64	.515625	13.0969	.30	7.620	6	.23622	120	48.9	34	93.2
17/32	.53125	13.4937	.40	10.160	7	.27559	125	51.7	36	96.8



# 6100 SERIES TRACTORS



1A01.30

## Introduction

LENGTHS 1 inch = 25.4 mm							TEMPERATURE			
Fractions of inches	Decimals	mm	Inches to mm		mm to inches		Fahrenheit to Celsius			
			Inches	mm	mm	Inches	° F	° C	° C	° F
35/64	.546875	13.8906	0.5	12.70	8	0.31496	130	54.4	38	100.4
9/16	.562500	14.2875	.6	15.24	9	.35433	135	57.2	40	104
37/64	.578125	14.6844	.7	17.78	10	.39370	140	60.0	42	107.6
19/32	.593750	15.0812	.8	20.32	11	.43307	145	62.8	44	112.2
39/64	.609375	15.4781	.9	22.86	12	.47244	150	65.6	46	114.8
5/8	.6250	15.8750	1	25.4	13	.51181	155	68.3	48	118.4
41/64	.640625	16.2719	2	50.8	14	.55118	160	71.1	50	122
21/32	.656250	16.6687	3	76.2	15	.59055	165	73.9	52	125.6
43/64	.671875	17.0656	4	101.6	16	.62992	170	76.7	54	129.2
11/16	.687500	17.4625	5	127	17	.66929	175	79.4	56	132.8
45/64	.703125	17.8594	6	152.4	18	.70866	180	82.2	58	136.4
23/32	.718750	18.2562	7	177.8	19	.74803	185	85.0	60	140
47/64	.734375	18.6531	8	203.2	20	.78740	190	87.8	62	143.6
3/4	.7500	19.05	9	228.6	21	.82677	195	90.6	64	147.2
49/64	.765625	19.4469	10	254	22	.86614	200	93.3	66	150.8
25/32	.781250	19.8437	11	279.4	23	.90551	205	96.1	68	154.4
51/64	.796875	20.2406	12	304.8	24	.94480	210	98.9	70	158
13/16	.812500	20.6375	13	330.2	25	.98425	212	100.0	75	167
53/64	.828125	21.0344	14	355.6	26	1.02362	215	101.7	80	176
27/32	.843750	21.4312	15	381	27	1.06299	220	104.4	85	185
55/64	.859375	21.8281	16	406.4	28	1.10236	225	107.2	90	194
7/8	.875000	22.2250	17	431.8	29	1.14173	230	110.0	95	203
57/64	.890625	22.6219	18	457.2	30	1.18110	235	112.8	100	212
29/32	.906250	23.0187	19	482.6	31	1.22047	240	115.6	105	221
59/64	.921875	23.4156	20	508	32	1.25984	245	118.3	110	230
15/16	.937500	23.8125	21	533.4	33	1.29921	250	121.1	115	239
61/64	.953125	24.2094	22	558.8	34	1.33858				
31/32	.968750	24.6062	23	584.2	34	1.37795				
63/64	.984375	25.0031	24	609.6	36	1.41732				
1	1.00	25.40	25	635	37	1.45669				
			26	660.4	38	1.49606				
					39	1.53543				
					40	1.57480				





## Introduction

### H. Locking compounds and sealants

The Loctite compounds mentioned in this manual are referred to by their industrial names.

For the purposes of repairs, use their commercial names or the corresponding MF references as per the following chart.

Loctite industrial name	Commercial	MF reference
242 - 241 - 542	Lock and Seal	1 633 266 M1
270	Stud lock	1 633 267 M1
510 - 221	Instant Gasket Retainer	1 633 270 M2
638 - 648	Superflex sealant.	1 633 268 M1
Silicomet	R.T.V. silicone sealant (clear)	3 405 423 M1

**Note: Use the product "Form A gasket 2" when sealing between plastic material and iron (or steel).**

**Examples: PTO sensor, vehicle speed sensor, etc..**

These products can be ordered from the following address:

FRAMET  
10 Avenue Eugène Gazeau  
Zone Industrielle  
60304 - SENLIS  
FRANCE

#### Application method for Loctite products

- Remove all traces of previous sealants and corrosion
  - by mechanical process: wire brush or emery cloth,
  - by chemical action: "DECAPLOC 88".
 Leave the product to take effect and then wipe clean.
- Degrease the components with dry solvent
  - preferably, use "LOCTITE 706 Dry Super Solvent".
- Allow the solvents to evaporate.
- Apply the recommended type of LOCTITE sealant on the parts:
  - For blind tapped holes: apply a quantity of product on the last threads at the bottom of the hole.
  - For cylindrical fitting components, apply compound on both mating surfaces with a clean brush.

- For gasket faces, apply a bead on one of the two faces, passing around the holes, and then tighten as quickly as possible.

#### Note:

**a) Do not use too much of the compound in order to avoid locking adjacent parts.**

**b) Do not attempt to retighten after 5 minutes of curing in order to avoid breaking the film of compound.**

**c) If the ambient temperature is less than +10°C, and to ensure quicker setting of Loctite compounds (except for SILICOMET), use LOCTITE T 747 activator on at least one of the two parts.**

**Excess sealant outside the joint will not harden (anaerobic curing of compound - i.e. curing occurs only in absence of oxygen).**

#### Grease

When grease is used in components which are in contact with transmission oil, use a grease which is miscible with oil to avoid clogging the hydraulic filters.

Use "Amber Technical" grease supplied by WITCO company, 76320 Saint-Pierre des Elfes, France.

### I. Tightening torques

When tightening nuts and bolts, use the recommended tightening torques as per the charts:

- **1** and **2** : for metric threads,
- **3** and **4** : for inch threads.

When a specific torque is required, it is mentioned in the text.

Charts 1 and 3 specify the standard tightening torque values applicable to zinc-plated threaded elements with standard nuts with coarse or fine thread, with or without flat washers or lockwashers, and weld nuts deeper than 0.8 d.

Charts 2 and 4 specify the reduced tightening torque values applicable to threaded fasteners in assemblies with self-locking zinc-plated nuts, phosphated nuts or bolts, shallow nuts and weld nuts shallower than 0.8 d.

These values are applicable to dry assemblies. If the threads are oiled, reduce the tightening torques.

**Note: Read the strength classification on the bolt head and determine the required torque loading.**

Example:

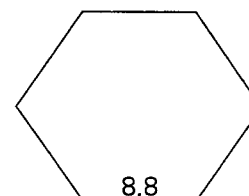



1A01.32

## 6100 SERIES TRACTORS

**Introduction****Chart 1**

Tightening torque values: zinc-plated metric threads

Nominal dimension d.	Strength classification		Strength classification	
	ISO 8.8 (SAE 5, BS S)		ISO 10.9 (SAE 8, BS V)	
	Torque Nm		Torque Nm	
	Max.	Min.	Max.	Min.
M3	1.7	1.3	2.4	1
M4	4.1	3.1	5.7	4
M5	8	6	11.5	8
M6	14	10	20	14
M8	35	25	46	36
M10	70	50	96	72
M12	120	90	160	120
M16	260	200	400	300
M20	560	420	800	600
M24	960	720	1300	1000
M30	1800	1400	2800	2100
M36	3300	2500	4800	3600

**Chart 2**

Reduced tightening torque values: metric threads

Nominal dimension d.	Strength classification		Strength classification	
	ISO 8.8 (SAE 5, BS S)		ISO 10.9 (SAE 8, BS V)	
	Torque Nm		Torque Nm	
	Max.	Min.	Max.	Min.
M3	1.4	1	1.9	1
M4	3.3	2.5	4.6	3
M5	6.4	4.8	9.2	6
M6	11	8	16	12
M8	28	20	37	29
M10	56	40	77	57
M12	96	72	130	100
M16	210	160	320	240
M20	450	340	640	480
M24	770	570	1040	800
M30	1400	1100	2200	1700
M36	2600	2000	3800	2900



# 6100 SERIES TRACTORS



1A01.33

## Introduction

### Chart 3

Tightening torque values: zinc-plated threads in inches

Nominal dimension d.	Strength classification		Strength classification	
	SAE 5 (ISO 8.8 BS S)		SAE 8 (ISO 10.9 BS V)	
	Torque Nm		Torque Nm	
	Max.	Min.	Max.	Min.
#6	2.4	1.8	3.3	2
#8	4.4	3.4	6.3	4
#10	6.3	4.7	8.9	6
1/4	15	11	22	16
5/16	30	22	43	31
3/8	53	39	75	55
7/16	86	64	120	90
1/2	130	100	180	140
5/8	260	200	370	280
3/4	460	350	660	490
7/8	760	560	1060	800
1	1120	840	1600	1200
1 1/8	1390	1050	2200	1700
1 1/4	2000	1500	3200	2400
1 1/2	3400	2600	5400	4100

### Chart 4

Reduced tightening torque values: zinc-plated threads in inches

Nominal dimension d.	Strength classification		Strength classification	
	SAE 5 (ISO 8.8 BS S)		SAE 8 (ISO 10.9 BS V)	
	Couple Nm		Couple Nm	
	Max.	Min.	Max.	Min.
#6	1.9	1.5	2.6	2
#8	3.5	2.7	5	3
#10	5	3.8	7.1	5
1/4	12	8.8	18	13
5/16	24	18	34	25
3/8	42	31	60	44
7/16	69	51	96	72
1/2	104	80	140	110
5/8	210	160	300	220
3/4	370	280	530	390
7/8	610	450	850	640
1	900	670	1280	960
1 1/8	1100	840	1760	1360
1 1/4	1600	1200	2560	1920
1 1/2	2700	2100	4320	3280





## **2 . SPLITTING THE TRACTOR**

### **Contents**

- 2 A01 SPLITTING THE TRACTOR BETWEEN THE ENGINE AND THE GEARBOX**
- 2 B01 SPLITTING THE TRACTOR BETWEEN THE GEARBOX AND THE REAR AXLE**
- 2C01 SPLITTING THE TRACTOR BETWEEN THE FRONT SUPPORT AND THE ENGINE**





*2 A01 Splitting the tractor between the engine and the gearbox*

CONTENTS

<b>A. Uncoupling</b>	_____	<b>2</b>
<b>B. Recoupling</b>	_____	<b>3</b>
<b>C. Service tool</b>	_____	<b>4</b>



2A01.2

## 6100 SERIES TRACTORS

**Splitting the tractor - Engine / gearbox****A. Uncoupling**

1. Disconnect the two front differential lock (4WD) control hoses. Plug the pipe connections.
2. Remove the guard and the 4WD drive shaft.
3. Remove the sheet metal panels.
4. Disconnect the earth cables only from the batteries.
5. Remove the hood rear bracket.
6. Disconnect and plug:
  - the two Orbitrol steering ram hoses (and mark their position),
  - the two air conditioning connections using plugs No. 3376935M91 (Section C), (according to option fitted), and remove the bracket,
  - the diesel fuel return hose,
  - the two cooler hoses on the 17-bar valve (and mark their positions),
  - the accelerator control on the injection pump,
  - the flowmeter harness (if fitted),
  - the main wiring harness connections above the engine,
  - the heating hoses (plug the openings to avoid draining the cooling system completely),
  - the 7.5 A and 10 A fuse harness (to release this harness, slightly loosen the right-hand bar above the radiator),
  - the diesel fuel supply hose.
7. Immobilise the tractor:
  - apply the handbrake,
  - fit wedges between the frame and the front axle (Fig. 1).
8. Support the tractor under the gearbox using a stand.
9. Support the tractor under the sump using a stand.
10. Remove the toolbox and take out the two bolts (1) from the shock absorbers on the right-hand and left-hand cab supports. Slightly raise the cab and fit wedges (4-cylinder engine). (See Fig. 2).
11. Loosen the bolts attaching the engine to the gearbox.
12. Separate the gearbox from the engine.

**Note: As a safety measure, remove the front weights.**

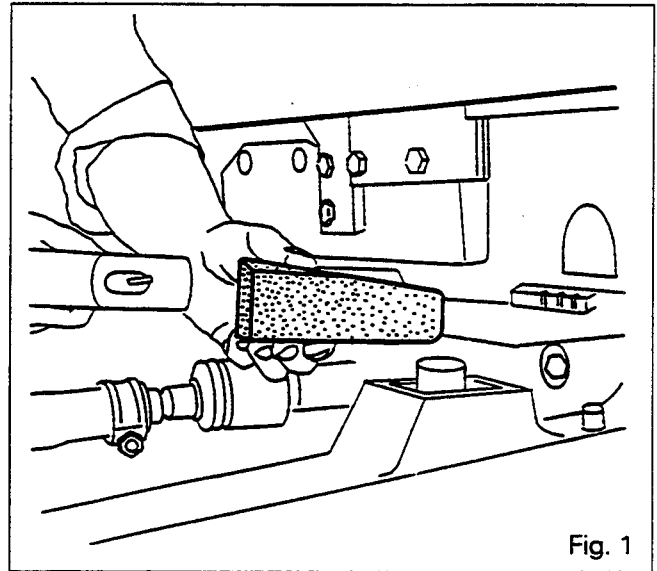

Fig. 1

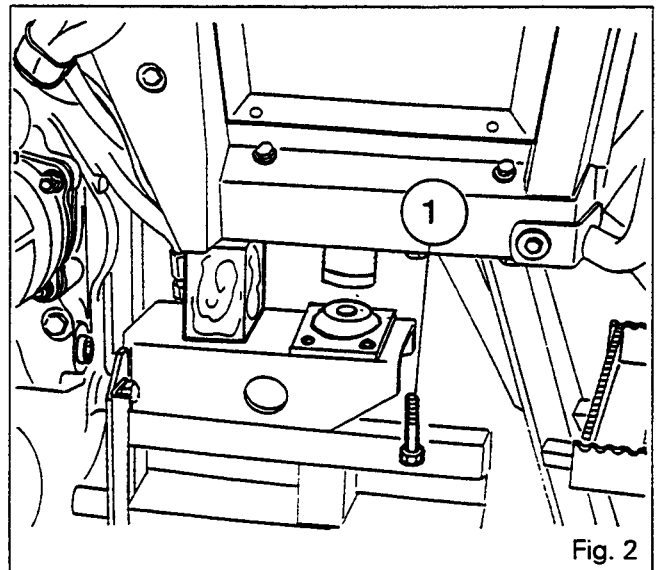

Fig. 2





## Splitting the tractor - Engine / gearbox

2A01.3

### B . Recoupling

**Note:** Tractors of types 6170 to 6180 from serial number F058049 onwards and 6190 tractors (pressure-loaded clutch) are equipped with a damper (6) (Fig. 3B) different from the one fitted on the version with a spring-loaded clutch (Fig. 3A).

13. Screw two dowels (locally manufactured) in diametrically opposite positions on the gearbox (except for 6150 series tractors).
14. Lightly grease the splines on the shaft (7) (Fig. 3A and 3B) (grease of type GN + Molykote) and slide the bush (9) onto the shaft as shown in Fig. 3A (tractor with spring-loaded clutch and spacer between engine and gearbox).
15. Check that the two locating pins are fitted on the engine.
16. Fit the engine to the gearbox by turning the flywheel ring gear with a screwdriver.
17. For 6-cylinder engines, smear the bolts with Loctite 270.  
Tighten the bolts (Figures 4 and 5):  
**4-cylinder engines**  
- 1 to 15: 100 to 130 Nm  
**6-cylinder engines**  
- 1 - 3 - 4 - 11 - 12: 120 to 160 Nm  
- 2 - 5 - 10 - 13 - 14 - 15: 300 to 400 Nm  
- 6 - 7 - 8 - 9: 600 to 800 Nm
18. Position the cab on its supports, making sure that the balls of the gear lever and reversing lever (if fitted) are correctly fitted in their respective bell housings. Fit the bolts (1) on the shock absorbers (Fig. 2) and tighten them to a torque of 200 to 270 Nm.
19. Carry out procedures 4 to 9 in reverse order.
20. Top up the radiator.
21. Refit the 4WD drive shaft and the guard, and reconnect the hoses for the differential lock control.
22. Reset the electric reverse shuttle control system (if fitted).
23. Check the accelerator control setting.
24. Check:
  - the hydraulic systems for leaks,
  - the correct operation of electrical circuits.
25. Reinstall the sheet metal panels.
26. Carry out road test.

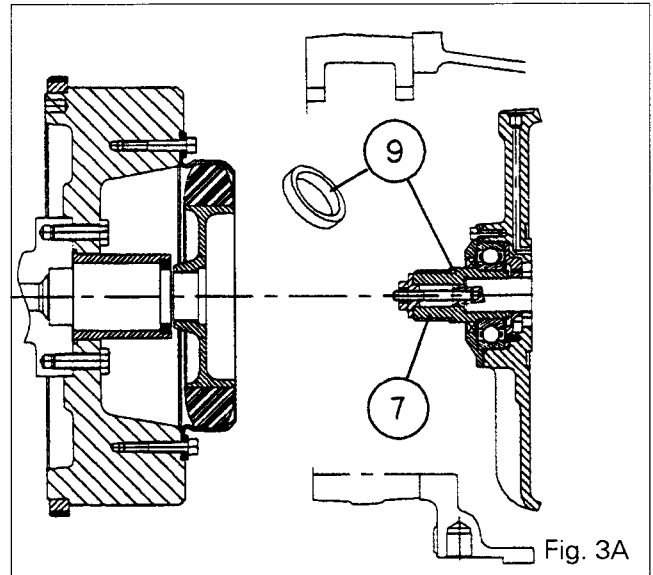

Fig. 3A

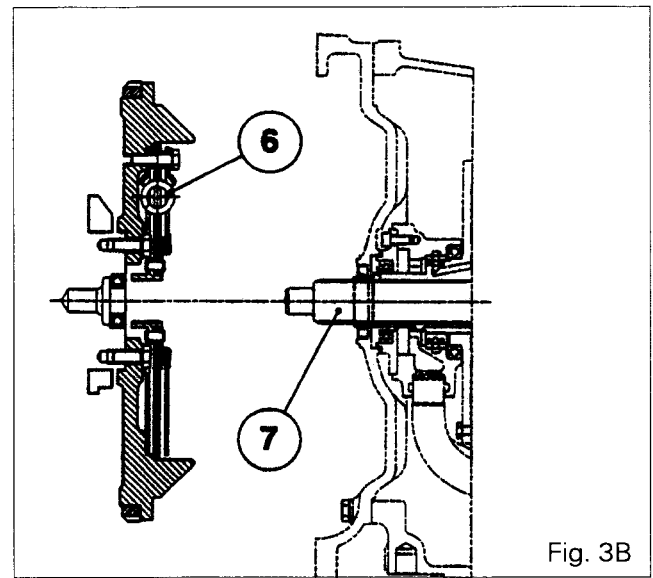

Fig. 3B

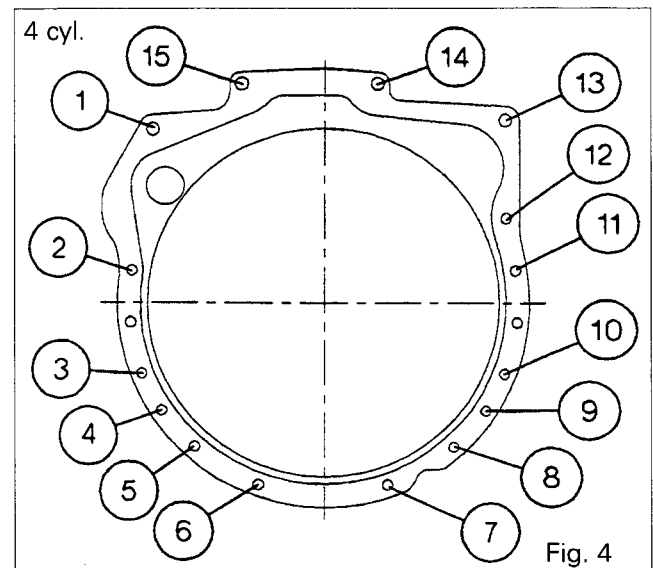

Fig. 4



2A01.4

# 6100 SERIES TRACTORS



## Splitting the tractor - Engine / gearbox

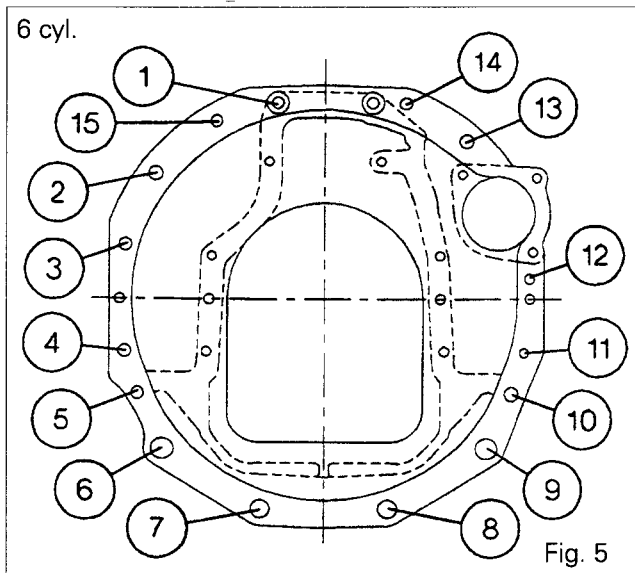

### C . Service tool

3376935M91 - Set of plugs for air conditioning couplings

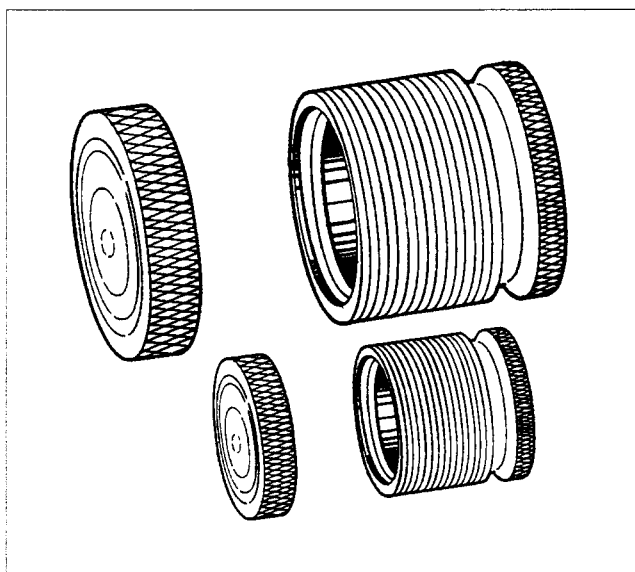



*2 B01 Splitting the tractor between the gearbox  
and the rear axle (cab integral with rear axle)*

CONTENTS

<b>A. Uncoupling</b>	_____	<b>2</b>
<b>B. Recoupling</b>	_____	<b>4</b>
<b>C. Service tool</b>	_____	<b>5</b>



2B01.2

## 6100 SERIES TRACTORS

**Splitting the tractor - Gearbox / rear axle****A. Uncoupling**

1. Immobilise the tractor. Apply the handbrake. Fit wedges between the frame and the axle (Fig. 1).
2. Disconnect the front differential lock (4WD) control hoses and plug the pipe connections.
3. Remove the guard and the 4WD drive.
4. Remove the sheet metal panels and the exhaust pipe.
5. Disconnect the earth cables only from the batteries.
6. Remove the hood rear bracket.
7. Disconnect and plug:
  - the two Orbital steering ram hoses (and mark their position),
  - the two air conditioning connections using plugs No. 3376935M91 (Section C), (according to option fitted), and remove the bracket,
  - the diesel fuel return hose,
  - the two cooler hoses on the 17-bar valve (and mark their positions),
  - the accelerator control on the injection pump,
  - the flowmeter harness (if fitted),
  - the main wiring harness connections above the engine,
  - the diesel fuel supply hose,
  - the heating hoses.
8. Plug the openings to avoid draining the cooling system completely.
9. Drain the oil from the gearbox and the rear axle.
10. Disconnect and plug the following tubes or hoses:
  - the power take-off clutch lubricating tube,
  - the gearbox lubricating hose,
  - the return hose,
  - the engine clutch lubricating hose from the master cylinder to the control valve (pressure-loaded type) or to the gearbox (spring-loaded type).
11. Remove the earth braid from the right-hand cab support.
12. Remove the right-hand guard protecting the controls and solenoid valves.

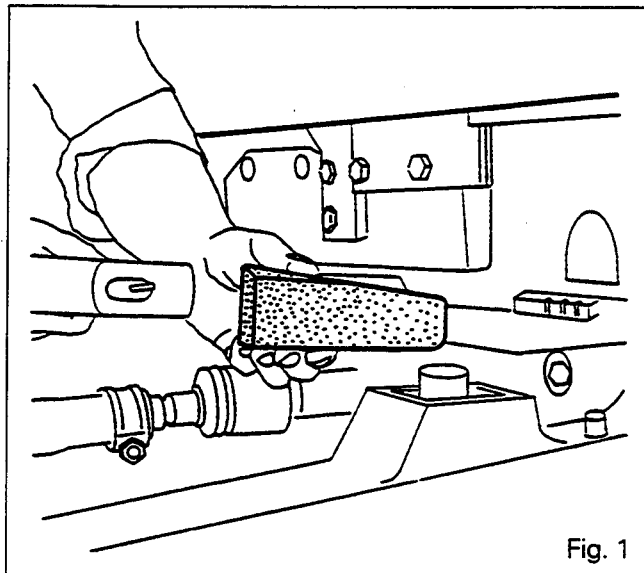

Fig. 1

13. Disconnect:
  - the wire from the radar (Datatronic),
  - the harness on the solenoid valve or valves on the Speedshift or Dynashift unit (according to version),
  - the solenoid valves harness on the right-hand hydraulic cover (brake and clutch, PTO, differential lock, 4WD and Hare/Tortoise),
14. Remove the gear and reversing levers (if fitted) from the selector cover and remove the harnesses (earth, electrohydraulically controlled reverse shuttle solenoid valves (according to option), temperature probe (if fitted) and Hare/Tortoise).
15. Remove the main filter (15 micrometres).
16. Remove the engine clutch lubricating tube mounted on the lower covers of the centre housing and on the gearbox.



# Splitting the tractor - Gearbox / rear axle

- 17. Disconnect the creeper gear control (if fitted) and then remove the bolt (1) and pull the rod (2) towards the outside to release the finger from the fork (Fig. 2).
- 18. Place stands:
  - under the rear axle housing,
  - to the rear of the hitch hook,
  - to the rear of the gearbox.
- 19. Remove the bolts (1) from the right-hand and left-hand cab supports (Fig. 3). Raise the cab and fit wedges.
- 20. Loosen the bolts attaching the gearbox to the rear axle.
- 21. Separate the gearbox from the rear axle (Fig. 4).

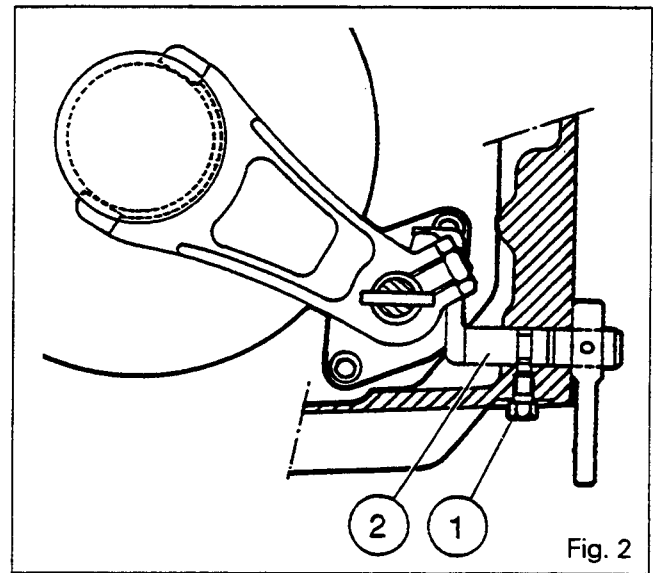

Fig. 2

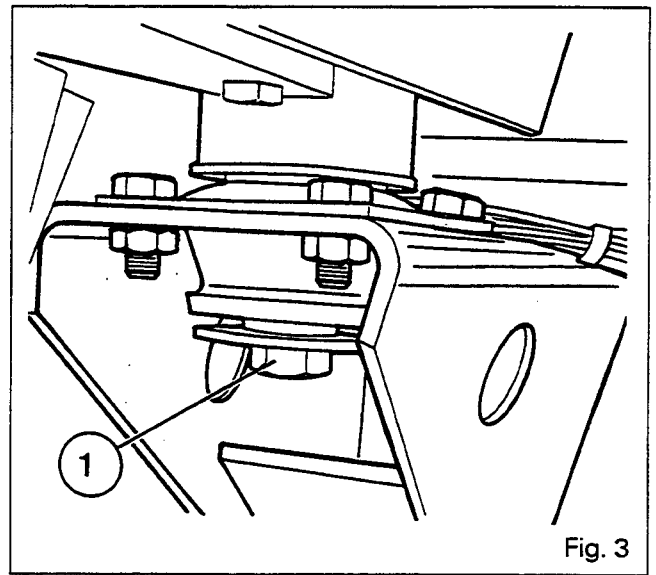

Fig. 3

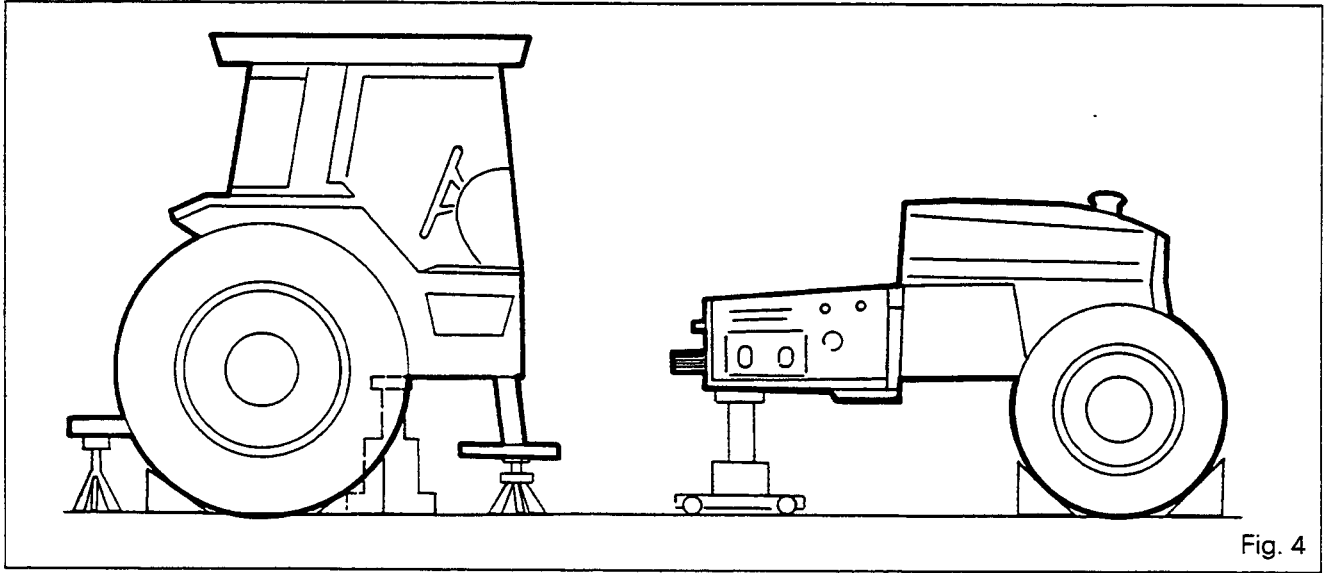

Fig. 4



2B01.4

# 6100 SERIES TRACTORS



## Splitting the tractor - Gearbox / rear axle

### B. Recoupling

22. Clean the mating faces on the gearbox and the rear axle housing.

#### On the rear axle

23. Position:

- the shaft (1) assembled with the sleeves (2) and (7) by means of double pins (5) and (6) (for gearbox without creeper gears) on the drive gear (3) (Fig. 5a),
- the shaft (1) assembled with the sleeve (2) by means of the double pin (5) (for gearbox with creeper gears) on the drive gear (3) (Fig. 5b).

**Note: Groove A in the sleeve (2) must be directed towards the differential ring gear (4) (Fig. 5).**

24. Check that the spring (1) is in place in the power take-off clutch and that the locating pins (2) are fitted (Fig. 6).

25. Check that the control finger «D» is in the forward direction (for gearbox with creeper gears) (Fig. 7).

26. Coat the mating face on the axle housing with Loctite 510 or an equivalent sealing compound.

27. Screw the two guide studs «G» on the housing (Fig. 6).

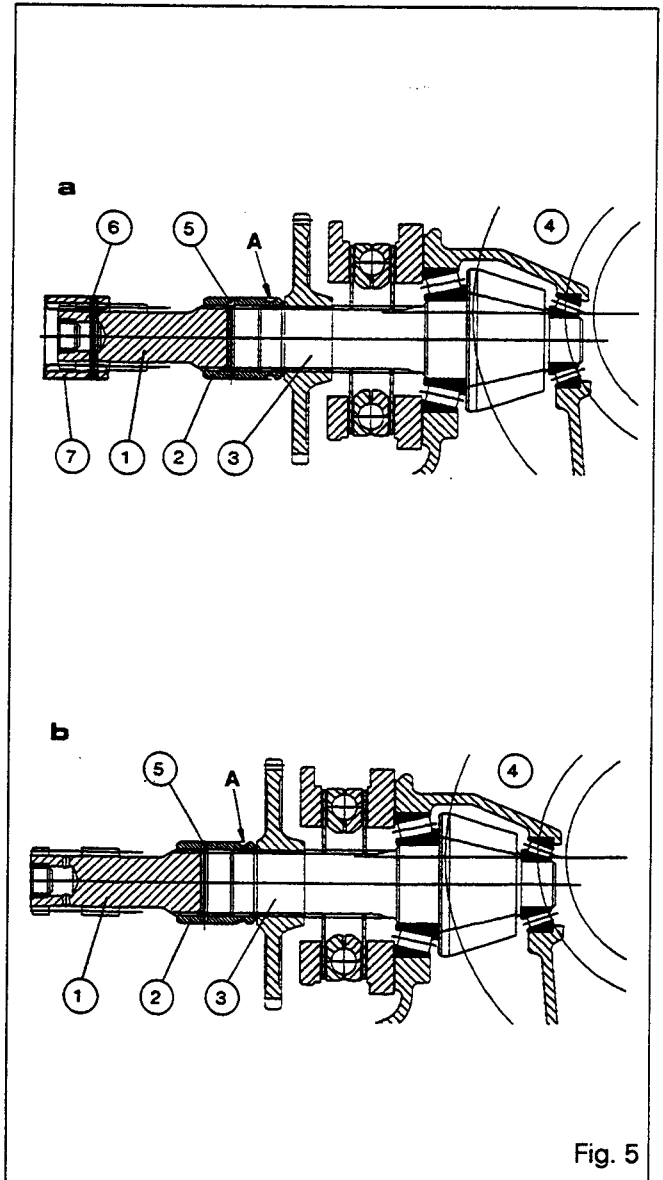

Fig. 5

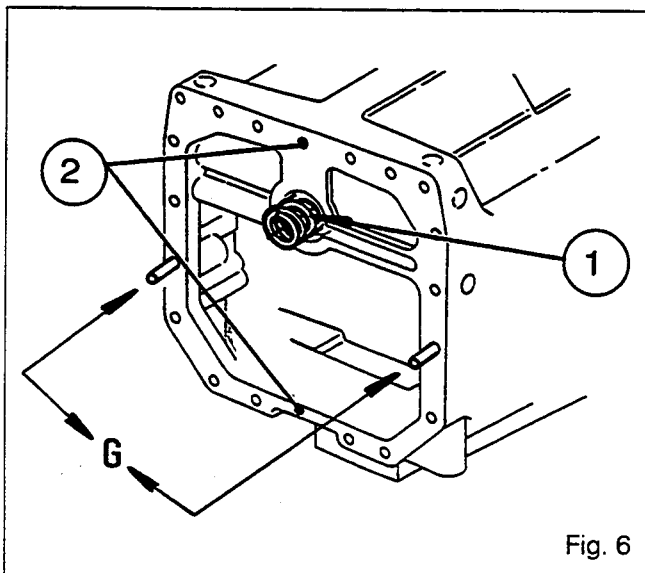

Fig. 6

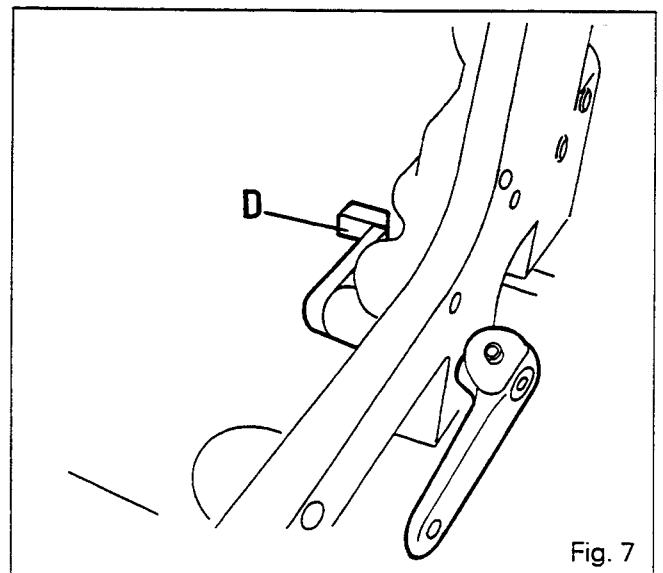

Fig. 7



## Splitting the tractor - Gearbox / rear axle

2B01.5

### On the gearbox

28. Replace the O-rings **(1)** on the Hare/Tortoise lines (Fig. 8).
29. Check that the PTO shaft is installed (see section 7E01). Recouple the tractor between the gearbox and the rear axle. Tighten the bolts to a torque of 155 to 195 Nm.
30. Lower the cab, fit the bolts on the shock absorbers **(1)** (Fig. 3) and tighten them to a torque of 200 to 270 Nm.
31. Remove the stand.
32. Turn and push the rod **(2)** in order to engage the finger in the fork. Tighten the bolt **(1)** after coating it with Loctite 241 (Fig. 2).
33. Check that the rod operates correctly. Reconnect and adjust the creeper gear control cable (see Section 5H01).
34. Reconnect the controls, harnesses, hoses, tubes and flexible couplings.
35. Top up the centre housing with oil.
36. Fit the 4WD drive shaft and the guard.
37. Reconnect the front differential lock control hoses (4WD).
38. Reconnect the batteries.
39. Reset the reverse shuttle electrohydraulic control system (if fitted). (See Section 5C02).
40. Bleed the clutch (see Section 4B01) or the control valve (Section 4A01), (according to version).
41. Check the hydraulic unions for leaks and the correct operation of the electric circuits.
42. Reinstall the protective guard, the sheet metal panels and the exhaust pipe.
43. Remove the wedges between the frame and the front axle. Release the handbrake.
44. Carry out road test on the controls for:
  - clutch,
  - electrohydraulically controlled reverse shuttle (if fitted),
  - creeper gears (if fitted).
45. Check for leaks on the mating face between the gearbox and the rear axle.

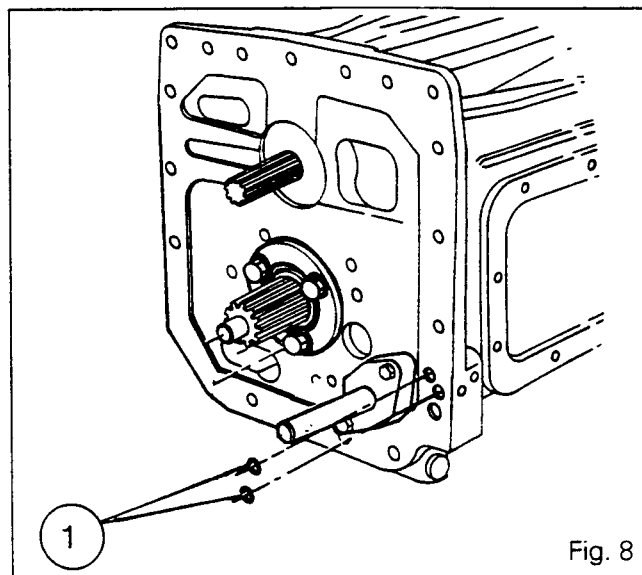
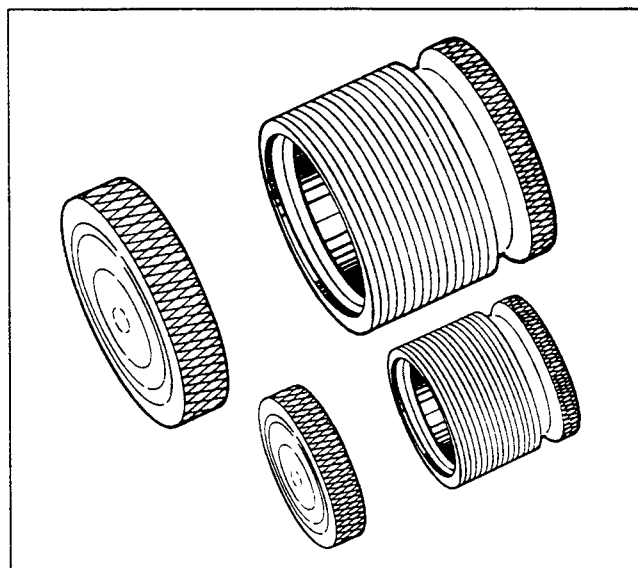

Fig. 8



### C. Service tool

**3376935M91 - Set of plugs for air conditioning couplings**







***Splitting the tractor - Front frame / engine***

2C01.1

*2 C01 Splitting the tractor between the front frame and the engine*

CONTENTS

<b>A. Uncoupling</b>	_____	<b>2</b>
<b>B. Recoupling</b>	_____	<b>3</b>
<b>C. Service tool</b>	_____	<b>3</b>



## Splitting the tractor - Front frame / engine

### A. Uncoupling

1. Disconnect the two 4WD front axle control hoses.
2. Remove the guard and the 4WD drive shaft.
3. Remove the sheet metal panels and the exhaust pipe.
4. Disconnect the earth cables only from the batteries.
5. Disconnect and mark the positions of hoses and flexible connections, as follows:
  - the two Orbitrol steering hoses,
  - the hose from the cooler on the 17-bar valve,
  - the harness for the flowmeter and its three hoses located to the left of the fuel filter,
  - the connectors for the main harness above the engine,
  - the positive cable on the starter,
  - the inlet sleeve between the turbocharger (if fitted) and the air filter,
  - the suction pipe between the air filter and the exhaust pipe (6180 and 6190).
6. Drain the cooling system. Disconnect the lower and upper hoses from the radiator.
7. Remove the upper attachment on the radiator.
8. Remove the air conditioning compressor and bracket assembly and tilt it forwards with its two hoses (according to option fitted).

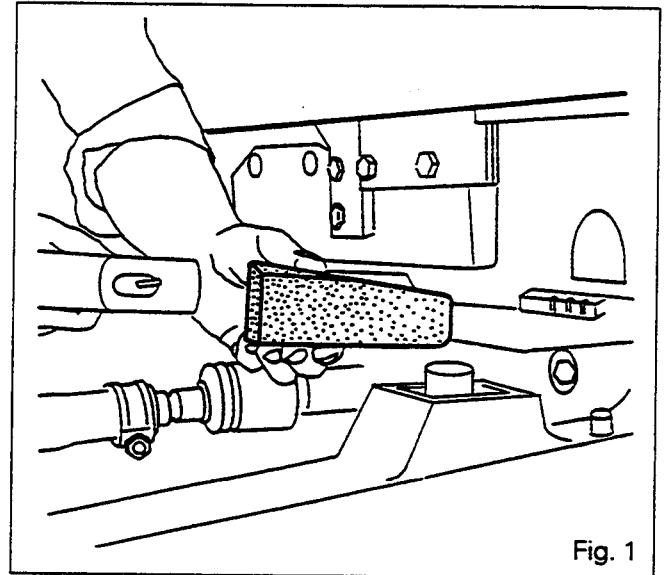

Fig. 1

9. Remove the front weights.
10. Immobilise the tractor. Apply the handbrake. Position wedges between the frame and the front axle (Fig. 1).
11. Loosen the bolts attaching the engine to the front frame.
12. Support the tractor under the frame using a trolley jack and separate the engine from the frame (Fig. 2).

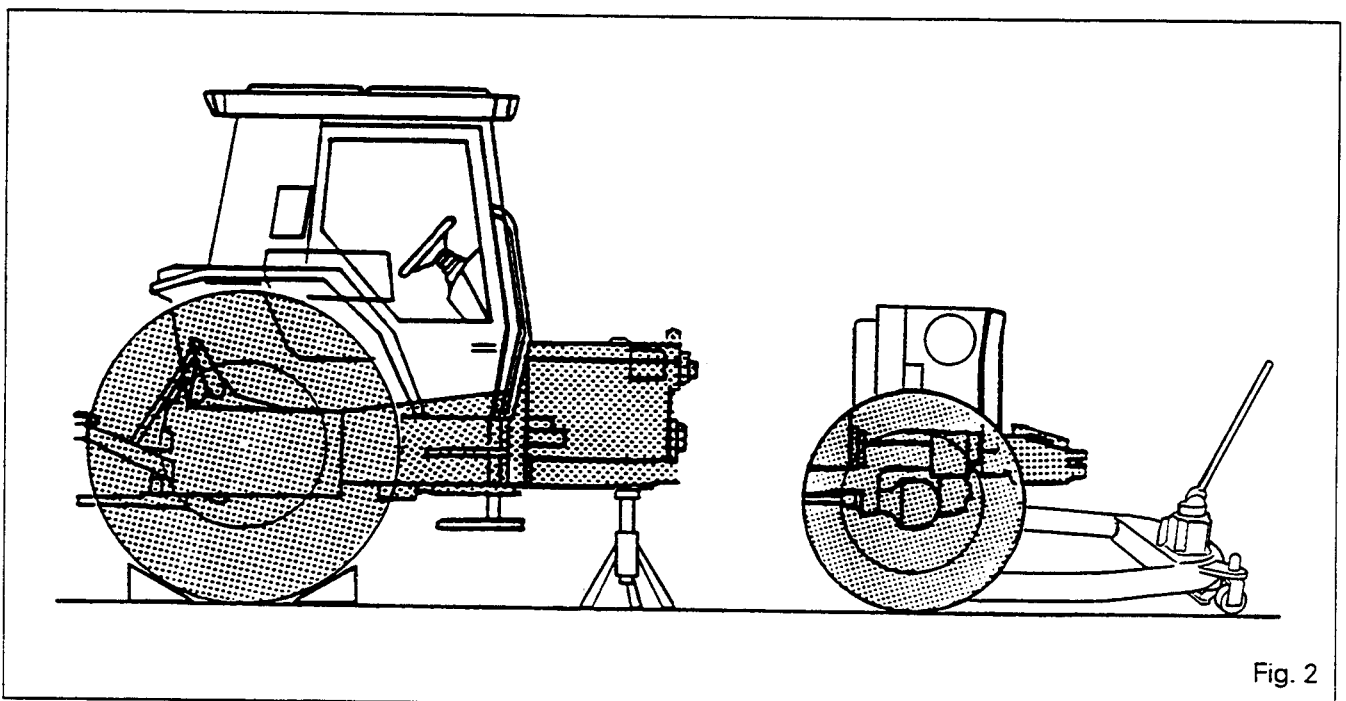

Fig. 2



## Splitting the tractor - Front frame / engine

2C01.3

### B. Recoupling

13. Screw two guide stud (locally manufactured) into diametrically opposite positions on the front frame.
14. Fit the frame to the engine.
15. Install the bolts and tighten to the specified torques:
  - 4-cylinder engines: see Fig. 3,
  - 6-cylinder engines: see Fig. 4.
16. Refit the air conditioning compressor and bracket assembly and the upper attachment on the radiator.
17. Reconnect the inlet sleeve, suction pipe, harnesses, hoses, flexible connections, and pipes.
18. Reinstall the front weights.
19. Top up the cooling system.
20. Reconnect the batteries.
21. If the tractor is equipped with a flowmeter, purge the injection pump supply system (4-cylinder engines).
22. Start the engine and check:
  - the hydraulic systems for any leaks,
  - the correct operation of the electrical systems.
23. Refit the sheet metal panels, the exhaust pipe, the drive shaft and the 4WD guard.
24. Reconnect the front axle control hoses.
25. Carry out road test

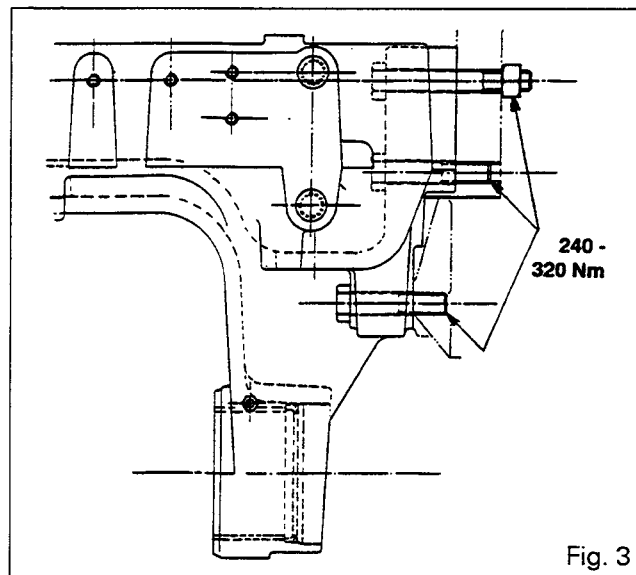

Fig. 3

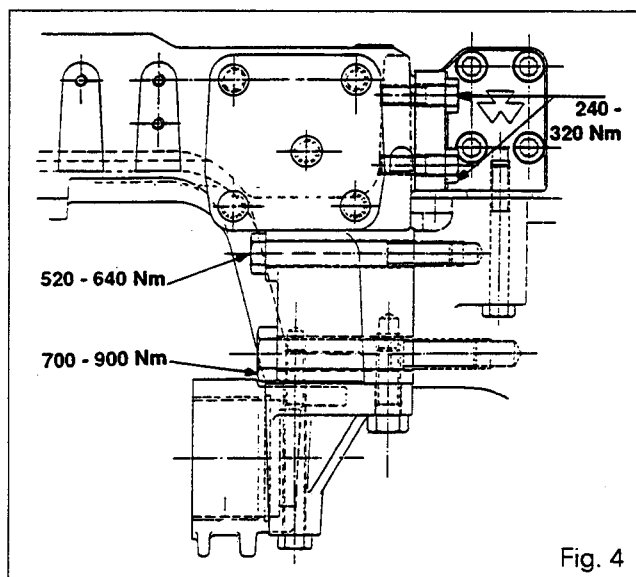
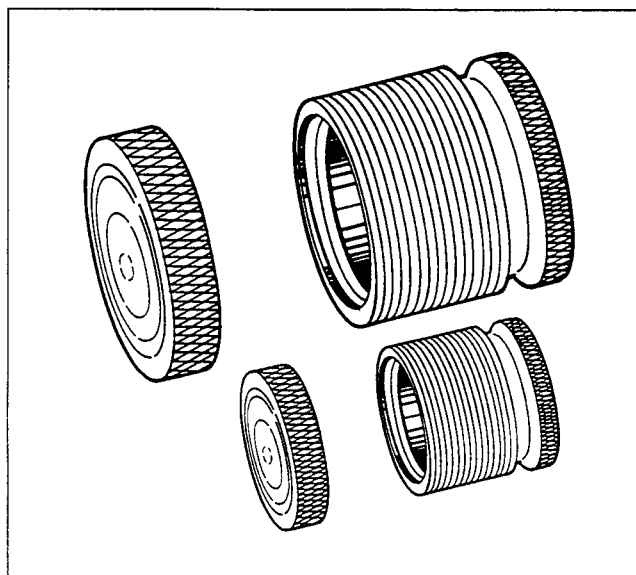

Fig. 4

### C. Service tool

**3376935M91 - Set of plugs for air conditioning couplings**







## **3 . ENGINE**

### **Contents**

**3 A01 GENERAL**

**3 B01 ENGINE FLYWHEEL**

**3 C01 SPACER - SPRING LOADED CLUTCH**

**3 C02 SPACER - PRESSURE LOADED CLUTCH**





**Engine - General**

*3 A01 General*

CONTENTS

<b>A. Introduction</b> _____	<b>2</b>
<b>B. Main specifications</b> _____	<b>3</b>
<b>C. Viscostatic fan</b> _____	<b>6</b>



3A01.2

---

## 6100 SERIES TRACTORS

---

### **Engine - General**



---

#### **A. Introduction**

---

The purpose of this section is to provide general information about the engines used for the 6100 range.

For all information on: technical data, adjustments and removal and fitting procedures, refer to one or other of the publication listed opposite :

1. Workshop manual for all types of Perkins engines manufactured for MF tractors, published by Massey Ferguson under reference 1856562 M1.
2. Workshop manual specifically for the 1000 series engines published by Massey Ferguson under the reference 1646906 M1.



## 6100 SERIES TRACTORS



3A01.3

**Engine - General****B. Main specifications**

	MF 6110	MF 6120	MF 6130
Engine type	4.41	4.41	1004-4TLR
Perkins list n°	LM 31282	LM 31283	AH 31279
No of cylinders	4	4	4
Bore (mm)	101	101	100
Stroke (mm)	127	127	127
Capacity (liter)	4,06	4,06	4
Compression ratio	16:1	16:1	16:1
Power at 2200 rpm (kW) (DIN 70020)	52	58,9	62,6
Max. torque (Nm)	269	286	325
at engine speed of (rpm)	1400	1400	1400
Idling speed (rpm)	750	750	750
Nominal speed (rpm)	2200	2200	2200
Max. speed no load (rpm)	2350	2350	2310
Fuel injection pump :			
Make and type	CAV DPA	CAV DPA	LUCAS DP200
Boost control	No	No	No
F.I.P.	3340 F 090 T	3340 F 080 T	8920 A 030 T
Perkins code	2643 C 307	2643 C 308	2644 C 104
Fuel pump code letters	AD	BD	DC
Governor spring position code	3	3	2
Rotation	Clockwise	Clockwise	Clockwise
No 1 cylinder output	W	W	W
Static timing angle (degrees)	-	-	13
Engine position	TDC	TDC	100° before No 1 TDC
Engine check angle (degrees)	280,5	280,5	No check angle
Pump check angle (degrees)	292	293	336,5
Static timing piston position (mm)	Not applicable	N/A	N/A
Injectors :			
Make	Lucas	Lucas	Lucas
Code	HL	HU	JK
Holder	2645 A 302	2645 A 302	2645 A 302
Nozzle	2645 K 602	2645 A 604	2645 A 613
Set and reset pressure (atmospheres)	230	220	220
Aspiration system	Naturally aspirated	Naturally aspirated	Turbo Garret
Mini boost pressure at 2200 rpm			
full load (mm Hg)	-	-	558
(Kpa)	-	-	-
(PSI)	-	-	-
Valve spring	Single	Single	Double
Valve inserts (In / Ex)	Exh	Exh	Yes / Yes
Valve angle (degrees - In / Ex)	45 / 45	45 / 45	30 / 45
Valve adjustment (mm - In / Ex)	0,20 / 0,45 <sup>±0.05</sup> hot or cold	0,20 / 0,45 <sup>±0.05</sup> hot or cold	0,20 / 0,45
Engine oil cooler	No	No	Yes
No of thermostats	1	1	1
Opening temperature	82° C	82° C	82°CC
Fan	-	-	Standard
Piston cooling jets	No	No	Yes
Oil filters	1	1	1
Fuel filters	1	1	1



## 6100 SERIES TRACTORS

### 3A01.4

## Engine - General

	MF 6140	MF 6150	MF 6160
Engine type	1104-4T2	1004-4THR2	1006-6HR4
Perkins list No	AH 31278	AH 31277	YA 31251
No of cylinders	4	4	6
Bore (mm)	100	100	100
Stroke (mm)	127	127	127
Capacity (liter)	4	4	6
Compression ratio	16:1	16:1	16.5:1
Power at 2200 rpm (kW) (DIN 70020)	66,2	69,9	73,5
Max. torque (Nm)	359	386	403
at engine speed of (rpm)	1400	1200	1200
Idling speed (rpm)	850	850	850
Nominal speed (rpm)	2200	2200	2200
Max. speed no load (rpm)	2310	2310	2310
Fuel injection pump :			
Make and type	Lucas DP200	Lucas DP200	CAV DPA
Boost control	Yes	Yes	No
F.I.P.	8920 A 022 T	8920 A 002 T	3369 F 170 T
Perkins code	2644 C 102	2644 C 101	2643 D 629 / LK
Fuel pump code letters	CC	BC	LK
Governor spring position code	1	2	5
Rotation	Clockwise	Clockwise	Clockwise
No 1 cylinder output	W	W	Y
Static timing angle (degrees)	13	-	22
Engine position	100° before No 1 TDC	100° before No 1 TDC	TDC
Engine check angle (degrees)	No checking angle	No checking angle	326,5
Pump check angle (degrees)	338,5 Locking angle	336,5 Locking angle	337,5
Static timing piston position (mm)	Not applicable	Not applicable	5,92
Injectors			
Make	Lucas	Lucas	CAV
Code	NR	JY	JU
Holder	2645 L 303	2645 A 302	LRB 67014
Nozzle	2645 L 614	2645 A 621	JB 6801 106
Set andf reset pressure (atmosphere)	230	250	220
Aspiration system	Turbo Garret	Turbo Wastegate	Naturally aspirated
Mini boost pressure at 2200 rpm			
full loac (mm Hg)	914	813	-
(Kpa)	21.86	108.34	-
(PSI)	17.67	15.72	-
Valve spring	Double	Double	Single
Valve inserts (In / Ex)	Yes / Yes	Yes / Yes	No
Valve angle (degrees - In / Ex)	30 / 45	30 / 45	45 / 45
Valve adjustment (mm - In / Ex)	0,20 / 0,45	0,20 / 0,45	0,20 / 0,45
Engine oil cooler	Yes	Yes	No
No of thermostats	1	1	2
Opening temperature	82° C	82° C	82° C
Fan	Standard	Viscostatic	Viscostatic
Piston cooling jets	Yes	Yes	No
Oil filters	1	1	1
Fuel filters	1	1	2

## 6100 SERIES TRACTORS



3A01.5

**Engine - General**

	MF 6170	MF 6180	MF 6190
Engine type	1006-6HR3	1006-6TLR2	1006-6T7
Perkins list No	YA 31250	YB 31265	YB 31245
No of cylinders	6	6	6
Bore (mm)	100	100	100
Stroke (mm)	127	127	127
Capacity (liter)	6	6	6
Compression ratio	16.5/1	16.0/1	16.0/1
Power at 2200 rpm (kW) (DIN 70020)	78,5	88,3	95,7
Max. torque (Nm)	440	490	474
at engine speed of (rpm)	1200	1400	1200
Idling speed (rpm)	850	850	850
Nominal speed (rpm)	2200	2200	2200
Max. speed no load (rpm)	2310	2310	2350
Fuel injection pump :			
Make and type	CAV DPA	Stanadyne	CAV DPA
Boost control	No	No	No
F.I.P.	3369 F 100	DB 2635 5110	3363 F 850
Perkins code	2643 D 804	2643 U 608	2643 D 615 / KK
Fuel pump code letters	UK	DL	KK
Governor spring position code	2	-	7
Rotation	Clockwise	Clockwise	Clockwise
No 1 cylinder output	Y	-	Y
Static timing angle (degrees)	17	12	18
Engine position	TDC	TDC	TDC
Engine check angle (degrees)	325,5	332	325
Pump check angle (degrees)	334	338	334
Static timing piston position (mm)	3,56	Not applicable	3,99
Injectors			
Make	CAV	Stanadyne	CAV
Code	JU	NV	JT
Holder	LRB 67014	2645 L 307	LRB 67032
Nozzle	JB 6801 106	2645 L 616	JB 6801 104
Set and reset pressure (atmosphere)	220	230	250
Aspiration system	Naturally aspirated	Turbo Garret	Turbo Schwitzer S 2B
Mini boost pressure at 2200 rpm			
full load (mm Hg)	-	508	450,04
(Kpa)	-	67,7	60
(PSI)	-	9,8	8,7
Valve spring	Single	Single	Single
Valve inserts (In / Ex)	No	Yes / Yes	No
Valve angle (degrees - In / Ex)	45 / 45	30 / 45	30 / 45
Valve adjustment (mm - In / Ex)	0,20 / 0,45	0,20 / 0,45	0,20 / 0,45
Engine oil cooler	No	Yes	Yes
No of thermostats	2	2	2
Opening temperature	82° C	82° C	82° C
Fan	Viscostatic	Viscostatic	Viscostatic
Piston cooling jets	No	Yes	Yes
Oil filters	1	1	1
Fuel filters	2	2	2



3A01.6

## 6100 SERIES TRACTORS

**Engine - General****C. Viscostatic fan****Description**

The 1000 series engines can be fitted with a cooling fan with an Eaton viscous coupling. This device increases power by 2 to 3hp.

The viscous coupling is made up of three main parts:

- The driving part powered by the engine and composed of shaft (1) integral with plate (2) with annular grooves.
- The driven part composed of hub (6) on which are mounted the fan and body (7) also with annular grooves.
- The regulating part composed of thermostatic spring (3) controlling valve (4).

The centre of the device has a reservoir (5) filled with a viscous silicone fluid.

**Method of operation**

When the temperature of the air going through the radiator reaches a predetermined value, thermostatic spring (3) acts on valve (4) which opens orifice a. The liquid is driven towards the annular grooves on hub (2) and body (7) by centrifugal force. The torque is transmitted by the internal friction of the very viscous fluid and its adhesion to the walls. The fan is thus driven, thereby increasing airflow and overall cooling efficiency.

The speed of the fan varies continually over the whole regulatory range depending on the temperature.

When the temperature of the air going through the radiator decreases, the spring closes the valve and stops the liquid from coming into contact with the friction area. The fluid gradually returns to reservoir (5) via pipe b, the fan is disengaged, leaving only a slight residual torque.

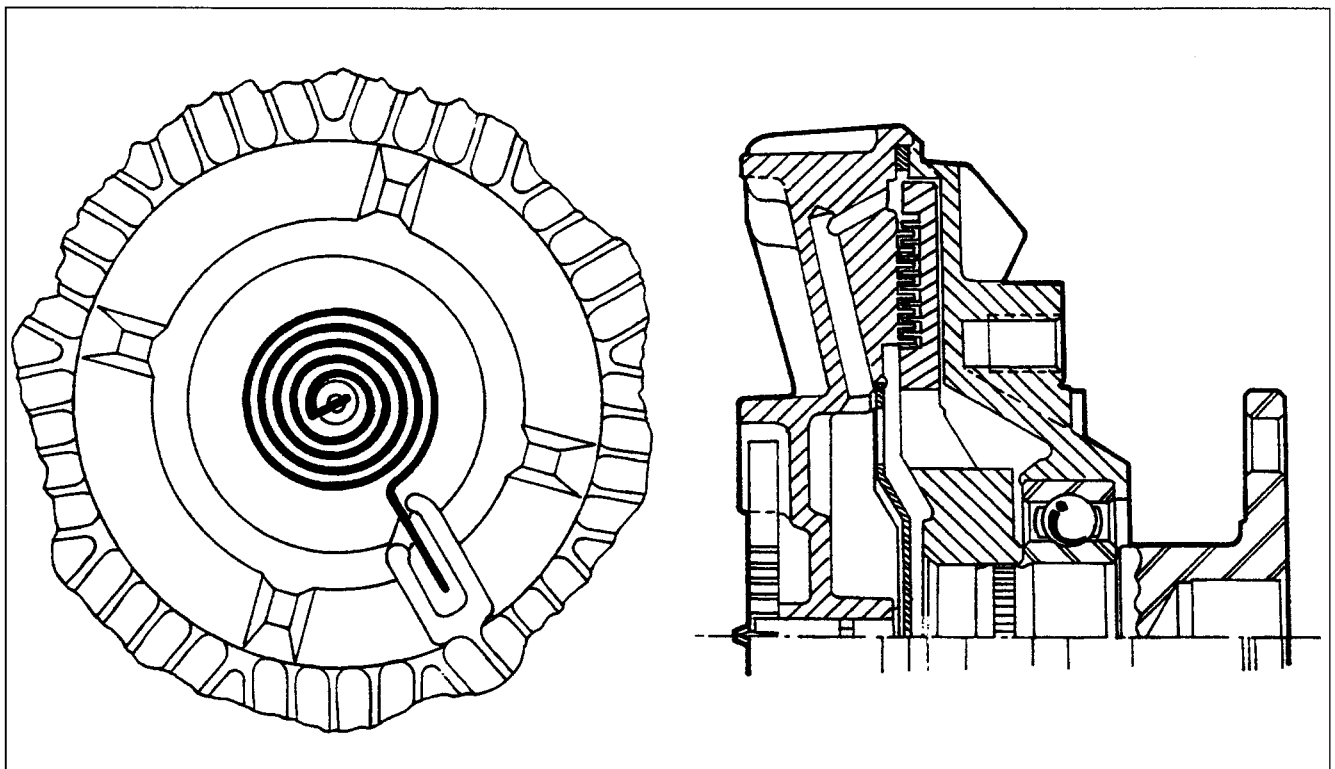
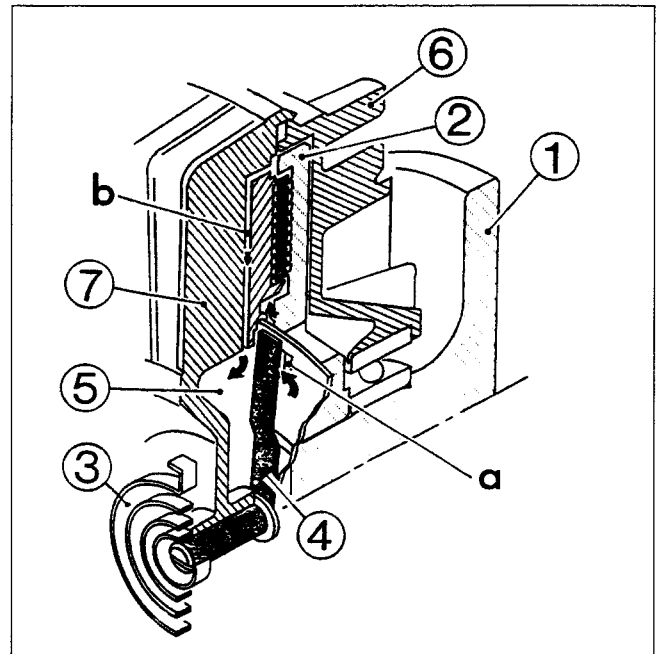



*3 B01 Engine flywheel*

CONTENTS

-	<b>General</b> _____	<b>2</b>
A.	<b>Removing and refitting the shock absorber</b> _____	<b>6</b>
B.	<b>Removing and refitting the engine flywheel</b> _____	<b>7</b>
C.	<b>Replacing the flywheel ring gear</b> _____	<b>7</b>
D.	<b>Service tool</b> _____	<b>7</b>



3B01.2

---

 6100 SERIES TRACTORS
 

---

**Engine - Engine flywheel**

---

**General (Figures 1 and 2)**

---

The shock absorber **(6)**, mounted on the engine flywheel and splined onto the input shaft, provides a smooth link between the engine and the clutch. This system is fitted on Dynashift and Speedshift type tractors with 4 and 6 cylinder engines.

To increase the reliability of the shock absorber (with spring-loaded clutch), its axial travel is limited by a spacer **(3)** that is fitted in the engine flywheel **(1)** and a bush **(9)**.

On tractors of types 6170 to 6180 from serial number F058049 and 6190 tractors (with pressure-loaded clutch) are equipped with a shock absorber **(6)** that is different from the one equipped with a spring-loaded clutch.

This shock absorber **(11)** is fitted in the crankshaft and supports the input shaft.

**Special points (Fig. 1)**

- Force-fitting of the washer **(10)** in the spacer **(3)**.
- When recoupling the tractor between the engine and the gearbox, check that the bush **(9)** is in place.
- **4-cyl. installation:** Long spacer **(3)** - Short bush **(9)**.
- **6-cyl. installation (6160 tractors):** Short spacer **(3)** - Long bush **(9)**.



Engine - Engine flywheel

3B01.3

Spring-loaded clutch

4-cylinder engine (6150)

6-cylinder engine (6160)

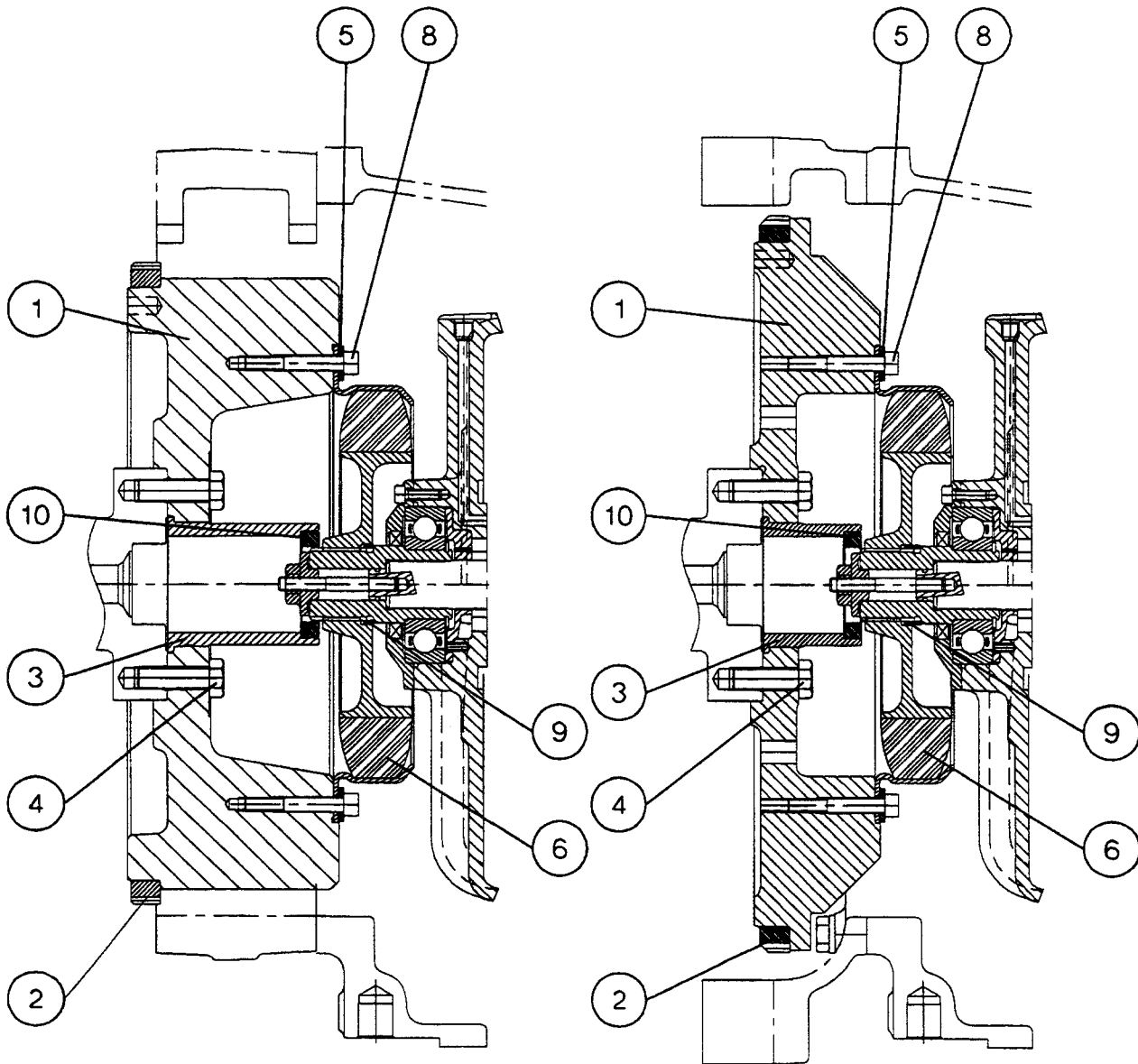

List of parts

- (1) Engine flywheel
- (2) Flywheel ring gear
- (3) Spacer
- (4) Bolt
- (5) Washer

- (6) Shock absorber
- (8) Bolt
- (9) Bush
- (10) Washer

Fig. 1



3B01.4

6100 SERIES TRACTORS



Engine - Engine flywheel

4-cylinder engine (6110 to 6140)  
Spring-loaded clutch

6-cylinder engine (6170 to 6180)  
Pressure-loaded clutch

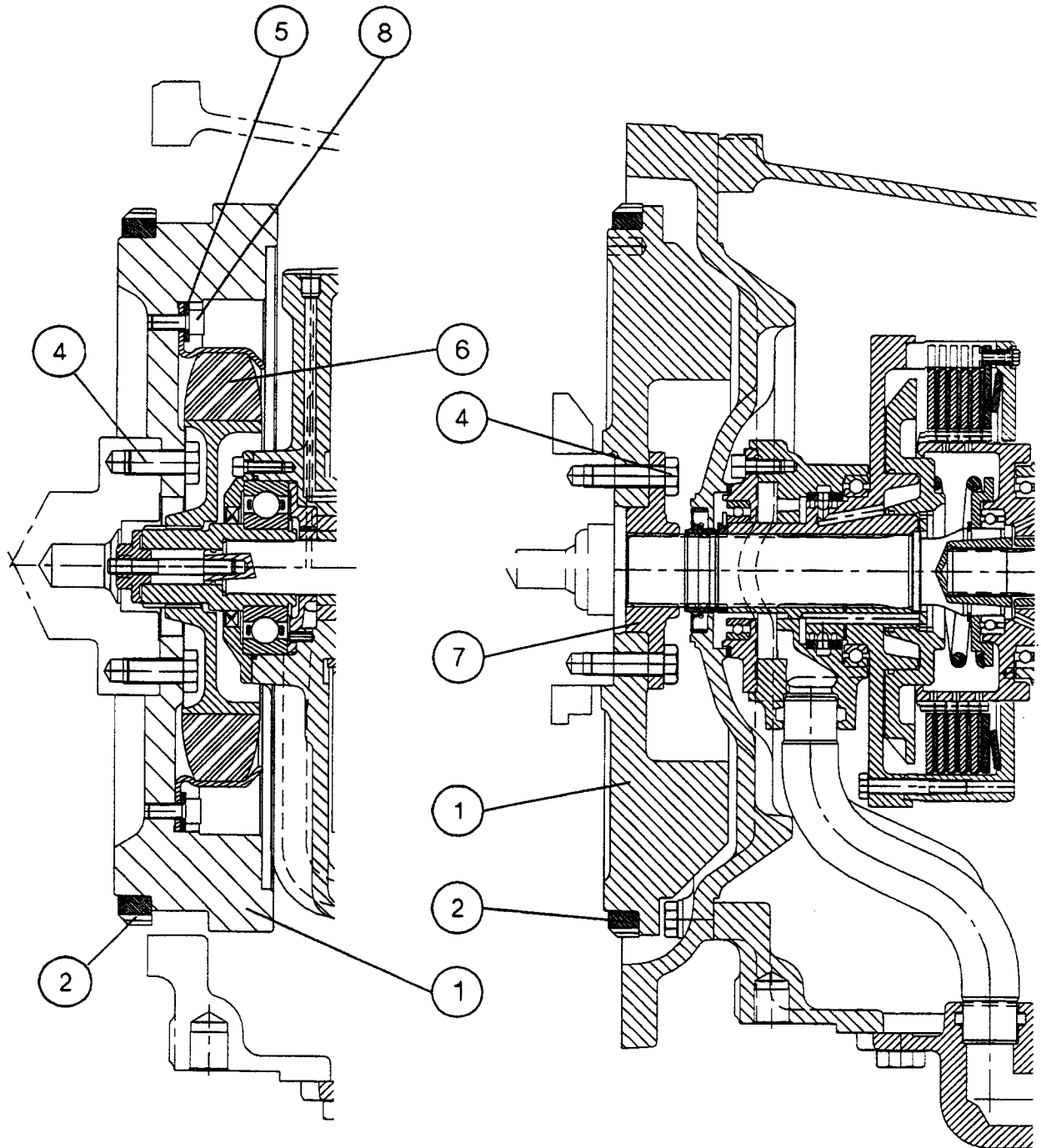

List of parts

- (1) Engine flywheel
- (2) Flywheel ring gear
- (4) Bolt
- (5) Washer

- (6) Shock absorber
- (7) Hub
- (8) Bolt

Fig. 2





# Engine - Engine flywheel

**6-cylinder engine  
Pressure-loaded clutch  
6170 to 6180, from serial number F058049, and 6190**

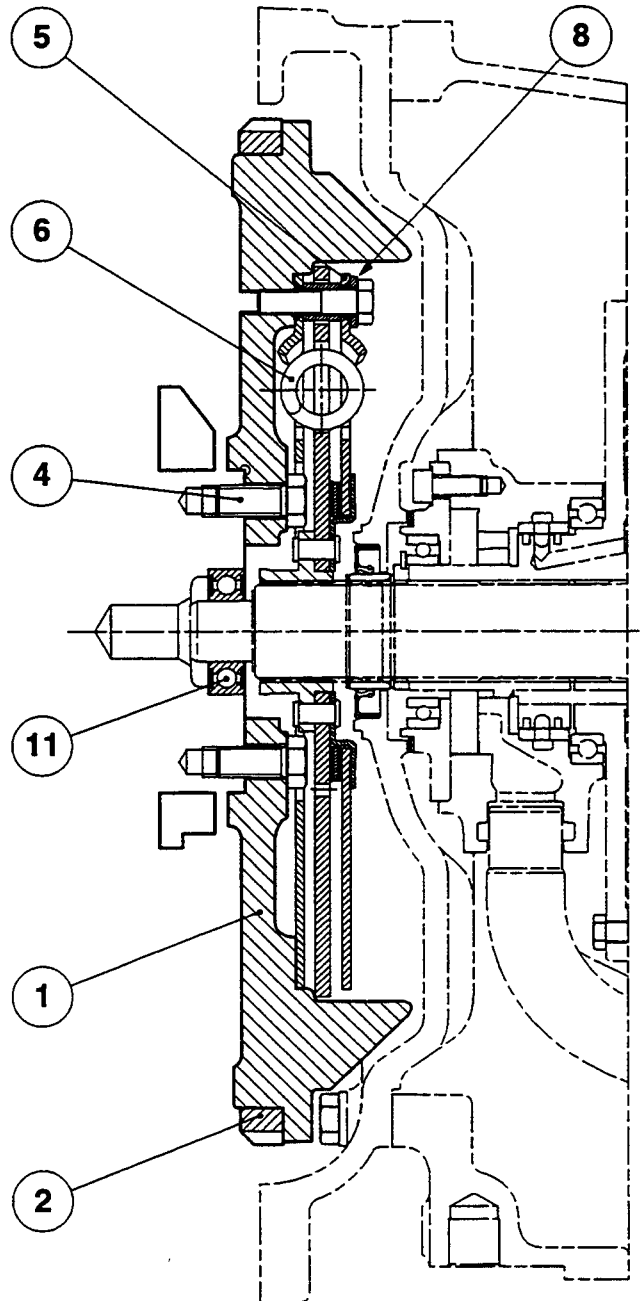

**List of parts**

- (1)** Engine flywheel
- (2)** Flywheel ring gear
- (4)** Bolt
- (5)** Washer

- (6)** Shock absorber
- (8)** Bolt
- (11)** Ball bearing

Fig. 3



3B01.6

## 6100 SERIES TRACTORS

**Engine - Engine flywheel****A . Removing and refitting the shock absorber (Fig. 3)**

**Note:** Tractors of types 6170 to 6180 from serial number F058049 onwards and 6190 tractors (with pressure-loaded clutch) are fitted with an LUK shock absorber (see description headed "General").

**Removal**

1. Uncouple the tractor between the engine and the gearbox (see Section 2A01).
2. Remove the bolts (8) and washers (5).
3. Remove the shock absorber. If necessary, use a suitable tool to extract the bearing (11) (Fig. 4).

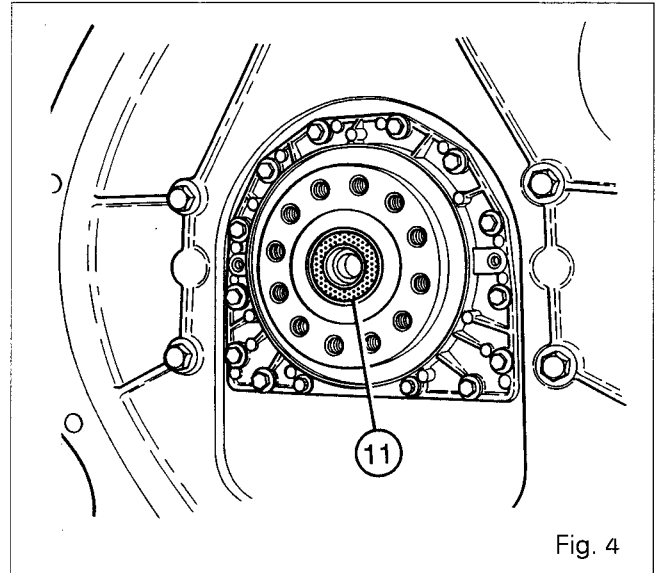

Fig. 4

**Refitting**

4. Lightly coat the splines on the shock absorber (6) with grease of type GN + Molykote and refit it. Coat the washers and bolts with Loctite 270 and, then, fit them and tighten them to a torque of between 29 and 37 Nm.

**Note:** On tractors of types 6170 to 6180, according to the serial number, and 6190 tractors:  
If the bearing (11) (Fig. 4) is removed, it must be fitted using a suitable fixture pressing on the bearing's outer housing.

Centre the shock absorber (6) on the flywheel using service tool 3378112M1 (Fig. 5), with the longer section of the shock absorber facing the flywheel (see Fig. 3). Fit the washers (5) and bolts (8) after coating them with Loctite 270, and tighten them to a torque of between 40 and 56 Nm.

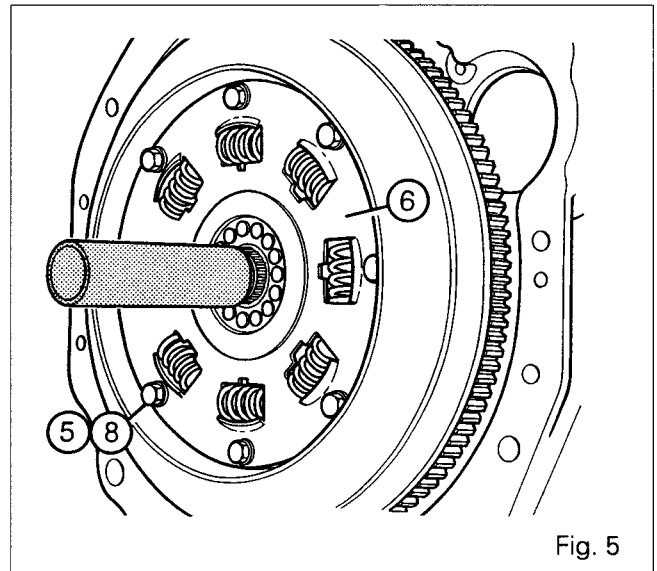

Fig. 5



## Engine - Engine flywheel

### B . Removing and refitting the engine flywheel (Figures 1 to 3)

#### Removal

1. Split the tractor between the engine and the gearbox (see Section 2A01).
2. Immobilise the engine flywheel.
3. Remove bolts (8) and washers (5). Remove the shock absorber (6). Remove bolts (4). Remove the engine flywheel with the bush (3) (if fitted).

#### Refitting

4. Screw the two guide studs into the flywheel attachment holes on the crankshaft.
5. Refit the engine flywheel with the bush (3) (according to the type). Take out the guide studs. Lightly coat the bolts with Loctite 270 and tighten them a torque of between 110 and 140 Nm.
6. Refit and centre the shock absorber (6). Fit the washers (5). Lightly coat the bolts (8) with Lotite 270 and tighten them a torque of between 29 and 37 Nm. On tractors 6170 to 6190, see Part A, operation 4.

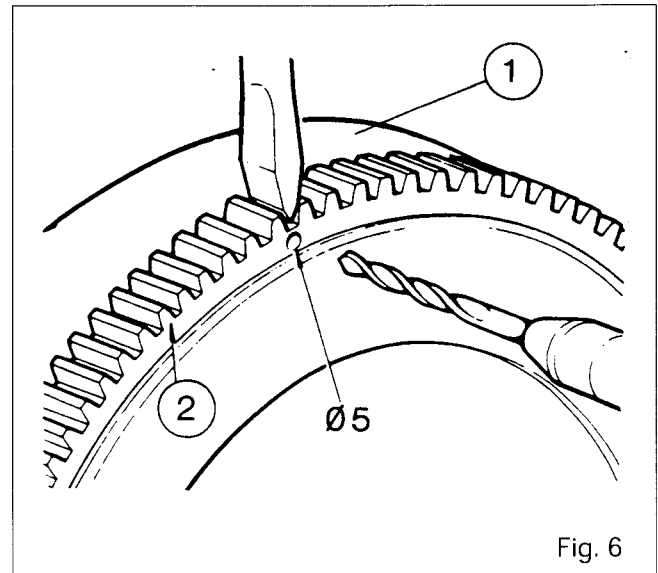

Fig. 6

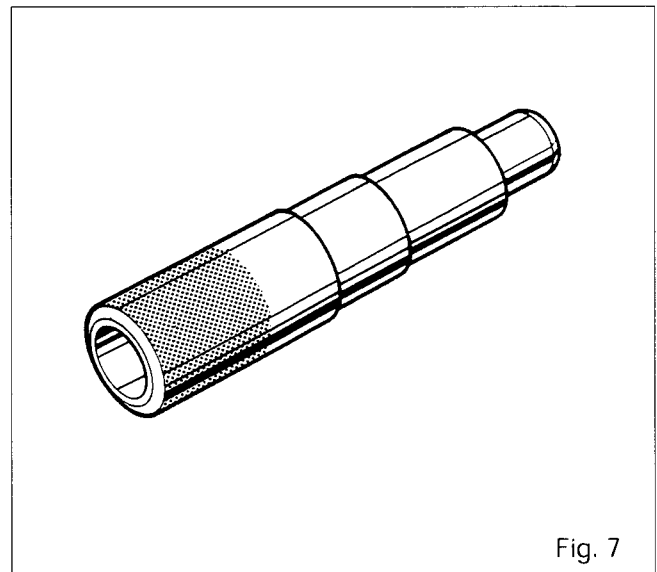

Fig. 7

### C . Replacing the flywheel ring gear

#### Disassembly

1. Remove the engine flywheel (see Part B).
2. Drill a hole (5 mm dia., 16 mm deep). Split the ring gear with a chisel, as shown in Fig. 6.  
**Note: Provide for protection against chips of metal when breaking the ring gear.**

#### Reassembly

3. Heat a new ring gear to 245°C, in a furnace only.
4. Fit the ring gear (2) on the engine flywheel (1) (with the tooth chamfer side facing the engine) and quickly push the ring gear fully home. Allow to cool slowly.

### D . Service tool

Tool available through MF network  
3378112M1 - Shock absorber centring tool (Fig. 7)





---

6100 SERIES TRACTORS

---



**Motor - Spacers**

3C01.1

*3 C01 Spacers - Spring-loaded clutch*

CONTENTS

A.	Spacer (4 cyl. engine) _____	2
B.	Spacer (6 cyl. engine) _____	3



3C01.2

## 6100 SERIES TRACTORS



### Motor - Spacers

#### A. Spacer (4 cyl. engine)

Tractors fitted with the 1004 engine and spring-loaded clutch are equipped with a spacer, 89 mm thick, mounted between the engine and the gearbox. The lower attachment is provided by studs of various lengths screwed onto the gearbox casing (Fig. 1).

#### Disassembly

1. Split the tractor between the engine and the gearbox (Section 2 A01)
2. Remove the spacer.
3. If necessary, extract the studs from the gearbox.

#### Refitting

4. Clean the mating faces on the spacer and the gearbox.
5. If the studs were removed, coat them with Loctite 270. Screw them in place and lock them, according to their lengths, in their positions as shown in Fig. 1.
6. Recouple the tractor between the engine and the gearbox (Section 2 A01).

#### Tightening torque

(1) to (15) = 100 to 130 Nm

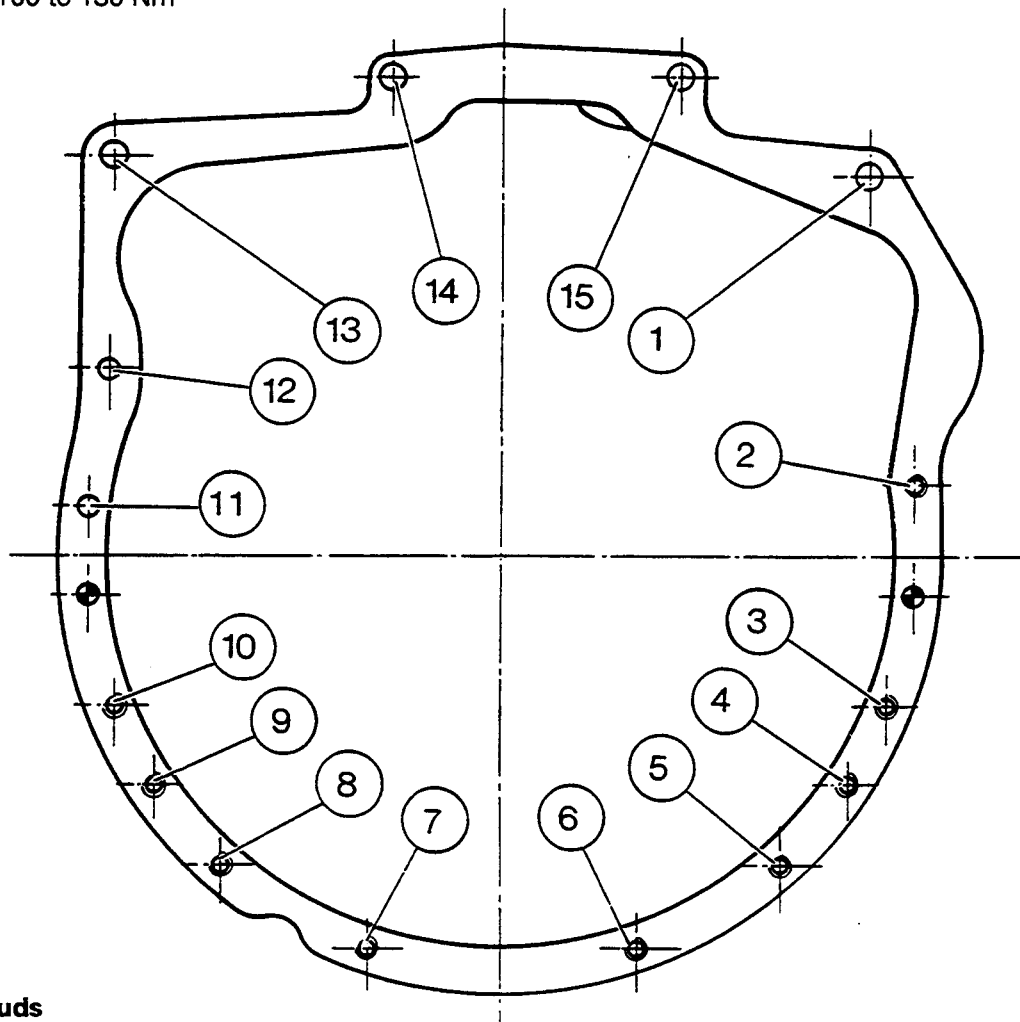

#### Length of studs

(3) = 145

(5) (8) = 155

(6) (7) = 130

Fig. 1



## Motor - Spacers

### B. Spacer (6 cyl. engine)

This spacer is fitted on tractors with the spring loaded clutch.

#### Disassembly

1. Remove the tool box.
2. Split the tractor between the engine and the gearbox (Section 2 A01).
3. Remove two spacer attaching bolts from the gearbox.
4. Screw two locally manufactured guide studs in their place.
5. Remove the 13 bolts and the spacer.
6. Remove the locating pins.

#### Refitting

7. Clean the mating faces on the spacer and gearbox.
8. Reinstall the locating pins.
9. Repeat operation 4 and carry out operation 5 in the reverse order.
10. Remove the guide studs. Fit and tighten the 15 bolts to a torque of 100 to 130 Nm.  
**Note: The countersunk head bolt /13\ must be correctly positioned (Fig. 2).**
11. Carry out operations 1 and 2 in the reverse order.

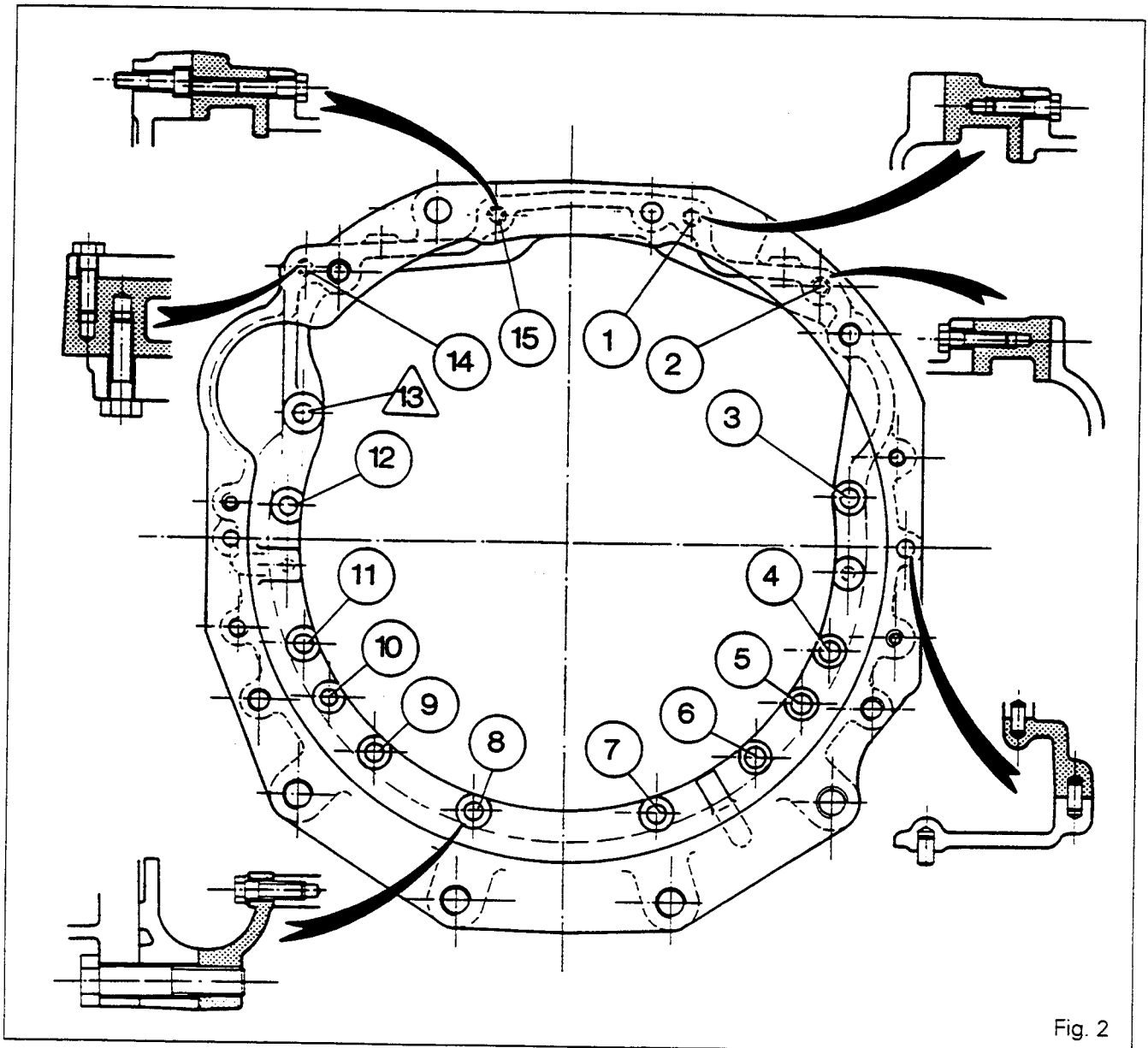

Fig. 2







**Engine - Spacer**

*3 C02 Spacer - Pressure-loaded clutch*

CONTENTS

-	<b>General</b> _____	2
A.	<b>Removing and refitting the spacer</b> _____	2
B.	<b>Removing and refitting the seal</b> _____	2
C.	<b>Service tool</b> _____	3



3C02.2

## 6100 SERIES TRACTORS

**Engine - Spacer****General**

6100 series tractors fitted with the pressure-loaded clutch are equipped with a spacer (16) mounted between the engine and the gearbox.

This spacer acts as a partition between the engine flywheel and the wet clutch. Tight sealing is provided by a lip seal.

The contact face of the spacer against the gearbox is coated with Loctite 510.

**Note: On 6170 - 6180 series tractors as from serial number F058049 and on 6190 series tractors: fitting of an input shaft (7) (Fig. 2) centred in the crankshaft.**

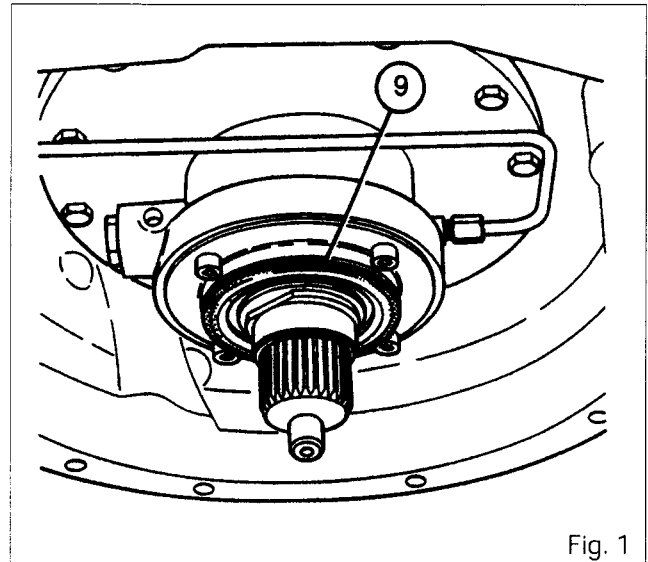

Fig. 1

**A. Removing and refitting the spacer**

**Note: When the spacer is replaced, it is necessary to repeat the shimming of the clutch assembly (Section 4 A01).**

**Disassembly**

1. Split the tractor between the engine and the gearbox (Section 2 A01).
2. Drain the oil from the gearbox.
3. Remove two attaching bolts from the spacer and screw two guide studs in their place, diametrically opposite on the gearbox.
4. Remove the remaining bolts. Place the protector 3378012M1 (C) on the input shaft. Detach and remove the spacer.

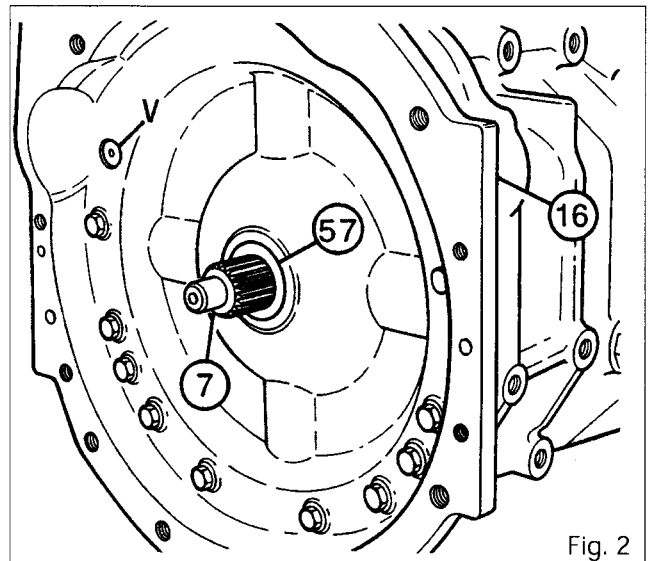

Fig. 2

**Reassembly**

5. Clean the mating faces on the spacer and gearbox.
6. Smear the mating face on the gearbox with Loctite 510 or equivalent.
7. Position the locating pins.
8. Screw two guide studs on the gearbox.
9. Position the protector on the input shaft.
10. Check that the shims (9) are installed (Fig. 1).
11. Reinstall the spacer. Remove the guide studs. Tighten the 15 bolts smeared with Loctite 270 to a torque of 100 to 130 Nm.

**Note : The countersunk head of bolt "V" must be correctly positioned (Fig. 2).**

12. Recouple the engine with the gearbox.

**B. Removing and refitting the seal (Fig. 2)****Removal**

13. Remove the spacer (see A).
14. Extract the seal (57).

**Refitting**

15. Clean the seating for the seal on the spacer.
16. Fit the seal with a press and a suitable fixture.
17. Fit the spacer (See A).



6100 SERIES TRACTORS



3C02.3

**Engine - Spacer**

**C . Service tool**

Tool supplied by the MF network  
3378012M1 - Oil seal protector

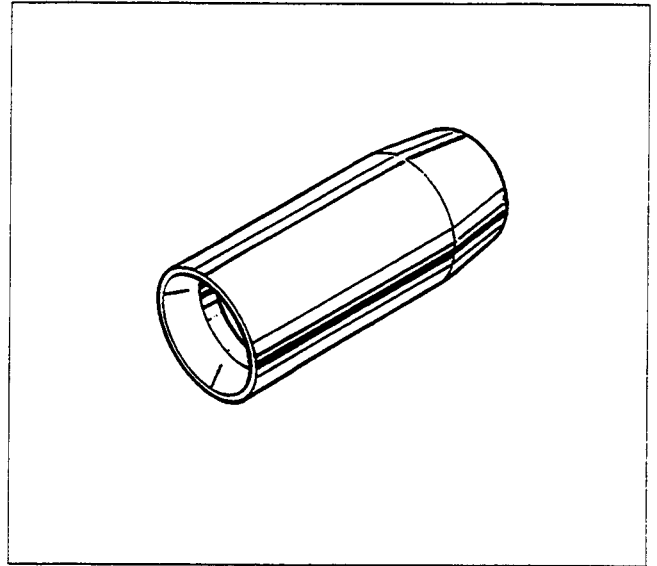





# **4 . CLUTCH**

## **Contents**

**4 A01 PRESSURE LOADED CLUTCH**

**4 B01 SPRING LOADED CLUTCH**



**Clutch** - Pressure-loaded

4A01.1

## 4 A01 Pressure-loaded clutch

## CONTENTS

-	<b>General</b> _____	<b>2</b>
A.	<b>Removing and refitting the oil seal and the O-ring</b> _____	<b>4</b>
B.	<b>Removing, refitting and shimming the clutch</b> _____	<b>4</b>
C.	<b>Dismantling and reassembling the clutch</b> _____	<b>5</b>
D.	<b>Removing and refitting the control valve</b> _____	<b>7</b>
E.	<b>Bleeding the clutch control</b> _____	<b>8</b>
F.	<b>Adjusting the clutch pedal</b> _____	<b>8</b>
G.	<b>Service tools</b> _____	<b>9</b>
H.	<b>Speedshift version</b> _____	<b>10</b>



4A01.2

## 6100 SERIES TRACTORS

**Clutch - Pressure-loaded****General****Description**

The new engine clutch system of the pressure-loaded type fitted on tractors in series 6170 to 6190 is of the oil bath multiple-disc type.

The system's construction and operating principle are identical to those of the system fitted on 8100 tractors.

The hydraulic clutch which transmits movement is similar to a PTO clutch but on a larger scale.

This clutch is controlled by a hydraulic valve fitted on the right-hand side of the gearbox which is, itself, operated by the clutch master cylinder.

To avoid problems with reliability, the oil used for this clutch must, imperatively, comply with standard MF M1143 or M1144.

Compared with the dry clutch, the wet clutch (oil bath) has the following advantages:

- enhanced reliability and longer service life,
- smaller load on pedal.

**Construction**

The wet clutch assembly is installed between the engine flywheel and the primary shaft of the Dynashift gearbox.

The input shaft (7) crosses through the spacer (16) which separates the engine flywheel from the transmission oil. The shaft (7) is constantly meshed with the fixed hub on the engine flywheel.

It rotates with the clutch housing (23) through splining. The clutch housing is equipped with friction plates (45) and the piston (46) moves inside it.

The drive hub (37) comprising discs (44) is engaged on the primary shaft (33).

The fixed housing (12) has two functions:

- it receives the 17-bar pressure,
- it forms the body for the lubricating and cooling pump (22 l/min, nominal pressure 0.4 bar).

This pump is supplied with oil from the centre housing via a 500-micrometre strainer, a pipe (17) located under the transmission and a second pipe (20).

The clutch assembly includes 5 discs and 5 plates.

The discs (44) are equipped with paper packing for optimum progressive application and quieter operation.

A washer (77) is fitted between the cover (39) and the latest plate (45).

**Operation****Clutch engagement**

When the clutch pedal is released, the hydraulic valve located on the right-hand side of the gearbox supplies a 17-bar pressure which moves the piston (46) which, in turn, presses the plates (45) against the discs (44) and the progressivity washer (77) in order to drive the primary shaft (33).

The valve controls the smooth action of clutch engagement and modulates the pressure applied on the piston. The washer (77) ensures the progressivity of the clutch.

**Clutch release**

When pressure is no longer applied, the piston (46) is pushed back by the spring (42) and the plates (45) are no longer in contact with the discs and the washer (77) is released.

The lubricating and cooling flowrate for the discs is cut off in the released position in order to avoid driving the discs by the «drag» effect. For the same reason, the discs have a bulged face to allow easier disengagement.

**List of parts**

(1) O-ring	(21) Spacer housing	(42) Spring	(63) O-ring
(2) Anti-extrusion rings	(22) Bolt	(43) Circlip	(64) Union
(3) Splined ring	(23) Clutch housing	(44) Discs	(65) Pipe
(4) Locking ring	(24) Dowel	(45) Plates	(66) Union
(5) Bolt	(25) Flange	(46) Piston	(67) Diagnostic connector
(6) Washer	(26) Bolt	(47) Clutch assembly	(68) Valve, 1.5 bar
(7) Input shaft	(27) Dust guard	(48) Seal	(69) O-ring
(8) Seal	(28) O-ring	(49) Seal	(70) Pipe
(9) Shim(s)	(29) O-ring	(50) Bearing	(71) O-ring
(10) Pipe	(30) Suction unit	(51) Bush	(72) Union
(11) Pump cover	(31) Bolt	(52) Oil seals	(73) Clutch supply pipe
(12) Pump body	(32) PTO shaft	(53) Lubricating pump	(74) Plug
(13) Dynashift cover	(33) Primary shaft	(54) Bolt	(75) Bolt
(14) O-ring	(34) Circlip	(55) Bearing	(76) Dynashift supply pipe
(15) O-rings	(35) Washer	(56) Circlip	pipe
(16) Spacer	(36) Bearing	(57) Oil seal	(77) Progressivity washer
(17) Pipe	(37) Drive hub	(58) Circlip	(78) Spacers
(18) Bolt	(38) Bolt	(59) Circlip	
(19) Flange	(39) Cover	(60) Bolt	
(20) Pipe	(40) Bearing	(61) Cover	
	(41) Support	(62) Strainer	





6100 SERIES TRACTORS

Clutch - Pressure-loaded



4A01.3

Overall view

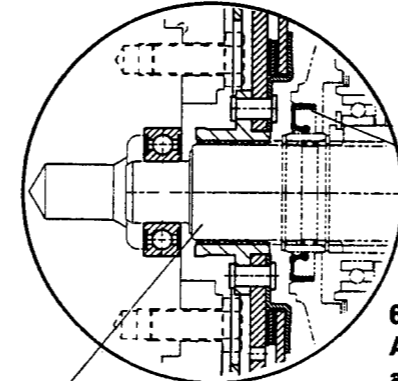
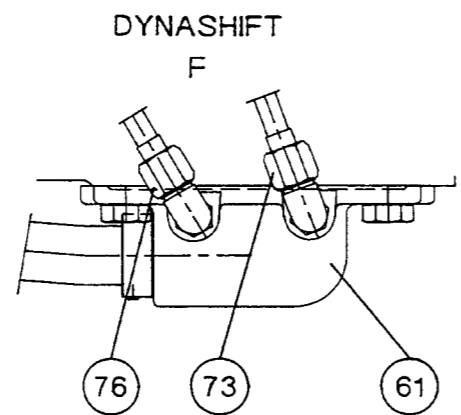
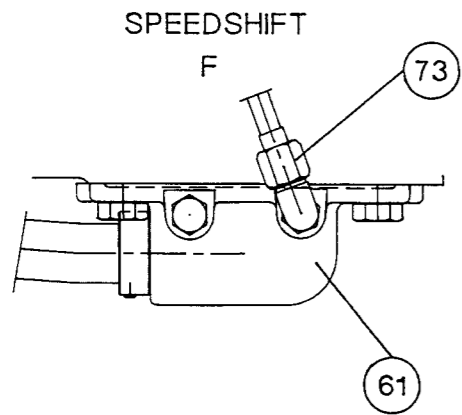
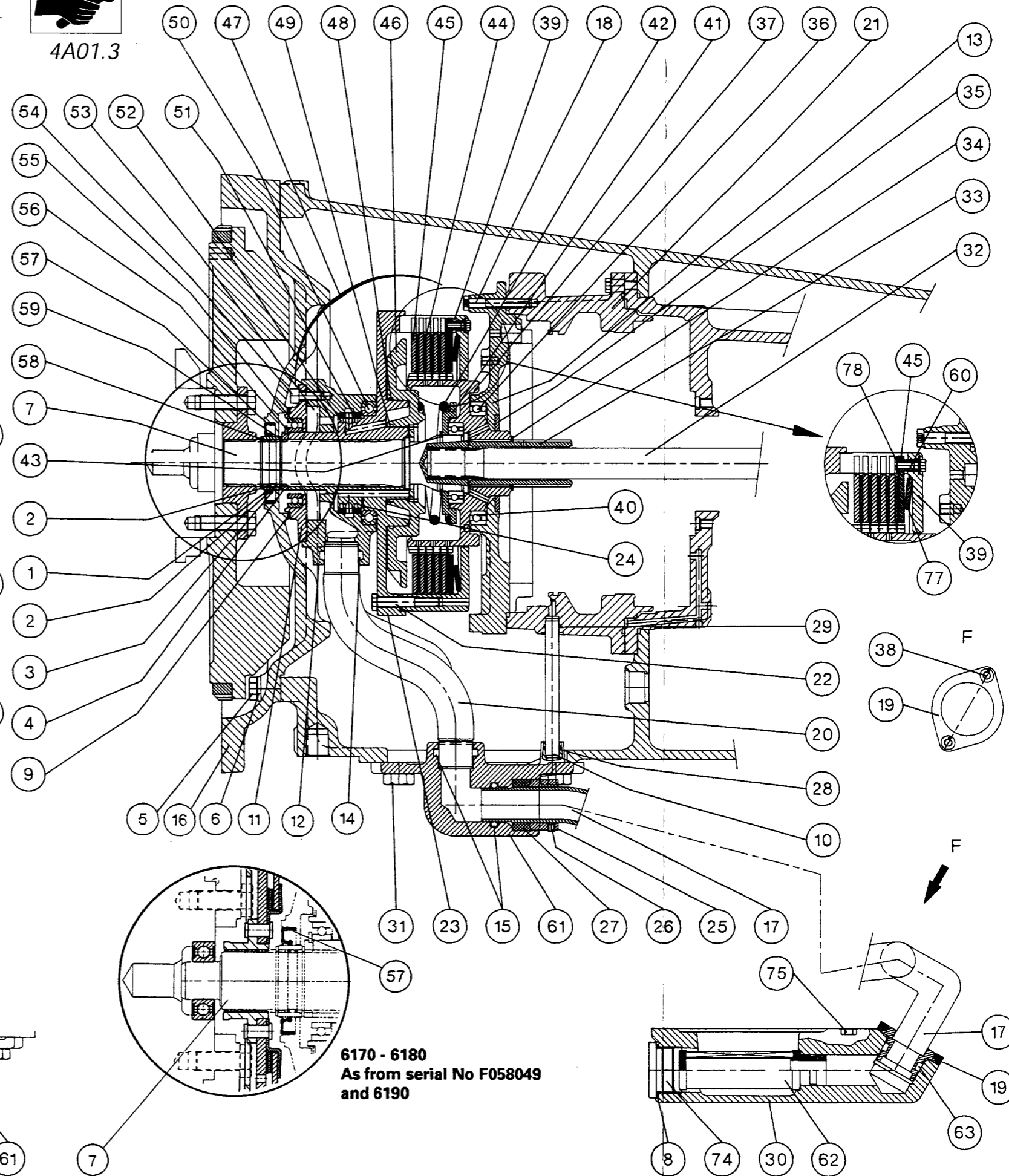
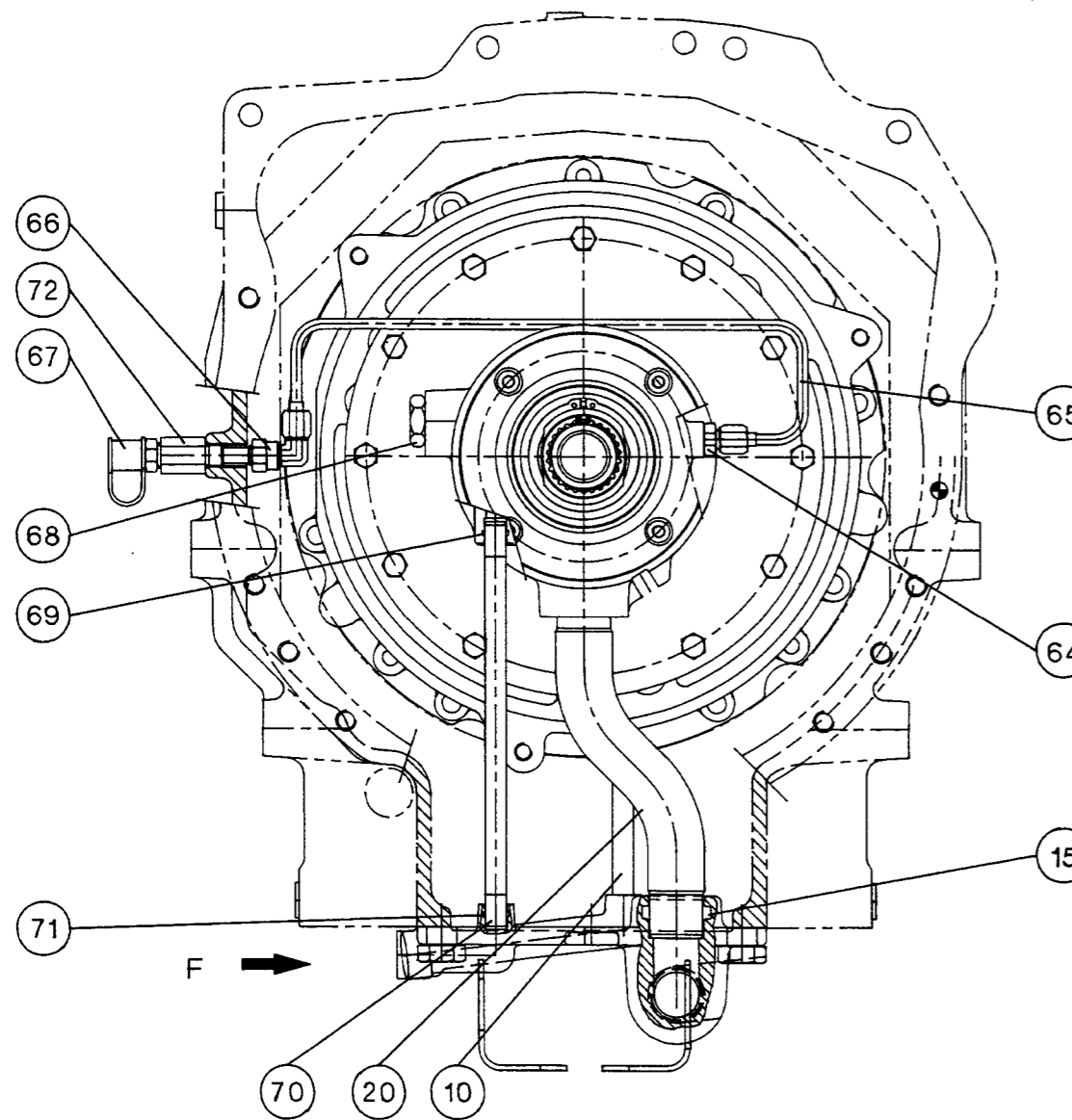

6170 - 6180  
As from serial No F058049  
and 6190

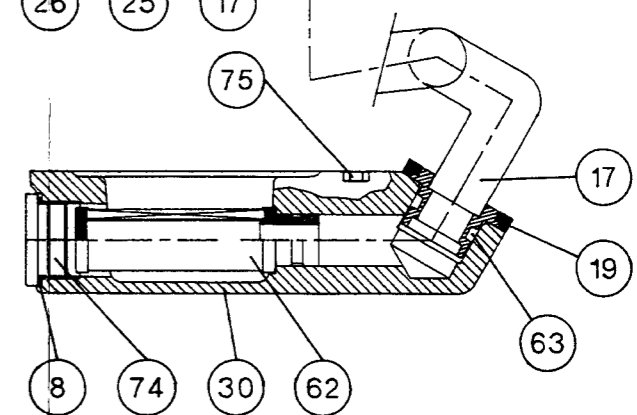



4A01.4

6100 SERIES TRACTORS

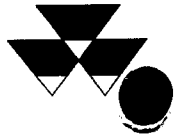

**Clutch** - Pressure-loaded

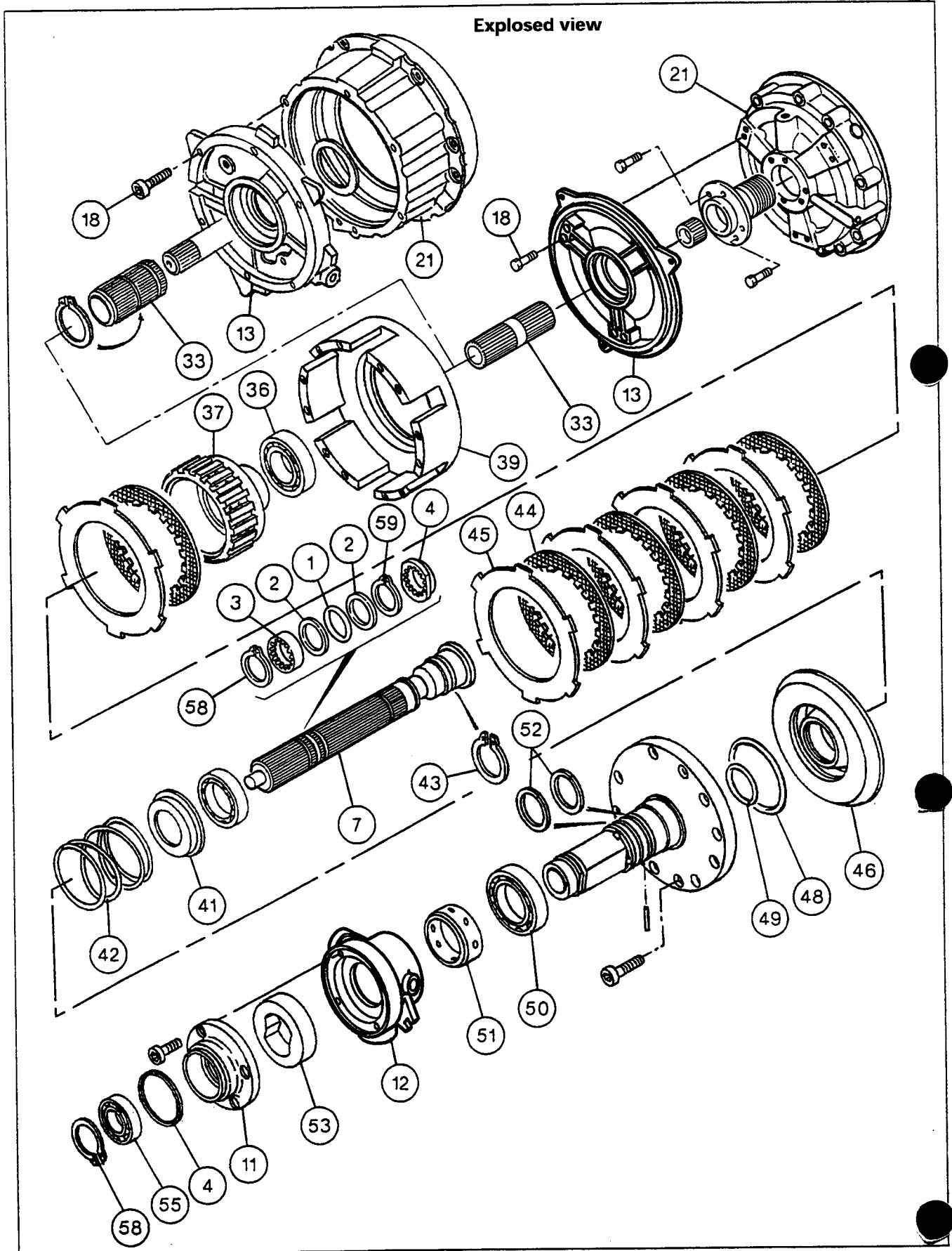



## Clutch - Pressure-loaded

### A. Removing and refitting oil seal (57) and O-ring (1)

#### Removal

1. Split the tractor between the engine and the gearbox (see section 2 A01).
2. Drain the oil from the gearbox.
3. Remove the spacer (16) (see Section 3 C02).
4. Take off the circlip (58) and remove the splined bush (3), bushes (2) and O-ring (1).
5. Extract the oil seal (57).

#### Refitting

6. Fit the oil seal (57) with a suitable fixture.
7. Place the O-ring (1) between bushes (2). Reinstall the splined bush (3). Replace the circlip (58) and position it correctly in the recess.
8. Check that the shims (9) are in place.
9. Replace the spacer (see Section 3 C02).
10. Top up the oil in the centre housing.
11. Recouple the tractor between the engine and the gearbox.

### B. Removing, refitting and shimming the clutch

#### Removal

12. Split the tractor between the engine and the gearbox (see Section 2 A01).
13. Drain the oil from the gearbox and rear axle.
14. Remove the spacer (see section 3 C02).
15. Remove the pipes (73) and (76), detach the cover (61), remove the flange (19) and the pipe (17).
16. Remove the clutch assembly (47) using a locally manufactured tool (Fig. 2).
17. Remove the PTO shaft (32).

#### Refitting

18. Replace O-rings (14) and (69).

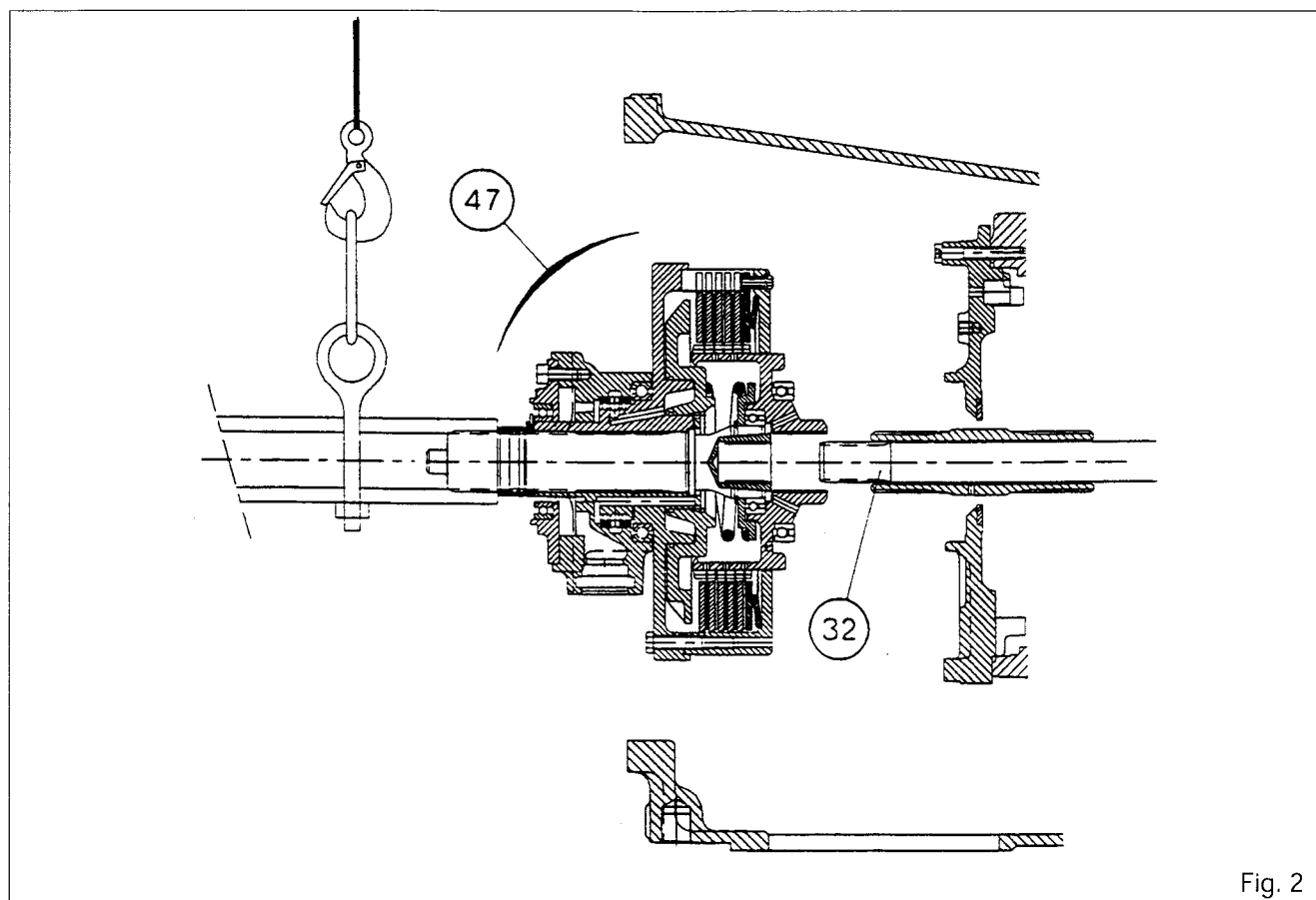

Fig. 2



4A01.6

## 6100 SERIES TRACTORS

**Clutch** - Pressure-loaded**Shimming the clutch assembly (Fig. 3)**

The aim of this operation is to obtain an end play of **J1 = 0.60 to 0.80** between the pump cover (11) and the spacer (16).

19. Remove the clutch assembly (47) from the primary shaft (33) with the tool used for procedure 16. Place a 2 mm thick shim (9) on the cover (11).
20. Grease the oil seal (57). Protect the splines on shaft (7) with protective device 3378012M1. Screw two studs in diametrically opposite positions on the spacer and refit the spacer (16) without applying Loctite. Tighten the bolts.
21. Position a dial gauge at the end of the shaft (7) and check the play, while moving the clutch assembly sideways.  
**Note: Make sure that the clutch assembly is correctly positioned in contact with the cover (13) before pulling on the shaft (Fig. 3).**
22. Remove the spacer (16) and, according to the play measured, select a thickness of shims (9) to obtain a play of **J1 between 0.6 and 0.8**.
23. Remove the clutch and refit the PTO shaft (32) (see section 7E01).
24. Refit the clutch assembly.
25. Apply miscible grease on the shims (9) selected in operation 22 and place them on the pump cover (11).
26. Replace O-rings (15), (71), (28) and (29).
27. Refit the unions (72) and (66) and the pipes (10), (20), (65) and (70).
28. Clean the mating faces on gearbox casing and on the cover (61). Smear the mating face on the gearbox casing with Loctite 510 or equivalent.
29. Replace the dust guards (27) and the O-ring (63).
30. Fit the pipe (17), the flange (19) and the cover (61). Tighten bolts (31) to between 200 and 260 Nm.
31. Tighten bolts (38) to between 41 and 53 Nm and bolts (26).
32. Reconnect the pipes on the unions (73) and (76).
33. Reinstall the spacer (see Section 3 C02).
34. Top up the oil in the centre housing.
35. Recouple the tractor between the engine and the gearbox.
36. Bleed the clutch control (see part E) and check the lubricating pressure.
37. Check the operation of the PTO clutch.
38. Carry out a road test.
39. Check for leaks on the flange (19) and cover (61).

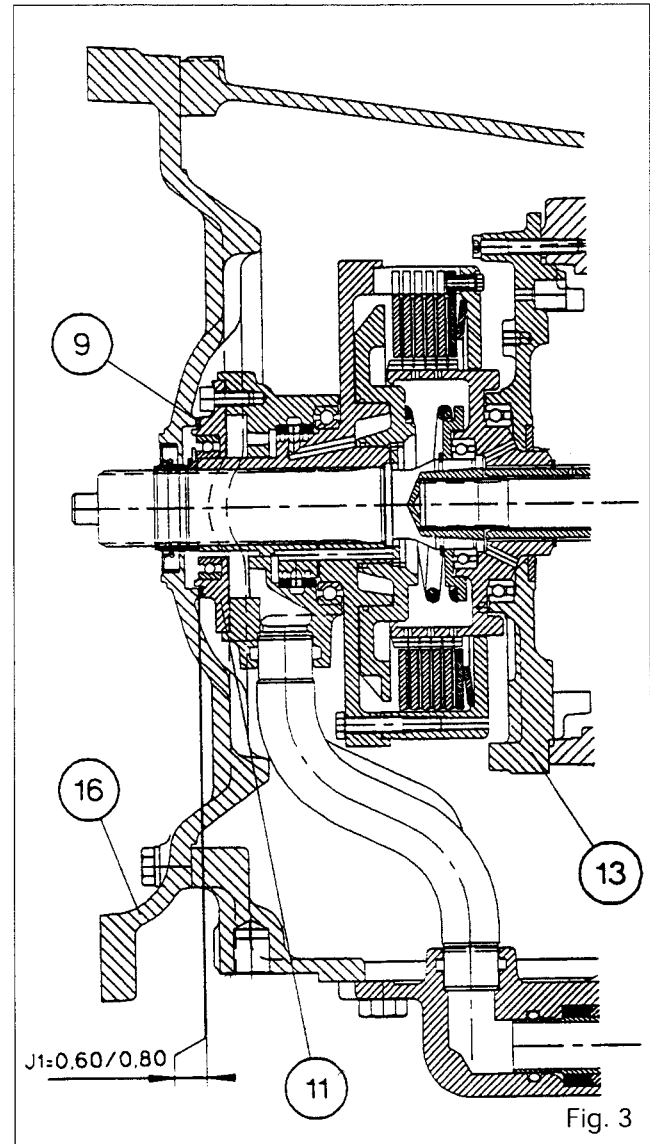

Fig. 3

**C. Dismantling and reassembling the clutch****Disassembly**

**Nota : An input shaft (7) with its end supported by a bearing fitted in the crankshaft has been introduced on tractors 6170 - 6180 as from serial number F058049 following the fitting of the LUK damper (see section engine flywheel 3B01) and on 6190 tractors.**

40. Place the clutch in the vertical position, with the cover (39) resting on a suitable support.
41. Take off circlip (58). Remove bush (3), bushes (2) and O-ring (1).
42. Take off circlip (56). Remove the pump body (11) and the bearing (55).



## Clutch - Pressure-loaded

43. Extract the lubricating pump (53) from the pump body (12). Separate the pump body from the clutch housing (23).
44. Remove the oil seal (52).
45. If necessary, extract bush (51) and remove the 1.5-bar valve (68).
46. Separate the clutch housing (23) from the cover (39). Remove the discs (44) and plates (45).
47. Remove the hub (37).
48. If necessary, extract the bearing (36).
49. Using a suitable fixture (see Part G), compress the spring (42). Remove the circlip (59) (Fig. 4). Remove the locking ring (4). Decompress the spring.
50. Separate the clutch housing (23) from the shaft (7). Remove the spring.
51. Remove the piston (46). If necessary, extract the bearing (50).
52. If necessary, remove the circlip (43), the support (41) and the bearing (40).

### Refitting

53. Check that the dowel (24) is in place.
54. If the bearing (50) was removed, refit it using a suitable fixture.
55. Install seals (48) and (49).
56. Use a plastic-tipped hammer to position the piston in the housing.
57. If the bearing (40) was removed, refit it with the sealing face towards the Dynashift using a suitable fixture. Fit the support (41) and the circlip (43).
58. Fit the spring (42) on the support (41).
59. Slide clutch housing (23) onto the input shaft (7).
60. Compress the spring with the tool used in procedure 49. Position bush (4), aligning two flats with the flats on the clutch housing (23). Replace the circlip (59) and position it correctly in its recess.
61. If the bearing (36) was removed, fit it using a suitable fixture, with the sealing face towards the Dynashift.
62. Position the hub with the bearing in the cover (39).
63. Soak the discs in a bath of transmission oil. Check that they are properly impregnated with oil.
64. On cover (39) fit the latest plate (45) with the progressivity washer (77), placed as Fig. 3, the spacers (78) and bolts (60) tightened to 2.2 - 3 Nm. Position the other plates (45) and discs (44) on the hub (37), aligning their recesses.
65. Place the clutch housing (23) on the cover (39). Tighten the bolts (22) to a torque of 25.5 to 34.5 Nm.

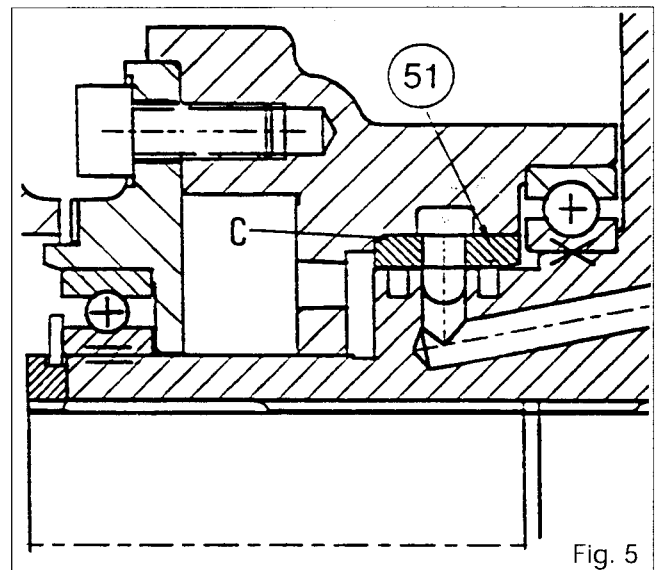
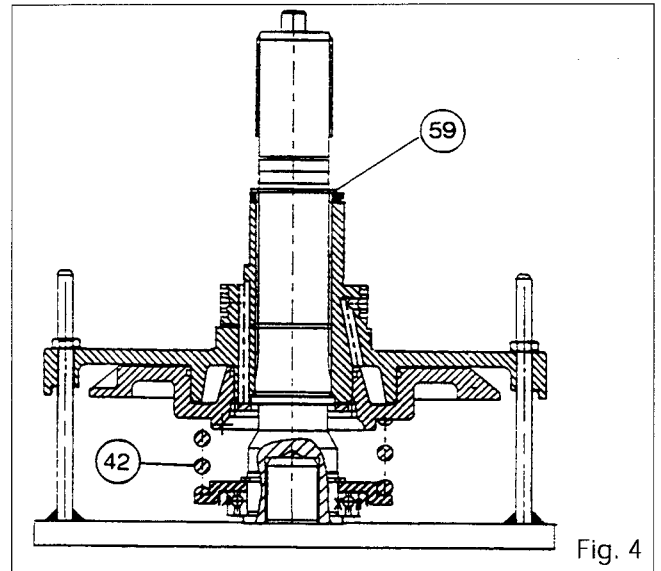

66. Check the rotation of the hub (37) by hand.
67. Check that the oil seals (52) turn correctly in their recesses. Fit the rings after smearing them with miscible grease, ensuring that they do not protrude beyond the circumference of the clutch housing.
68. If the 1.5-bar valve and bush (51) were removed, tighten the valve to a torque of 28 to 30 Nm and fit the bush using a suitable fixture, with chamfer «C» oriented as shown in Fig. 5.
69. Lubricate the bush. Assemble the pump body (12) on the clutch housing (23).
70. Oil the pump (53) and position it with its flats aligned with the flats on the clutch housing (23). By hand, check the angular displacement of the rotor on the flats on the clutch housing (23).



4A01.8

## 6100 SERIES TRACTORS

**Clutch** - Pressure-loaded

71. Refit the pump cover **(11)**. Fit the bearing **(55)**.  
Position the circlip **(56)**. Tighten the bolts **(54)** to a torque of 25 to 35 Nm.
72. Fit O-ring **(1)** and bushes **(2)**. Repeat procedure 7.

**D. Removing and refitting the control valve (Fig. 6)****Removal**

73. Remove the guards protecting the controls and the solenoid valves.
74. Disconnect pipes, the hose and the connectors for solenoid valves **EV1** and **EV2** (and mark their positions).
75. Remove the support **(6)** and the valve **(4)**.

**Refitting**

76. Fit the support and the valve. Tighten the bolts:  
- **(5)**: 25 to 35 Nm,  
- **(7)**: 50 to 70 Nm.
77. Reconnect the pipes, hose and connectors.
78. Bleed the clutch control valve (see Part E).
79. Check the valve's modulating pressure (see Section 9 L01).
80. Check for leaks on the mating surface and the unions. Check the operation of the Dynashift.
81. Reinstall the guards.

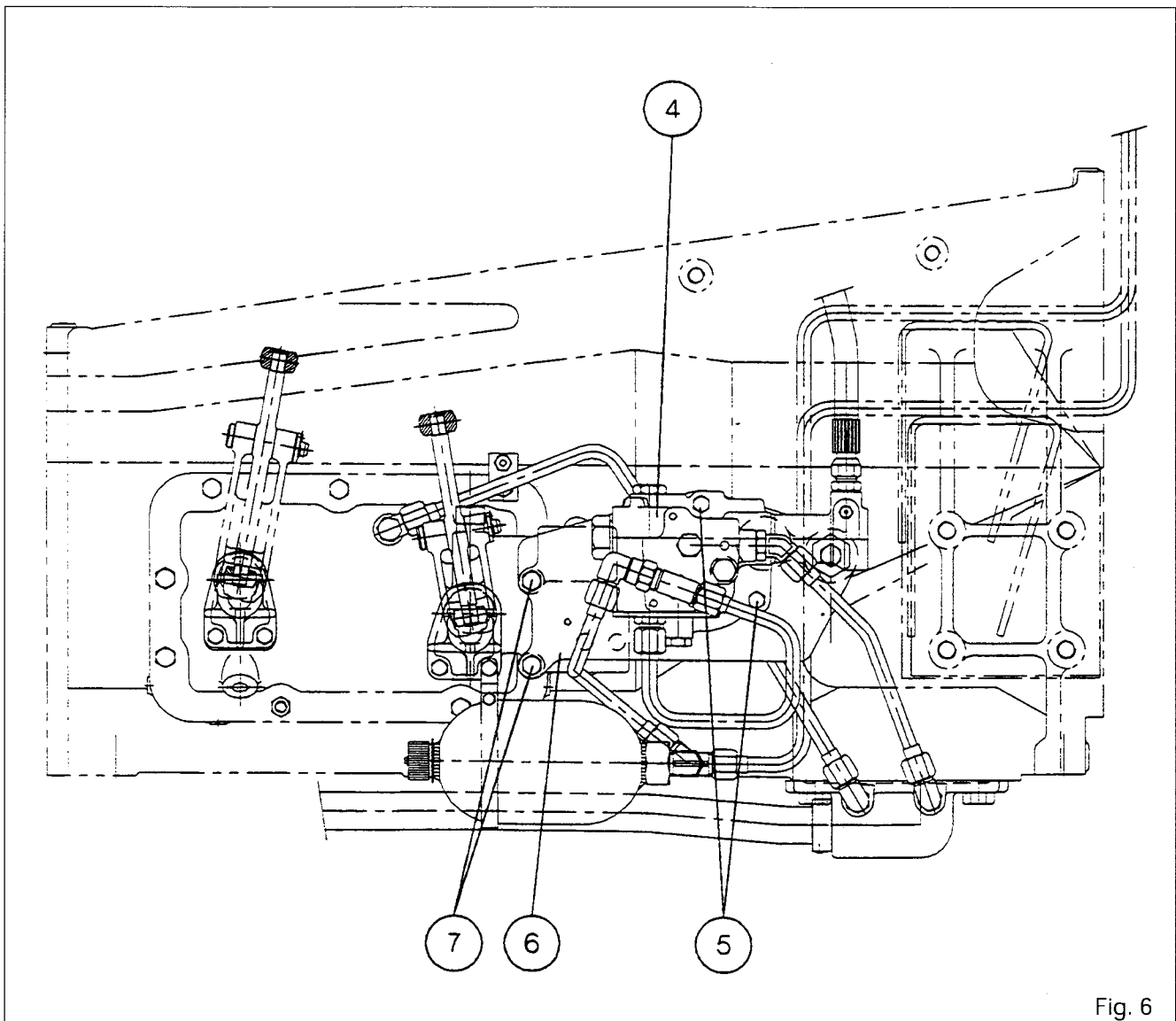

Fig. 6



## Clutch - Pressure-loaded

### E. Bleeding the clutch control (Fig. 7 and 8)

82. Run the engine at about 1200 r.p.m.
83. Using suitable protection, clamp the return hose(s) **(1)** according to the type of hydraulics system or the serial numbers, as follows :
  - Fig. 7A : up to No D086000 (std 6100)
  - Fig. 7B : as from No D086001 (std 6100)
  - Fig. 7C : tractors equipped with closed centre hydraulic system
84. Fit a pipe on the bleed screw **(2)** as shown in Fig. 8.
85. Loosen the bleed screw and slowly press the clutch pedal.
86. Check the adjustment of the clutch pedal (see Part F).
87. Carry out a road test.

#### Tractors equipped with closed centre hydraulic system (Fig. 7C)

- Use the same method and correctly identify the return hose **(1)** located to the front left-hand side of the gearbox. Block the return hose with a clamp fitted with suitable protection.

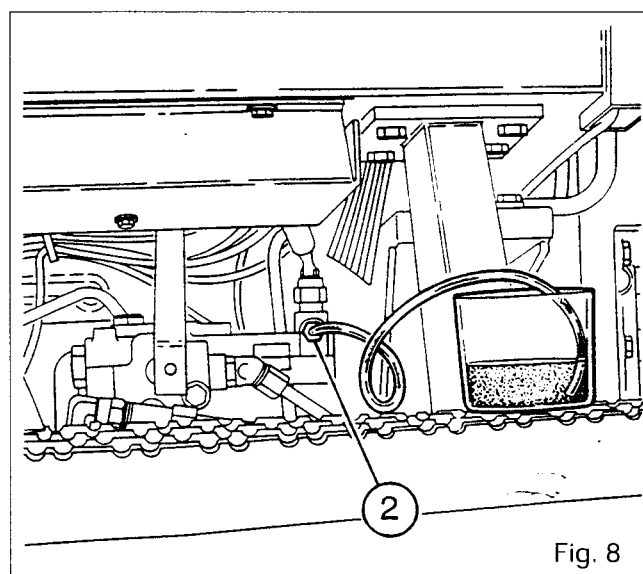
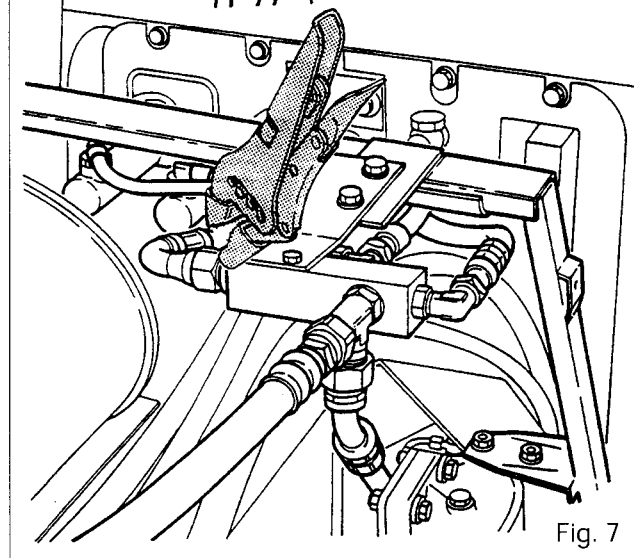
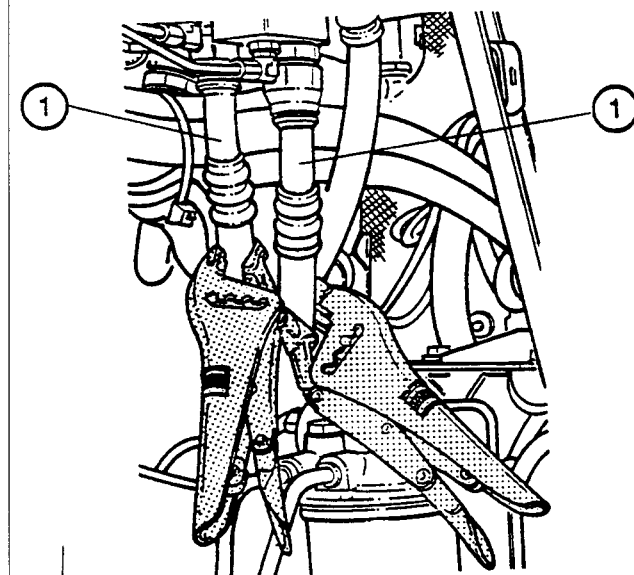
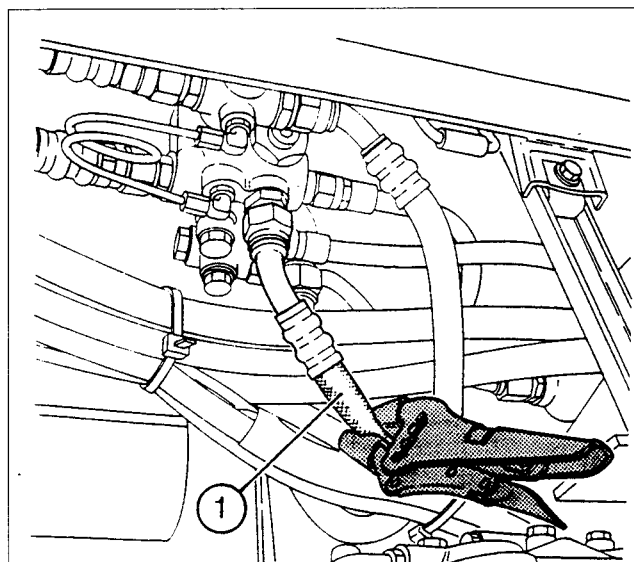

Fig. 8

Fig. 7



4A01.10

## 6100 SERIES TRACTORS

**Clutch** - Pressure-loaded**F. Adjusting the clutch pedal (Fig. 9)**

88. With the clutch pedal (1) at the stop (2), adjust in order to obtain a clearance of 0.5 to 1 mm between the push-rod (3) and the master cylinder piston. Tighten the locknut (4) to a torque of 15 to 20 Nm.
89. Check that the pedal operates freely.

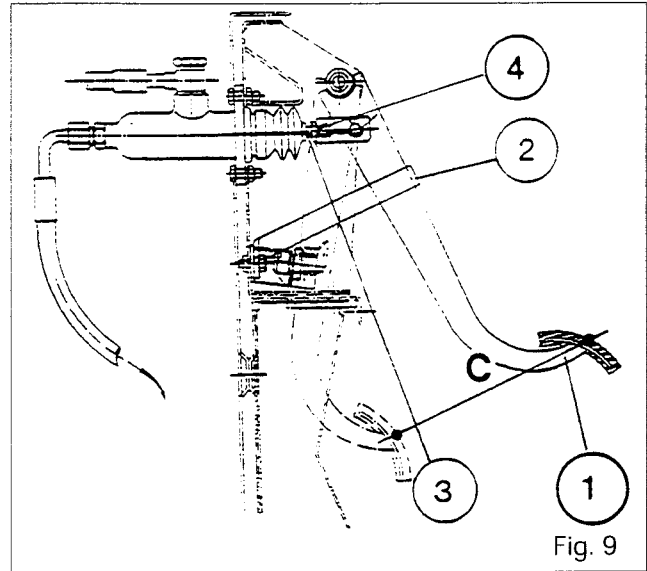

Fig. 9

**G. Service tools****Tools available through the MF Network**

3378012M1 - Protector (Fig. 10)

**Tools to be manufactured locally****- Compression tool (piston return spring)**

- 1 - Flat 60 x 12
- 2 - Threaded rod, 8 dia.

**- Sleeve for removal/refitting of clutch assembly**

- 3 - Tube: Tu52B, 42.4 outside dia., 5 thk
- 4 - Tube: Tu52B, 48.3 outside dia., 2.9 thk

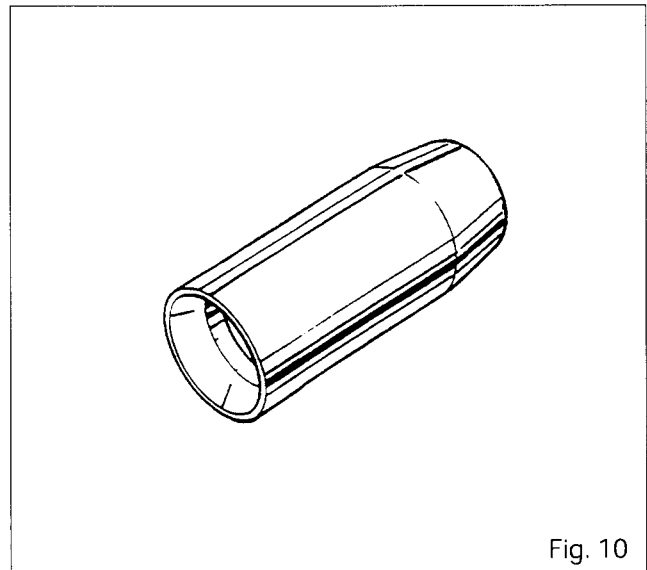
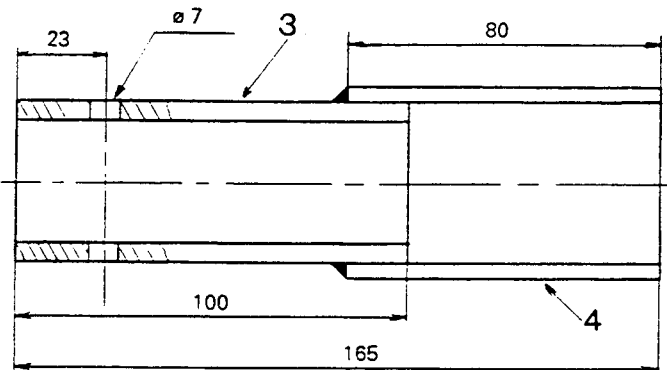
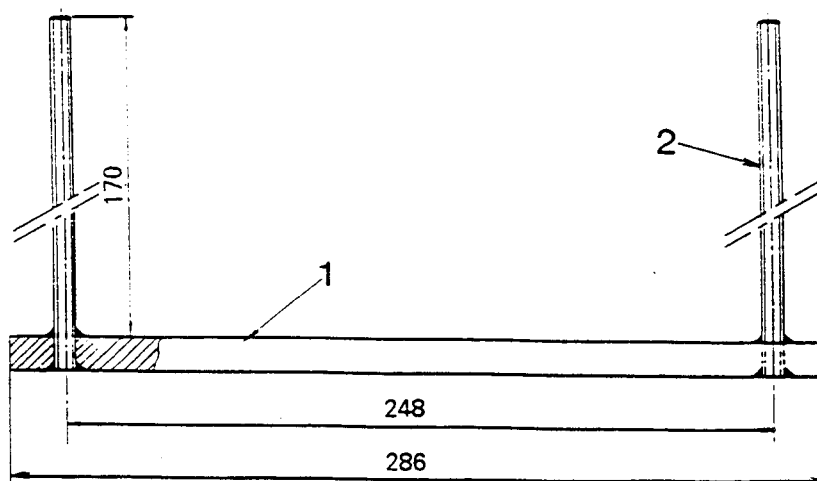

Fig. 10







## Clutch - Pressure-loaded

### H. Speedshift version (Fig. 12)

On Speedshift tractors of types 6170 - 6180 - 6190, the procedure for work on the wet clutch is identical to that for the Dynashift version.

The housing (76) attached to the Speedshift housing with bolts (77) supports the bearing (36) of the clutch assembly (47).

#### Special points

The sealed side of the bearings (36) and (40) faces the Speedshift:

- on cover (76) align the connection holes between the clutch and the gearbox housing.
- tighten the bolts (77) to between 25 and 35 Nm,
- C: with O-ring,
- pipe (73) (clutch supply) (Fig. 11).

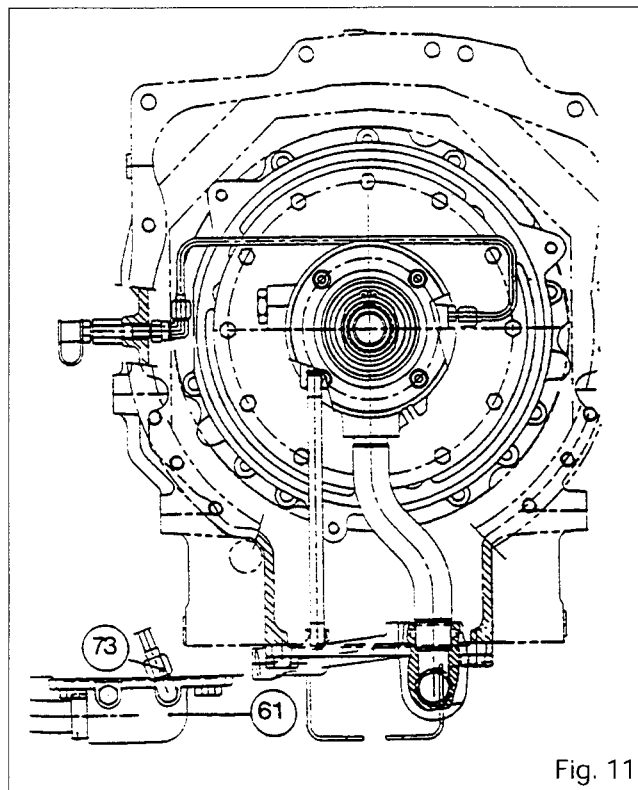

Fig. 11

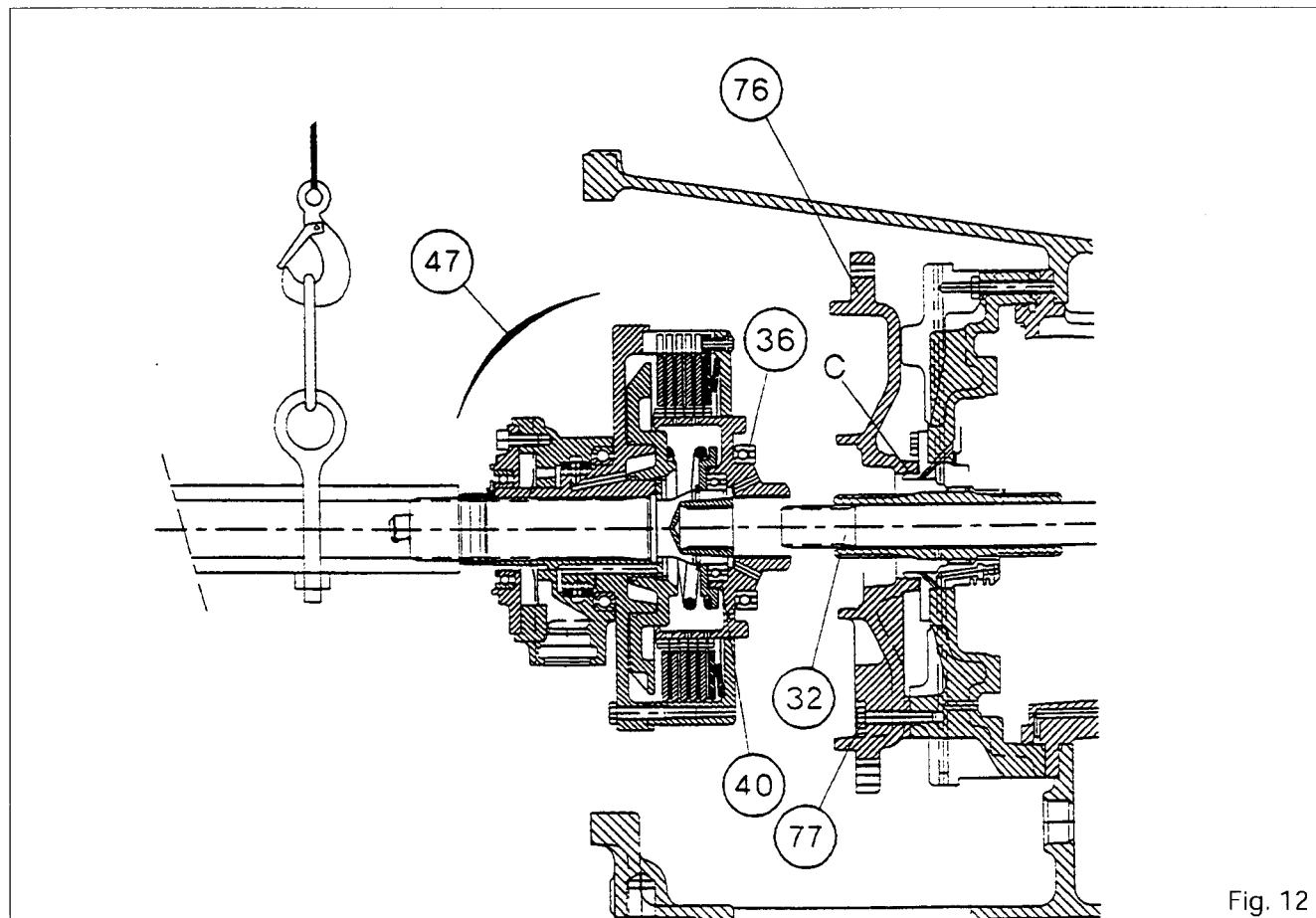

Fig. 12





## **Clutch** - Spring loaded

### 4 B01 Spring loaded clutch

#### CONTENTS

-	<b>General</b> _____	<b>2</b>
A.	<b>Removing and replacing the oil seal and the O-ring</b> _____	<b>6</b>
B.	<b>Removing and replacing the housing and the clutch</b> _____	<b>6</b>
C.	<b>Dismantling, assembling, and adjusting the clutch</b> _____	<b>7</b>
D.	<b>Bleeding the clutch</b> _____	<b>10</b>
E.	<b>Adjusting the clutch pedal</b> _____	<b>10</b>
F.	<b>Service tools</b> _____	<b>11</b>
G.	<b>Speedshift version</b> _____	<b>12</b>



## 6100 SERIES TRACTORS



4B01.2

# Clutch - Spring loaded

## General

The 6100 Series tractors with not exceeding than 100 HP are fitted with an oil-bathed multi-disc spring loaded clutch (Belleville springs).

This system has the following advantages:

- Improved reliability
- good progressivity
- possibility of hauling a trailer
- no swivelling joints

The clutch is moved by Belleville springs. This mechanical action permits the clutch to remain engaged, even when the engine is stopped and there is no hydraulic pressure.

The hydraulic pressure is only used to disengage the clutch. Given that this pressure is generated directly by the clutch master cylinder, the clutch can be disengaged even when the engine is stopped.

## Construction

The wet clutch is set between the flywheel and the Speedshift or

### Releasing the clutch

When pressure is applied on the clutch, the master cylinder sends pressurized oil to the release bearing piston (46) through a hose connected on the left side of the gear housing, an internal tube and a channel inside the clutch case.

The release bearing (46) presses against the clutch cover (23) which moves backwards and compresses the two Belleville springs (4) against the plate (41), freeing the discs (44).

### Engaging the clutch

When the clutch pedal is released, the Belleville springs (4) move the clutch cover (23) forward. The discs and the intermediate plates are compressed against the plate (41) and the rear side of the clutch box (39). The clutch but (46) is maintained in contact by oil at a very low pressure coming from the leveling circuit through the master-cylinder. The load of the Belleville springs is adjusted by means of shims (52) placed in the corner of the clutch cover (23).

## Engagement

When the pedal is released, the housing (39) moves forward and comes into contact with the discs. The contact between the discs and the intermediate plates is absorbed by the progressive washer (6). The clutch can then transmit a low drive ensuring the progressivity of the engagement. The entire engagement is carried out by the two Belleville springs (4).

## Parts List

- (1) 'O' Ring
- (2) Housing
- (3) 'O' Rings
- (4) Belleville spring
- (5) Screw
- (6) Progressive washer
- (7) Input shaft
- (8) 'O' Ring
- (9) Cover
- (10) Tube
- (11) Pump cover
- (12) Stud
- (13) Cover
- (14) 'O' Ring
- (15) 'O' Ring
- (16) 'O' Ring
- (17) Tube
- (18) Screw
- (19) Flange
- (20) Tube
- (21) Spacer
- (22) Screw
- (23) Clutch cover
- (24) Lock pin
- (25) Flange
- (26) Screw
- (27) Dust guard
- (28) 'O' Ring
- (29) 'O' Ring
- (30) Suction block
- (31) Screw
- (32) PTO shaft
- (33) Primary shaft
- (34) Circlip
- (35) Washer
- (36) Roller bearing
- (37) Driving hub
- (38) Screw
- (39) Housing
- (40) Roller bearing
- (41) Pressure plate
- (42) Tube
- (43) Circlip
- (44) Discs
- (45) Intermediate plates
- (46) Release bearing
- (47) Clutch assembly
- (48) Quadring seal
- (49) Quadring seal
- (50) Nut
- (51) Tube
- (52) Shims
- (53) Lubrication pump
- (54) Screw
- (55) Roller bearing
- (56) Fitting
- (57) Oil seal
- (58) Grommet
- (59) Spacer
- (60) Screw
- (61) Cover
- (62) Strainer
- (63) 'O' Ring
- (64) Fitting
- (65) Tube
- (67) Bleeding port
- (72) Fitting
- (74) Plug
- (75) Screw
- (76) Dynashift feed tube
- (77) Screw



6100 SERIES TRACTORS

**Clutch - Spring loaded**



4B01.3

General view

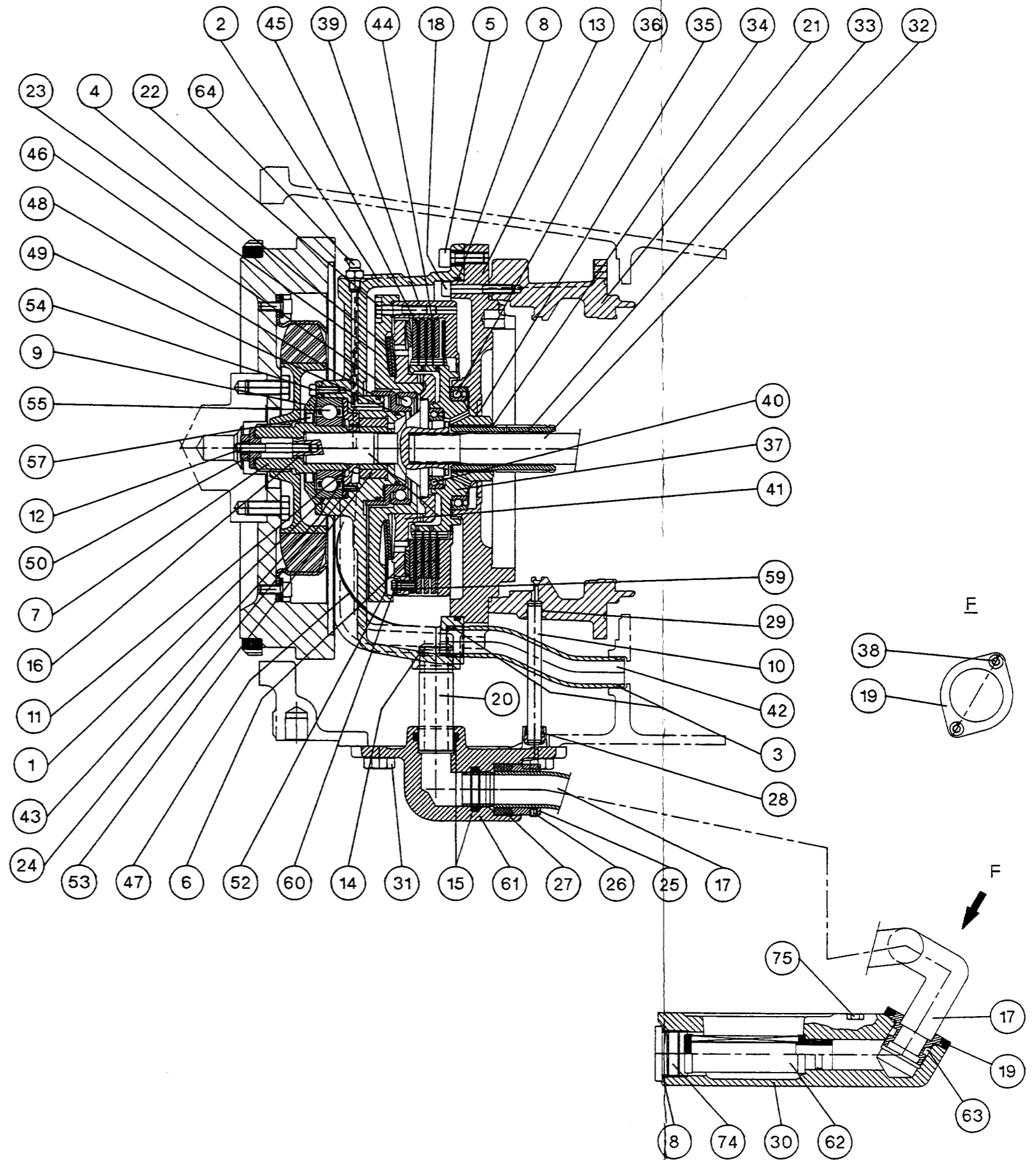
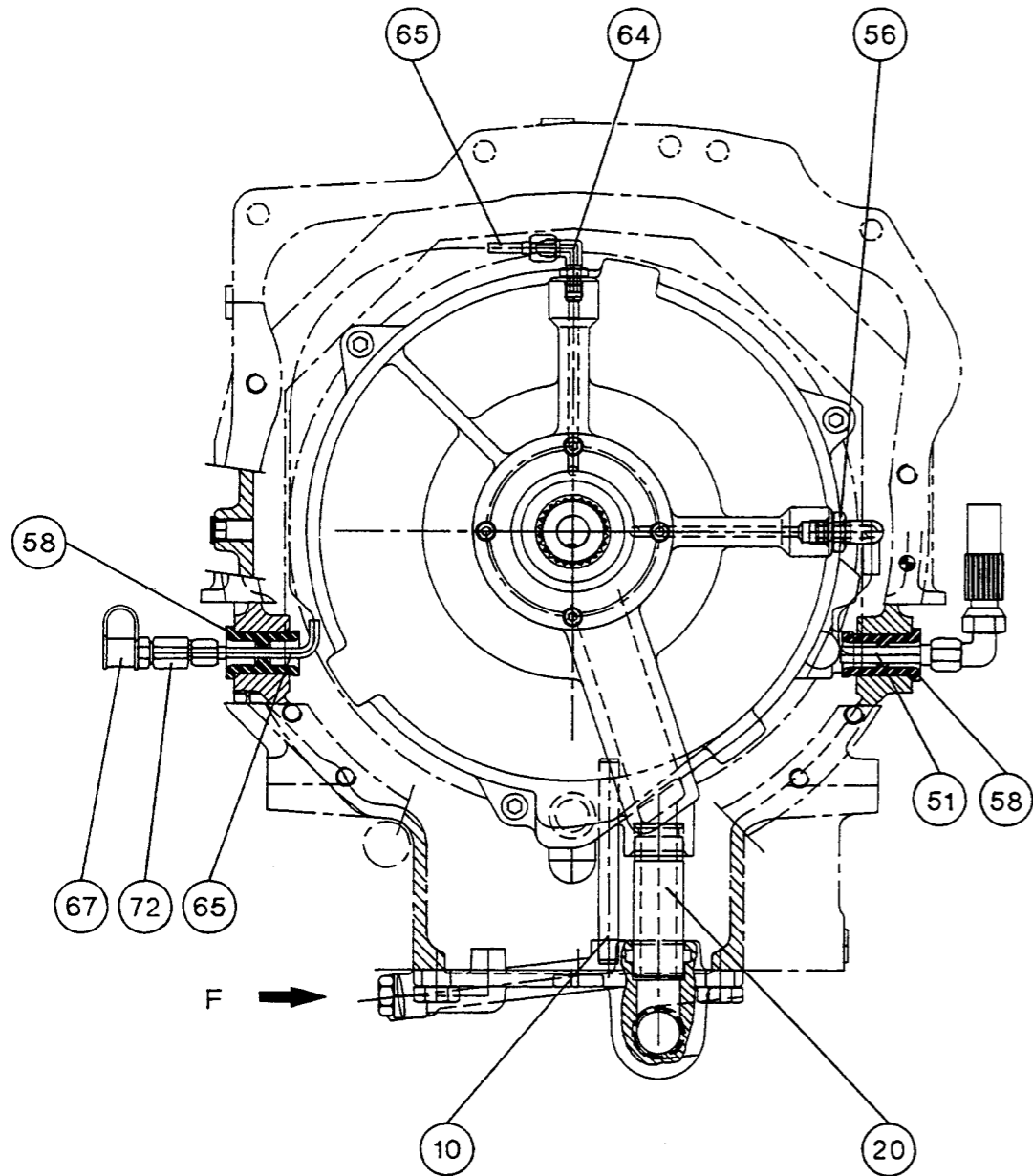



4B01.4

6100 SERIES TRACTORS



Clutch - Spring loaded

Exploded view

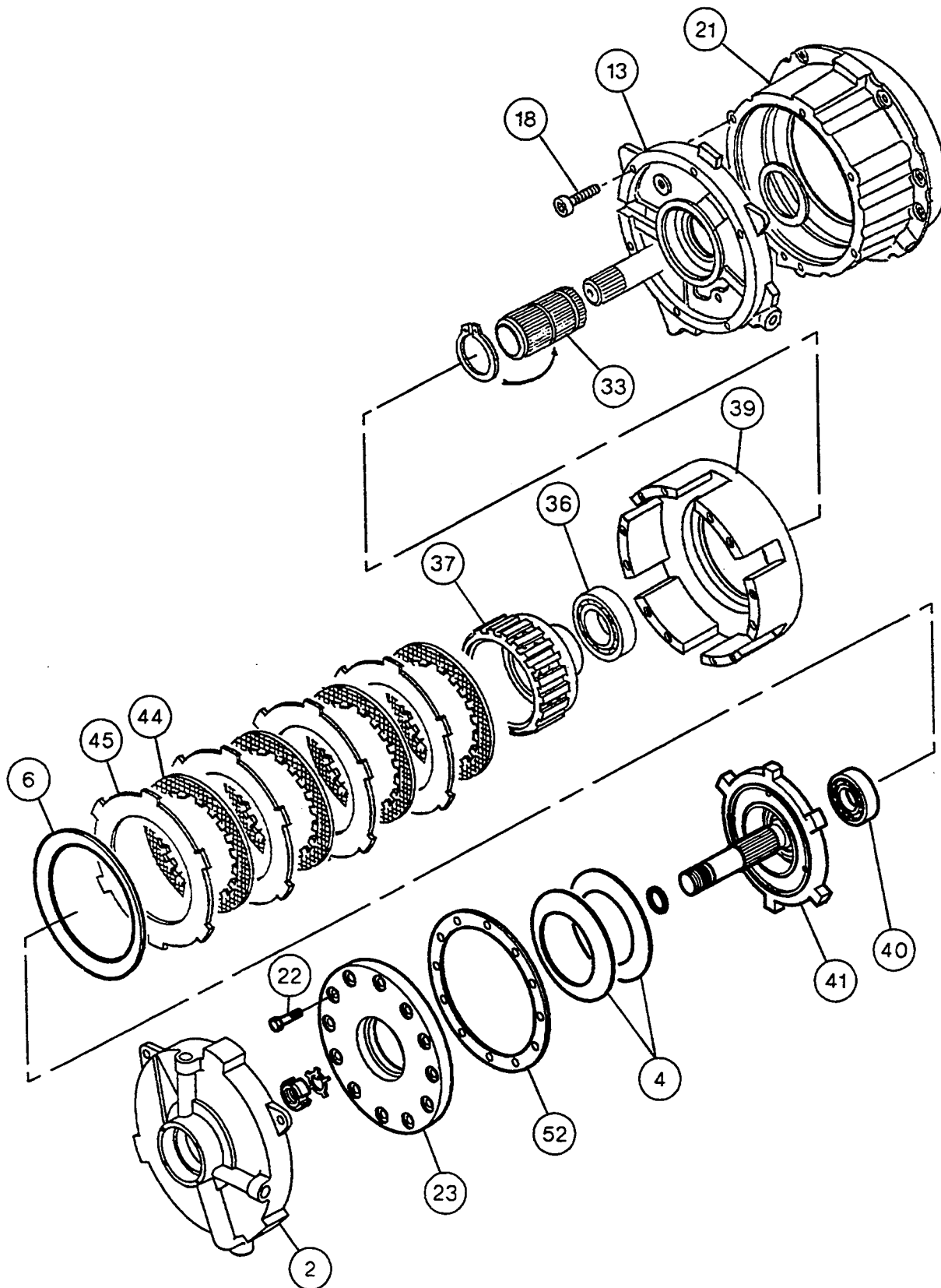

Fig. 2



**Clutch - Spring loaded**

4B01.5

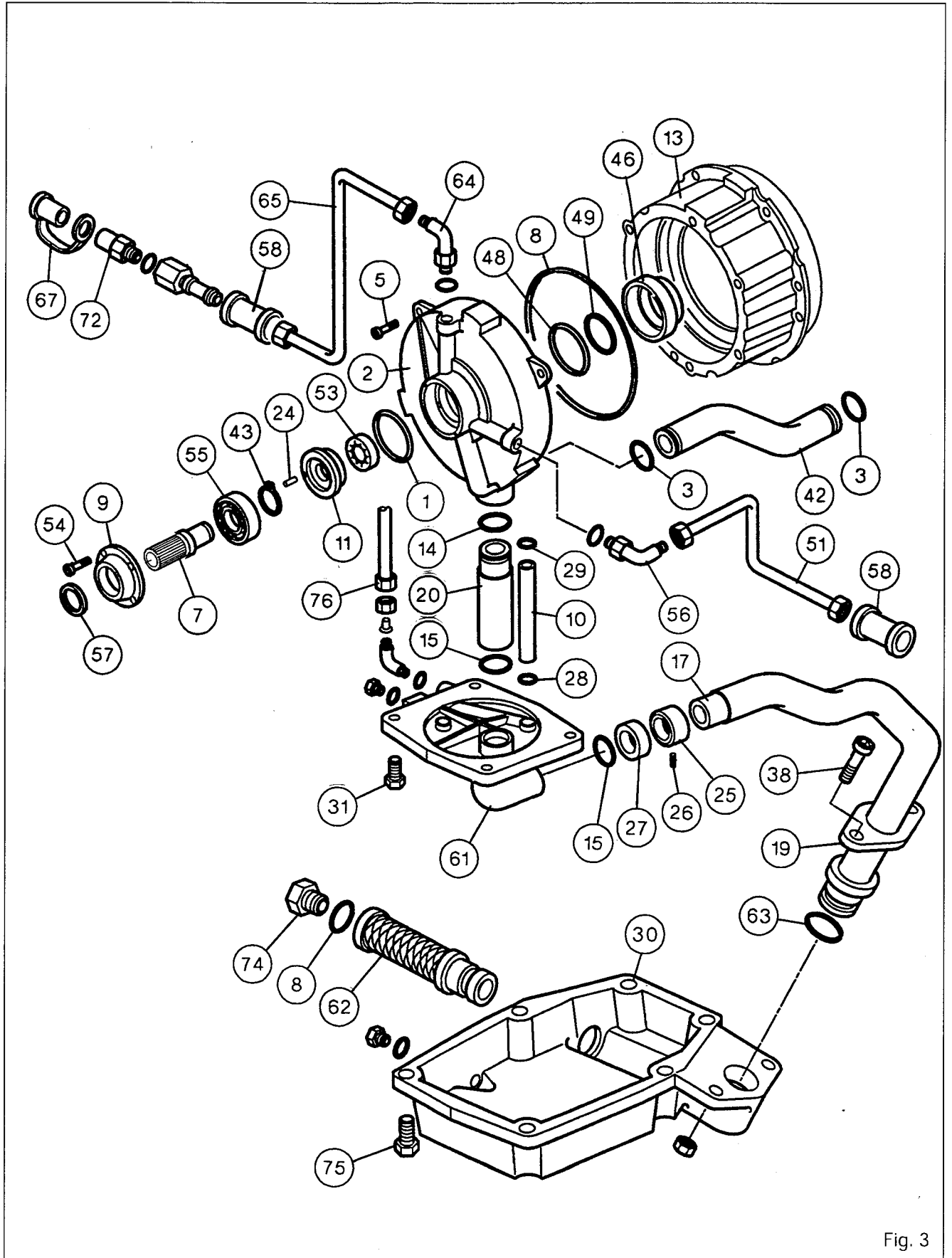

Fig. 3



4B01.6

## Clutch - Spring loaded

### A. Removing and replacing the oil seal (57) and the O-ring (1)

#### Removal.

1. Split the tractor between the engine and the gearbox, section 2 A01.
2. Place the protector Nr. 3378052M1 over the input shaft (7) (§F). Remove the screws (54). Remove the case (9) and the O-ring (1).
3. Extract the oil seal (57) (Fig. 3A).

#### Replacement

4. Mount properly by press-fitting oil seal. Replace the O-ring. Apply a film of oil on the O-ring (57). Replace the protector. Mount the case. Torque screws (54) to 10-14 Nm using a torque wrench.  
**Important : After the screws (54) have been torqued it is normal to see a gap (0 to 0,3) between the cover (9) and the housing (2).**
5. Re-assemble the gearbox to the engine.

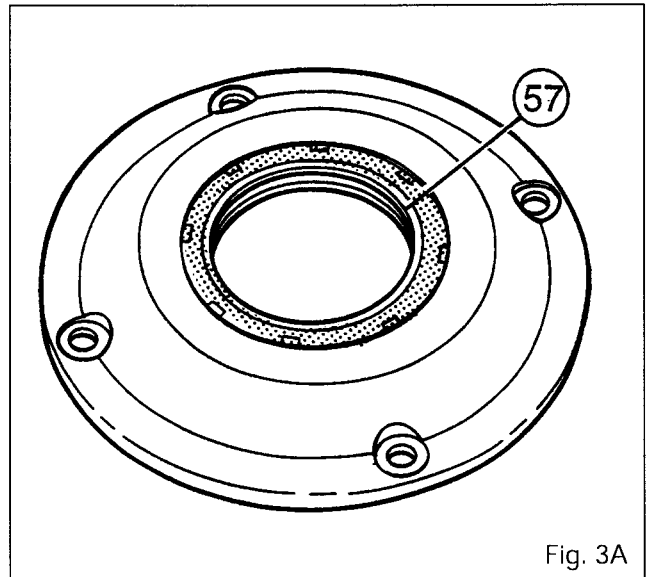

Fig. 3A

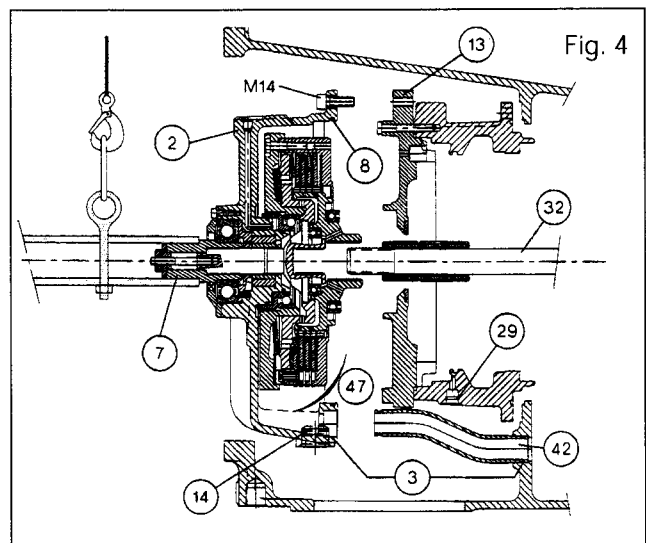

Fig. 4

### B. Removing and replacing the housing (2) and the clutch (47)

#### Removal

6. Separate the engine from the gearbox, section 2A01.
7. Empty the gearbox and the live rear axle.
8. Remove the tube (76). Unscrew and remove the cover (61), the flange (19), and the tube (17).
9. Remove the grommet (58), the tubes (10) (20) (65) (51), and the fittings (56) (64).
10. Place the on-site made tool (§ F) on shaft (7) (Fig. 5). Clean screw holes (5). Place three M 14 screws in the threaded holes in the housing. (2). Tighten the screws at uniform pressure and alternatively, in order to extract the housing and the gear assembly (47) (Fig.4).  
After extraction, block the PTO shaft (32) using a pair of combination pliers, to facilitate the removal of the housing and the gear assembly.
11. Remove the tube (42) and, if necessary, the PTO shaft.

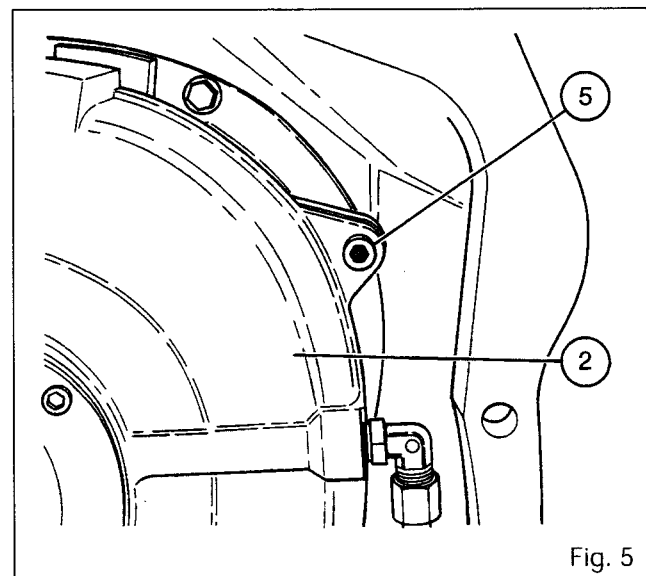

Fig. 5





## Clutch - Spring loaded

4B01.7

### Refitting

12. Refitting the PTO shaft (if it had been removed).
13. Replace the O-rings **(3)** **(8)** **(14)** **(29)**.
14. Refitting the tube **(42)** (Fig. 4).
15. Screw three "G" guide studs on the cover **(13)** (Fig.6).  
Using the tool employed in the operation 10, re-install the clutch assembly **(47)** and the housing **(2)**. Remove the guide studs. Use screws **(5)** to facilitate casing **(2)** engagement on cover **(13)**. Guide tube **(42)** so it can easily be fitted in casing **(2)** (Fig. 4). Once assembly is completed, check that it is correctly mounted without being clamped.
16. Tighten the screws **(5)** at 72 - 96 Nm.
17. Replace the O rings **(15)** **(28)**. Re-install the fittings **(56)** **(64)**, the tubes **(10)** **(20)** **(65)** **(51)**, and the grommet **(58)**.
18. Clean the surfaces of the housing gasket on the gear housing and the cover **(61)**. Apply Loctite 510 or an equivalent on the surface of the housing joint.
19. Replace the dust guards **(27)** and the O-ring **(63)**.
20. Re-install the tube **(17)**, the flange **(19)**, and the cover **(61)**. Tighten the screws **(31)** to 200 - 260 Nm.
21. Tighten the screws **(38)** to 41 - 53 Nm, as well as the screw **(26)**.
22. Reconnect the tube **(76)**.
23. Introduce oil in the central housing.
24. Re-assemble the tractor between the engine and the gear housing (section 2 A01).
25. Bleed the clutch control (see § D).
26. Check the PTO clutch operation.
27. Make a trial run.
28. Check the flange **(19)** and cover **(61)** for any leaks.

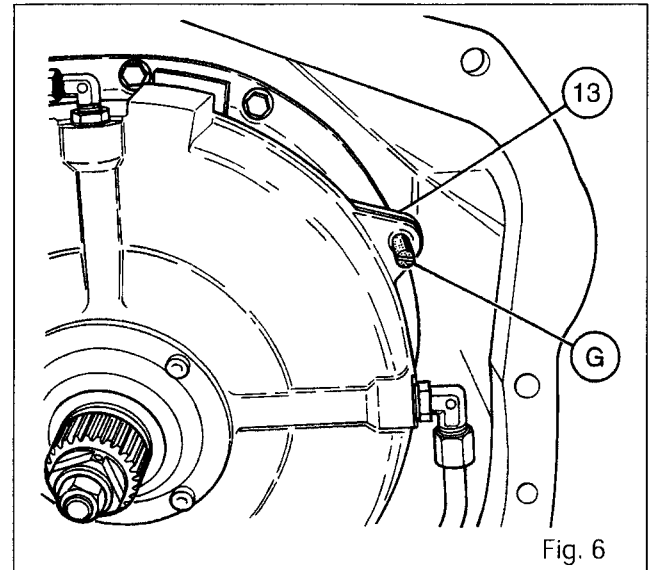

Fig. 6

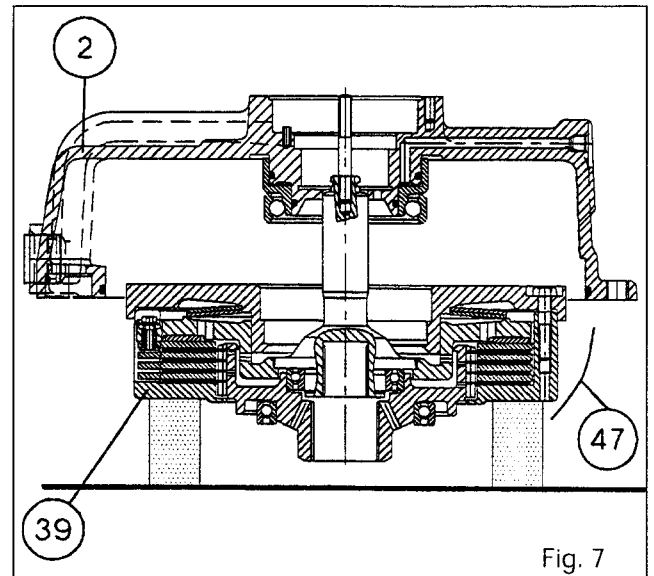

Fig. 7

## C. Dismantling, assembling, and adjusting the clutch

### Dismantling the clutch

#### On the housing (2)

29. Remove the nut **(50)**. Place the housing and clutch assembly vertically, with the housing **(39)** resting on a support (Fig. 7).
30. Remove the screws **(54)**. Remove the cover **(9)** with its oil seal.
31. Remove the O ring **(1)**.
32. Extract the input shaft **(7)**. Remove the circlip **(43)**. Extract the roller bearing **(55)**.

33. Remove the pump cover **(11)** and the lubrication pump **(53)**.
34. Separate housing **(2)** from the clutch **(47)** (Fig. 7).
35. Remove the release bearing **(46)** using compressed air.
36. Remove the quading seals **(48)** **(49)**.
37. If necessary, remove the lock pin **(24)**.



4B01.8

## Clutch - Spring loaded

### On the Clutch cover (23)

38. Remove the screws (22). Separate the cover (23) from the housing (39). Remove the shims (52) and the Belleville springs (4).
39. Remove the pressure plate (41). Extract the screws (60) and the spacers (59). Remove the first intermediate plate (45) (68) and the progressive washer (6).
40. Remove the discs, the intermediate plates (45), and the hub (37).
41. If necessary, extract the bearings (36) and (40).

### Refitting

#### On the clutch cover

42. Refit the bearings (36) (40), if they were removed, respectively on the driving hub (37) and the plate (41).
43. Place the driving hub in the housing (39).
44. Dip the discs in transmission oil. Ensure that they are well covered by the oil.
45. Place the plates (45) and the discs (44) on the driving hub (37), and align their notches.

#### Adjusting the clutch

Parts involved the adjustment:

Cover (23), Belleville spring (4), Pressure plate (41), Progressive washer (6), Counterplate (68), Discs (44), Plates (45), Housing (39).

46. Place first the intermediate plate (41) with progressive washer (6) set as shown in figure 8, shims (59) and screws (60) torqued to 2.2 - 3 Nm on pressure plate (41).
47. Mount pressure plate (41) assembled in box (39) (Fig. 10).

**Note: The stud (12) should be secured using Loctite 270.**

48. Using a depth gauge, measure the side between faces B and C, taking face A as reference (Fig. 9) (the inner diameter of the Belleville springs (4) that outer diameter contacts D face).
49. Using the service tool Nr. 3378053M1, compress the progressive washer (6) under a load of 1000 daN (Fig. 10).
50. Measure the distance between two diametrically opposed locations on D and E faces (Fig. 10). Compute both readings average (Belleville springs (4) outer diameter contacts D face).
51. Apply the formula  $(B-C) + (D-E)$  to define the total distance between the faces D and B.

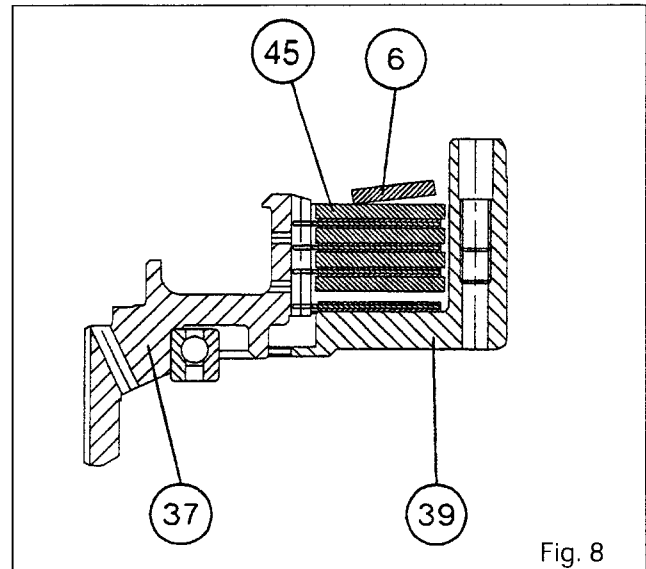

Fig. 8

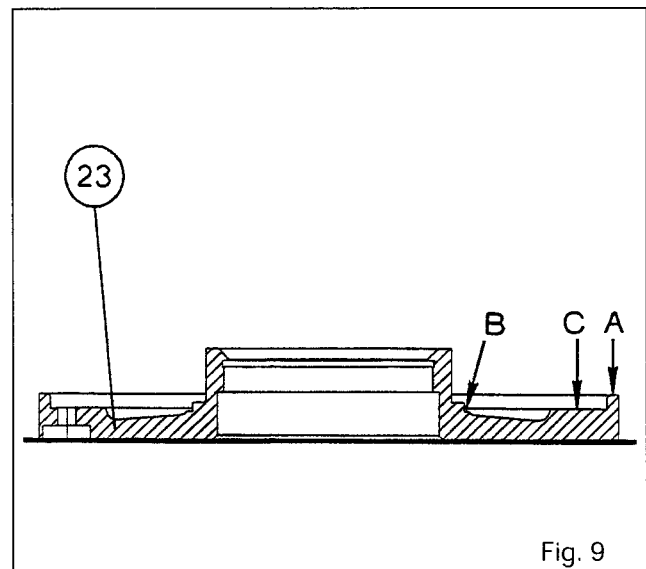

Fig. 9

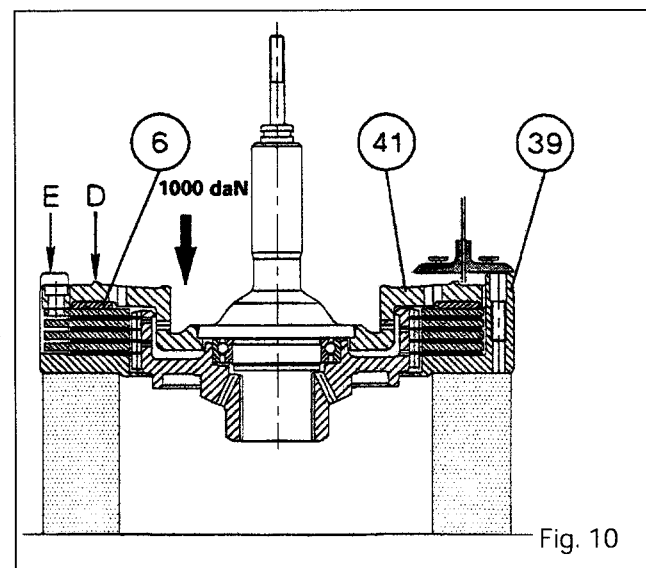

Fig. 10



## Clutch - Spring loaded

52. Add the width of a shim (52) to this total distance, to obtain an "H" height of the Belleville springs (4) ranging between 7.35 and 7.55 mm. (Fig. 11).
53. Assemble Belleville springs (4) by applying miscible grease on three locations. Properly align Belleville springs with "D" mating surface center (Fig. 12).
54. Screw two guide studs diametrically opposed on box (39). Place wedges (52) selected in item 52 according to Fig. 11.
55. Mount cover (23) without moving Belleville springs (4). Torque screws to 25 - 35 Nm.

### On the casing

56. Clean and check the parts, replacing any which may be defective.
57. Check that the grooves in the housing (2) are not blocked.
58. Replace the stud (24), if it is out.
59. Lubricate and install the quading seals (48) (49) in the housing.
60. Press fit the release bearing (46).
61. Install the housing (2) on the clutch assembly (47) (Fig. 7).
62. Grease and install the pump (53).
63. Mount the pump cover (11) with the hole marked "T" directed towards the lock pin (24) while checking fuel holes alignment (Fig. 13).
64. Fit the roller bearing (55) on the input shaft (7).
65. Mount the circlip (43).
66. Place the greased O-ring (16) on the plate shaft (41).
67. Mount the input shaft in the housing (2). Place the O-ring and the protector (No. 3378052M1) (1). Mount the cover (9) with its oil seal (57). Torqu screws (54) to 10 -14 Nm with a torque wrench.
68. Tighten the nut (50) to 25 - 32 Nm. Apply Loctite 542.

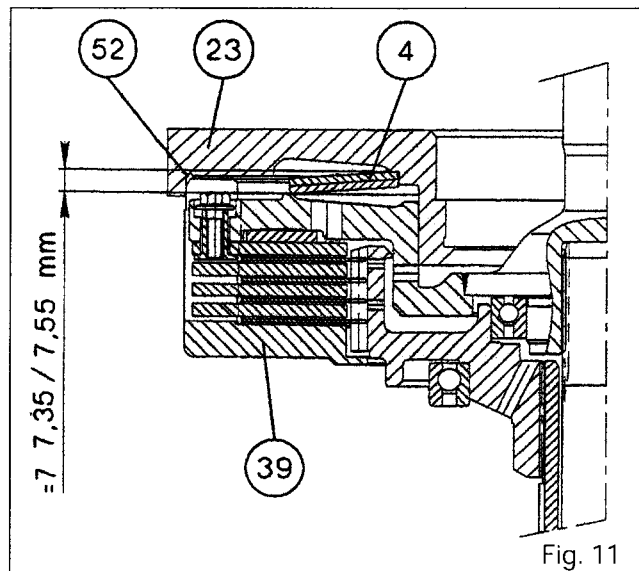

Fig. 11

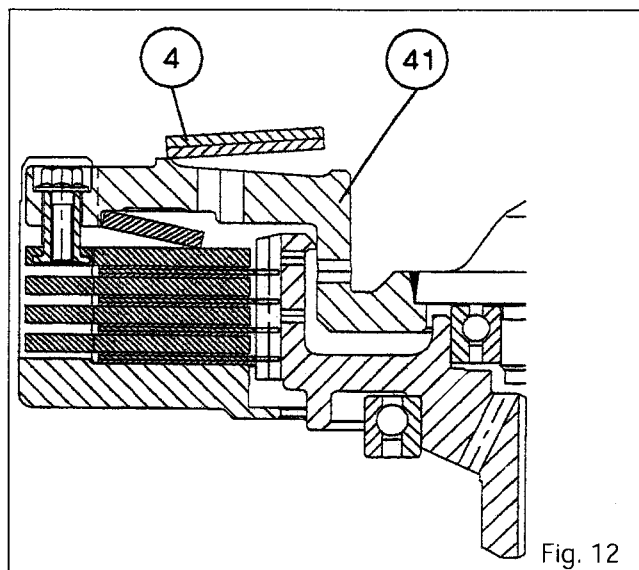

Fig. 12

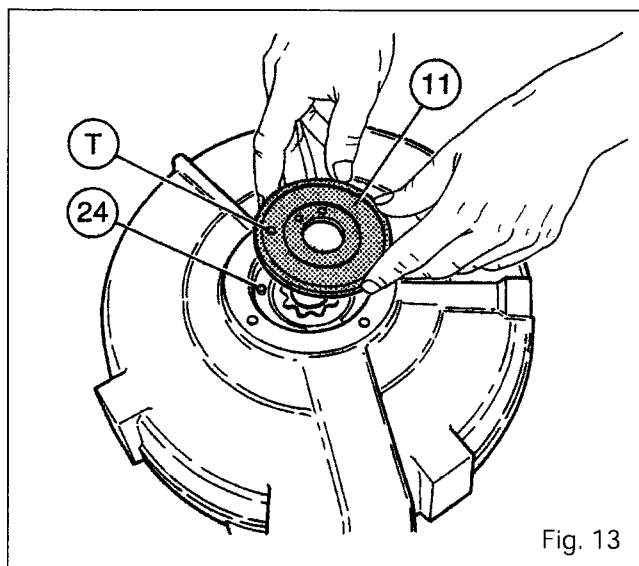

Fig. 13



4B01.10

# Clutch - Spring loaded

## D. Bleeding the clutch control

- 69. Run the engine at about 1200 r.p.m.
- 70. Taking care to protect them, pinch the return hose(s) **(1)** according to the following serial numbers :
  - Fig. 14A : up to No. D086000 (6100 std) and D115016 (6100 steep nose).
  - Fig. 14B : from No. D086001 (6100 series) and D115017 (6100 steep nose).
- 71. Connect the union No 3582045M1 and its pipe on the bleed connector **(67)** as shown in Fig. 15.
- 72. Gradually press the clutch pedal.
- 73. Check the adjustment of the clutch pedal (§ E).
- 74. Carry out a road test.

### Tractors equipped with closed centre hydraulic system (Fig. 7C)

- Use the same method and correctly identify the return hose **(1)** located to the front left-hand side of the gearbox. Block the return hose with a clamp fitted with suitable protection.

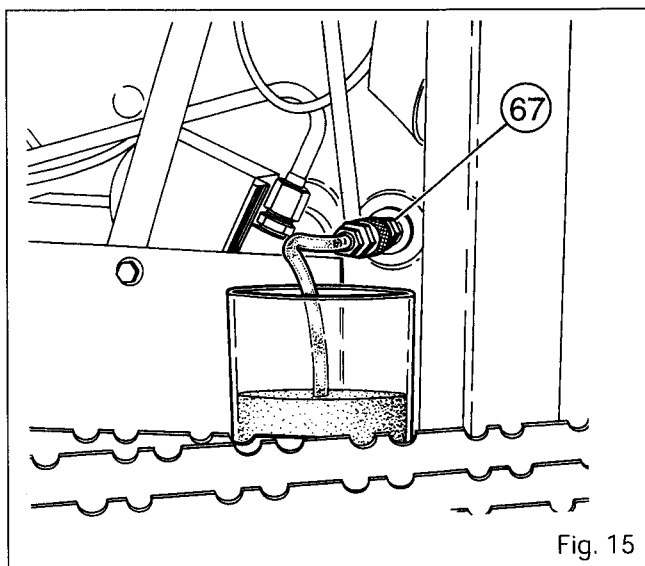
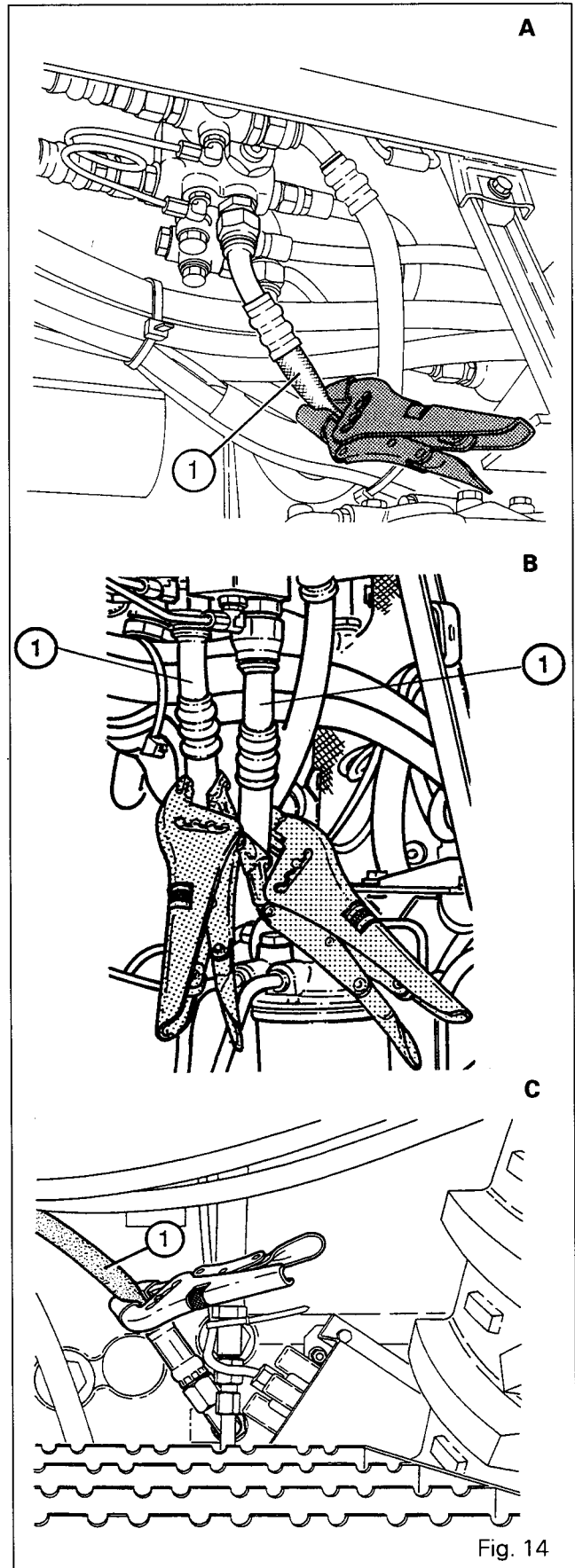

Fig. 15

Fig. 14



## Clutch - Spring loaded

### E. Adjusting the clutch pedal (Fig. 16)

75. Adjust stop screw (5) so that clutch pedal stroke is 215 mm between released (pedal contacting the stopper (2)), and engaged positions. Tighten lock-nut (6). Bring pedal (1) in contact with stop screw (5).

Adjust gap between push rod (3) and master-cylinder rod to 0.5 - 1 mm by adjusting push-rod. Tighten the lock-nut (4) to 16 - 20 Nm.

76. Check that the pedal operates freely.

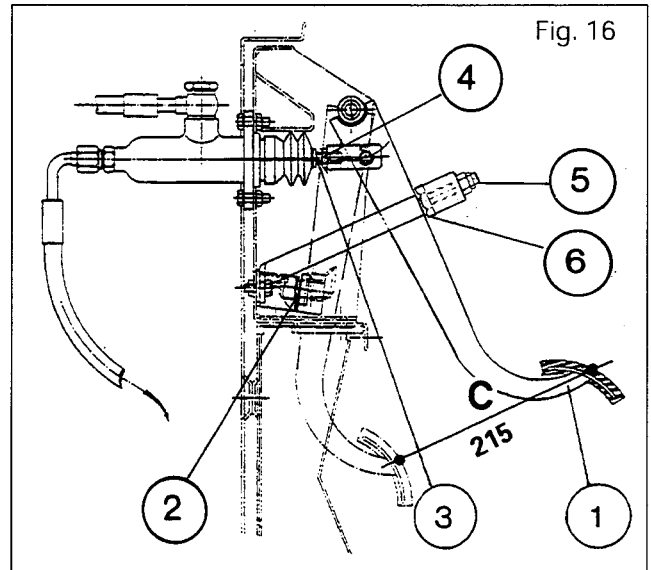

### F. Service tools

1. Tools available through the MF Network  
**3378052M1 - Protector (Fig.17).**  
**3378053M1 - Progressive washer compression tool**

2. Tool to be manufactured locally

**Sleeve for removal/refitting of clutch assembly**

3. Tube Tu52B Ø ext. dia. 42.4 epr 5

4. Tube Tu52B Ø ext. dia. 48.3 epr 2.9

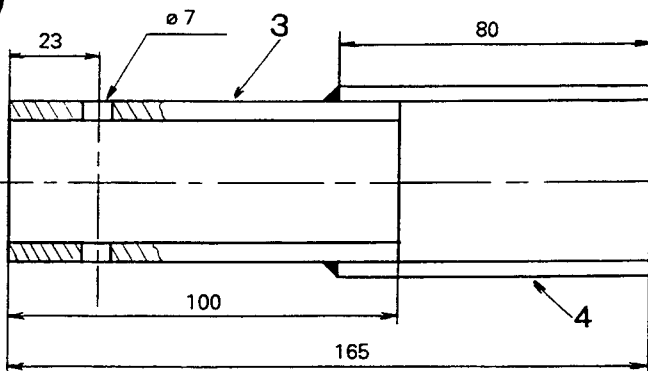
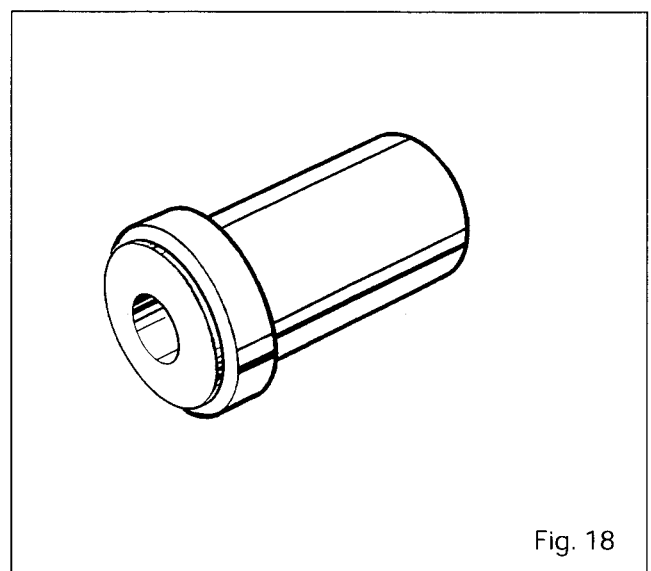
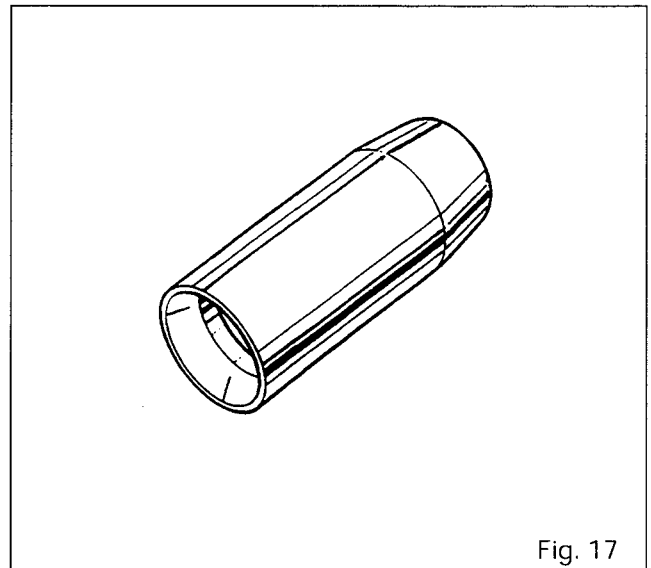



4B01.12

## 6100 SERIES TRACTORS

**Clutch - Spring loaded****G. Speedshift version (Fig. 20)**

The repair method on the Speedshift tractors is similar to that on the Dynashift version.

The housing (13) attached to the Speedshift housing cover using the screws (77) supports the bearing (36) of the clutch assembly (47).

**Points of interest**

The sealed side of the bearings (36) (40) must face the Speedshift.

Align holes providing for communication between clutch and transmission case on clutch cover (13).

- Tighten the screws (77) to 25 - 35 Nm.
- Place an O ring on C
- Apply Loctite 510 on D
- Cover (61), Speedshift version (Fig. 19)

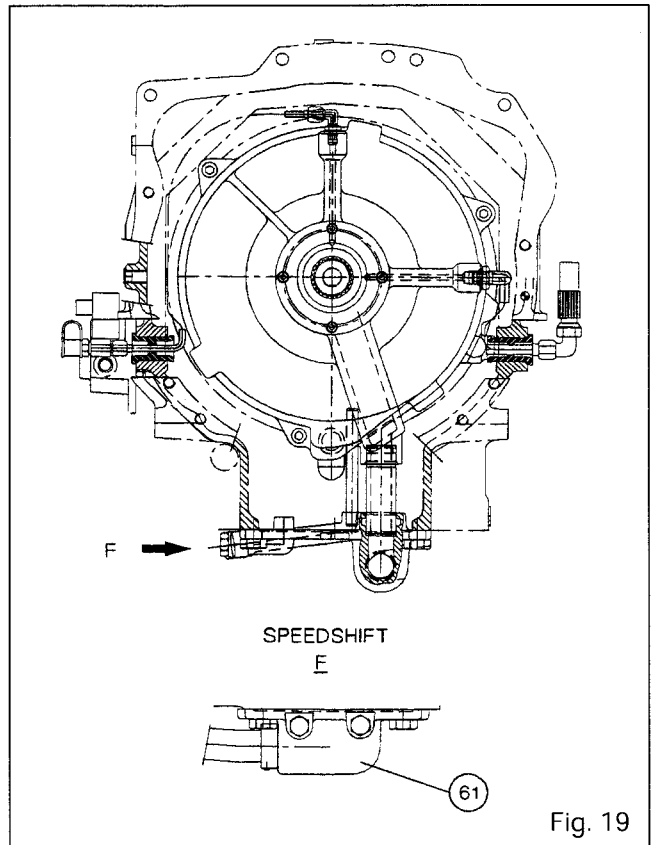

Fig. 19

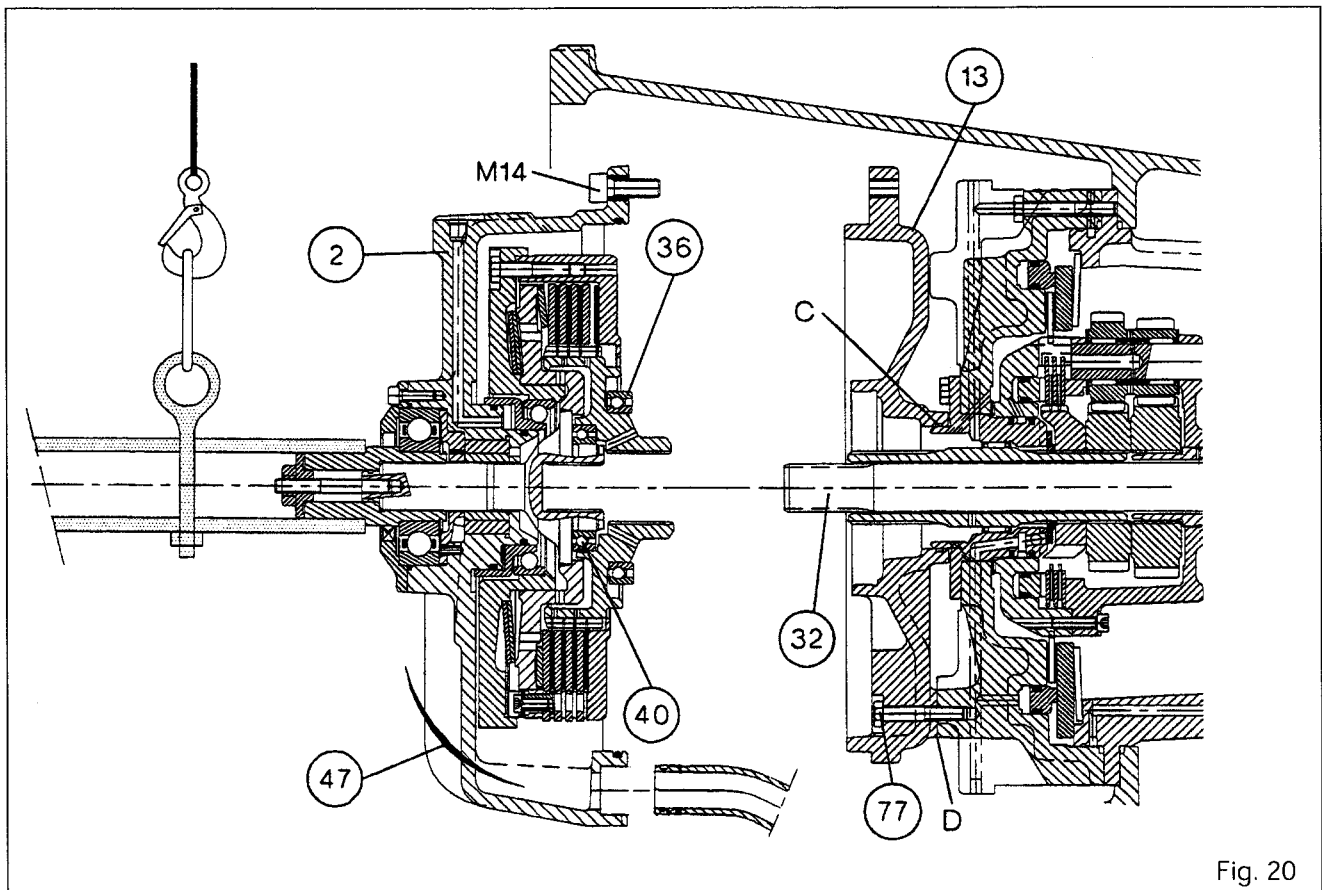

Fig. 20



## 5 . GEARBOX

### Contents

#### STANDARD GEARBOX

5A01	TRANSMISSION ASSEMBLY
5B01	INPUT UNIT
5B03	DYNASHIFT
5B04	REVERSE SHUTTLE
5C01	SELECTOR COVER ELECTROHYDRAULIC CONTROL
5C02	SELECTOR COVER MECHANICAL CONTROL
5D01	SELECTOR RAIL AND FORKS
5E01	OUTPUT SHAFT
5F01	LAYSHAFT
5G01	MAINSHAFT
5H01	CREEPER GEARS
5H02	SUPER CREEPER GEARS

#### HEAVY DUTY GEARBOX

5A02	MAIN GEARBOX
5B02	SPEEDSHIFT
5B03	DYNASHIFT
5B04	REVERSE SHUTTLE
5C01	SELECTOR COVER ELECTROHYDRAULIC CONTROL
5C02	SELECTOR COVER MECHANICAL CONTROL
5D01	SELECTOR RAIL AND FORKS
5E02	OUTPUT SHAFT
5F02	LAYSHAFT
5G02	MAINSHAFT
5H01	CREEPER GEARS
5H02	SUPER CREEPER GEARS







5 A01 *Transmission assembly*

CONTENTS

A.	<b>Description</b> _____	2
B.	<b>Gearbox assembly</b> _____	2
C.	<b>Main gearbox</b> _____	4
D.	<b>Specifications: transmission with pressure-loaded clutch</b> ____	7
E.	<b>Specifications: transmission with spring-loaded clutch</b> ____	8



5A01.2

## 6100 SERIES TRACTORS



# Gearbox - Transmission assembly

### A. General description

6100 series tractors are equipped with a transmission consisting of five main housings:

- the gearbox assembly which also serves as a clutch housing;
- the centre housing which includes the differential assembly, the power take-off line and the 4WD clutch, and which also holds the side hydraulic covers;
- the right and left hand axle housings;
- the lift cover.

These five parts are common to the whole range of tractors. Models fitted with 6-cylinder engines are equipped with an adaptor plate located between the engine and the gearbox.

#### Clutch

The clutch is of the wet type and is either spring-loaded (tractors in series 6110 to 6160) or pressure-loaded (tractors in series 6170 to 6190).

The clutch lubrication is ensured by a pump which inlet is connected to the centre housing via a 500 micron strainer and a tube fitted under the transmission and a second tube connected to the clutch.

A shaft driven by the engine clutch input shaft passes through the gearbox assembly and transmits rotation to the power take-off clutch.

The power take-off clutch unit drives the hydraulic pump driving gear.

### B. Gearbox assembly

#### Main gearbox

The main gearbox has eight basic speeds. It consists of a train of four gears to which a set of two gears is added so that a slow range (Tortoise) and a fast range (Hare) can be obtained.

All the gears are in constant mesh and the speeds are selected by synchromesh units. These eight speeds can be selected with a single lever.

#### Input gear assembly

The purpose of the input unit, fitted on the front of the gearbox, is to provide the main gearbox with two or four additional gear ranges for the Speedshift version or Dynashift version, respectively.

The reverse gear assembly, located to the rear of the input unit, can be operated either mechanically or electro-hydraulically (optional).

#### Speedshift

In addition to the main box and to the reverse gear assembly, a hydraulic device with an epicyclic gear train located to the front of the reversing gear and operated by a solenoid valve provides another two input speeds, so increasing the possible number of speeds to 16.

#### Dynashift

As an alternative to the Speedshift version, the Dynashift allows four extra input ratios to be added on the main box, bringing the possible number of speeds up to 32. This function is provided by a hydraulically operated system with two epicyclic gear trains and two hydraulic pressure-loaded clutches.

#### Creeper gear unit

A range of greatly reduced tractor speeds can be obtained by means of a unit fitted on the output shaft, to the rear of the main box.

This unit consists of an epicyclic-type reduction gear with a mechanically driven ratio of 4:1, and which should be engaged only if the main box is in the slow position (Tortoise).

#### Lubrication

Lubrication is ensured by means of the 1.5 bar valve located on the left-hand side of the gearbox. The oil flow circulates through the Speedshift or Dynashift assembly, the reverse shuttle and the layshaft bearings as well as in the gears, bearings and bushes of the mainshaft and output shaft.



6100 SERIES TRACTORS



5A01.3

**Transmission assembly**  
(Longitudinal section)

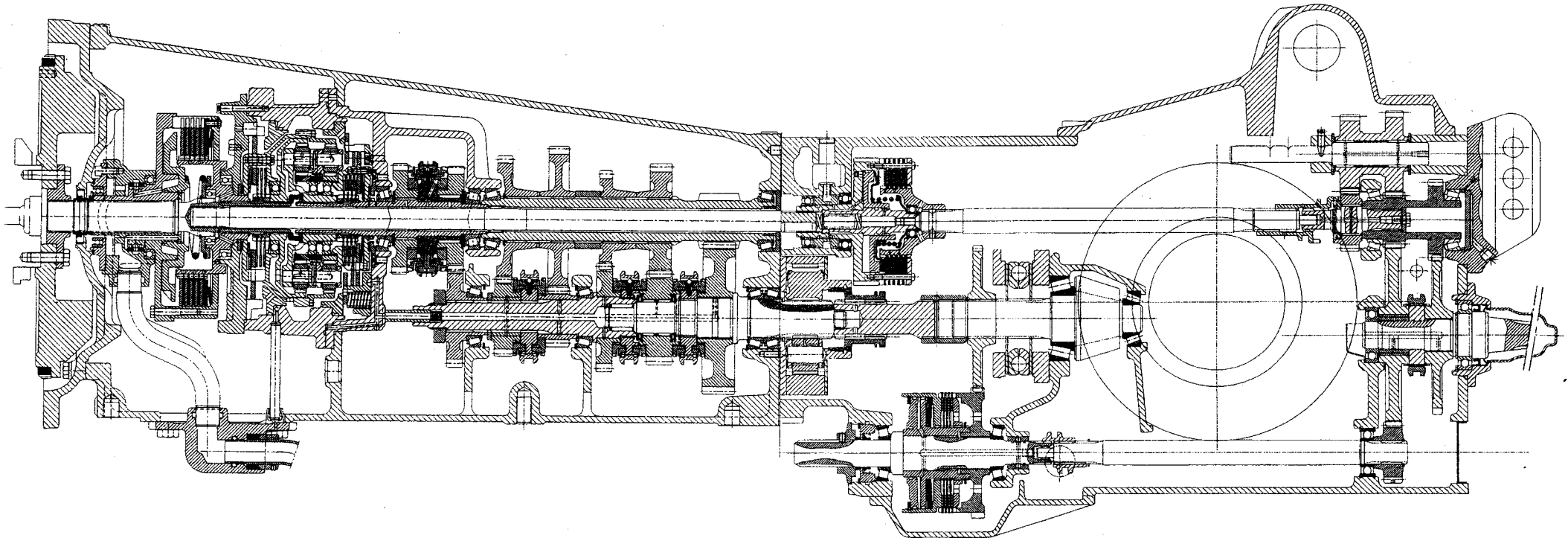



5A01.4

## 6100 SERIES TRACTORS

**Gearbox - Transmission assembly****C. Main gearbox****General**

The gearbox housing comprises the following major components, in this order:

- the engine clutch operating device,
- the input unit containing the Speedshift or Dynashift and the reverse shuttle,
- the main gearbox,
- the creeper gear unit (if fitted).

Here, we will describe only the main gearbox, as each major component is covered by an individual description in the section dealing with it.

**Construction**

The main gearbox has four synchronesh speeds. The initial four speeds can be doubled to obtain the basic eight speeds by means of a gear fitted to rotate freely on the output shaft and which can be locked to the shaft by the coupler. The main shaft and the layshaft are supported by taper roller bearings. The output shaft is fitted in two taper roller bearings and one needle roller bearing. All the gears are helical and in constant mesh. The lubricating oil for the lower shafting comes from the front housing and passes through an oilway drilled along the centreline of the mainshaft and the output shaft. Radial oilways direct oil to the various lubrication points of the gears, bearings and synchronesh devices. The top shafts are lubricated by the film of oil circulating between the PTO shaft and the layshaft. This film lubricates the end taper roller bearings and the needle roller bearings (62). Radial oilways drilled in the shaft (54) and radial grooves on the driven gears provide an oil flow between all the gears. The contact area between the teeth on the shaft (54) and the gear (36) is also lubricated by a radial hole drilled in the shaft. To ensure correct operation, according to the loads placed on the transmission, the bearings are fitted preloaded in the case of the mainshaft or with end float in the case of the layshaft. The output shaft can be shimmed with either a small amount of play or a slight preload.

**Description**

The main gearbox drive is provided by the input gear (67) which is in constant mesh with the rear gear of the reverse shuttle.

The input gear (67) is fitted on the main shaft (69) by means of splines.

The two hubs of the synchronesh devices (11) and (23) are splined onto the mainshaft (69). The 2nd speed driving gear (14) is fitted to rotate freely on a bush (8), the 1st speed driving gear (7) and the 4th speed driving gear (18) are to rotate freely, installed directly on the shaft. The 3rd speed driving gear (29) is fitted on needle roller bearings (28) and (30) which also act as axial thrust bearings. The hub of the synchronesh device (31) is integral with the output shaft (44).

The driven gears (55), (56), (59) and (60) drive the layshaft (54) by splines. The teeth on the layshaft (54) are in constant mesh with the Tortoise gear (36) which is fitted to rotate freely on the output shaft.

**Operation****Low range (Tortoise)**

A speed in the Tortoise range is engaged when one of the couplers of the synchronesh devices (11) or (23) is moved to couple the mainshaft (69) in rotation with one of the four free-running gears. Whatever speed is selected, the motion is transmitted to the layshaft (54). The output shaft (44) is driven by the machined teeth on the layshaft which are in constant mesh with the idler gear (36) fitted on the output shaft by moving the coupler of the synchronesh device (31) rearwards.

**High range (Hare)**

This range is selected when the coupler of the synchronesh device (31) is moved forwards. This places the driving gear (29) in direct mesh with the output shaft. As a result, the layshaft (54) remains non-functional in 3rd gear. The other speeds are obtained by movement of the couplers of the synchronesh devices (11) or (23), in the same way as for the Tortoise range. The motion is transmitted to the output shaft (44) by the driven gears (55) and (29).



6100 SERIES TRACTORS

# Gearbox - Transmission assembly



5A01.5

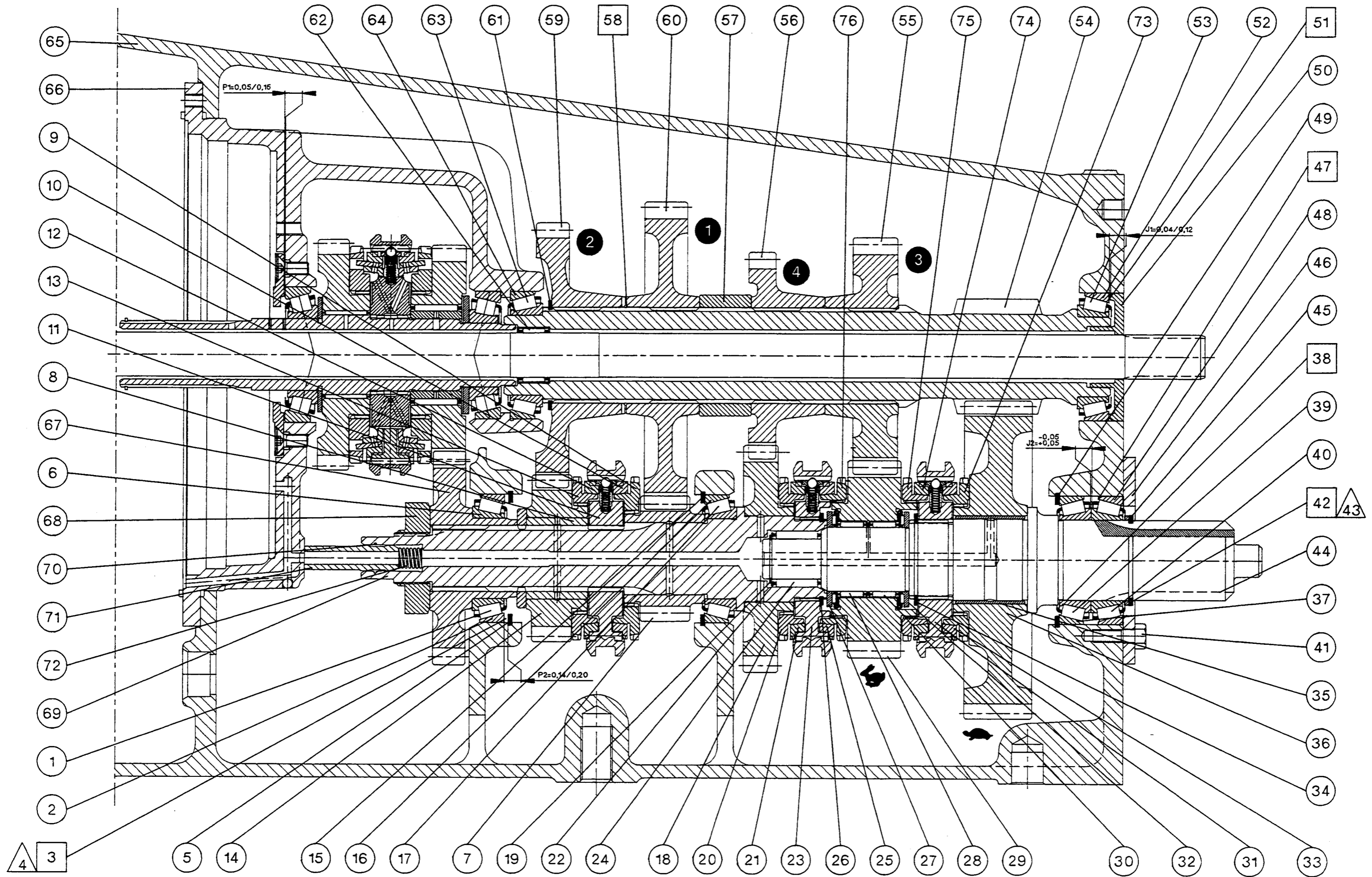



5A01.6

## Gearbox - Transmission assembly

### Synchromesh units (Fig. 1)

#### Locking position

Axial motion of the coupler (A) presses the synchro brake (B) against the friction cone of the flange (C) via the balls (D) and pressure elements (E). The speed difference existing between the parts to be coupled creates a radial rotation which is limited by the pressure elements (E) which, in turn, cause the chamfered teeth on the synchro brake (B) to be pressed against the coupler (A), so opposing any relative displacement of that coupler. The pressure applied by the coupler (A) and the angular offset of the synchro brake (B) generate axial pressure between the friction cones of the synchro brake (B) and the flange (C) via the teeth chamfers. This axial pressure ensures synchronisation by gradually reducing the difference in the speed of the parts to be coupled. Once synchronisation has been achieved, the synchro brake (B) is moved rearwards under the pressure exerted by the coupler (A) until the teeth on the coupler (A) are located opposite the spaces between the teeth on the synchro brake (B). At this moment, the resistance that has, so far, opposed the movement of the coupler (A) during speed shifting is overcome and the coupler (A) can then be engaged noiselessly with the teeth on the flange (C) of the gear to be engaged. Rigid connection is established between the shaft and the gear and the speed is engaged. If two components are placed with their teeth in contact during the speed shifting phase, the chamfers provided on the tooth flanks offset the gear to be engaged until every tooth is positioned opposite a space between teeth.

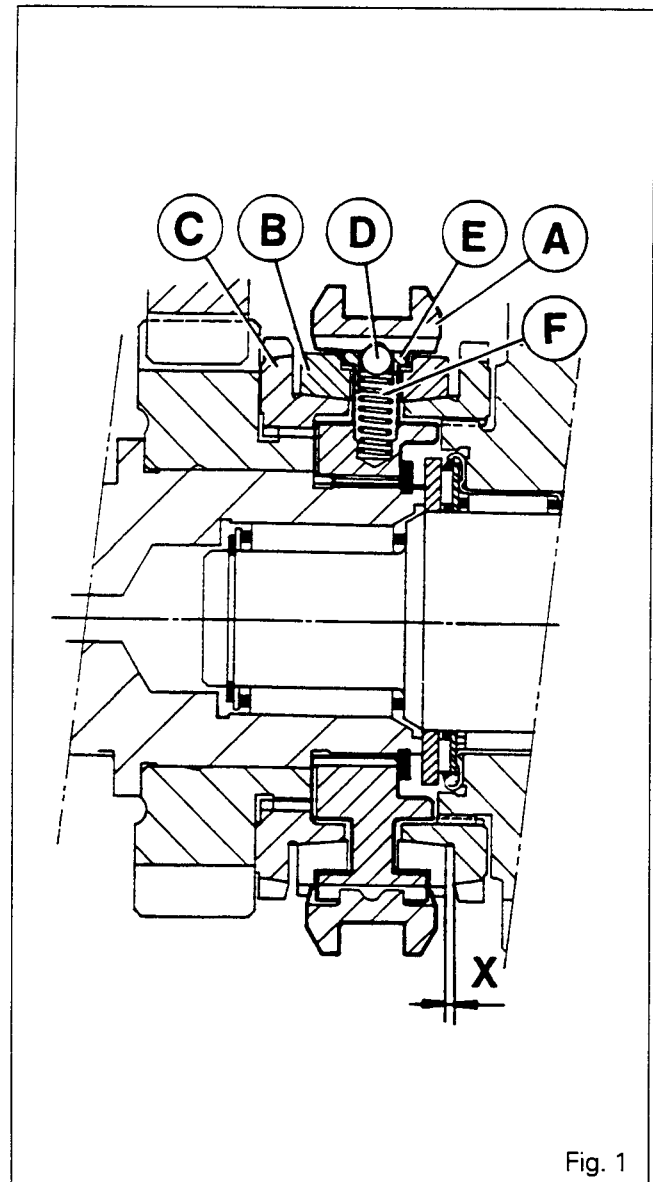

Fig. 1

#### Neutral position

The coupler (A) is located in the middle position. The balls (D) are pushed back into the V groove on the coupler (A) by the pressure springs (F). The gears are free to rotate on the shaft. In this neutral position, the coupler (A) is locked by means of three balls (D) which are held by the springs (F).

#### Overhaul

When the synchromesh units (11), (23) and (31) or the reverse shuttle are removed, the wear on the brakes (B) should be checked.

Place the flange (C) on a flat surface.

Correctly position the brake (B) by turning it through several revolutions and applying pressure on it by hand.

Using a set of feeler gauges, measure dimension X at several locations (Fig. 2). If this dimension is less than 0.8 mm, fit a new synchro brake (B), after checking the cone. When new synchro brakes are fitted, measure dimension X which must be within the following tolerances:

- 1st/2nd speed synchro (11) = 0.9 to 1.5 mm,
- 3rd/4th speed synchro (23) = 0.9 to 1.5 mm,
- Reverse shuttle (mechanically operated) = 1.4 to 2.1 mm,
- Hare/Tortoise synchro (31) = 0.9 to 1.5 mm

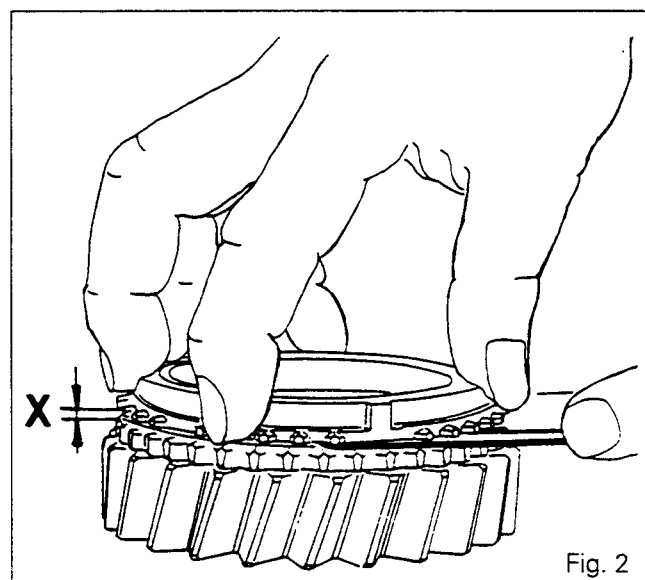

Fig. 2



# Gearbox - Transmission assembly



5A01.7

## D. Specifications: Transmission with pressure-loaded clutch

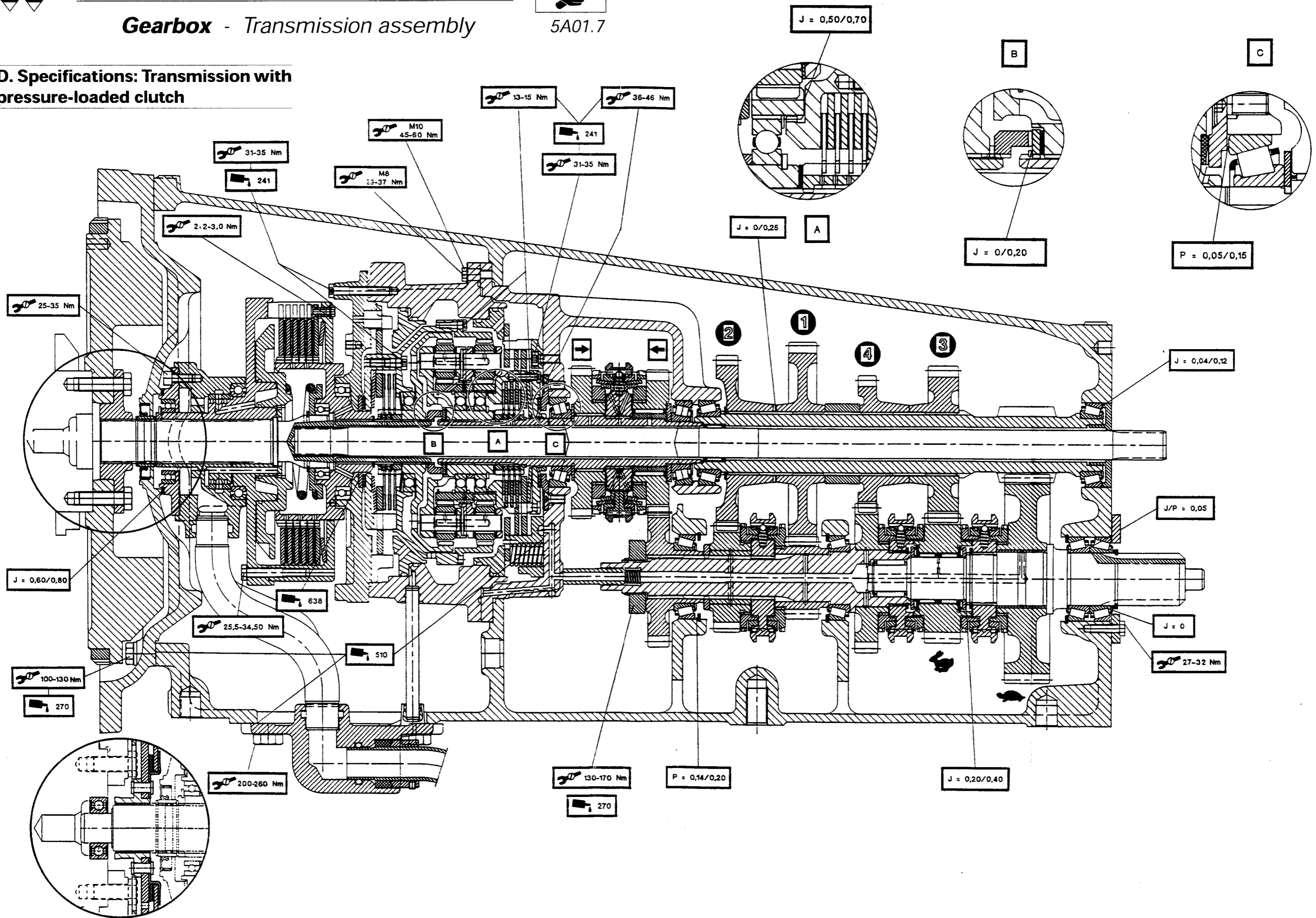



5A01.8

6100 SERIES TRACTORS

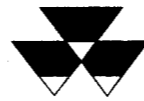

# Gearbox - Transmission assembly

## E. Specifications: Transmission with spring-loaded clutch

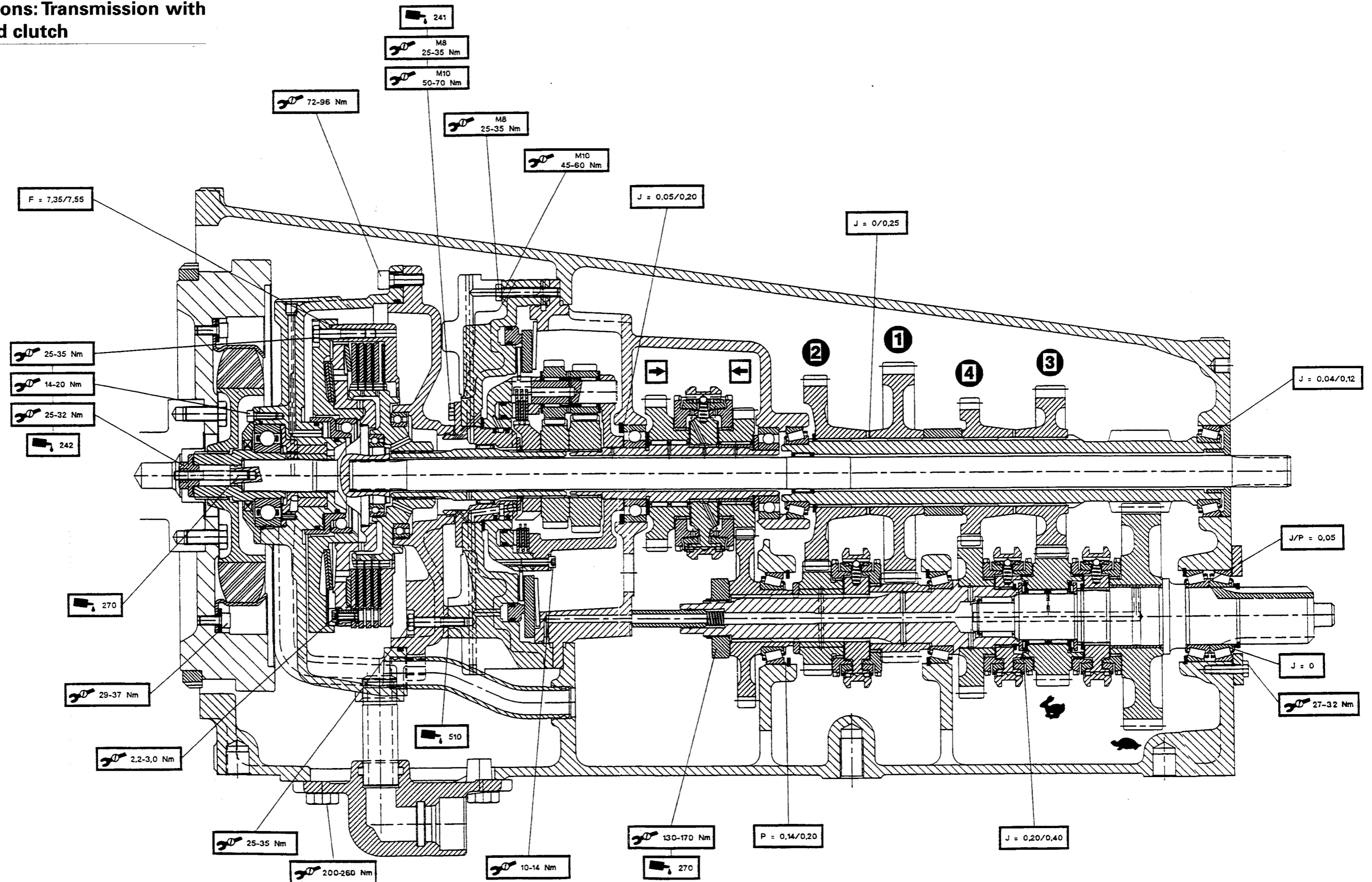





---

6100 SERIES TRACTORS

---



5A02.1

**Heavy Duty gearbox** - Transmission assembly

5A02 Main gearbox

CONTENTS

- **General** \_\_\_\_\_ **2**



5A02.2

## 6100 SERIES TRACTORS



### Heavy Duty gearbox - Transmission assembly

#### General

A heavy duty gearbox has been introduced as from the following serial numbers:

- F008020 on 6170 tractors, France,
- F008029 on 6180 tractors, France.

Subsequent introduction for other countries.

The main improvements provided by the new gearbox are reinforced gears and the introduction of dual-cone synchronisers.

The design of the heavy duty gearbox is identical to that of the main gearbox (see Section 5A01).

This gearbox can be equipped with a Dynashift or Speedshift input unit and with a standard creeper gearbox (according to option).

The operation and principle of the gears remain similar to those of the standard gearbox.

Depending on the load exerted on the Hare / Tortoise synchroniser, the splines in the synchro hub are lubricated by means of a radial bore in the output shaft.

#### List of parts

- |   |   |
|---|---|
| <ul style="list-style-type: none"> <li>(1) Bearing cone</li> <li>(2) Bearing cup</li> <li>(3) Shim(s)</li> <li>(6) Splined washers</li> <li>(7) 1st drive gear</li> <li>(8) Bush</li> <li>(11) 1st and 2nd gear dual-cone synchro</li> <li>(14) 2nd drive gear</li> <li>(16) Bearing cup</li> <li>(17) Bearing cone</li> <li>(18) 4th drive gear</li> <li>(23) 3rd and 4th gear dual-cone synchro</li> <li>(24) Needle-roller bearing</li> <li>(26) Circlip</li> <li>(27) Washer</li> <li>(28) Needle-roller bearing</li> <li>(29) 3rd drive gear (Hare)</li> <li>(30) Needle-roller bearing</li> <li>(31) Hare / Tortoise dual-cone synchro</li> <li>(32) Washer</li> <li>(35) Bush</li> </ul> | <ul style="list-style-type: none"> <li>(36) Tortoise gear</li> <li>(37) Bearing cup</li> <li>(38) Shim(s)</li> <li>(39) Bearing cone</li> <li>(40) Bearing cone</li> <li>(41) Bolt</li> <li>(42) Shim(s)</li> <li>(43) Thickness shim</li> <li>(44) Output shaft</li> <li>(45) Circlip</li> <li>(46) Lock plate</li> <li>(48) Bearing cup</li> <li>(49) Circlip</li> <li>(50) Deflector</li> <li>(51) Shim(s)</li> <li>(52) Cup</li> <li>(53) Bearing cone</li> <li>(54) Layshaft</li> <li>(55) 3rd driven gear</li> <li>(56) 4th driven gear</li> <li>(57) Spacer</li> <li>(58) Shim(s)</li> <li>(59) 2nd driven gear</li> <li>(60) 1st driven gear</li> <li>(61) Circlip</li> <li>(62) Needle-roller bearing</li> <li>(63) Bearing cone</li> <li>(64) Cup</li> <li>(65) Gearbox housing</li> <li>(66) Reverse gear housing</li> <li>(67) Input gear</li> <li>(68) Nut</li> <li>(69) Mainshaft</li> <li>(70) Retaining ring</li> <li>(71) Oil feed pipe</li> <li>(72) Spring</li> <li>(77) Washer with flats</li> <li>(78) Tab washer</li> <li>(79) Needle-roller bearing</li> <li>(80) Spacer</li> <li>(81) Needle-roller bearing</li> <li>(82) Spacer</li> </ul> |
|---|---|



6100 SERIES TRACTORS

Heavy Duty gearbox - Transmission assembly



5A02.3

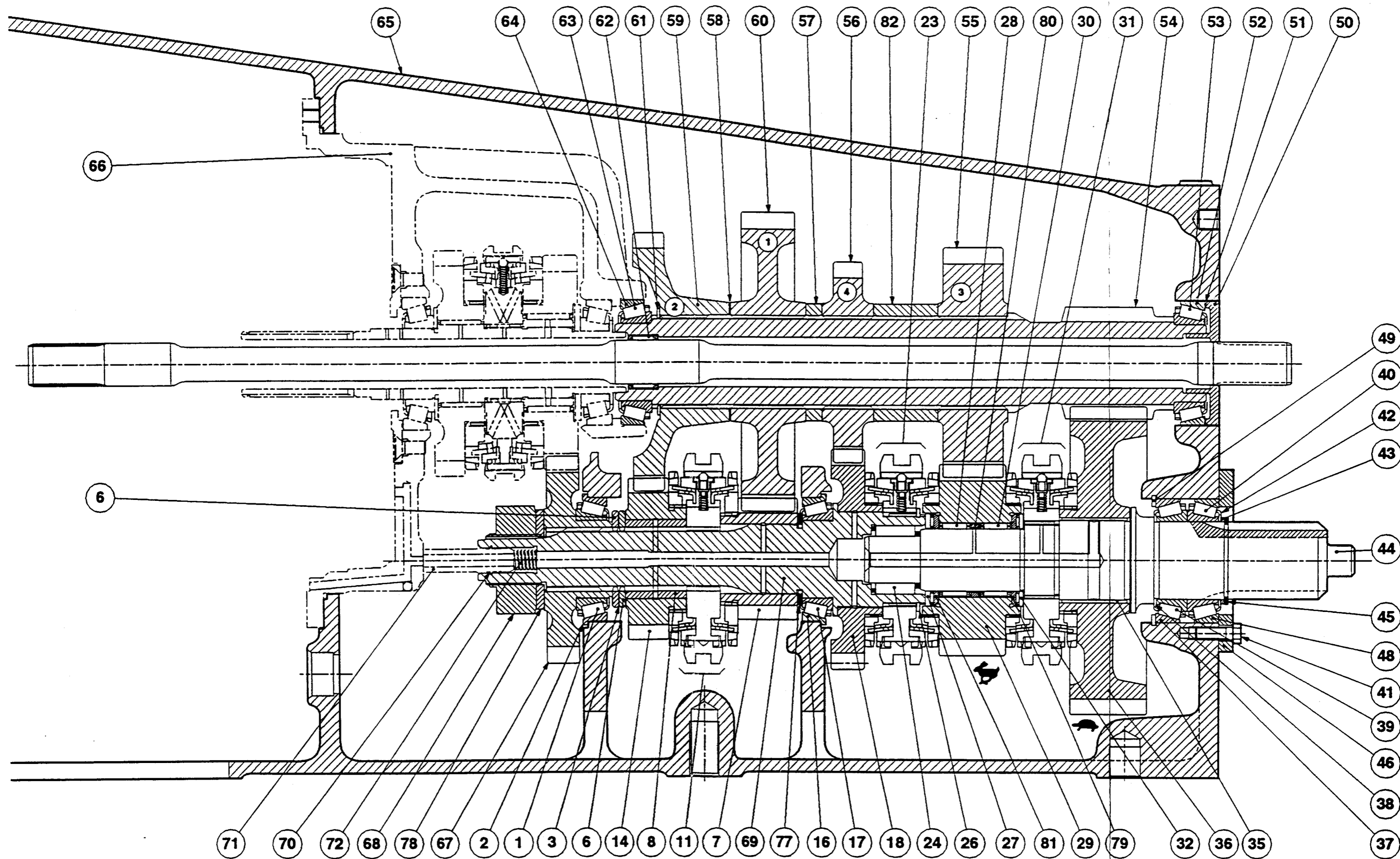



5A02.4

6100 SERIES TRACTORS



# Heavy Duty gearbox - Transmission assembly

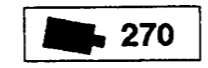
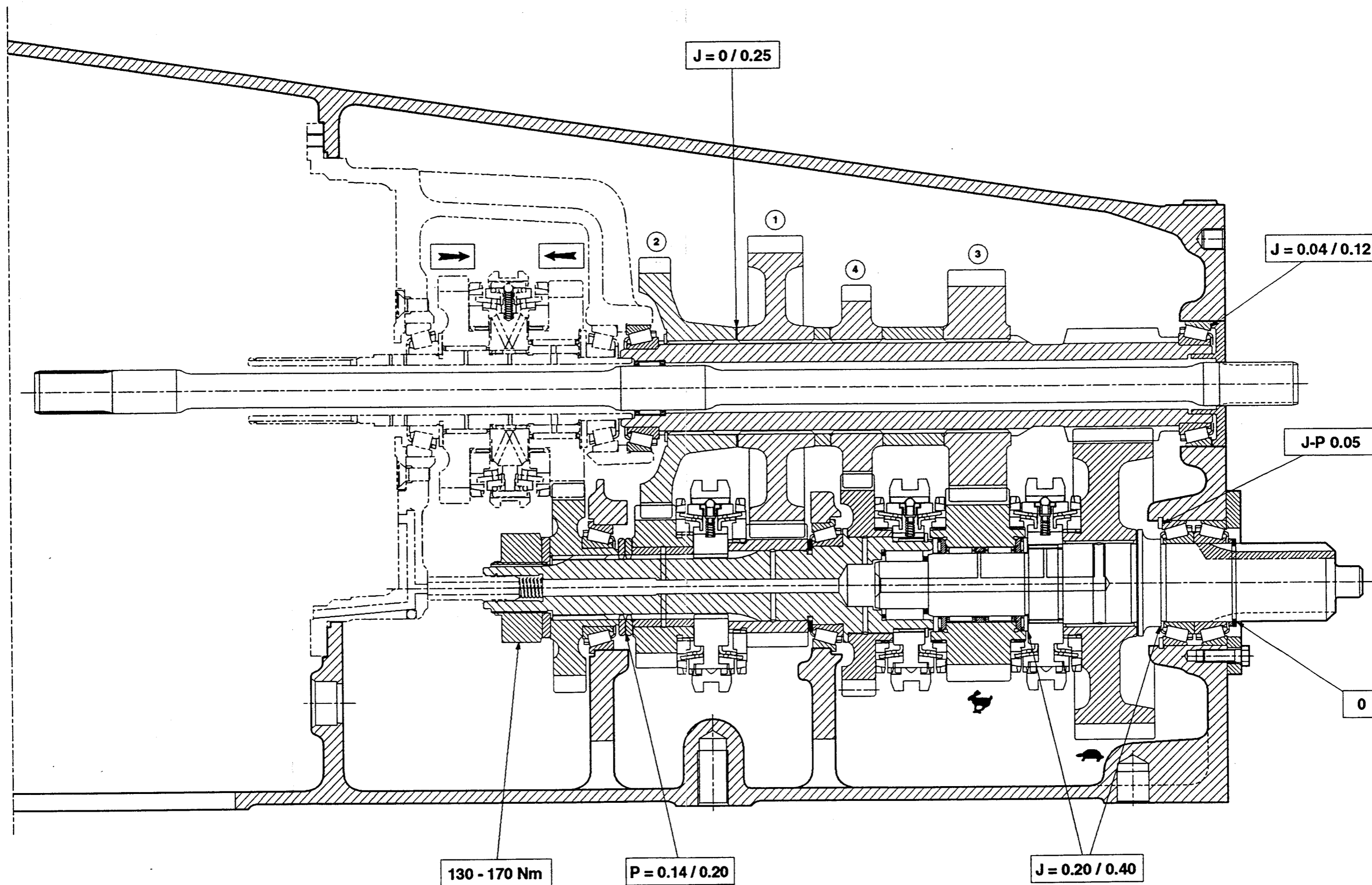

270



*5 B01 Input unit*

CONTENTS

-	<b>General</b> _____	<b>2</b>
A.	<b>Removal</b> _____	<b>2</b>
B.	<b>Refitting</b> _____	<b>3</b>
C.	<b>Service tool</b> _____	<b>3</b>
D.	<b>Speedshift version</b> _____	<b>5</b>



5B01.2

## 6100 SERIES TRACTORS

**Gearbox - Input unit****General**

The input unit is in the form of an interchangeable module fitted at the input end of the gearbox. It is made up of two completely separate parts: the Speedshift or Dynashift unit and the reverse shuttle. The input unit transmits the motion to the transmission via the wet clutch.

**The Speedshift:** This is an independent function which allows the input speed on the main unit to be doubled. It is located on the front of the input unit and comprises a hydraulic pressure-loaded clutch linked to an epicyclic reduction unit. For its operation, see Section 5 B02.

**The Dynashift:** This is an independent device which allows four ratios to be selected while running, without declutching, using a lever located under the steering wheel. The Dynashift assembly is secured to the front of the input unit. It is a hydraulically controlled gear change device providing for ratios on input to the gearbox.

This function is ensured by two epicyclic gear trains associated with two hydraulic pressure-loaded clutches. For its operation, see Section 5 B03.

**The reverse shuttle:** This is housed in the enclosure to the rear of the input gearbox and consists of a set of two gears operated via a synchromesh mechanism. A pair of idler gears allows the direction of rotation to be reversed. For its operation, see Section 5 B04.

**A. Removal**

When the input gearbox is replaced, the layshaft shimming must be adjusted.

To allow the bearings to be shimmed correctly, the gearbox must be removed from the tractor.

1. Split the tractor between the gearbox and the rear axle, see Section 2 B01.
2. Remove the selector cover, see Section 5 C01 or 5 C02 according to the version.
3. Separate the gearbox from the engine, see Section 2 A01.
4. Remove the reverse shuttle, see Section 5 B04.
5. Remove the wet clutch, see Section 4 A01 or 4 B01 according to the version, and use the type of sling suitable for the input unit (Fig. 1 or 8) with bolts "A" of the correct length. Remove the PTO shaft.
6. Remove the eight bolts (30) (Fig. 2). Do not remove the bolts (66) with a dimension of 13 mm across flats.

**Note:** Attachment of the input unit is identical on the Speedshift version.

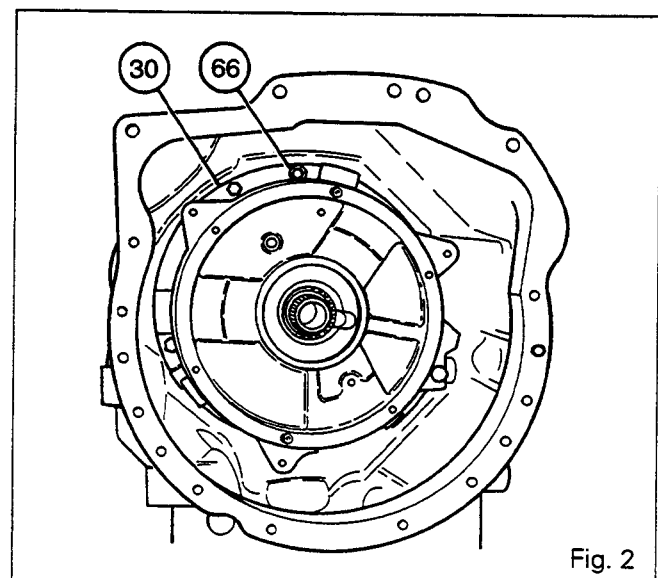
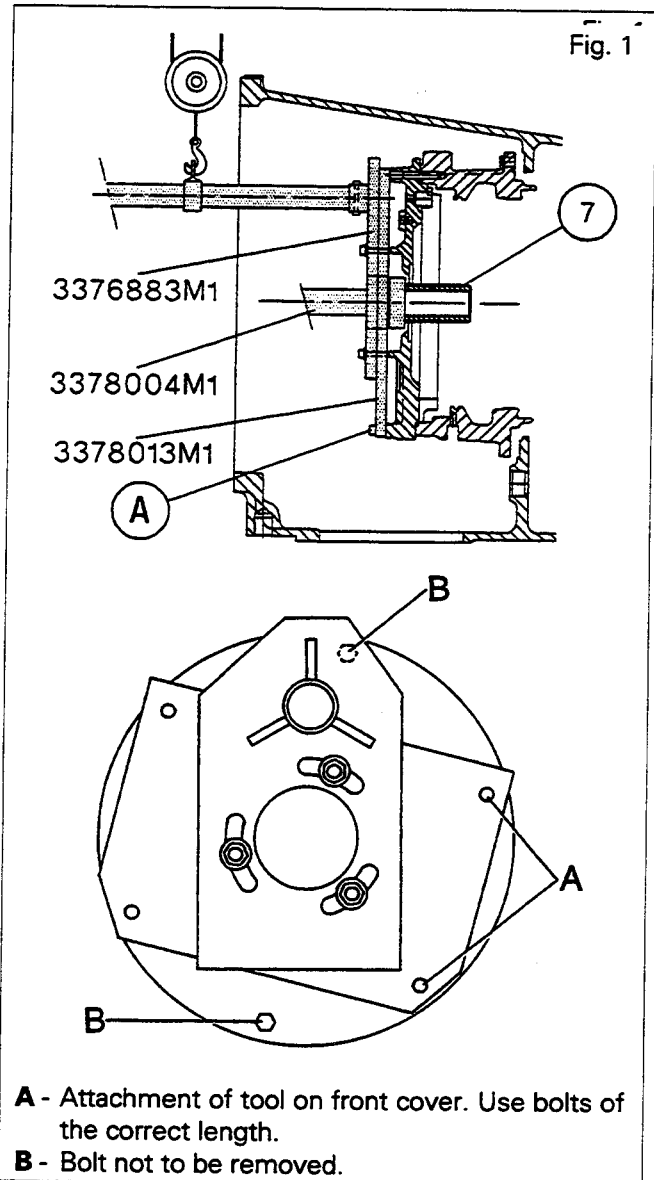

Fig. 2



## Gearbox - Input unit

7. Detach and remove the input unit, pulling it forwards.
8. Discard the O-rings **(2)** (for gearbox with spring-loaded clutch) and **(3)**. Recover the cup **(64)** and the locating pin **(4)** (Fig. 3 and 4).

### B. Refitting

9. On the input unit, check that the cup **(64)** and O-ring **(2)** (if fitted) are in position (Fig. 3).
10. On the housing, position the new O-rings **(3)** and the locating pin **(4)** (Fig. 4).
11. On the gearbox, screw in two locating studs «G», as per Fig. 4. Position the unit in the housing, using the sling.
12. At a first stage, with the help of an operator, slightly lift the layshaft through the opening of the selector cover in order to engage the cone of the shaft in the cup **(64)**.
13. Rotate the shaft **(7)** using the sleeve 3378004M1 (Figs 1 and 8) (see Part C). Position the unit with respect to the locating pin. Tighten the bolts to a torque of 45 - 60 Nm.
14. Remove the sling. Fit the four original bolts "A" (Fig. 1) after smearing them with Loctite 241, and tighten them to a torque of 25 - 35 Nm.
15. Shim the layshaft, see Section 5 F01.
16. Reinstall the wet clutch, see Sections 4 A01 or 4 B01 according to the version.
17. Fit the PTO shaft via the back of the gearbox. (See section 7E01).
18. Recouple the gearbox to the engine, see Section 2 A01.
19. Adjust the selector, see Section 5 B04.
20. Reinstall the selector cover, see Sections 5 C01 or 5 C02 according to the version.
21. Recouple the tractor between the gearbox and the rear axle, see Section 2 B01.
22. Carry out a road test on the reverse shuttle and on ratios A, B, C and D of the Dynashift or on the Speedshift high and low ranges (according to the version).

### C. Service tools

1. Tools available through MF network  
**3376883M1 - Sling for front unit (Fig. 5)**

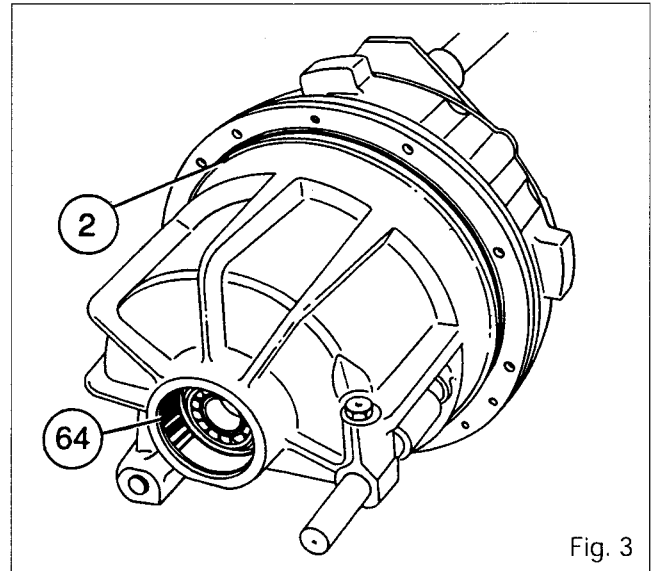

Fig. 3

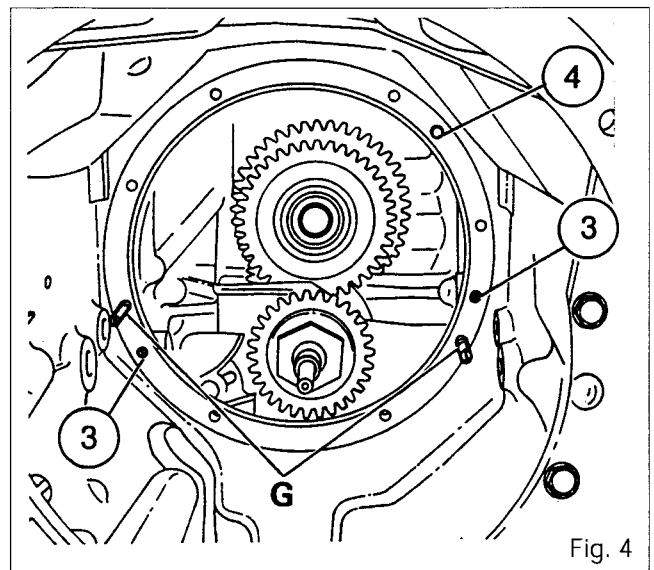

Fig. 4

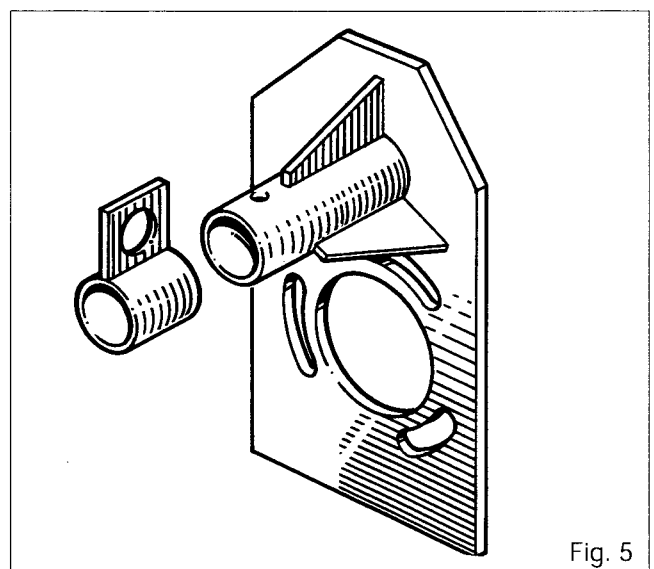

Fig. 5



5B01.4

6100 SERIES TRACTORS



**Gearbox - Input unit**

**3378004M1 - Sleeve (Fig. 6)**

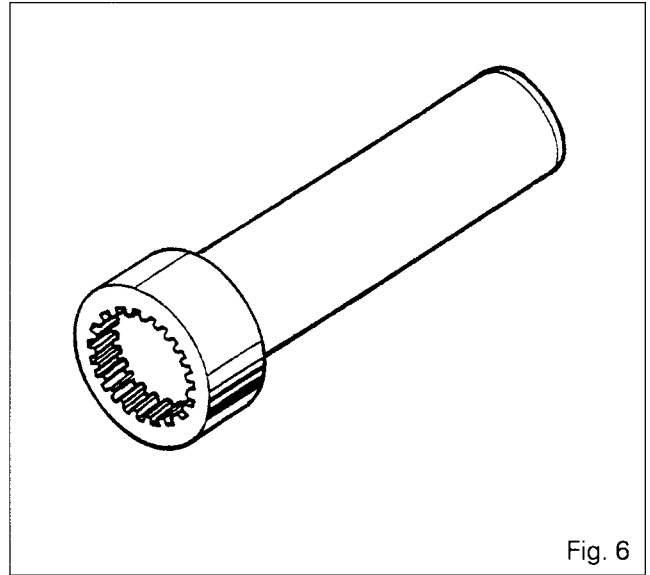

**3378013M1 - Adapter plate (Dynashift) for sling (Fig. 7)**

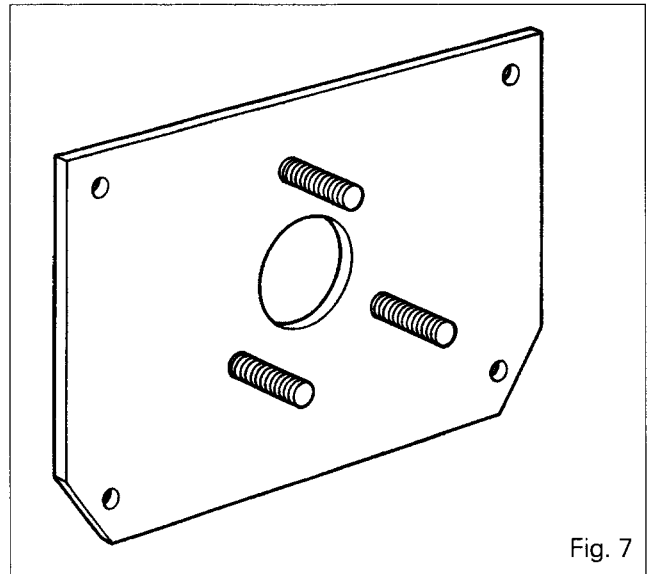

**2. Tools to be manufactured locally**  
**Handling bar**

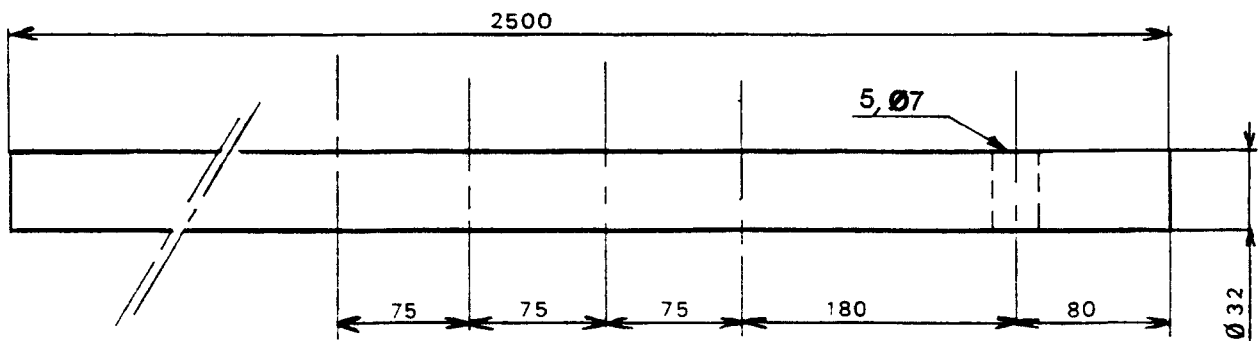





## Gearbox - Input unit

### D. Speedshift version

On Speedshift version input units, use sling 3376883M1 (Fig. 8) when removing them. The operating procedure is identical to that for the Dynashift version.

#### Special points

Before removing the unit, check that the bolts "A" (Fig. 8) are of the required length and are properly tightened.

When the sling has been removed, fit the original bolts "A" after coating them with Loctite 542.

Refit the housing supporting the clutch (see Sections 4 A01 Part H and 4 B01 Part G).

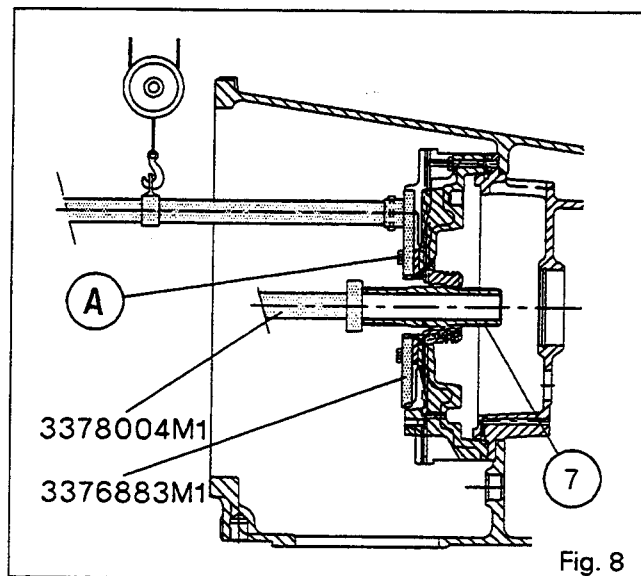





## ***Gearbox - Speedshift***

### *5 B02 Speedshift*

#### CONTENTS

-	<b>General</b> _____	2
-	<b>Operation</b> _____	2
A.	<b>Removing the front cover</b> _____	6
B.	<b>Disassembling the front cover</b> _____	6
C.	<b>Separating planetary carrier and cover assembly</b> _____	7
D.	<b>Disassembling the planetary carrier assembly</b> _____	7
E.	<b>Disassembling hydraulic cover</b> _____	7
F.	<b>Reassembling the planetary carrier</b> _____	8
G.	<b>Reassembling the hydraulic cover</b> _____	9
H.	<b>Refitting the planetary carrier assembly</b> _____	10
I.	<b>Reassembling the front cover</b> _____	10
J.	<b>Refitting the front cover</b> _____	11



## 6100 SERIES TRACTORS



5B02.2

# Gearbox - Speedshift

### General

The Speedshift unit is mounted at the front of the gearbox input. It is a hydraulically operated gearchange device which provides two different input ratios to the main gearbox. It does this by means of:

- a multidisc hydraulic clutch,
  - an epicyclic gear train consisting of a planetary carrier with three twin planetary gears, an input sun gear and an output sun gear,
  - a system for braking the planetary carrier hydraulically.
- The design of the Speedshift allows the ratios to be changed on the move, even under full load, without declutching.

### Different versions

The following versions can be obtained as a function of the number of teeth on sun gears /6\ and /7\ and the order in which they are fitted:

- 30 km/h or 40 km/h version (Fig.1)
- version with super creeper gears (Fig.2).

### Operation

#### 30 Kph and super creeper version : stepdown

#### 40 Kph version : stepup (Fig. 3)

In this mode (Fig. 3), there is no supply to the hydraulic components and the Speedshift operates as a purely mechanical transmission. Oil in chamber of pistons (28) and (48) returns to the housing via the gallery C and the solenoid. The drive from the hollow primary shaft (36) is transmitted to the input sun gear /7\ by the splines which secure the gear to the shaft. Sun gear /7\ drives the compound planetary gears /12\ which are mounted to rotate freely on spindles /8\. The planetary gears in turn drive the output sun gear /6\, which is splined to the hollow secondary shaft (5), in one of the following ratios: 30 km/h 1.26 stepdown - 40 km/h 1.26 stepup - super creeper 7.8 stepdown. Since no hydraulic pressure is applied, the planetary carrier assembly (50) is locked against rotation by a Belleville spring disc (18) which applies pressure to pressure plate (20) and thus stops disc (21) from turning, the latter being locked to the planetary carrier assembly in rotation by splines.

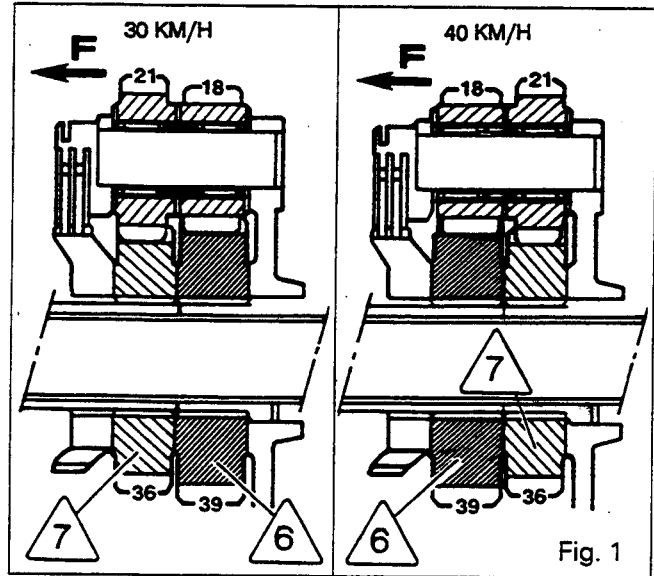

Fig. 1

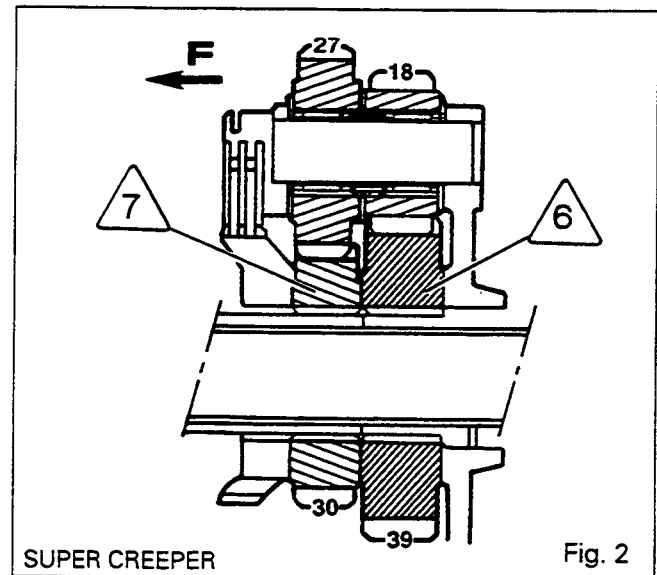

Fig. 2

### List of parts

(1) O-ring	(13) Housing	(27) Front cover	(43) Spring washer
(2) O-ring	(14) Spacer	(28) Clutch piston	(44) Pressure plate
(3) Bolt	(15) Hub	(29) O-ring	(45) Disc
(4) Bush	(16) Needle-roller bearing	/30\ Seal ring	(46) Spring washer
(5) Secondary shaft	(17) Thrust washer	/31\ Seal ring	(47) Pressure plate
/6\ Output sun gear	(18) Belleville spring disc	(32) Needle-roller bearing	(48) Piston
/7\ Input sun gear	(19) O-ring	(33) Seal carrier	(49) Bolt
/8\ Planetary gear spindles	(20) Pressure plate	(36) Primary shaft	(50) Planetary carrier assembly
/9\ Planetary carrier cover	(21) Disc	(37) Circlip	(51) O'ring
(10) Thrust washer	(22) O-ring	(38) Lug washer	
(11) Needle-roller bearing	(23) O-ring	(39) Washer	
/12\ Compound planetary gears	(24) Bolt	(40) Ball	
	/25\ Hydraulic cover	(41) Pressure plate	
	(26) O-ring	(42) Disc	



6100 SERIES TRACTORS



**Gearbox - Speedshift**

5B02.3

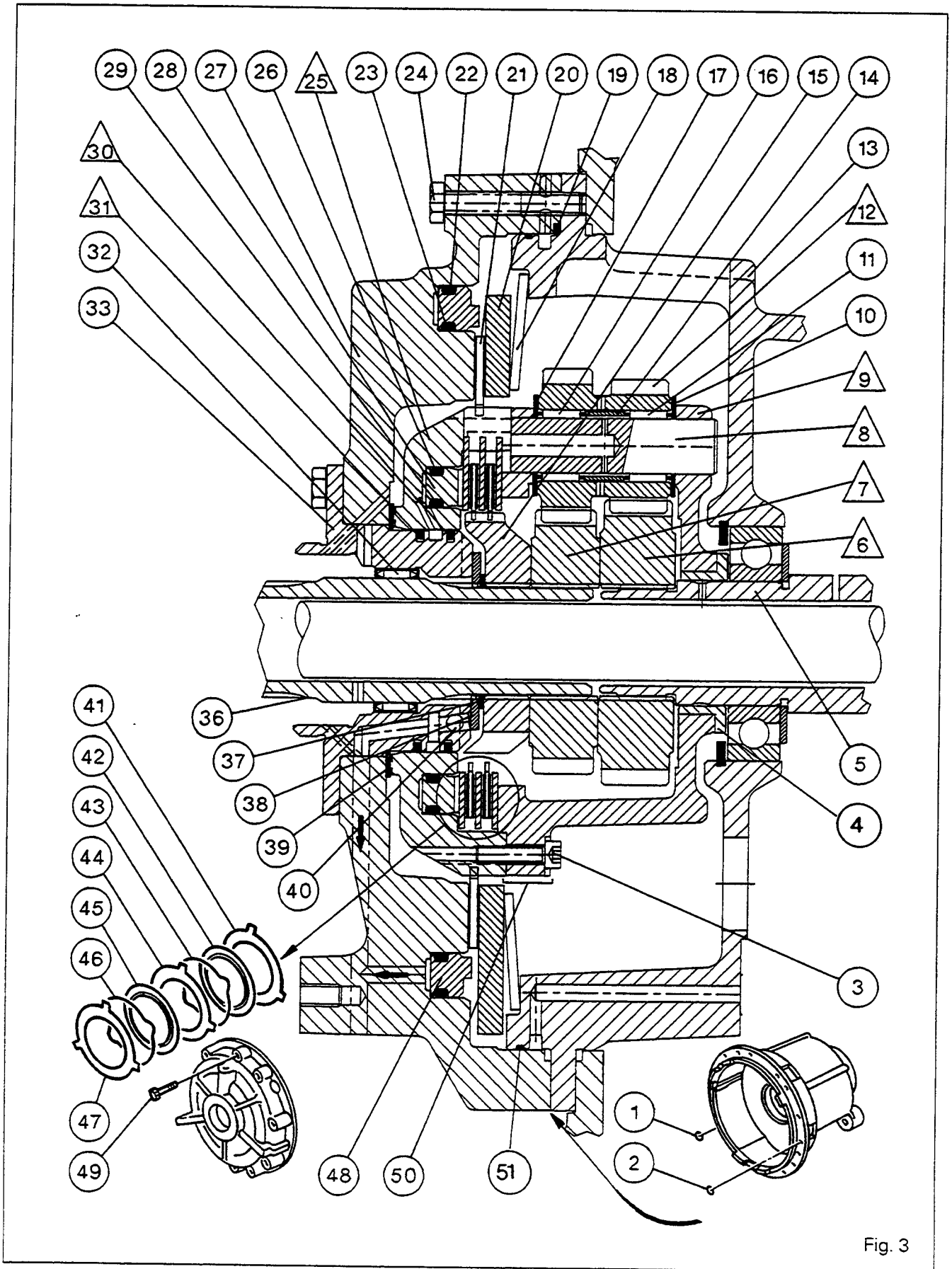

Fig. 3



5B02.4

# Gearbox - Speedshift

## Hydraulic operation : direct transmission (Fig.4)

The range is changed by actuating the solenoid valve, which then feeds hydraulic oil to the chambers behind pistons (48) and (28) simultaneously. Braking piston (48) is then applied to pressure plate (20), which compresses the Belleville spring disc (18), thus releasing disc (21) and the planetary carrier assembly (50). At the same time clutch piston (28) clamps together pressure

plates (41), (44), (47) and the discs (42), (45) which are driven by hub (15). Since the pressure plates are secured to the planetary carrier by three lugs, drive is transmitted from the primary input shaft (36) to the hub (15) and from there to the clutch assembly which transmits it to the planetary carrier (50). The primary shaft (36) and the planetary gear and sun gear assembly turn at the same speed as the secondary shaft (5) thus giving direct transmission in the ratio of 1/1.

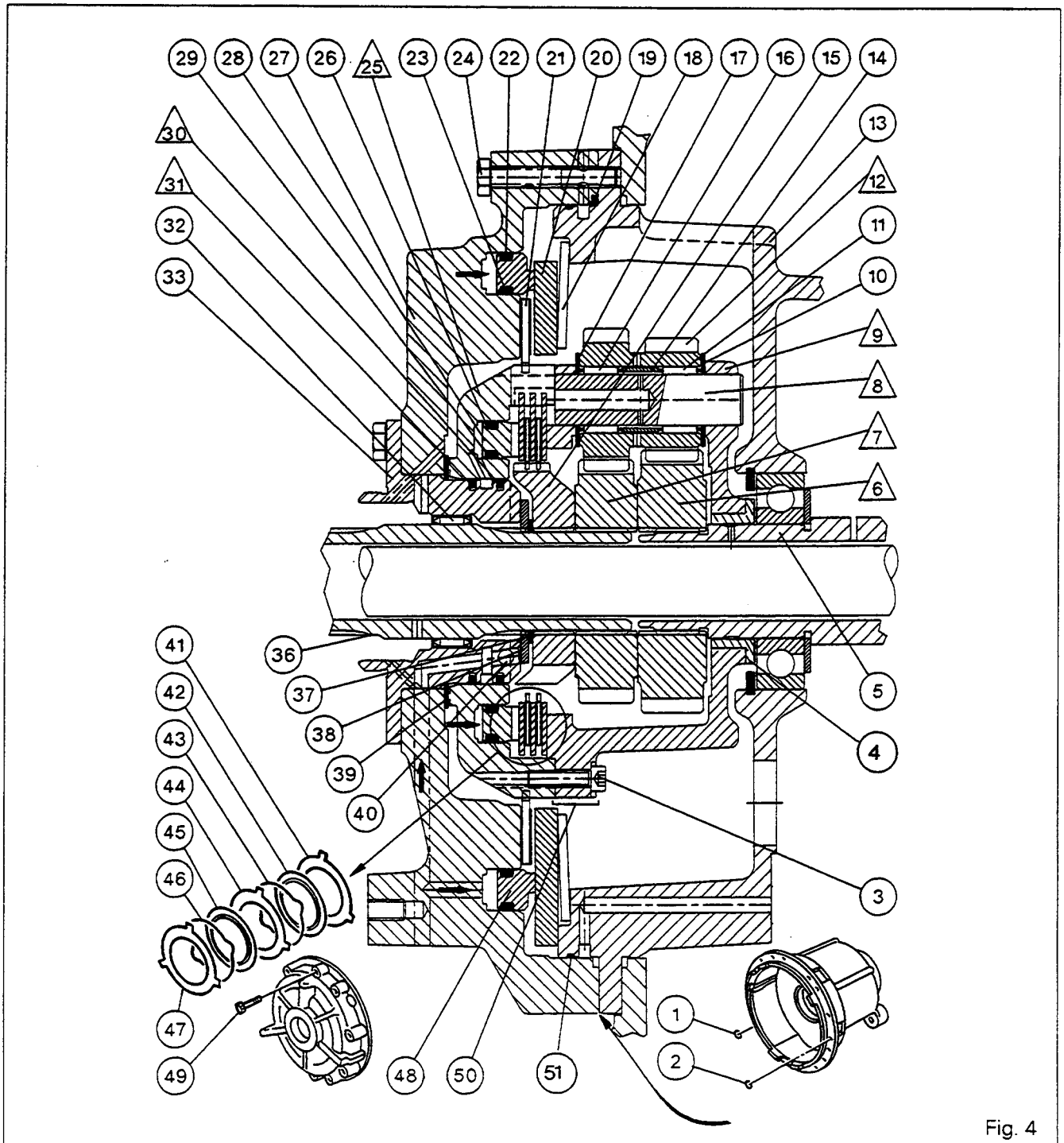
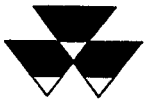

Fig. 4



# Gearbox - Speedshift

5B02.5

Exploded view

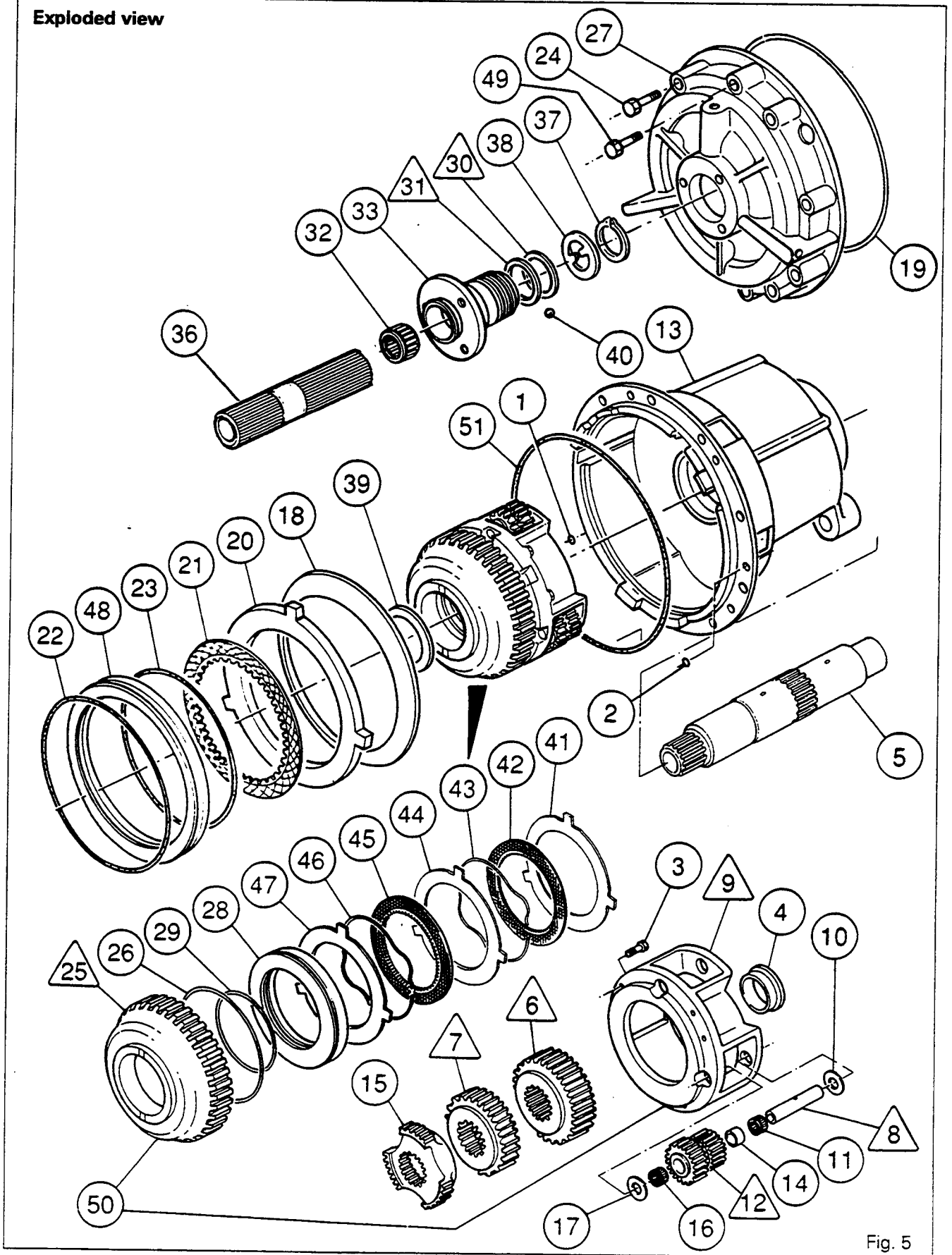

Fig. 5



### A. Removing the front cover

1. Split the tractor between the engine and gearbox (section 2 A01).
2. Remove the wet clutch, see section 4 A01 or 4 B01 according to version.
3. Remove the case supporting the clutch.
4. Unscrew bolts (24) (Fig.6).
5. Screw two pilot pins into the gearbox housing in diametrically opposed positions (Fig.6).
6. Unscrew the three bolts (49) a little at a time, taking them in order (Fig.6).
7. Remove cover (27) together with shaft (36) (Fig.6). Discard O-rings (1) and (2), (19).
8. Take out disc (21), pressure plate (20), Belleville spring disc (18) and planetary carrier assembly (50).

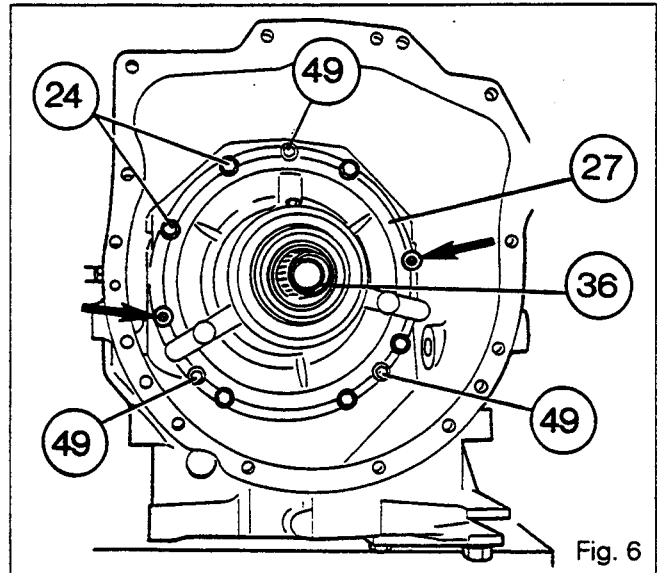

Fig. 6

### B. Disassembling the front cover

9. Extract circlip (37) and take out lug washer (38).
10. Withdraw shaft (36) from the front of the cover.
11. Remove washer (39).
12. Withdraw piston (48) from the cover (Fig.7).
13. Remove seals (22) and (23) and discard them.
14. Remove seal rings /30\ and /31\ (discard these rings).
15. Take out needle-roller bearing (32) and discard it.
16. Drive ring carrier (33) out of cover (27) (Fig.8) (Work from the rear of the ring carrier using a plastic-faced mallet as a drift).

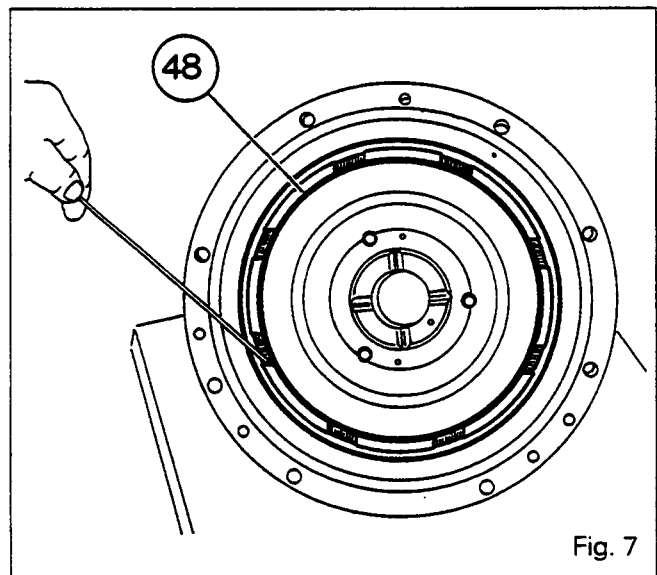

Fig. 7

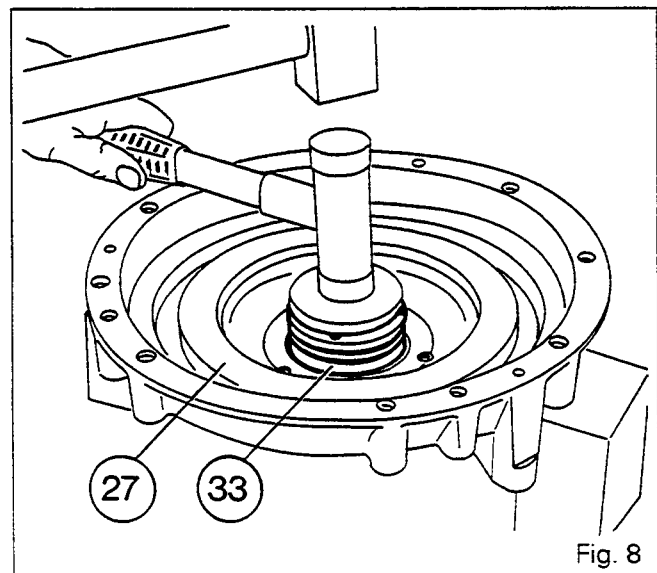

Fig. 8





## Gearbox - Speedshift

5B02.7

### C. Separating planetary carrier and cover assembly.

17. Place the planetary carrier assembly (50) down on a bench (with the planetary carrier cover /9\ on top).
18. Unscrew bolts (3).
19. Separate planetary carrier cover /9\ from hydraulic cover /25\ while holding sun gears /6\ and /7\ in position in planetary carrier cover (Fig.9).

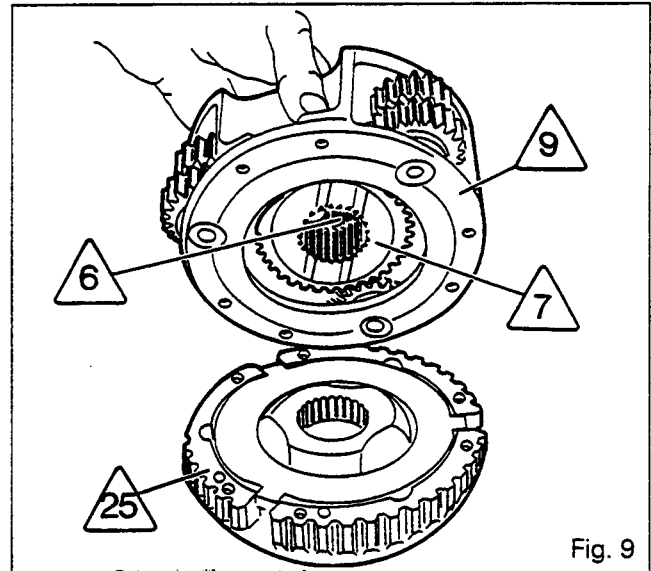

Fig. 9

### D. Disassembling planetary carrier assembly

20. Take out the 1st sun gear :
  - /7\ 36 tooth in 30 km/h version (Fig.1)
  - /6\ 30 tooth in 40 km/h version (Fig.1)
  - /7\ 30 tooth in super creeper version (Fig.2)

**N.B. : Mark the direction in which the lubricating grooves in the sun gear should face when the gear is refitted.**
21. Drive out spindles /8\ with a drift and a mallet (Fig.10).
22. Take out the planetary gears /12\.
23. Take out needle-roller bearings (11) and (16), spacers (14), and washers (10) and (17).
24. Take out the second sun gear :
  - /6\ 39 tooth in 30 km/h version (Fig.1)
  - /7\ 36 tooth in 40 km/h version (Fig.1)
  - /6\ 39 tooth in super creeper version (Fig.2)

**N.B. : Bush (4) is a force fit in planetary carrier cover /9\.**

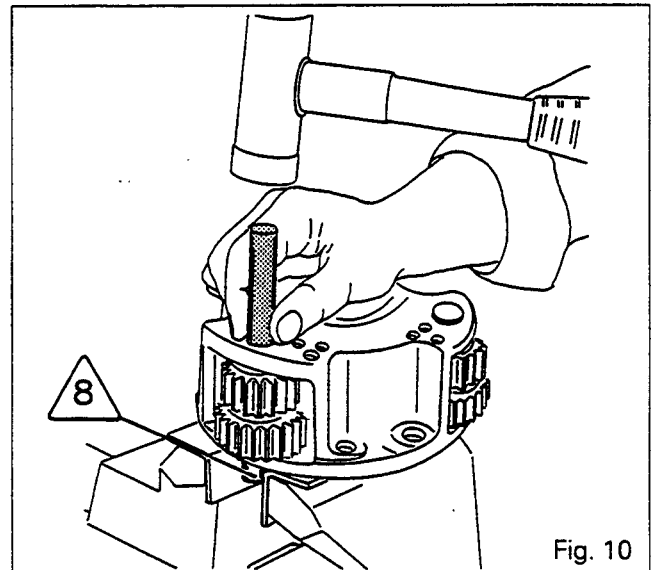

Fig. 10

### E. Disassembling the hydraulic cover

25. Take out splined hub (15).
  26. Take out pressure plate (41), disc (42), spring washer (43), pressure plate (44), disc (45), spring washer (46) and pressure plate (47).
  27. Withdraw piston (28) from cover /25\ (Fig.11).
  28. Remove O-rings (26) and (29) and discard them.
- N.B. : In the super creeper version, cover /25\ and piston (28) differ from those in the 30 and 40 km/h versions. The cross-sectional area of the piston is greater and this means that the diametric cutouts in the cover are larger.**

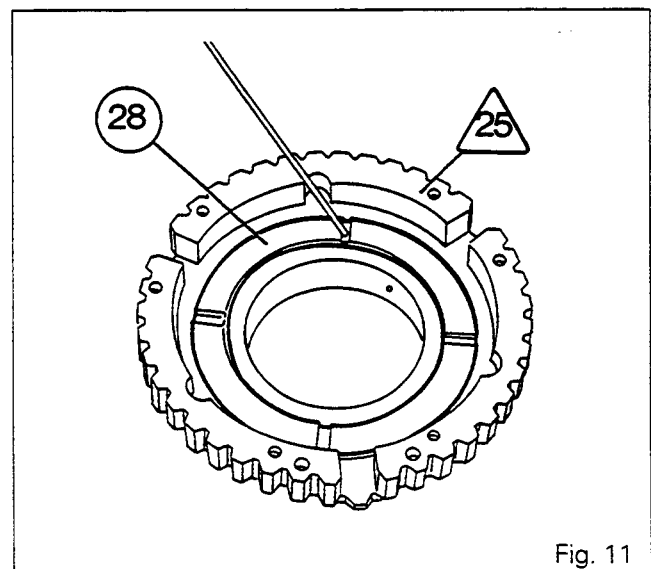

Fig. 11



5B02.8

## Gearbox - Speedshift

### F . Reassembling the planetary carrier

29. Clean and check the parts and replace any which are faulty.

30. Lubricate the needle-roller bearings.

31. Check that the oilways in spindles /8\ are not blocked.

#### 30 km/h version

32. Fit the 39 tooth sun gear /6\ into the planetary carrier cover (Fig.12).

#### 40 km/h version

33. Fit the 36 tooth sun gear /7\ into the planetary carrier cover (Fig.12).

#### Super creeper version

34. Fit the 39 tooth sun gear /6\ into the planetary carrier cover (Fig.12).

**N.B. : In all versions, fit the gear so that the lubricating grooves in it are facing towards face F of the planetary carrier cover (Fig.12).**

35. Fit a needle-roller bearing (11), a spacer (14) and a needle-roller bearing (16) into a planetary gear /12\.

36. Fit an assembled planetary gear into the cover, with the following gears closer to face F in the respective cases (Fig.13) :

- 21 tooth : 30 km/h version

- 18 tooth : 40 km/h version

- 27 tooth : super creeper version.

**N.B. : The planetary gear is marked with three punch marks made in a single face. Each punch mark indicates two teeth which line up.**

**In the case of the 40 km/h version, mark the unpunched face with three paint lines in the same positions as the punch marks made in the factory.**

37. Fit washers (10) and (17).

38. Line up the planetary gear and washers with a locating rod made up locally : diameter = 16 mm, length = 80 mm (Fig.13).

39. Insert spindle /8\ into the unobstructed bore in face F and drive it home with a mallet until it is slightly recessed below the face (Fig.14).

**N.B. : The oilway opening onto the circumference of spindle /8\ must face outwards.**

**The oilway opening onto the endface of spindle /8\ must face towards face F of the planetary carrier cover (Fig.13).**

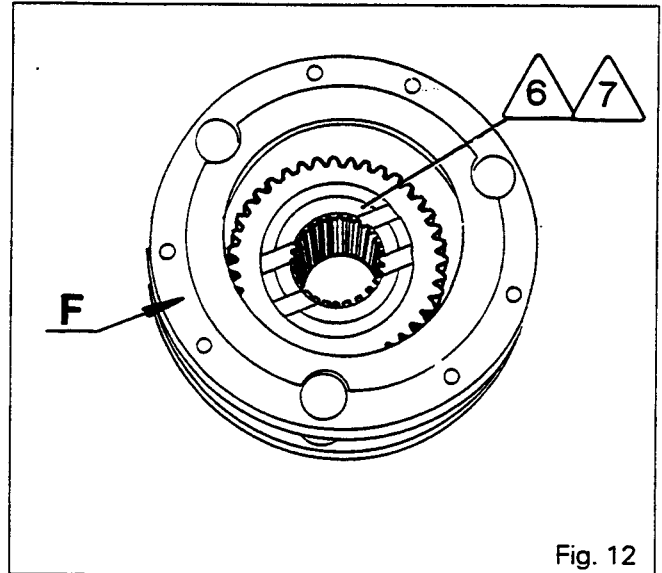

Fig. 12

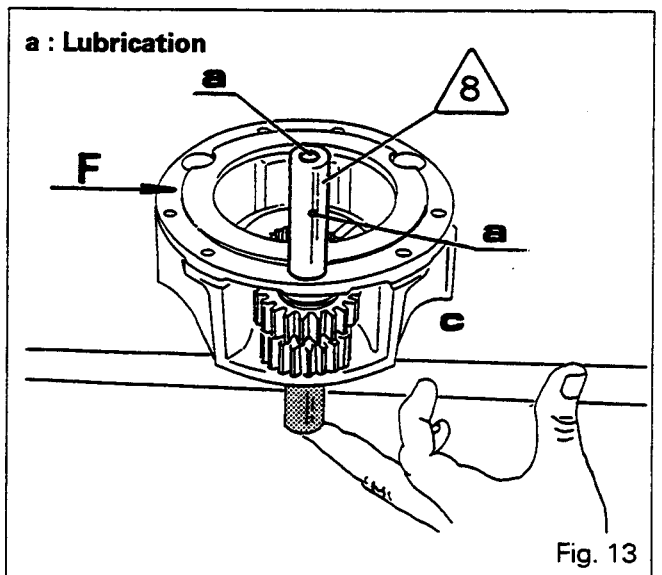

Fig. 13

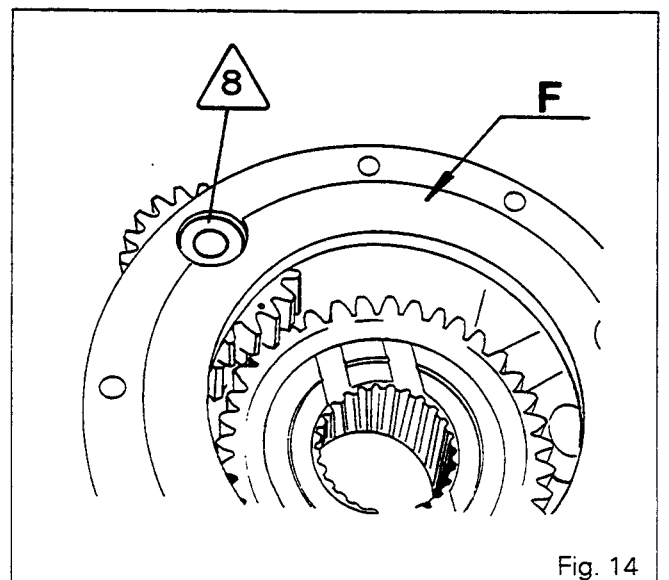

Fig. 14



## Gearbox - Speedshift

40. Repeat procedures 35 to 39 to fit the other two planetary gears.

**N.B.:** The marks (punch marks) on the three planetary gears must line up with the centre on line spaced  $120^\circ$  apart, as shown in Fig. 15.

Once fitting of the spindles /8\ has been completed, re-check that the marks on the planetary gears line up as above.

If the marks do not line up properly, this will cause damage to the Speedshift.

41. Fit the following sun gears in the respective versions :

- /7\ 36 tooth: 30 km/h version (Fig.1)
- /6\ 39 tooth: 40 km/h version (Fig.1)
- /7\ 30 tooth: super creeper version (Fig.2)

**N.B. :** In all versions, fit the gear so that the lubricating grooves in it are facing towards face F of the cover.

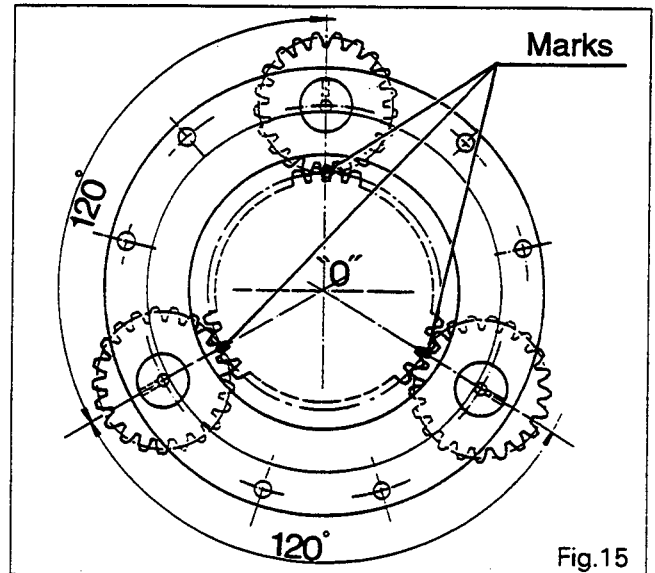

Fig. 15

### G. Reassembling the hydraulic cover

42. Clean and check the parts and replace any which are faulty.
43. Make sure that the three openings into the 17 bar passage in the hydraulic cover /25\ are not blocked (Fig. 16).
44. Lubricate O-rings (26) and (29) and fit them to piston (28).
45. Lubricate the faces against which the piston seals bear in the hydraulic cover.
46. Place the piston in the cover with the grooves facing towards the operator.
47. Tap the piston (28) gradually home into the cover by working progressively round its face with a plastic-faced mallet (Fig. 17).
48. Refit the splined hub (15) making sure it is correctly orientated.
49. Refit pressure plate (47), spring washer (46), disc (45), pressure plate (44), spring washer (43), disc (42) and pressure plate (41).

**N.B. :** Place the gaps in spring washers (43) and (46) in diametrically opposed positions.

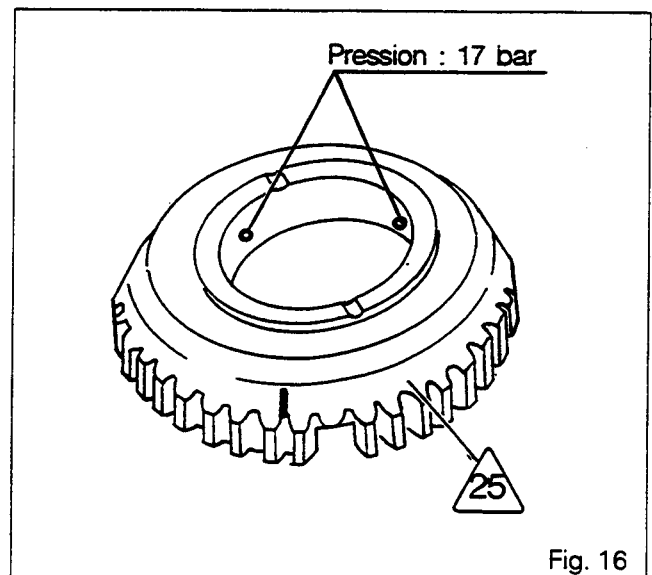

Fig. 16

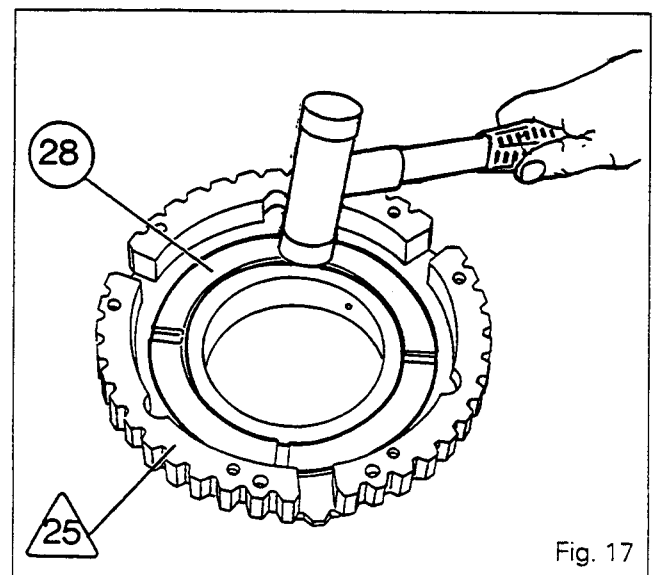

Fig. 17



## H. Reassembling the planetary carrier assembly

50. Screw two pilot pins into the hydraulic cover /25\ in diametrically opposed positions.
51. Fit the planetary carrier cover /9\ to the hydraulic cover /25\, while holding the sun gears /6\ and /7\ in position.  
**N.B. : Position the two covers so that the balancing marks (milled grooves or paint lines) are as far away from each other as possible (Fig. 18).**
52. Refit bolts (3). Bolts must be tightened to a torque of 10 - 14 Nm.
53. Tap spindles /8\ in with a pin punch so that they butt against the hydraulic cover /25\.
54. Check :
  - that discs (42) and (45) are not compressed
  - that planetary gears /12\ and sun gears /6\ and /7\ can turn freely.
55. Fit planetary carrier assembly (50) to shaft (5).
56. Fit Belleville spring disc (18).
57. Fit pressure plate (20) into housing (13).  
**N.B. : Apply three spots of grease ("Amber Technical" or equivalent) to the lugs on the pressure plate.**
58. Engage friction disc (21) onto the planetary carrier assembly.

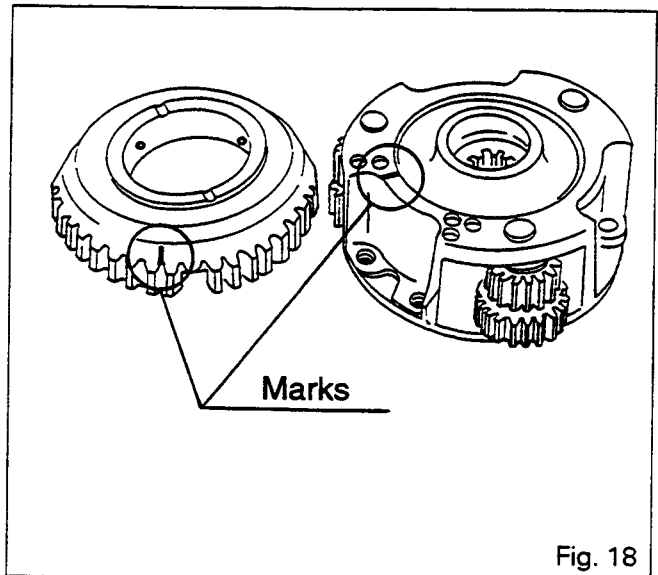

Fig. 18

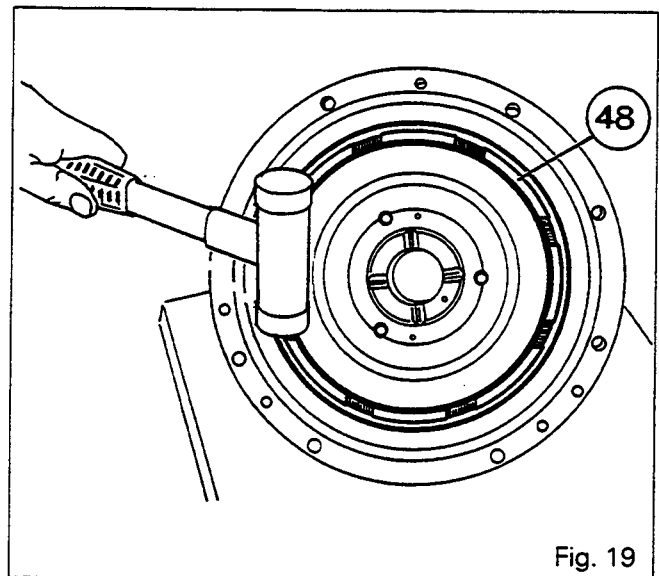

Fig. 19

## I. Reassembling the front cover

59. Clean the mating face and the rest of the cover. Make sure that the 17 bar passage and the lubricating passage are not blocked.
60. Fit seals (22) and (23) to piston (48).
61. Lubricate the surfaces in the Speedshift cover against which the piston seals bear.
62. Position the piston on the cover with its grooves facing towards the operator.
63. Tap piston (48) gradually home into the cover by working progressively round its face with a plastic-faced mallet (Fig. 19).  
**N.B. : Once the piston is fitted, check that no pieces have been detached from the O-rings.**



## Gearbox - Speedshift

5B02.11

64. Clean the ring carrier and its mating face.  
**N.B. : Ball (40) is crimped into the ring carrier.**
65. Apply a gasketing compound (Loctite Masterjoint 510 or equivalent) to the mating face of the cover.
66. Screw two pilot pins (1) into the cover. Engage the ring carrier in the cover bore (Fig.20).  
**N.B. : Check that the openings of the 17 bar passage and the lubricating passage in the ring carrier match up with the passages in the cover.**
67. Tap the ring carrier home in the cover (Fig.20).
68. Lubricate shaft (36) and insert it in ring carrier (33) from the front.  
**N.B. : Make sure that the lubricating passages in the shaft are not blocked.**
69. Refit washer (38) and circlip (37).
70. Refit rings /30\ and /31\ and make sure that they turn freely in the grooves.
71. Having made this check, remove the rings, preform them by reducing them to approximately 1/3 of their original diameter, and coat them with miscible grease (Amber Technical or equivalent) to ensure that they will be held in position effectively when the front cover is being refitted.
72. Fit the rings into their respective grooves, making sure that :  
 - they do not project from the circumference of the ring carrier,  
 - their ends are correctly overlapped (Fig.24).  
**N.B. : Even the slightest damage to the rings may give rise to leaks followed by pressure dropping in operation.**
73. Grease washer (39) and fit it into cover (27).
74. Fit new O-rings (1) and (2), (19).
75. Check that the locating pin is present in the reversing mechanism housing and that the two pilot pins are fitted.

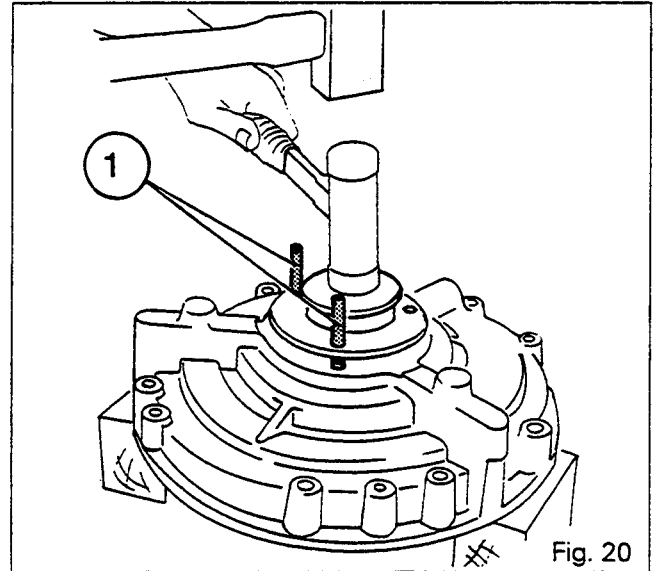

Fig. 20

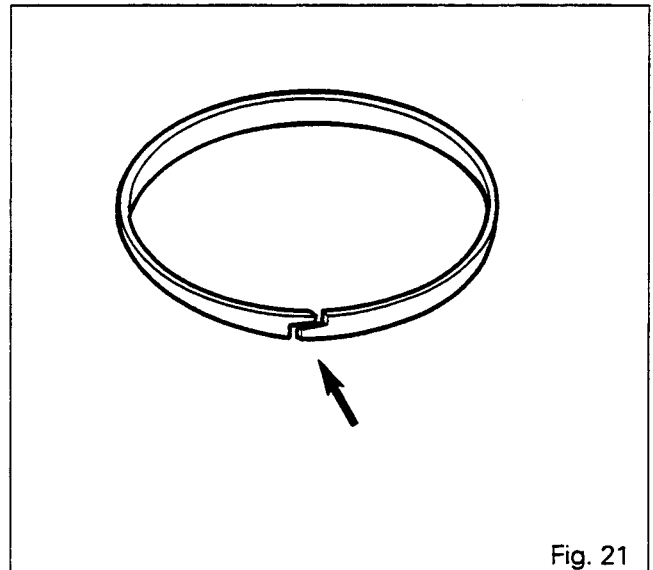

Fig. 21

78. Fit bolts (49) and tighten them to a torque of 25 - 35 Nm. Refit the housing, support and the clutch, see section 4 A01 or 4 B01 according to version.
79. Re-unite the tractor between engine and gearbox (section 2 A01).
80. Bleed the clutch or the control valve (see section 4 A01 or 4 B01 according to version).
81. Carry out a road test on the Speedshift control.

### J. Refitting the front cover

76. Fit front cover (27) together with shaft (36).  
**N.B. : Check that the 17 bar and lubricating passages in the cover match up with the openings in the housing.**
77. Refit bolts (24) and tighten them to a torque of 45 - 60 Nm.





## **Gearbox - Dynashift**

### *5 B03 Dynashift unit*

#### CONTENTS

-	<b>General</b> _____	2
-	<b>Theoretical operation</b> _____	2
A.	<b>Preliminary operations</b> _____	8
B.	<b>Removing and disassembling the cover, housing, front clutch and brake</b> _____	8
C.	<b>Removing and separating the planetary carrier assembly</b> _____	8
D.	<b>Disassembling the rear clutch and brake</b> _____	9
E.	<b>Assembling planetary carriers</b> _____	9
F.	<b>Reassembling the rear clutch and brake</b> _____	9
G.	<b>Reassembling the cover, front clutch, brake and housing</b> _____	10
H.	<b>Shimming planetary carriers</b> _____	12
I.	<b>Assembling and refitting the input unit</b> _____	13
J.	<b>Service tools</b> _____	14



5B03.2

## 6100 SERIES TRACTORS



# Gearbox - Dynashift

### General

The Dynashift assembly is mounted at the front of the gearbox input unit. It is a hydraulically operated gear change device which provides four different input ratios to the gearbox.

This function is ensured by means of two epicyclic gear trains and two pressure-loaded clutches.

The design of the Dynashift allows the four ratios to be selected on the move, without declutching, using a lever located under the steering wheel.

The Dynashift unit is controlled by two solenoid valves installed on the low-flow hydraulic system. The two solenoid valves are controlled by the tractor's Autotronic system.

### Theoretical operation

The Dynashift input unit comprises two epicyclic gear trains:

- the primary epicyclic gear train, which is the main component of the input unit, used to transmit drive from the engine to the gearbox,
- the secondary epicyclic gear train which controls the speed of the primary sun gear.

#### Primary epicyclic gear train

Drive is input via the primary ring gear (31) which is splined onto the primary shaft (7). The primary ring gear rotates at the same speed as the engine.

Drive is output via the planetary carrier (28) which is splined onto the secondary shaft (53). The primary sun gear (64) is driven by the secondary epicyclic gear train. The speed of this sun gear determines the speed reduction ratio of the unit.

#### Secondary epicyclic gear train

This epicyclic gear train is controlled by pressure-loaded clutches and brakes.

The secondary ring gear (34) is:

- either locked on the primary shaft (7) by the three clutch driving plates (3) and the Belleville washer (4) located in the front section of the unit,
- or immobilised with respect to the unit by three brake discs (15) and a piston (22).

When there is no pressure, the piston (22) is pushed rearwards by the 12 springs (20) and the Belleville washer (4) via the backing plate (16).

When the pressure of the 17-bar system is exerted on the piston (22), it is moved forwards, locking the brake discs (15) and pushing the backing plate (16) which compresses the Belleville washer (4).

The speed of the secondary ring gear is established as follows:

- Speed equal to the engine speed when the front piston is not under pressure,
- Stationary when the front piston is under pressure.

The secondary sun gear (61) is:

- either locked on the secondary shaft by the four clutch driving plates (50) and a Belleville washer (52) located on the rear section of the unit, or
- immobilised with respect to the unit by the three brake discs (41) and a piston (37).

Without pressure, the piston (37) is pushed forwards by the Belleville washer and the six springs (65).

Under the effect of the 17-bar pressure, the piston (37) moves rearwards and locks the brake discs (41). It compresses the Belleville washer (52) by means of a backing plate (45) which frees the clutch plates on the secondary shaft.

The speed of the secondary planetary carrier (39) is modified by immobilising the secondary ring gear (34) or the secondary sun gear (61). The secondary planetary carrier drives the primary sun gear (64), which defines the speed reduction ratio of the unit.

### Service tools

#### Tools available through the MF network (see Part J)

- 3376883M1 - Sling for front unit
- 3376887M1 - Centring tool
- 3376888M1 - Secondary ring gear holding tool
- 3376889M1 - Sling for shaft and cover assembly
- 3376920M1 - Planetary carrier compression tool
- 3378004M1 - Sleeve
- 3378013M1 - Adapter plate

#### Tool to be manufactured locally

- Handling bar





# Gearbox - Dynashift



5B03.3

### List of parts (Fig. 1)

- (1) Secondary ring gear carrier
- (2) Clutch driven plates
- (3) Clutch driving plates
- /4\ Belleville washer
- (5) Splined hub
- (7) Primary shaft
- (10) Friction washer
- (13) Front cover
- (14) Clutch housing
- (15) Front brake discs
- (16) Backing plate (clutch - brake)
- (17) Pressure plate
- (18) Bolt
- (19) O-ring
- (20) Springs
- (21) Spacer housing
- (22) Front piston
- (23) Blanking plug
- (24) O-ring
- (25) Bolt
- (26) O-ring
- (27) Ball bearing
- (28) Primary planetary carrier
- (29) Blanking plug
- (30) Screw
- (31) Primary ring gear
- (32) O-ring
- (33) Bolt
- (34) Secondary ring gear
- (35) O-ring
- (36) O-ring
- (37) Rear piston
- (38) Pressure plate
- (39) Secondary planetary carrier
- (40) Reverse shuttle housing
- (41) Rear brake disc
- /42\ Secondary brake housing
- (43) Bolt
- (44) Pressure plate
- (45) Backing plate (clutch - brake)
- (46) Bolt
- (47) Cover
- (48) Driven plate
- (49) Retaining ring

- (50) Rear clutch driving plate
- (51) Thrust washer
- /52\ Belleville washer
- (53) Secondary shaft
- (54) Splined hub
- (55) Circlip
- (56) Spacer
- (57) Ball bearing
- (58) Ball bearing
- (59) Rear clutch housing
- (60) Retaining ring
- (61) Secondary sun gear
- (62) Retaining ring
- (63) Needles
- (64) Primary sun gear
- (65) Springs
- (66) Bolt
- (67) O-ring
- (68) O-ring
- (69) Circlip
- (70) Stop
- [71] Shim(s)
- (72) Retaining ring
- (73) O-ring
- (74) Plug
- (75) Oil deflector
- (76) Tab washer
- (77) Spring washer
- (78) Ball

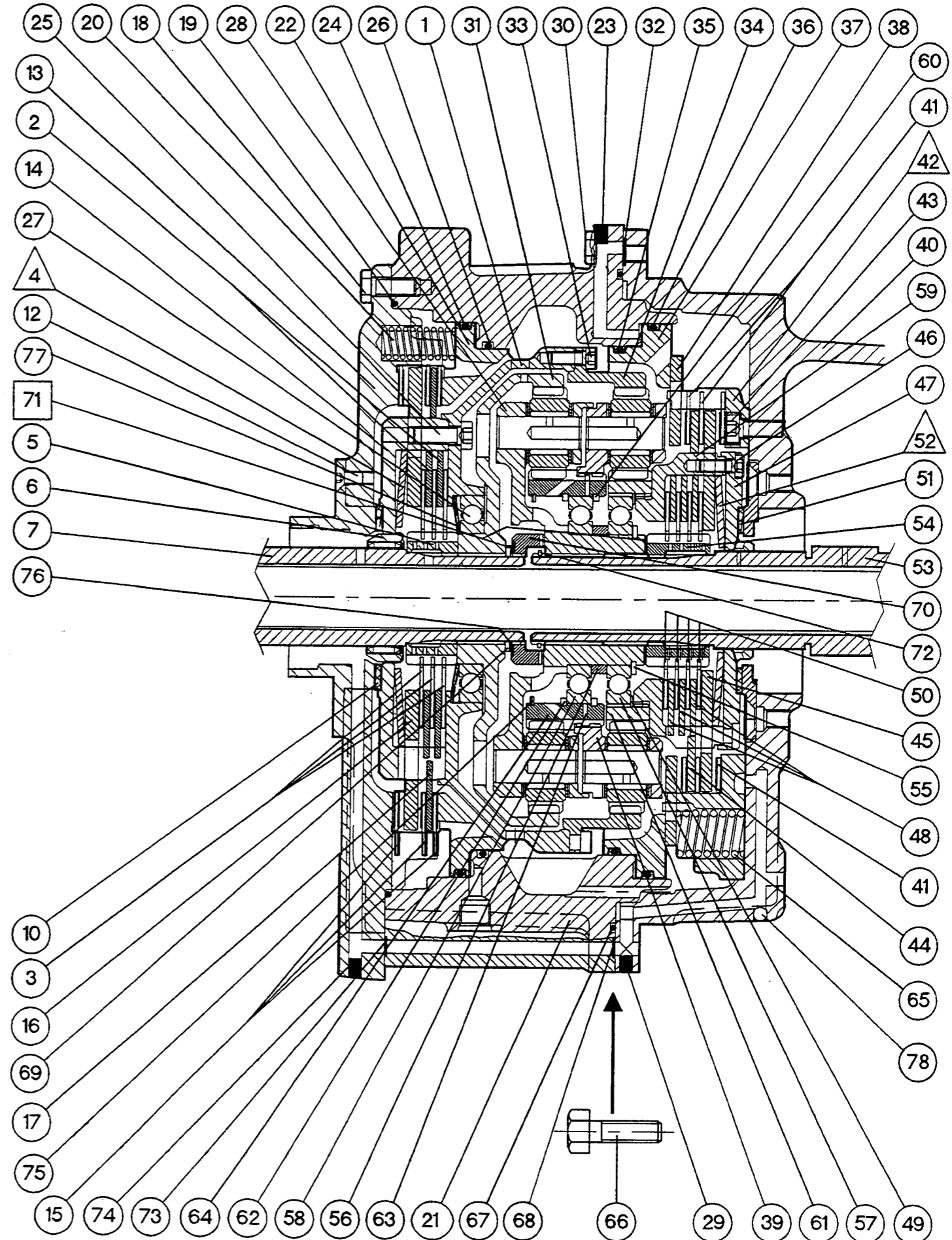



5B03.4

6100 SERIES TRACTORS



## Gearbox - Dynashift

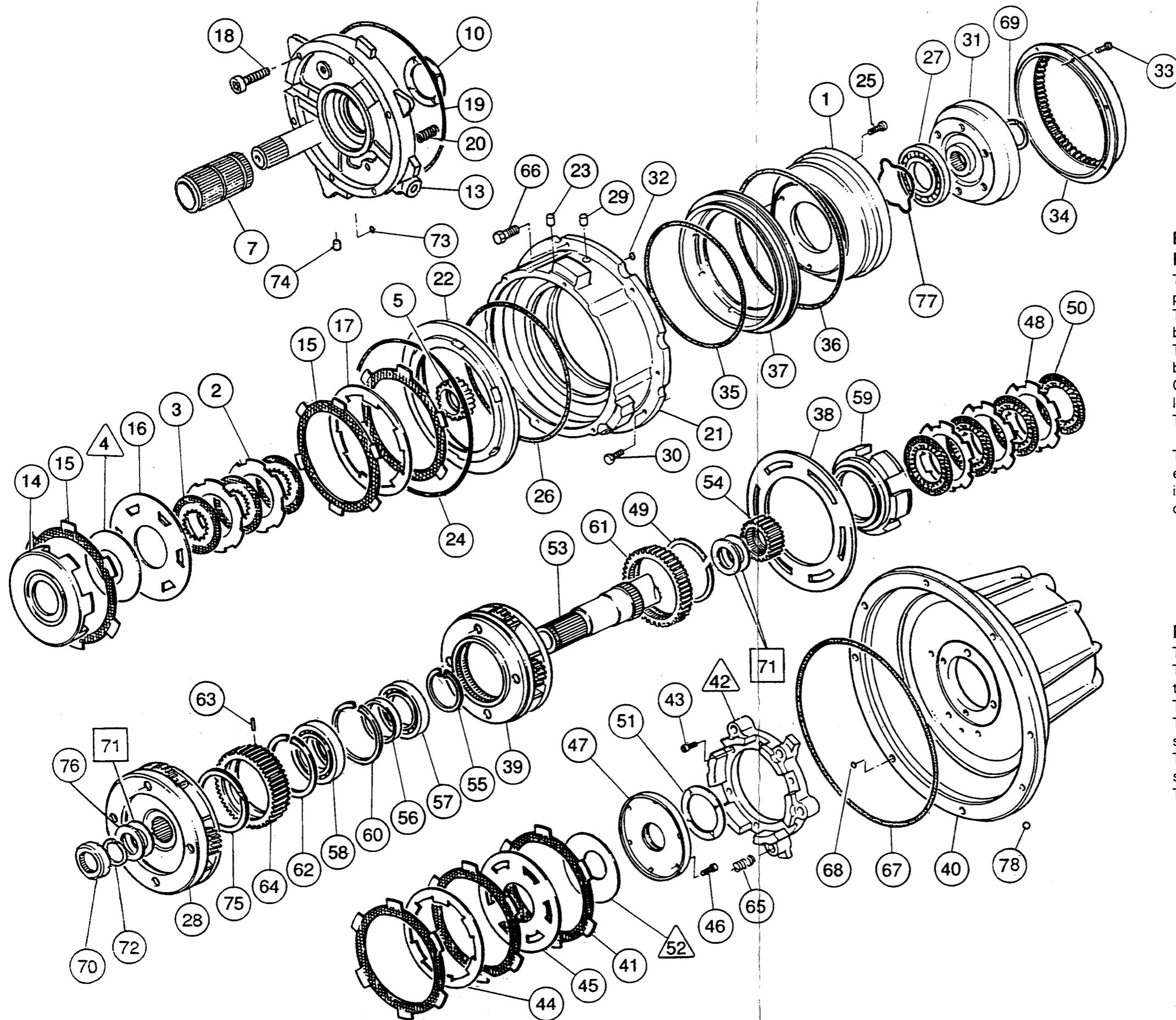

## Explanation of speed ratio

**Ratio A: Reduction 1/1.620 (Fig. 3)**

The two pistons (22) and (37) are simultaneously pressurised by the 17-bar system.

The secondary ring gear (34) is locked onto the housing by the front brake.

The secondary sun gear (61) is locked onto the housing by the rear brake.

Consequently, the secondary epicyclic gear train is locked.

The primary sun gear (64) is locked.

The speed reduction ratio is determined by the primary epicyclic gear train only. This is a classic linkage: drive is input via the ring gear and output via the planetary carrier, with the sun gear remaining motionless.

**Ratio B: Reduction 1/1.386 (Fig. 4)**

The front piston (22) is under pressure.

The secondary ring gear (34) is locked on the housing by the front brake.

The rear piston (37) is not under pressure.

The secondary sun gear (61) rotates with the secondary shaft (53) (clutch clamped).

The secondary planetary carrier (39) rotates at a slow speed, driving the primary sun gear (64).

The speed reduction ratio is thus lower.



**Gearbox - Dynashift**

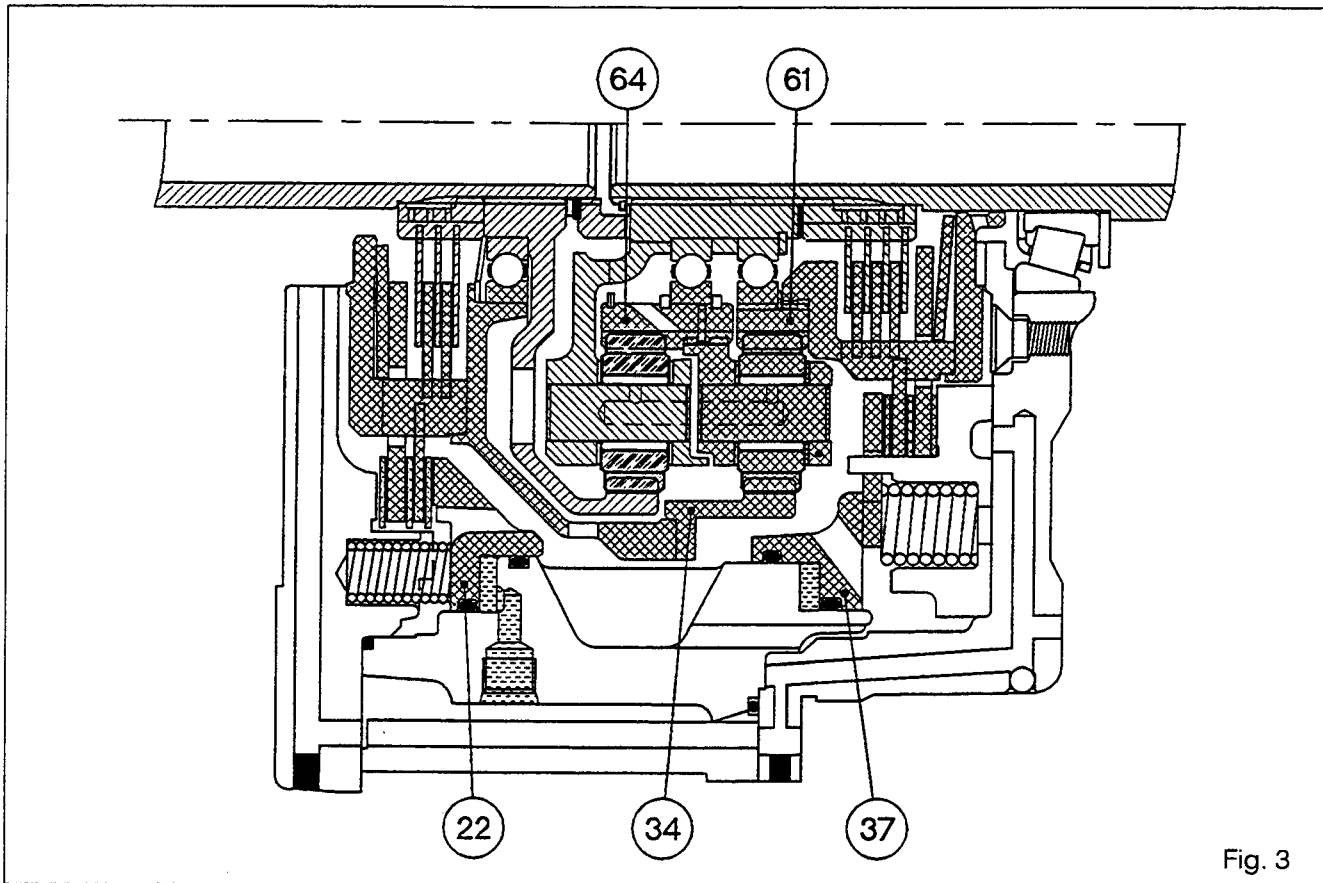

Fig. 3

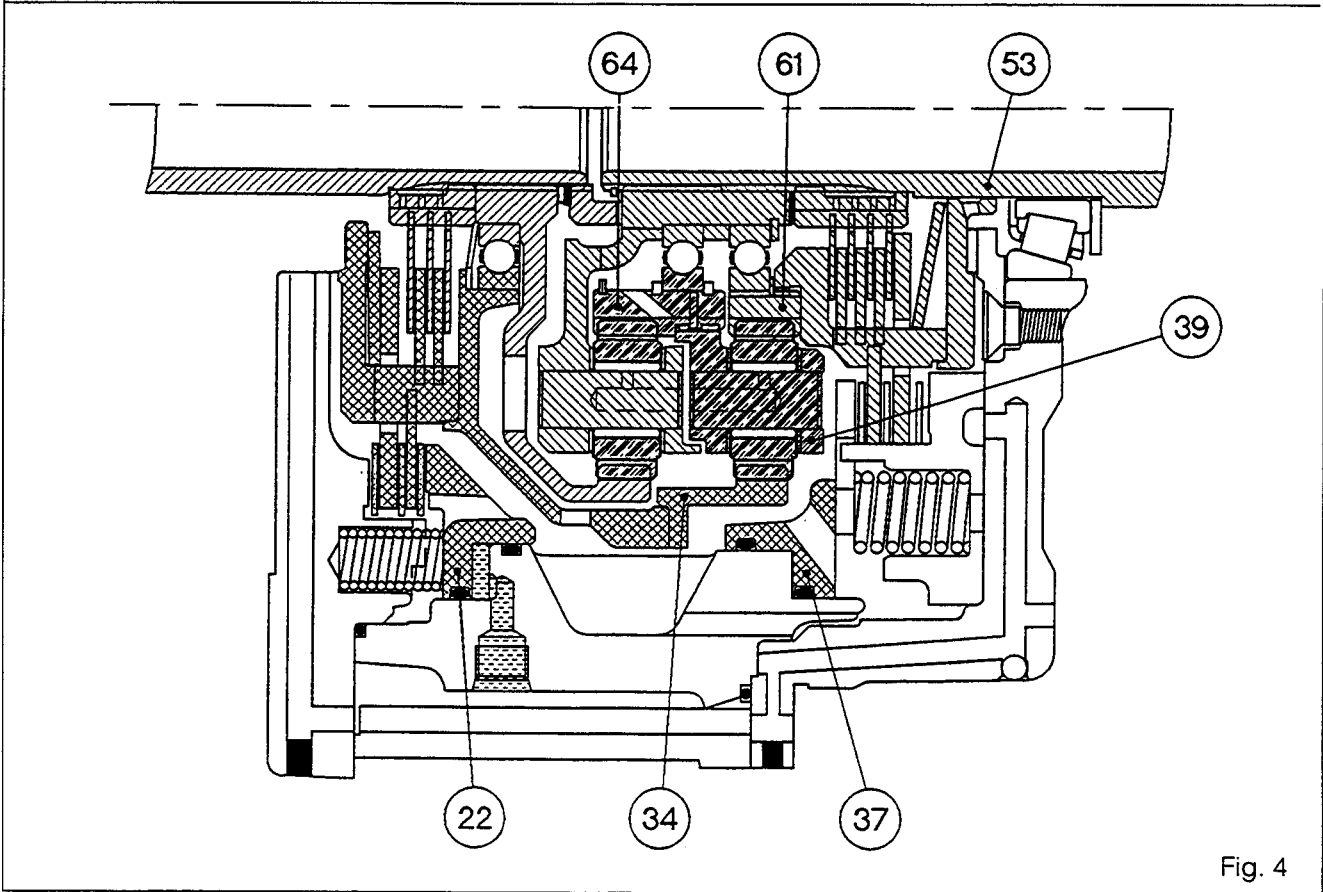

Fig. 4



5B03.6

---

**6100 SERIES TRACTORS**

---

**Gearbox - Dynashift****Ratio C: Reduction 1/1.1704 (Fig. 5)**

The rear piston **(37)** is under pressure.

The secondary sun gear **(61)** is locked on the housing by the rear brake.

The front piston **(22)** is not under pressure.

The secondary ring gear **(34)** rotates with the primary shaft **(7)** so that the secondary planetary carrier **(39)** rotates at higher speed.

The primary sun gear **(64)** is driven by the secondary planetary carrier **(39)** at a greater speed than in ratio B. The speed reduction is thus lower.

**Ratio D: Ratio 1/1 (Fig. 6)**

Neither of the pistons is under pressure. Both clutches are thus clamped.

The secondary ring gear **(34)** rotates with the primary shaft **(7)**.

The secondary sun gear **(61)** is locked on the secondary shaft **(53)**, so that the whole system is mechanically locked.

The ratio is therefore 1:1 (direct drive).



**Gearbox - Dynashift**

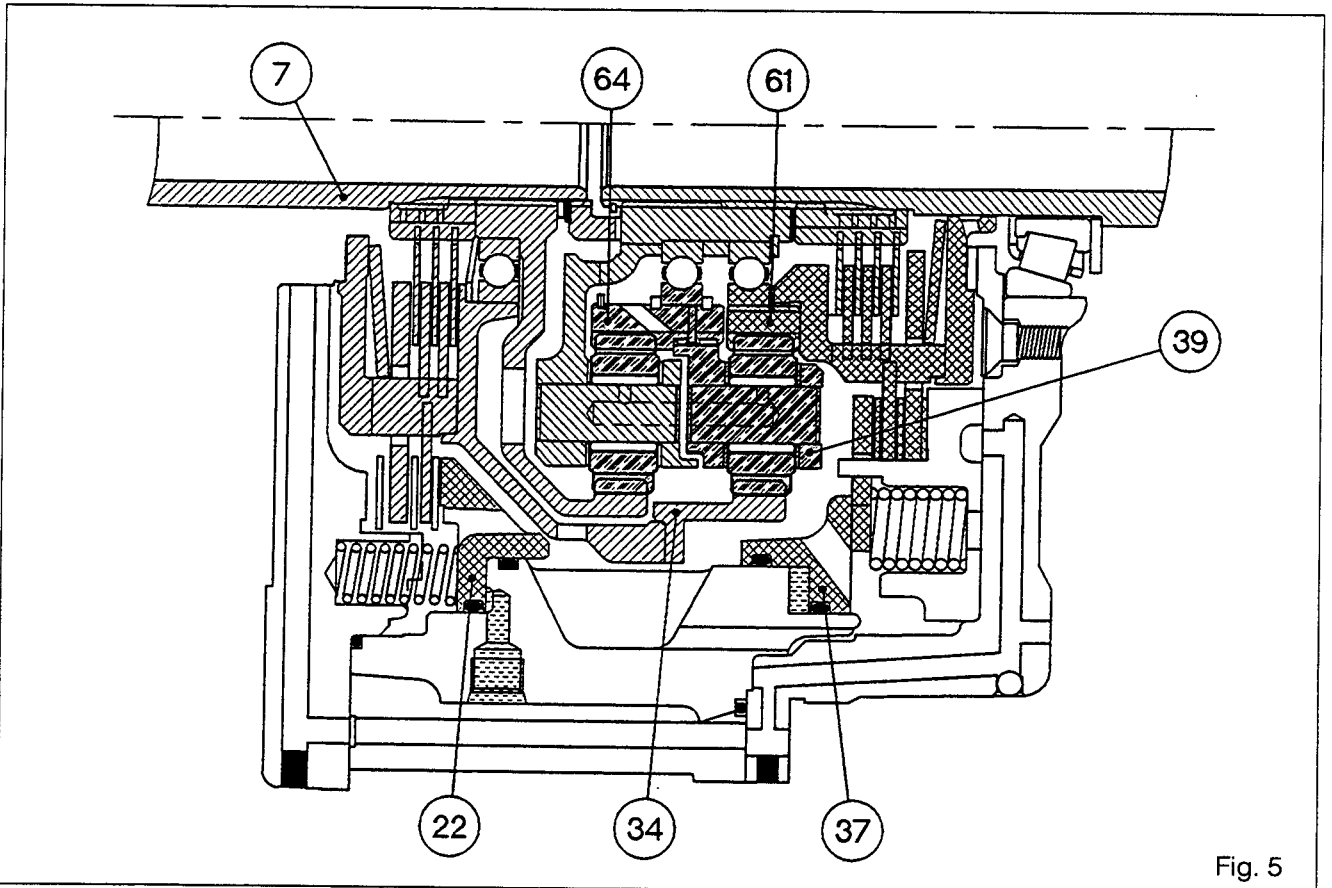

Fig. 5

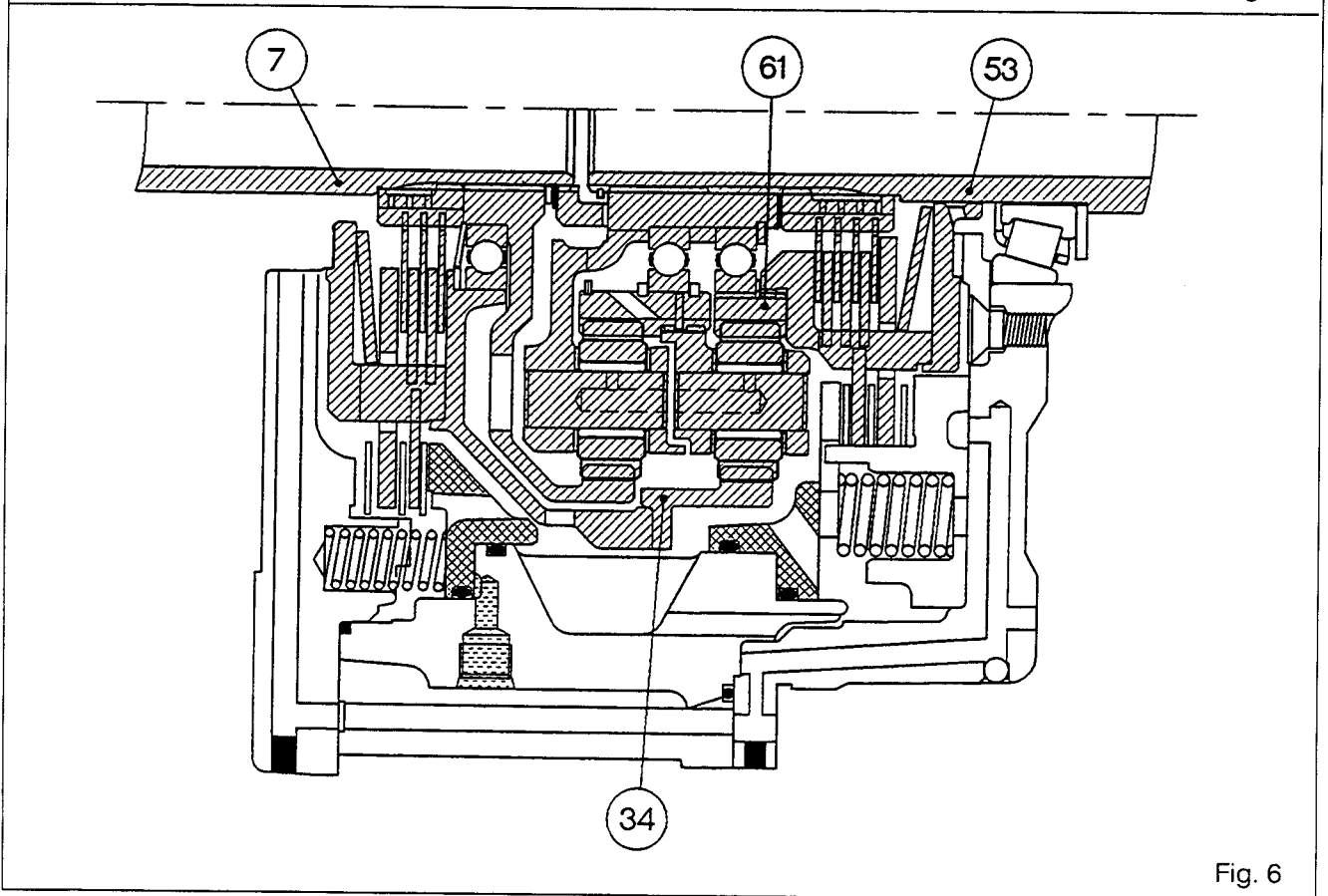

Fig. 6



5B03.8

## 6100 SERIES TRACTORS

**Gearbox - Dynashift****A. Preliminary operations**

1. Split the tractor between the engine and the gearbox.
2. Drain the oil from the gearbox and from the rear axle.
3. Remove the clutch, see Section 4A01 or 4B01 according to the type of clutch.
4. Remove the input unit, see Section 5B01.
5. Place the input unit in the vertical position.

**B. Removing and disassembling the cover, housing, front clutch and brake**

6. Using two lugs or two rings, manufactured locally, remove the assembly comprising the shaft (7), cover (13) and housing (21) (Fig. 7).
7. Recover the thrust washer (70). Compress the spring washer (77) by pressing on the ring gear (31). Remove the circlip (69) and withdraw the shaft (7).
8. Remove the piston (37) from the housing (21).
9. Using tool 3376888M1, immobilise the ring gear (34). Remove the bolts (25) (Fig. 8).
10. Withdraw the assembly comprising the secondary ring gear (34), ring gear carrier (1), ring gear (31) and bearing (27).
11. Separate the ring gear (34) from the ring gear carrier (1). Remove the spring washer (77) and the bearing (27).
12. Remove the housing (21) and the piston (22).
13. Remove the clutch driving plate (3), brake disc (15), clutch driven plate (2) and pressure plate (17), hub (5), springs (20) and backing plate (16).
14. Extract the Belleville washer (4) and the clutch housing (14).

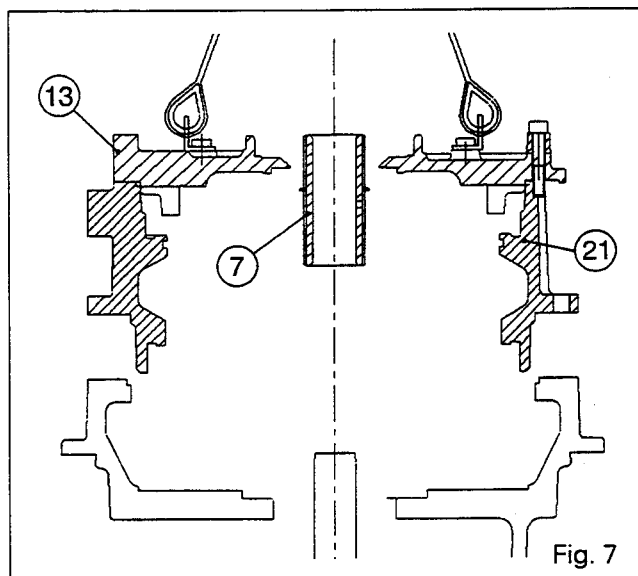

Fig. 7

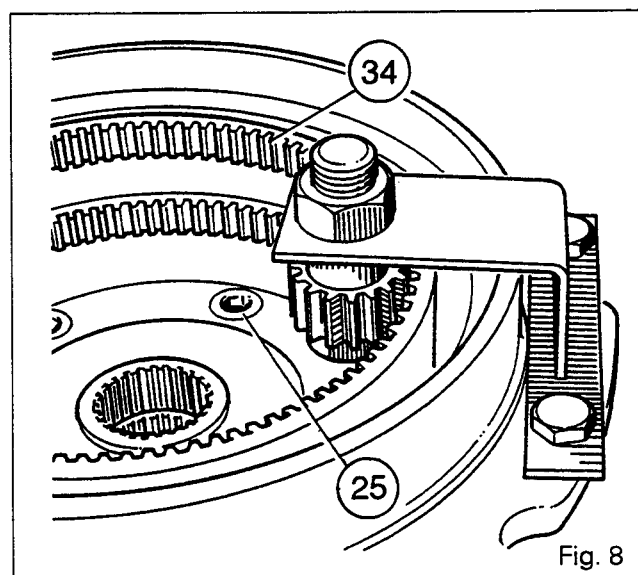

Fig. 8

**C. Removing and separating the planetary carrier assembly**

15. Compress the planetary carrier assembly using tool 3376920M1 (Fig. 9).
16. Remove the retaining ring (72). Remove the tab washer (76), the planetary carrier assembly and the shims [71].
17. Remove the secondary sun gear (61) and the retaining ring (49) (if necessary).

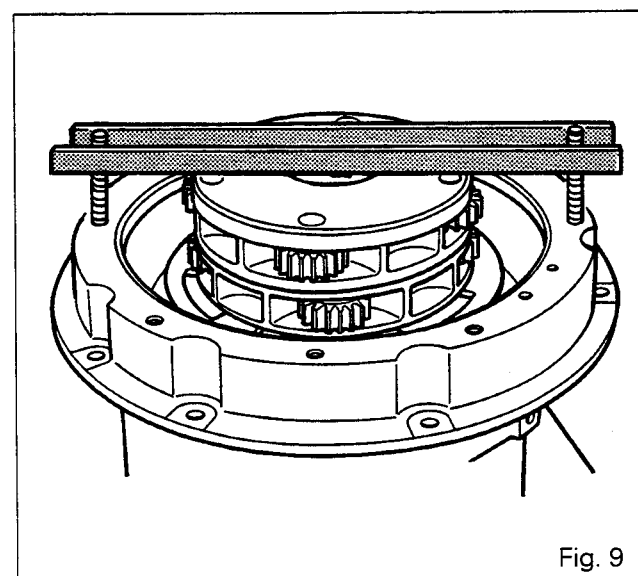

Fig. 9



## Gearbox - Dynashift

18. Remove the circlip (55). Remove the bearing (57) and the spacer (56).
19. Separate the secondary planetary carrier (39) from the primary planetary carrier (28).
20. Remove the retaining ring (60) and the bearing (58).
21. Place the secondary planetary carrier in the vertical position. Extract the needles (63) (Fig. 10) by lightly tapping on a wooden block. Separate the planetary carrier from the primary sun gear (64) fitted with the retaining ring (62) and the deflector (75).

### D. Disassembling the rear clutch and brake

22. Remove the pressure plate (38), the springs (65), and the brake discs (41) separated from the pressure plate (44).
23. Remove the housing assembly (59), the backing plate (45) and the last disc (41). Remove the thrust washer (51).
24. Take out the bolts (46). Remove the cover (47) and the Belleville washer (52). Separate the backing plate (45), the clutch driving plates (50) and the driven plates (48). Remove the hub (54).
25. Take out the bolts (43). Detach and remove the secondary brake housing (42), and mark its position.

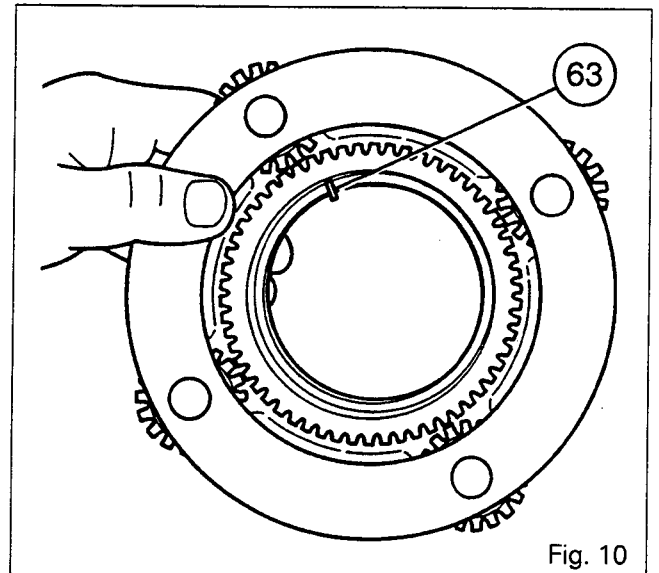

Fig. 10

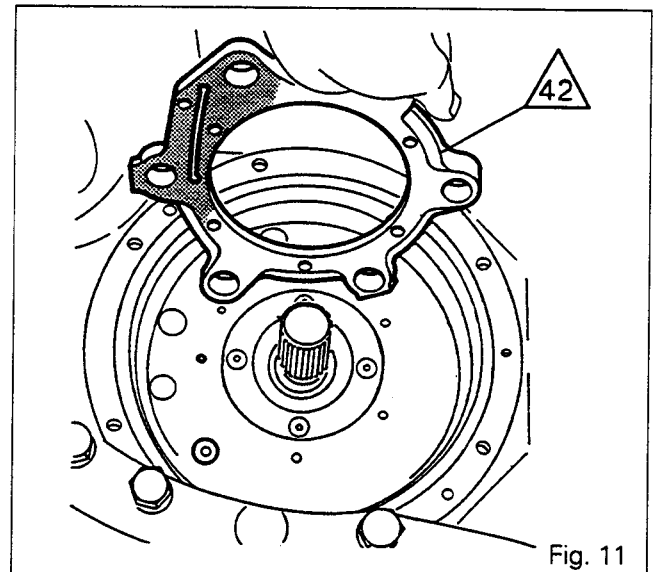

Fig. 11

### E. Assembling the planetary carriers

26. Clean and check the parts, and replace any that are faulty.
27. Check that the lubricating panels in the pins of the planetary carriers are not blocked.
28. Manually check the end play and rotation of each planetary pinion.
29. Fit the primary sun gear (64) along with the retaining ring (62) and oil deflector (75) on the secondary planetary carrier (39).
30. Slide the three needles (63) to each hole in the primary sun gear, fully home in the groove on the secondary planetary carrier.
31. Position the bearing (58) and fit the retaining ring (60).
32. Assemble the secondary planetary carrier on the primary planetary carrier (28). Turn the planetary pinions to facilitate meshing.
33. Position the spacer (56) and the bearing (57), and fit the circlip (55).
34. Manually check the backlash on the primary planetary pinions.
35. Fit the retaining ring (49) on the secondary sun gear (61) (if it was removed).

### F. Reassembling the rear clutch and brake

36. Clean and check the parts, and replace any that are faulty.
37. Direct a blast of compressed air into the channel in the reversing idler gear to ensure that it is not blocked.
38. Coat the mating face of housing (42) with a sealing compound around the lubricating pipe (Fig. 11) and then fit it.
39. Tighten the bolts (43) to a torque of 31 to 35 Nm after coating them with Loctite 241.



5B03.10

## 6100 SERIES TRACTORS

**Gearbox - Dynashift**

40. To gain access to bolts (46), turn over the planetary carriers. Fit the secondary sun gear (61), the rear clutch housing (59) and the hub (54) with its internal splines facing downwards (Fig. 12). Fit the rear clutch driving plates (50), the driven plates (48), the backing plate (45) and the Belleville washer /52\ in accordance with Fig. 1, and the cover (47).
41. Centre the rear clutch housing assembly (59) with tool 3376887M1 (Fig. 13). Coat the bolts (46) with Loctite 241 and tighten them to a torque of 13 to 15 Nm. Remove the tool. Separate the housing assembly from the planetary carriers.
42. Coat the thrust washer (51) with miscible grease and position it on the cover (47).
43. Fit a brake disc (41) in the housing /42\.
44. Position the rear clutch housing (59) and the thrust washer (51) on the secondary shaft (53). Fit the hub (54), with its internal splines facing upwards (Fig. 14).
45. Position the other two brake discs (41), separated by the pressure plate (44).

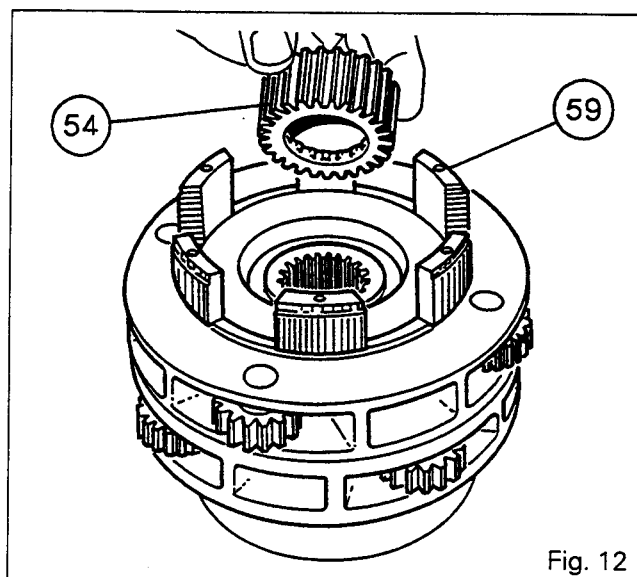

Fig. 12

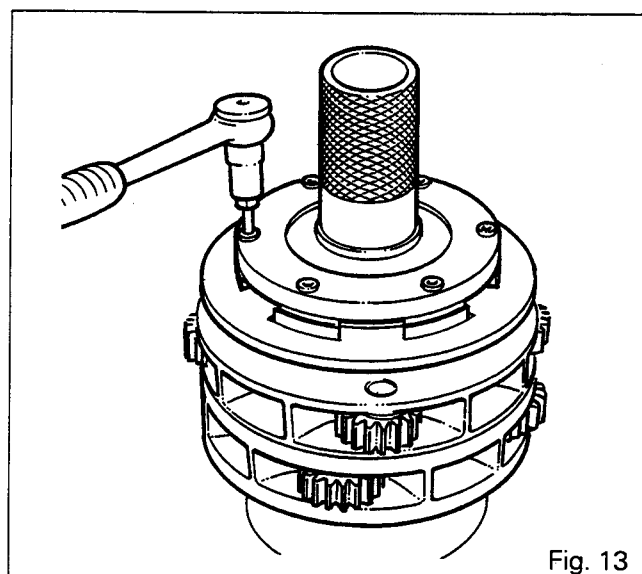

Fig. 13

**G. Reassembling the cover, front clutch, brake and housing**

46. Check that the plug (74) is in place.
47. Place the cover on a suitable support.
48. Fit the primary shaft (7) and the clutch housing (14).
49. Fit the Belleville washer /4\ as shown in Fig. 1, a brake disc (15) and the backing plate (16).
50. Fit the hub (5) on the primary shaft (7), with its internal splines facing upwards (Fig. 15). Fit the clutch driving plates (3) and the driven plates (2).
51. Position the other two brake discs (15), separated by the pressure plate (17).
52. Refit the springs (20). Fit the O-ring (73).
53. Check that plugs (23) and (29) are in place. Make sure that the channels on pistons (22) and (37) in the housing (21) are not blocked.
54. Lubricate the seals (24) and (26), and fit them on piston (22) and in housing (21), respectively.
55. Position the piston in the housing and fit it by knocking it gradually around the edge with a plastic-tipped mallet.
56. Screw two guide studs onto the housing (21) and position the housing on the cover (13). Check that the lubricating channel on the housing is correctly aligned with the one on the cover.

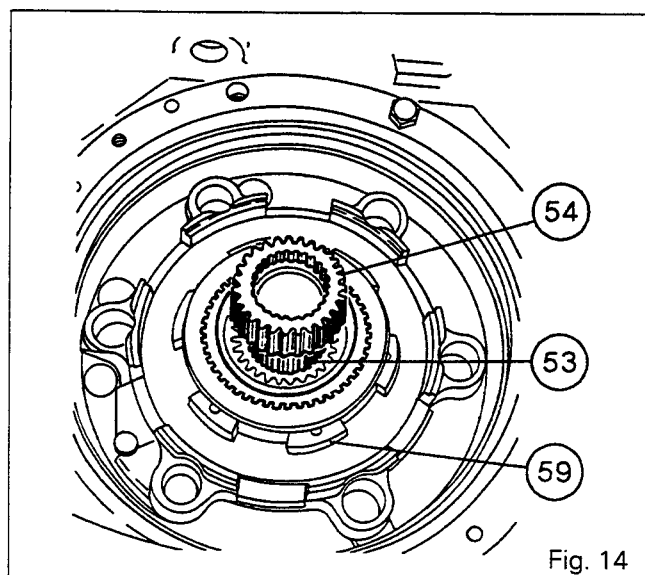

Fig. 14





**Note :** When the cover (13) of housing (21) or the reverse shuttle housing (40) is replaced, the shimming of the clutch must be checked and redone, if necessary (see section 4A01 or 4B01 according to version).

57. Remove the guide studs. Fit the bolts (18) and tighten them to a torque of 25 to 35 Nm.  
Connect a pressure gauge equipped with a valve on the port on the front piston. Supply the system with a compressed air pressure of 0.3 bar. Close the valve and check that no pressure drop occurs for one minute.
58. Refit the bearing (27) on the ring gear (31), and install it in the ring gear carrier (1) with the spring washer (77). Fit ring gear (34). Tighten the bolts (33) to a torque of 12 to 16 Nm, after coating them with Loctite 241.  
Fit the assembled ring gears on the primary shaft. Immobilise ring gear (34) as shown in Fig. 8. Tighten the bolts (25) to a torque of 31 to 35 Nm, after applying Loctite 241.
59. Compress the spring washer (77) by pressing on ring gear (31). Fit the circlip (69) and the thrust washer (70), coated with miscible grease.
60. Lubricate and fit the seals (35) and (36). Position the piston in the housing and fit it by knocking it gradually around the edge with a plastic-tipped mallet. Hold the piston with a suitable fixture. Check for leaks on seals, as for the front piston.

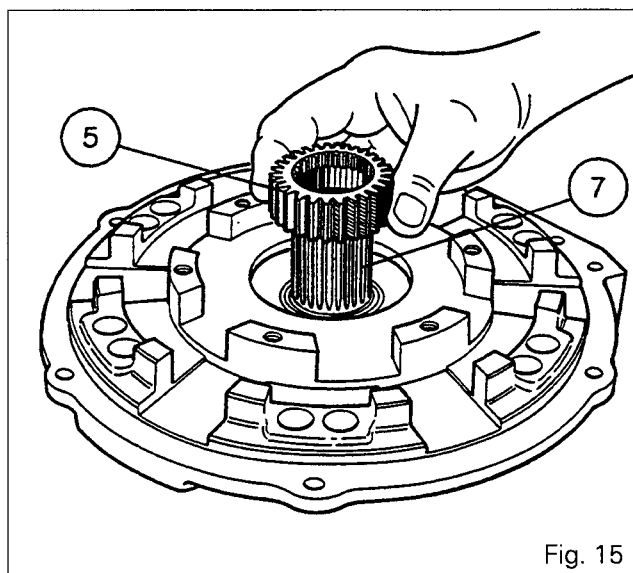

Fig. 15



5B03.12

# 6100 SERIES TRACTORS



## Gearbox - Dynashift

### H . Shimming the planetary carriers

Shimming J1 (Fig. 16)

**Note : The springs (65) and pressure plate (38) must be removed in order to carry out shimming operations J1 and J2.**

On the rear clutch unit (Fig. 18)

61. Use a depth gauge to measure dimensions **B** and **C**. Calculate the dimension : **A = C - B**

On the planetary carrier assembly (Fig. 17)

62. Fit the secondary sun gear (61) and its retaining ring (49) on the ball bearing (57).

63. Measure dimension **D** with a depth gauge.

64. Determine the clearance **E** between the primary planetary carrier (28) and the hub (54) (Fig. 19) using the formula : **E = D - A**

65. Take up clearance **E** by fitting shims [71] with a total thickness of **E** plus 0.50 minimum to plus 0.70 maximum.

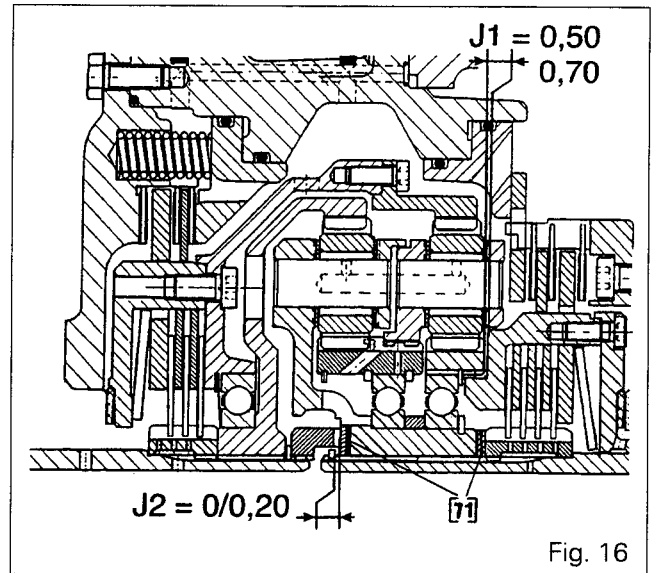

Fig. 16

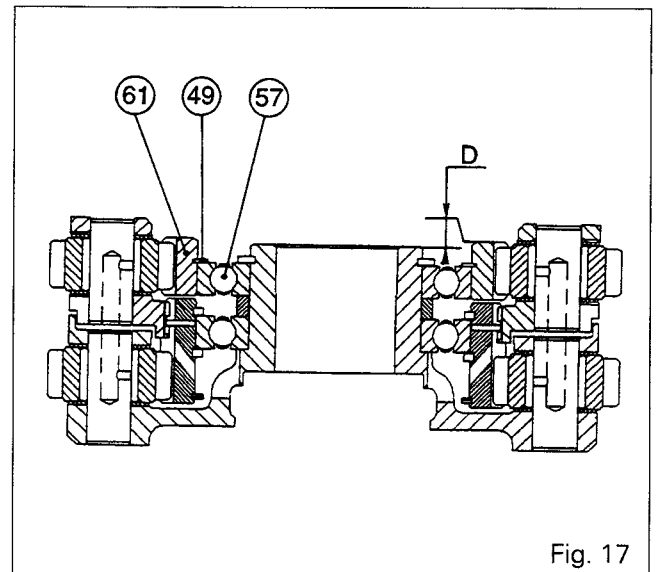

Fig. 17

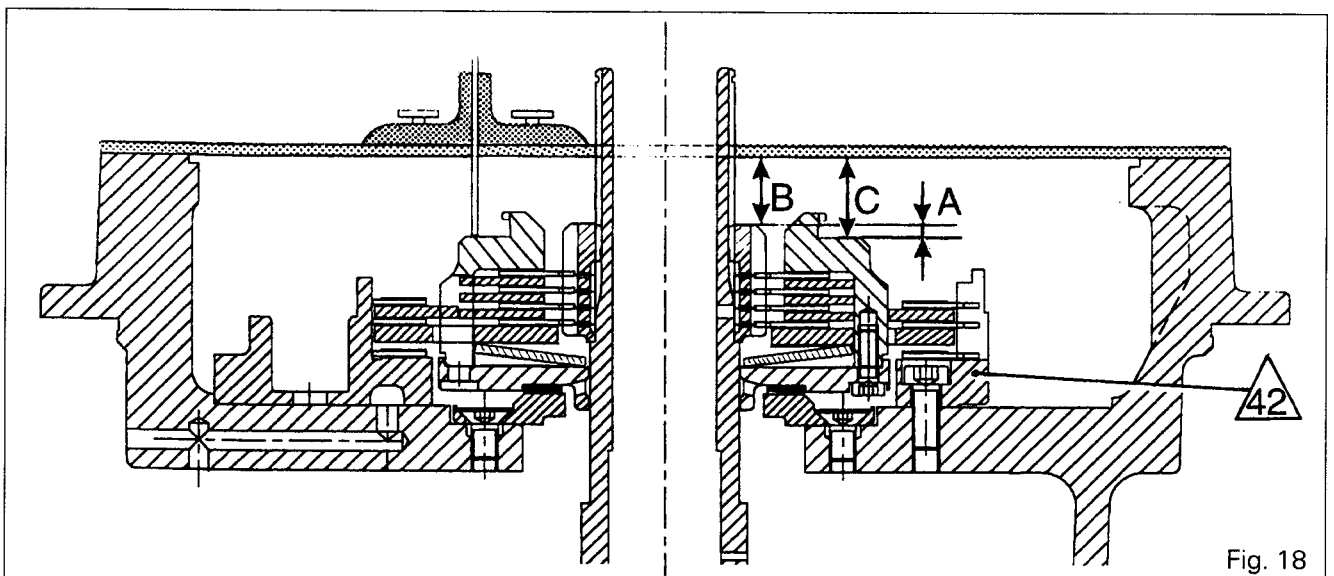

Fig. 18

**Shimming J2 (Fig. 16)**

66. Position the sun gear (61) on the housing (59) and position the planetary carrier assembly on shaft (53). Fit the tab washer (76) and retaining gear (72).
67. Place the tip of a dial gauge as per Fig. 20 and check the play by moving the planetary carrier assembly vertically.
68. According to the play measured, select a thickness of shims [71] to obtain  $J2 = 0$  to  $0.20$ .
69. Remove the planetary carrier assembly.
70. Fit the springs (65). Position the pressure plate (38), checking that the notches are aligned with the lugs on housing /42\.
71. Check that the shims [71] defined in procedure 65 are present.
72. Refit the sun gear (61) and the planetary carrier assembly, and compress with tool 3376920 M1.
73. Position the shims [71] selected in procedure 68 against the planetary carrier (28). Fit the tab washer (76) and retaining ring (72) (Fig. 20).
74. Check, by hand, for backlash on the secondary planetary pinions.

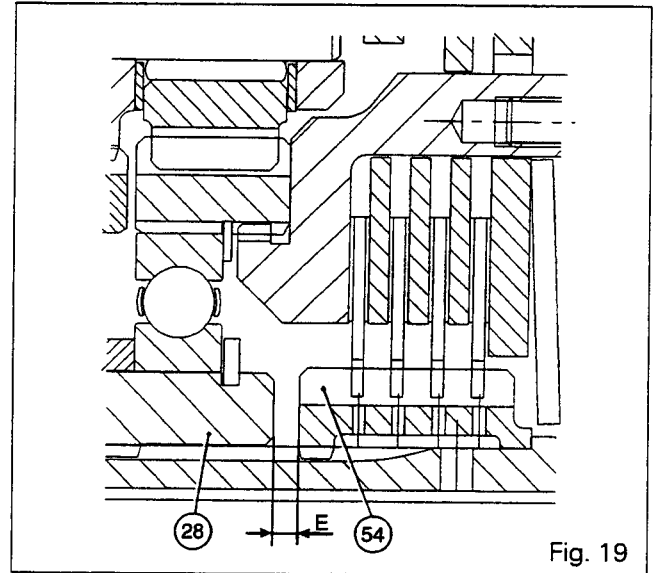

Fig. 19

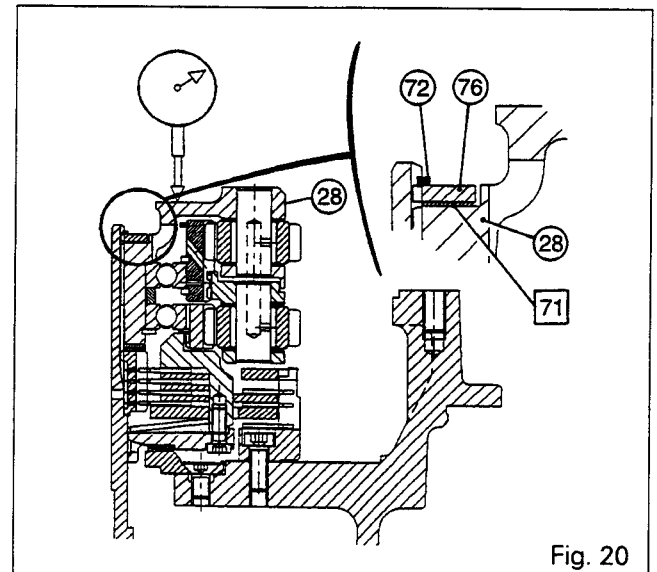

Fig. 20

**I. Assembling and refitting the input unit**

75. Position new O-rings (32) and (68) on the reverse shuttle housing (40). Screw two guide studs in diametrically opposite position.
76. Using a sling, refit the assembly comprising the primary shaft (7), cover (13) and housing (21) (Fig. 17), taking care to align the lubricating channel.
77. Turn the shaft so that the planetary pinions are meshed in the ring gears.
78. Take out the guide studs. Fit the bolts (30) and tighten them to a torque of 72 to 96 Nm.
79. Check that the shaft rotates satisfactorily.
80. Refit the input unit, see Section 5B01.



5B03.14

# 6100 SERIES TRACTORS



## Gearbox - Dynashift

### J. Service tools

#### 1. Tools available to the MF network

- Sling for front housing, ref. 3376883M1 (Fig. 21)
- Centring tool, ref. 3376887M1 (Fig. 22)
- Secondary ring gear holding tool, ref. 3376888M1 (Fig. 23)
- Secondary planetary carrier holding tool, ref. 3376920M1 (Fig. 24)
- Sleeve, ref. 3378004M1 (Fig. 25)
- Adapter plate for sling, ref. 3378013M1 (Fig. 25)

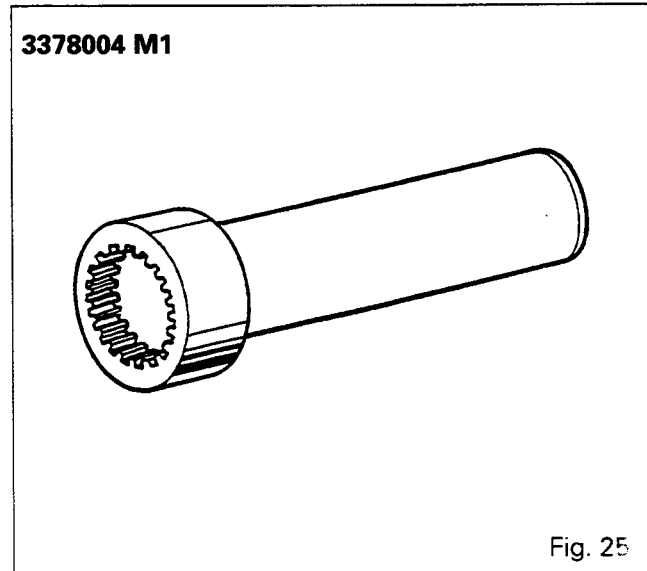
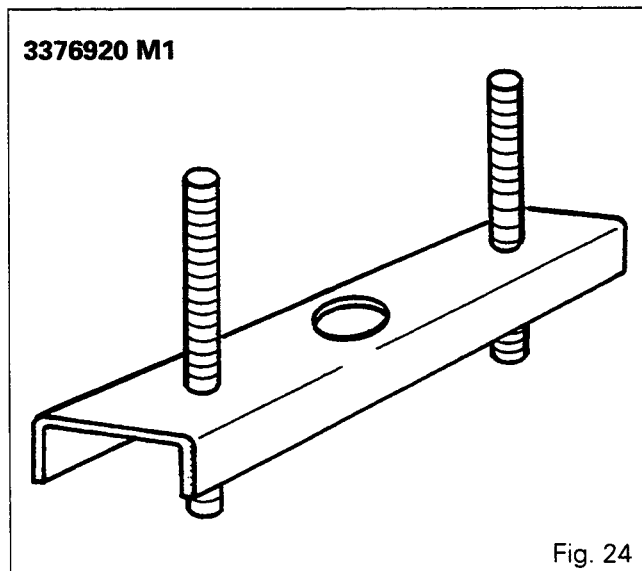
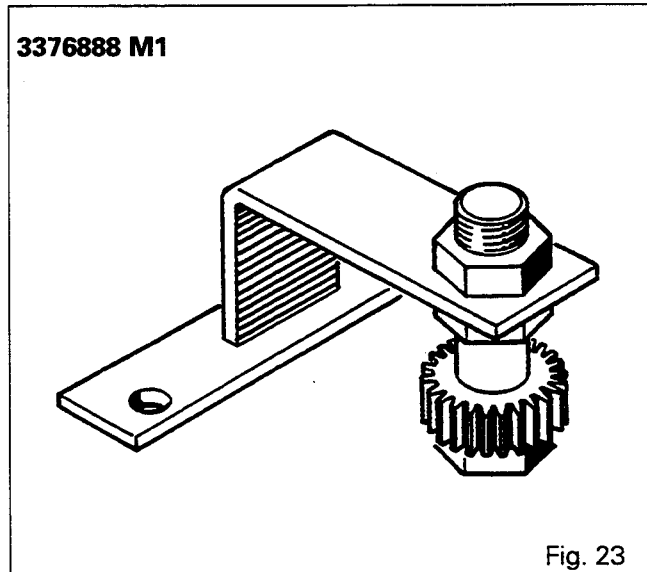
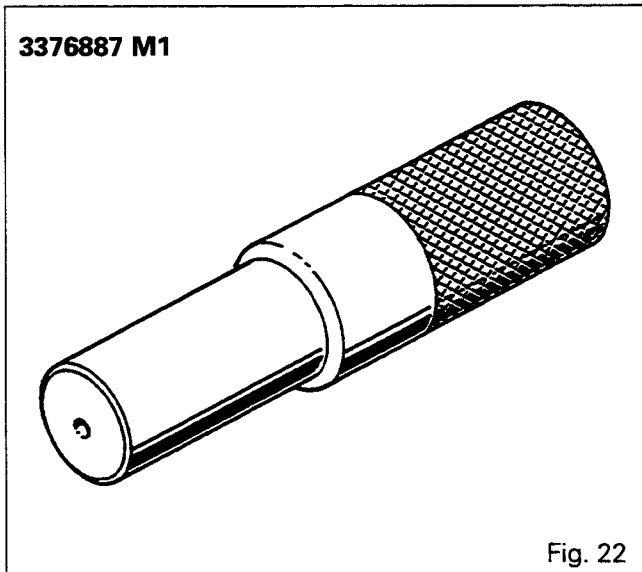
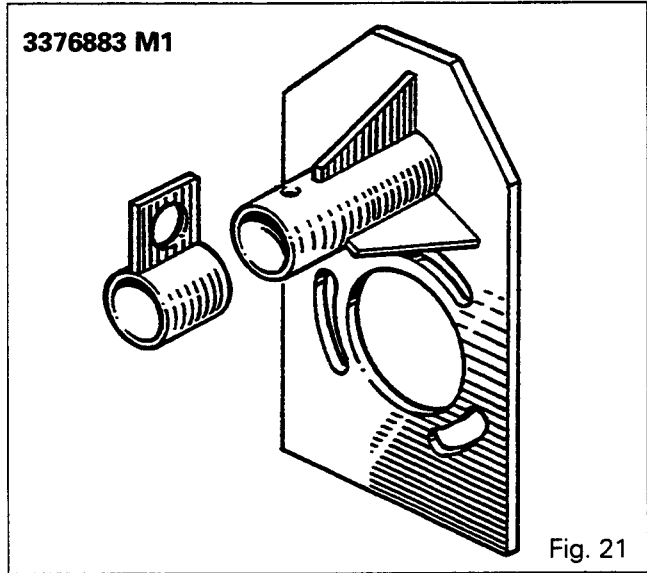



**Gearbox - Dynashift**

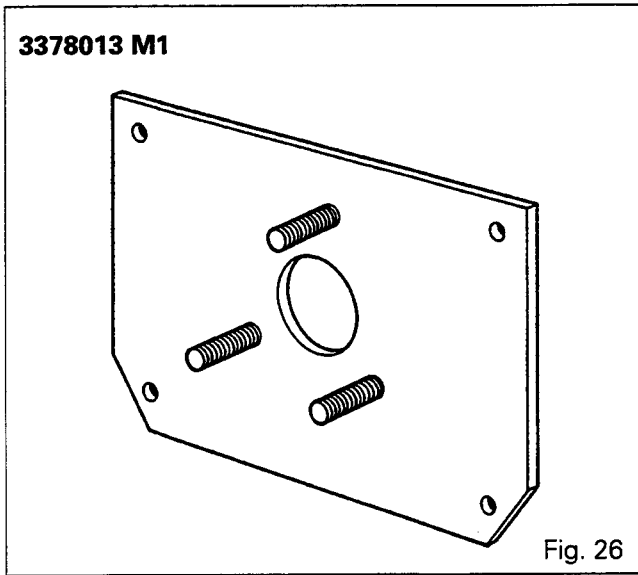

Tool to be manufactured locally

- Handling bar

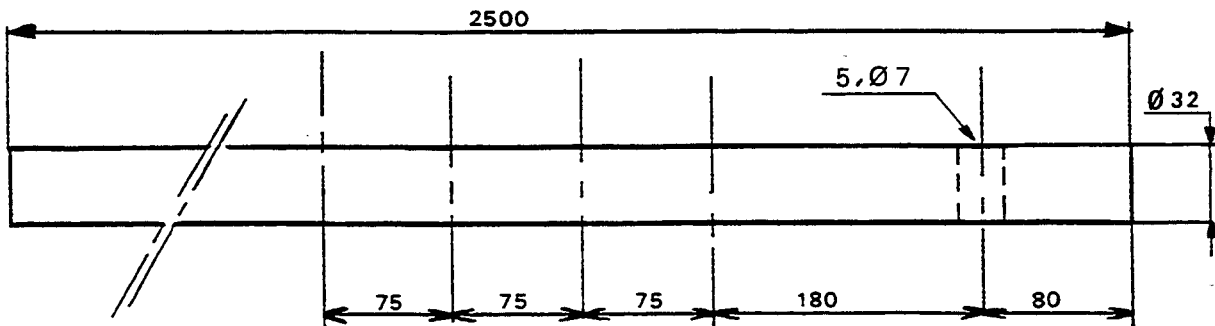





---

 6100 SERIES TRACTORS
 

---

## **Gearbox** - Reverse shuttle



5B04.1

### 5 B04 Reverse shuttle

#### CONTENTS

- <b>General</b> .....	2
- <b>Operation</b> .....	2
<b>A. Removing the input unit</b> .....	5
<b>B. Disassembling the Dynashift unit</b> .....	5
<b>C. Disassembling and reassembling the mechanical reverse shuttle</b> .....	5
<b>D. Reassembling the Dynashift unit</b> .....	7
<b>E. Assembling and refitting the input unit</b> .....	7
<b>F. Service tool</b> .....	9
<b>G. Disassembling and reassembling the electrohydraulic reverse shuttle</b> .....	9
<b>H. Speedshift version</b> .....	10



5B04.2

## 6100 SERIES TRACTORS

**Gearbox - Reverse shuttle****General**

The function of the reverse shuttle is to transmit motion from the Speedshift or Dynashift via a gear **(67)** to the mainshaft **(69)** fitted on the front of the main gearbox. The reverse shuttle assembly is housed in the recess at the back of the input unit, behind the Speedshift or the Dynashift. It consists of the following components:

- Two helical-toothed gears **(5)** and **(23)** mounted on needle-roller bearings **(6)** and **(20)**
- A synchromesh assembly **(18)** the hub of which is splined onto the secondary shaft **(19)**  
The synchromesh can be of the following types:
  - . Single cone:
    - Standard mechanically operated gearbox,
  - . Double cone:
    - Standard electrohydraulically operated gearbox,
    - Heavy duty gearbox, all types.
- A selector rail and fork assembly operating the synchromesh
- A secondary shaft **(19)** mounted either on taper-roller bearings in the Dynashift version or on two ball bearings in the Speedshift version, supported by two journal bearings on the reverse shuttle housing
- A compound drive gear **(15)** in constant mesh with gear **(23)** and the gearbox input gear **(67)**

**Operation****Forward motion**

When the synchromesh pusher is moved rearwards, it couples gear **(5)** with the secondary shaft **(19)** and gear **(67)** with mainshaft **(69)**. Gear **(5)** drives gear **(67)** with which it is in constant mesh.

**Reverse**

When the pusher is moved forwards, it couples gear **(23)** and the secondary shaft **(19)**. Drive is transmitted via gear **(23)**, the teeth on gear **(15)**, gear **(67)** and the mainshaft **(69)**.

**List of parts**

- |  |                                |
|--|--------------------------------|
| <b>[1]</b> Shims                           | <b>(21)</b> Synchro ring       |
| <b>(2)</b> Synchro hub                     | <b>(22)</b> Synchro cone       |
| <b>(3)</b> Synchro ring                    | <b>(23)</b> Gear               |
| <b>(4)</b> Synchro cone                    | <b>(24)</b> Front bearing cone |
| <b>(5)</b> Gear                            | <b>(25)</b> Locking plate      |
| <b>(6)</b> Needle-roller bearing           | <b>(26)</b> Housing            |
| <b>/7\</b> Bush                            | <b>(27)</b> Locking plunger    |
| <b>/8\</b> Friction washer                 | <b>(28)</b> Spring             |
| <b>(9)</b> Rear bearing cone               | <b>(29)</b> Plug               |
| <b>(10)</b> Set screw                      | <b>(30)</b> Fork               |
| <b>(11)</b> Spacer                         | <b>(31)</b> Selector rail      |
| <b>(12)</b> Friction washer                | <b>(32)</b> Adjusting screw    |
| <b>(13)</b> Reverse gear pin               | <b>(33)</b> Selector           |
| <b>(14)</b> Needle-roller bearing          | <b>(34)</b> Adjusting screw    |
| <b>(15)</b> Reverse compound gear          | <b>/35\</b> Friction washer    |
| <b>(16)</b> Needle-roller bearing          | <b>(36)</b> Bolt               |
| <b>(18)</b> Synchromesh and gears assembly | <b>(37)</b> Front cup          |
| <b>(19)</b> Secondary shaft                | <b>(38)</b> Rear cup           |
| <b>(20)</b> Needle-roller                  | <b>(39)</b> Ball               |





# Gearbox - Reverse shuttle

Overall view (Dynashift with single cone synchromesh)

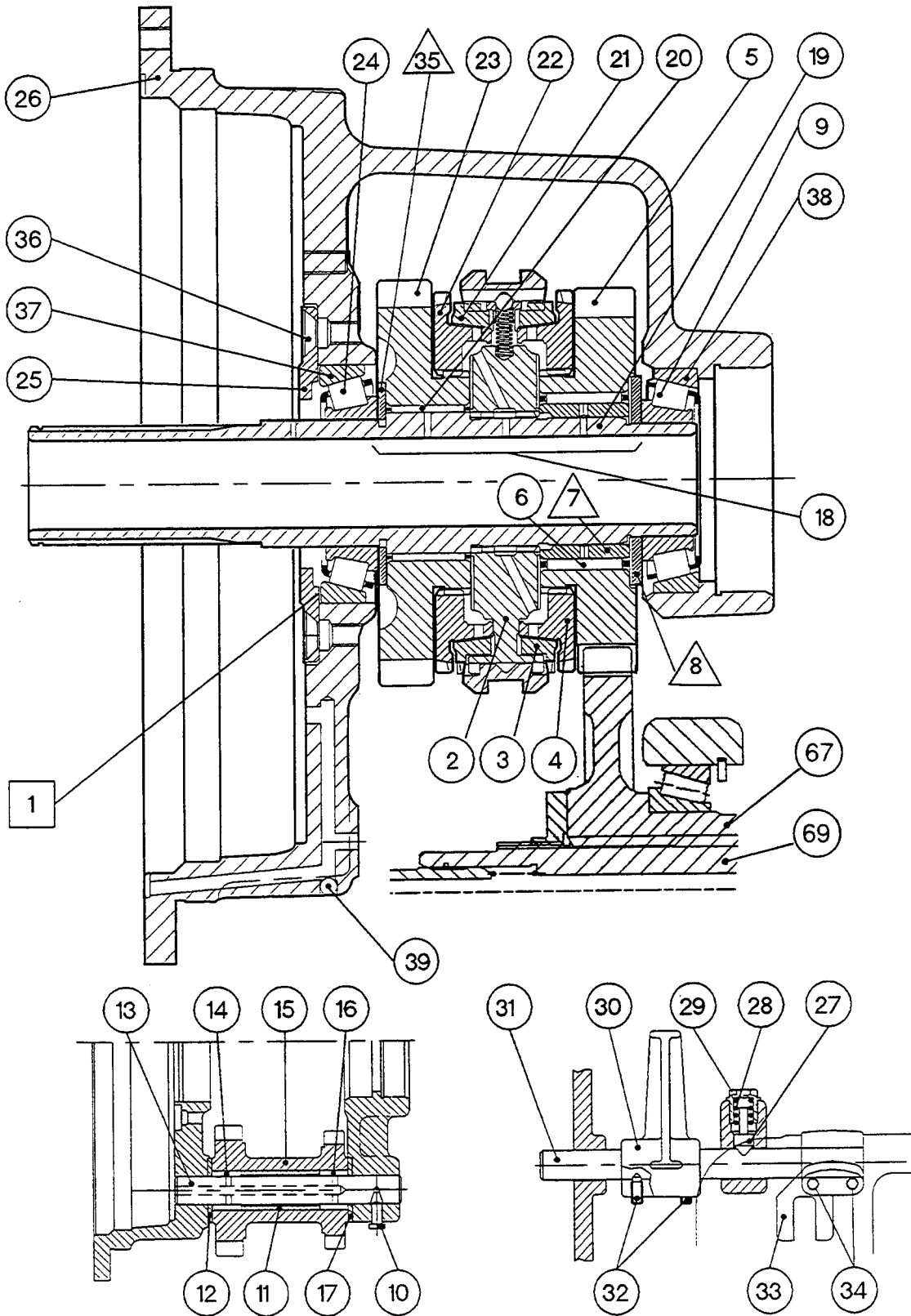

Fig. 1



5B04.4

6100 SERIES TRACTORS



**Gearbox - Reverse shuttle**

Exploded view

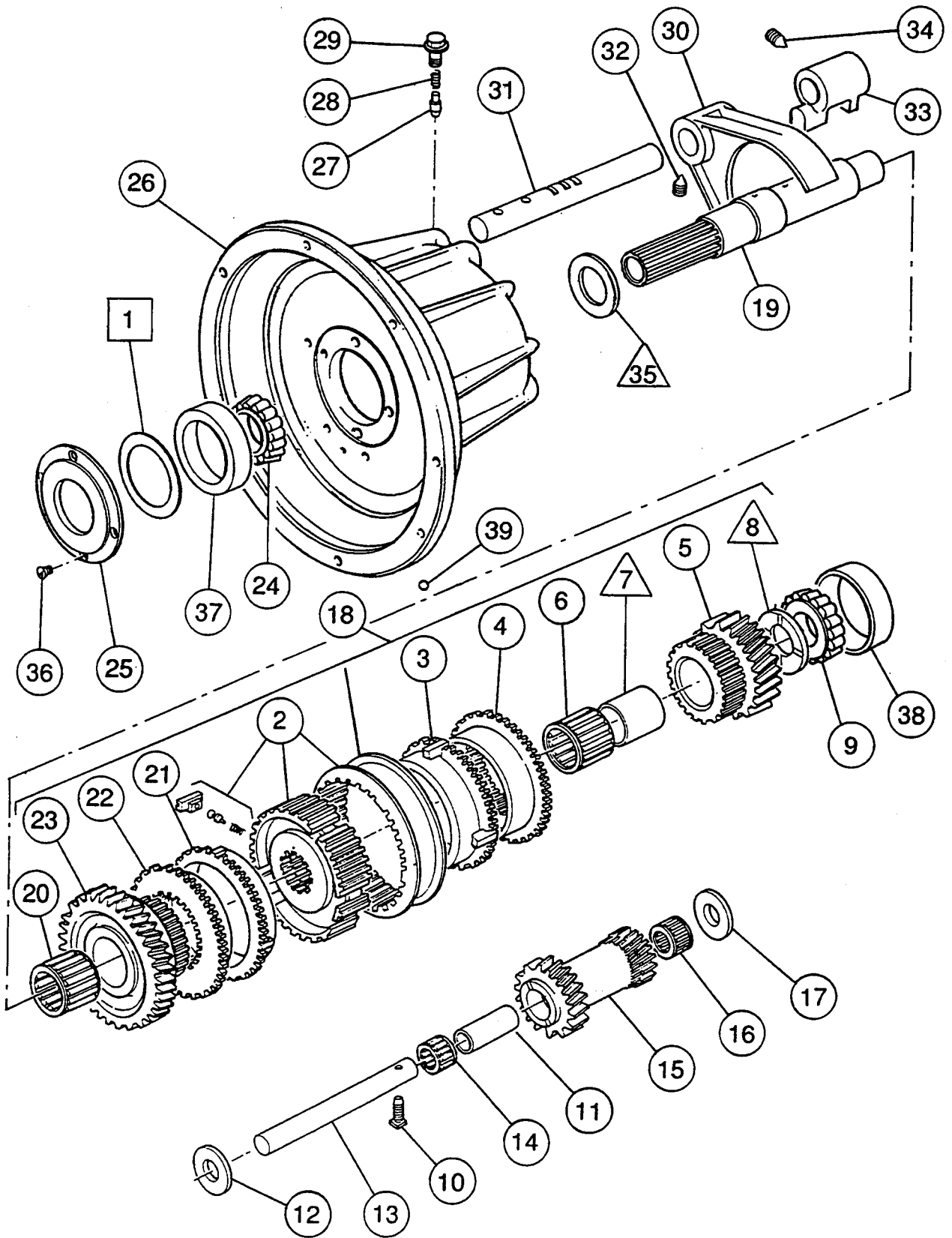

Fig. 2



## Gearbox - Reverse shuttle

### A. Removing the input unit

#### Version with shimming of layshaft

**Example:** Replacing the reverse shuttle housing (26). The gearbox must be removed to allow correct shimming of the layshaft bearings.

1. Split the tractor between the gearbox and the rear axle assembly (Section 2B01).
2. Remove the selector cover, see Section 5C01 or 5C02 according to version.
3. Separate the gearbox from the engine, see Section 2A01.
4. Remove the clutch, see section 4A01 or 4B01 according to version.

#### Version without shimming of layshaft

5. Split the tractor between the engine and the gearbox (See Section 2A01).
6. Remove the clutch, see Section 4A01 or 4B01 (according to version).
7. Remove the selector cover, see Section 5C01 or 5C02 (according to version).

#### Version with or without shimming of layshaft

8. Remove the screws (34). Remove the reverse selector (33) (Fig. 8) and the input unit (Section 5B01).
9. Remove the plug (29), the spring (28) and the locking pin (27). Take out the screws (32). Remove the selector rail (31) and the fork (30).  
**Note: The locking pin (27) is not interchangeable with those for 1st/2nd and 3rd/4th gears on the gearbox.**
10. Place the input unit in the vertical position.

### B. Disassembling the Dynashift unit (See 5B03)

11. Remove the assembly comprising the cover (13) and housing (21).
12. Remove the planetary carrier assembly.
13. Remove the rear clutch and the brake.

### C. Disassembling and reassembling the mechanically operated reverse shuttle

#### Disassembly

14. Remove the set screw (10). Withdraw the gear pin (13). Remove the reverse double gear (15), the washers (12) and (17), the needle roller bearings (14) and (16), and the spacer (11).
15. Remove the bolts (36). Remove the locking plate (25), the shims [1] and the cup (37).
16. Extract the secondary shaft (19) (Fig. 3).
17. Remove the gear/synchromesh assembly (18) (Fig. 3) and the friction washer /8.
18. Remove the cone (9) and the cup (38).
19. On the gear/synchromesh assembly, separate: gear (5), bush /7, needle roller bearing (6), synchromesh cone (4), ring (3), synchromesh (2), ring (21), cone (22), gear (23) and needle roller bearing (20).
20. If necessary, extract cone (24) from the shaft and remove the friction washer /35.

#### Reassembly

21. Clean and check the parts, and replace any that are faulty.
22. On the secondary shaft (19), the gear pin (13) and the housing (26), check that the ports and channels are not blocked. Check that the ball (39) is in place.
23. Lubricate the shaft, the cones, the cups and the bearings.
24. Check the play between the synchromesh rings and the cones, see Section 5A01 (mechanically operated reverse shuttle unit).

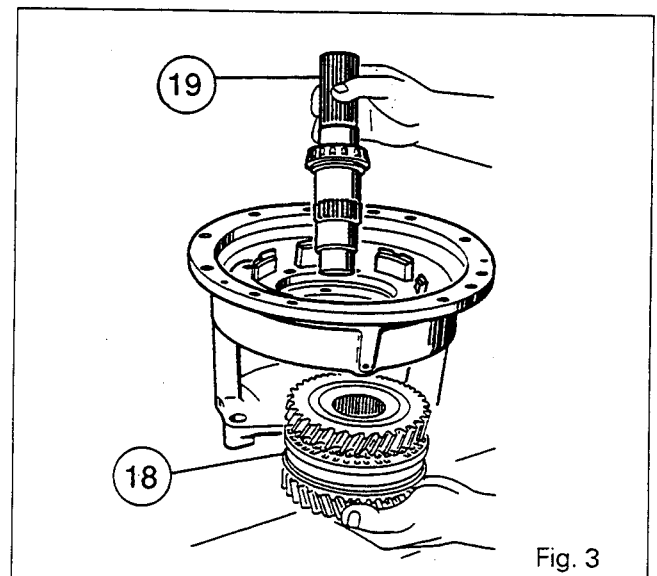

Fig. 3



5B04.6

## 6100 SERIES TRACTORS

**Gearbox - Reverse shuttle**

25. Fit the friction washer /35\ (if it was removed), with the grooves facing gear (23).

Fit the cone (24) pressed against the friction washer, using a press and a suitable fixture.

26. Assemble gear (5) and the bush /7\, with the shoulder facing the synchromesh. Fit needle roller bearing (6), synchro cone (4), synchro ring (3), the synchromesh, synchro ring (21), synchro cone (22), gear (23), and needle roller bearing (20).

27. Carry out procedures 17 and 18 in reverse order.

**Note: Place the friction washer /8\ with the lubricating channels towards gear (5) (Fig. 4).**

28. Centre the friction washer /8\. Passing via the bore in the front of the unit, fit the secondary shaft (19) in the gear/synchromesh assembly (18), with shoulder «E» pressed against the synchromesh (2) (Fig. 5).

29. Position the cup (37) and the locking plate (25) without shims [1].

30. Fit the bolts (36) and tighten them to a torque of 36 to 46 Nm.

31. Position the unit in a vice.

32. Carry out shimming (Fig. 7) to obtain preloading of:  $P1 = 0.05 / 0.15$

33. Place the dial gauge on the end of the secondary shaft (19) (Fig. 6).

34. Pull the shaft while turning it alternately to the left and right in order to seat the cones correctly in the cups.

35. Reset the dial gauge.

36. Repeat procedure 34, while pushing on the shaft.

**Note: In order to obtain correct preloading, reduce the end play to obtain a value of between 0.10 and 0.15.**

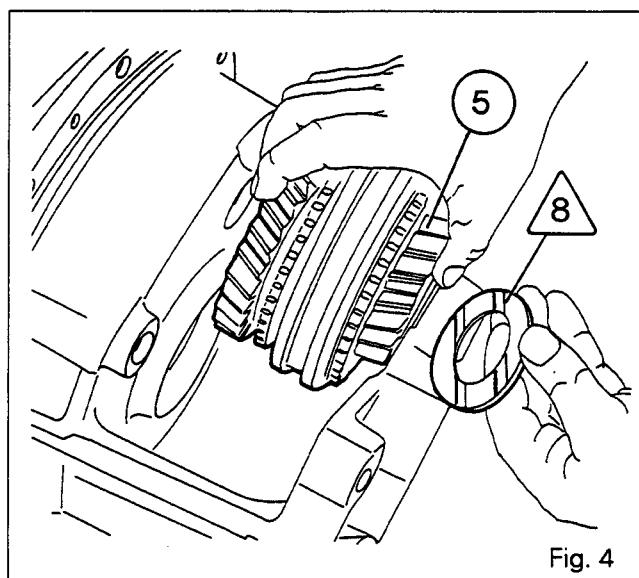

Fig. 4

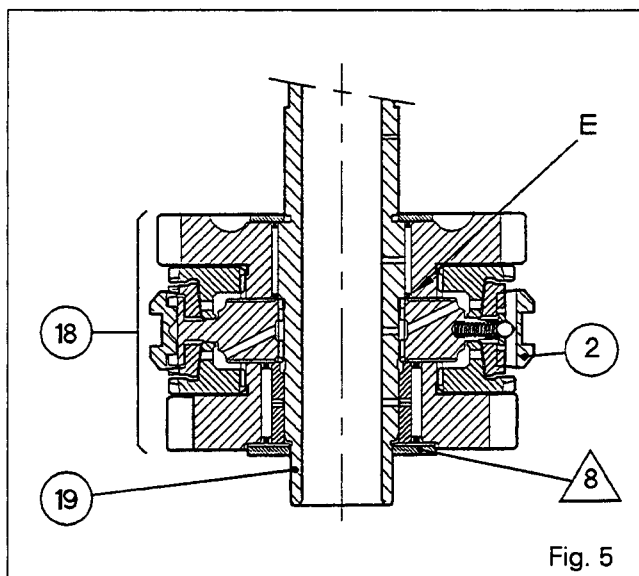

Fig. 5

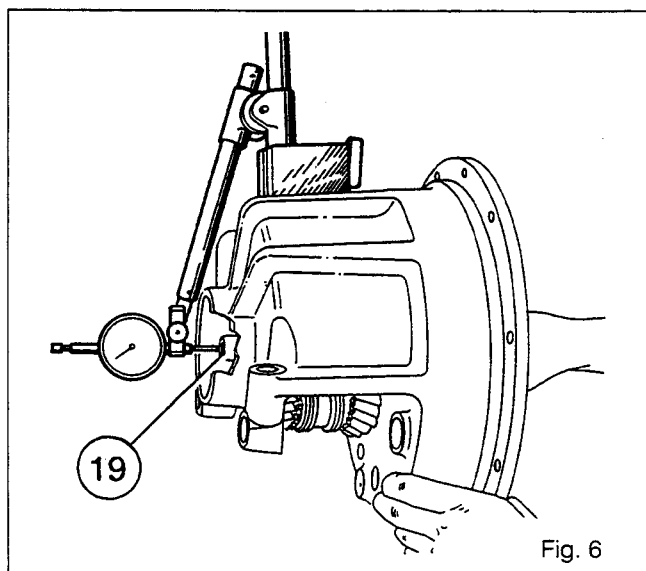

Fig. 6

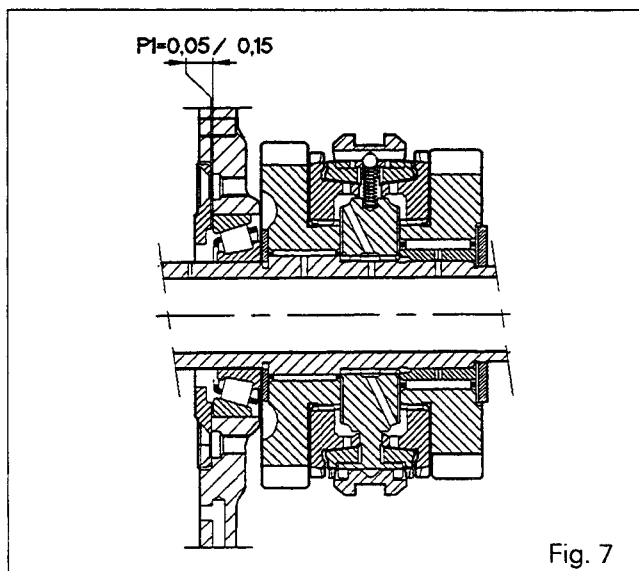

Fig. 7



## Gearbox - Reverse shuttle

37. According to the play measured, select the thickness of shims [1] required to obtain P1.
38. Place the unit in the vertical position. Remove the bolts (36). Remove the locking plate (25).
39. Fit the shims selected in procedure 37, making sure that they are correctly centered on the cup (37).
40. Fit the locking plate (25). Fit the bolts (36) after coating them with Loctite 241, and tighten to a torque of 36 to 46 Nm.
41. Check the end play and rotation of the gears (5) - (23). Manually check the rotation of the secondary shaft (19).
42. Fit the reverse double gear (15). Carry out procedure 14 in reverse order.
43. Coat the set screw (10) with Loctite 241 and tighten it to a torque of 28 to 43 Nm.
44. Manually check the end play and the backlash on the reverse double gear.

### D. Reassembling the Dynashift unit

45. Refit the rear clutch, the brake and the planetary carrier assembly, see Section 5B03.  
**Note: The planetary carrier must be shimmed if maintenance work is carried out on the housing (26) and the locking plate (25).**  
If shimming is necessary, see Section 5B03.

### E. Assembling and refitting the input unit

46. Fit new O-rings (32), (68) and (67), respectively, on the reverse shuttle unit (26) and the housing (21) (see Section 5B03).
47. Refit the assembly comprising the cover (13) and housing (21) (See section 5B03).
48. Check the rotation of the shaft.
49. Clean the tapped holes in the fork.
50. Fit and adjust the fork.

#### Principle

The positioning of the fork (30) is determined by the difference between the distance Y between the holes and the distance Z between the indents on the selector rail (31). The movement of the fork is changed by acting on either the front or rear screw (32) according to the adjustment required (Fig. 9).

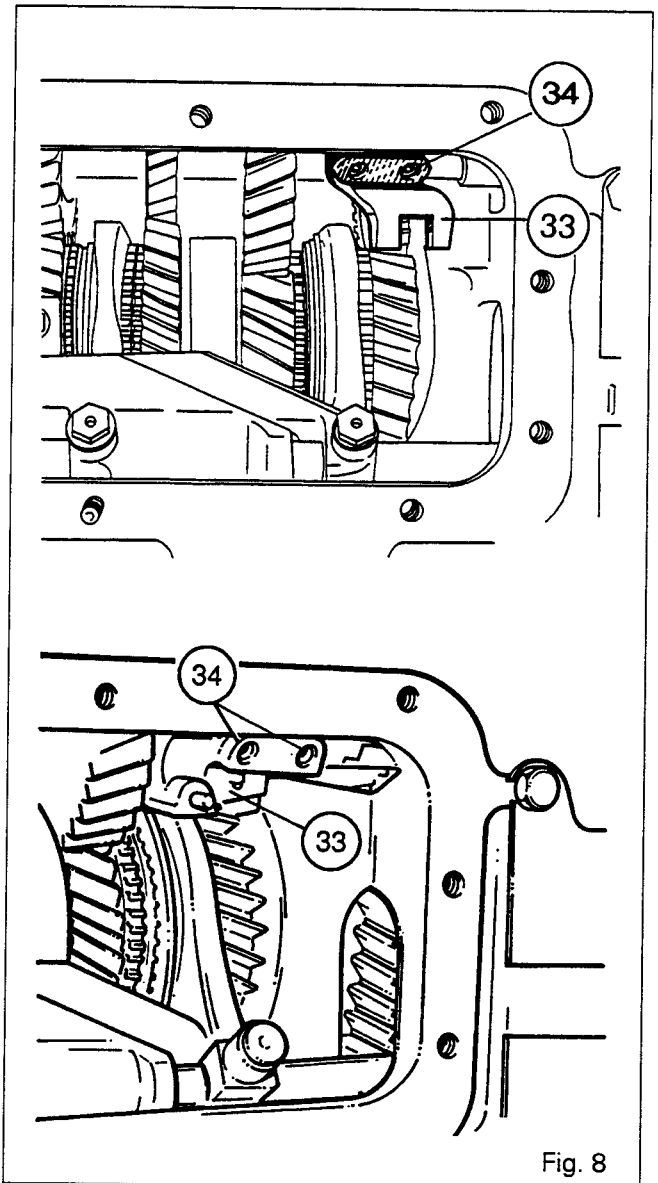

Fig. 8

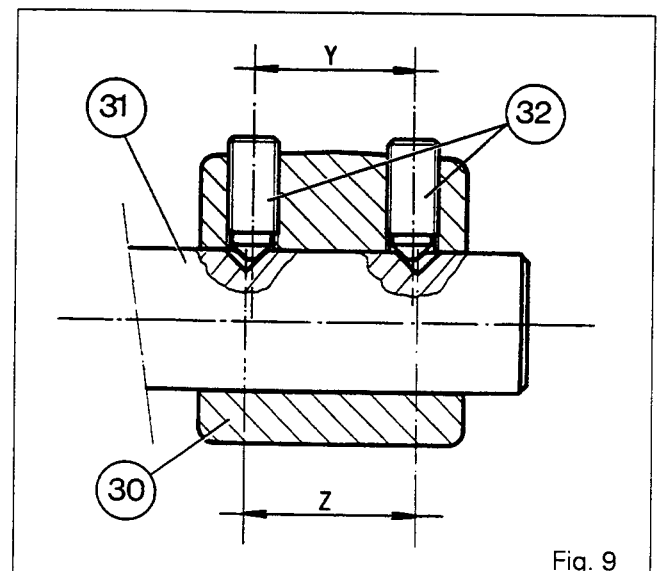

Fig. 9



5B04.8

## 6100 SERIES TRACTORS

**Gearbox - Reverse shuttle**

51. Fit the fork (30), the locking pin (27), the spring (28) and the plug (29). Tighten the plug to a torque of 50 to 70 Nm. Fit the screws (32) coated with Loctite 221.
52. Position the fork locked in the forward direction. Keep the synchronesh pusher pressed against the gear.
53. After adjustment, check that the front shoes on the fork are not in contact with the synchronesh pusher.
54. Repeat the operation (with the fork locked in the rearward direction). After adjusting, check that the rear shoes are not in contact with the synchronesh pusher.
55. Tighten the screws to a torque of 35 Nm without modifying the adjustment.
56. Refit the input unit, see Section 5B01.

**Version with shimming of layshaft**

57. Shim the layshaft, see Section 5F01.
58. Adjust the reverse selector (Fig. 10). Position the selector (33) at the neutral point. Fit and tighten tool 3778054M1 with bolts «V». Coat the screws (34) with Loctite 221. Bring face «F» of the selector into contact with the tool by means of screws (34).
59. Refit the selector cover, see Section 5C01 or 5C02 according to version.
60. Recouple the gearbox with the engine, see Section 2A01.
61. Recouple the tractor between the gearbox and the rear axle assembly, see Section 2B01.

**Version without shimming of layshaft**

62. Adjust the reverse selector. Carry out procedure 58.
63. Refit the selector cover, see Section 5C01 or 5C02 according to version.
64. Recouple the tractor between the engine and the gearbox, see Section 2A01.

**With or without shimming of layshaft**

65. Top up the rear axle assembly with oil. Reset the reverse shuttle electrohydraulic control system (if fitted) (See Section 5C02). Bleed the clutch or the control, see Section 4A01 or 4B01 according to version.
66. Carry out road test on all the controls.
67. Check the mating faces and hydraulic unions for leaks.

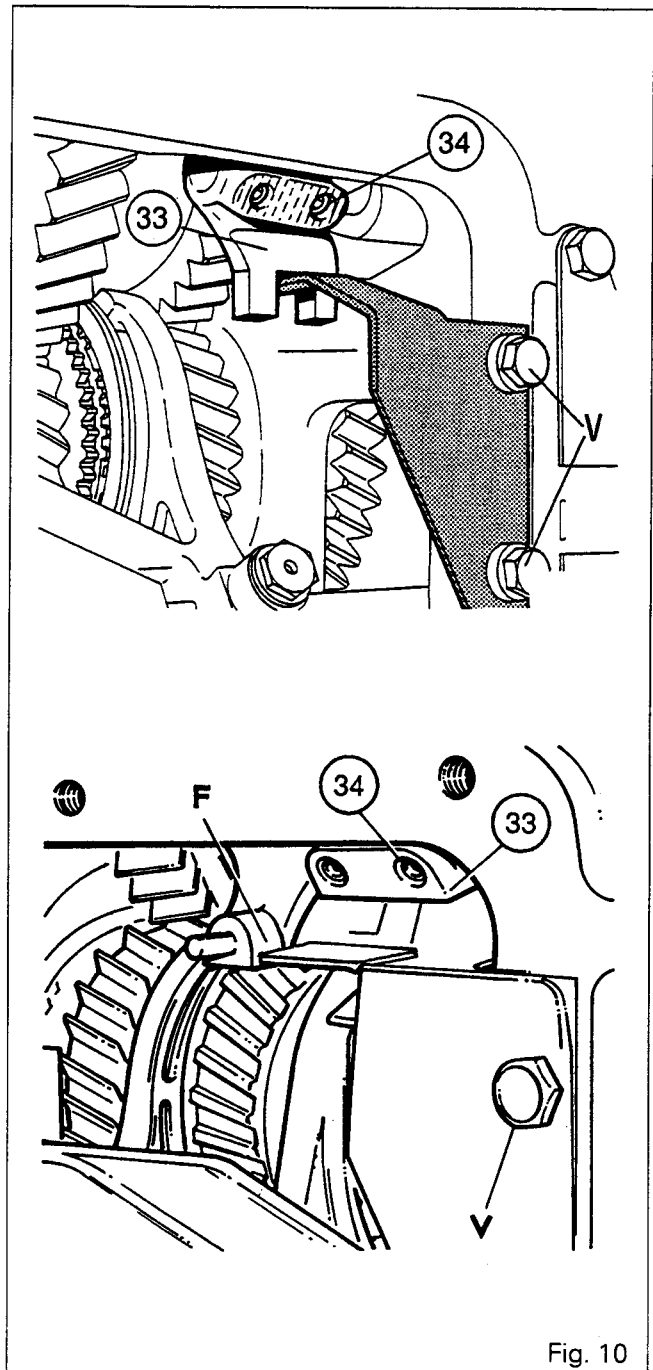

Fig. 10



# Gearbox - Reverse shuttle

5B04.9

## F. Service tool

3378054M1 - Adjusting template

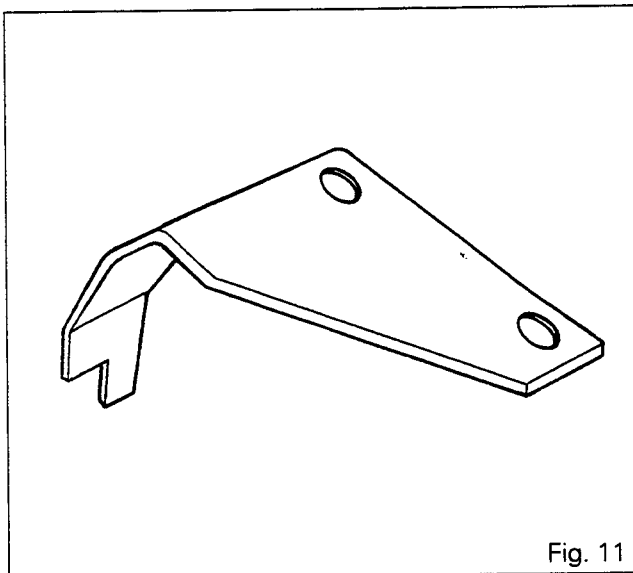

Fig. 11

## G. Disassembling and reassembling the electrohydraulically controlled reverse shuttle

### List of parts (Fig. 12)

- (1) Shims
- (2) Pusher
- (3) Ring
- (4) Cone
- (5) Cone
- (6) Coupling plate
- (7) Hub
- (8) Washer
- (19) Secondary shaft
- (25) Locking plate
- (26) Coupling plate
- (35) Washer
- (36) Bolt
- E Shoulder

### Preliminary operations

- 68. Remove the input unit (See Part A)
- 69. Disassemble the Dynashift unit (See Part B).

### Disassembly

- 70. Remove the reverse shuttle (Fig. 12).
- The work procedure on the electrohydraulically controlled reverse shuttle housing is identical to that on the housing with single cone synchromesh (Dynashift).
- The shimming procedure for the shaft (19) (Fig. 12), the adjustment of the fork (30) (Fig. 13) and tightening torques are unchanged.

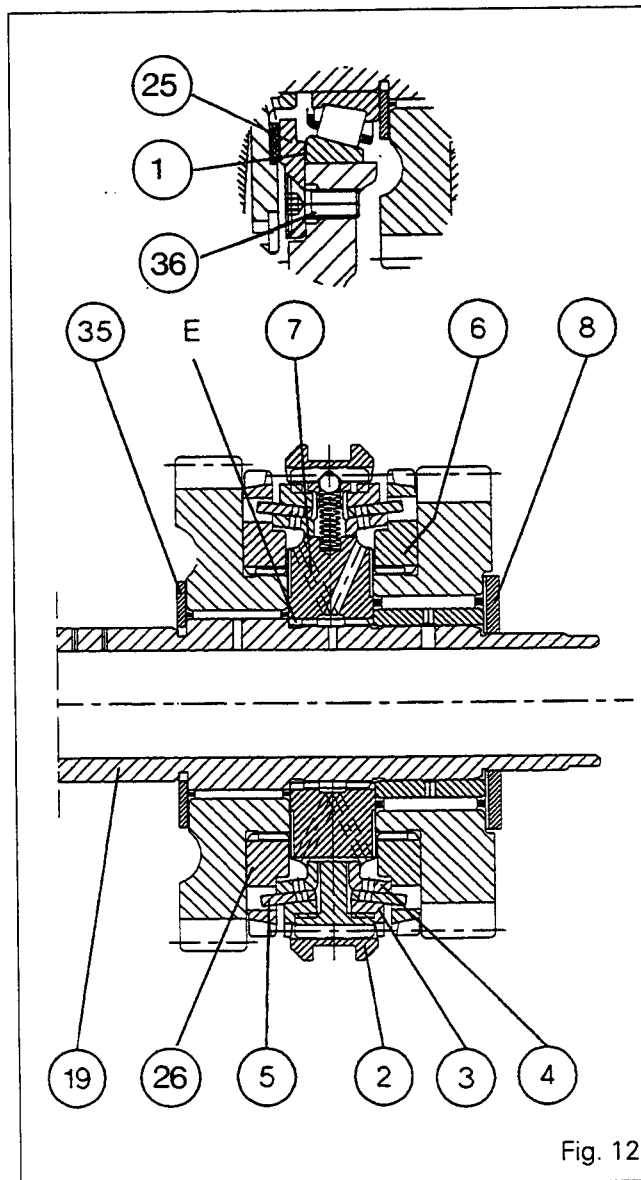

Fig. 12



5B04.10

## 6100 SERIES TRACTORS

**Gearbox - Reverse shuttle****Reassembly**

71. Carry out the disassembly and refitting operations in the reverse order.

**Adjusting the reverse selector (Fig. 13).**

72. Position the selector (33) to neutral. Fit tool 3378054M1 (See Part F) and tighten with bolts «V». Coat the screws (34) with Loctite 221. Bring face «F» of the selector into contact with the tool by means of screws (34).

**Note: The principle for adjusting the screws (34) is identical to that for the version with mechanically operated reverse shuttle.**

**Special point**

The finger «D» on the selector (Fig. 13) moves a link connected to the position sensor fitted on the selector cover (See Section 5C02).

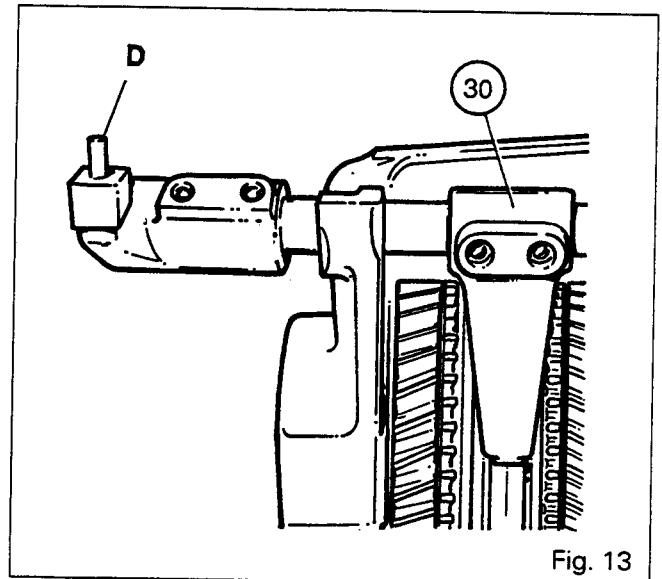

Fig. 13

**H. Speedshift version (Fig. 14)**

On the Speedshift version reverse shuttle, the secondary shaft (19) is supported by two ball bearings (41) and (42).

This installation requires different shimming of the shaft (19). The principle and operation remain identical to those described for the mechanically controlled reverse shuttle.

73. Remove the planetary carrier assembly (50) (See Section 5B02).

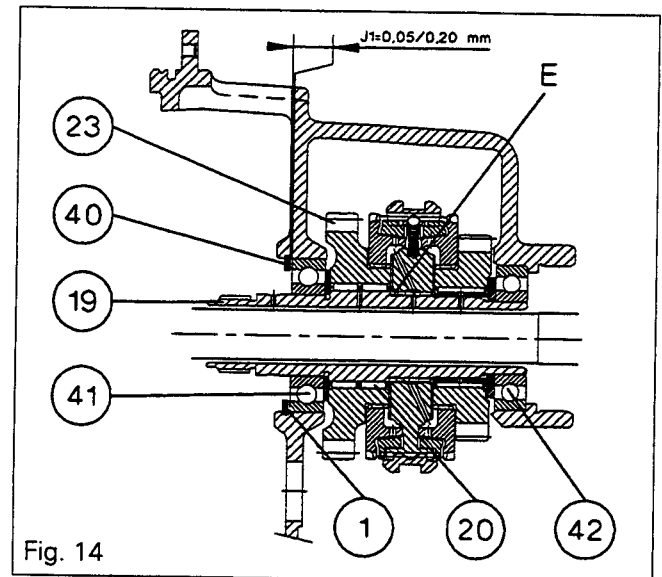

Fig. 14

**Special points (Fig. 14)**

- The circlip (40) replaces the locking plate (25).
- Gear (23) is supported by a bearing (20) comprising two rows of needle rollers.
- Check that the splines on the shaft (19) are engaged with those of the synchromesh. Fit the shaft, with the shoulder «E» pressed against the synchromesh, using a press and a suitable fixture fitted on the inner housing of the bearing (42).
- Shim to obtain a play of  $J1 = 0.05 / 0.20$  mm.





**Gearbox - Mechanical control selector cover** 5C01.1

*5 C01 Selector cover (Mechanical control)*

CONTENTS

-	<b>General</b> _____	<b>2</b>
-	<b>Operation</b> _____	<b>2</b>
A.	<b>Removal</b> _____	<b>6</b>
B.	<b>Disassembly</b> _____	<b>6</b>
C.	<b>Reassembly</b> _____	<b>6</b>
D.	<b>Refitting</b> _____	<b>7</b>
E.	<b>Adjustment of sleeves on levers</b> _____	<b>7</b>



## 6100 SERIES TRACTORS



### 5C01.2 Gearbox - Mechanical control selector cover

#### General

The mechanical control selector cover fitted on the right-hand side of the gearbox housing has two separate levers each of which performs one of two different functions :

- Front lever : This lever controls the reverse shuttle.
- Rear lever : This lever selects the four basic speeds and the two Hare/Tortoise (Hi-Lo) ratios.

#### Operation

##### Forward/Reverse lever

The forward/reverse shuttle is operated when the lever (23) is pushed forwards (reverse) or backwards (forward). When the lever (23) is moved forwards or backwards, it turns the shaft (53) which is secured to the U-arm (54). The index on the U-arm moves the selector (S).

##### Speed lever

##### Selecting 1st/2nd gears

When the lever (12) is pushed, the arm (36) is engaged in the 1st and 2nd speed fork, moving lock (V) which prevents any movement of the 3rd and 4th speed fork.

1st gear is then obtained by moving the lever forwards and 2nd is obtained by moving it back.

##### Selecting 3rd/4th gears

In this configuration, the gear lever (12) is in the intermediate position. The arm (36), which is secured to the lever (12), is engaged in the 3rd and 4th speed fork and lock (V) prevents any movement of the 1st and 2nd speed fork.

3rd gear is then obtained by moving the lever forwards and 4th is obtained by moving it back.

##### Hare/Tortoise function

The Hare/Tortoise position (Hi-Lo) is obtained in the neutral position by pulling the lever (12). The arm (36) moves the lock (V) which applies pressure on switch (1) controlling the Hare/Tortoise solenoid valve via the Autotronic system.

#### List of parts

(1) Switch	(20) Pin	(40) Cup
(2) Seal	(21) Ball	(41) Cup
(3) Temperature gauge	(22) Pin	(42) Spring
(4) Bolt	(23) Reverse lever	(43) Dowel pin
(5) Bolt	(24) Lug	(44) Bolt
(6) Support bracket	(25) Cotter pin	(45) Bolt
(7) Pin	(26) Washer	(46) Bracket
(8) Ball	(27) Ball	(47) Bolt
(9) Dust cover	(28) Pin	(48) Dowel pin
(10) Link	(29) Bolt	(49) Dust cover
(11) Pin	(30) Bolt	/50\ Seal
(12) Gear lever	(31) Support bracket	(51) Dust cover
(13) Pin	(32) Link	(52) Set screw
(14) Ball	(33) Bolt	(53) Shaft
(15) Set screw	(34) Bolt	(54) Arm
(16) Dust cover	(35) Rack	(55) Set screw
(17) Washer	(36) Arm	(56) Cover
(18) Cotter pin	/37\ Seal	(57) Nut
(19) Elbow union	(38) Cup	
	(39) Spring	



# 6100 SERIES TRACTORS



## Gearbox - Mechanical control selector cover

5C01.3

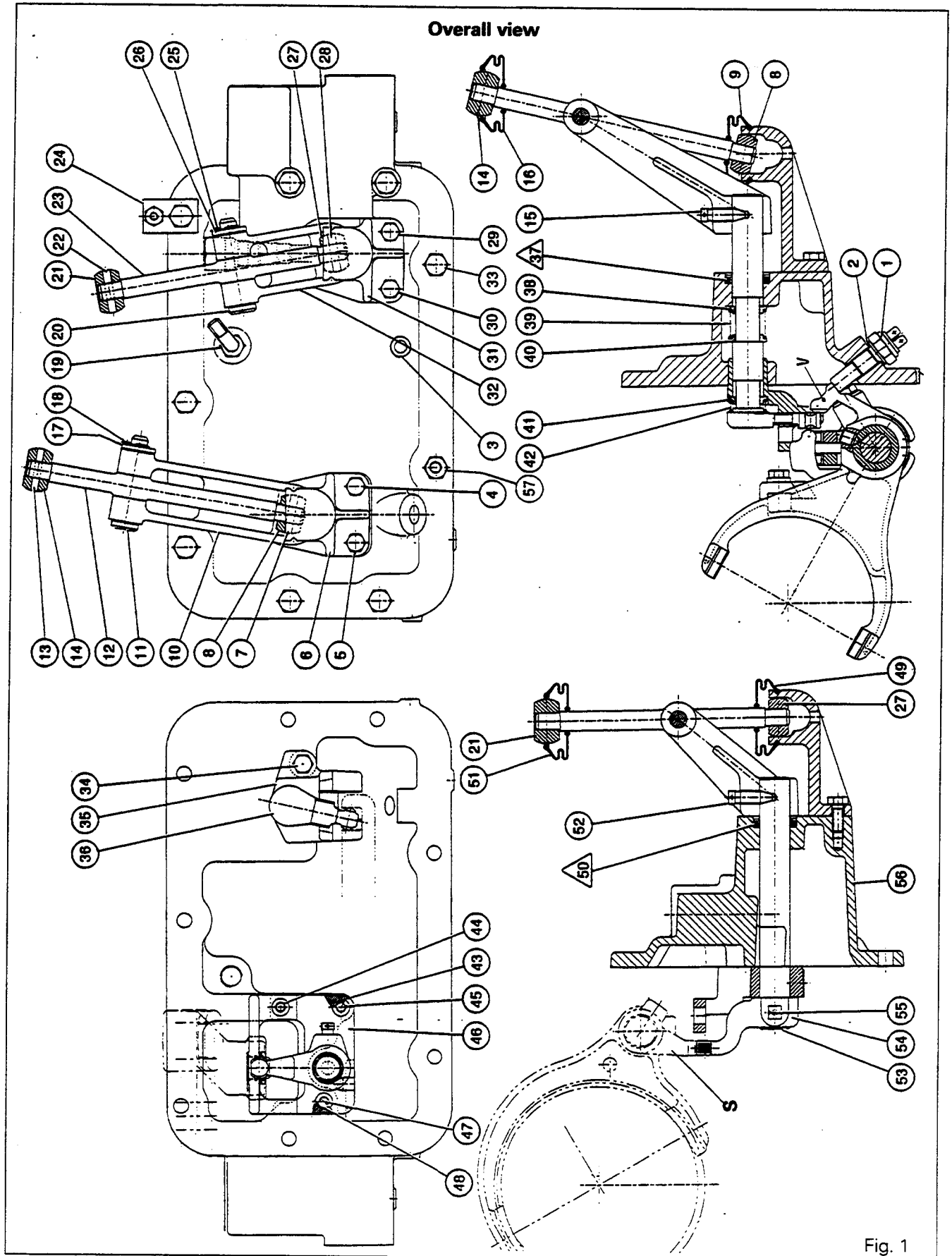

Fig. 1



# 6100 SERIES TRACTORS



## 5C01.4 Gearbox - Mechanical control selector cover

Exploded view

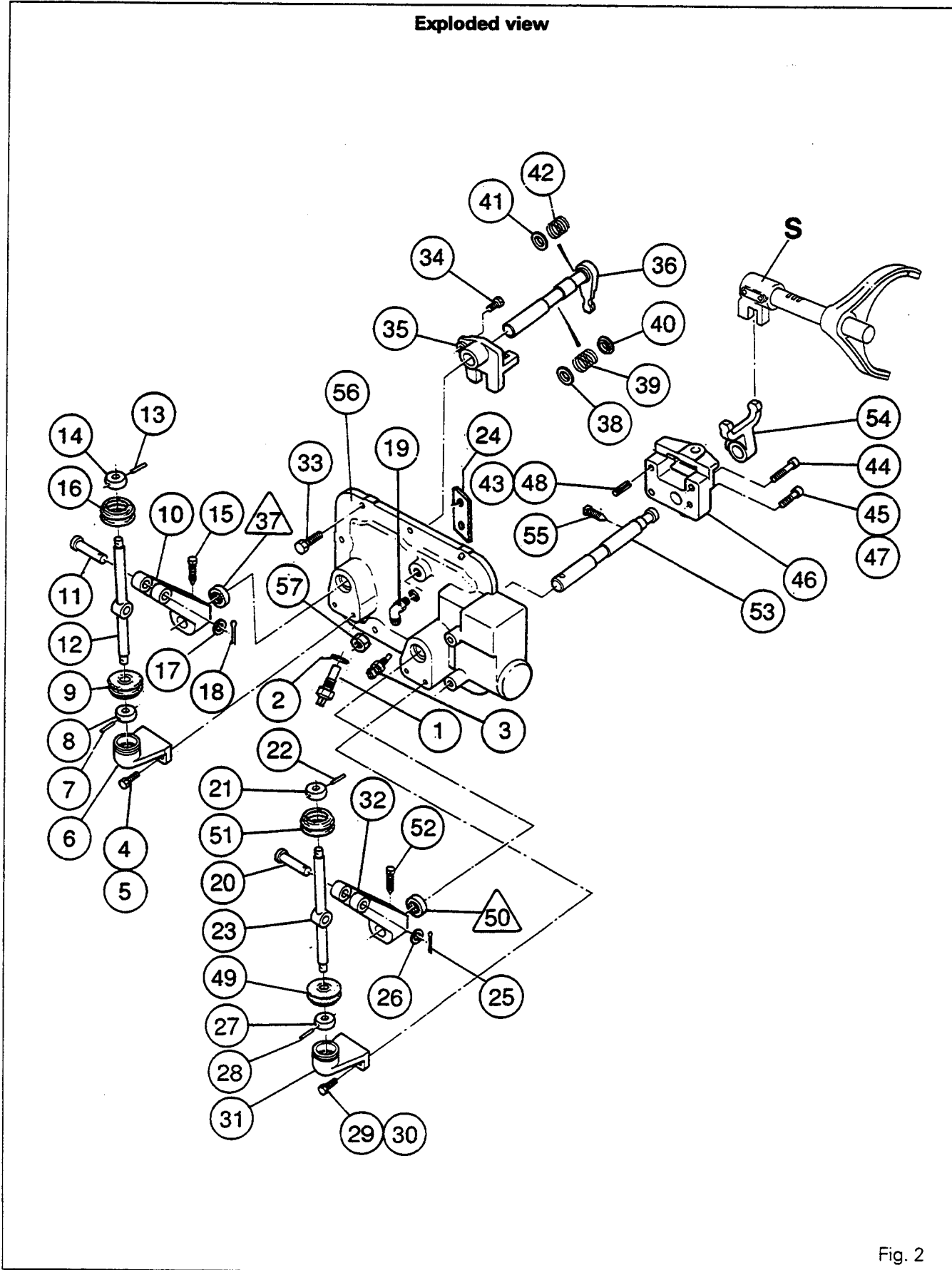

Fig. 2



# Gearbox - Mechanical control selector cover 5C01.5

### Hare position

Solenoid valve E, which is mounted at the bottom of the RH cover ( chapter 9I01) (Fig. 3), opens and feeds hydraulic oil to chamber (a) situated at the rear of piston (13) (Fig. 9). The piston moves forward and applies pressure to fork (20).

The oil contained in chamber (b) is forced into the Hare duct and returns to the 17 bar circuit.

### Tortoise position

Switch (1) is again actuated via the gear lever and this causes the solenoid valve to close and the pressure in chamber (a) to drop. Piston (13) moves back under the prompting of the 17 bar pressure applied to its annular face.

The oil contained in chamber (a) is returned to the housing via the Hare duct and solenoid valve E.

### Hare/Tortoise locking

Slider (18) secured to fork (20) is facing lock (22), which prevents any accidental movement of fork (20) both in the Hare position (Fig. 4) and in the Tortoise position (Fig. 5).

The configuration of lock (22) is such that the slider and fork assembly is only released if the gear lever is pulled to select either the Hare position or the Tortoise position.

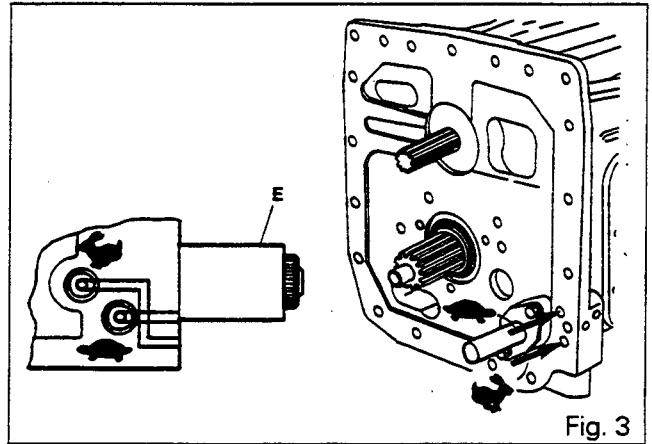

Fig. 3

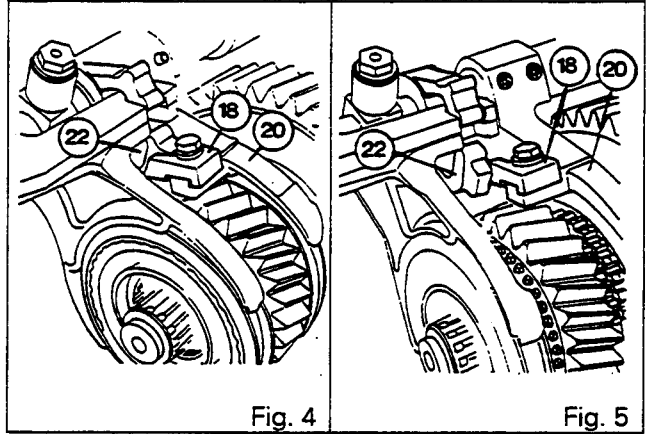

Fig. 4

Fig. 5

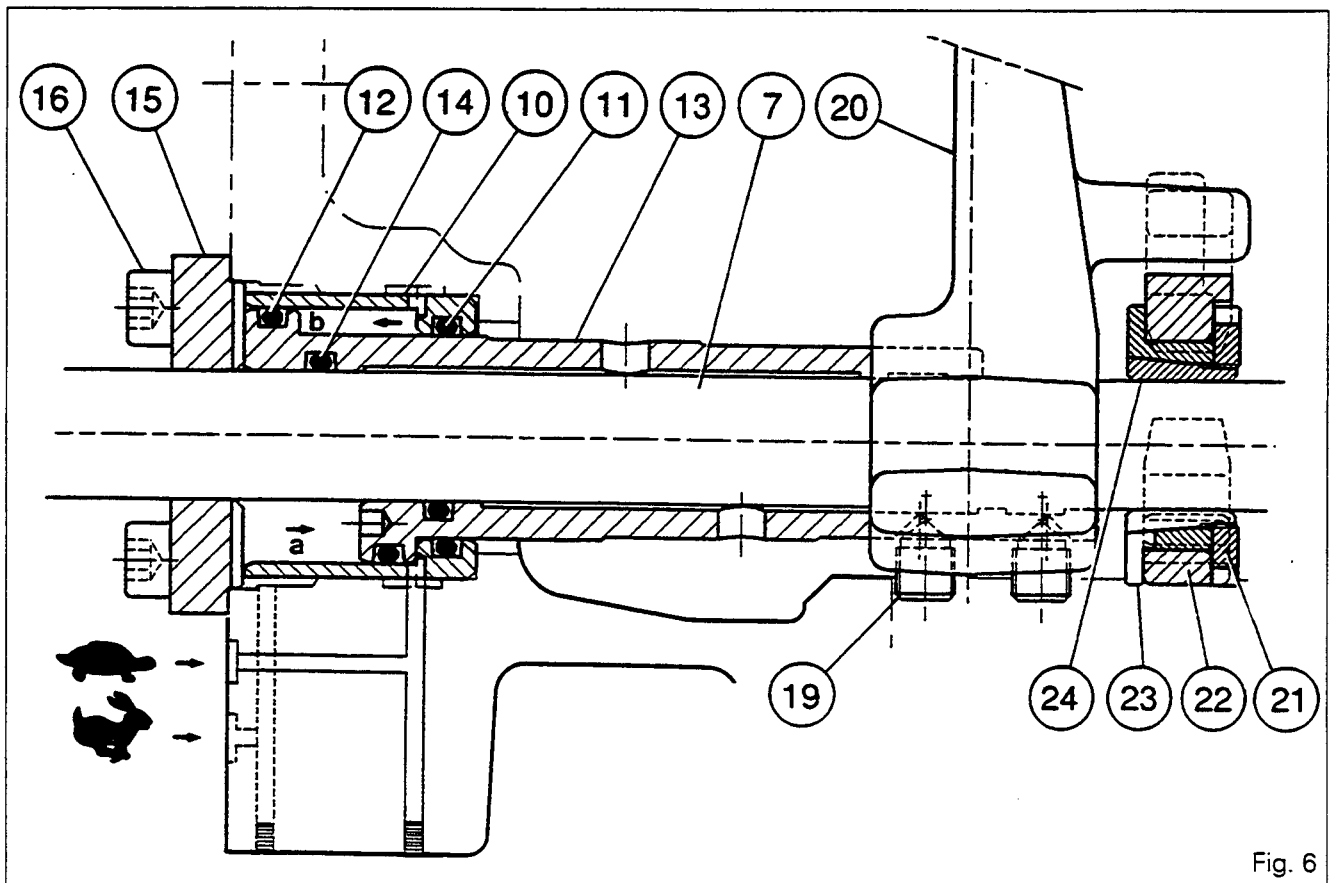

Fig. 6



## 6100 SERIES TRACTORS



### 5C01.6 Gearbox - Mechanical control selector cover

#### A . Removal

1. Immobilise the tractor. Fit wedging block under the left-hand rear wheel.
2. Apply the handbrake.
3. Fit chock between the frame and the front axle.
4. Drain the oil from the gearbox only.
5. Raise the rear right-hand side of the tractor with a trolley jack.
6. Install an axle stand and remove the wheel.
7. Remove the footstep (if necessary).  
Remove the guard, the Dynashift guard and the wet clutch valve support (if fitted).
8. Take out the cotter pins (18) and (25), washers (17) and (26). Remove pins (11) and (20). Lift the dust covers (49) (51) and (9) (16). Remove the reversing lever (23) and gear lever (12) and mark their positions (Fig. 3).
9. Disconnect the wiring harnesses from the switch (1) and temperature gauge (3) (if fitted) (Fig. 7).
10. Disconnect the control linkage on gearboxes equipped with creeper gears.
11. Remove the nut (57) and bolts (33) and mark the position of the earth wire lug (24). On creeper-type gearboxes, remove the control cable support bracket (1) (Fig. 8).
12. Remove the cover (56).

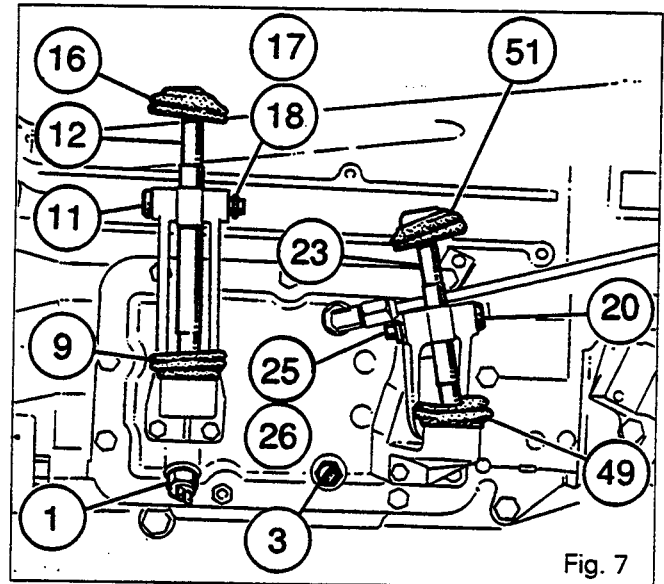

Fig. 7

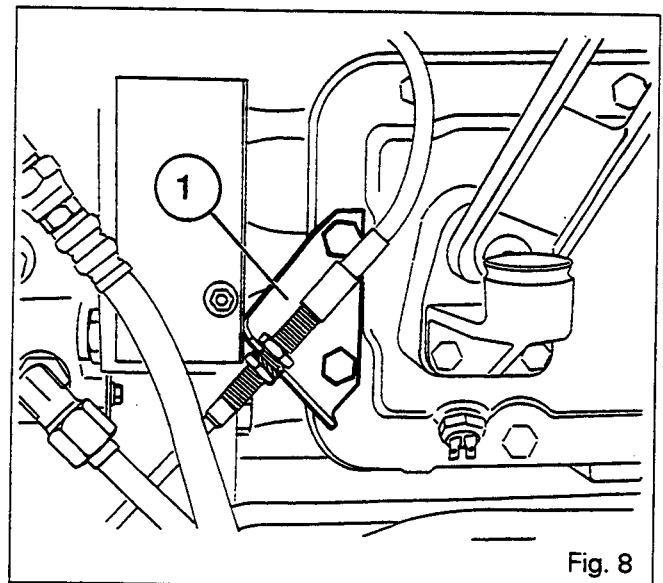

Fig. 8

#### B . Removal

13. Install the cover in a vice.
14. Take out bolts (29) (30) and (4) (5). remove the supports (6) and (31).
15. Remove set screws (15) and (52). Remove the links (10) and (32).
16. Remove bolt (55). Withdraw shaft (53) and remove the reversing control U-arm (54).
17. Remove bolts (44) (45) and (47).
18. Remove the bracket (46).
19. Extract the dowel pins (43) (48) from the cover.
20. Remove bolt (34). Remove the gear control cover.
21. Remove the cups (38) and (40), and spring (39).
22. Separate the arm (36) from rack (35). Remove the cup (41) and spring (42) from the arm (36).
23. Remove the Hare/Tortoise switch (1), seal (2), union (19) and temperature gauge (3) (if fitted).
24. Remove seals /37\ and /50\.

#### C . Reassembly

25. Clean the mating face on the cover (56). Apply Loctite 542 on the outer circumference of seals /37\ and /50\ and fit them fully home in the shoulder of the cover.
26. Fit the dowel pins (43) and (58) in the cover. Install the bracket (46). Reinstall the bolts (44) (45) and (47), and tighten them to a torque of 25 - 35 Nm. Refit the U-arm (54) and refit the shaft (53) from the inside of the cover. Be careful not to damage the lip of seal /50\.
- Install the set screw (55) and tighten it to a torque of 28 - 43 Nm.
27. Refit the cup (41) and spring (42) on arm (36). Assemble the arm with the rack (35).



## Gearbox - Mechanical control selector cover 5C01.7

28. Reinstall the spring (39) and cups (38) and (40).
29. Refit the gear control assembly and bolt (34) after coating it with Loctite 270. Tighten to a torque of 25 - 35 Nm.

**Note :** *Be careful not to damage the lip of seal /37L.*

30. Reinstall the union (19), the temperature probe (3) fitted with its seal, the Hare/Tortoise switch (1) and its seal (2).
31. Refit links (10) and (32). Fit the set screws (15) and (52).
32. Refit the support brackets (6) and (31). Fit bolts (29) (30) and (4) (5).

### D . Refitting

33. Clean the mating face on the cover (56).
34. Set the reversing selector, and the 1st, 2nd, 3rd and 4th gear forks to the neutral position. Move the lock V towards the opening of the selector cover. Check that bolt (1) is present (see Fig. 9).
35. Apply a sealing compound on the mating face of the gearbox housing.
36. Position the gear lever pointing towards the right. Set the reversing lever to the neutral position.
37. Position the cover on the gearbox, making sure that the levers are correctly positioned in the selector mechanisms.
38. Fit the earth wire lug (24), bolts (33) and nut (57). Tighten to a torque of 50 - 70 Nm.  
**Note :** *For gearboxes equipped with creeper gears, fit the cable support (1) (Fig. 8).*
39. Connect up the control linkage on gearboxes equipped with creeper gears.
40. Reconnect the wiring harnesses to the Hare/Tortoise switch (1) and on the temperature probe (3).
41. Refit the reversing lever (23) and gear lever (12).
42. Reinstall pins (11) and (20). Reinstall the washers and pins. Position the dust covers (Fig. 7).
43. Reinstall the Dynashift accumulator (if fitted), the clutch valve (if fitted) and its support. Refit the guard.
44. Refit the footstep (if it was removed).
45. Reinstall the wheel.
46. Remove the axle stand and the trolley jack. Tighten the wheel nuts to a torque of 400 - 450 Nm.
47. Carry out procedures 1 to 4 in reverse order.
48. Carry out a road test on the controls for :
  - the reverse shuttle, gears, Hare/Tortoise range, creeper gears (if fitted), Dynashift speeds A, B, C, D and the electro-hydraulic clutch.
  - Check the mating face on the cover and hydraulic unions for leaks.

### E . Adjusting the sleeves on levers

**Note:** *If an adjustment or replacement is necessary, lightly coat the inside of each sleeve with "Anti-Seize" grease or equivalent.*

49. Set the reversing and gear levers to the neutral position.
50. Unlock nuts (1). Adjust the sleeves (2) so as to obtain a dimension X between the base of the sleeve and shoulder "E" on each lever (see Fig. 10). Tighten the nuts to a torque of 50 Nm and position the dust cover (3).

X = 40 mm for all types except MF 6190 tractors  
= 70 mm for MF 6190 tractors.

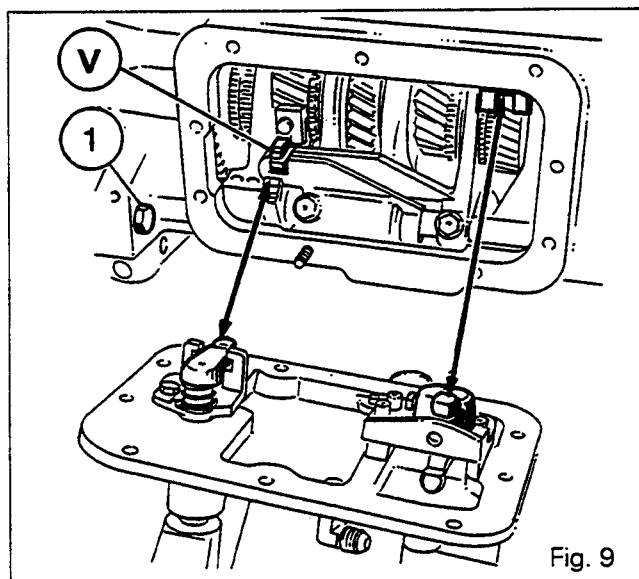

Fig. 9

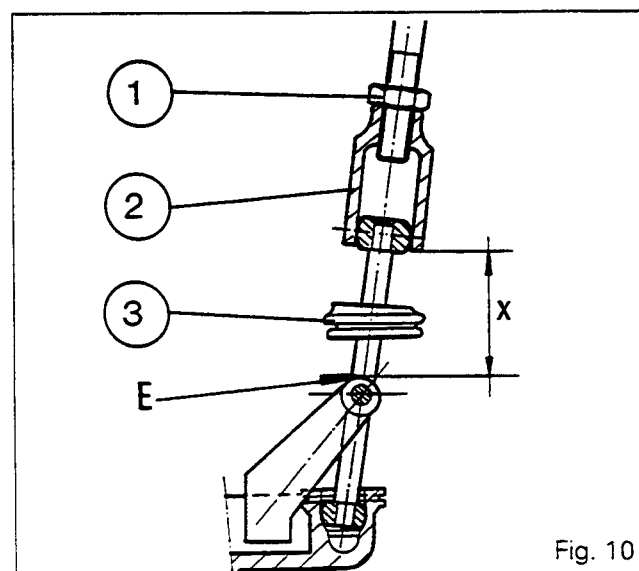

Fig. 10







**Gearbox** - *Electrohydraulic selector*

5C02.1

5 C02 *Electrohydraulic selector cover*

CONTENTS

-	<b>General - Operation</b> _____	<b>2</b>
A.	<b>Removal - Refitting</b> _____	<b>5</b>
B.	<b>Disassembly - Reassembly</b> _____	<b>6</b>
C.	<b>Adjusting the sleeve on gear lever</b> _____	<b>7</b>
D.	<b>Removing and refitting the accumulator</b> _____	<b>7</b>



5C02.2

---

**6100 SERIES TRACTORS**

---

**Gearbox - Electrohydraulic selector**

---

**General**

---

6100 series tractors can be fitted with an electrohydraulically controlled reverse shuttle.

The system comprises:

- a dual synchro cone,
- a fork fitted on the selector rail,
- a piston actuated by the hydraulic system via the 17-bar spool valve which moves the selector rail by means of a selector.

The piston is housed in the selector cover and operated by two solenoid valves equipped with diodes controlled by the Autotronic system.

The solenoid valves are only supplied with power when reverse is engaged.

A sensor attached to the outside of the cover signals the position of the piston to the Autotronic system.

A sealed chamber is fitted at each end of the piston.

The front chamber is closed by a removable plug to allow the piston to be removed.

---

**Operation**

---

**Forward motion**

The front solenoid valve is power-supplied and pressure is applied on the front face of the piston. The piston moves rearwards to engage the synchro with the forward motion gear. When the piston reaches the engaged position, the solenoid valve is no longer supplied with power and the piston chamber is connected to the return pipe.

**Rearward motion**

The rear solenoid valve is supplied with power and pressure is applied on the rear face of the piston which moves forwards to engage the synchromesh with the reverse motion gear.

---

**List of parts**

- |   |                            |
|---|----------------------------|
| <b>(1)</b> Switch                         | <b>(19)</b> Piston         |
| <b>(2)</b> Seals                          | <b>(20)</b> Link           |
| <b>(3)</b> Reverse solenoid valve         | <b>(21)</b> Seal           |
| <b>(4)</b> Bolt                           | <b>(22)</b> Retaining ring |
| <b>(5)</b> Position sensor                | <b>(23)</b> Coupling       |
| <b>(6)</b> Support bracket                | <b>(24)</b> Lug            |
| <b>(7)</b> Plug                           | <b>(33)</b> Bolt           |
| <b>(8)</b> Bolt                           | <b>(34)</b> Bolt           |
| <b>(9)</b> Coupling                       | <b>(35)</b> Rack           |
| <b>(10)</b> Link                          | <b>(36)</b> Finger         |
| <b>(11)</b> Forward motion solenoid valve | <b>(37)</b> Seal           |
| <b>(12)</b> Lever                         | <b>(38)</b> Cup            |
| <b>(13)</b> Temperature probe             | <b>(39)</b> Spring         |
| <b>(14)</b> Circlip                       | <b>(40)</b> Cup            |
| <b>(15)</b> Bolt                          | <b>(41)</b> Cup            |
| <b>(16)</b> O-ring                        | <b>(42)</b> Spring         |
| <b>(17)</b> Plug                          | <b>(56)</b> Cover          |
| <b>(18)</b> O-rings                       | <b>(57)</b> Nut            |



6100 SERIES TRACTORS

**Gearbox - Electrohydraulic selector**



5C02.3

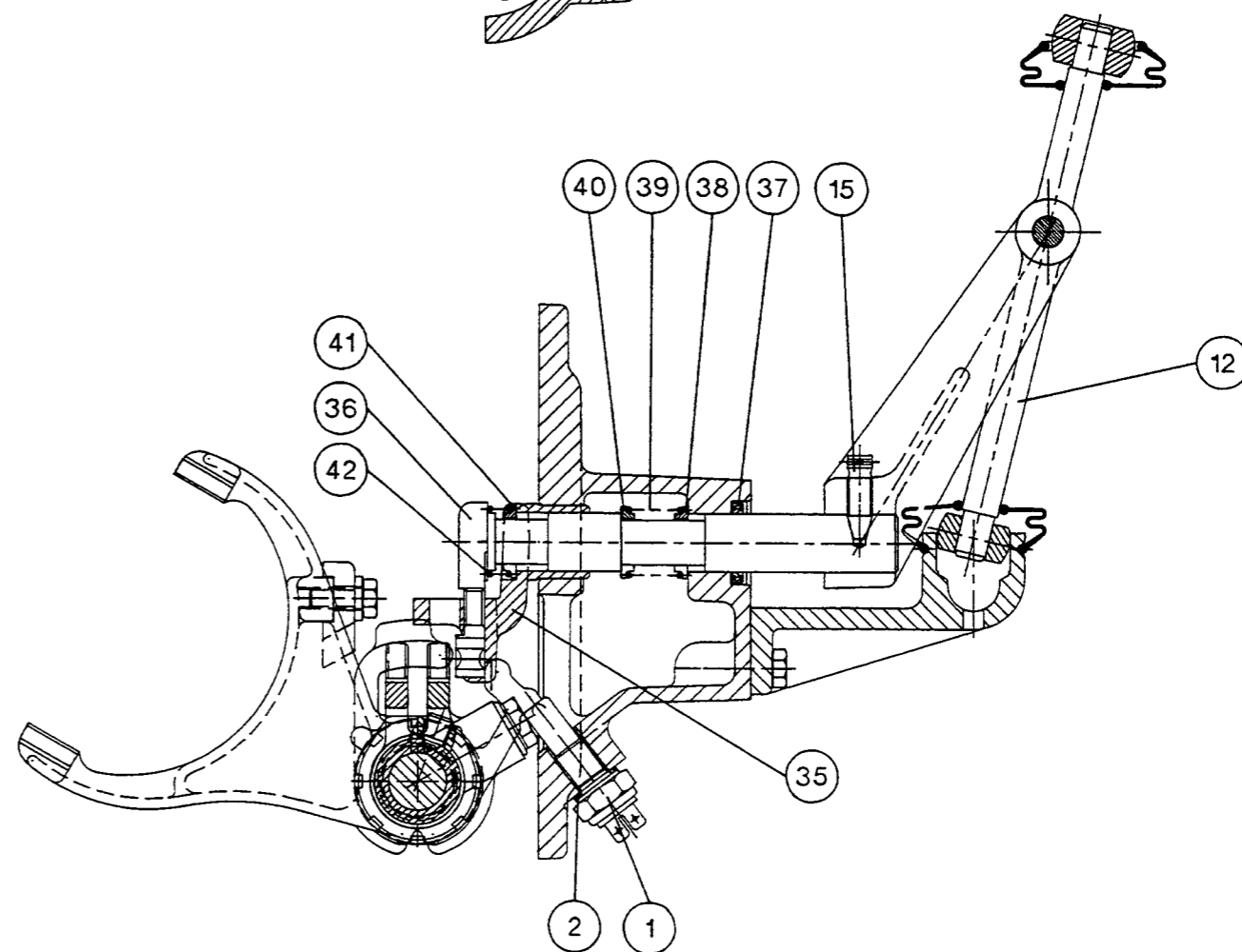
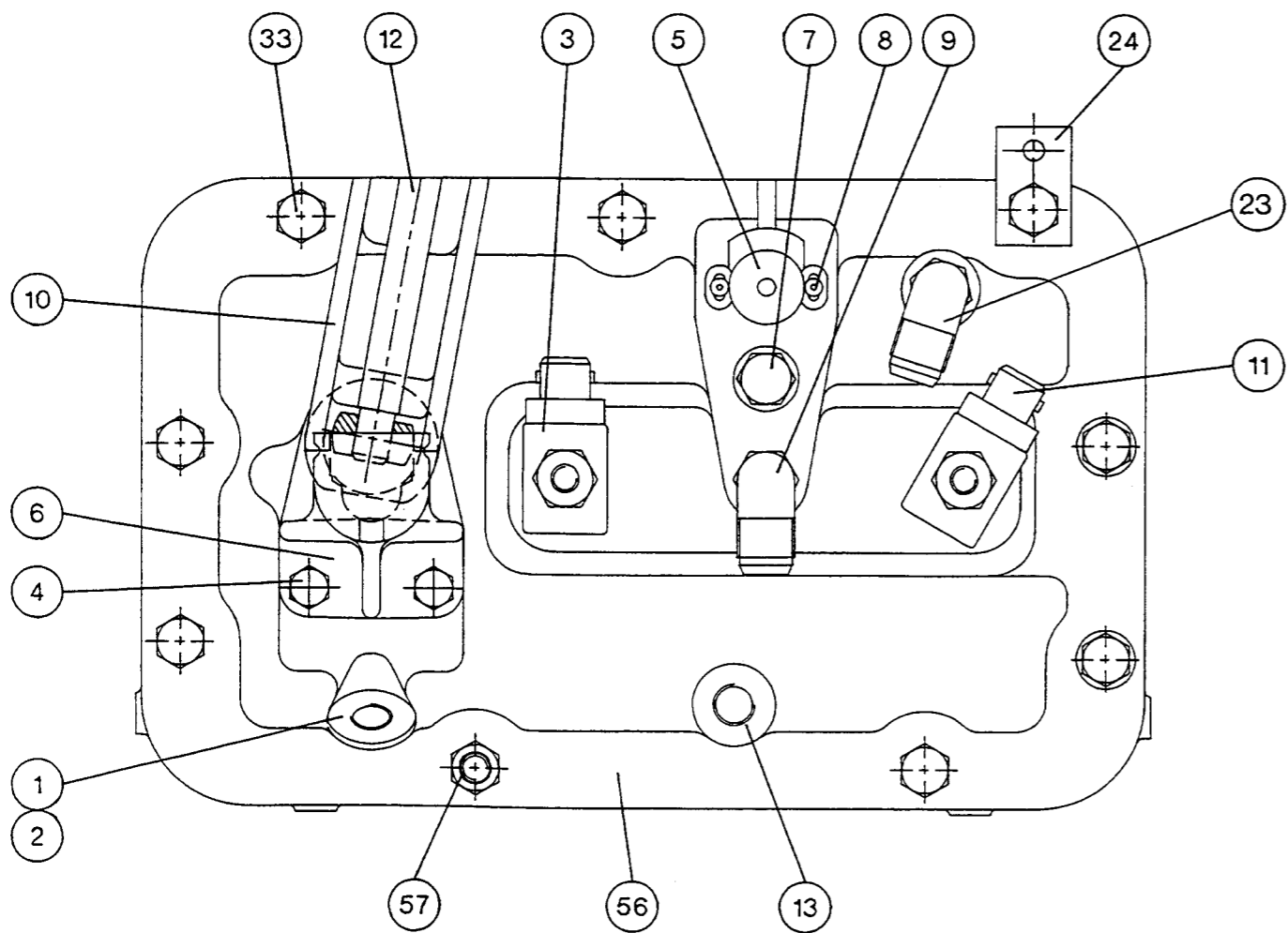
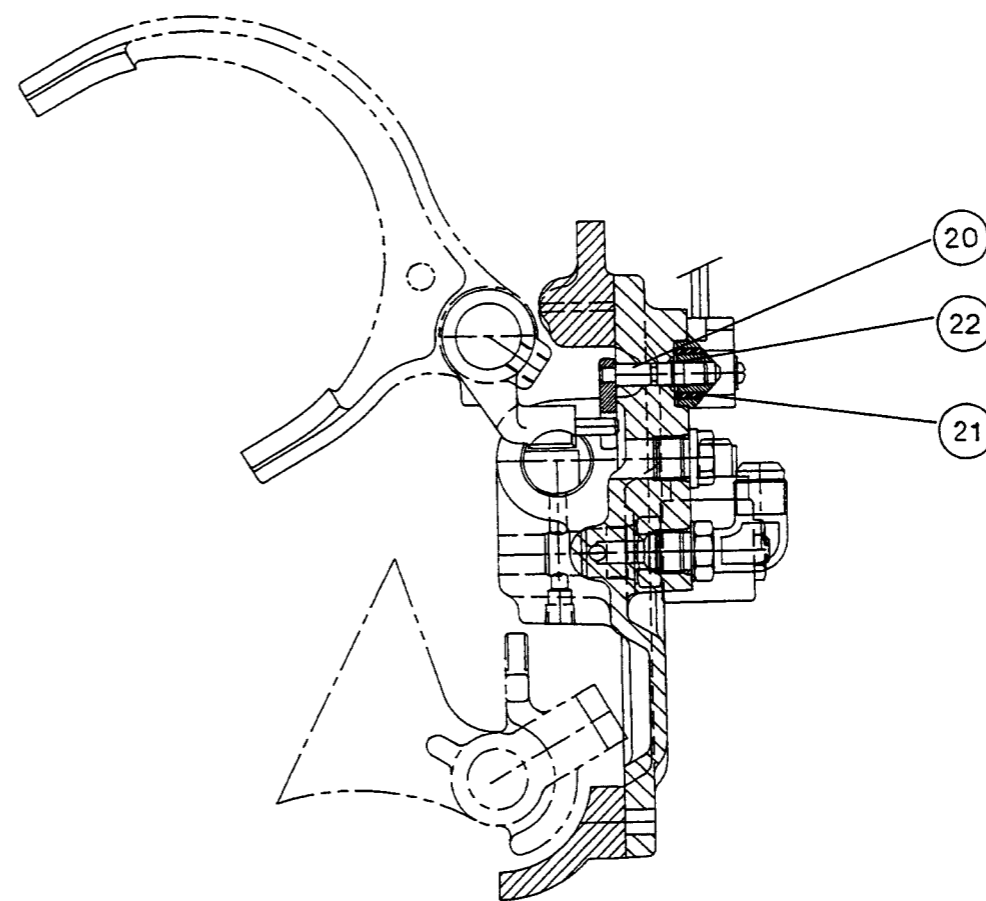
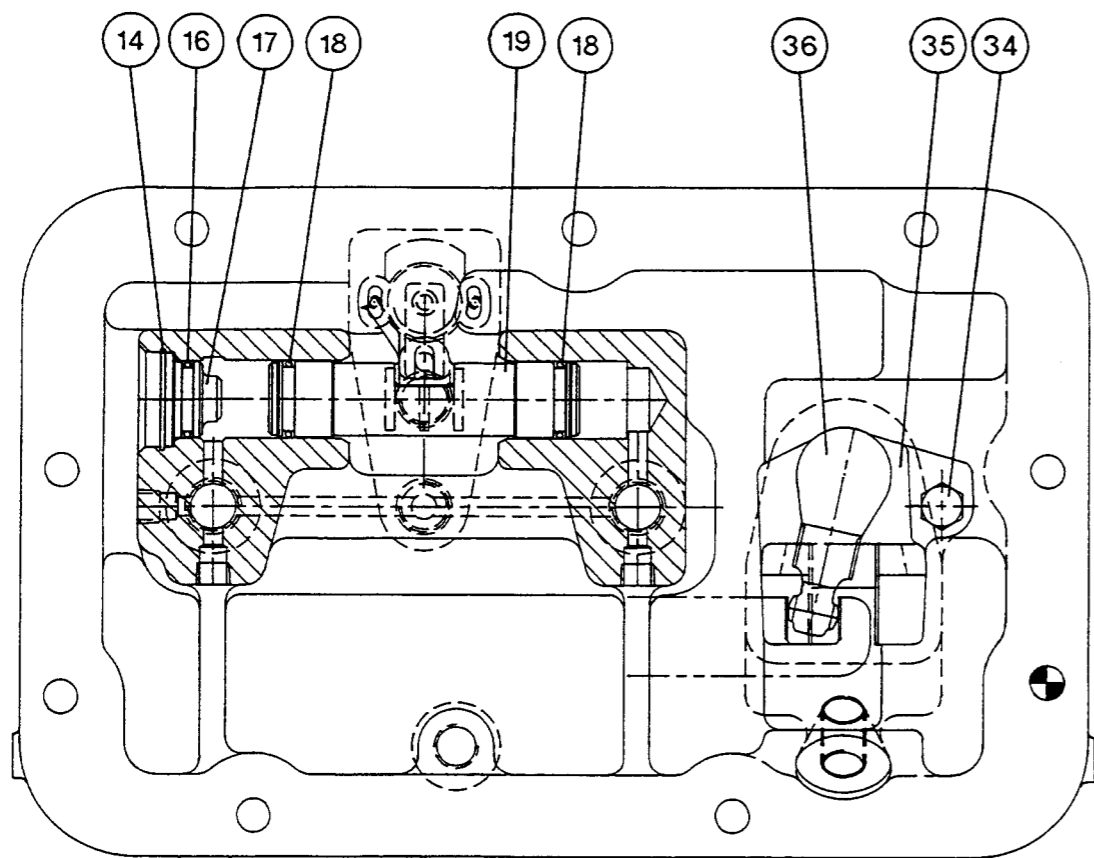



## Gearbox - Electrohydraulic selector

5C02.5

### A. Removal - Refitting

**Note:** To avoid immobilising the tractor in the event of any failure of the hydraulic system (low or no pressure) or electrical failure, the reverse shuttle can be engaged via the inspection port «T» (Fig. 2) using a screwdriver placed in the grooves on the piston (19).

#### Removal

1. Remove the guard.
2. Immobilise the tractor. Remove the wheel, if necessary.
3. Drain the oil from the gearbox.
4. Remove the lever (12).
5. Disconnect the 17-bar and return pipes (if fitted), wiring harnesses (earth, position sensor, solenoid valves, Hare/Tortoise contactors and temperature probe).
6. Detach and remove the cover.

#### Refitting

7. Clean the mating face on the cover and the gearbox.
8. Set the reversing selector, and the 1st-2nd and 3rd-4th gear forks to the neutral position. Move the lock «V» towards the opening of the selector cover (see Fig. 1).
9. Apply a sealing compound on the mating face on the gearbox housing.
10. Position the notch on the piston (19) pointing upwards and line it up with the centre of the inspection port «T». Position the finger (36) pointing to the right (Fig. 1).
11. Position the cover on the gearbox, making sure that the finger is engaged in the lock.
12. Using a screwdriver, through the inspection port «T» (Fig. 2), position the piston in the selector «S» and align the notch in the link (20) with the finger «D» on the selector (Fig. 1). Fit the cover on the gearbox.
13. Fit the earth wire lug (24) and the creeper gearshift control support bracket (if fitted). Tighten the bolts (33) and nut (57) to a torque of 50 to 70 Nm.
14. Reconnect the pipes and wiring harnesses.
15. Refit the gear lever and the wheel (if removed) and tighten the wheel nuts to a torque of 400 to 450 Nm.
16. Top up the oil in the centre housing.

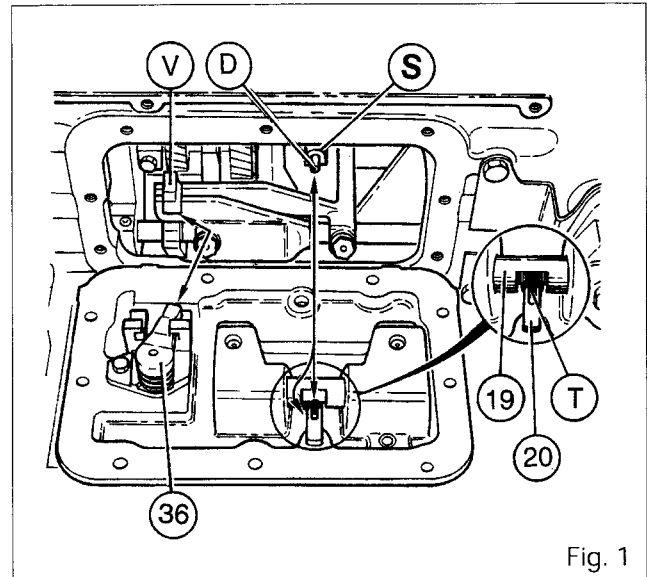

Fig. 1

17. Reset the reverse shuttle electrohydraulic control system. See section 11C02.
18. Carry out a road test on the following controls: reverse shuttle - gearshift, Hare/Tortoise range - creeper gears (if fitted) and Dynashift speeds A, B, C, D (according to version).
19. Check the mating face on the cover and hydraulic unions for leaks.
20. Reinstall the guard.

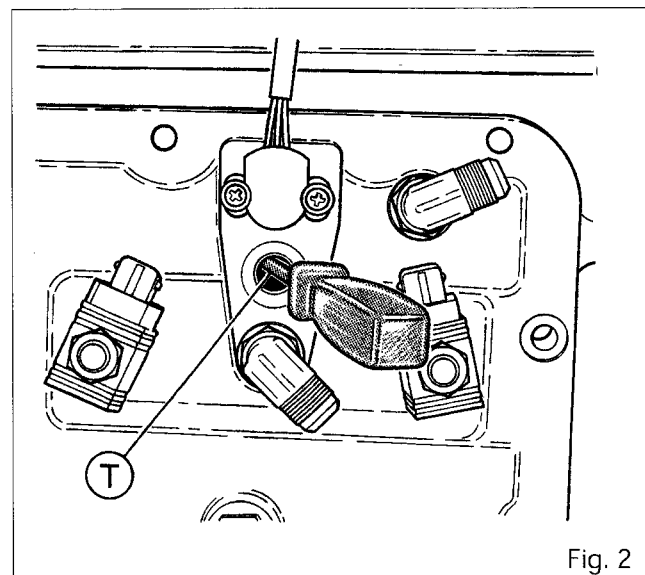

Fig. 2



5C02.6

## Gearbox - Electrohydraulic selector

### B. Disassembly - Reassembly

#### Disassembly

21. Remove the bolts (8). Remove the position sensor (5) and its seal. Remove the solenoid valves (3) and (11), and the couplings (9) and (23). Dismantle the Hare/Tortoise contactor (1) and remove the seals (2) and temperature probe (13) (if fitted) (Fig. 3).
22. If necessary, remove the retaining ring (22). Remove link (20) and the seal (21). Remove link (10) (Fig. 3).
23. Remove the bolt (34) (Fig. 4). Remove the gearshift control assembly.
24. Remove the cups (38) and (40), and the spring (39).
25. Separate the finger (36) from the rack (35). Remove the cup (41) and the spring (42).
26. Extract the seal (37).
27. Remove the circlip (14) and the plug (17). Take out the piston (19) (Fig. 4).

#### Reassembly

28. Clean the mating face on the cover.
29. Check that the channels in the cover are not blocked.
30. Fit the lubricated seals (18) on the piston (19) and position it in the cover. Remove the plug (17) equipped with the O-ring (16). Position the circlip (14) (Fig. 5).
31. Check that the piston moves correctly.
32. Coat the outside diameter of the seal (37) with Loctite 542 and fit it fully home in the shoulder.
33. Reinstall the cup (41) and the spring (42) on the finger (36). Assemble the finger with the rack (35).
34. Reinstall the spring (39) and the cups (38) and (40).
35. Refit the gearshift control assembly without damaging the seal (37). Fit the bolt (34) after coating it with Loctite 270. Tighten to a torque of 25 to 35 Nm.
36. Refit link (10). Fit the bolt (15) and tighten to a torque of 28 to 43 Nm. Refit the support bracket (6) and the bolts (4), tightened to a torque of 25 to 35 Nm.
37. If it was removed, refit link (20) with a new seal (21) and the retaining ring (22).

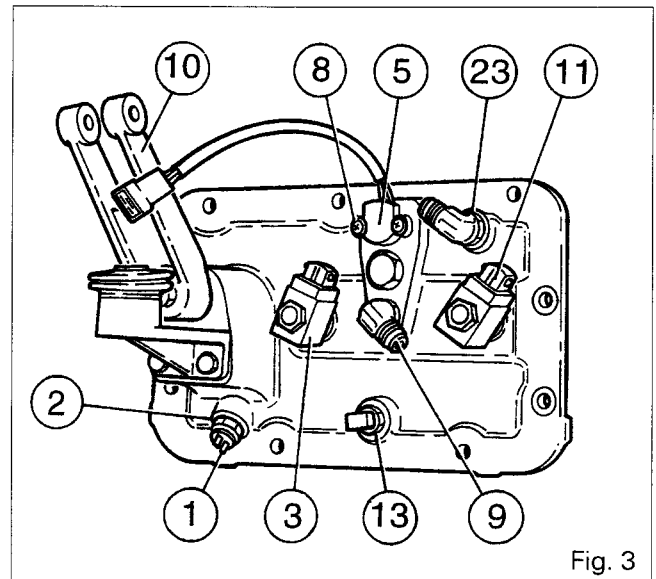

Fig. 3

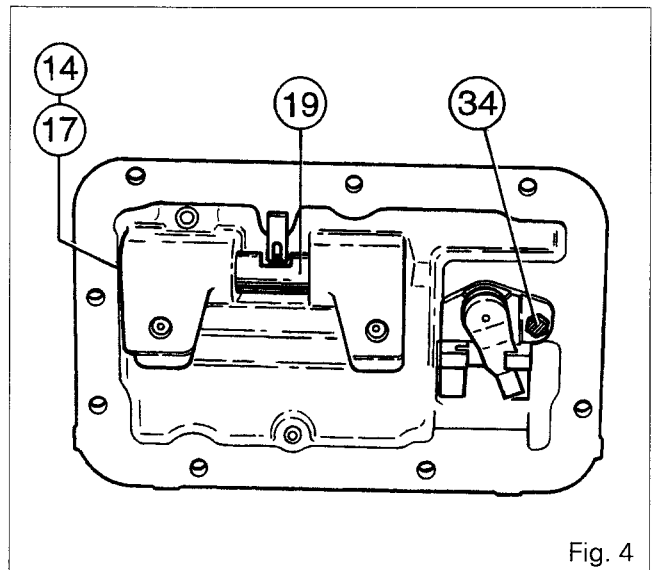

Fig. 4

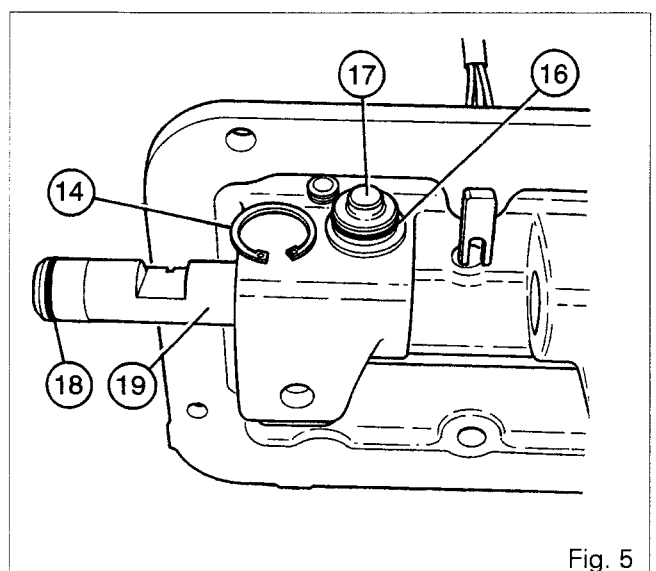

Fig. 5



## Gearbox - Electrohydraulic selector

38. Reinstall the temperature probe (if fitted), the Hare/Tortoise contactor with seals (2), the couplings (9) and (23), and the solenoid valves (3) and (11), tightened to a torque of 20 Nm.

**Note: The solenoid valves are equipped with diodes.**

39. Fit the position sensor (5) and its seal, and the attaching bolts (8) positioned in the centre of the elongated holes (Fig. 6).

### C. Adjusting the sleeve on gear lever

**Note: If an adjustment or replacement is necessary, lightly coat the inside of the sleeve with «Anti-Seize» grease or equivalent.**

40. Set the gear lever to the neutral position.  
 41. Unlock nut (1). Adjust the sleeve (2) so as to obtain a dimension X between the base of the sleeve and shoulder «E» on the lever (see Fig. 7).  
 42. Tighten the nut to a torque of 50 Nm and position the dust cover (3).  
 X = 40 mm for all types.

### D. Removing and refitting the accumulator (Figures 8 and 10)

As from serial number D205006 (Dynashift) and D208009 (Speedshift), the tractors are equipped with an accumulator fitted on the outside face of the selector cover (56) to increase the progressive effect of the reverse shuttle.

At each end of piston (19), there is a chamber equipped with a plug (49) fitted with a calibrated hole.

The flow rate to the piston is limited by a restrictor fitted in the coupling (48).

#### Removal

43. Disconnect the hose (45). Remove the accumulator (46) and the calibrated coupling (48). Disconnect the return couplings (43) and (44).

**Note: If servicing work is necessary on the calibrated plugs (49), remove the cover (56), (see § A).**

#### Refitting

44. Carry out procedure 43 in the reverse order.

**Note: If the calibrated plugs were removed, lightly smear them with Loctite 542 or equivalent.**

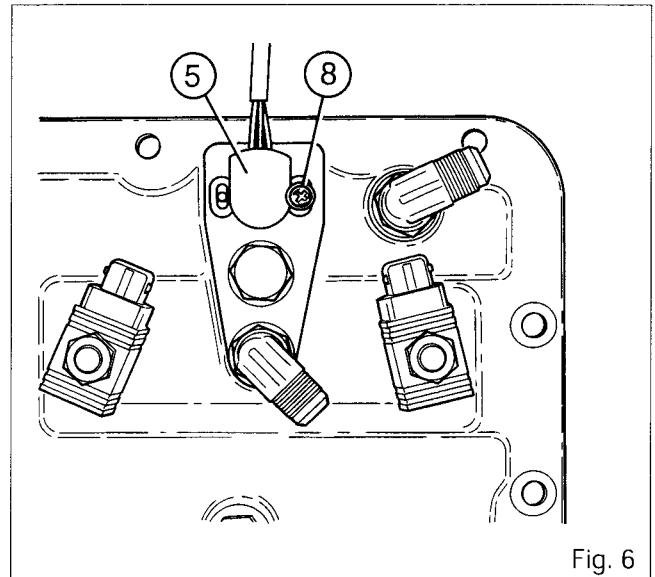

Fig. 6

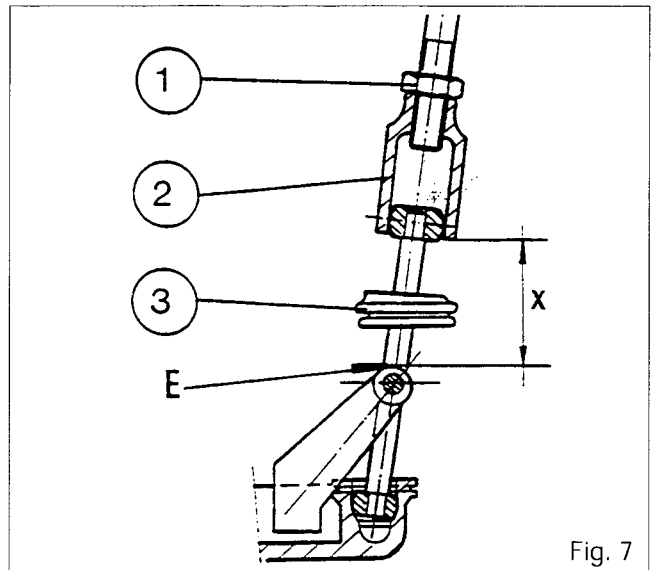

Fig. 7

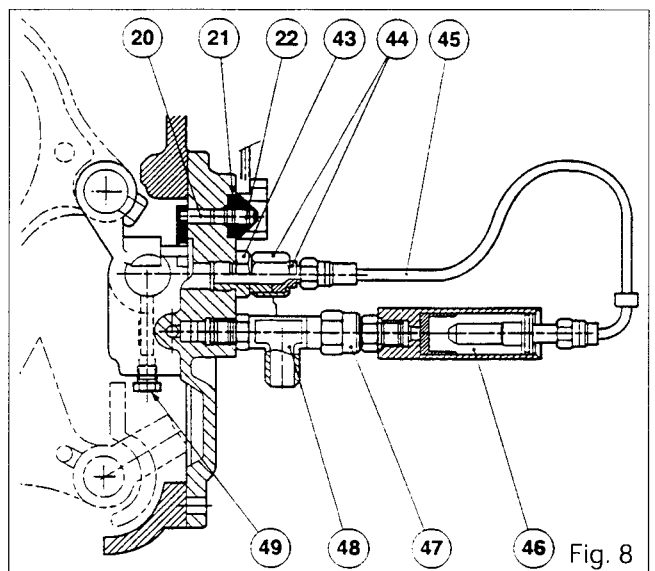

Fig. 8



5C02.8

# Gearbox - Electrohydraulic selector

As from serial number E032053 (Fig. 9), 6100 series tractors are equipped with a new selector cover (56).

This cover is equipped with a machined chamber on its outside face, for the fitting of the accumulator mounted on the cover.

The restrictor limiting the pressure on the piston is fitted in the 17-bar feed port.

### Disassembly

- 45. Remove the circlip (50). Remove the plug (51) fitted with its seal, the spring (52) and the piston (53).

### Reassembly

- 46. Clean the parts and replace any that are faulty. Check that the piston (53) slides freely in the cover.
- 47. Carry out procedure 45 in the reverse order. Check that the circlip (50) is correctly positioned.

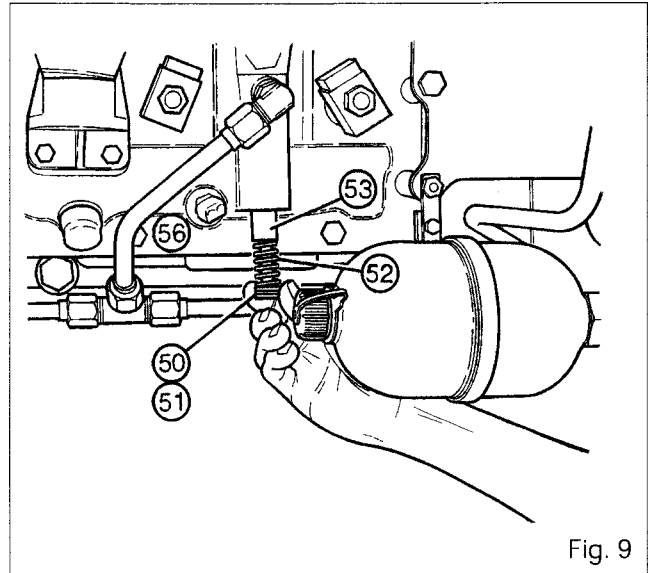

Fig. 9

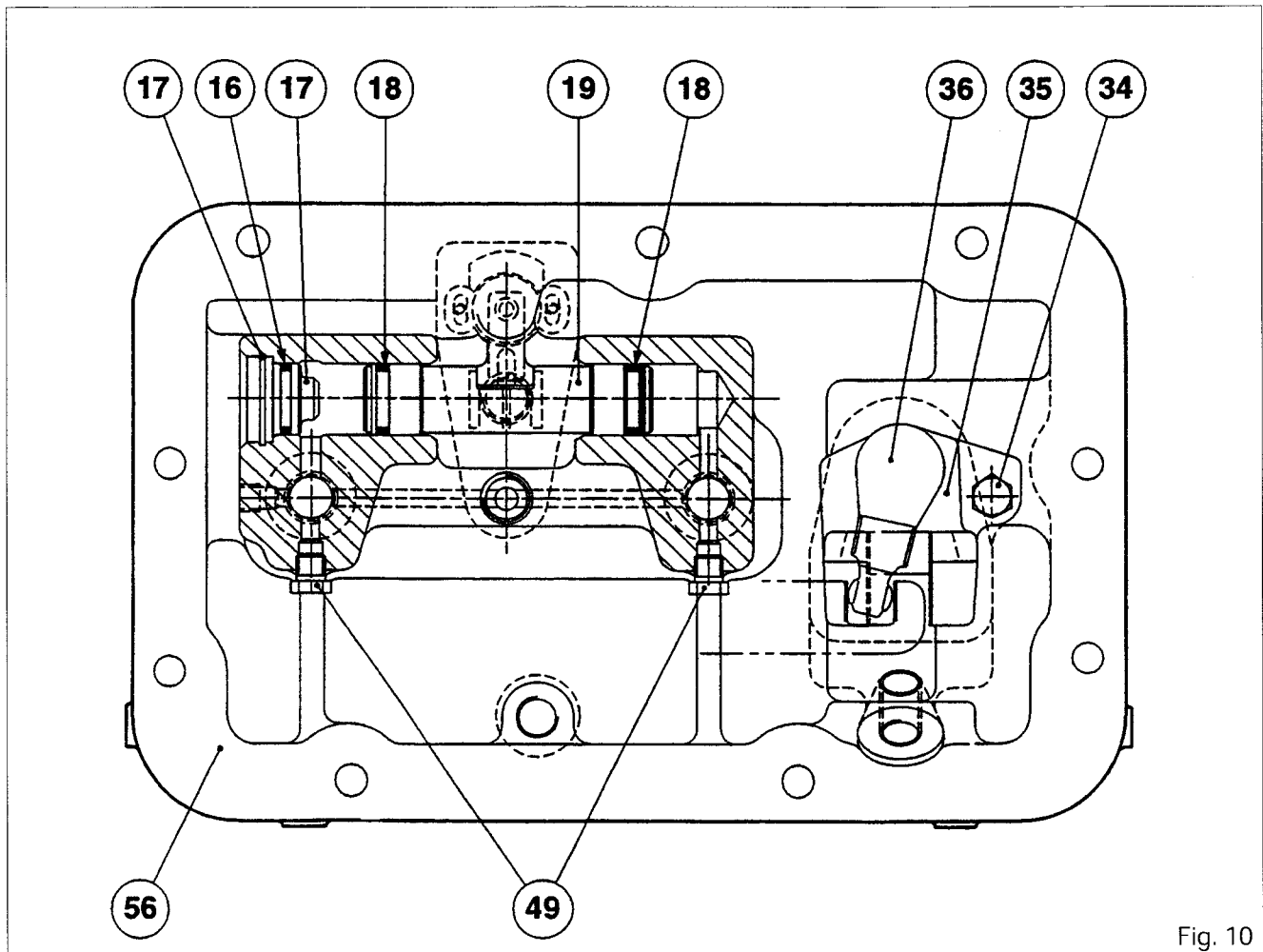

Fig. 10



*5 D01 Selector rail and forks*

CONTENTS

General	_____	2
A. Creeper gear fork	_____	2
B. Hare/Tortoise range fork - Mechanical lock assembly - 1st/2nd/3rd/4th forks - Selector rail	_____	6
C. Service tools	_____	11
D. Selector rail (Heavy Duty gearbox)	_____	12





5D01.2

## 6100 SERIES TRACTORS

**Gearbox - Selector rail and forks****General**

The selector rail (7) which supports the various forks and the mechanical latch assembly is fitted on the right-hand side of the gearbox, on the selector cover side. It crosses the gearbox housing and the Hare/Tortoise range control piston (13). It is secured by means of a setscrew (8). A recess plug (9) blanks the opening at the front end of the rail and a cover (15) blanks the rear end.

The forks for 1st - 2nd gears (5), 3rd - 4th gears (6) and the creeper gears (28) cannot be adjusted (except for locking pressure in the case of creeper gears). The Hare/Tortoise range fork (20) is adjustable.

**A. Creeper gear fork****Disassembly**

1. Disconnect the control cable.
2. Remove the selector cover. See Section 5C01 or 5C02, according to version.
3. Remove the right-hand hydraulic cover. Carry out procedures 2 to 14, in section 9I01.
4. Remove the bolt (1), withdraw the rod (2) to disengage the finger from the fork (Fig. 1).
5. Unscrew the nut (26) and the locking screw (27) on the fork (28).
6. Remove the setscrew (8).
7. Turn the selector rail (7) and drive out the dowel (29) (Figures 2 and 3).

**Note: Take care that the dowel does not fall into the gearbox housing.**

8. Drive out the pin (1) from the coupling sleeve (2) (Fig. 4).

If the pin is inaccessible on 4WD tractors, carry out procedures 9 to 12.

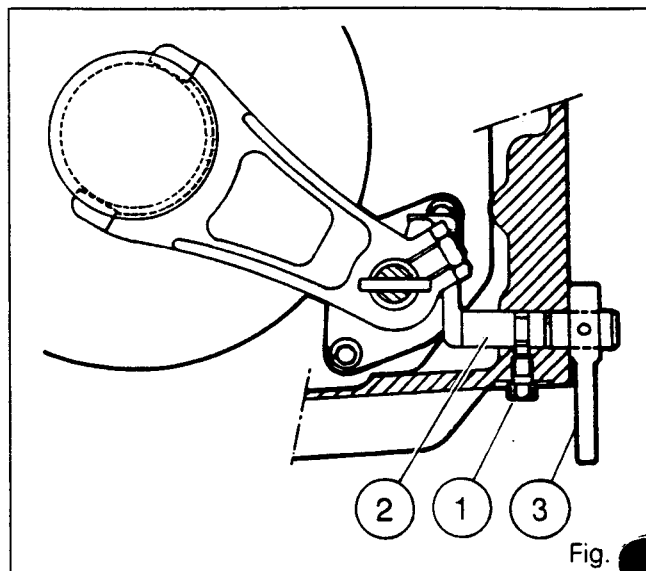

Fig.

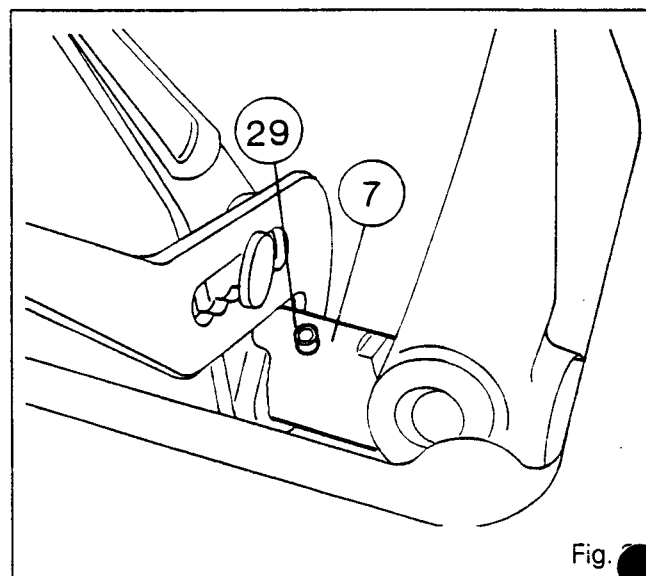

Fig.

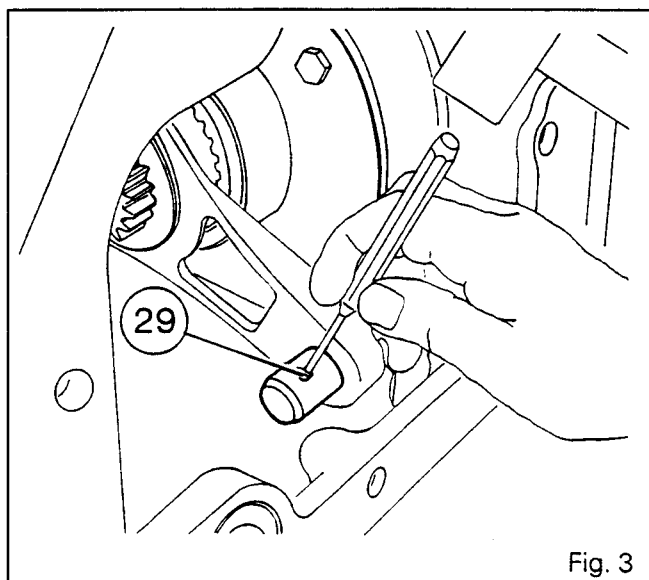

Fig. 3

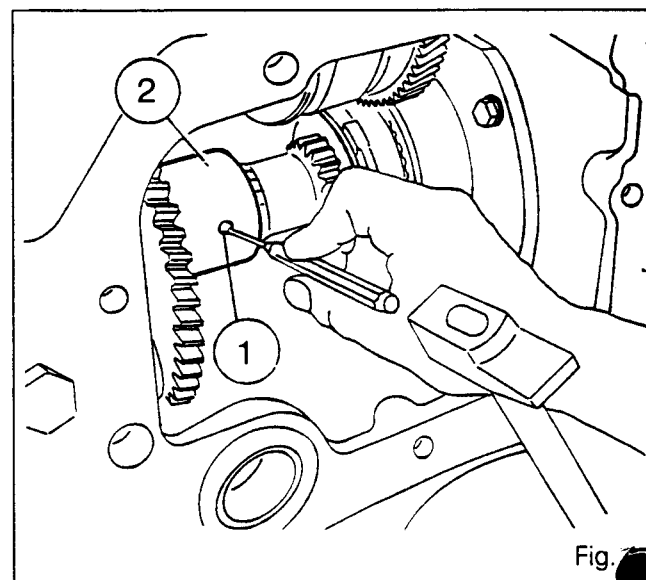

Fig.



## Gearbox - Selector rail and forks

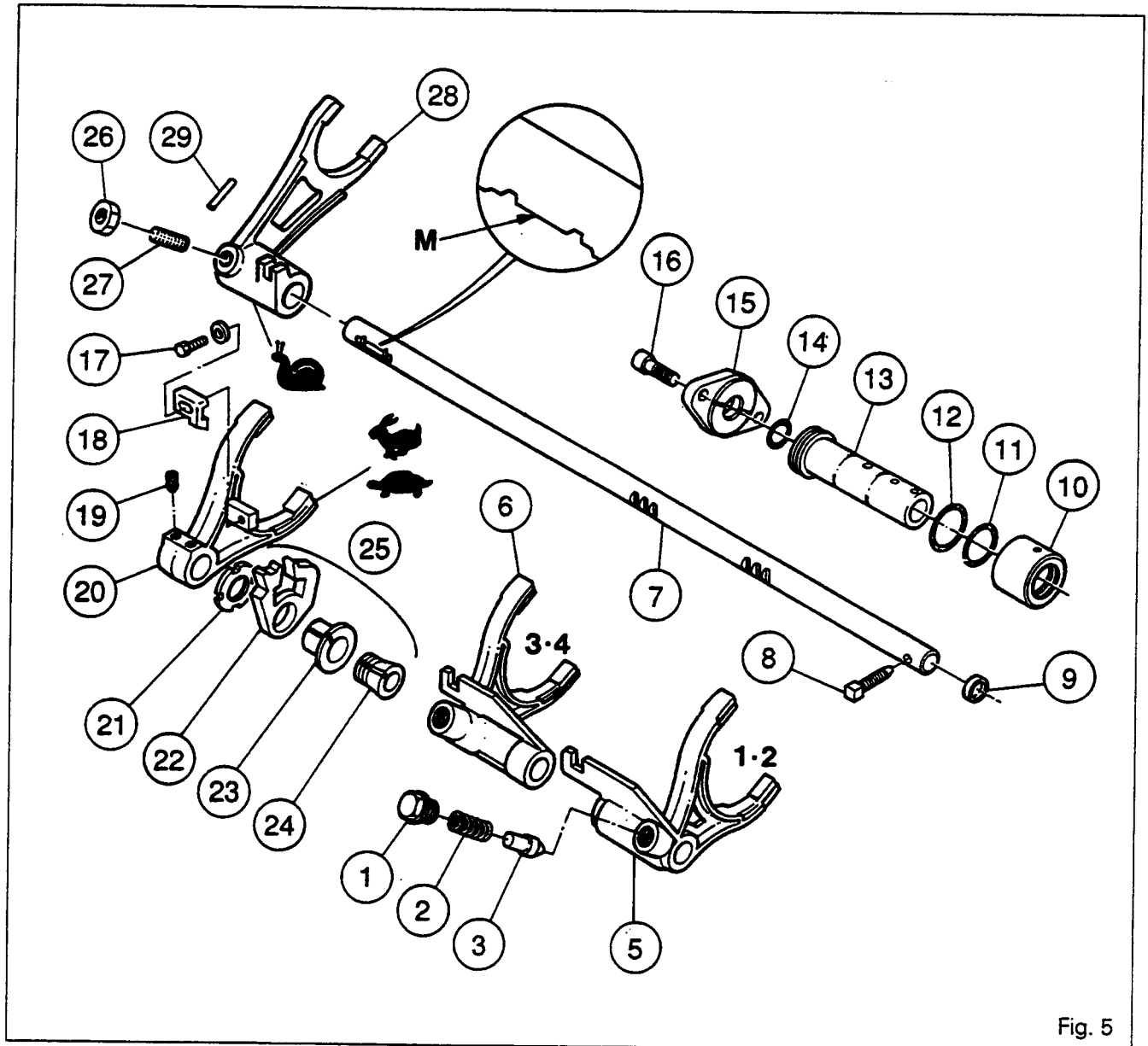

Fig. 5

### List of parts

- |                                 |                         |
|---------------------------------|-------------------------|
| (1) Plug                        | (16) Bolt               |
| (2) Spring                      | (17) Bolt               |
| (3) Locking pin                 | (18) Slider             |
| (5) 1st - 2nd gear fork         | (19) Adjusting screw    |
| (6) 3rd - 4th gear fork         | (20) Hare/Tortoise fork |
| (7) Selector rail               | (21) Castellated nut    |
| (8) Setscrew                    | (22) Latch              |
| (9) Recess plug                 | (23) Taper bearing      |
| (10) Cylinder                   | (24) Cone               |
| (11) O-ring                     | (25) Latch assembly     |
| (12) O-ring                     | (26) Nut                |
| (13) Hare/Tortoise range piston | (27) Locking screw      |
| (14) O-ring                     | (28) Creeper gear fork  |
| (15) Cover                      | (29) Dowel              |



5D01.4

# Gearbox - Selector rail and forks

### On 4WD tractors

9. Disconnect the front hose from the differential lock control (on front axle side).
10. Remove the guard (1) (Fig. 6).
11. Unscrew the centre bearing (2) from the 4WD shaft (3) (Fig. 6).
12. Remove the cotter pin (4) from the rear sleeve (5). Disengage the 4WD clutch shaft by sliding off the sleeve (Fig. 6). Turn the half-shaft so as to bring the coupling sleeve (2) into position (Fig. 4).
13. Temporarily fit the setscrew (8) in order to hold the selector rail during removal of the fork (28) (Fig. 19).
14. Slide the sleeve (2) and the coupler (1) towards each other on the connecting shaft (3) (Fig. 7).
15. Move the assembly comprising the sleeve, connecting shaft and coupler to the outer left-hand edge and then withdraw it from the fork (28) (Fig. 7).  
**Note: Mark the direction of fitting for the sleeve (2) (Fig. 7).**
16. Remove the fork (28) from the selector rail (7) (Fig. 8).
17. Remove the rod (3) (Fig. 1).
18. To remove the creeper gear control shaft (1), turn it so that it goes under the selector rail (7) (Fig. 9). Discard the O-ring (3).

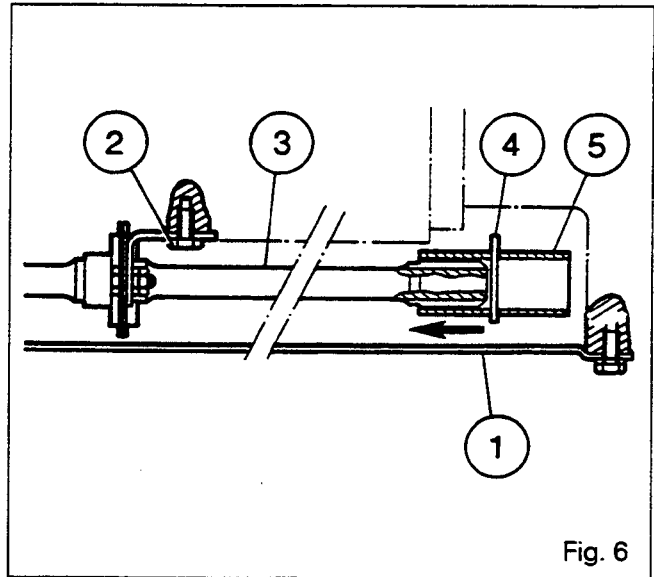

Fig. 6

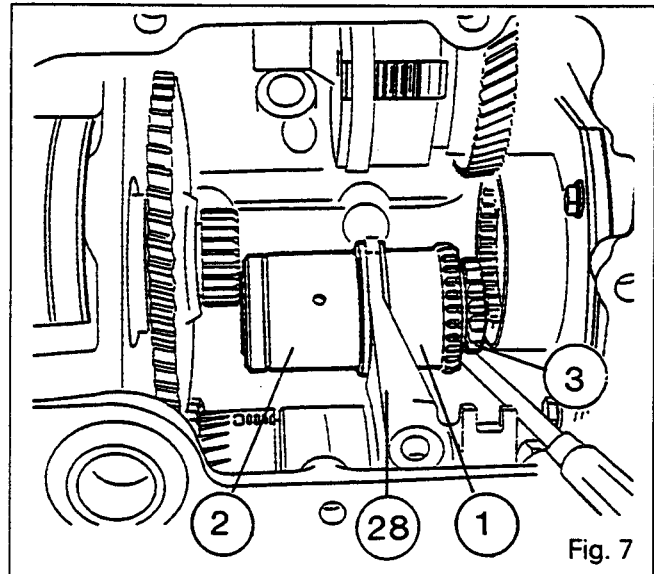

Fig. 7

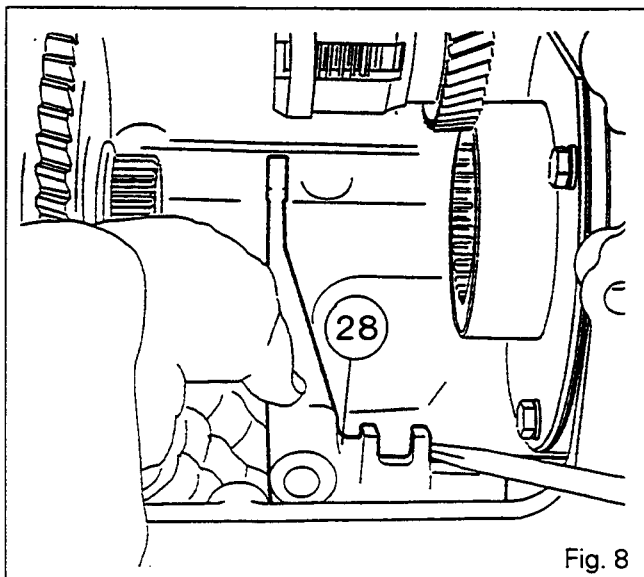

Fig. 8

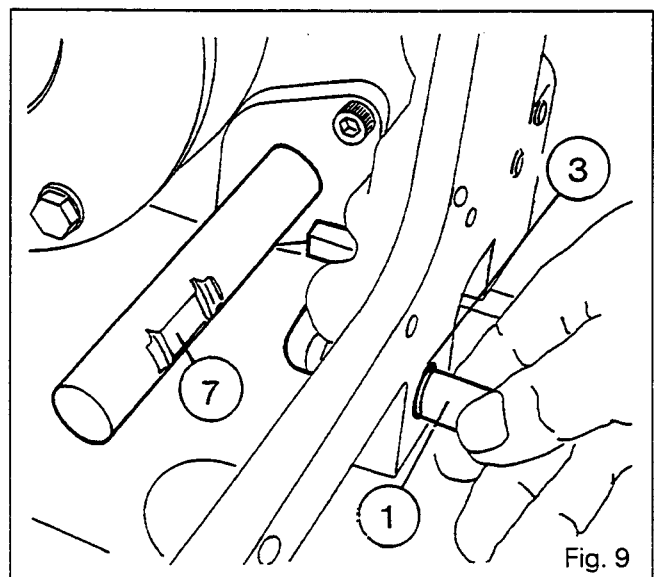

Fig. 9



## Gearbox - Selector rail and forks

5D01.5

### Reassembly

19. Check the parts and replace any that are faulty.
20. Refit the control rod. Pull the rod as far as possible to the right. Fit a new lubricated O-ring (Fig. 10).
21. Refit the rod (3) (Fig. 11).  
Coat the bolt with Loctite 241 and tighten it.
22. Fit the fork on the selector rail.  
**Note: Make sure that the finger (1) of the creeper gear control rod is pointing towards the front of the tractor (Fig. 11).**
23. Engage the sleeve, connecting shaft and coupler assembly on the left-hand outer edge and, then, fit it in the fork.  
**Note: The machined groove on the sleeve (2) must be pointing towards the rear of the tractor (Fig. 12).**
24. Slide the sleeve and the coupler onto the connecting shaft.
25. Fit a new pin (1) in the sleeve (2) (Fig. 4).
26. Remove the setscrew (8).
27. Fit a new dowel (29) and turn the selector rail (7) (Fig. 2 and 3).
28. Clean the setscrew (8), coat it with Loctite 542 and tighten it to a torque of 28 to 43 Nm.
29. Position the fork (28) and the locking screw (27) on flat M on the selector rail (7) (between the two detent notches) (Fig. 5).  
Tighten the screw to compress the ball. Loosen the screw by a quarter turn. Clean the nut (26) and coat it with Loctite 241, then tighten it to a torque of 15 to 20 Nm.  
Check that the fork locks correctly.
30. Turn and push the rod (2) to engage the finger in the fork. Fit the bolt (1) after coating it with Loctite 241 (Fig. 1).
31. Check that the rod operates correctly.
32. Prepare for the refitting of the right-hand hydraulic cover. Carry out procedures 15 to 17, in Section 9I01.
33. Check that the transfer tube O-rings are in good condition and insert the tube into the left-hand cover. (See Fig. 2 - Section 9I01).
34. Carry out procedures 20 and 18, in Section 9I01.
35. Refit the right-hand cover and the bolts. Tighten to a torque of 72 to 96 Nm.
36. Carry out procedures 7 to 11 in reverse order (Section 9I01). Fit the wiring harnesses and secure with a clip.

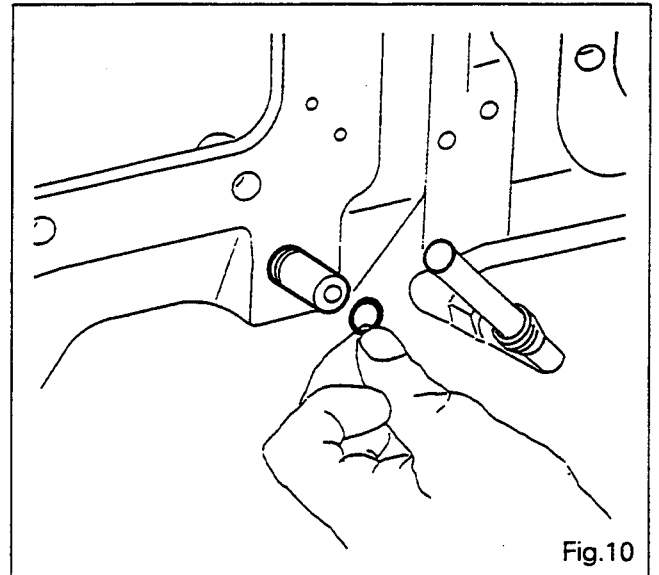

Fig. 10

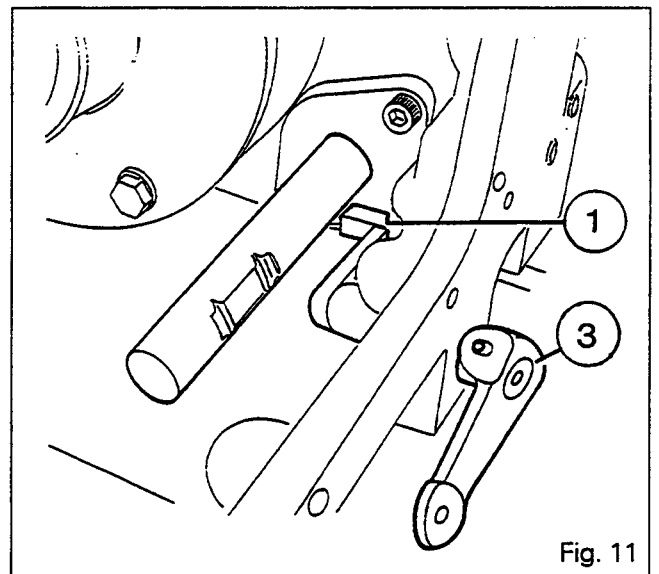

Fig. 11

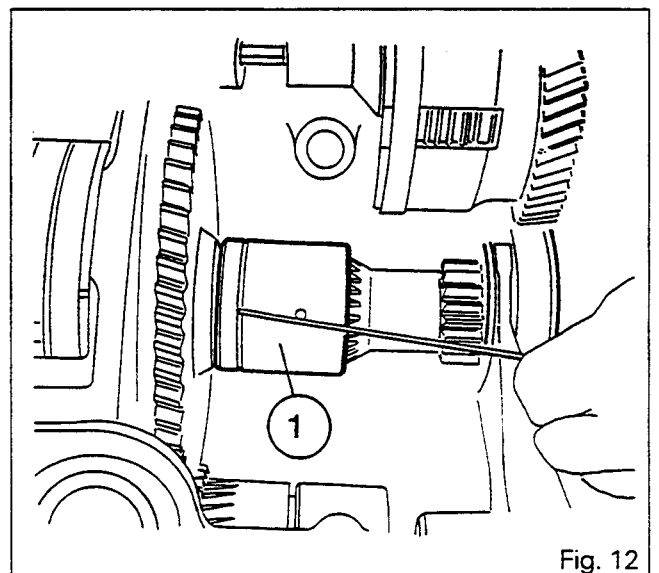

Fig. 12



5D01.6

## 6100 SERIES TRACTORS

**Gearbox - Selector rail and forks**

37. Refit the trailer brake valve (if fitted). Check that the O-rings are in good condition.  
Tighten to a torque of 25 to 35 Nm.
38. Carry out the operations in procedure 6 (Section 9I01) in reverse order.
39. Refit the trailer brake valve type (if fitted), the strainer, the filter and the filter.
40. Carry out procedures 9 to 12 in reverse order.
41. Reinstall the selector cover (see Section 5C01 or 5C02 according to version). Reconnect and adjust the creeper gear control cable (see Section 5H01).
42. Refit the wheel. Remove the stand and the jack.
43. Tighten the wheel nuts to a torque of 400 to 450 Nm.
44. Top up the oil in the gearbox and the rear axle housing.
45. Start the engine. Carry out procedure 32 in Section 9I01, and check for leaks on the cover mating face and hydraulic couplings.
46. Carry out road tests on the creeper gear control, the 1st, 2nd, 3rd and 4th gears, the Hare/Tortoise range and the electrohydraulically controlled reverse shuttle (if fitted).

## B. Hare/Tortoise fork - Mechanical lock assembly - 1st/2nd and 3rd/4th gear forks - Selector rail

### Disassembly with or without creeper gears

**Note:** For gearboxes fitted with creeper gears, the procedures marked \* must also be carried out.

47. Disconnect the creeper gear control cable.
- 48\* Disconnect the selector cover (see Section 5C01 or 5C02 according to version).
49. Remove the right-hand hydraulic cover. Carry out procedures 2 to 14, in Section 9I01.
50. Remove the plugs (1), springs (2) and locking pins (3) (Fig. 5).
- 51\* Carry out procedures 4 to 7.
- 52\* Temporarily refit the setscrew (8).
53. Loosen the castellated nut (21) using the special wrench, 3615334 M01 (Fig. 13), and see Part C.
54. Engage 4th gear.
55. Free the cone (24) on the selector rail (7) using a bronze drift (Fig. 14).
56. Remove the setscrew (8).
57. Drive out the recess plug (9) in the forward direction by tapping the end of the selector rail (7) (Fig. 15).
- 58\* Remove the creeper gear fork (28) (Fig. 19) by moving the selector rail forwards.

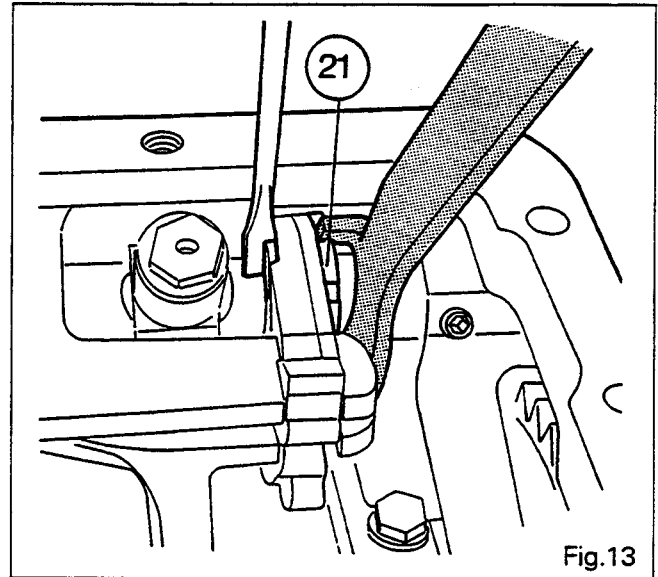

Fig. 13

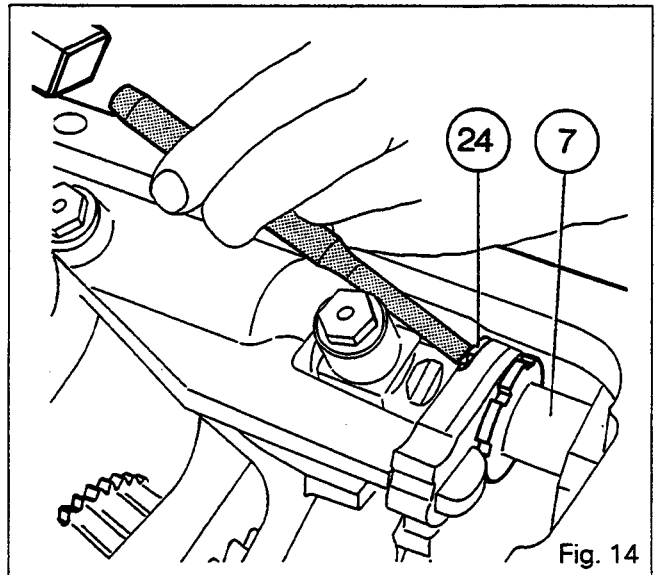

Fig. 14

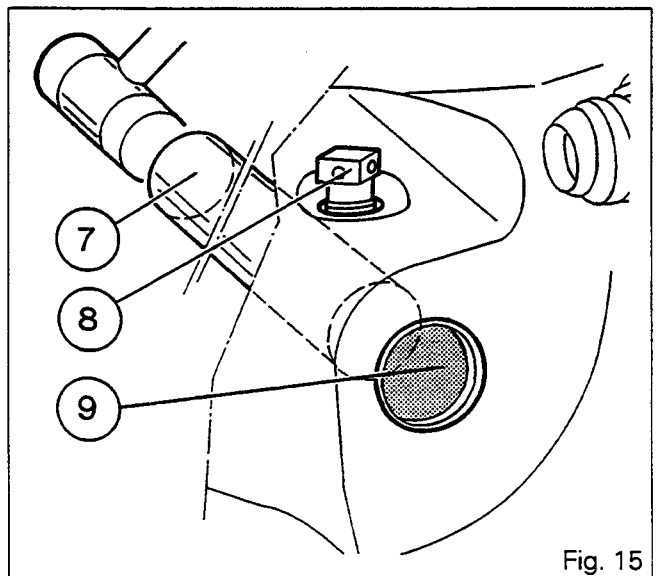

Fig. 15



## Gearbox - Selector rail and forks

59. Position the Hare/Tortoise fork (20) in the Hare position.
60. Remove the adjusting screws (19).
61. Take out the bolts (16) and remove the cover (15).
62. Remove the Hare/Tortoise piston (13) and discard the seals.
63. Remove the cylinder (10) and discard the seal.
64. Turn the pump suction pipe (1) so that it is facing upwards.  
**Note: Do not loosen the bolt (2) on the pipe clamp (Fig. 16).**
65. Move the selector rail rearwards in order to free the forks.  
**Note: Slide the selector rail under the reinforcement on the rear axle housing (Fig. 17).**
66. Withdraw the 1st, 2nd, 3rd and 4th gear forks and the latch assembly.
67. Withdraw the Hare/Tortoise fork.
68. Remove the slider (18), if necessary.
69. Withdraw the selector rail via the opening in the selector cover, feeding it through the Hare/Tortoise cylinder bore (Fig. 18).
70. Remove the latch assembly.

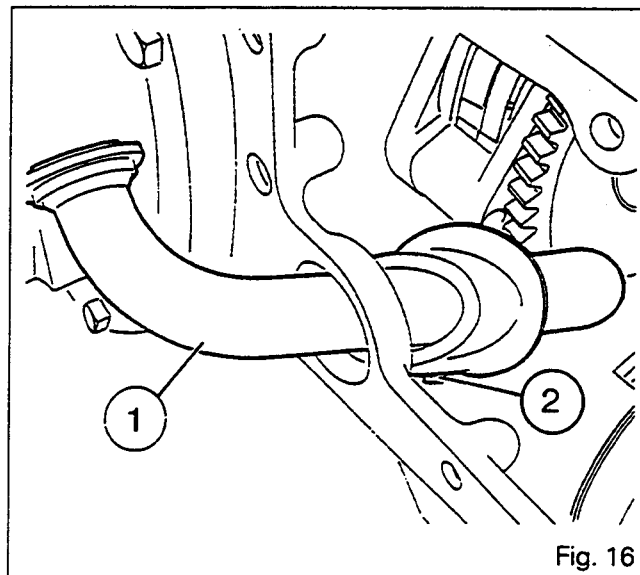

Fig. 16

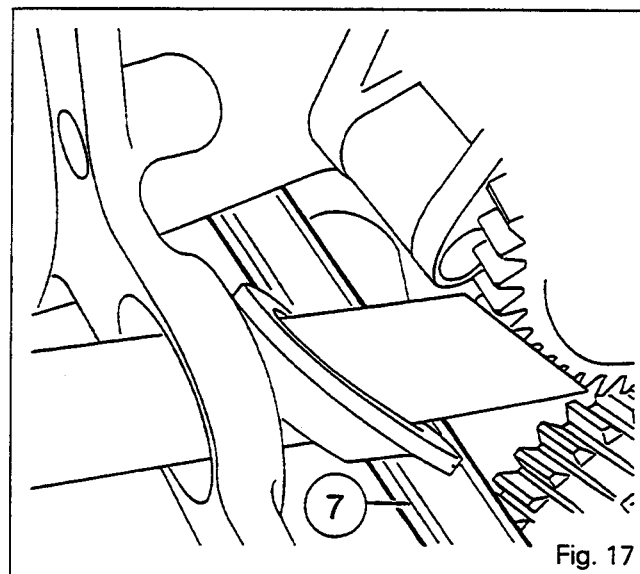

Fig. 17

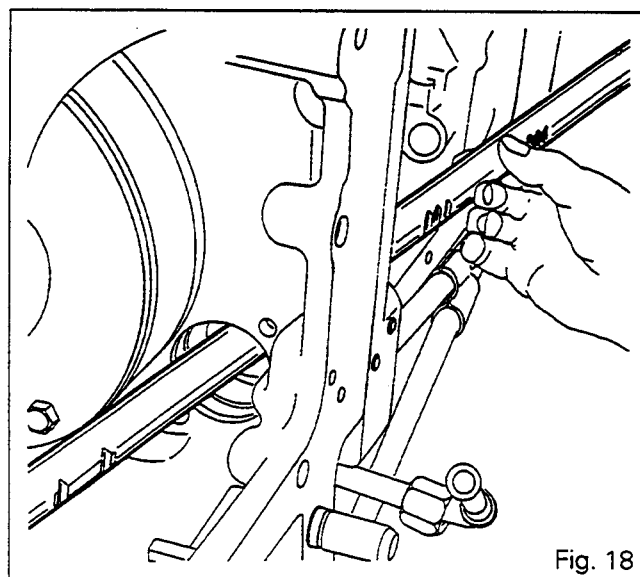
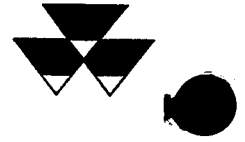

Fig. 18



5D01.8

## 6100 SERIES TRACTORS

**Gearbox - Selector rail and forks****Reassembly**

71. Check the parts and replace any that are faulty.
72. Clean the threads on the cone (24) and the tapping on nut (21).
73. Refit the latch assembly.
74. Fit the selector rail through the opening on the selector cover and the Hare/Tortoise cylinder bore (Fig. 18).
75. Refit the forks and the latch assembly.
76. Check that the hydraulic ports of the Hare/Tortoise cylinder (10) are not blocked.  
Fit the cylinder equipped with the O-ring (11).
77. Slide the selector rail forwards into the Hare/Tortoise fork, the latch assembly and the 1st, 2nd, 3rd and 4th gear forks.  
**Note: For gearboxes with creeper gears, the selector rail must be moved far enough forwards to allow fitting of the fork (28) (Fig. 19).**
78. Fit the seals (12) to (14) on the piston (13), and then insert it into the cylinder bore.  
**Note: The locations for the adjusting screws must be positioned facing the tapped holes in the fork. Immobilise the piston with a screw (19).**
79. Fit the cover (15) with the bolts (16) and tighten to a torque of 27 to 32 Nm.
- 80\* Engage the pads of the creeper gear fork in the coupler.  
**Note: The fork control finger (1) must be facing forwards (Fig. 11).**
- 81\* Slide the selector rail rearwards into the creeper gearbox.
- 82\* Fit a new dowel (Fig. 3), turning the selector rail to make installation easier (Fig. 2).
83. Clean the setscrew (8), coat it with Loctite 542 and tighten it to a torque of 38 to 43 Nm.
84. Coat the recess plug (9) with loctite 542 and fit it flush with the housing.
- 85\* Fit the locking screw (27) on the fork (28) and the nut (26) on the bolt (Fig. 5).
- 86\* Repeat procedure 29.
- 87\* Turn and push the rod (2) to engage the finger in the fork. Fit the bolt (1) after coating it with Loctite 241 (Fig. 1). Check that the rod operates correctly.
88. Fit the locking pins, the springs and the locking plugs.  
Tighten the plugs to a torque of 50 to 70 Nm.

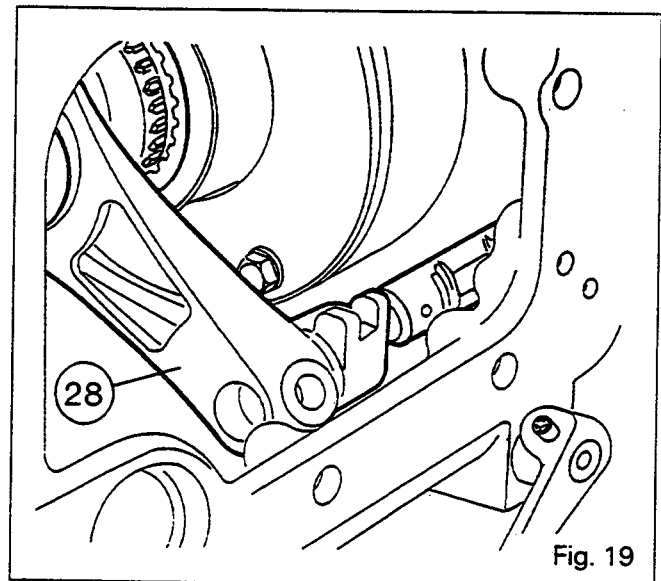



## Gearbox - Selector rail and forks

5D01.9

### 89. Adjusting the Hare/Tortoise fork

Principle: Correct positioning of the fork (20) is obtained on the basis of the difference between the distance between the tapped holes Y and the distance between the contact areas Z on the piston (13).

A difference in the displacement of the fork is obtained by acting on either the front bolt or the rear bolt, according to the adjustment required (Fig. 20).

90. Position the control piston (13) and the slide rod (31) on the high range (Hare).
91. Keep the slide rod resting against the high range gear (29) (Fig. 21).
92. Adjust the position of the fork (20) by acting on the two adjusting screws (19), after cleaning them with a solvent and applying a light coating of Loctite 221, so as to obtain a play of  $J1 = 0.3 \text{ mm}$  between the rear face of the pad and the slide rod (Figures 21 and 22).
- Note: Use the locally manufactured tool (see Part C) to make this adjustment.**
93. Position the control piston (13) and the slide rod (31) on the low range (Tortoise).
94. Check that there is a play of  $J2 = 0.3 \text{ minimum}$  (value determined by setting J1) between the pad and the slide rod when the slide rod is resting on the low range gear (36) (Fig. 23).  
Tighten the bolts to a torque of 35 Nm without modifying the adjustment.  
**Note: In the Tortoise position, if face X of the pad of the fork (20) is resting on the slide rod (Fig. 23), increase play J1.**
95. Place the fork in the Tortoise position.
96. Slightly loosen the castellated nut (21). Apply a moderate coating of Loctite 270 on the threads of the cone (24).

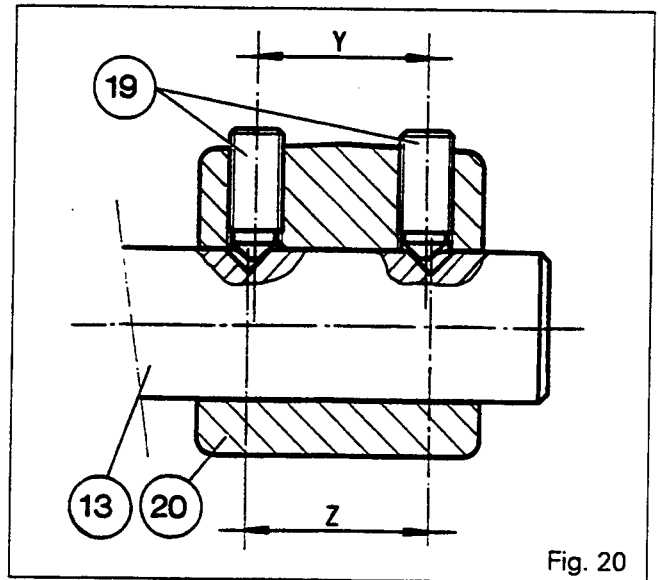

Fig. 20

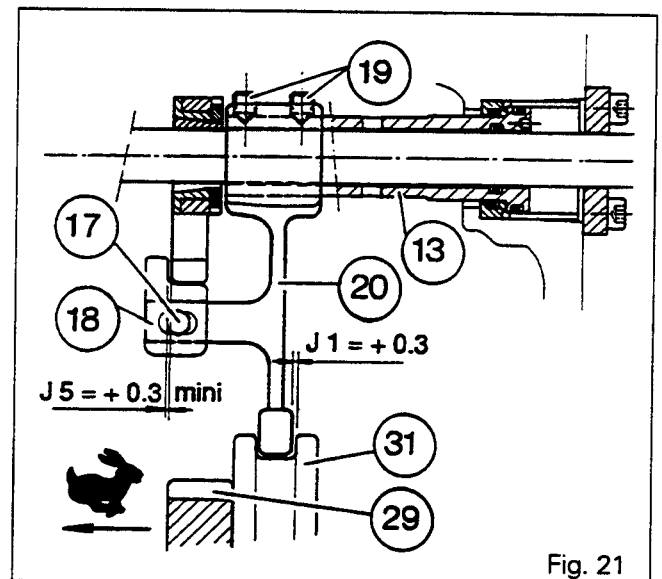

Fig. 21

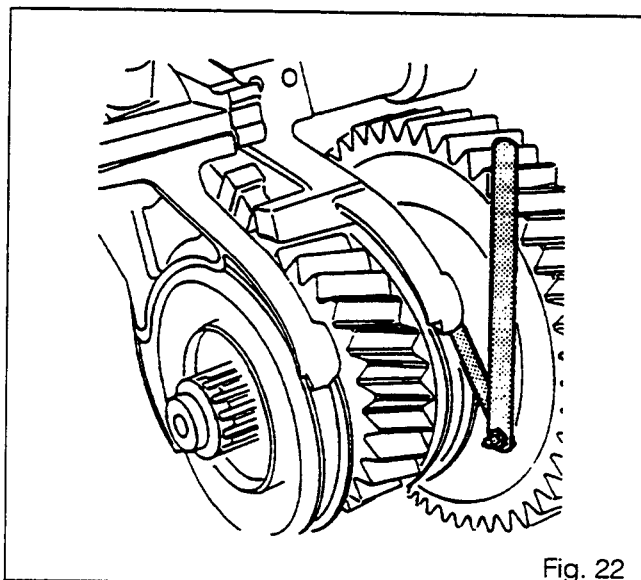

Fig. 22

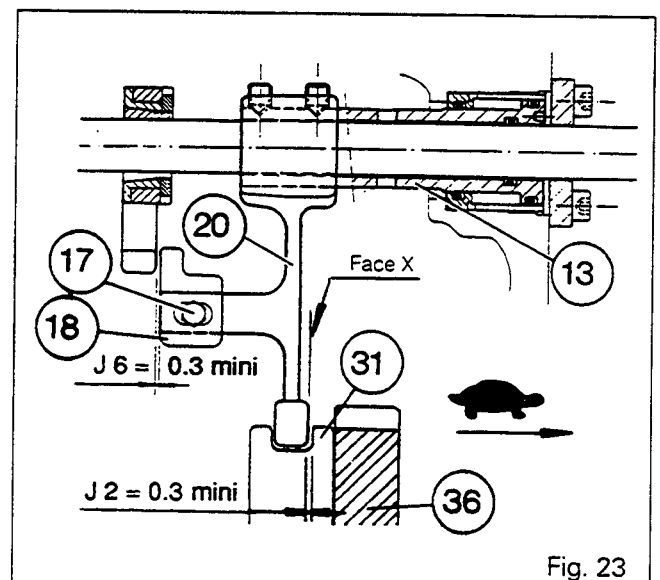

Fig. 23





5D01.10

# Gearbox - Selector rail and forks

- 97. Place the forks in the neutral position.
- 98. Apply plays **J3** and **J4 (min. = 0.3 mm)** equally so that the mechanical latch (**22**) operates unhampered (Figures 24 and 25).
- 99. Tighten the castellated nut (**21**) to a torque of 50 Nm using the special wrench, 3615334 M01, and a spring scale (Fig. 26).
- 100. Coat the locking face of the slider (**18**) with Loctite 648 and coat the bolt (**17**) with Loctite 241. Fit the washer and the bolt.
- 101. Balance the plays, **J5** and **J6 (min. = 0.3 mm)**, between the slider and the latch in the Hare and Tortoise positions (Figures 21, 23, 27 and 28).
- 102. Tighten the bolts to a torque of 36 to 46 Nm.
- 103. Check that the Hare/Tortoise range and the latch operate correctly.
- 104. Check the operation of the gearshift.

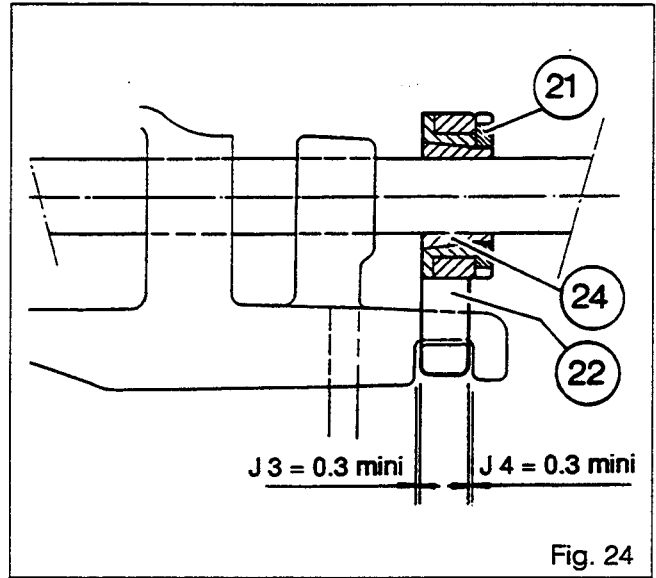

Fig. 24

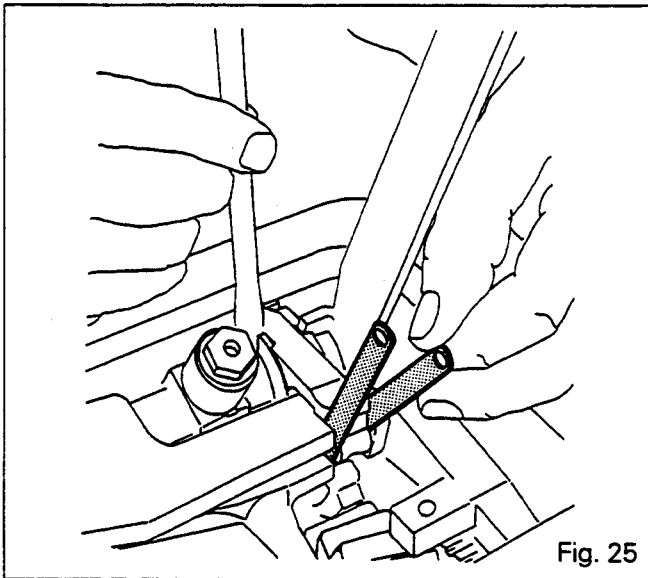

Fig. 25

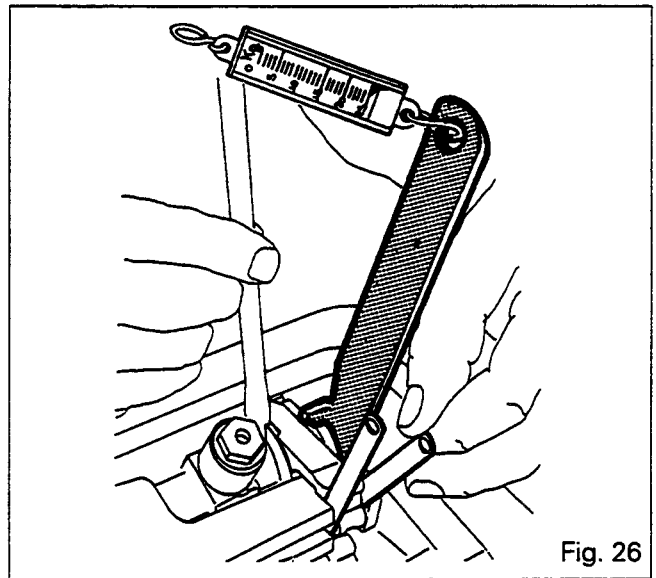

Fig. 26

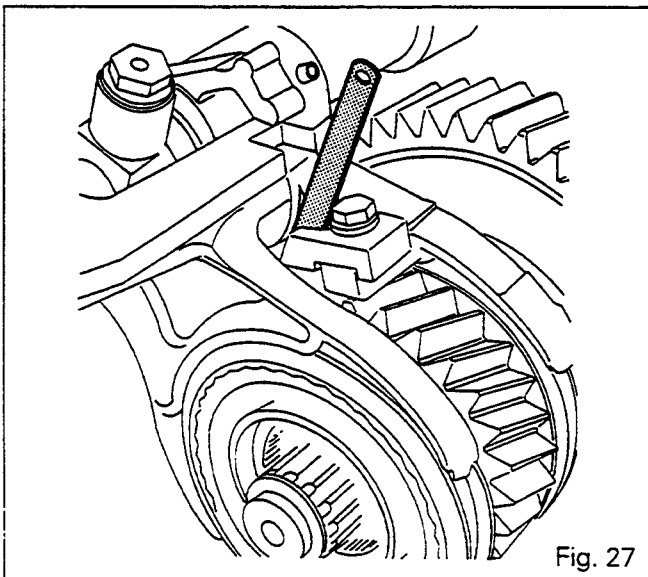

Fig. 27

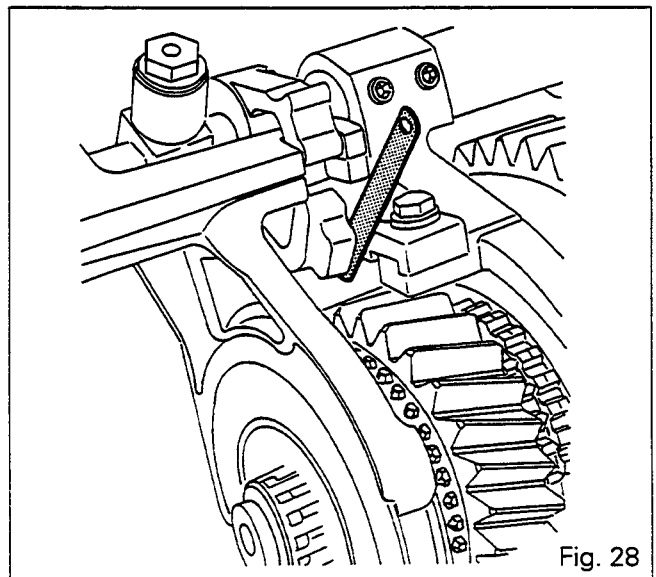

Fig. 28



## Gearbox - Selector rail and forks

105. Fit the right-hand cover. Carry out procedures 15 to 27, in Section 9I01.
106. Fit the selector cover, see Section 5C01 or 5C02 according to version.
- 107\* Reconnect the creeper gear control cable and adjust it (see Section 5H01).
108. Fit the wheel. Remove the stand and the jack. Reinstall the footstep (if removed).
109. Tighten the wheel nuts to a torque of 400 to 450 Nm.
110. Top up the oil in the gearbox, remove the wedges and release the handbrake.

### Road test on controls

- . creeper gears (if fitted),
  - . Hare/Tortoise range,
  - . 1st, 2nd, 3rd and 4th gears,
  - . electrohydraulically controlled reverse shuttle (if fitted).
111. Check for leaks on the mating faces of the covers and on hydraulic unions.

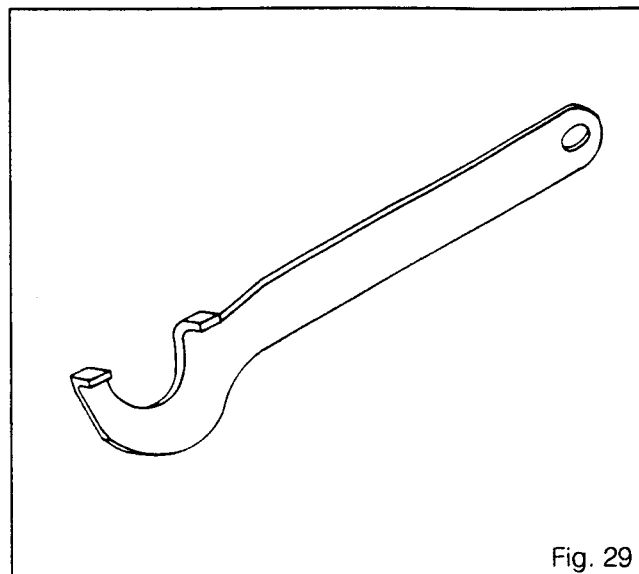

Fig. 29

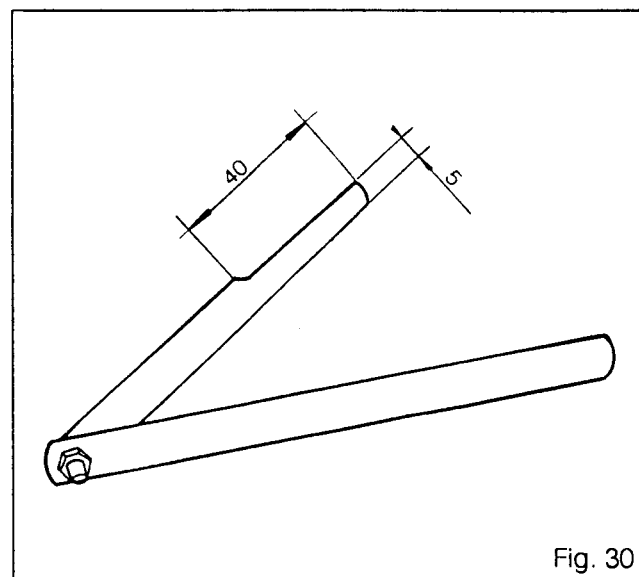

Fig. 30

## C. Service tools

Tool available through the MF network  
3615334M1 - Pin wrench (Fig. 29)

Tool to be manufactured locally  
Set of shims (Fig. 30) using saw blade



5D01.12

## 6100 SERIES TRACTORS

**Gearbox - Selector rail and forks****D . Selector rail (Heavy Duty gearbox)**

The gear selection principle used is identical to that used on the standard gearbox.

The positions of the 1st - 2nd and 3rd - 4th synchromeshes have been modified according to the design of the heavy duty gearbox.

The location of the detent notches on the selector rail (7) has also been modified.

The cylinder (10) and the Hare/Tortoise control piston (13) are different from those used on the standard gearbox.

The cylinder (10), which is shouldered on its outside diameter in contact with the shoulder on the centre housing, is held by the cover (15).

On the piston (13), the location of the indentations provided for adjustment of the Hare/Tortoise fork has been modified in accordance with the position of the synchromesh on the output shaft.

On the forks (1st-2nd, 3rd-4th and Hare/Tortoise), the distance between the pads has been increased to allow for the different diameter of the double cone synchromesh slide rods.

The support for the slider screwed onto the Hare/Tortoise range fork is longer.

Work is carried out on the selector rail, the fork, the cylinder and the Hare/Tortoise piston according to the same procedure as on the standard gearbox.

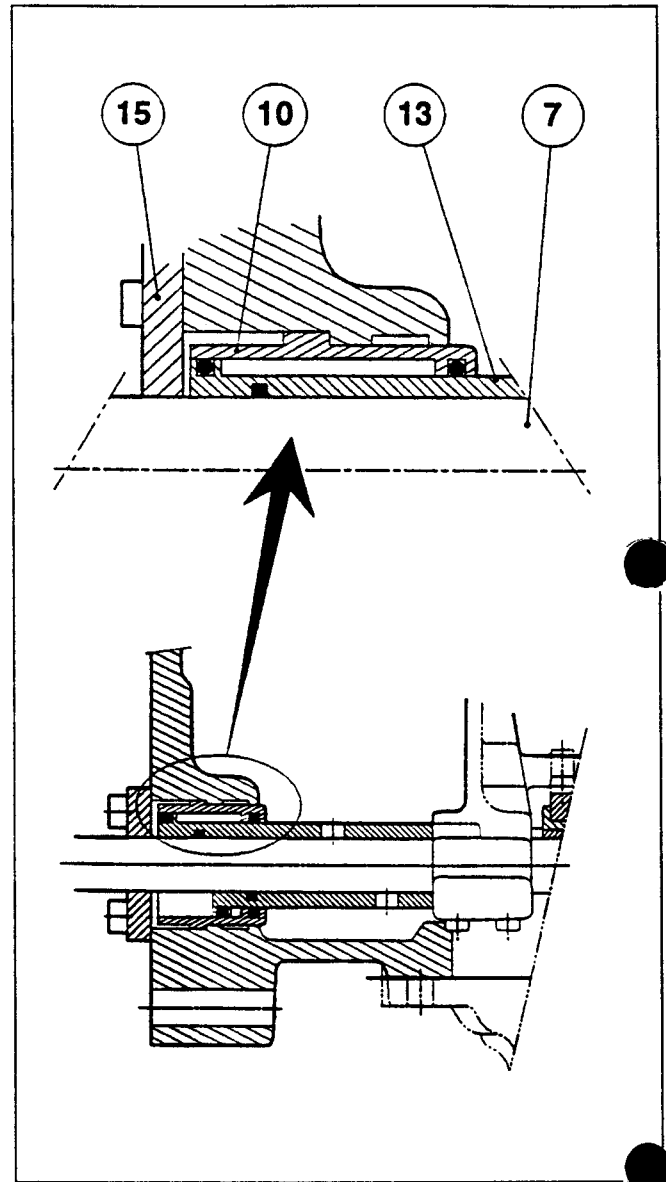



## **Gearbox - Output shaft**

### 5 E01 Output shaft

#### CONTENTS

-	<b>General</b> _____	2
A.	<b>Preliminary operations</b> _____	4
B.	<b>Removing the selector cover</b> _____	4
C.	<b>Disassembling the guide rails and selector forks</b> _____	4
D.	<b>Disassembling the output shaft</b> _____	5
E.	<b>Reassembling and shimming the output shaft</b> _____	6
F.	<b>Reassembling the guide rail and selector forks</b> _____	9
G.	<b>Refitting the selector cover</b> _____	11
H.	<b>Final operations</b> _____	11
I.	<b>Service tools</b> _____	12



5E01.2

## 6100 SERIES TRACTORS

**Gearbox - Output shaft****General**

The output shaft transmits the drive provided by the various gear ratios to the rear axle transfer shaft. It is mounted on the lower transmission drive line at the rear of the gearbox.

At the front end, it is supported by a needle-roller bearing located in the bore in the mainshaft and, at the rear end, in two taper bearings fitted with their tapers in opposition.

The shaft (44) carries:

- the driving gear (29) which is mounted to rotate freely on combination bearings (28) and (30),
- the gear (36) and bush (35) assembly which are mounted to rotate freely,
- the Hare/Tortoise (Hi/Lo) coupler (31) and its hub which are splined to rotate together.

To ensure that the assembly will operate correctly under the forces applied to the transmission, several settings have to be made with shims:

- **Setting J3:** with shim or shims [47], this setting allows the clearance to be taken up between the cones (39) and (40) and their respective cups.
- **Setting J4:** shim or shims [38] placed between the shoulder on the shaft (44) and the cone (39) allow(s) end play on the gear (29).
- **Setting J5:** shim or shims [42] placed between the cone (40) and packing shim [43] take up the end play of cones (39) and (40) on the shaft (44).

Overall view

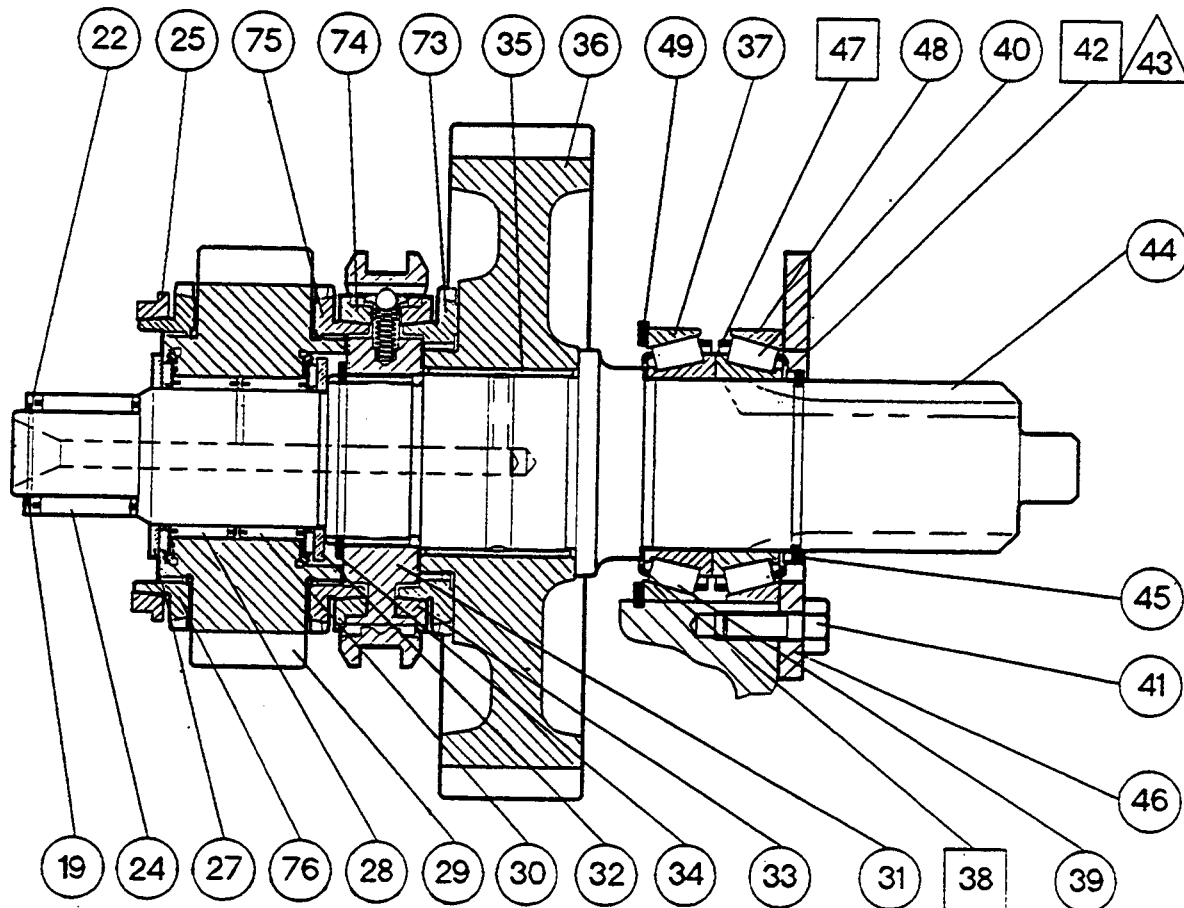

Fig. 1



**Gearbox - Output shaft**

5E01.3

Exploded view

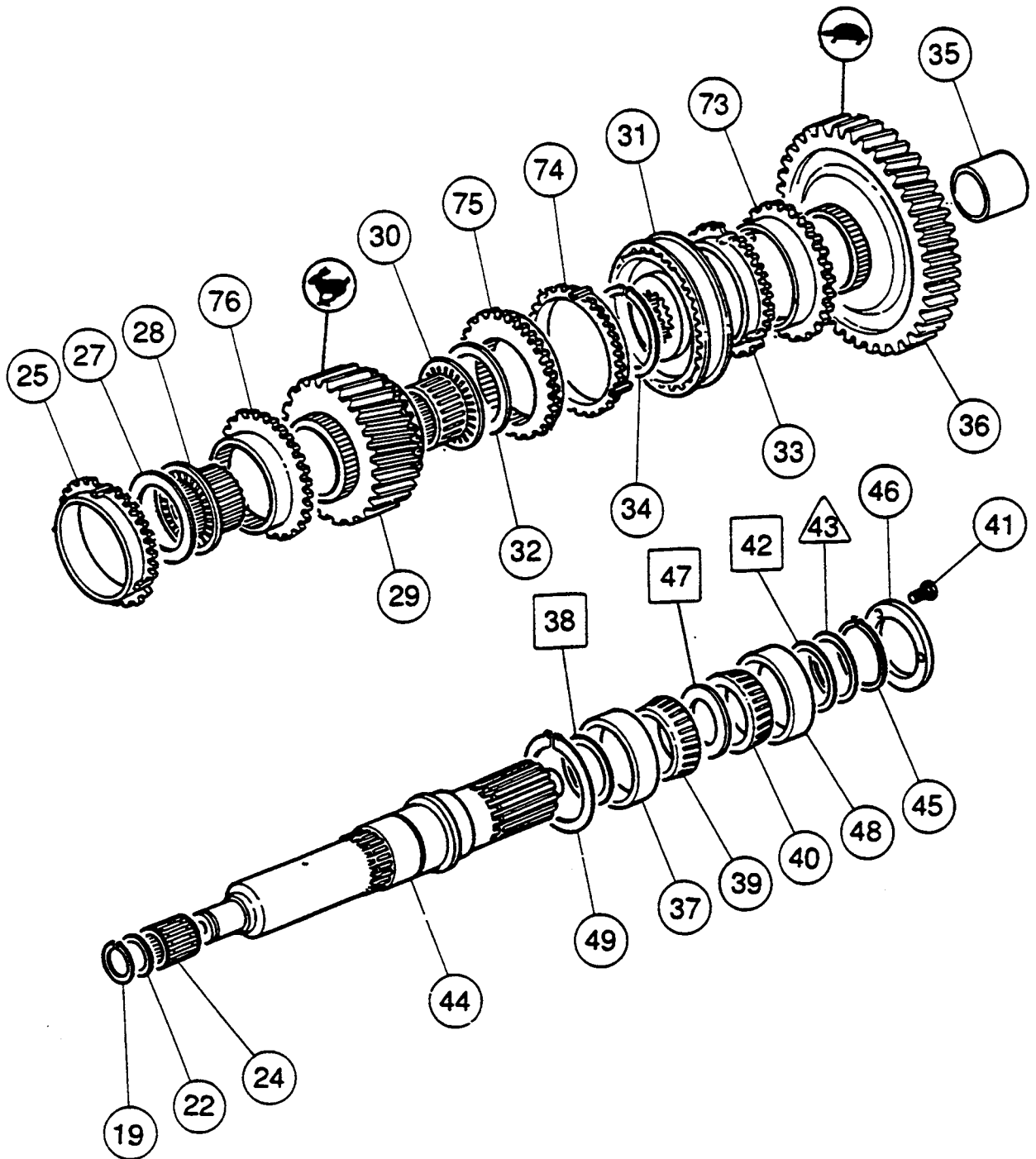

Fig. 2



# 6100 SERIES TRACTORS



5E01.4

## Gearbox - Output shaft

### A . Preliminary operations

1. Split the tractor between the gearbox and the rear axle (Section 2 B01).

### B . Removing the selector cover

2. See section 5 C01 or 5 C02 in according to version.
3. If necessary, remove the bolt (1) (see Fig. 13).

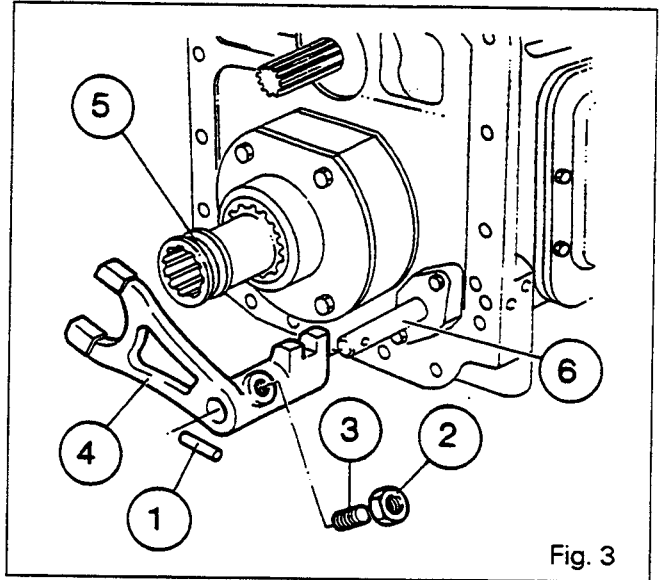

Fig. 3

### C . Removing the guide rail and forks

**Note: Gearbox equipped with creeper gears.**  
 Remove pin (1) locknut (2), adjustable locking screw (3), and fork (4) with sleeve (5) (see Fig. 3).

4. Remove the plugs (1), springs (2) and locking plungers (3) (See Fig. 5).
5. Slacken off the castellated nut (21) using spanner 3615334 M1 (see Fig. 4).
6. Engage 4th gear.

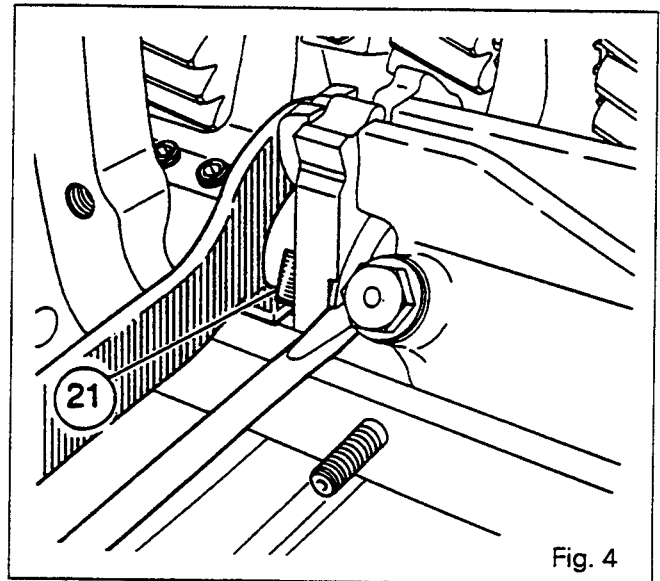

Fig. 4

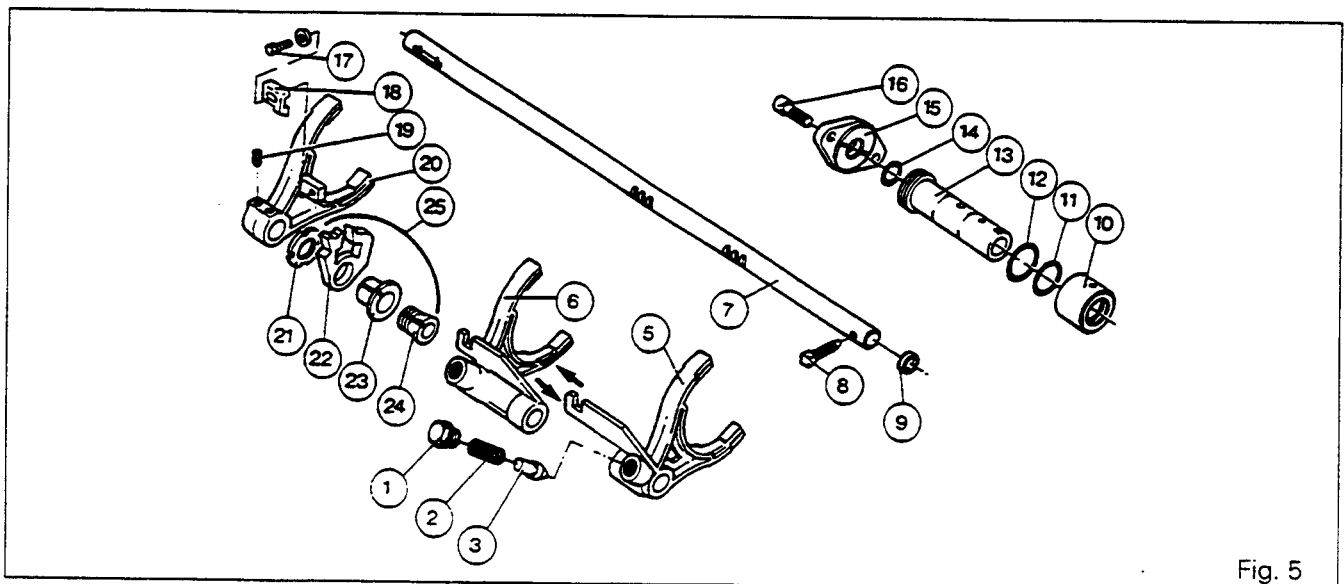

Fig. 5



## Gearbox - Output shaft

7. Free the cone (24) on the guide rail (7) using a bronze drift (see Fig. 6).
8. Remove the set screw (8).
9. Remove the bearing (15), the guide rail (7) from the rear, the forks (5) and (6) and the locking assembly (25).
10. Dismantle the castellating nut (21), locking device (22), bearing (23) and cone (24).  
Remove the bolts (19), piston (13), the Hare/Tortoise (Hi-Lo) fork (20), the bolt and washer assembly (17) slider (18) and cylinder (10).  
**Note: Discard the seals (11), (12) and (14).**

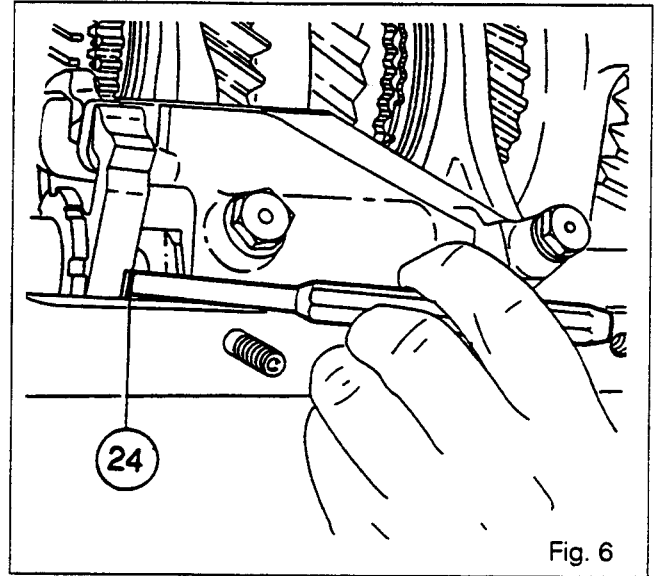

Fig. 6

### D . Removing the output shaft

**Note: Remove the creeper gearbox if the tractor is fitted with one.**

11. Move the three screws (41).
12. Remove the locking ring (46).
13. Remove the bearing cup (48).  
**Note : Keep the cones and cups in pairs if they are to be re-used.**
14. Remove the circlip (45).
15. Remove the packing shim /43\ and the adjusting shims [42].
16. Remove the bearing cone (40).  
**Note : If shimming was required between the cones, remove the shim or shims [47].**
17. Remove the cone (39).
18. Remove the adjusting shims (38).
19. Pull the shaft (44) towards the rear.
20. Remove the snap ring (34) using tool MF 460 and discard it (see Fig. 7).
21. Remove the shaft.
22. Through the opening in the selector cover, take out the synchromesh (31), the synchromesh rings (33) and (74), the gear (29) with cones (75) and (76), the ring (25), the two thrust washers (27) and (32) and the Tortoise gear (36).  
**Note: Keep the synchromesh rings (25) and (74) paired with the cones (75) and (76), and ring (33) with cone (73).**
23. Remove the cap (37) and circlip (49).
24. Remove circlip (19), washer (22) and the needle-roller bearing (24).

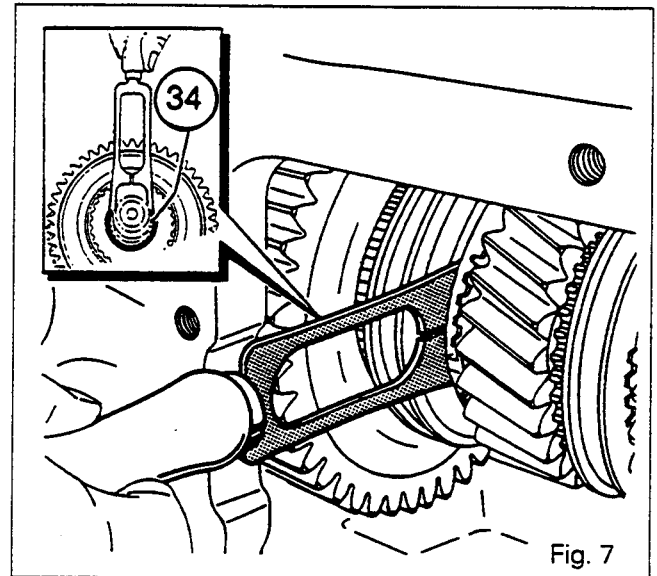

Fig. 7





5E01.6

# 6100 SERIES TRACTORS



## Gearbox - Output shaft

### E. Reassembling and shimming the output shaft

- 25. Check and clean the parts, and replace any that are faulty.
- 26. Fit the circlip (49) and cup (37).
- 27. Reinstall the needle-roller bearing (24), washer (22) and circlip (19) on the shaft (44). Engage the shaft in the housing without gears.
- 28. Slide the cones (39) and (40) onto the shaft.

#### Setting J3

29. The purpose of this operation is to prepare for setting **J3** (Fig. 8). Hold the cones (39) and (40) fully home against the shoulder of shaft (44) by pressing on them by hand.

Fill the gap **Y** between the rear of the cone (40) and the groove for circlip (45) with shims [42] and the packing shim /43/. Choose a new circlip that provides a slightly tight fit in the groove (Fig. 10).

30. Perform the setting (Fig. 9) with shims in order to obtain :

**J3 = Preload of 0,05 to end play of 0,05**

This shimming operation consists in taking up the clearance between the cones (39) and (40) and the cups (37) and (48), while complying with the setting tolerance specified above.

31. Fit the circlip (45).

**Note : Position the packing shim on the circlip side.**

32. Fit the cup (48) and the locking ring (46).

33. Tighten the bolts (41) to a torque of 27 - 32 Nm.

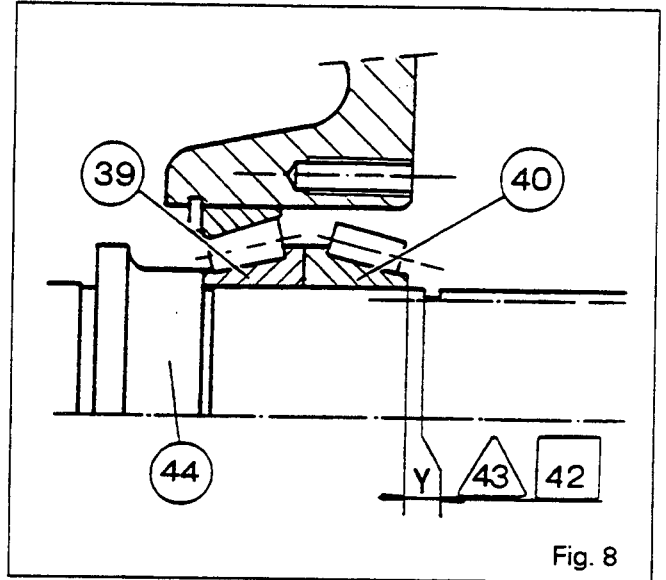

Fig. 8

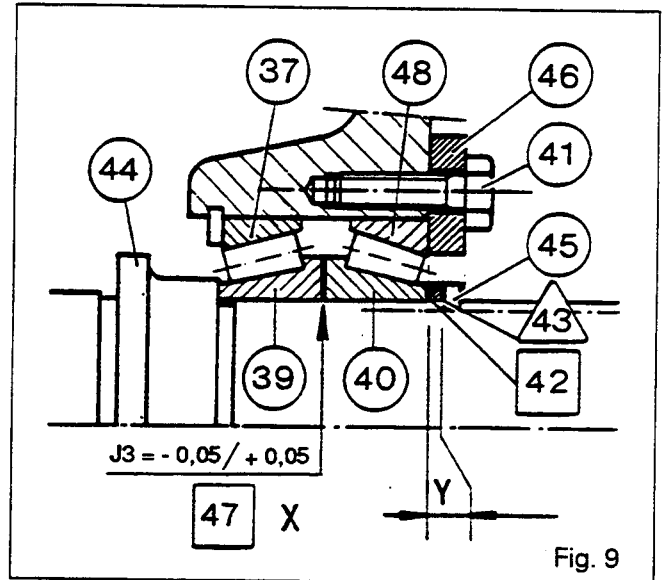

Fig. 9

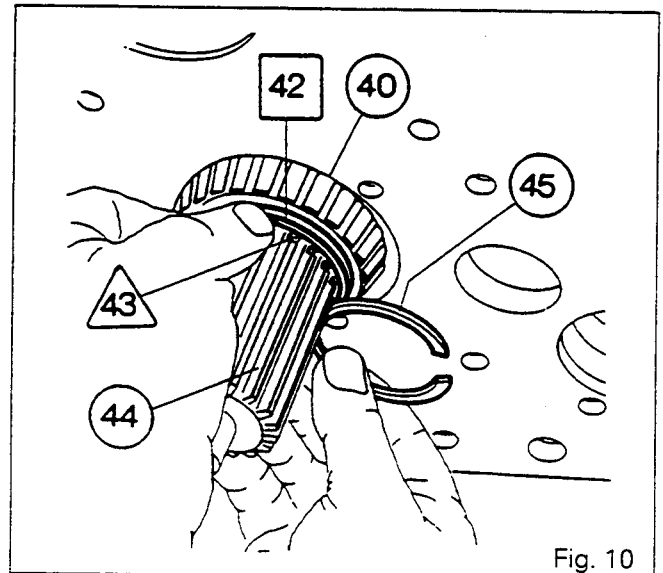

Fig. 10



## Gearbox - Output shaft

34. Position a dial gauge on the end of the shaft (44) (Fig. 11).

**Note: In the case of gearboxes equipped with creeper gears, use the gearbox locking ring (see Fig. 12) in place of the locking ring. Tighten the bolt to a torque of 34 - 52 Nm.**

35. Push on the shaft while turning it alternately clockwise and then anticlockwise to seat the cones correctly in the cups.  
 36. Reset the dial gauge to zero.  
 37. Repeat procedure 35 while pulling on the shaft.  
 38. If the end play measured is greater than 0.05 mm select a thickness of shims X [47] to obtain : **J3.**  
**Important: The shim or shims X [47] selected for J3 must be installed between the cones for the following setting operations.**

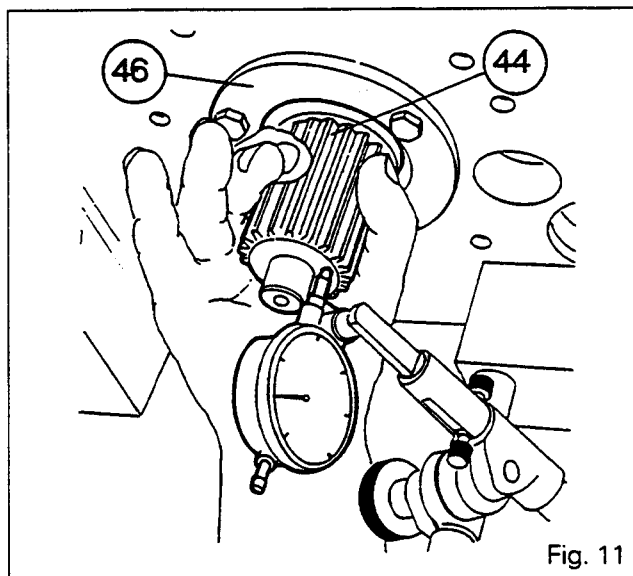

Fig. 11

### Setting J4

39. Remove the circlip (45).  
 40. Remove the packing shim /43\ and the adjusting shims [42].  
 41. Measure the thickness Y of the set of shims [42] and /43\. (This measurement will be useful for setting J5.)  
 42. Remove the bolts (41) and the locking ring (46).  
 43. Remove the cup (48), cones (40) and (39), and the shaft (44).  
 44. Fit the following in the housing: the Tortoise gear (36), the synchromesh and its rings (33) and (74), the thrust washer (32), the gear (29) with its needle-roller bearings (30) and (28) and its synchromesh cones (75) and (76), thrust washer (27) and synchromesh ring (25).  
**Note: If bush (35) shows signs of wear, replace the complete gear assembly. (The bush is reamed after fitting). If the combination bearings (30) and (28) are worn, replace the complete gear assembly. (Bearings are fitted in the factory).**  
 45. Insert the output shaft (44) while holding the gear assembly in position (see Fig. 13).  
 46. Pull the shaft slightly back in order to expose the groove for the snap ring (34).

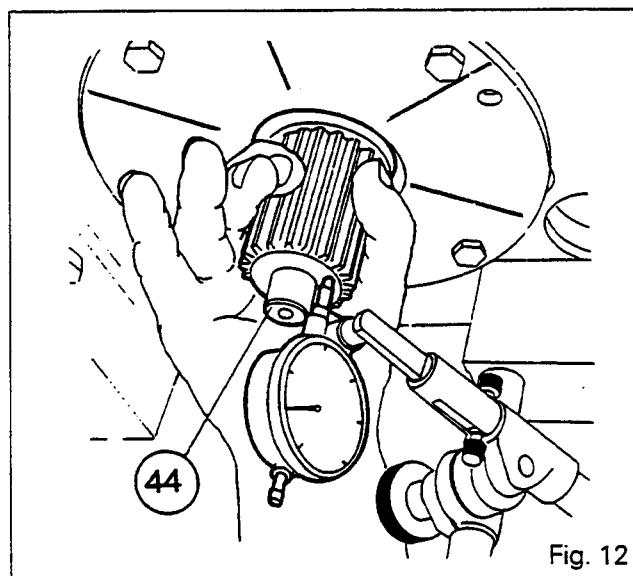

Fig. 12

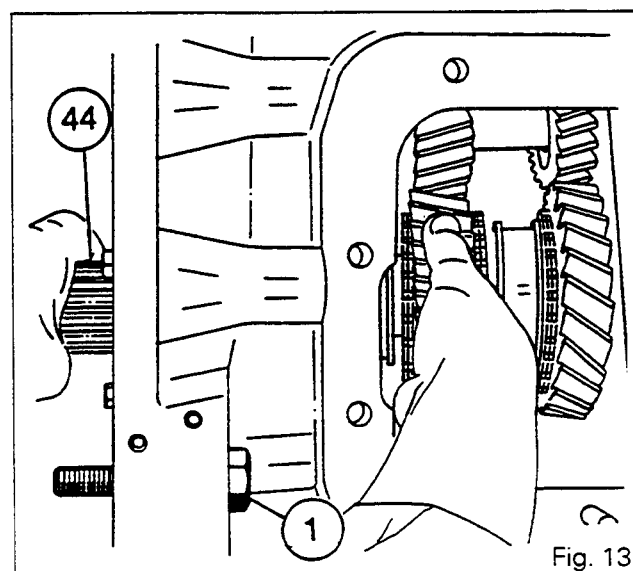

Fig. 13



5E01.8

## 6100 SERIES TRACTORS

**Gearbox - Output shaft**

47. Fit the snap ring (34) with tool MF 459 (Fig. 14).  
**Note: Check that the snap ring is correctly installed.**

48. Slide the following components onto the shaft: cone (39), shim or shims X [47] selected in procedure 38, cone (40) and cup (48).  
 49. Fit the locking ring (46). Tighten the bolts (41) to a torque of 27 - 32 Nm.  
 50. Perform the setting (Fig. 15) to obtain a play of :  
**J4 = 0.20 to 0.40**  
 This setting operation consists in providing an end play on the gear (29).  
 51. Carry out procedures 34 to 37.  
 52. According to the measurement read on the dial gauge, determine the thickness of shims Z [38] to obtain play J4.  
 53. Remove the bolts (41) and the locking ring (46).  
 54. Remove the cup (48).  
 55. Withdraw the cones (40) and (39), and the shim or shims X [47].  
 56. Slide the following components onto the shaft: the required thickness of shims Z [38], cone (39), shim or shims X [47], and cone (40).

**Setting J5**

57. Perform the setting (Fig. 16) to obtain :  
**J5 = no end play**  
 This setting consists in taking up the end play of cones (40) and (39) on the shaft (44).  
 58. Use the thickness of shims Y [42] /43\, measured in procedure 41, to deduce the thickness of shims Z [38] and X [47] to obtain :  $J5 = Y - (Z + X)$ .  
 59. Carry out procedures 32 and 33.  
 60. Slide the thickness of shims selected in procedure 58 onto the shaft.  
 61. Fit the circlip (45).  
**Note: Position the packing shim /43\ on the circlip side.**  
 The circlip must be a slightly tight fit in its groove. Check that it is correctly positioned.  
**Note: Refit the creeper gearbox (if fitted).**  
 62. Check by hand that the shaft and its gears turn freely.  
 63. Check that the 3rd and 4th gear and Hare/Tortoise synchromeshes operated normally.

Fig. 14

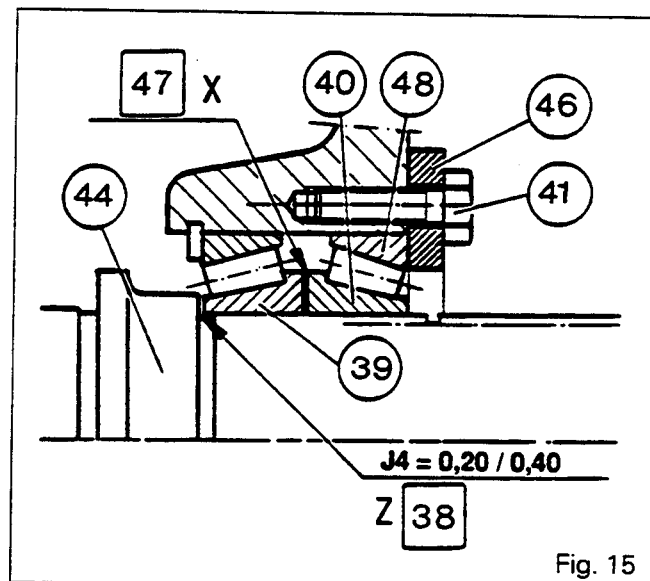
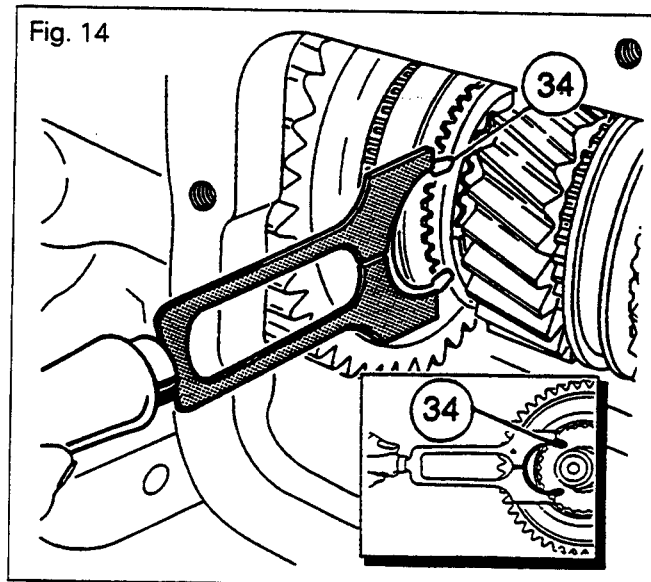

Fig. 15

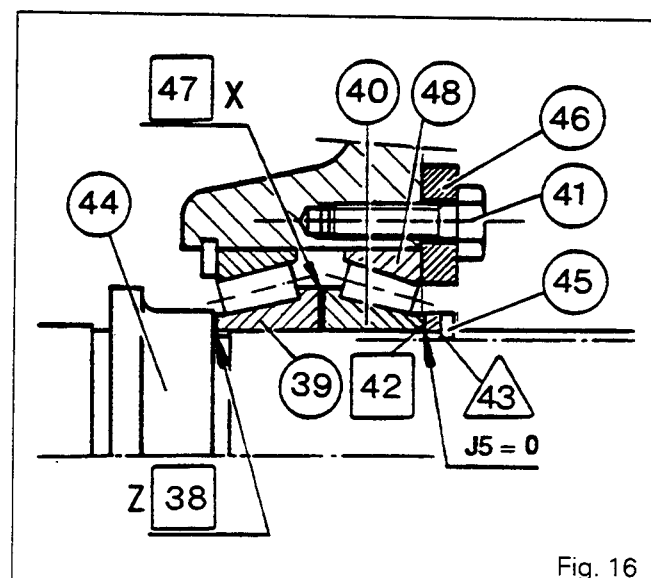

Fig. 16



## Gearbox - Output shaft

### F. Reassembling the guide rail and forks (Fig. 17)

64. Check that the ports in the Hare/Tortoise cylinder (10) are not blocked.
65. Fit the cylinder (10) equipped with O-ring (11) in the housing.
66. Install the Hare/Tortoise fork (20) in the synchro-mesh.
67. Fit seals (12) and (14) onto the piston (13) and then insert it into the bore in the cylinder.  
**Note : Line up the locations for the adjusting screws with the tapped holes in the fork. Immobilise the piston with a screw (19).**
68. Clean and then assemble the mechanical locking device (22), taper bearing (23), cone (24) and castellated nut (21).
69. Fit the 3rd and 4th speed fork (6) and the 1st and 2nd speed fork (5), and the locking assembly (25).
70. Insert the guide rail (7) from the rear of the housing and slide it through the piston, the locking assembly and the forks.
71. Fit the bearing (15) and tighten the bolts (16) to a torque of 27 - 32 Nm.
72. Clean the set screw (8) with a solvent. Coat it with Loctite 542 and tighten to a torque of 28 - 43 Nm.
73. Fit the locking plungers (3) and springs (2), and tighten the plugs (1) to a torque of 50 - 70 Nm.  
**Note : Gearboxes equipped with creeper gears (Fig. 3).**
  - Fit sleeve (5), fork (4) and pin (1).
  - Position the fork so that locking screw (3) is over the flat on the guide rail (6) (between the two locking recesses).
  - Tighten the screw fully in so that the ball is compressed.
  - Loosen the screw by one quarter turn.
  - Apply Loctite 241 to nut (2) after cleaning it with solvent.
  - Tighten to a torque of 15 - 20 Nm.
  - Check that the fork locks correctly.

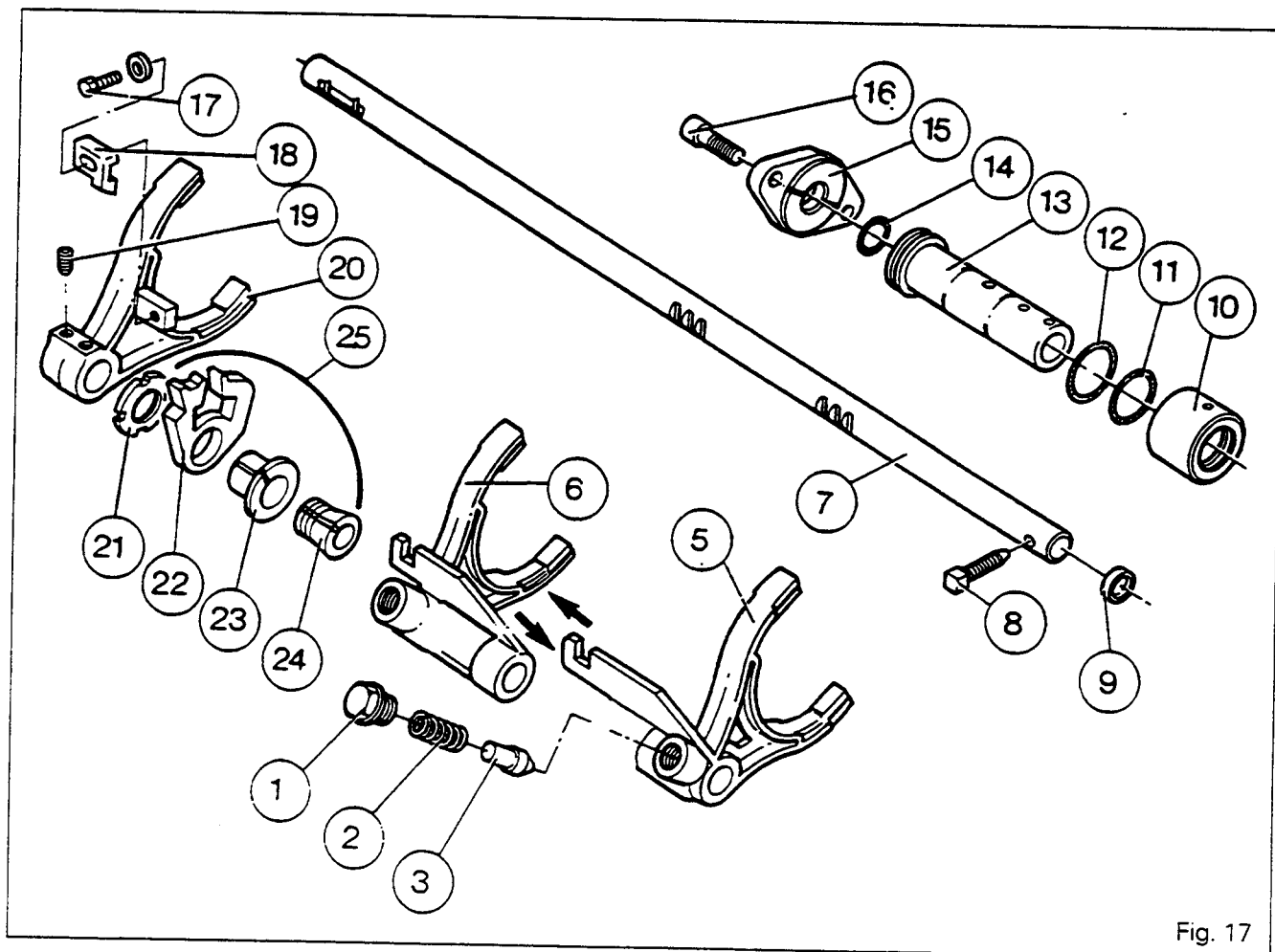

Fig. 17



5E01.10

# 6100 SERIES TRACTORS



## Gearbox - Output shaft

### 74. Adjusting the Hare/Tortoise fork

Principle: The fork (20) is positioned by means of the difference in the spacing between the tapped holes **Y** and the spacing **Z** of the spot-facing marks in the piston (13). The fork can be adjusted to move to different positions by acting on either the front or rear screw, depending on the adjustment required (Fig. 18). Set the control piston (13) and synchromesh (31) to the high range (Hare).

76. Hold the synchromesh against the high range gear (29). (See Fig. 19).

77. Adjust the position of the fork (20) by acting on the two adjusting screws (19) after cleaning them with solvent and coating them with Loctite 221, in order to obtain a play of **J1 = 0.3 mm** between the rear face of the pad and the synchromesh slide rod (Figures 19 and 20).

**Note: Perform the setting using a locally manufactured tool.**

78. Set the control piston (13) and the synchromesh to the low range (Tortoise).

79. Check that there is a play of **J2 = 0.3 min.** (value determined by setting J1) between the pad and the synchromesh slide rod, with the slide rod resting against the low range gear (36) (Fig. 21). Tighten the screws to a torque of 35 Nm without modifying the setting.

**Note: In the Tortoise position, play J1 must be increased if face X of the pad on fork (20) is bearing against the synchromesh slide rod (Fig. 21).**

80. Set the fork to the Tortoise position.

81. Slightly loosen the castellated nut (21). Apply a moderate coat of Loctite 270 on the thread of cone (24).

82. Place the forks in the neutral position.

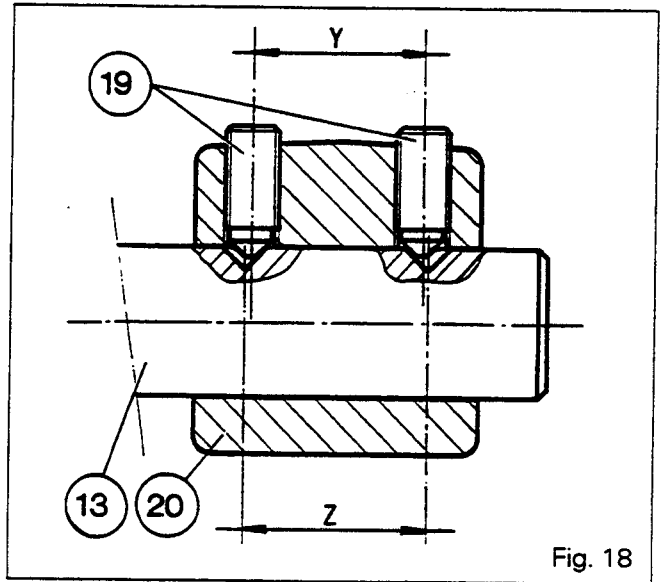

Fig. 18

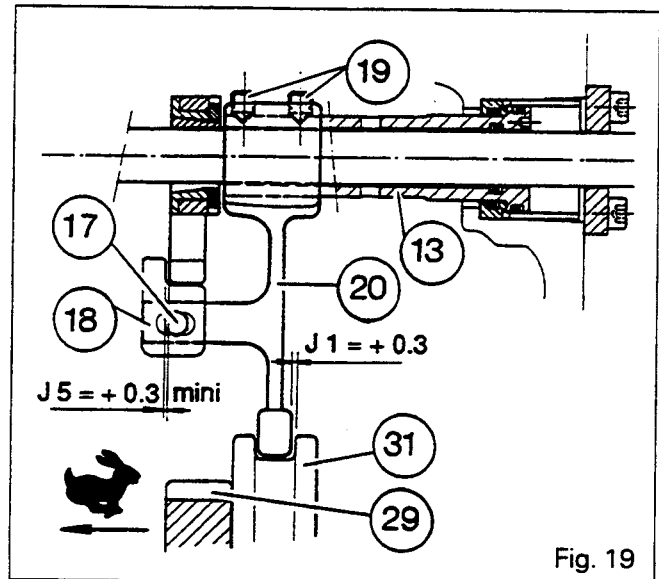

Fig. 19

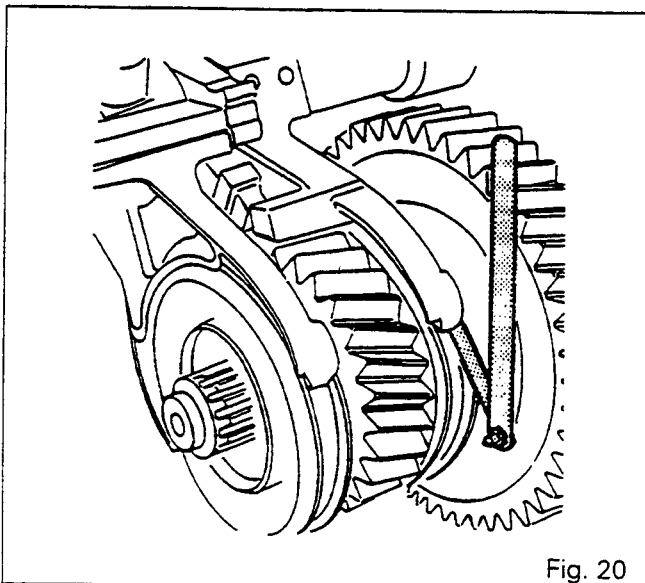

Fig. 20

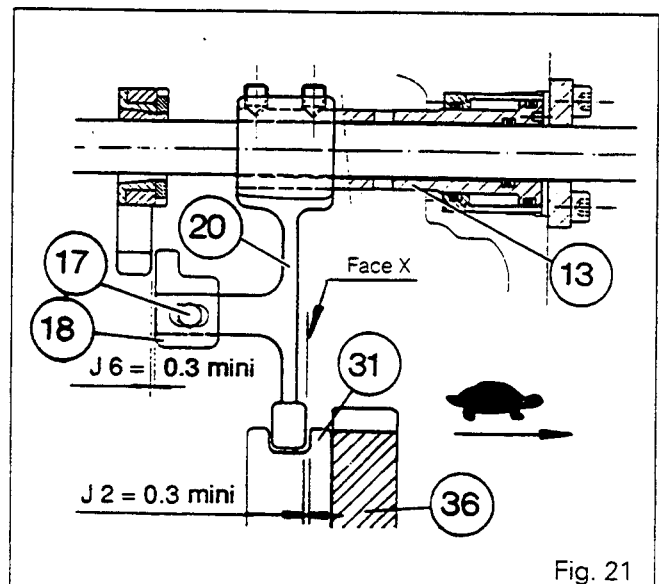

Fig. 21



## Gearbox - Output shaft

83. Adjust the plays J3 and J4 (min. = 0.3 mm) evenly so that the mechanical lock (22) operates freely (Figures 22 and 23).
84. Tighten the castellated nut (21) to a torque of 50 Nm using a spanner 3615334 M1 and a spring scale (Fig. 23).
85. Apply Loctite 648 on the tightening face of the slider (18) and Loctite 241 on bolt (17). Fit the washer and the bolt.
86. Adjust plays J5 and J6 (min. = 0.3 mm) evenly between the slider and the lock in the Hare and Tortoise positions (Figures 19 to 21 and 24).
87. Tighten the bolt to a torque 36 - 46 Nm.
88. Check the operation of the Hare/Tortoise range and the lock.
89. Check the changing of the gears.

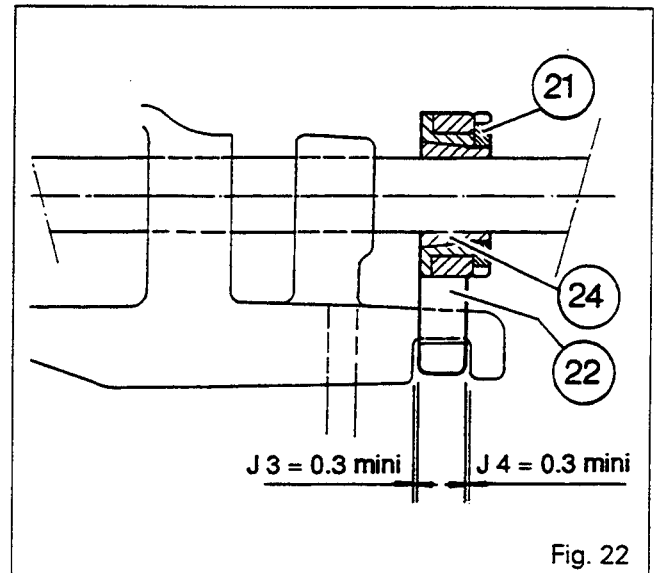

Fig. 22

### G. Refitting the selector cover

90. Fit the bolt (1) (Fig. 13), if fitted, see section 5 C01 or 5 C02 in according to version.  
**Note: If the setting of the sleeves on the levers is required, repeat part E, Section 5 C01.**

### H. Final operations

91. Recouple the tractor between the gearbox and the rear axle, as per Section 2 B02.
92. Check :
  - the systems for leaks,
  - the operation of the electrical circuits.
93. Carry out a road test on the controls.
94. Check for leaks on the mating faces of the selector cover and of the gearbox on the rear axle.

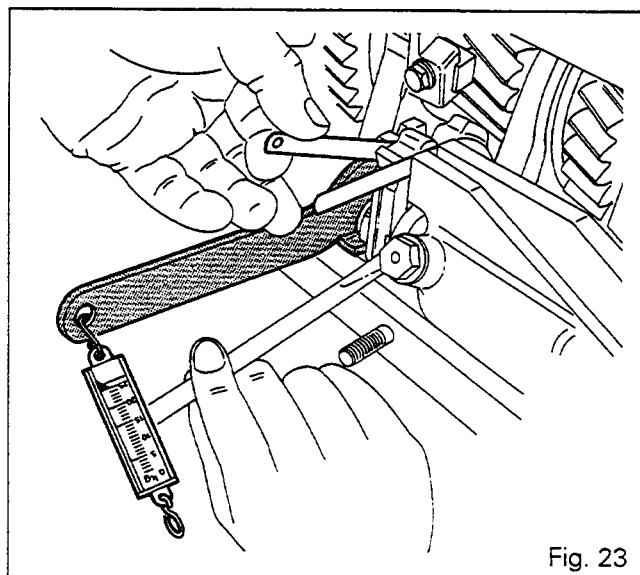

Fig. 23

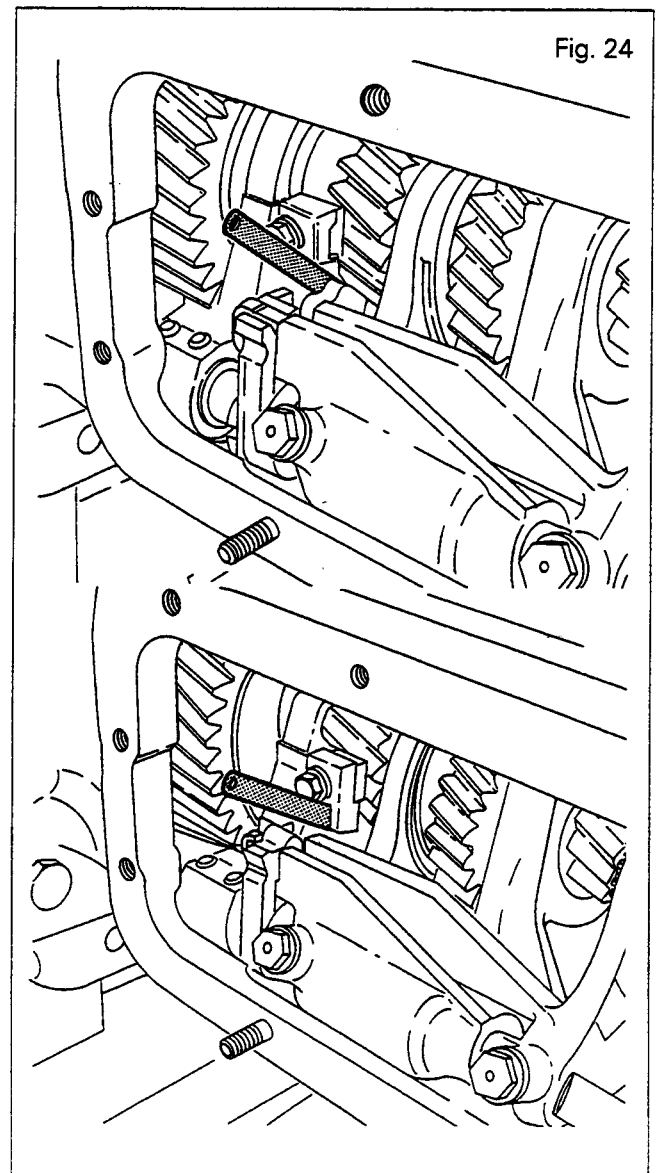
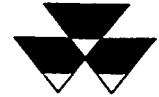

Fig. 24



5E01.12

6100 SERIES TRACTORS



**Gearbox - Output shaft**

**I. Service tools**

a) Tools available from the MF network

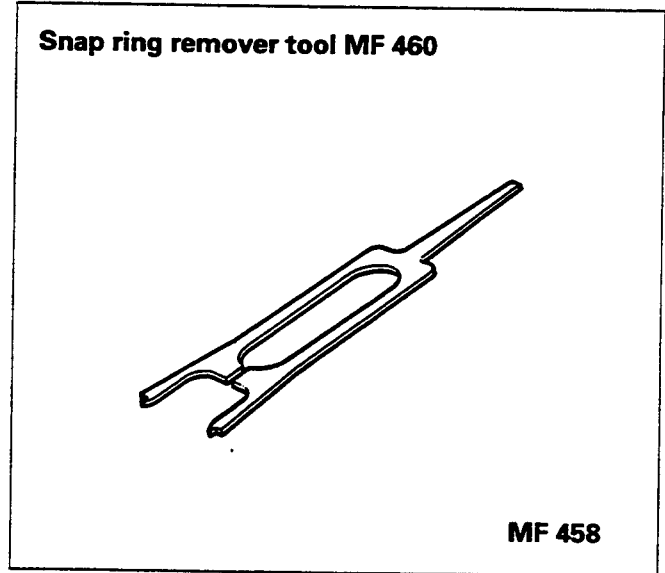
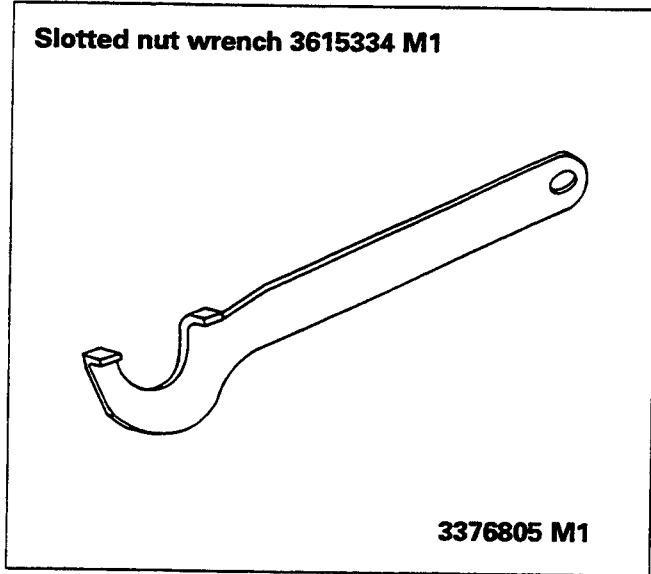

b) Tool to be manufactured locally

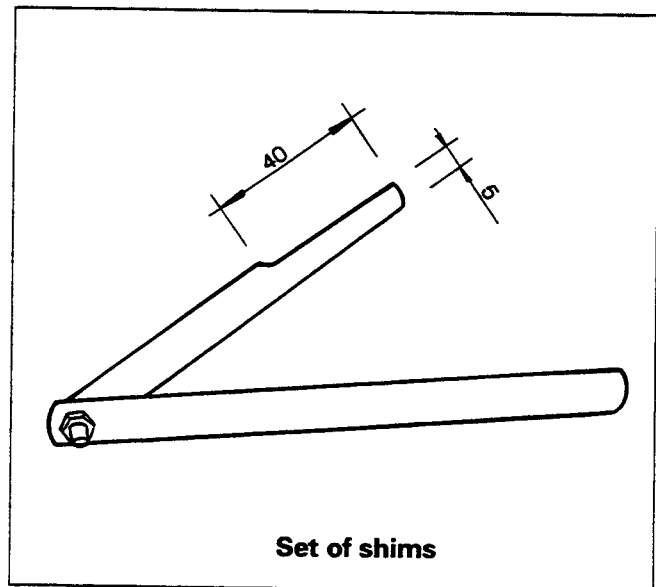
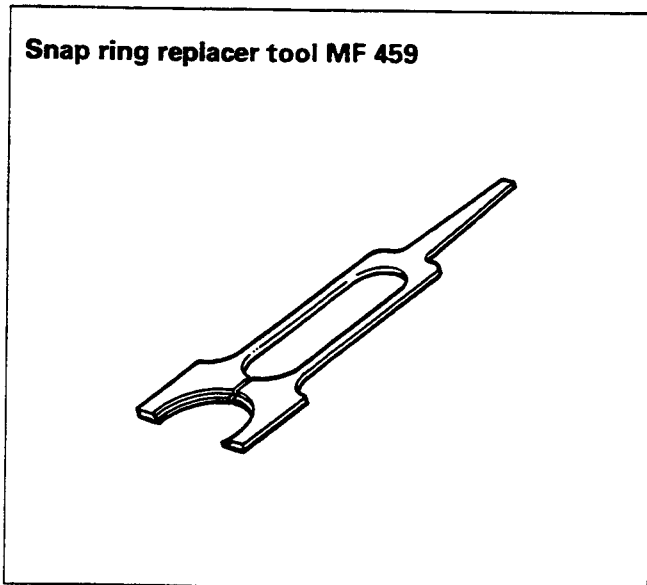



## **Heavy duty gearbox - Output shaft**

5E02.1

### *5 E02 Output shaft*

#### CONTENTS

- <b>General</b> _____	<b>2</b>
<b>A. Preliminary operations</b> _____	<b>4</b>
<b>B. Removing the selector cover</b> _____	<b>4</b>
<b>C. Disassembling the guide rail and selector forks</b> _____	<b>4</b>
<b>D. Disassembling the output shaft</b> _____	<b>4</b>
<b>E. Reassembling and shimming the output shaft</b> _____	<b>5</b>
<b>F. Reassembling the guide rail and selector forks</b> _____	<b>8</b>
<b>G. Refitting the selector cover</b> _____	<b>8</b>
<b>H. Final operations</b> _____	<b>8</b>
<b>I. Service tools</b> _____	<b>9</b>





5E02.2

## 6100 SERIES TRACTORS

**Heavy duty gearbox - Output shaft****General**

The characteristics of the heavy duty gearbox are similar to those of the standard gearbox.

The front end of the reinforced gearbox is supported by a bearing (24) with needle rollers with a larger cross section.

Bearings (28) and (30), separated by a spacer (80), allow the driving gear (29) to rotate on the output shaft. Bearings (79) and (81) act as end stops.

A dual cone synchromesh is used to change the speed range between the Hare and Tortoise (Hi/Lo) gears, (29) and (36) respectively.

For shim setting J3, the preloading or play between the cones and their respective cups is adjusted according to the thickness of the circlip (49).

Shim settings J4 and J5 are the same as for the version used on standard gearboxes.

**List of parts**

- (24) Needle-roller bearing  
 (27) Washer  
 (28) Needle-roller bearing

- (29) 3rd speed driving gear (Hare)  
 (30) Needle-roller bearing  
 (31) Hare/Tortoise dual cone synchromesh  
 (32) Washer  
 (35) Bush  
 (36) Tortoise gear  
 (37) Bearing cup  
 (38) Shim(s)  
 (39) Bearing cone  
 (40) Bearing cone  
 (41) Bolt  
 (42) Shim(s)  
 (43) Packing shim  
 (44) Output shaft  
 (45) Circlip  
 (46) Locking ring  
 (48) Bearing cup  
 (49) Circlip  
 (79) Needle-roller bearing  
 (80) Spacer  
 (81) Needle-roller bearing

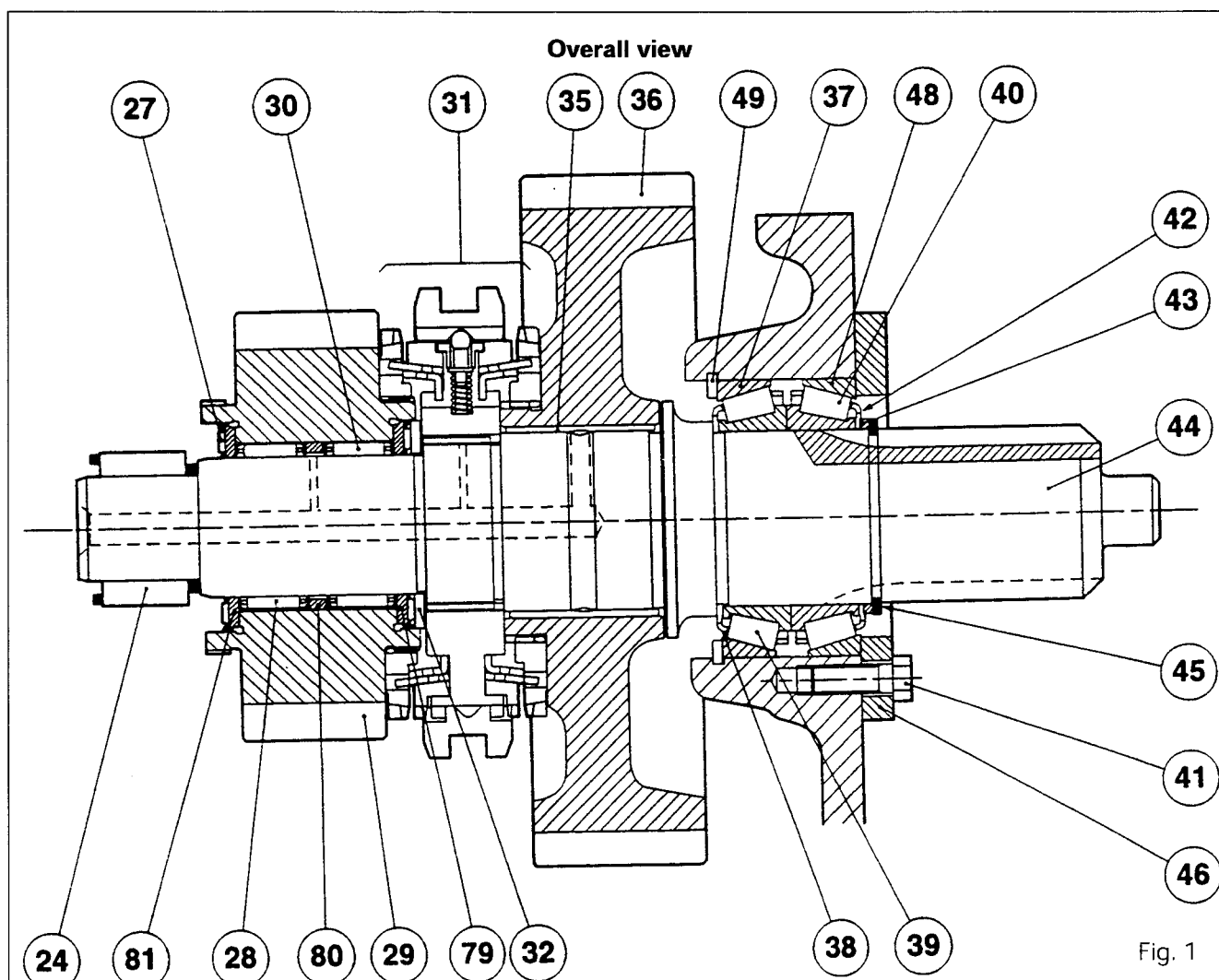



# Heavy duty gearbox - Output shaft

5E02.3

Exploded view

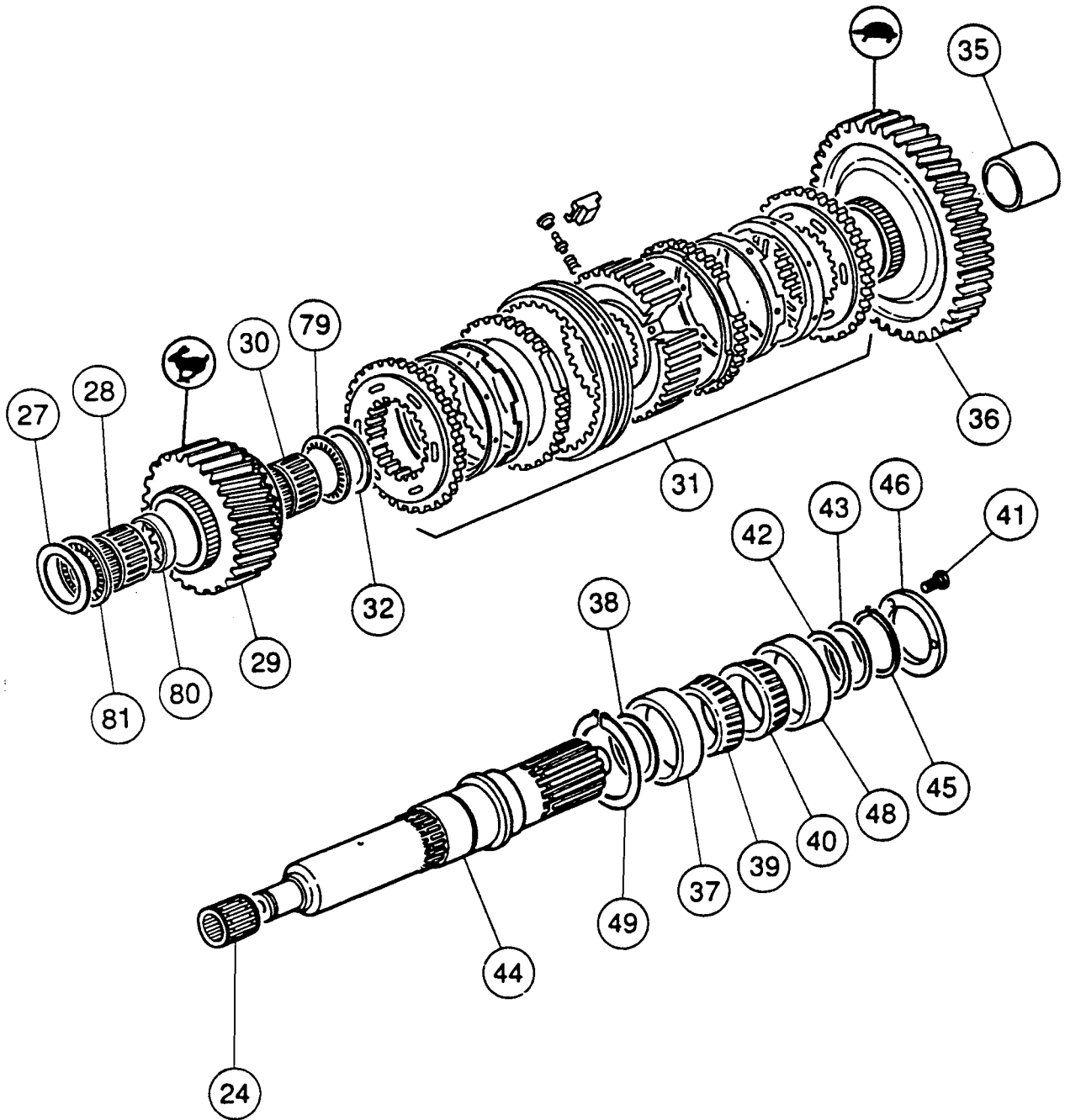

Fig. 2



5E02.4

---

## 6100 SERIES TRACTORS

---



# Heavy duty gearbox - Output shaft

---

## A . Preliminary operations

---

1. Split the tractor between the gearbox and the rear axle (as per Section 2B01).

---

## B . Removing the selector cover

---

2. See Section 5C01 or 5C02, according to version.

---

## C . Removing the guide rail and forks

---

3. See Section 5D01.

---

## D . Removing the output shaft

---

**Note : Remove the creeper gearbox if the tractor is fitted with one.**

4. Move the three bolts (41).
5. Remove the locking ring (46).
6. Remove the bearing cup (48).
 

**Note : Keep the cones and cups in pairs if they are to be re-used.**
7. Remove the circlip (45).
8. Remove the packing shim (43) and the adjusting shims (42).
9. Remove the bearing cone (40).
10. Remove the cone (39).
11. Remove the shims (38).
12. Pull the shaft (44) towards the rear and remove it.
13. Through the opening in the selector cover, take out the synchromesh (31), the Hare/Tortoise synchromesh rings, the gear (29), the 3rd speed synchro ring, the two needle-roller bearings (79) and (81), the two thrust washers (27) and (32) and the Tortoise gear (36).
14. Remove the cup (37) and circlip (49).
15. Remove the needle-roller bearing (24), and mark the direction of fitting.



## Heavy duty gearbox - Output shaft

5E02.5

### E . Reassembling and shimming the output shaft

16. Check and clean the parts, and replace any that are faulty.
17. Reinstall the needle-roller bearing (24), in the bore in the mainshaft, with the small diameter on the flexible bush facing the 3rd speed driving gear (Hare) (29) (Fig. 3).
18. Engage the shaft in the housing without gears.
19. Fit a circlip (49) of minimum thickness.
20. Fit the cup (37).

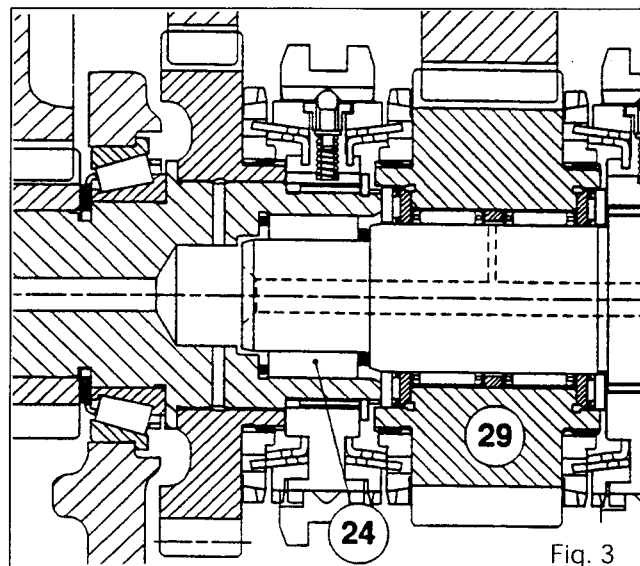

Fig. 3

### Preparation for shim setting J3 (Fig. 4)

21. Slide the cones (39) and (40) and hold them fully home against the shoulder of shaft (44) by pressing on them by hand. Fill the gap Y between the rear of the cone (40) and the groove for circlip (45) with shims (42) and packing shim (43). Choose a new circlip that provides a slightly tight fit in the groove (Fig. 5).

**Note : Fit the packing shim (43) against the circlip (45).**

22. Fit the cup (48) and the locking ring (46).  
Tighten the bolts (41) to a torque of 27 to 32 Nm.

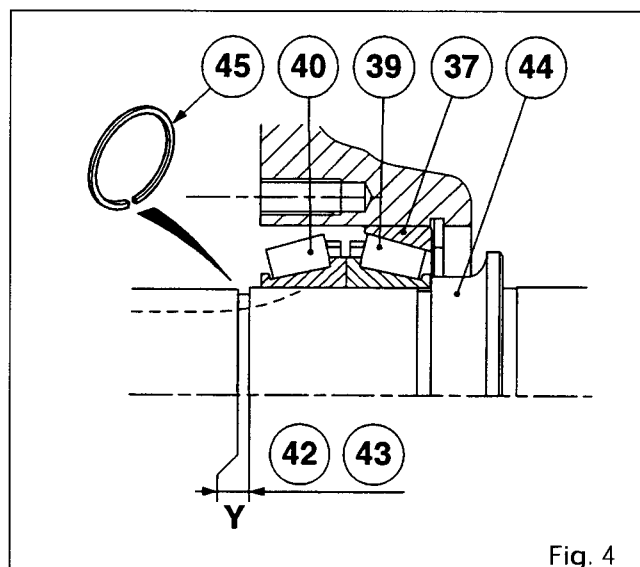

Fig. 4

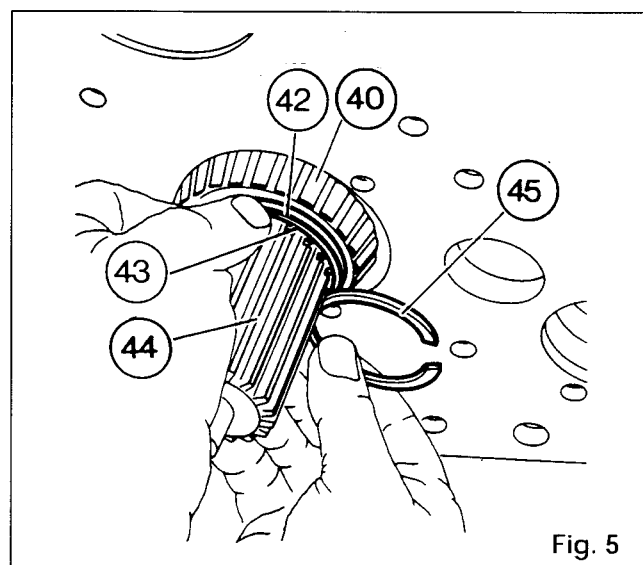

Fig. 5



5E02.6

## 6100 SERIES TRACTORS

**Heavy duty gearbox - Output shaft****Setting J3**

23. Position the pointer of a dial gauge on the end of the shaft (44) (Fig. 7).

**Note:** In the case of gearboxes equipped with creeper gears, use the gearbox locking ring (Fig. 8) in place of the locking ring. Tighten the bolts to a torque of 34 to 52 Nm.

24. Push on the shaft while turning it alternately clockwise and anticlockwise in order to seat the cones correctly in the cups.

25. Reset the dial gauge to zero.

26. Repeat procedure 24 while pulling on the shaft.

27. If the end play measured is greater than 0.05 mm, determine the thickness of circlip (49) required to obtain J3 (Fig. 6).

28. Remove the circlip (45).

29. Remove the packing shim (43) and the adjusting shims (42).

30. Remove the bolts (41) and the locking ring (46).

31. Remove cup (48), cones (40) and (39), keeping the cups and cones in pairs, cup (37), the circlip (49) and the shaft (44).

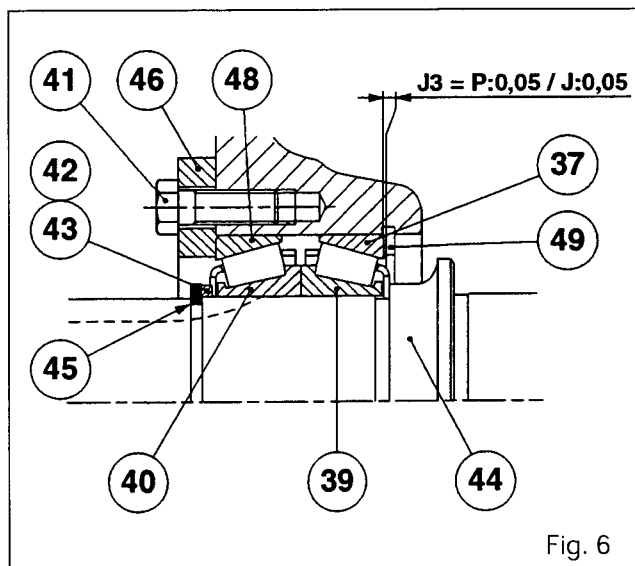

Fig. 6

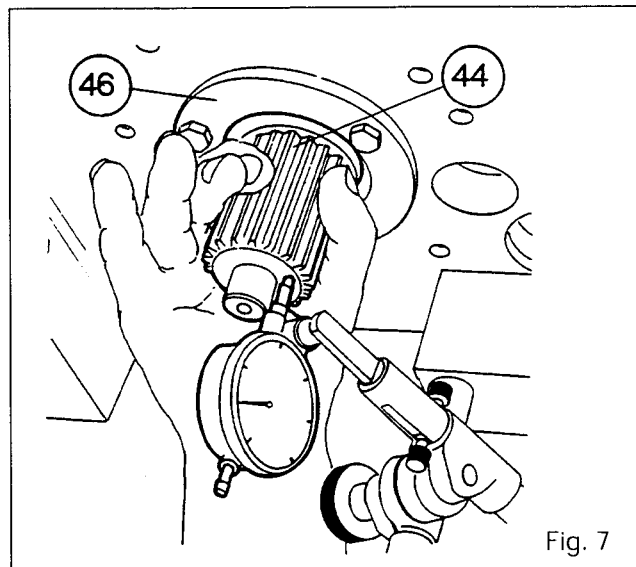

Fig. 7

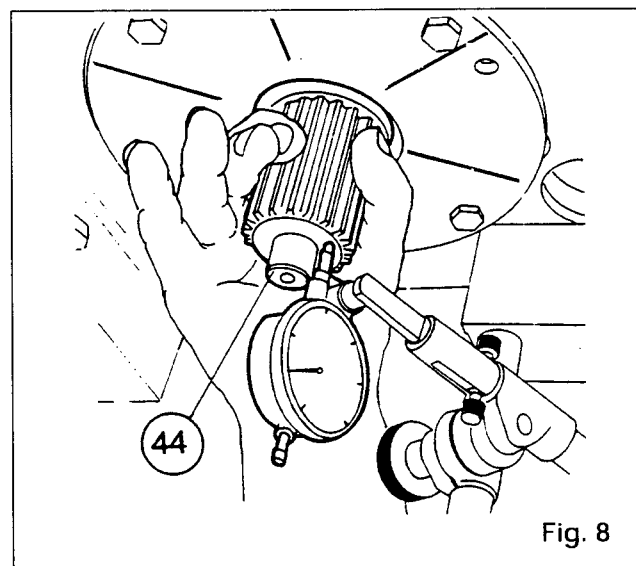

Fig. 8



## Heavy duty gearbox - Output shaft

### Fitting the gears and shaft

32. On a bench, pre-assemble the 3rd speed driving gear (29) with its synchro rings, bearings (79) and (81), washers (27) and (32) and synchromesh (31).
33. In the housing, install the Tortoise gear (36) with its synchro ring, the 3rd speed driving gear (29) (with recess "R" or groove "G" facing the 3rd - 4th speed synchromesh (Fig. 9A) and the synchromesh (31).  
**Note : If bush (35) is damaged, replace the gear assembly (and rebores the bush after fitting). The needle-roller bearings (28) and (30) are separated by a spacer (80).**
34. Engage the output shaft (44) while holding the gear assembly (Fig. 9B).

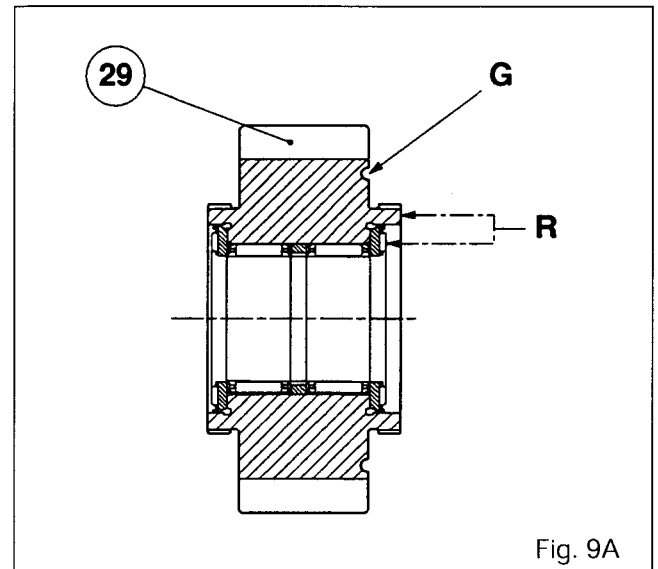

Fig. 9A

### Setting J4

35. Fit the circlip (49) defined in procedure 27.  
Slide the cones and cups paired in procedure 31 onto the shaft.
36. Fit the locking ring (46). Tighten the bolts (41) to a torque of 27 to 32 Nm.
37. Position the pointer of a dial gauge on the end of the shaft (44) (Fig. 7).  
**Note : In the case of gearboxes equipped with creeper gears, use the gearbox locking ring (Fig. 8) in place of the locking ring. Tighten the bolts to a torque of 34 to 52 Nm.**
38. Push on the shaft while turning it alternately clockwise and anticlockwise in order to seat the cones correctly in the cups.
39. Reset the dial gauge to zero.
40. Repeat procedure 38 while pulling on the shaft.  
According to the measurement read on the dial gauge, determine the thickness of shims Z (38) to obtain play J4 (Fig. 10).
  - Remove the bolts (41) and the locking ring (46).
  - Remove the cup (48).
  - Withdraw the cones (40) and (39).
  - Slide the following components onto the shaft: the required thickness of shims Z (38), cone (39) and cone (40).

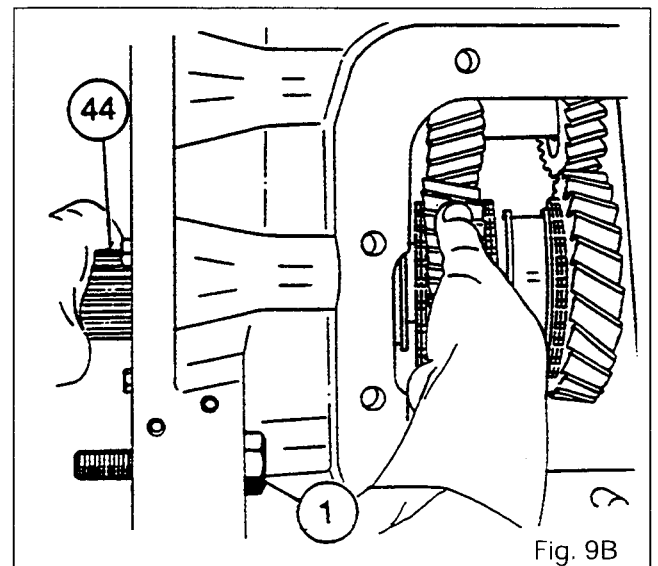

Fig. 9B

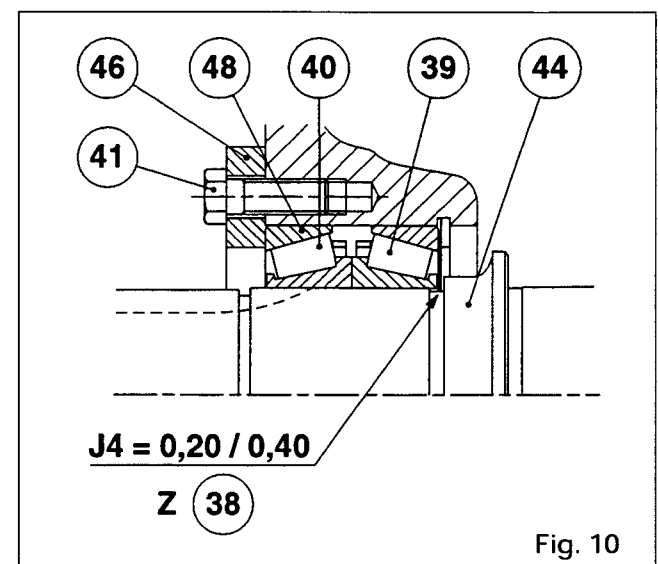

Fig. 10



5E02.8

## 6100 SERIES TRACTORS

**Heavy duty gearbox - Output shaft****Setting J5**

41. Perform the shimming (Fig. 1) to obtain:

**J5 = no end play**

42. Use the thickness of shims **Y (42)** and **(43)**, measured in procedure 21, to deduce the thickness of shims **Z (38)** to obtain:

**J5 = Y - Z.**

43. Fit the cup **(48)** and the locking ring **(46)**.

Tighten the bolts **(41)** to a torque of 27 to 32 Nm.

44. Slide the thickness of shims selected in procedure 42 onto the shaft.

45. Fit the circlip **(45)**.

**Note : Position the packing shim (43) on the circlip side.**

The circlip must be a slightly tight fit in its groove. Check that it is correctly positioned.

**Note : Refit the creeper gearbox (if fitted).**

46. Check by hand that the shaft and its gears turn freely.

47. Check that the 3rd - 4th and Hare/Tortoise synchromeshes operate normally.

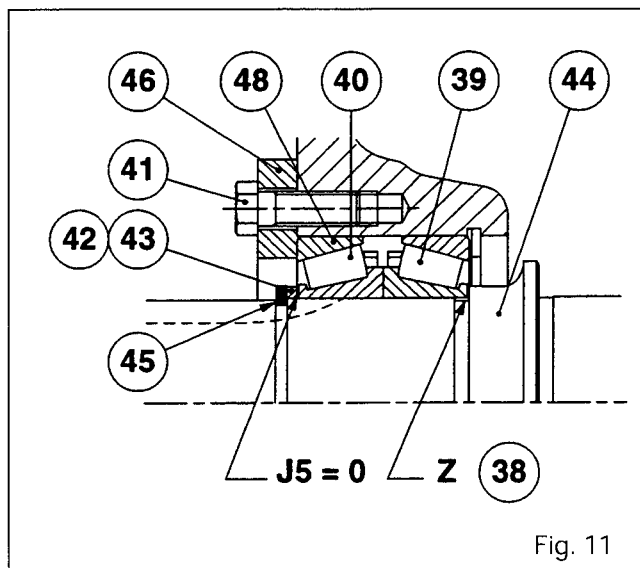

Fig. 11

**F . Reassembling the guide rail and forks**

See Section 5D01.

**G . Refitting the selector cover**

48. Fit the bolt **(1)** (Fig. 9, Section 5C01) if it was removed. Reinstall the cover (as per Section 5C01 or 5C02 according to version).

**Note : If the setting of the sleeves on the levers is required, repeat Part E of Section 5C01 or Part C of Section 5C02.**

**H . Final operations**

49. Recouple the tractor between the gearbox and the rear axle (as per Section 2B01).

50. Check:

:

51. Carry out a road test on the controls.

52. Check for leaks on the mating faces of the selector cover and of the gearbox on the rear axle.



# Heavy duty gearbox - Output shaft

5E02.9

## I. Service tools

1. Tool available from the MF network  
**3615334M1 - Slotted nut wrench for Hare /  
Tortoise latch**

2. Tool to be manufactured locally  
**Shim**

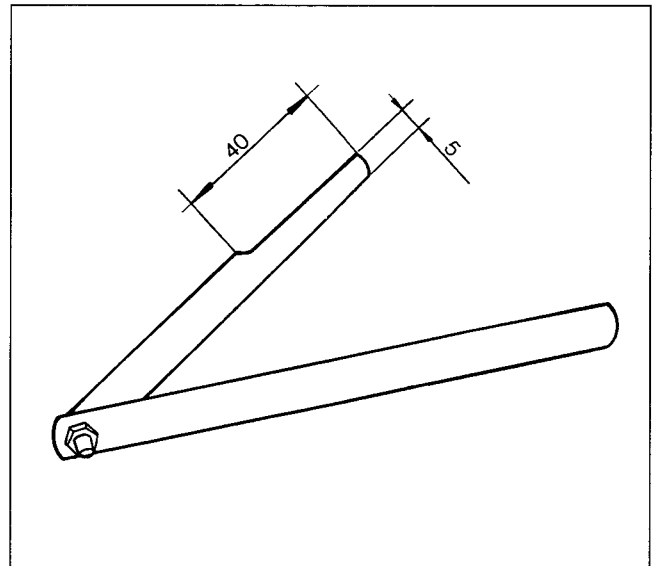
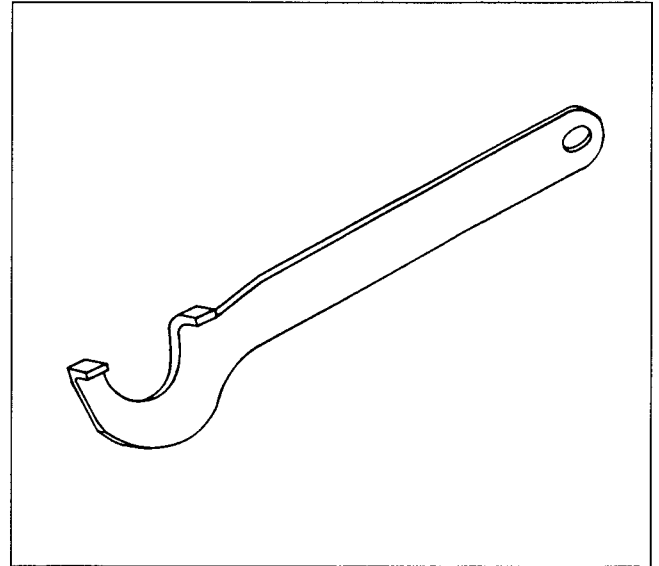







**Gearbox - Layshaft**

5F01.1

*5 F01 Layshaft*

CONTENTS

-	<b>General</b> _____	<b>2</b>
A.	<b>Preliminary operations</b> _____	<b>3</b>
B.	<b>Disassembly</b> _____	<b>3</b>
C.	<b>Reassembly</b> _____	<b>3</b>
D.	<b>Refitting the input gearbox and shimming the layshaft</b> ____	<b>4</b>
E.	<b>Service tool</b> _____	<b>5</b>



5F01.2

# Gearbox - Layshaft

## General

The layshaft and its gears make up the upper drive line of the gearbox. The shaft (54) carries the driven gears for 1st speed (60), 2nd speed (59) 3rd speed (55) and 4th speed (56). The rear set of teeth is constantly meshed with the Tortoise (Lo) gear.

The front of the shaft is carried by the taper roller bearing (63) (64) in the rear of the input gearbox and by a bearing (52) (53) mounted in the bearing at the rear of the gearbox.

The gears (56) and (60) are held in position by spacer (57). End play on the gears is obtained by mounting shims [58] between the gears (59) and (60).

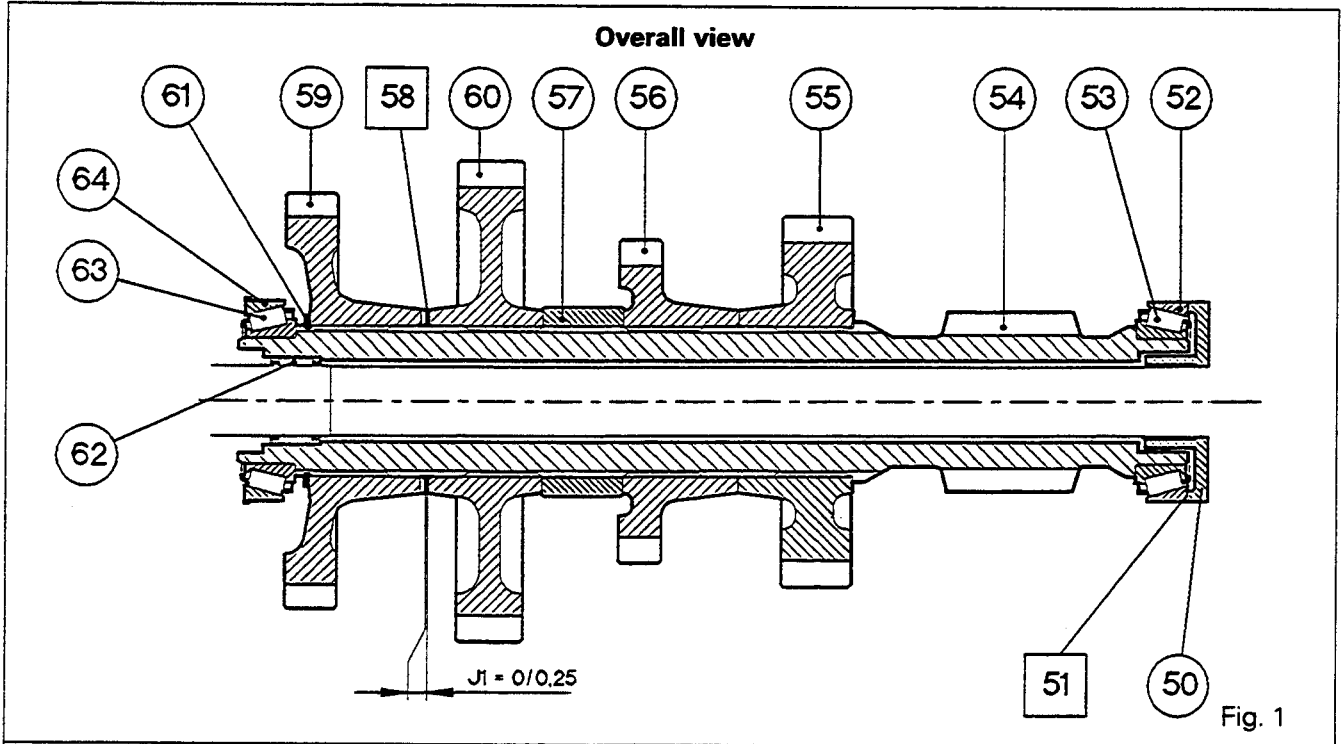

Fig. 1

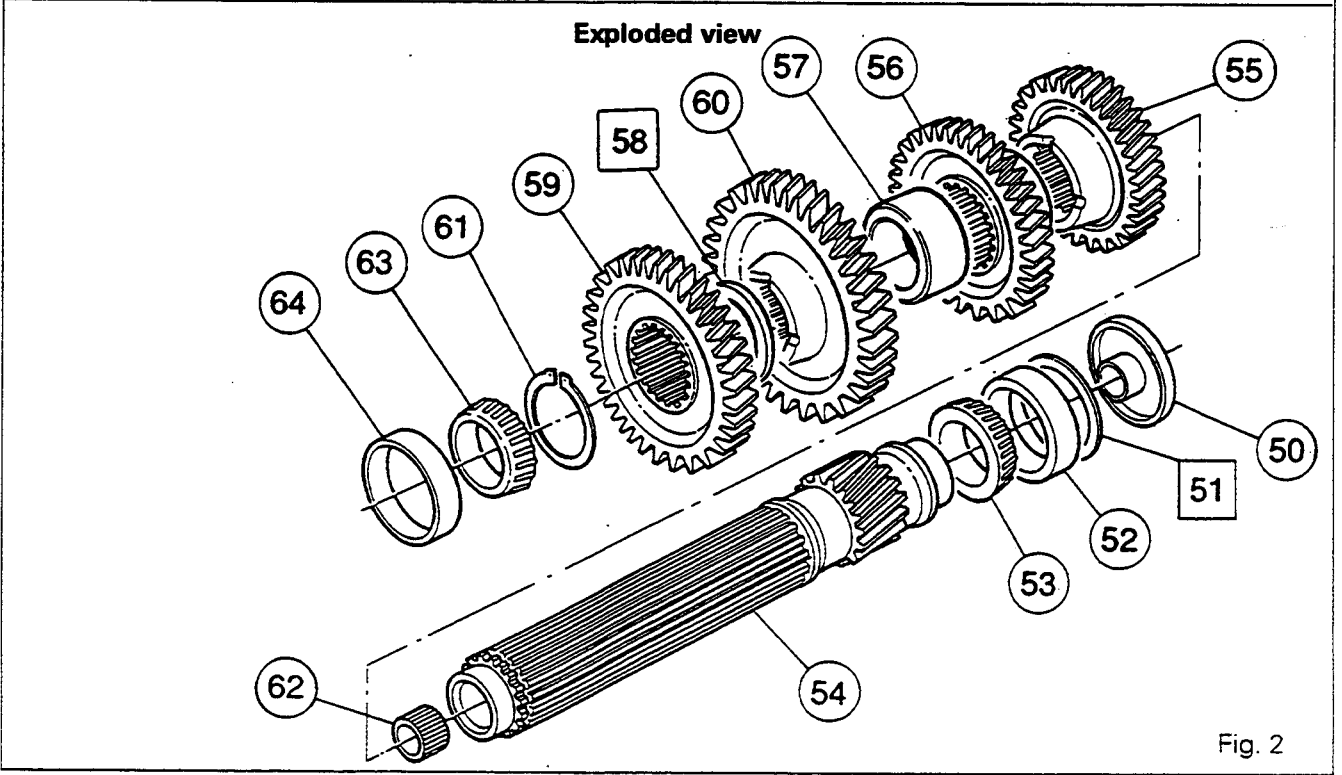

Fig. 2



## Gearbox - Layshaft

### A. Preliminary operations

To allow the bearings to be correctly shimmed when replacing the layshaft the gearbox must be removed.

1. Split the tractor between the gearbox and the rear axle (see Section 2 B01).
2. Separate the gearbox from the engine, section 2 A01.
3. Remove the clutch, see section 4 A01 or 4 B01 according to version.
4. Remove the selector cover, see section 5 C01 or 5 C02 according to version.
5. Remove the input gearbox, see section 5 B01.

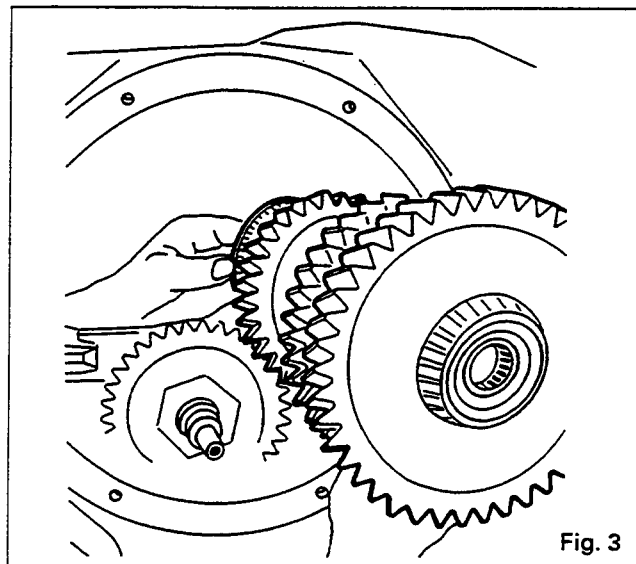

Fig. 3

### B. Disassembly

6. Remove the deflector (50), the shims (51) and the cup (52). Withdraw the shaft assembly (Fig. 3).
7. Extract the bearing cones (53) and (63).  
**Note: Keep the cones and cups in pairs if they are to be re-used.**
8. Remove the circlip (61).
9. Remove the 2nd gear (59), the shims (58), the 1st gear (60) and the spacer (57).
10. Remove the 4th gear (56) and the 3rd gear (55).
11. Drive out the needle-roller bearing (62) and discard it.

18. Remove the circlip (61) and the gear (59).
19. Slide the previously selected shims onto the shaft. Fit the pinion and the circlip.
20. Use the press and a suitable fixture to fit the cones (63) and (53).
21. Reinstall the assembled shaft and the cup (52).

**Note: When replacing the gears, it is not necessary to shim the bearings again. Disassembly of layshaft can be made without removing the gearbox according to the following method.**

### C. Reassembly

12. Clean and check the parts, and replace any that are defective.
13. Fit the needle-roller bearing (62) fully home on the shoulder of the shaft (54), using a press.  
**Note: After this fitting operation, check that the needle-rollers turn normally in the cage.**
14. Reinstall the 3rd gear (55) and the 4th gear (56).
15. Slide the spacer (57) into position. Install the 1st gear (60) and the 2nd gear (59).
16. Fit the circlip (61).
17. Using a set of shims, measure the space between the 1st gear (60) and the 2nd gear (59).  
According to the measurement obtained, use the shim thickness required to obtain a play of:  
**J1 = 0 to 0.25 mm**

### Disassembly

- . Remove the 1st, 2nd plunger and position the lock so as to free the fork.
- . Refer to section 5 A01. Remove lubrication tube (71) and the spring. Loosen nut (68).  
In order to facilitate the disengagement of 1st gear (60) to remove the complete shaft, take out the input gear (67) to the front with its bearing, the 1st, 2nd gears (7) - (14) and the synchromesh.
- . Remove the gears (see § B).

### Reassembly

- . Reverse the disassembly operations. Replace nut (68) as described section 5 G01.
- . Tighten the plunger plug to a torque of 50 - 70 Nm.
- . Check the axial play of the 1st - 2nd gears and the synchromesh operation.



## Gearbox - Layshaft

### D. Removing the input gearbox and shimming the layshaft

22. Remove the input gearbox, see section 5 B01.
23. Shim the layshaft (see Fig. 4) to obtain a play of:  
**J2 = 0.04 to 0.12 mm** (Fig. 5)
24. Install the locally manufactured tool (see Section E) in the layshaft (Fig. 6).
25. Compress the spring moderately by tightening the nut on the tool in order to bed the cones correctly in the cups.
26. Rotate the shaft through a few turns.
27. Using a depth gauge, measure the dimension **X** between face **A** of the cup (52) and face **B** on the housing (see Fig. 5).
28. Measure the thickness **Y** of the deflector (50).
29. Calculate the difference between **X** and **Y**.
30. Determine the shim thickness required to obtain a play **J2**.
31. Remove the compression tool.
32. Position the shims [51] selected in procedure 30.
33. Fit the deflector in the housing.
34. Adjust the reversing selector, see section 5 B04.  
Refit the selector cover, see section 5 C01 or 5 C02 according to version.  
**Note: Do not forget to fit the bolt (1) on the housing (Fig. 9), section 5 C01.**
35. Recouple the gearbox with the engine, see section 2 A01.
36. Recouple the tractor between the gearbox and the rear axle (Section 2 B01).
37. Check :
  - the systems for leaks
  - the operation of the electrical circuits.
38. Carry out a road test on all the controls.
39. Check the unions and mating faces for leaks (selection cover, and gearbox on rear axle).

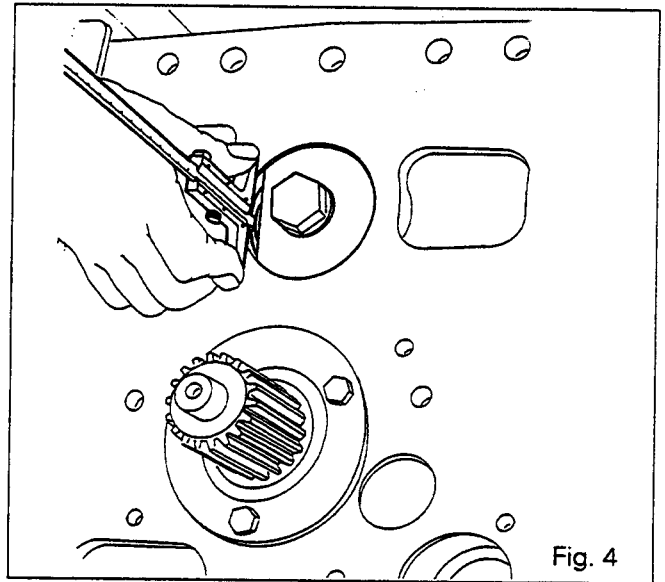

Fig. 4

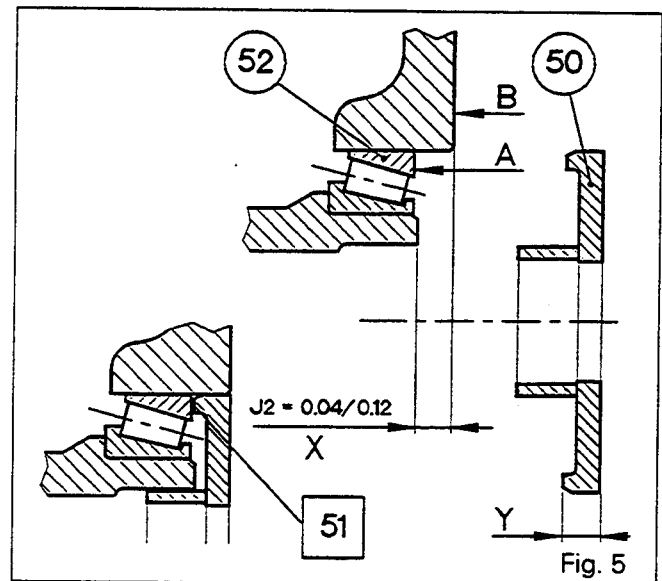
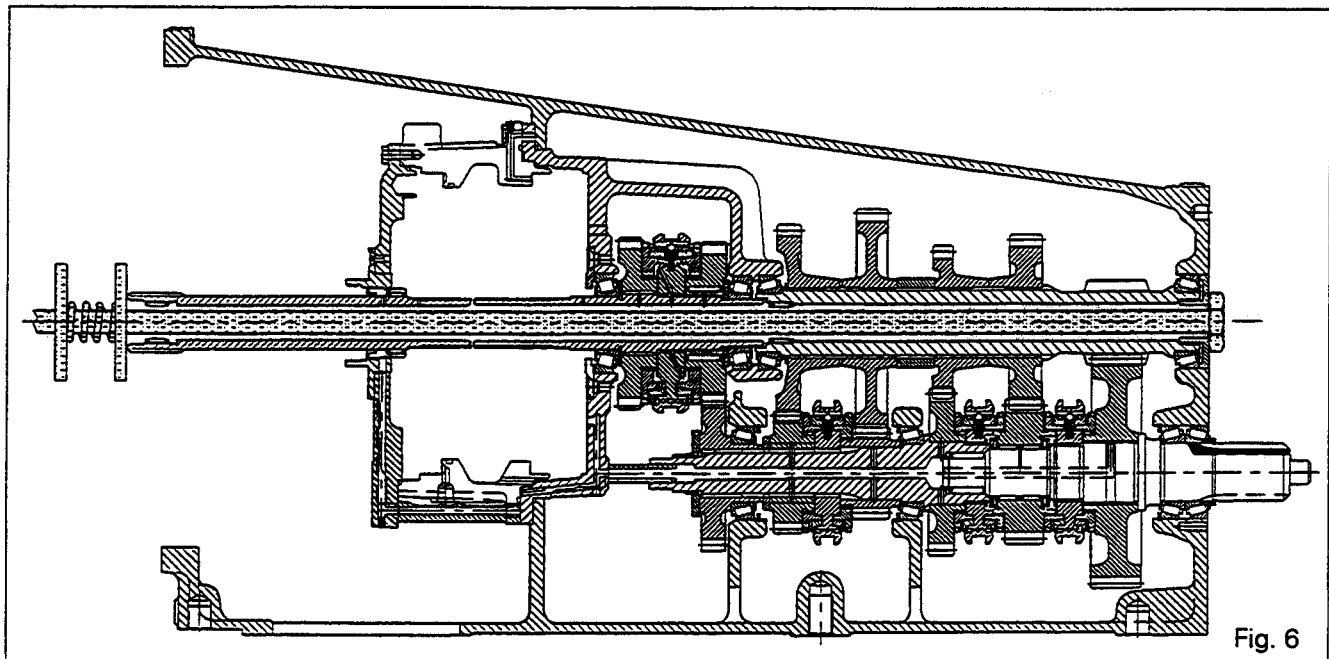

Fig. 5



# Gearbox - Layshaft



## E. Service tool

Layshaft holding tool, to be manufactured locally.

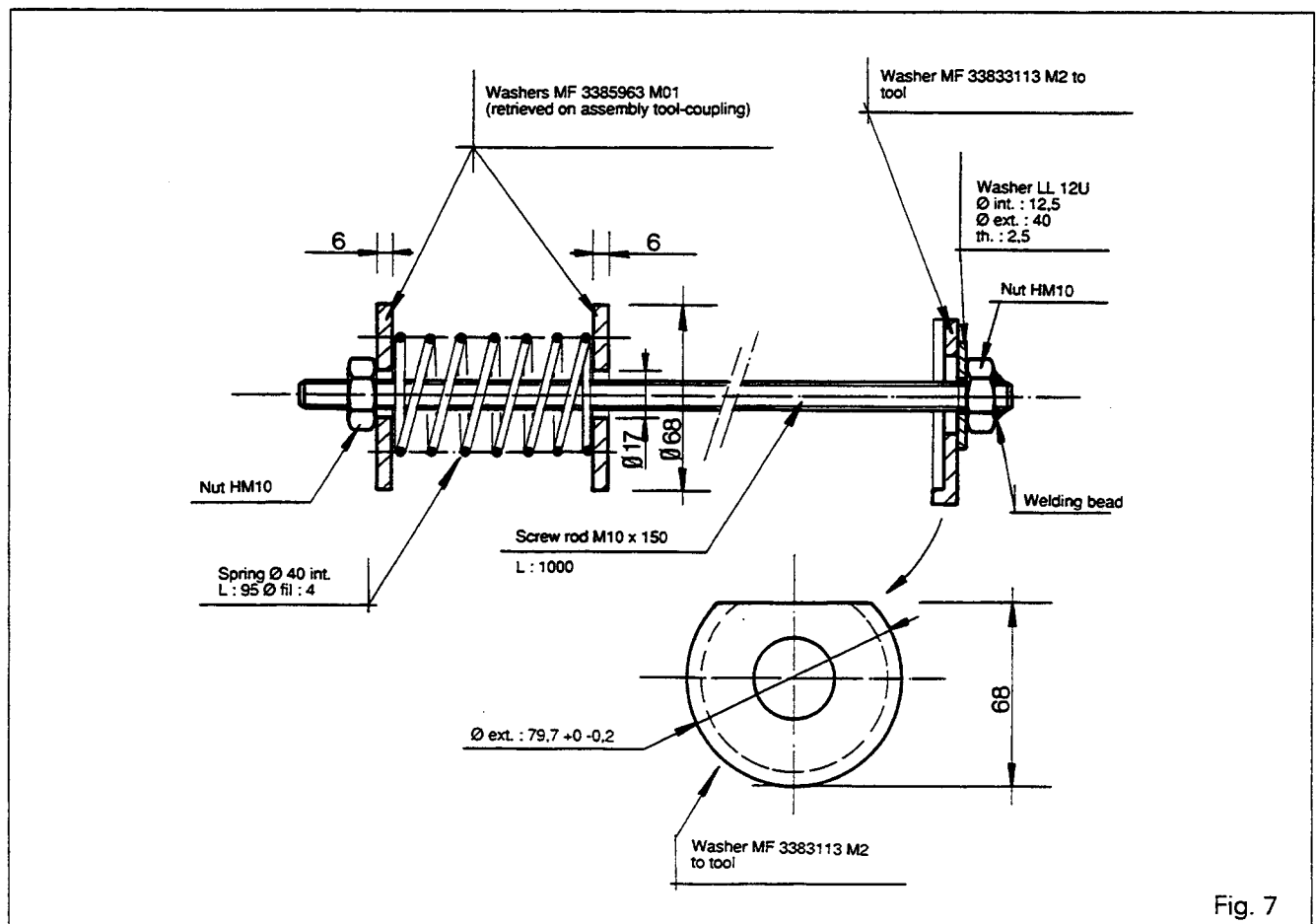



**Heavy Duty gearbox - Intermediate shaft**

5F02.1

**5F02 Layshaft**

## CONTENTS

-	<b>General</b> _____	<b>2</b>
A.	<b>Preliminary operations</b> _____	<b>3</b>
B.	<b>Disassembly</b> _____	<b>3</b>
C.	<b>Reassembly</b> _____	<b>3</b>
D.	<b>Refitting the input gearbox and shimming the layshaft</b> ____	<b>4</b>
E.	<b>Service tool</b> _____	<b>5</b>





## 6100 SERIES TRACTORS



5F02.2

### Heavy Duty gearbox - Intermediate shaft

#### General

The layshaft gears of the Heavy Duty gearbox have a different profile from those of the standard gearbox. The width of gears (55), (56) and (60) is greater. The rear teeth that are constantly meshed with the Tortoise gear are strengthened. The flange on gears (55) and (56) has been replaced by a spacer (82). The shimming of the layshaft gears remains unchanged.

- (54) Layshaft
- (55) 3rd driven gear
- (56) 4th driven gear
- (57) Spacer
- (58) Shim(s)
- (59) 2nd driven gear
- (60) 1st driven gear
- (61) Circlip
- (62) Needle-roller bearing
- (63) Bearing cone
- (64) Bearing cup

#### List of parts

- (50) Deflector
- (51) Shims
- (52) Bearing cup
- (53) Bearing cone

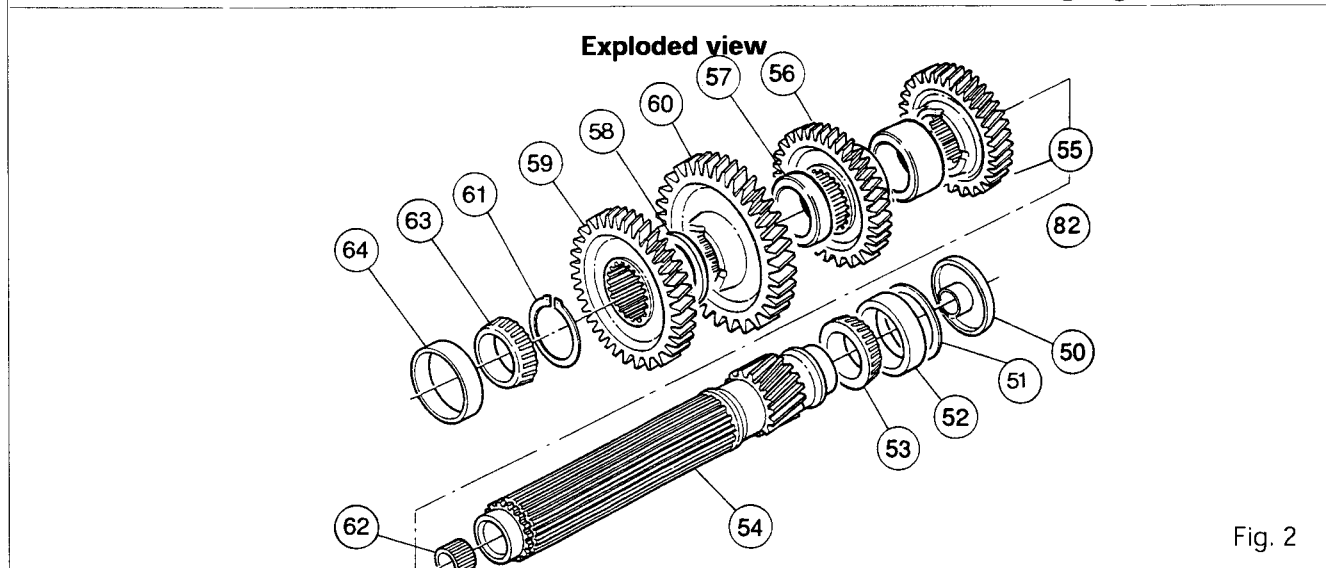
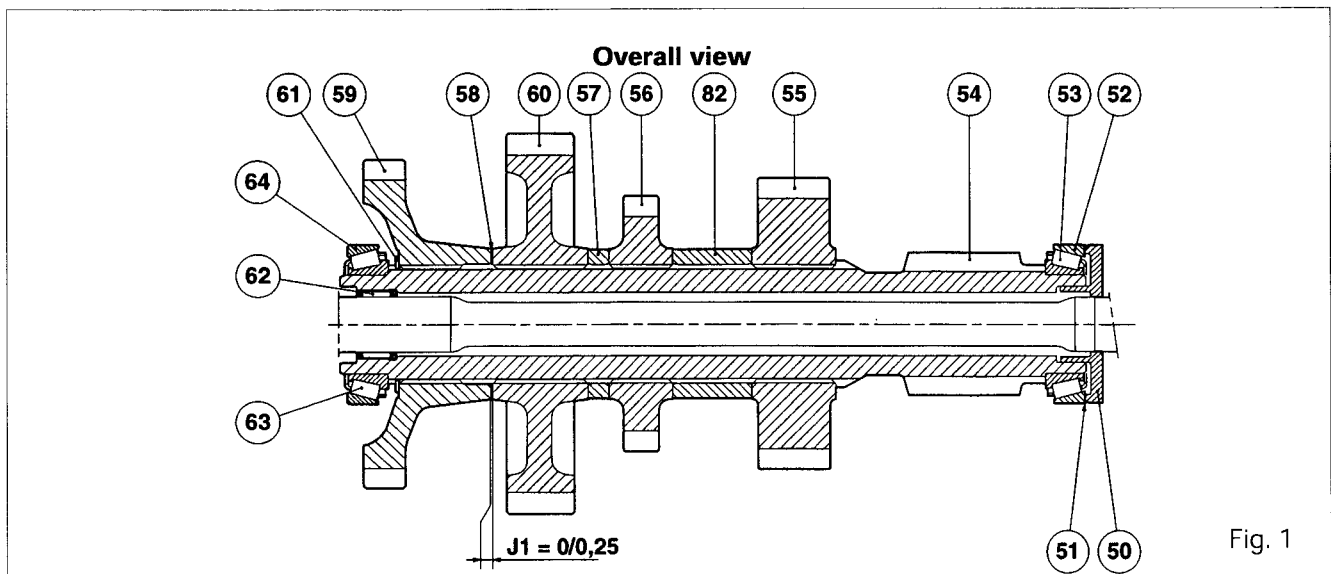



## Heavy Duty gearbox - Intermediate shaft

5F02.3

### A . Preliminary operations

In order to ensure that the bearings are correctly shimmed when replacing the layshaft, the gearbox must be removed.

1. Split the tractor between the gearbox and the rear axle (see Section 2 B01).
2. Separate the gearbox from the engine (see Section 2 A01).
3. Remove the clutch (see Section 4 A01).
4. Remove the selector cover (see Section 5 C01 or 5 C02 according to the version).
5. Remove the input gearbox (see Section 5 B01).

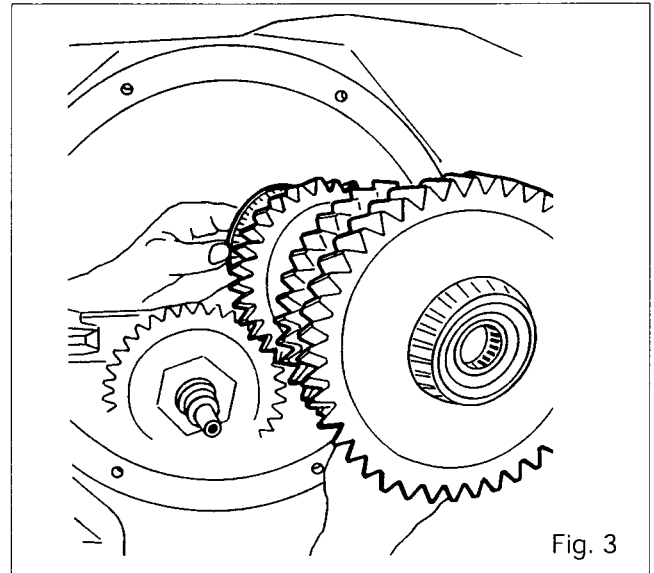

Fig. 3

### B . Disassembly

6. Remove the deflector (50), the shims (51) and the cup (52). Withdraw the shaft assembly (Fig. 3).
7. Extract the bearing cones (53) and (63).  
**Note : Keep the cones and cups in pairs if they are to be re-used.**
8. Remove the circlip (61).
9. Remove the 2nd gear (59), the shims (58), the 1st gear (60) and the spacer (57).
10. Remove the 4th gear (56), the spacer (82) and the 3rd gear (55).
11. Drive out the needle-roller bearing (62) and discard it.

18. Remove the circlip (61) and the gear (59).
19. Slide the previously selected shims onto the shaft. Fit the pinion and the circlip.
20. Use the press and a suitable fixture to fit the cones (63) and (53).
21. Reinstall the assembled shaft and the cup (52).

### C . Reassembly

12. Clean and check the parts, and replace any that are defective.
13. Fit the needle-roller bearing (62) fully home on the shoulder of the shaft (54), using a press.  
**Note : After this fitting operation, check that the needle-rollers turn normally in the cage.**
14. Reinstall the 3rd gear (55), the spacer (82) and the 4th gear (56).
15. Slide the spacer (57) into position. Install the 1st gear (60) and the 2nd gear (59).
16. Fit the circlip (61).
17. Using a set of shims, measure the space between the 1st gear (60) and the 2nd gear (59). According to the measurement obtained, use the shim thickness required to obtain a play of :  
**J1 = 0 to 0.25 mm** (see Fig. 1)



5F02.4

## 6100 SERIES TRACTORS

**Heavy Duty gearbox - Intermediate shaft****D . Refitting the input gearbox and shimming the layshaft**

22. Refit the input gearbox (see Section 5 B01).
23. Shim the layshaft (see Fig. 4) to obtain a play of :  
**J2 = 0.04 to 0.12 mm** (Fig. 5)
24. Install the locally manufactured tool (see Section E) in the layshaft (Fig. 6).
25. Compress the spring moderately by tightening the nut on the tool in order to bed the cones correctly in the cups.
26. Rotate the shaft through a few turns.
27. Using a depth gauge, measure the dimension **X** between face **A** of the cup (**52**) and face **B** on the housing (see Fig. 5).
28. Measure the thickness **Y** of the deflector (**50**).
29. Calculate the difference between **X** and **Y**.
30. Determine the shim thickness required to obtain a play of **J2**.
31. Remove the compression tool.
32. Position the shims (**51**) selected in procedure 30.
33. Fit the deflector in the housing.
34. Adjust the reversing selector (see Section 5 B04).  
Refit the selector cover (see Section 5 C01 or 5C02 according to the version).  
**Note : Do not forget to fit the bolt (1) on the housing (Fig. 5), Section 5 C01.**
35. Recouple the gearbox with the engine (see Section 2 A01).
36. Recouple the tractor between the gearbox and the rear axle (see Section 2 B01).
37. Check:
  - the systems for leaks
  - the operation of the electrical circuits.
38. Carry out a road test on all the controls.
39. Check the unions and mating faces for leaks (selector cover, and gearbox on rear axle).

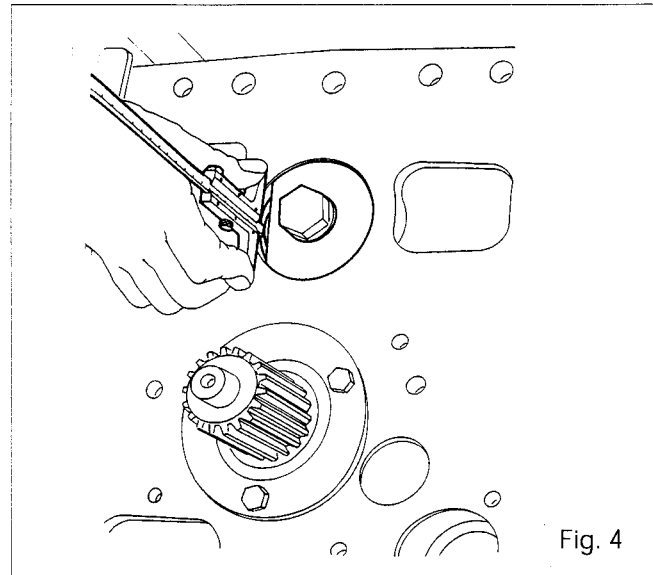

Fig. 4

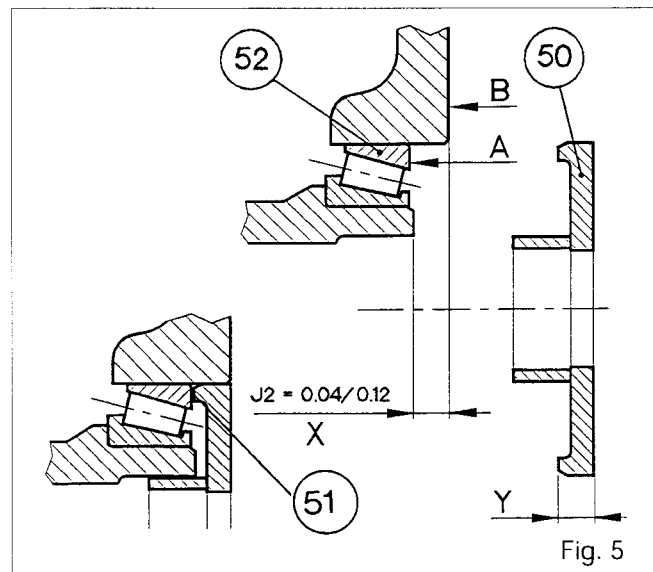

Fig. 5



# Heavy Duty gearbox - Intermediate shaft

5F02.5

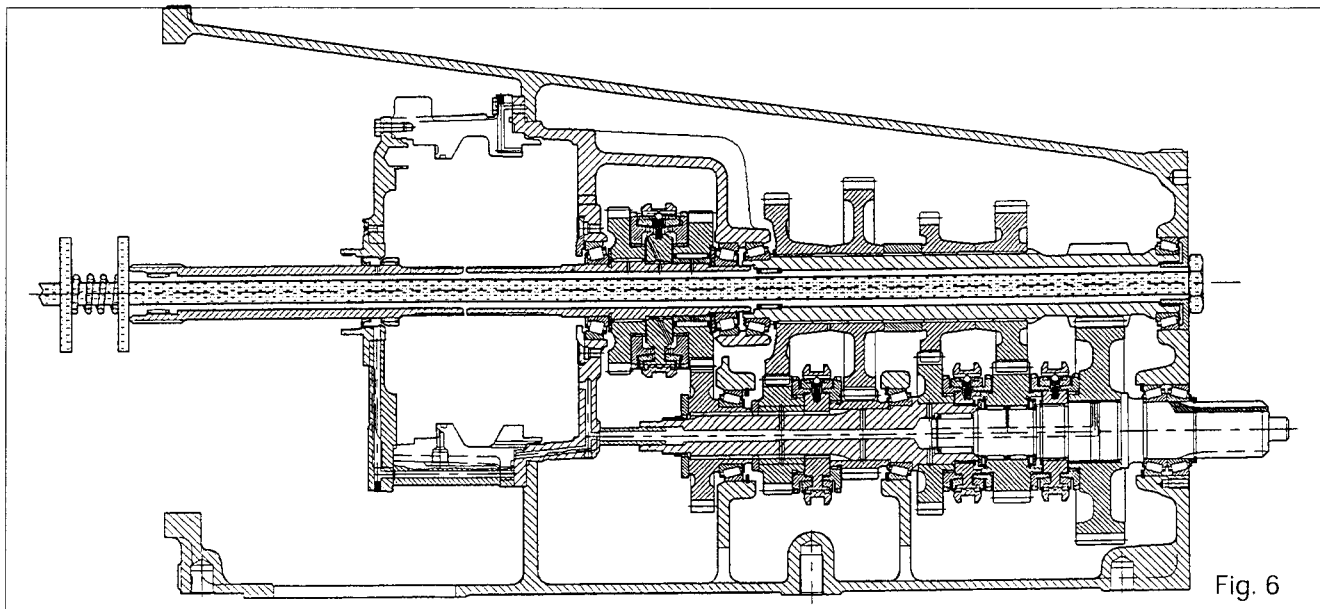

Fig. 6

## E . Service tool

Layshaft holding tool, to be manufactured locally.

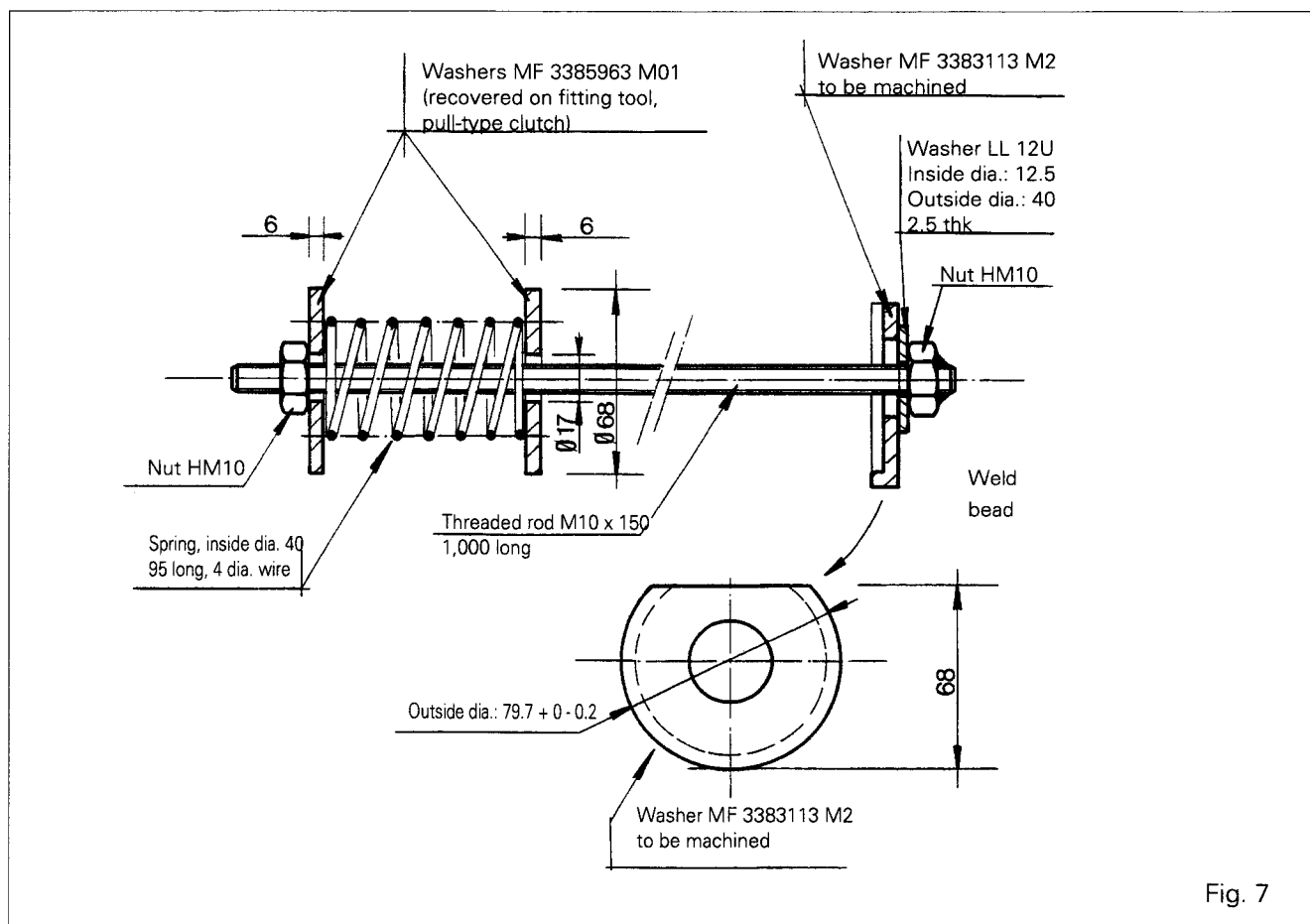

Fig. 7





5 G01 Mainshaft

CONTENTS

-	<b>General</b> _____	2
A.	<b>Preliminary operations</b> _____	2
B.	<b>Disassembling and reassembling the mainshaft</b> _____	4
C.	<b>Final operations</b> _____	6
D.	<b>Service tools</b> _____	7



5G01.2

## 6100 SERIES TRACTORS

**Gearbox - Mainshaft****General**

The mainshaft (69) is fitted on the two taper roller bearings (1) (2) and (16) (17) which are supported by the two lower bearings of the main gearbox. The front end houses the input gear (67).

Between the two lower bearings, it supports the 1st (7) and 2nd (14) driving gears which run free and the 1st and 2nd gear synchromesh assembly (11) whose hub is splined onto it.

At the rear end, it supports the 3rd and 4th gear synchromesh assembly (23).

The bore in the rear end carries a needle-roller bearing which supports the front end of the output shaft. The moving parts are lubricated by a central oilway and radially-drilled holes. The taper roller bearings are preloaded by means of a shim (4) and shim adjusters (3) located behind the bearing cup (2).

**Service tools**

See part D.

**A. Preliminary operations**

The gearbox must be removed in order to dismantle the mainshaft.

1. Split the tractor between the gearbox and the rear axle, as per section 2 B01.
2. Separate the gearbox from the engine, see section 2 A01.

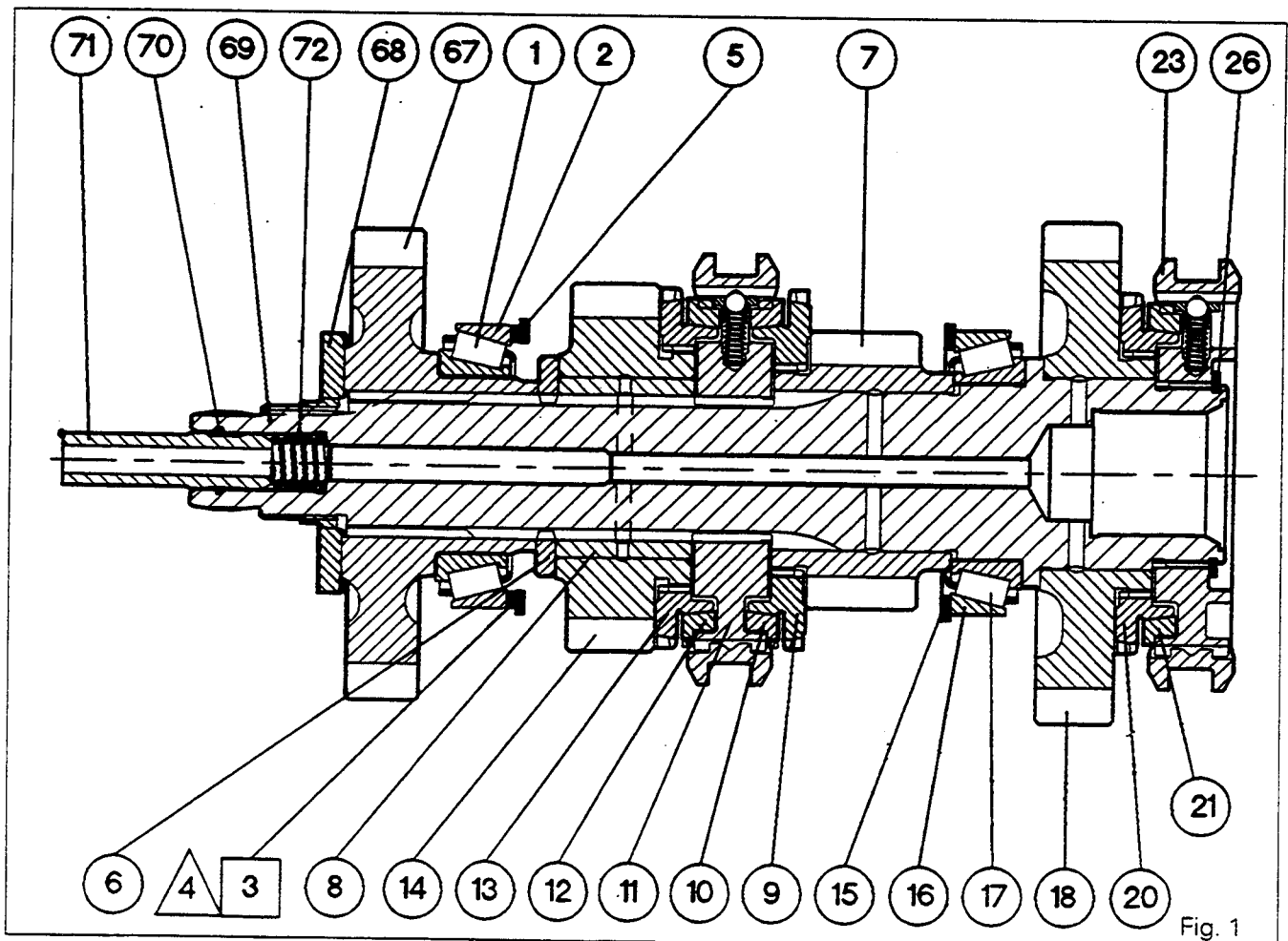



**Gearbox - Mainshaft**

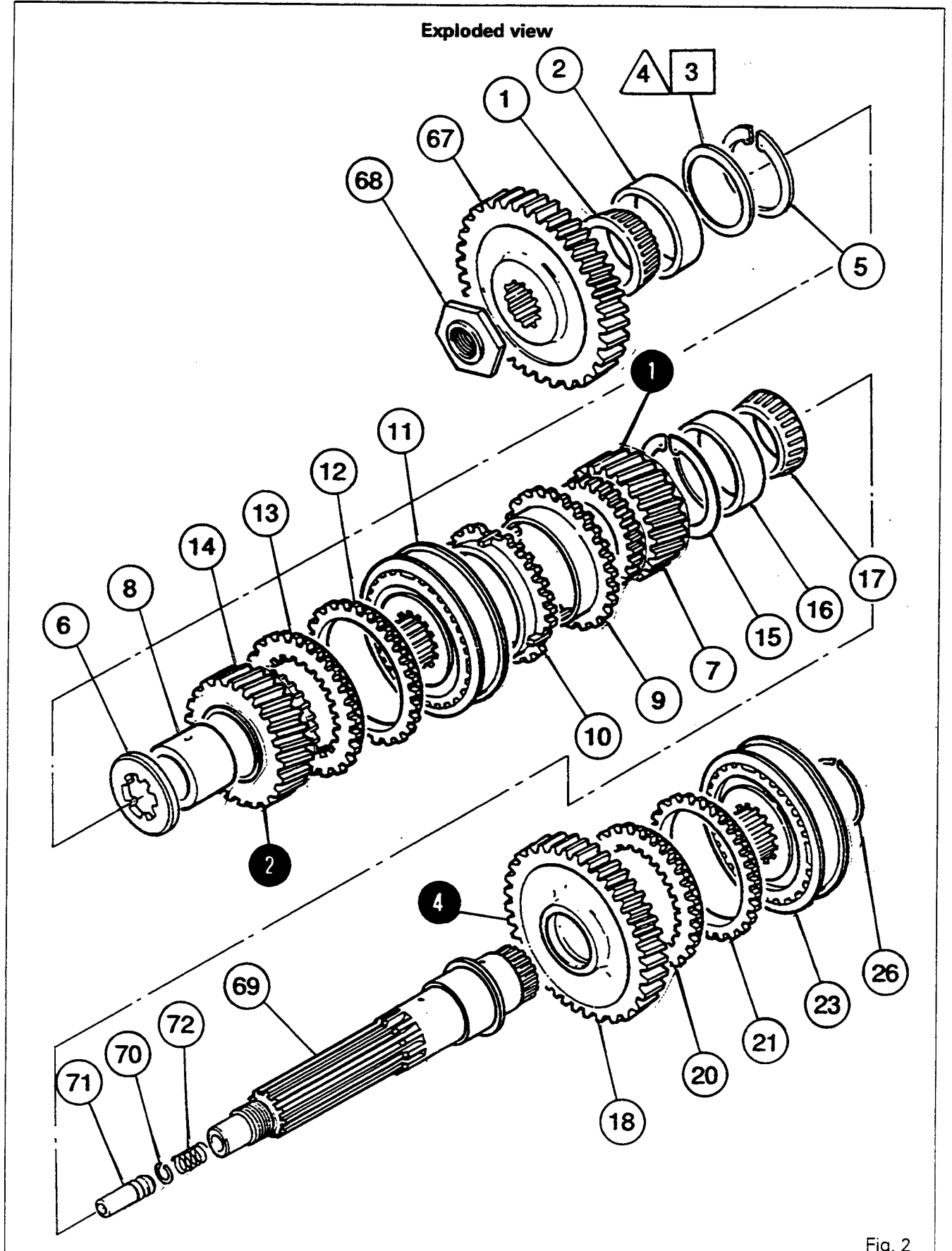
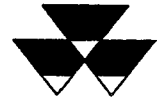

Fig. 2





5G01.4

## Gearbox - Mainshaft

3. Remove the selector cover, see section 5 C01 or 5 C02 in according to version.  
Remove the bolts (1) (Fig. 9) as per section 5 C01.
4. Remove the guide rail and the forks, see section 5 D01.
5. Remove the input gearbox assembly, see section 5 B01.
6. Remove the layshaft, see section 5 F01.
7. Remove the output shaft, see section 5 E01.

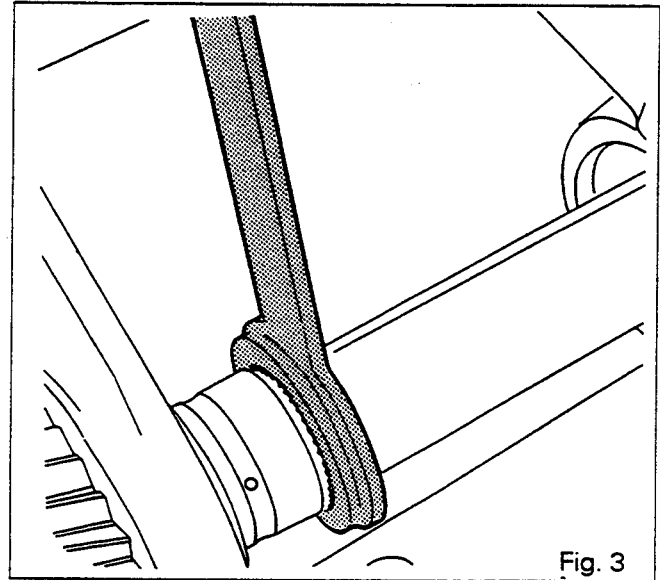

Fig. 3

### B. Disassembling and reassembling the mainshaft

#### Disassembly

8. Remove the circlip (26).
9. Remove the 3rd and 4th gear synchromesh (23).  
Mark the direction of fitting.
10. Remove the synchromesh ring (21).
11. Remove the synchromesh cone (20) and the gear (18).  
**Note : Keep the synchromesh ring and cone as a pair for possible re-use.**
12. Position the retaining tool MF 458 (Fig. 3) and the locally manufactured holding sleeve for the mainshaft (69) (Fig. 4). (See part D).
13. Remove the oil feed pipe (71) and spring (72).
14. Unlock the nut (68) and loosen it using socket 3378010 M1 (Fig. 5).
15. Remove the input gear (67) and cone (1).
16. Remove the washer (6).
17. Remove tool MF 458 and the sleeve (Fig. 3 and 4).
18. Withdraw the shaft rearwards from the housing, holding the 1st and 2nd gear train in place.
19. From inside the housing and in the following order, remove: the 2nd gear (14) with bush (8), cone (13), 2nd gear synchromesh ring (12), 1st and 2nd synchromesh (11), cone (9), 1st gear synchromesh ring (10), the cone (9) and the 1st gear (7).
20. Withdraw the cups (16) and (2).  
**Note : Keep the cups and cones in pairs for possible re-use.**

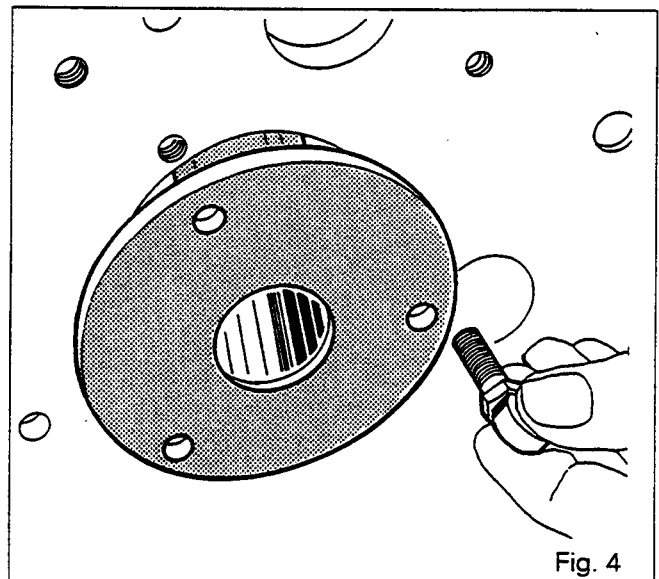

Fig. 4

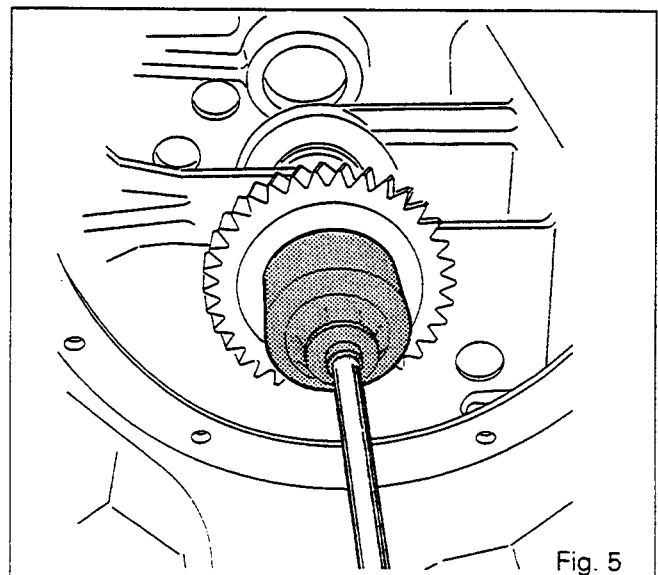

Fig. 5



## Gearbox - Mainshaft

5G01.5

21. Remove the adjusting shims [3], the shim /4\ and circlips (15) and (5).

**Note : Measure the thickness of the adjusting shims for use on the mainshaft during reassembly operations.**

22. Remove the cone (17) and retaining ring (70).

### Reassembly

23. Clean the housing and the mating faces.
24. Using a jet of compressed air, check that all the oilways in the gearbox and the shaft are free of obstructions. Clean and check the parts, and replace any that are faulty.
25. Lubricate the cones, the cups, the bearing bores and the bush.
26. Using a press, fit the bearing cone (17) onto the shaft (69).
27. Fit the retaining ring (70). Fit the circlips (5) and (15).
28. Position the shim /4\ against circlip (5) (Fig. 6).
29. Reduce the thickness of the shims [3] whose measurements were noted during disassembly by approximately 0.3 mm so as to obtain an end play of between 0.10 and 0.15 maximum so as to obtain an exact fit.
30. Install the shims [3] and the cups (2) and (16).
31. In the housing and in the following order, assemble the 1st gear (7), cone (9), the 1st gear synchromesh ring (10), the 1st and 2nd speed synchromesh (11), the 2nd gear synchromesh ring (12), cone (13) and the 2nd gear (14) with bush (8).
32. Insert the shaft through the rear of the housing, while supporting the synchromesh gear assembly (Fig. 7).
- Note : Check that the bush (8) is correctly positioned in the gear (14).**
33. Fit the retaining tool MF 458 and the locally made holding sleeve (Fig. 3 and 4).
34. Fit the washer (6).
35. Fit the cone (1) onto the gear (67).
36. Fit the gear (67) onto the shaft (69).
37. Fit the nut (68) using the special socket 3378010M1. Tighten to a torque of 130 - 170 Nm (Fig. 8).
38. Shim the shaft. Remove tool MF 458 and the sleeve (Fig. 3 and 4).

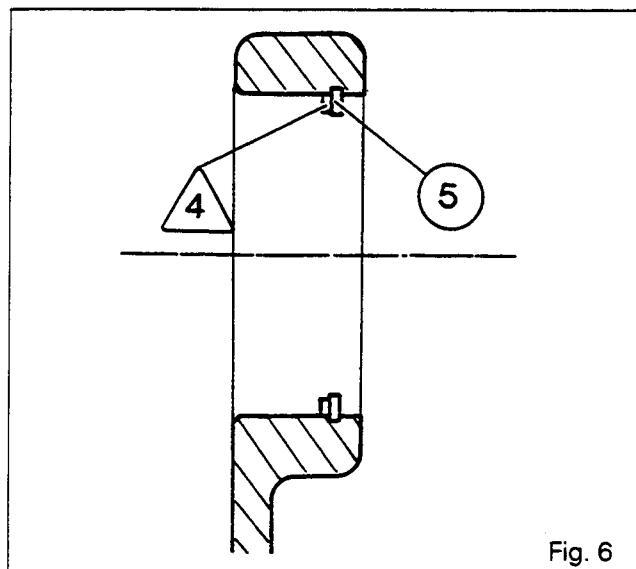

Fig. 6

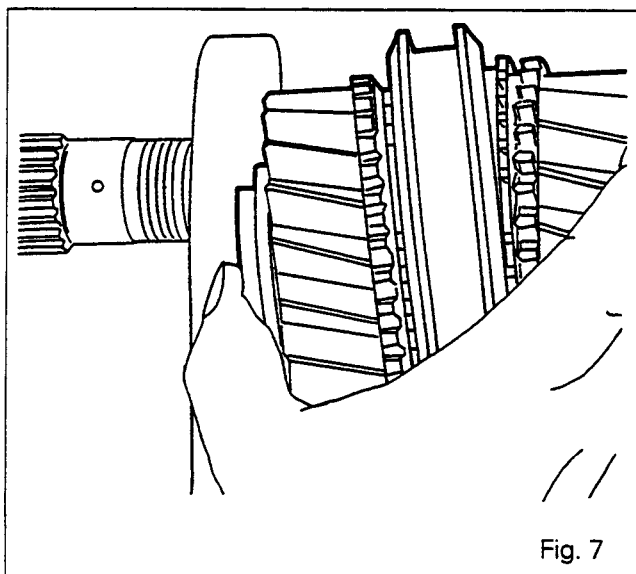

Fig. 7

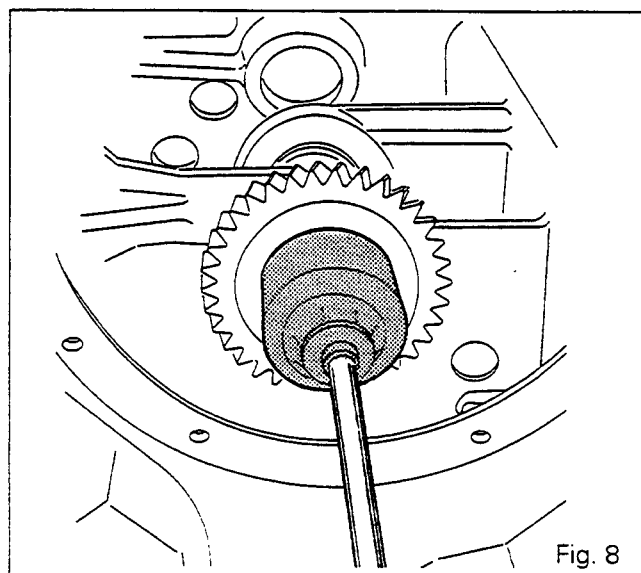

Fig. 8



5G01.6

## 6100 SERIES TRACTORS

**Gearbox - Mainshaft**

39. Position the pointer of a dial gauge at the end of the shaft (Fig. 9).
40. From the front of the housing, pull on the shaft and turn it 1st to the right and then to the left, so that the cones are properly seated in the cups.
41. Set the dial gauge to zero.
42. Repeat procedure 40, while pushing on the shaft.
43. According to the play measured, select the shim thickness required to obtain a preload of :  
**P1 = 0.14 to 0.20**
44. Fit the retaining tool MF 458 and the locally manufactured holding sleeve (Fig. 3 and 4).
45. Unlock nut (68). Remove the gear (67).
46. Take out the cup (2).
47. Fit the adjusting shims [3] selected during procedure 43.  
**Note : The shim /4/ must be positioned on the same side as the circlip (5) (Fig. 6).**
48. Reinstall the cup and the gear.
49. Degrease the thread on the shaft with a solvent.
50. Lightly coat the nut (68) with Loctite 270 and then tighten to a torque of 130 - 170 Nm.
51. Lock the nut, bending the collar into the groove with a suitable drift punch.
52. Insert the spring (72) and the oil feed pipe (71) into the shaft.
53. Remove tool MF 458 and the holding sleeve.
54. Fit the gear (18) and the synchromesh cone (20), as well as the ring (21) and the 3rd and 4th synchromesh (23).
55. Fit the circlip (26).  
Note: Check that the synchromesh is facing the right way.
56. Check the following by hand:
  - a) the end play on gears,
  - b) the rotation of the shaft and gear train.
57. Check that the 1st and 2nd gear synchromesh functions correctly.

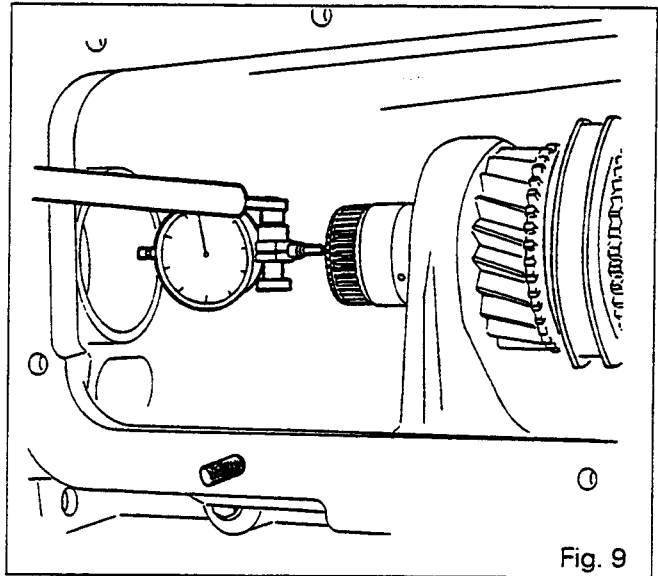

62. Reassemble the forks and the guide rail/see section 5 D01.
63. Adjust the reversing selector, see section 5 B04.
64. Refit the selector cover, see section 5 C01 or 5 C02 in according to version.  
**Note: Do not forget to install the bolt (1) on the housing (see Fig. 9, section 5 C01).**
65. Recouple the gearbox with the engine, see section 2 A01.
66. Reconnect the gearbox and the rear axle (Section 2 B01).
67. Check the operation of the electrical circuits.
68. Carry out a road test on the controls.
69. Check the unions and mating faces for leaks (selector cover, and gearbox on rear axle).

## C. Final operations

58. Refit and shim the output shaft, see section 5 E01.
59. Refit the layshaft, see section 5 F01.
60. Refit the input gearbox assembly, see section 5 B01.
61. Shim the layshaft, see section 5 F01..



# Gearbox - Mainshaft

## D. Service tools

### 1. Tools available from the MF network

Socket for mainshaft nut

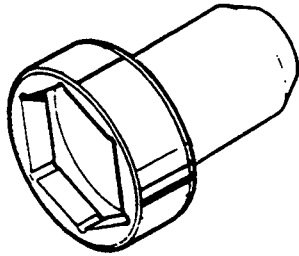

3378010M1

Mainshaft retaining tool

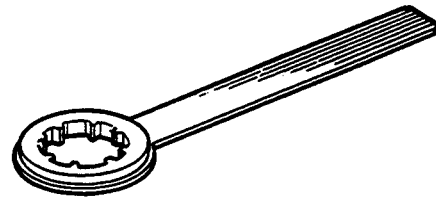

MF 458

### 2. Locally manufactured tool

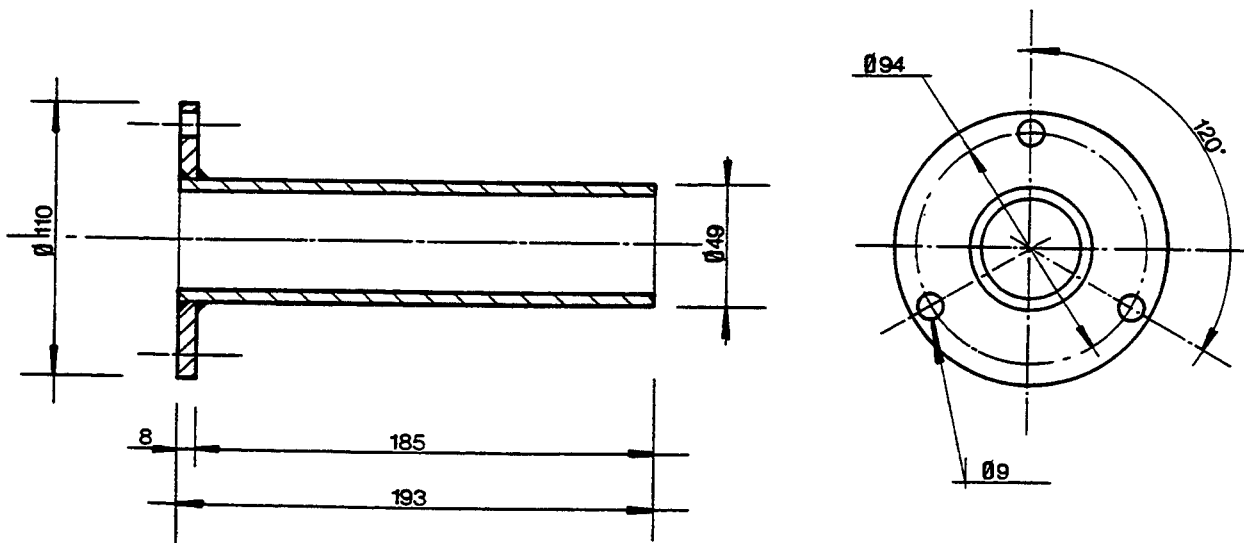

Mainshaft holding tool





---

6100 SERIES TRACTORS

---



## **Heavy Duty gearbox - Mainshaft**

5G02.1

### *5 G02 Mainshaft*

#### CONTENTS

-	<b>General</b> _____	<b>2</b>
A.	<b>Preliminary operations</b> _____	<b>4</b>
B.	<b>Disassembling and reassembling the mainshaft</b> _____	<b>4</b>
C.	<b>Final operations</b> _____	<b>6</b>
D.	<b>Service tools</b> _____	<b>7</b>



5G02.2

## 6100 SERIES TRACTORS

**Heavy Duty gearbox - Mainshaft****General**

The design of the mainshaft for the heavy duty gearbox is identical to that of mainshaft for the standard gearbox.

The following differences should be noted, however:

- The mainshaft **(69)** is fitted on two taper roller bearings **(1)** and **(17)** with shouldered cups **(2)** and **(16)**.
- Similarly to the standard mainshaft, preloading of the taper roller bearing is obtained by means of shims **(3)** located between splined washers **(6)** fitted against the input gear **(67)** and bush **(8)**.
- A washer **(77)** with flats acts as a stop for the 1st driving gear **(7)**.
- The length of the thread to the front of the shaft has been modified to allow the fitting of a thicker nut **(68)**.
- To the rear end, the shaft is reinforced and the bore for the 4th gear **(18)** is larger.
- The double-cone, 3rd - 4th gear synchromesh hub **(23)** is held onto the mainshaft by means of 14 splines.

**List of parts**

- (1)** Bearing cone
- (2)** Bearing cup
- (3)** Shim(s)
- (6)** Splined washers
- (7)** 1st driving gear
- (8)** Bush
- (11)** Double cone 1st - 2nd gear synchromesh
- (14)** 2nd driving gear
- (16)** Bearing cone
- (17)** Bearing cup
- (18)** 4th driving gear
- (23)** Double cone 3rd - 4th gear synchromesh
- (26)** Circlip
- (67)** Input gear
- (68)** Nut
- (69)** Mainshaft
- (70)** Retaining ring
- (71)** Oil feed pipe
- (72)** Spring
- (77)** Washer with flats
- (78)** Tab washer

**Service tools**

See Part D.

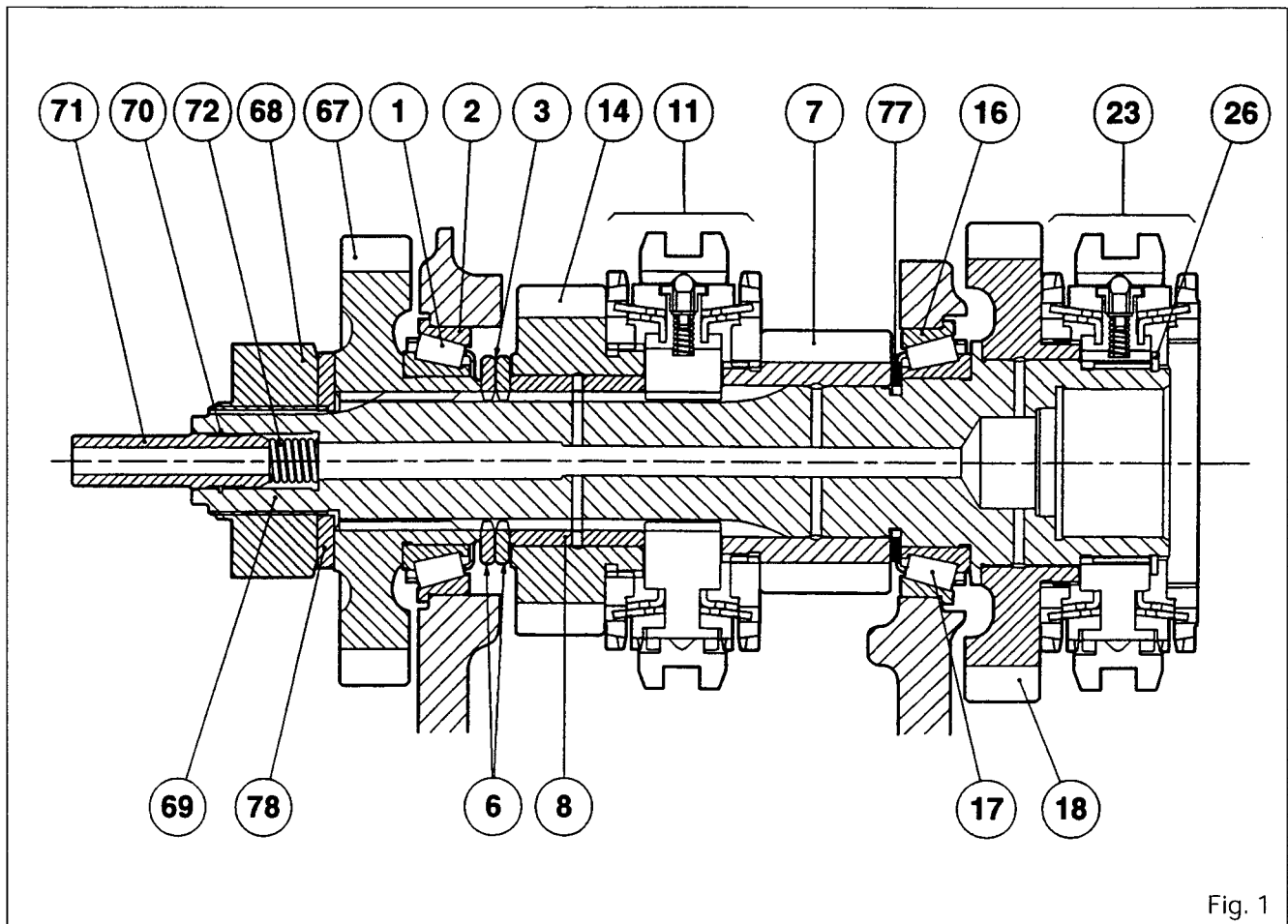

Fig. 1



# Heavy Duty gearbox - Mainshaft

5G02.3

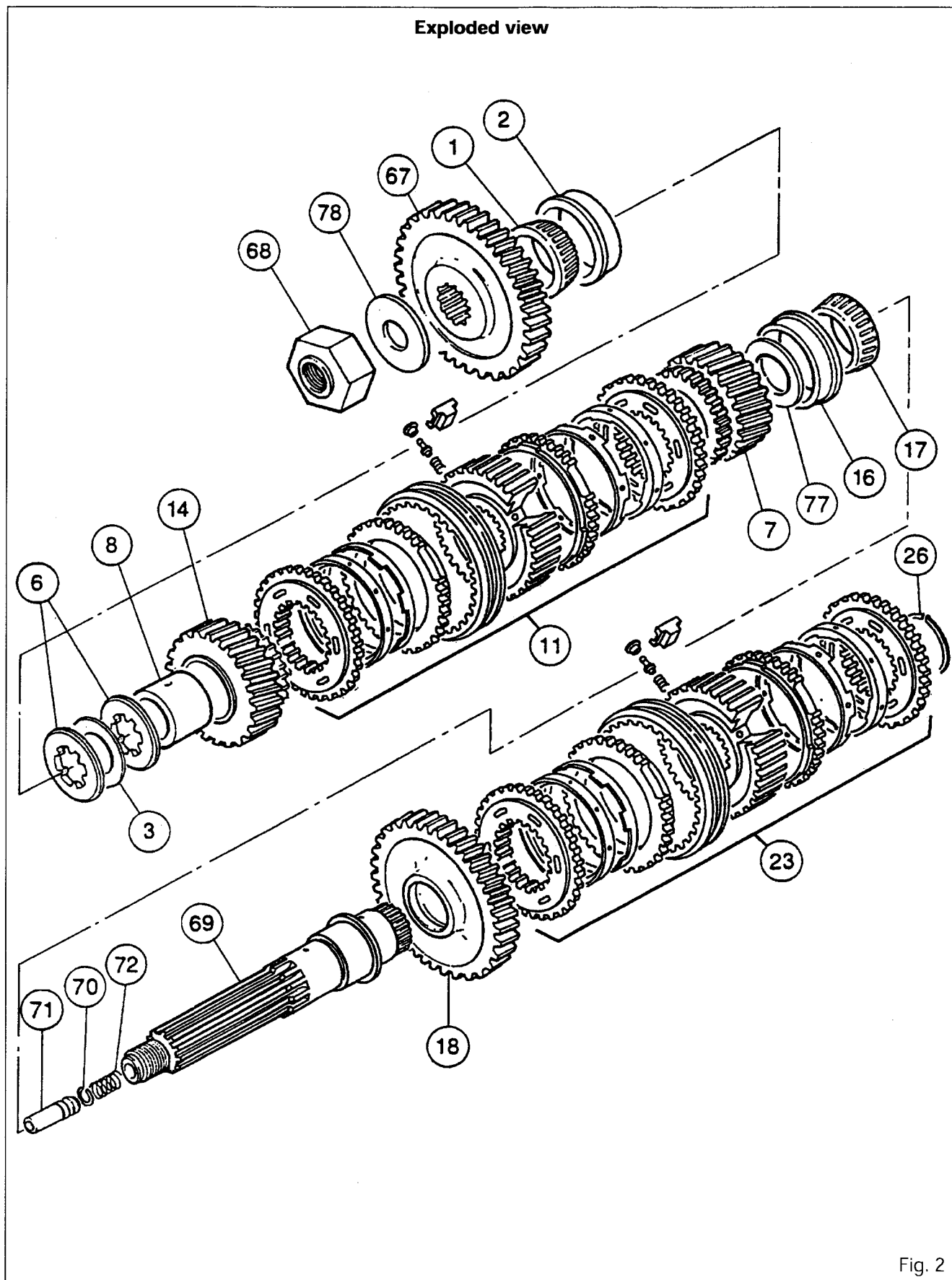

Fig. 2





5G02.4

## Heavy Duty gearbox - Mainshaft

### A . Preliminary operations

The gearbox must be removed in order to disassemble the mainshaft.

1. Split the tractor between the gearbox and the rear axle (as per Section 2B01).
2. Separate the gearbox from the engine (as per Section 2A01).
3. Remove the selector cover. (as per Section 5C01 or 5C02 according to the version).
4. Remove the input gearbox assembly (as per Section 5B01).
5. Remove the layshaft (as per Section 5F02).
6. Remove the forks and the selector rail (as per Section 5D02). Remove the output shaft (as per Section 5E02).

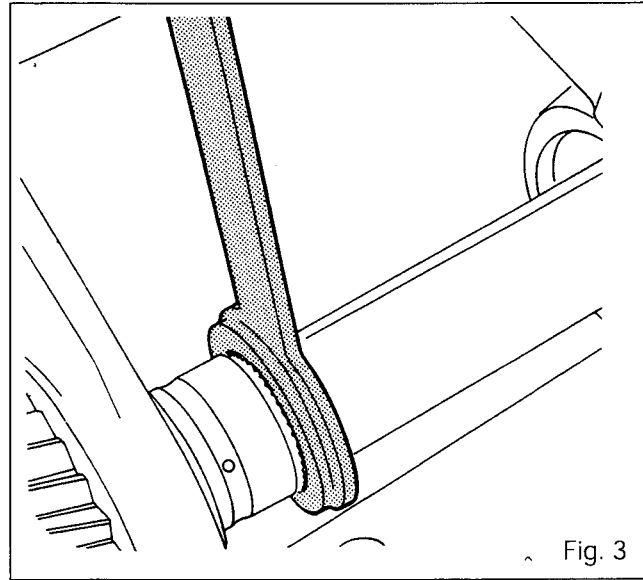

Fig. 3

### B . Disassembling and reassembling the mainshaft

#### Disassembly

**Note: If work is to be carried out on the input gear (67) only, the 1st - 2nd synchromesh and gear assembly must be held in place with a screwdriver in order to avoid moving the washer with flats (77).**

7. Remove the circlip (26).
  8. Remove the 3rd and 4th gear synchromesh (23). Mark the direction of fitting.
  9. Position the retaining tool 3378082M1 (Fig. 3) and the locally manufactured holding sleeve for the mainshaft (69) (Fig. 4). (See part D).
  10. Remove the oil feed pipe (71) and spring (72).
  11. Unlock the nut (68) and loosen it using socket 3378010M1 (Fig. 5).
  12. Remove the input gear (67) and cone (1).
  13. Remove the washers (6) and the shims (3).
  14. Remove the tool (see above) and the sleeve (Figures 3 and 4).
  15. Withdraw the shaft rearwards from the housing, holding the 1st and 2nd gear train in place.
  16. Remove the 1st - 2nd gear assembly and synchromesh (11) with bush (8). Withdraw the cups (16) and (2).
- Note : Pair up the cups and cones if they are to be reused.**
17. If necessary, remove the washer with flats (77), extract cone (1) (17) and remove the retaining ring (70).

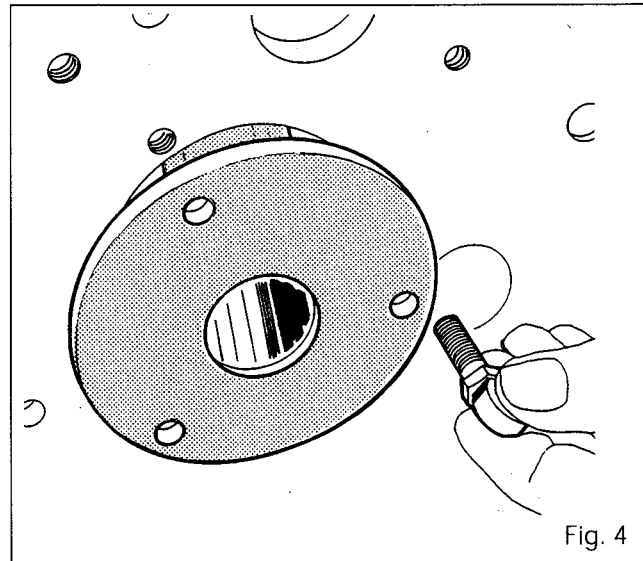

Fig. 4

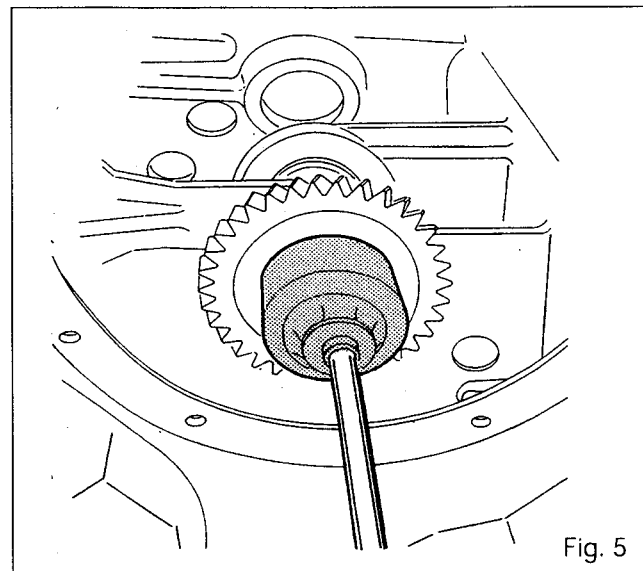

Fig. 5



## Heavy Duty gearbox - Mainshaft

5G02.5

### Reassembly

18. Clean the housing and the mating faces.
19. Using a jet of compressed air, check that all the oilways in the gearbox and the shaft are free of obstructions. Clean and check the parts, and replace any that are faulty.
20. Lubricate the cones, the cups, the bearing bores and the bush.
21. Using a press, fit the bearing cone (17) onto the shaft (69), (if it was removed).
22. Fit the retaining ring (70).
23. Increase the thickness of the shims (3) that were removed during disassembly so as to obtain an end play of between 0.10 and 0.15 maximum, in order to obtain an exact fit.
24. Fit the cups (2) and (16).
25. Reinstall the 1st - 2nd gears and synchromesh (11) with the bush (8).
26. Insert the shaft through the rear of the housing, while supporting the synchromesh/gear assembly (Fig. 6) and ensuring that the bush (8) is correctly positioned in the gear (14).
27. Fit the retaining tool and the locally manufactured holding sleeve (Figures 3 and 4).
28. Fit the shims (3), increased in thickness in procedure 23, between the washers (6).
29. Fit the cone (1) onto the gear (67), (if it was removed).
30. Fit the gear (67) onto the shaft (69).
31. Fit the nut (68) using socket 3378010M1. Tighten to a torque of between 130 and 170 Nm (Fig. 5).
32. Shim the shaft. Remove tool and the sleeve (Figures 3 and 4).
33. Position the tip of a dial gauge on the end of the shaft (Fig. 7).
34. From the front of the housing, pull on the shaft and turn it 1st to the right and then to the left, so that the cones are properly seated in the cups.
35. Set the dial gauge to zero.
36. Repeat procedure 34, while pushing on the shaft.
37. According to the play measured, select the shim thickness required to obtain a preload of:  
**P1 = 0.14 to 0.20**
38. Fit the retaining tool and the holding sleeve (Figures 3 and 4).
39. Unlock nut (68). Remove the gear (67).
40. Fit the shims (3) selected during procedure 37 between the two washers (6).
41. Reinstall the gear.
42. Degrease the thread on the shaft with a solvent.

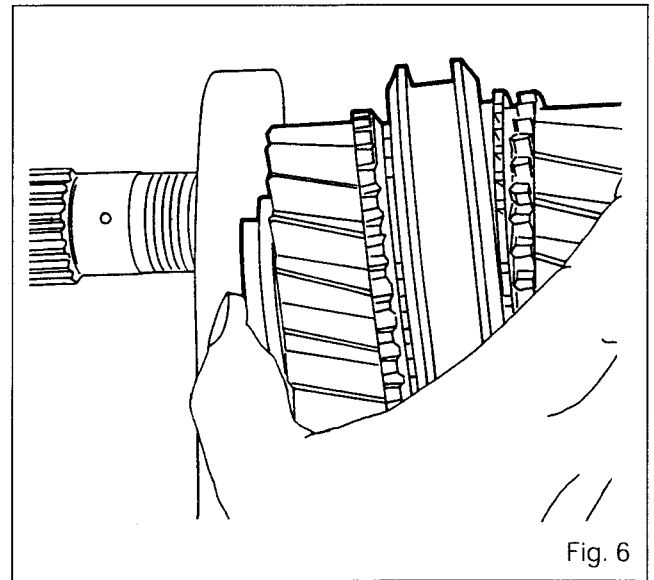

Fig. 6

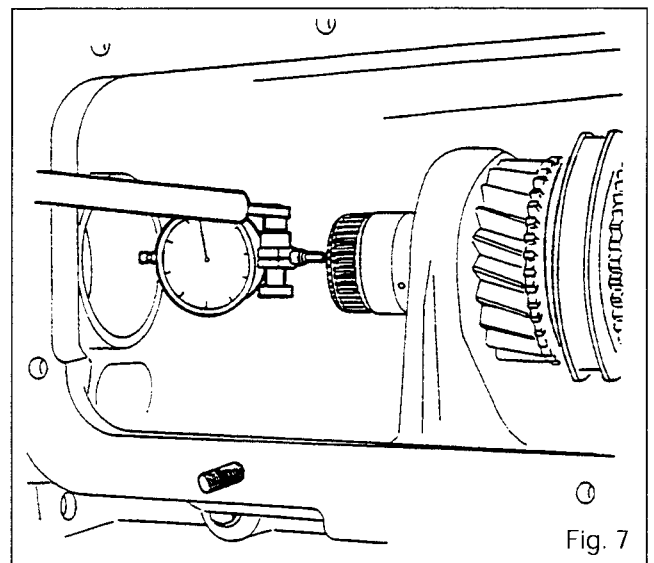

Fig. 7



5G02.6

## Heavy Duty gearbox - Mainshaft

43. Lightly coat the nut **(68)** with Loctite 270 and then tighten to a torque of between 130 and 170 Nm.
44. Lock the nut by bending the collar into the groove with a suitable drift punch.
45. Insert the spring **(72)** and the oil feed pipe **(71)** into the shaft.
46. Remove the tool and the holding sleeve.
47. Fit the gear **(18)** and 3rd and 4th gear synchromesh **(23)** with the oilways pointing towards the 4th gear **(18)**.
48. Fit a new circlip **(26)**.  
**Note: Open the circlip as little as possible. After fitting, check that it has not been deformed.**
49. Check the following by hand:
  - a) the end play on gears,
  - b) the rotation of the shaft and gear train.
50. Check that the 1st and 2nd gear synchromesh functions correctly.

### C . Final operations

51. Refit and shim the output shaft (as per Section 5E02).
52. Refit the layshaft (as per Section 5F02).
53. Refit the input gearbox assembly (as per Section 5B01).
54. Shim the layshaft (as per Section 5F02).
55. Reassemble the forks and the selector rail (as per Section 5D01).
56. Adjust the reversing selector (as per Section 5B04).
57. Refit the selector cover (as per Section 5C01 or 5C02 according to the version).  
**Note: Do not forget to install the bolt (1) on the housing (see Fig. 9, Section 5C01).**
58. Recouple the gearbox with the engine (as per Section 2A01).
59. Recouple the gearbox and the rear axle (as per Section 2B01).
60. Check the operation of the electrical circuits.
61. Carry out a road test on the controls.
62. Check for leaks on the unions and mating faces (selector cover, and gearbox on rear axle).



# Heavy Duty gearbox - Mainshaft

5G02.7

## D . Service tools

### 1. Tools available from the MF network

Socket for nut

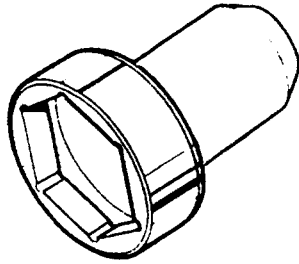

3378010M1

Mainshaft retaining tool

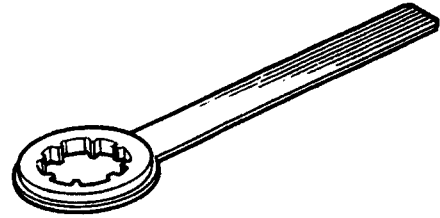

3378082M1

### 2. Locally manufactured tool

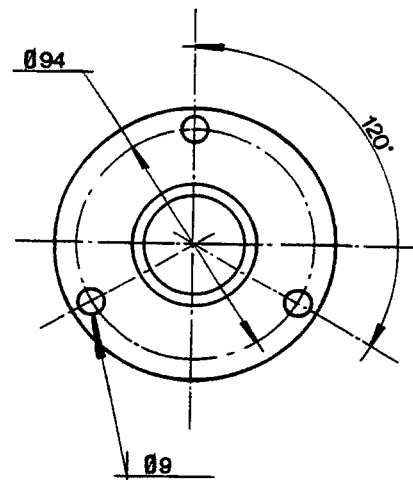
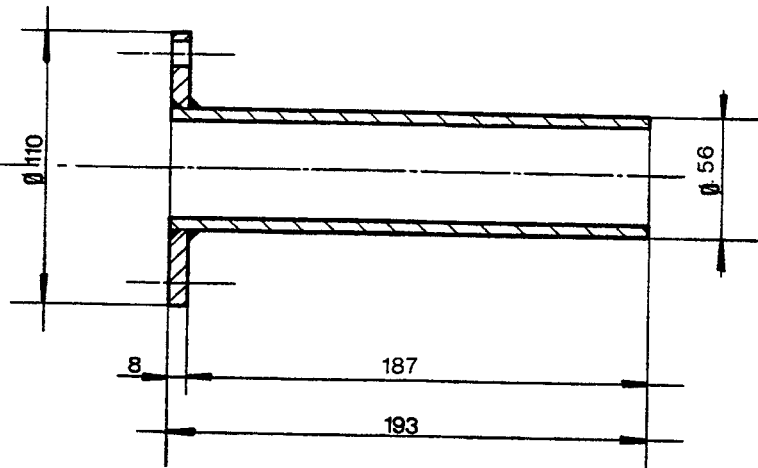

Holding tool





**Gearbox - Creeper gears**

*5 H01 Creeper gears*

CONTENTS

- **General** \_\_\_\_\_ 2
- **Operation** \_\_\_\_\_ 2
- A. **Removing creeper gearbox and ring gear** \_\_\_\_\_ 3
- B. **Disassembling planetary carrier** \_\_\_\_\_ 5
- C. **Reassembling planetary carrier and installing gearbox** \_\_\_\_ 5
- D. **Final procedures** \_\_\_\_\_ 5
- E. **Adjusting control mechanism** \_\_\_\_\_ 6
- F. **Circuit diagram** \_\_\_\_\_ 7



5H01.2

## ***Gearbox - Creeper gears***

### **General**

The creeper gear reduction gearbox consists of an epicyclic gear train comprising of a planetary carrier and ring gear assembly mounted at the rear of the main gearbox. It is operated from a lever located on the console, inside the cab. The lever is connected by a cable to an arm fitted on the right front side of centre housing. The arm shifts the fork which in turn controls the coupling sleeve.

The creeper gears should only be selected if the main gearbox is in the Lo range.

### **Operation**

Coupling sleeve **(8)** is splined to connecting shaft **(21)**. If lever A is moved towards the creeper gear position (Fig. 3), coupling **(8)** is shifted towards the rear and its external teeth engage with the planetary carrier **(1)**. Connecting shaft **(21)** speed is then 1/4 of output shaft speed.

In normal gears, output shaft is coupled with connecting shaft **(21)** when sleeve **(8)** is moved forward, thus providing direct transmission.

When creeper range is selected (snail light ON) and Hi (hare) light blinks, the operator is informed that the gearbox is on the Hare position. He then **must** shift to Lo position.

The electrical signal indicating that creeper speed range is selected is transmitted from the control cabin mounted **C** switch (Fig. 3).



## Gearbox - Creeper gears

### A . Removing creeper gearbox and ring gear

1. Remove RH hydraulic cover. Carry out procedures 1 to 14, section 9 101.
2. Disassemble PTO assembly.

#### a) Two-speed PTO

Remove third point bracket, leading gear and connecting shaft, then carry out procedures 1 to 7, section 7 A01.

Remove PTO clutch and carry out procedure 3, section 7 E01.

#### b) Four-speed Economy PTO

Remove third point bracket, leading gear and connecting shaft, then carry out procedures 56 to 74, section 7 A01.

Remove PTO clutch and carry out procedure 14, section 7 E01.

3. Remove coupling sleeve assembly, connecting shaft, coupler and fork, then carry out procedures 4 to 16, Section 5 D01.A.

### Removing creeper gearbox and ring gear

4. Take out bolts (5) and spring washers (4).
5. Remove front disc (3).
6. Withdraw planetary carrier assembly (17) and thrust washers (2) and (18).
7. Remove ring gear (19).

**N.B. : Leave locating pins (20) inside ring gear.**

8. Remove backing disk (15) without pulling output shaft.

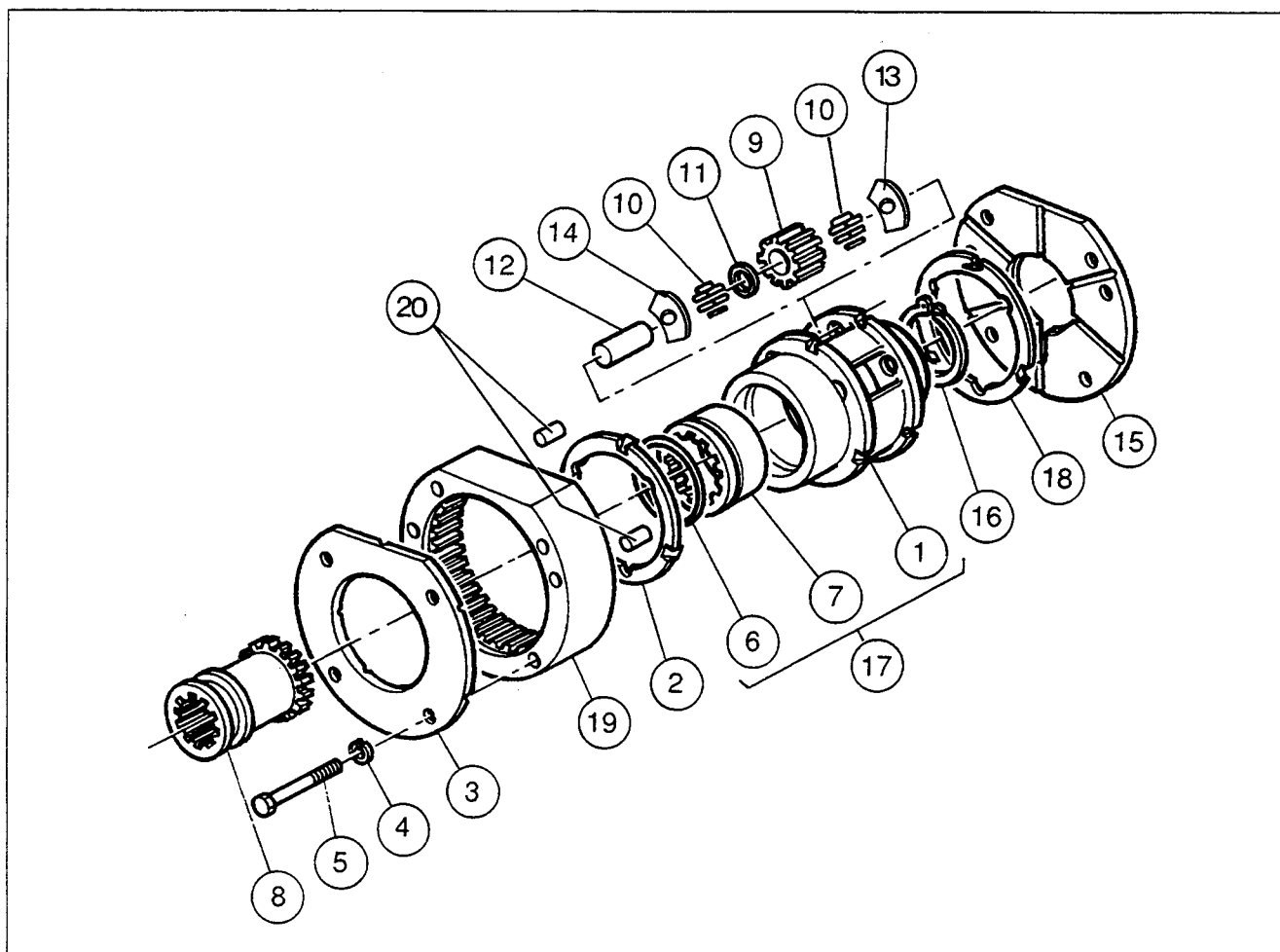





6100 SERIES TRACTORS



5H01.4

Gearbox - Creeper gears

General arrangement drawing

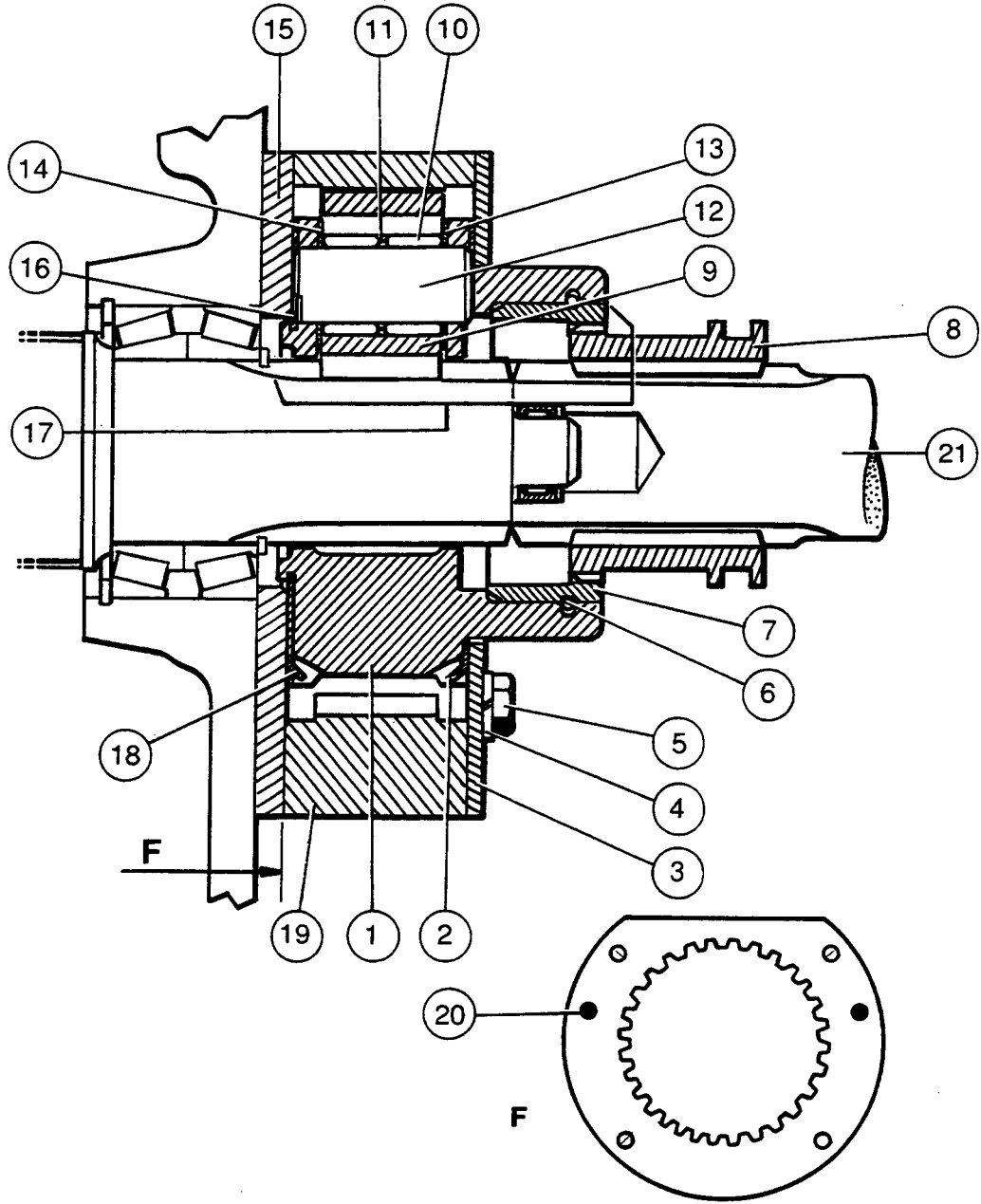

List of parts

- (1) Planetary carrier
- (2) Thrust washer
- (3) Front disc
- (4) Spring washer
- (5) Bolt
- (6) Spring ring
- (7) Internally toothed bush
- (8) Coupling sleeve
- (9) Planetary gears
- (10) Needle rollers
- (11) Spacer
- (12) Pin
- (13) Sector plate
- (14) Sector plate
- (15) Backing disk
- (16) Circlip
- (17) Planetary carrier assembly
- (18) Thrust washer
- (19) Ring gear
- (20) Locating pin
- (21) Connecting shaft

Fig. 1



## Gearbox - Creeper gears

### B . Disassembling planetary carrier

9. Remove circlip (18).
  10. Drive out pins (12).
  11. Remove sector plates (13) and (14).
  12. Remove planetary gears (9).
- N.B.: Remove planetary carrier (1) if internally toothed bush (7) is damaged, even slightly.**

### C . Reassembling planetary carrier and installing gearbox

13. Check and clean parts. Replace any faulty part.
14. Refit planetary gears (9). Apply miscible grease («Amber Technical» or equivalent) to needle rollers(10) when mounting.
15. Refit sector plates (13) and (14).
16. Refit pins (12), making sure they are oriented properly to allow for circlip (16) mounting.
17. Mount circlip (16). Move each planetary gear by hand to check end play and free rotation.
18. Install creeper gearbox (Fig. 2). Set backing disk (15) and ring gear (19) on casing.
19. Apply miscible grease on thrust washers (2) and (18) and set them on planetary carrier (4).
20. Slide planetary carrier over output shaft.
21. Set backing disk (3). Torque screws (5) to 34 - 52 Nm.

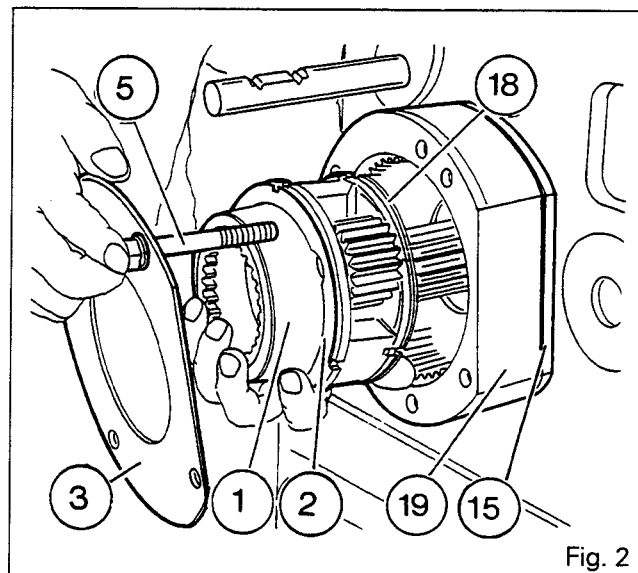

Fig. 2

### D . Final Procedures

22. Refit fork, coupling sleeve, connecting shaft and coupler and carry out procedures 22 to 31, section 5 D01.A.
23. Reassemble PTO assembly.
  - a) **Two-speed PTO**  
Refit PTO assembly and carry out procedures 5 to 7, section 7 E01.  
Refit connecting shaft, leading gear and third point bracket, then carry out procedures 8 to 18, section 7 A01.
  - b) **Four-speed PTO**  
Refit PTO assembly and carry out procedures 16 to 18, section 7 E01.  
Refit connecting shaft, leading gear and third point bracket, then carry out procedures 75 to 94, section 7 A01.
  24. Refit right hydraulic cover and carry out procedures 15 to 33, section 9 101.
  25. Test drive and check creeper gears.
  26. Check PTO and PTO brake operation.



5H01.6

## 6100 SERIES TRACTORS

**Gearbox - Creeper gears****E. Adjusting control mechanism (Fig. 3 and 4)**

27. Move control lever **A** to "Creeper" position.
28. Screw clevis **(1)** up to end of cable **(6)** threaded portion.
29. Attach clevis **(1)** to lever **A** with pin **(7)** and tighten nut **(2)**.
30. Fully tighten nut **(3)** on cable ferrule **(5)**
31. Mount cable ferrule and spring washer on bracket. Tighten nut **(4)**.  
**N.B.: Check that cables are not under stress;**
32. Move arm **B** to «creeper speed» position (Fig. 4) (gearbox teeth **(8)** engaged backwards (Fig. 1). Fork should be locked.
33. Screw clevis **(9)** up to end of cable **(6)** threaded portion (Fig. 4).
34. Mount clevis **(9)** on arm **B** with pin **(10)** and tighten nut **(11)** (Fig. 4).
35. Adjust stopper **(12)** with nut **(13)** while checking that arm **B** stays locked.
36. Tighten nut **(14)**.  
**N.B. : Check that cable is not under stress after tightening.**
37. Check "direct transmission" position control locking.

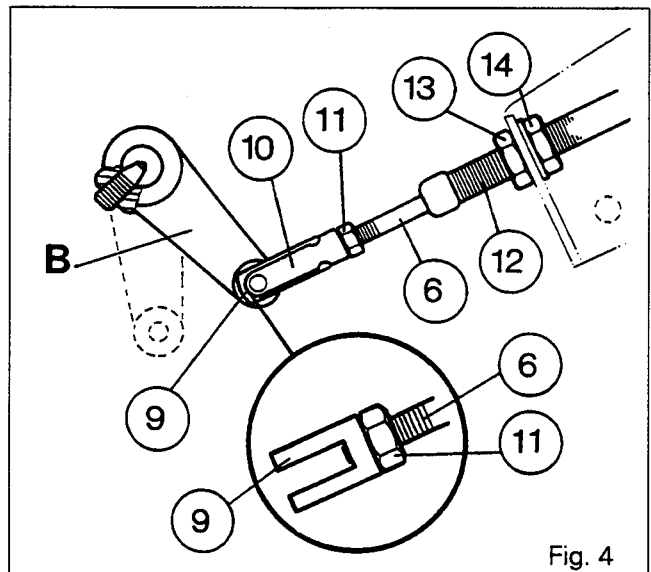
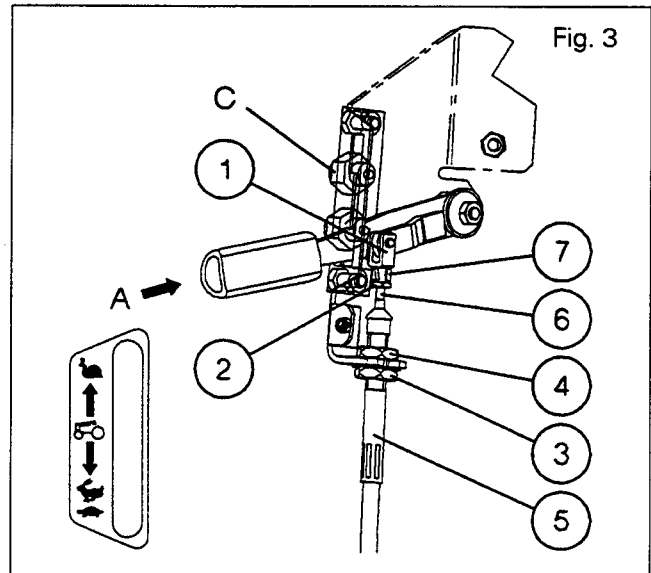



**Gearbox - Creeper gears**

**F . Circuit diagram**

**List of parts**

- 18.Hare light
- 50.Creeper speed switch
- 51.Relay
- 52.Blinker relay
- 53.Diode
- 54.Creeper speed light

**Abbreviations**

- TB.A7 : dashboard A connector pin 7
- TB.A16 : dashboard A connector pin 16

**Colour codes**

- G : Grey
- M: Brown
- N : Black
- C : Light
- F : Dark

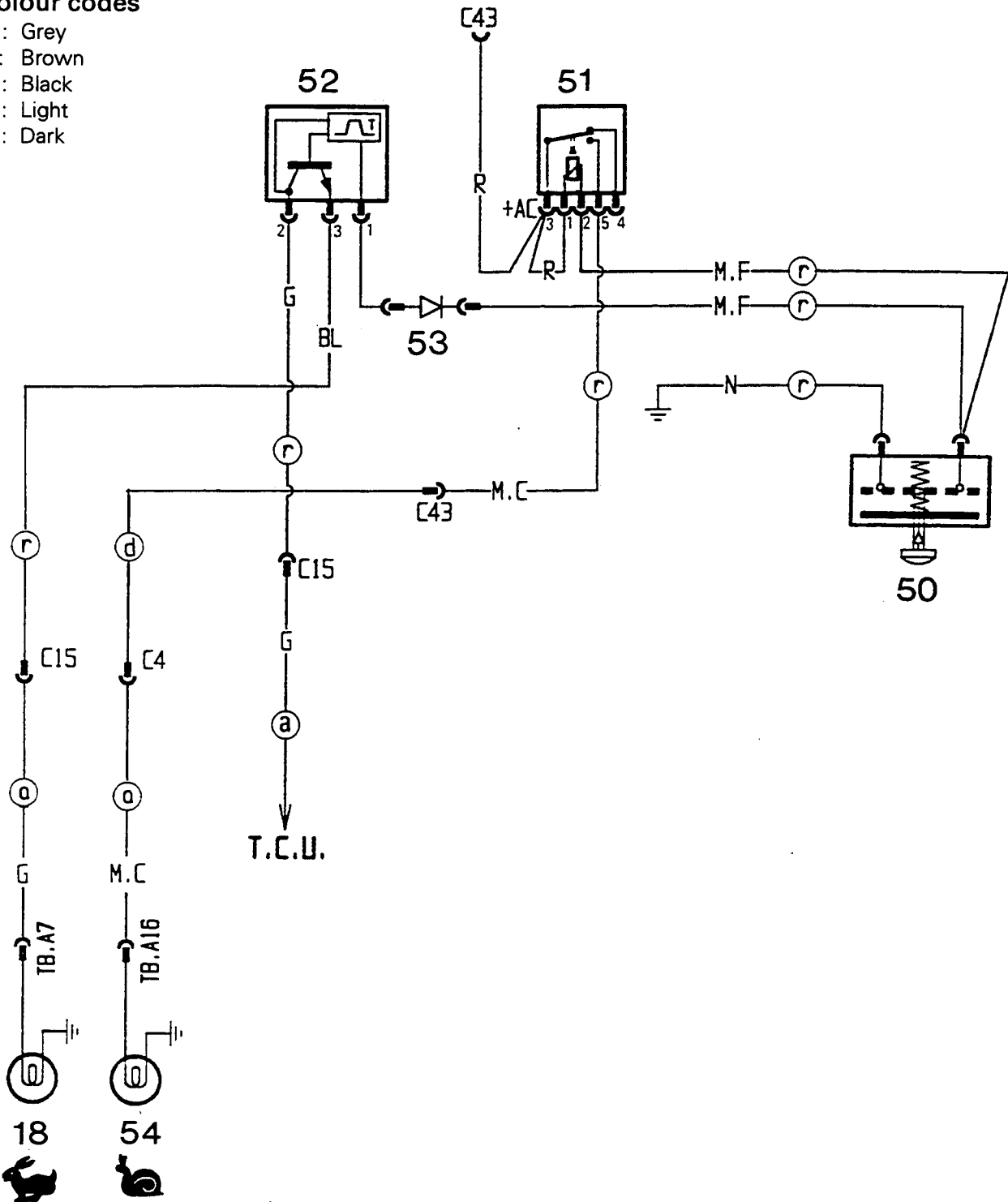





**Gearbox - Super creeper speeds**

*5 H02 Super creeper speeds*

CONTENTS

- <b>General</b> _____	<b>2</b>
- <b>Operation</b> _____	<b>2</b>
<b>A. Removing the accumulator</b> _____	<b>2</b>
<b>B. Refitting the accumulator</b> _____	<b>2</b>



5H02.2

---

## 6100 SERIES TRACTORS

---



# Gearbox - Super creeper speeds

---

### General

---

The tractors fitted with super creeper speeds use the same mechanical reduction assembly as the standard «creeper gear» version. This reduction gear is fitted behind the main box, on the output shaft (see chapter 5 H01).

They also use the reduction function of the hydro-mechanical device included in the input housing. In this configuration, the following modifications have been made (Fig. 1):

- planet wheels / sun wheels reduction ratio increased.
  - special hydraulic cover /25/, with a larger clutch piston.
- In addition, a hydraulic accumulator is fitted to the right-hand side of the box.

---

### Operation

---

Moving lever A to the snail position (Fig. 2) causes, at the same time, engagement of the two reduction devices.

The switch (1) closes the solenoid valve which controls the hydro-mechanical reduction device (input housing) putting the forward reduction device into the Tortoise range.

At the same time, the rear mechanical reduction gear goes into the slow position (see chapter 5 H01).

The movement of the two reduction devices into the Tortoise range drives the rear axle connecting shaft at a speed of 1 revolution per 7.8 revolutions of the box input shaft. When lever A is moved back to the Hare position, the transmission of movement is direct (ratio of 1:1). The tractors having the «super creeper speeds» version are fitted with an accumulator (Fig. 3) connected to the pipe (2) coming from the 17 bar valve. The purpose of this is to reduce the pressure drop when the super creeper range is engaged. This device is held by a bracket fixed to the selection cover.

---

### A . Removing the accumulator

---

1. Remove bolt (3)
2. Disconnect union (4)
3. Remove accumulator (5)
4. Remove fixing bracket (6)

---

### B . Refitting the accumulator

---

1. Reverse operations 1 to 4.

**Note: Apply a sealant between the union and accumulator (Loctite 542 or equivalent).**

**For correct operation, maintain nitrogen inflation pressure of 8 bar, using the valve (7) (Fig. 3).**

**Pressure to be checked once a year.**



# Gearbox - Super creeper speeds

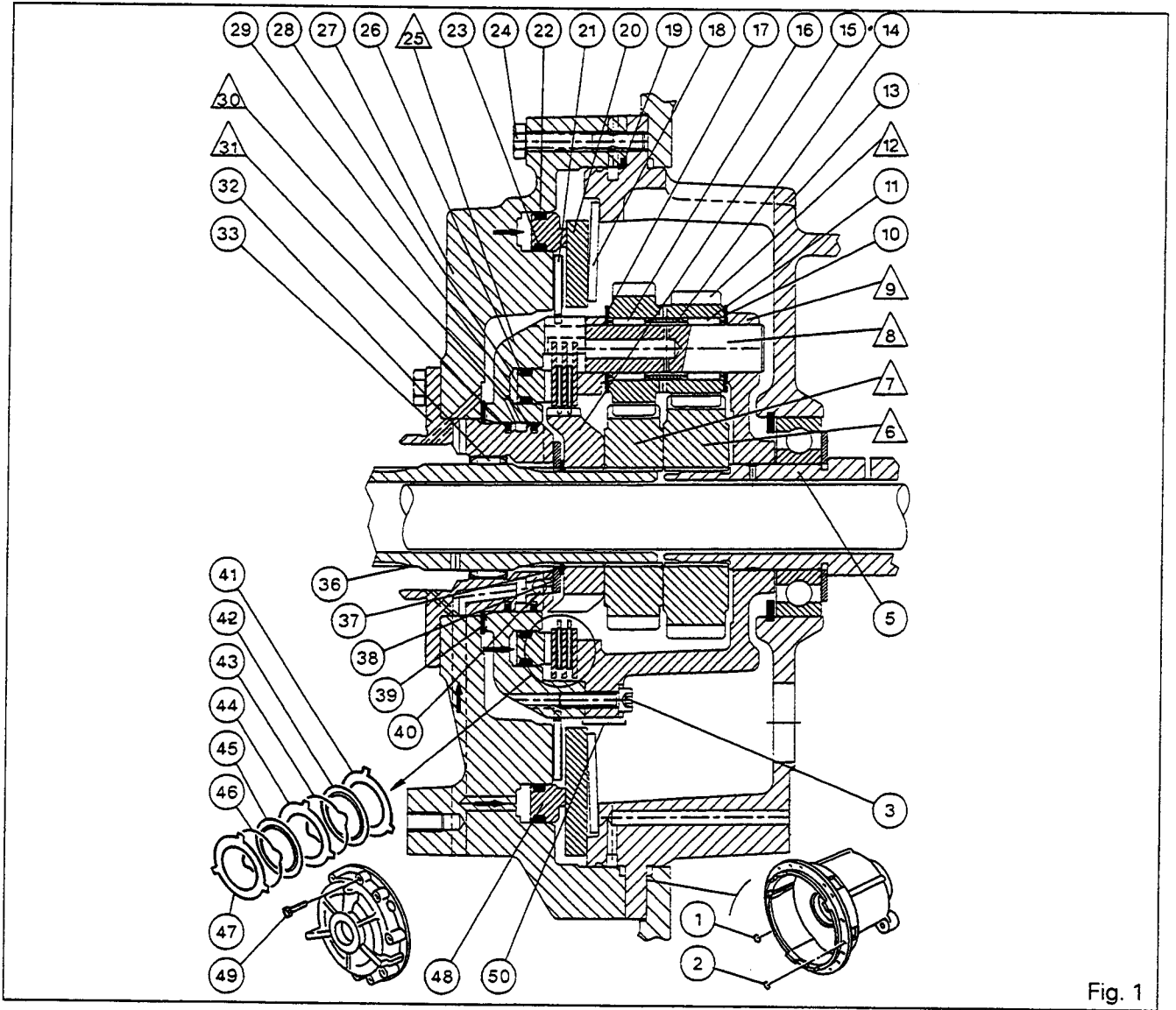

Fig. 1

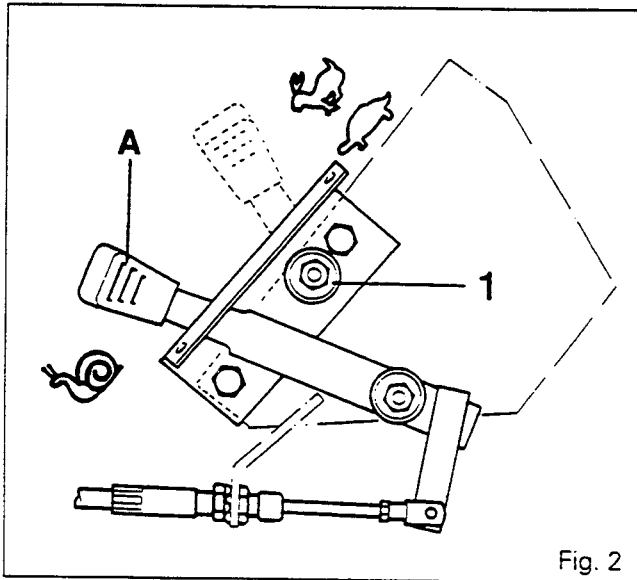

Fig. 2

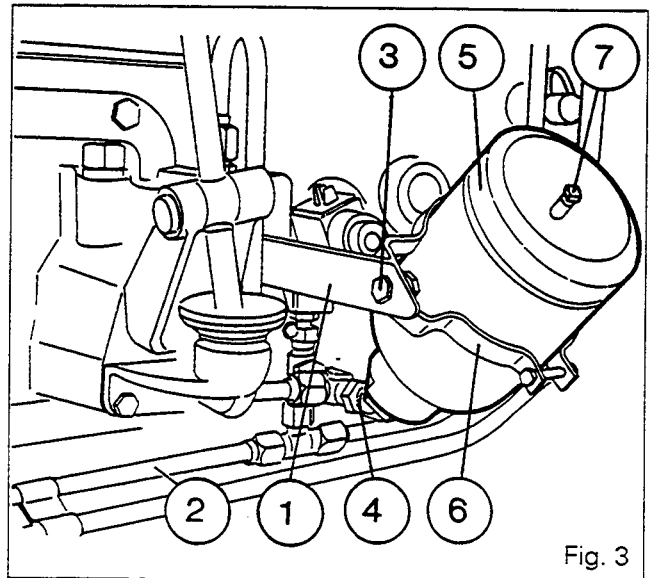

Fig. 3







## **6 . REAR AXLE**

### **Contents**

- 6 A01 DESCRIPTION**
- 6 B01 LIFT COVER**
- 6 C01 TRUMPET HOUSINGS**
- 6 C02 HEAVY DUTY TRUMPETS**
- 6 D01 HANDBRAKE**
- 6 E01 DIFFERENTIAL**
- 6 F01 BRAKE PISTON AND SEALS**





---

6100 SERIES TRACTORS

---



6A01.1

**Rear axle - Description**

*6 A01 Description of rear axle*

CONTENTS

-	<b>General</b> _____	<b>2</b>
A.	<b>Centre housing assembly</b> _____	<b>2</b>



6A01.2

---

## 6100 SERIES TRACTORS

---



### Rear axle - Description

---

#### General

---

The rear axle comprises four main housings :

- The centre housing which houses the differential, the power take-off gear in all variants and the 4-wheel drive transmission, the handbrake and main brake control unit. It also supports the two axle housings (trumpets), the lift cover and the side covers (see sections 9 I01-02).
- The right and left trumpets fixed to each side of the centre housing, serving as a rear wheel drive axle case (see sections 6C01-02).
- The lift cover fitted to the top of the centre housing supporting the lift arms which are attached to the lower links (see section 6B01).

---

#### A. Centre housing assembly

---

##### Differential

The driving pinion is driven from the gearbox output shaft through a connecting shaft with splined couplers. The crownwheel and pinion assembly transmits the drive through a differential to the final reduction units. A differential lock system actuated by hydraulic pressure is incorporated into the casing (see section 6 E01). The differential lock is controlled by the Autotronic.

##### 4-wheel drive clutch

A gear splined to the driving pinion drives the 4 WD clutch assembly.

Motion is then transmitted via Belleville washers to the clutch output shaft (see section 8 A01).

It is hydraulically actuated to disengage the 4 WD. There is therefore no possibility of accidental disengagement of 4 WD in the event of hydraulic failure.

##### Power take-off drive

The rotation of the shaft passing through the gearbox, proportional to the engine speed, is transmitted to the hydraulic clutch located at the front of the centre housing (see section 7 E01).

In the engaged position drive is transmitted by a countershaft and a set of driving and driven gears to the 540 or 1000 rpm power take-off shaft. Speeds are selected by a system of interchangeable shafts (see section 7 B01) or by coupler (see section 7 C01).

A hydraulic braking device stops the rotation of the power take-off shaft in the disengaged position.

Two additional options are offered :

- (economy) 4 speed power take-off (see section 7 A01).
- power take-off proportional to forward speed (GSPTO) (see section 7 D01).

##### Handbrake assembly

A brake assembly comprising two plates and an expander mechanism is mounted on the driving pinion (see section 6 D01).

##### Main brakes

Two pistons mounted laterally in two cavities in the centre housing act on two discs splined onto the output shafts. The brake pistons are activated hydraulically (see section 6 F01).



6100 SERIES TRACTORS

**Rear axle - Description**



**Centre housing assembly  
(longitudinal cross-section)**

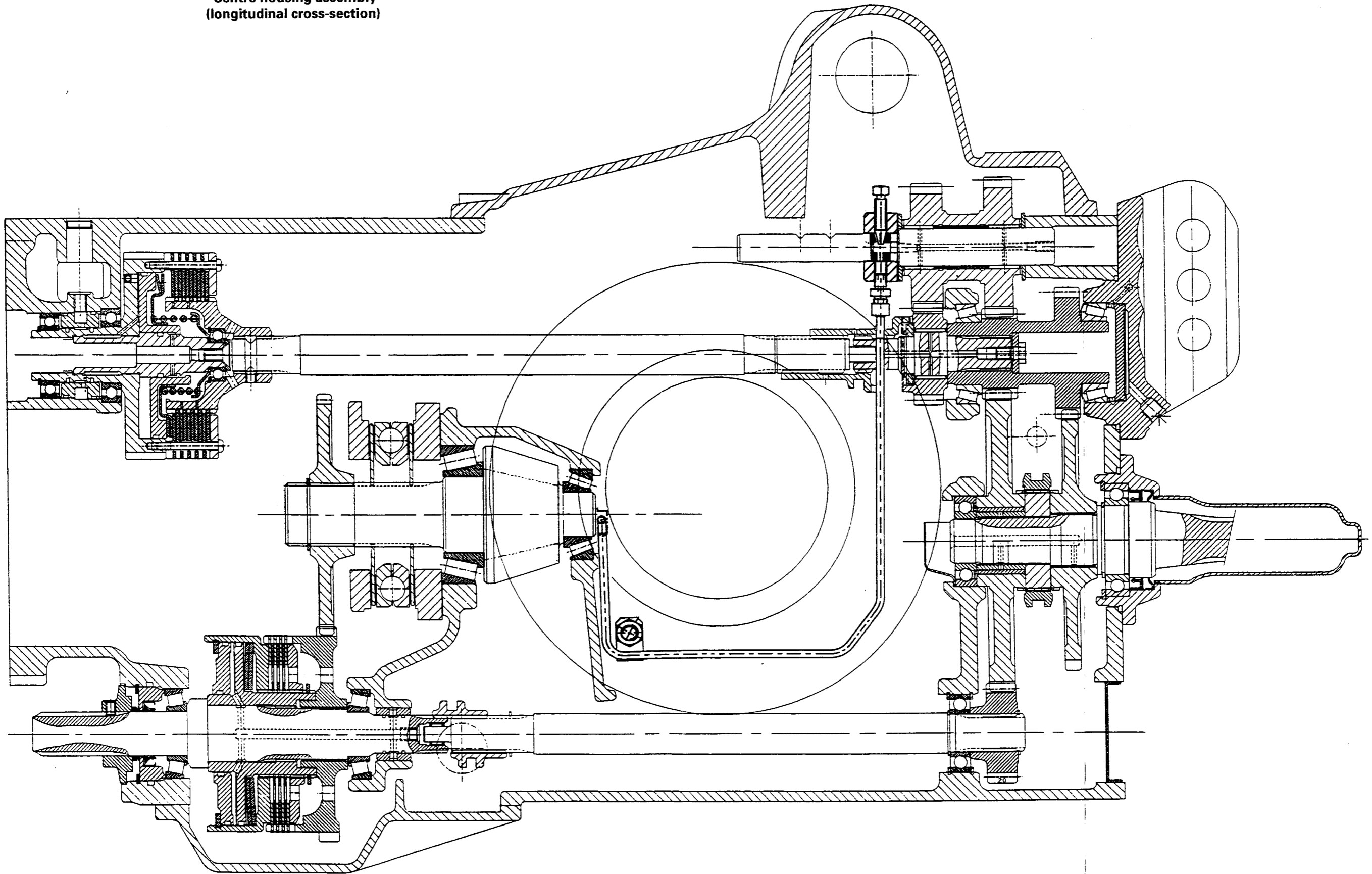



6A01.4

6100 SERIES TRACTORS

# Rear axle - Description



Centre housing assembly

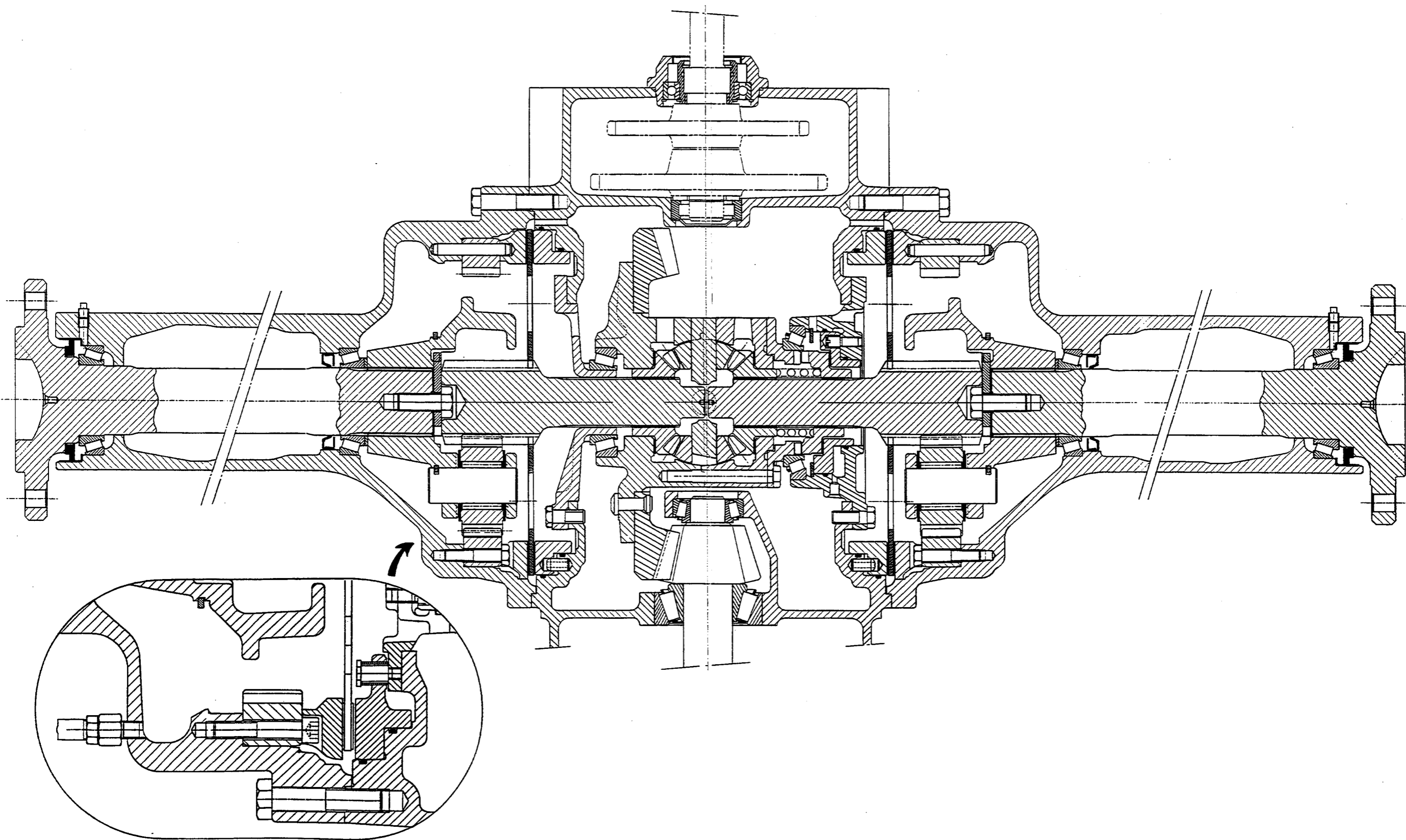



---

6100 SERIES TRACTORS

---



6B01.1

**Rear Axle - Lift cover**

6 B01 Lift cover

CONTENTS

- General	_____	2
A. Removal	_____	5
B. Disassembly	_____	6
C. Reassembly	_____	7
D. Refitting	_____	9





6B01.2

---

**6100 SERIES TRACTORS**

---

**Rear Axle - Lift cover**

---

**General**

---

The lift cover is mounted on the upper face of the rear axle housing. The shaft **(4)** which has the two lift arms **(5)** and **(11)** splined to it, is supported by bushes **(8)**.

Cam **(9)** on the lift shaft **(4)** provides the means for sensor **(26)** to monitor position of lift arms. This information is transmitted to the Electronic Linkage Control (ELC) system.

To ensure correct play between the lift arms and the cover, shims **[12]** are fitted on the left hand end of the shaft.

To avoid seizure, two thrust washers **(30)** are fitted between the lift arms and the lift cover.

The rear face of the lift cover supports the auxiliary spool valves. The vehicle speed sensor **(15)** is screwed in the front of the cover. The cover also supports lever **(21)** for economy ( 4 speed) PTO, if fitted.

**List of parts**

- |                                  |  |
|----------------------------------|--|
| <b>(1)</b> Washer                | <b>(16)</b> Nut                          |
| <b>(2)</b> Bolt                  | <b>(17)</b> Cup plug (2-speed PTO)       |
| <b>(3)</b> Retainer              | <b>(18)</b> Screw (4-speed PTO)          |
| <b>(4)</b> Lift shaft            | <b>(19)</b> Control finger (4-speed PTO) |
| <b>(5)</b> Right-hand lift arm   | <b>(20)</b> O-ring (4-speed PTO)         |
| <b>(6)</b> Nylon ring (2)        | <b>(21)</b> Lever (4-speed PTO)          |
| <b>(7)</b> O-ring (2)            | <b>(22)</b> Screw (4-speed PTO)          |
| <b>(8)</b> Bush (2)              | <b>(23)</b> Elbow connector              |
| <b>(9)</b> Cam                   | <b>(24)</b> Bolt                         |
| <b>(10)</b> Lift cover           | <b>(25)</b> Nut                          |
| <b>(11)</b> Left-hand lift arm   | <b>(26)</b> Position sensor              |
| <b>[12]</b> Shim(s)              | <b>(27)</b> Cup plug without lift        |
| <b>(13)</b> Bush                 | <b>(28)</b> Threaded plug without lift   |
| <b>(14)</b> Set screw (2)        | <b>(29)</b> Seal without lift            |
| <b>(15)</b> Vehicle speed sensor | <b>(30)</b> Thrust washer                |



6100 SERIES TRACTORS

Rear Axle - Lift cover



6B01.3

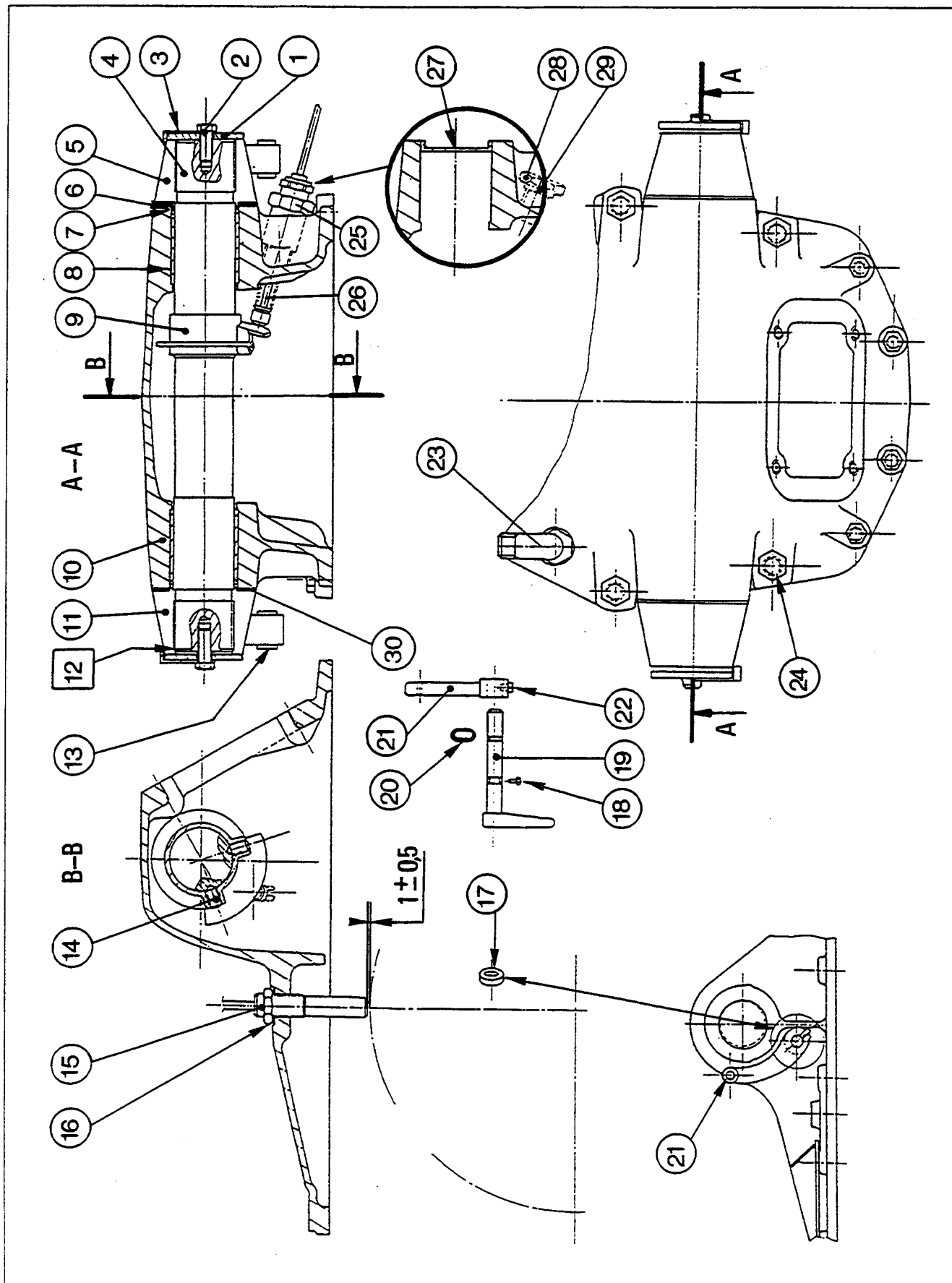



6B01.4

6100 SERIES TRACTORS

Rear Axle - Lift cover



Exploded view

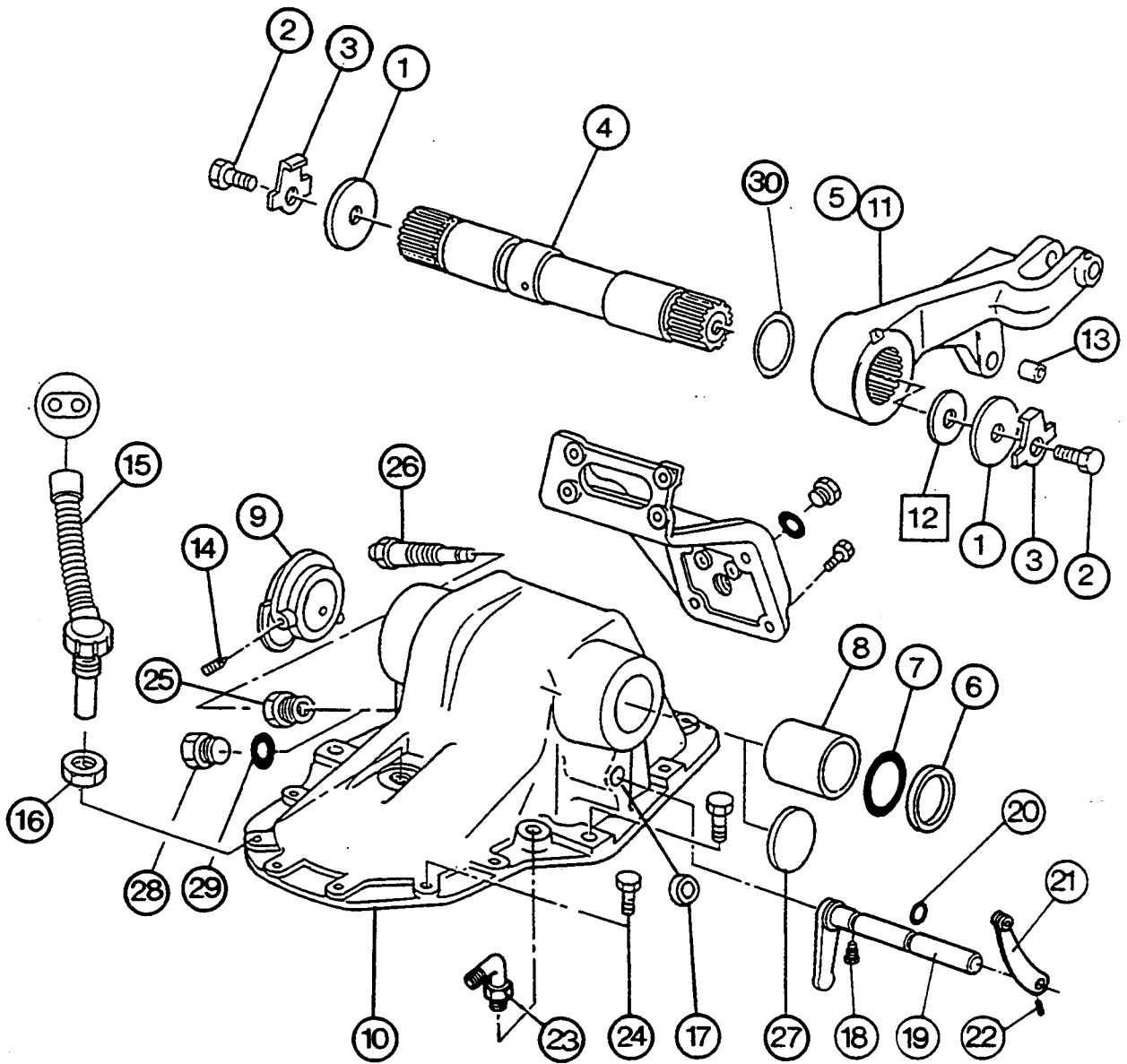



# Rear Axle - Lift cover

## A. Removal

1. Remove the sheetmetal.
2. Remove the rear fastening screws to the cab.
3. Raise the cab.
  - Note: Place a block between the cab and the trumpets (Fig. 1).**
4. Disconnect (Fig. 2) :
  - the supply hose (1) to the spool valve
  - the supply hose (3) to the lift valve
  - the return hose (2).
5. Remove the bolts (4) for the spool valve support (5) (Fig. 2).
6. Remove the support swinging the assembly out of the way, without disconnecting the controls (1) (Fig. 3).
7. Disconnect (Fig. 4):
  - the vehicle sensor wire assembly (1)
  - the position sensor wire assembly (2)
  - the differential lock pipe (3)
  - the cable (4) (4-speed PTO, if fitted)

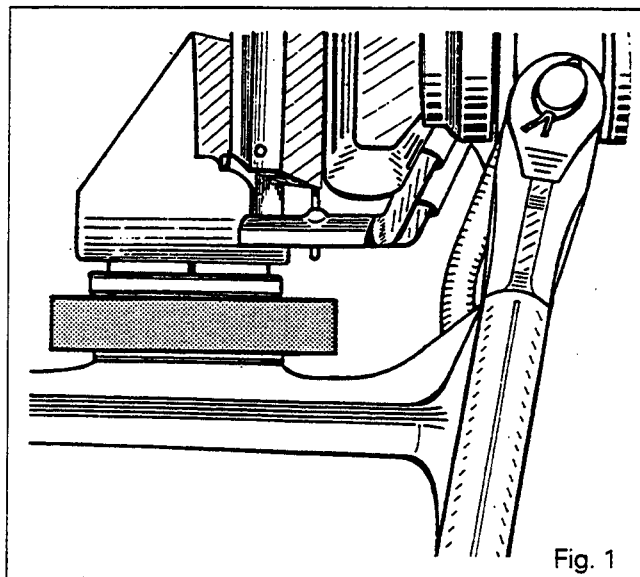

Fig. 1

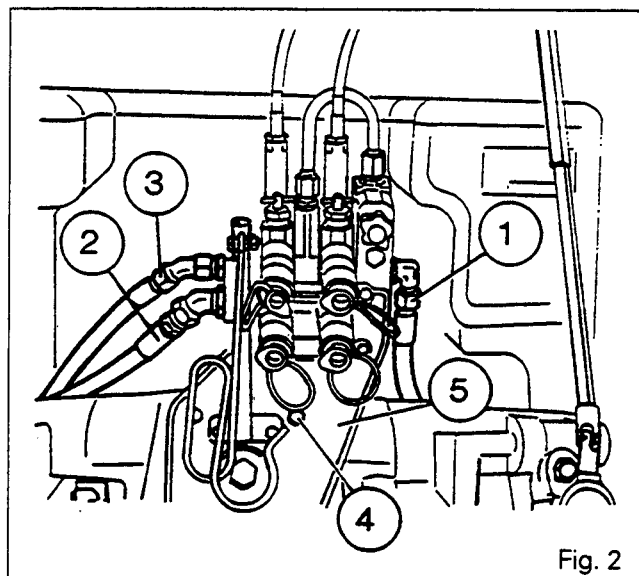

Fig. 2

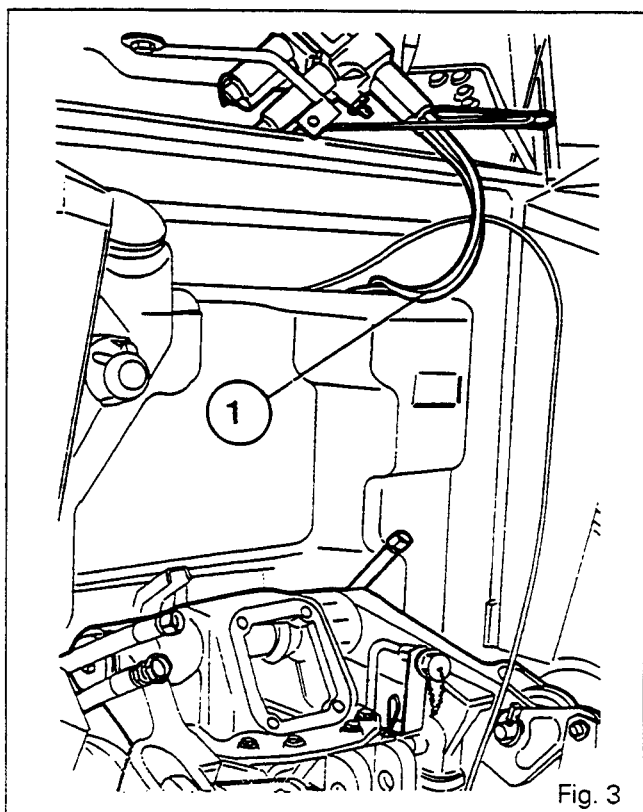

Fig. 3

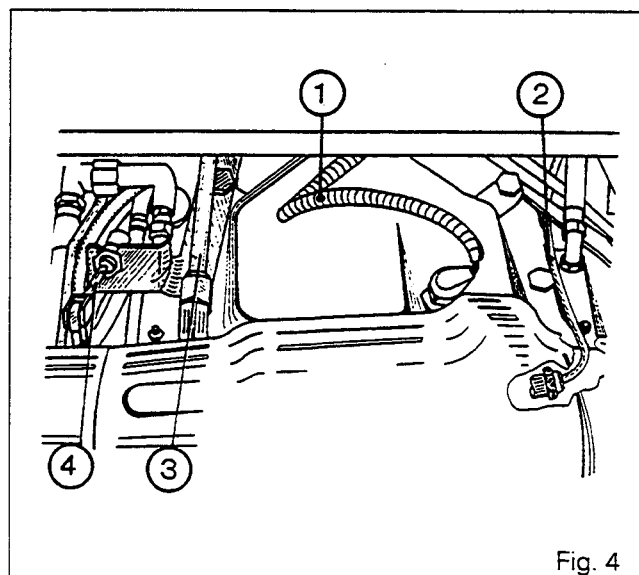

Fig. 4



6B01.6

## 6100 SERIES TRACTORS



## Rear Axle - Lift cover

8. Unscrew the pipe (1) at both ends and remove the support (2) for the trailer brake connector if fitted (Fig. 5).
9. Remove the upper pins from the rams and lift rods.
10. Remove the fastening bolts (24) for the cover (10).  
**Note: The p.t.o. control cable support (depending on the version) is fixed by the bolts of the cover.**
11. Lift the cover and remove it.

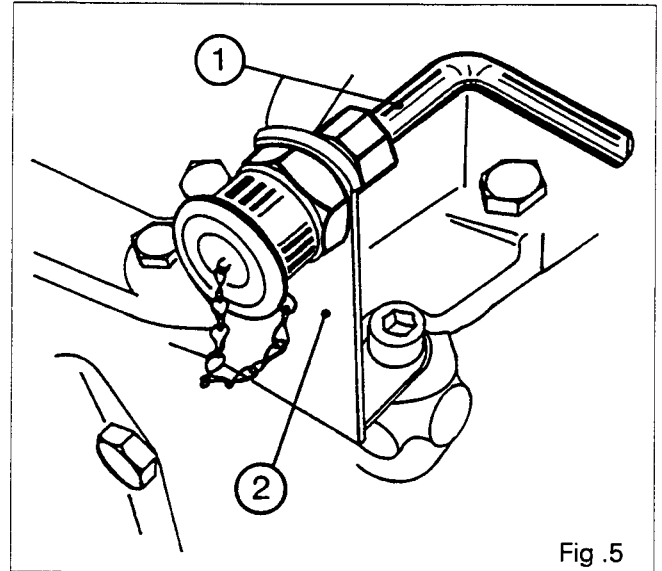

Fig. 5

## B. Disassembly

12. Place the cover on a work bench.
13. Remove the elbow connector (23).
14. Unscrew the nut (16) and remove the vehicle speed, sensor (15).
15. Unscrew the nut (25) and remove the position sensor (26).

**For tractors equipped with economy 4-speed, carry out operations 16 to 19 (Fig. 6).**

16. Undo the Allen screw (22) in the lever (21).
17. Undo the screw (18).
18. Remove the control finger (19).
19. Remove the O-ring (20).
20. Flatten tabs locking the bolts (2) retaining the lift arms..
21. Undo the screws.
22. Remove the washers (1).
23. Remove the shim(s) [12].
24. Remove the lift arms (5) (11) and the thrust washers (30).
25. Remove the nylon rings (6) and the O-rings (7).
26. Remove the set screws (14) in the cam (9).
27. Withdraw the lift shaft (4) from the cover.
28. Remove the cam (9).
29. Withdraw the bushes (8) (Fig. 7).
30. Remove the cup plug (17) (2-speed PTO).

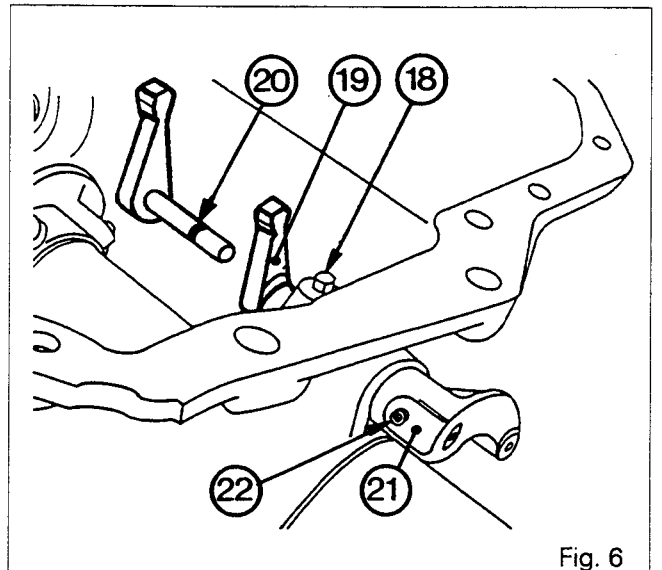

Fig. 6

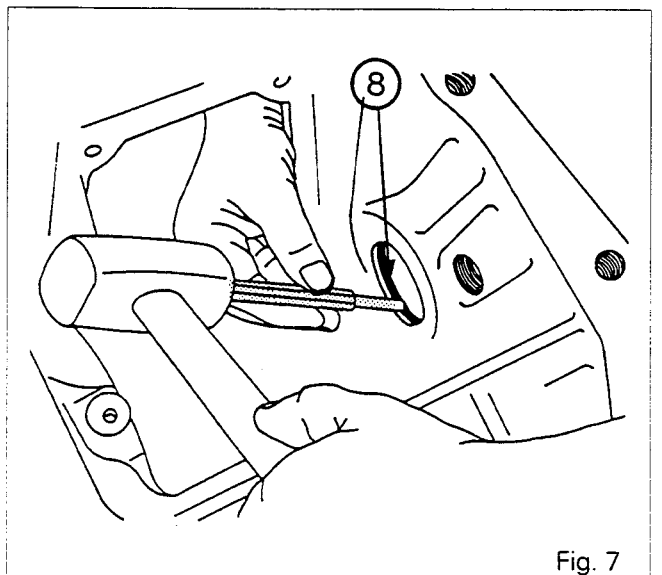

Fig. 7



## Rear Axle - Lift cover

### C. Reassembly

**Note:** The bushes (13) are mounted with Loctite 648 at a distance of 40.50 mm from the face A (Fig. 8).

31. Clean and check the parts. Replace any which are defective.
32. Clean the joint faces of the lift cover and of the spool valve support.
33. Fit the bushes (8) in the cover.
34. Fit the cup plug (17) smeared with Loctite 542 flush with the cover (2- speed p.t.o.).
35. Mount the lift shaft (4) and the cam (9) in the cover (Fig. 9).

**Note:** Ensure that the direction of the shaft and the position of the cam are correct.

36. Tighten the set screws (14) smeared with Loctite 241 to a torque of 5 Nm (Fig. 9).

**Note:** Apply this torque so as not to deform the cam.

37. Position the O-rings (7) and the nylon rings (6).
38. Grease the splines of the shaft (4) (Anti-Seize Grease or equivalent).
39. Fit the lift arm (5) (sensor side), the washer (1), the retainer (3) and the screw (2).

**Note:** Grease the face of the cover (Anti-Seize Grease or equivalent) before fitting the arms.

40. Tighten the screw (2) so as to align two flat sides of the screw head with the two tabs of the retainer (3). Bend back the tabs.

**Note:** If work has been done without the need to carry out shimming J1 (Fig. 12) (eg. replacement of seals) it is essential to place the shims [12] at the left end of the shaft (factory fitting) to preserve the correct positioning of the cam and avoid having to adjust the sensor (26).

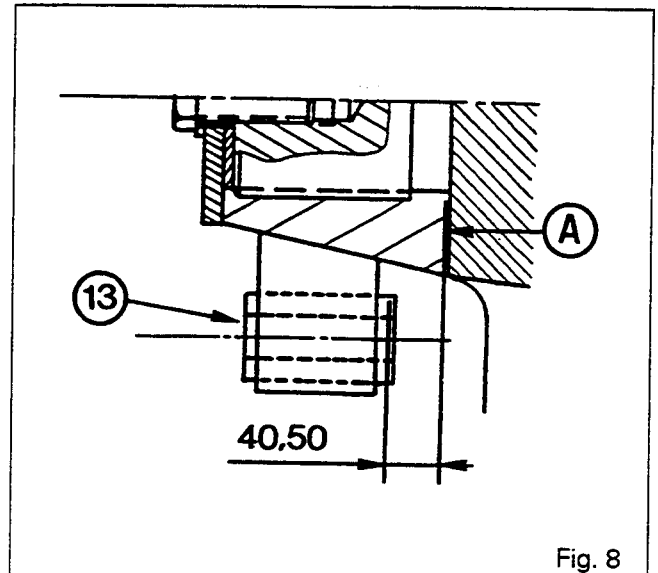

Fig. 8

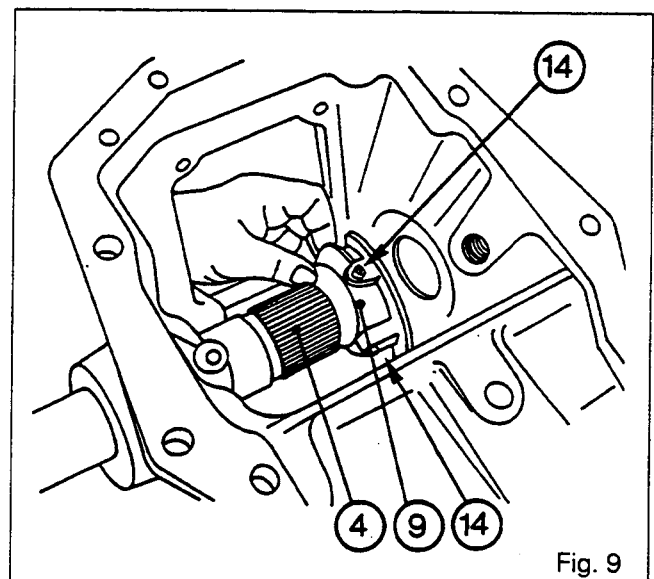

Fig. 9

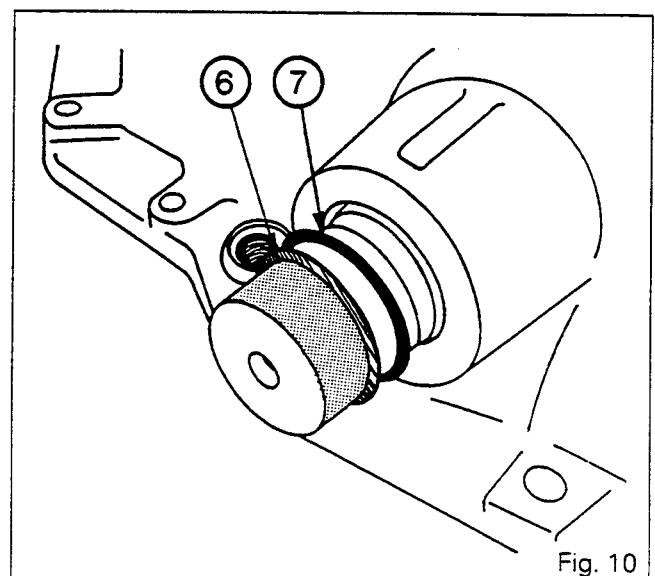

Fig. 10



6B01.8

## 6100 SERIES TRACTORS

**Rear Axle - Lift cover**

41. Carry out shimming of the shaft (4) (Fig. 12) to obtain end play :

**J1 = 0.05 to 0.20 maximum.**

Mount the arm (11), the washer (1) and the bolt (2).

**Note: Grease the face of the cover (Anti-Seize Grease or equivalent) before mounting the arm.**

42. Tighten the bolt so as to position the lift arms (5) and (11) correctly on the shaft.
43. Remove the bolt (2) and the washer (1) at the left end of the shaft.
44. Measure the distance between face A of the shaft and face B of the arm using a depth gauge (Figs. 11 and 12).
45. By measuring dimension X, determine the thickness of spacers Y needed to obtain (Fig. 12):  
**J1 = 0.05 to 0.20 maximum.**  
**J1 = X + Y**
46. Mount the previously selected shims [12], the washer (1), the retainer (3) and the bolt (2).
47. Tighten the bolt (2) so as to align two flat sides of the screw head with the two tabs of the retainer(3). Bend back the tabs.
- For tractors equipped with economy 4-speed PTO, carry out operations 48 to 51.**
48. Refit the finger (19) (Fig. 13).
49. Mount the O-ring (20) from the exterior side of the cover (Fig. 13).
50. Smear the screws (18) and (22) with Loctite 241 and tighten.
51. Check that the control functions smoothly.
52. Fit the elbow connector (23).

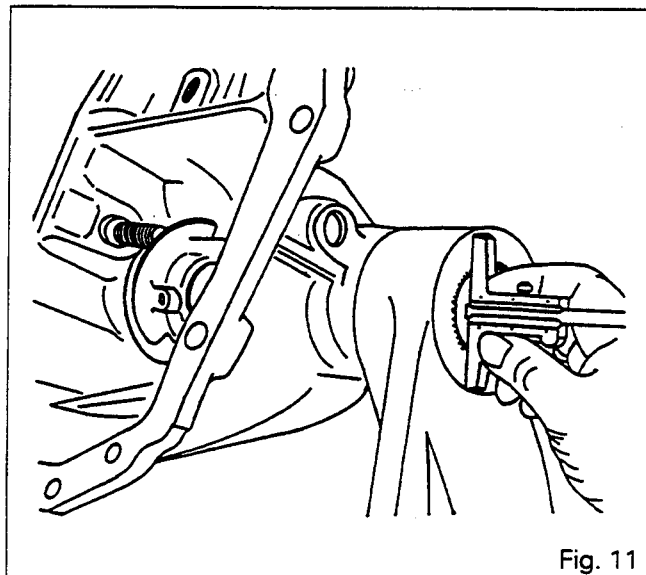

Fig. 11

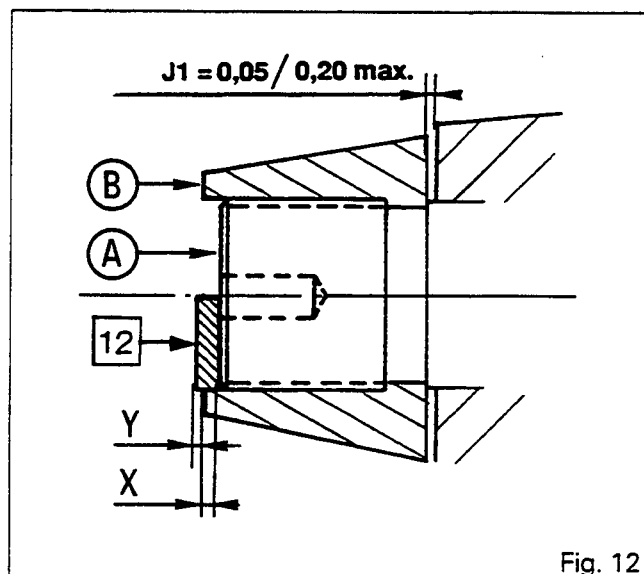

Fig. 12

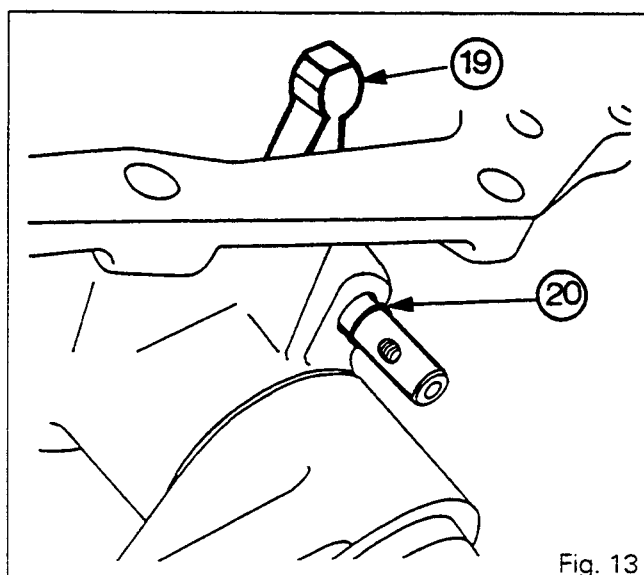

Fig. 13



## Rear Axle - Lift cover

### D. Refitting

53. Clean the joint face of the cover on the rear axle housing.
54. Smear the joint face with a sealing compound (Master Joint 510 Loctite or equivalent).
55. Lift cover into position.  
**Note : When refitting the cover, ensure that the supply pipe of the differential lock and the control finger (4-speed economy PTO) engage properly in their respective positions (Fig. 14).**
56. Mount the support for the PTO control cable (depending on the version) and fit the bolts (24) of the cover (10). Tighten to the following torque :
  - . 12mm diameter bolt = 72- 96 Nm
  - . 16mm diameter bolt = 160-200 Nm**Note : The 6190 tractor is fitted with a heavy duty lift shaft. The tightening torque of 16 diam. bolts is 240 - 320 Nm.**
57. Refit the upper pins to the rams and lift rods. Refit the trailer brake valve support if fitted. Retighten the pipe at both ends.
58. Refit (Fig. 4) :
  - . the differential lock supply pipe (3)
  - . the cable (4) (4-speed PTO, if fitted)
59. Fit the vehicle speed sensor (15) with "Loctite 577 Sensor Sealing" or equivalent (Autotronic, Datatronic tractors) (Fig. 15).
60. Screw in the speed sensor into contact with the crownwheel, without forcing it.
61. Unscrew the sensor 3/4 of a turn so as to obtain a clearance of approx. 1 mm between the sensor and the crownwheel (Fig. 15).
62. Tighten the nut (16) moderately (Fig. 15).
63. Connect the sensor.
64. Fix the harness assembly with a clip.
65. Clean the joint face of the spool valve support .
66. Coat the joint face of the spool valve support with a sealing compound (Master Joint 510 Loctite or equivalent).
67. Refit the support and spool valve assembly (1) (Fig. 16).

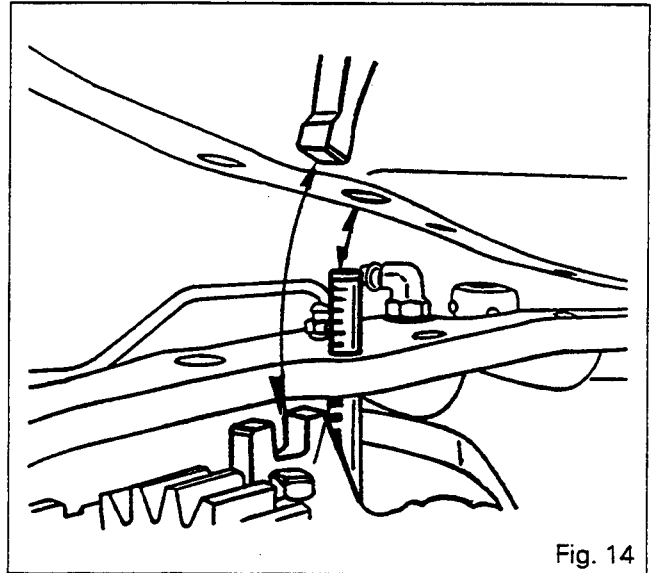

Fig. 14

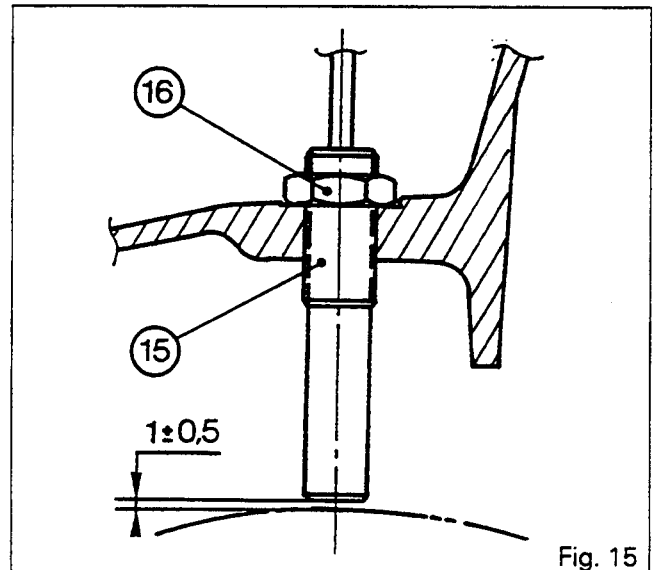

Fig. 15

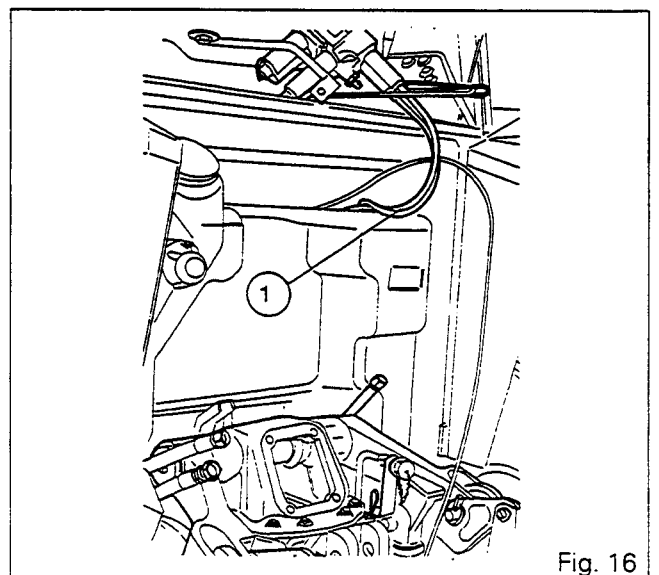

Fig. 16





6B01.10

# 6100 SERIES TRACTORS



## Rear Axle - Lift cover

- 68. Smear the thread of the two lower screws (4) with Loctite 510. Fit and tighten the bolts (4) in the spool valve support to a torque of 50-70 Nm (Fig. 2).
- 69. Reconnect (Fig. 2) :
  - . the supply hose (1) to the spool valve
  - . the supply hose (3) to the lift valve
  - . the return hose (2)
- 70. Adjust the p.t.o. control (4-speed) (section 7 A01).
- 71. Remove the blocks between the cab supports and the trumpets. Position the cab.
- 72. Refit the rear fastening screws of the cab. Tighten the nuts to 27-35 Nm and the lock-nuts smeared with Loctite 270 to 13-20 Nm.
- 73. Fit and adjust the position sensor.
- 74. Smear the thread of the sensor (26) with a sealing compound (Hylomar or equivalent), then screw in the sensor a few turns.
- 75. Start the engine.
- 76. Using the external control or pushing on the end of the raising solenoid, make sure that the lift arms are in the fully raised position (relief valve blowing). Stop the engine.
- 77. Screw in the sensor (without forcing it) until it meets the cam (9). Connect the sensor to the female connector of a locally made test harness as shown Fig. 17. Connect the other connector of the test harness to the tractor harness. Connect pins (1) and (2) to the MF 3005 multimeter. Lower the lower links of 3 to 5 cm at the ball ends or hook. Unscrew the sensor to obtain a voltage **between 6.92 and 6.96 volts**. Reconnect the tractor sensor.
- 78. Tighten the nut (25) to a torque of 25 Nm using a suitable spanner (Fig. 18).
- 79. Check for leaks:
  - . at the joint between the lift cover and the spool valve support
  - . at the hydraulic connectors.
- 80. Refit the sheetmetal.

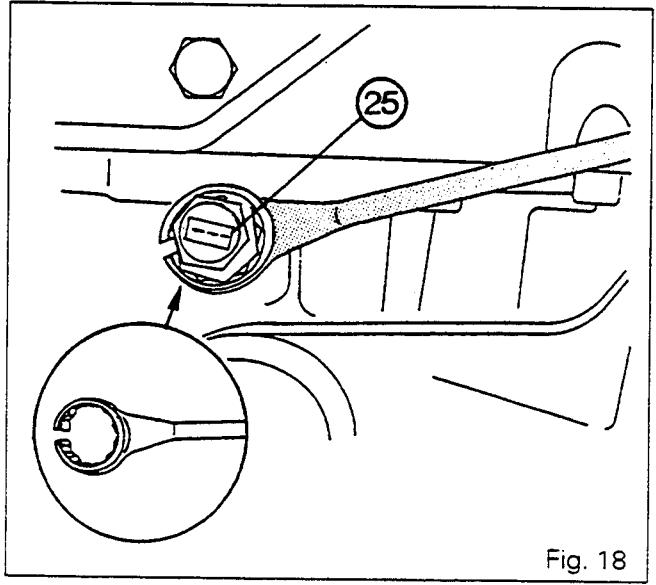
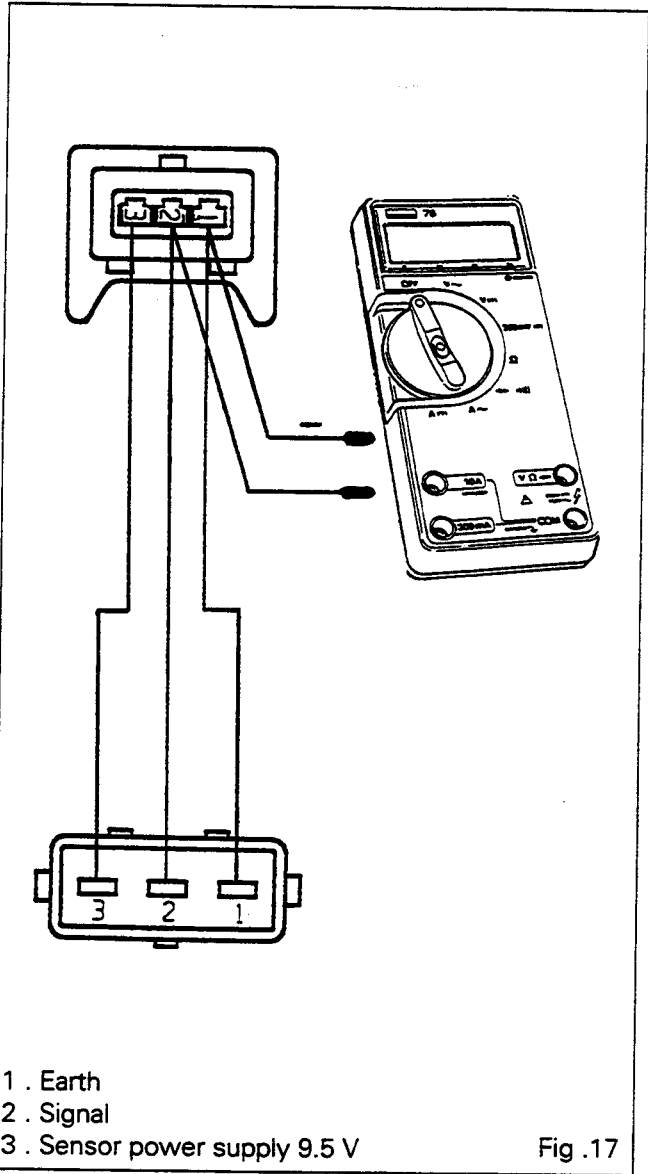

### Version without lift

- . The holes of the shaft (4) are plugged with caps (27) sealed with Loctite 542.
- . The position sensor (26) is replaced with a threaded plug (28) equipped with a seal (29).



**Rear axle - Trumpet housings**

6 C01 *Trumpet housings*

CONTENTS

. <b>General</b> _____	2
A. <b>Trumpet housing assembly</b> _____	5
B. <b>Planetary carrier assembly</b> _____	7
C. <b>Bearings and seals</b> _____	8
D. <b>Axle shaft bearings preload</b> _____	9
E. <b>Wheel stud replacement</b> _____	10



6C01.2

---

 6100 SERIES TRACTORS
 

---



## Rear axle - Trumpet housings

### General

#### Description

The trumpet housings support the RH and LH axle shafts and house the final reduction units which transmit the drive from the differential assembly.

There are two versions of the rear axle, normal and heavy duty, depending on the size of tractor : normal for the 6110 to 6140 tractors and heavy duty for the 6150 to 6170 tractors.

The two trumpet housings are symmetrical and are fitted on either side of the centre housing.

#### Construction

The half shaft **(2)** is supported by two taper roller bearings **(5)** and **(8)** fitted opposite each other. The unit is sealed on the outside by a triple lip seal **/3\** and on the inside by a single lip seal **/7\**. The final reduction planetary carrier assembly **(10)** fitted with three pinions **(14)** is splined onto the half shaft **(2)**.

The heavy duty planetary carrier assemblies comprise two rows of needle rollers **(16)** separated by a spacer **(15)**. The normal duty planetary carrier assemblies have only one row of needle rollers **(16)**. The recesses in carrier assemblies **(10)** are rough finished and require adjustment with suitable thickness thrust washers **[13]**.

Shims **[26]** located at the end of the axle shaft allow the taper roller bearing preload to be adjusted. The shaft **(2)** and the planetary carrier assembly **(10)** are held by the washer **(25)** and the bolt **(24)**. The ring gear **(22)** is a force fit in the trumpet housing and attached by three bolts **(17)**. It comprises three locating dowels **(21)** which centre the brake plate **(18)**.

Drive from the differential is transmitted to the final reduction planetary gears through a planetary shaft **(23)** on to which the brake disc **(19)** is splined.

As from serial number E240024, the brake discs are lubricated by a continuous oil flow from the lubricating system (closed centre) (see General, section 6F01).

#### List of parts

- |  |  |
|--|--|
| <b>(1)</b> Wheel stud                  | <b>(14)</b> Planetary gear                                 |
| <b>(2)</b> Axle shaft                  | <b>(15)</b> Spacer (heavy duty planetary carrier assembly) |
| <b>/3\</b> Triple lip seals            | <b>(16)</b> Needle rollers                                 |
| <b>(4)</b> Seal housing                | <b>(17)</b> Bolt   |
| <b>(5)</b> Bearing cup                 | <b>(18)</b> Brake plate                                    |
| <b>(5A)</b> Bearing cone               | <b>(19)</b> Brake disc                                     |
| <b>(6)</b> Trumpet housing             | <b>(20)</b> Bolt   |
| <b>/7\</b> Seal                        | <b>(21)</b> Locating dowel                                 |
| <b>(8)</b> Bearing cup                 | <b>(22)</b> Ring gear                                      |
| <b>(8A)</b> Bearing cone               | <b>(23)</b> Planetary shaft                                |
| <b>(9)</b> Spur washer                 | <b>(24)</b> Bolt   |
| <b>(10)</b> Planetary carrier assembly | <b>(25)</b> Washer   |
| <b>(11)</b> Circlip                    | <b>[26]</b> Shim(s)  |
| <b>(12)</b> Planetary gear pin         | <b>(27)</b> Locating dowel                                 |
| <b>[13]</b> Thrust washer(s)           | <b>(28)</b> Plug   |



6100 SERIES TRACTORS



6C01.3

Rear axle - Trumpet housings

Overall view

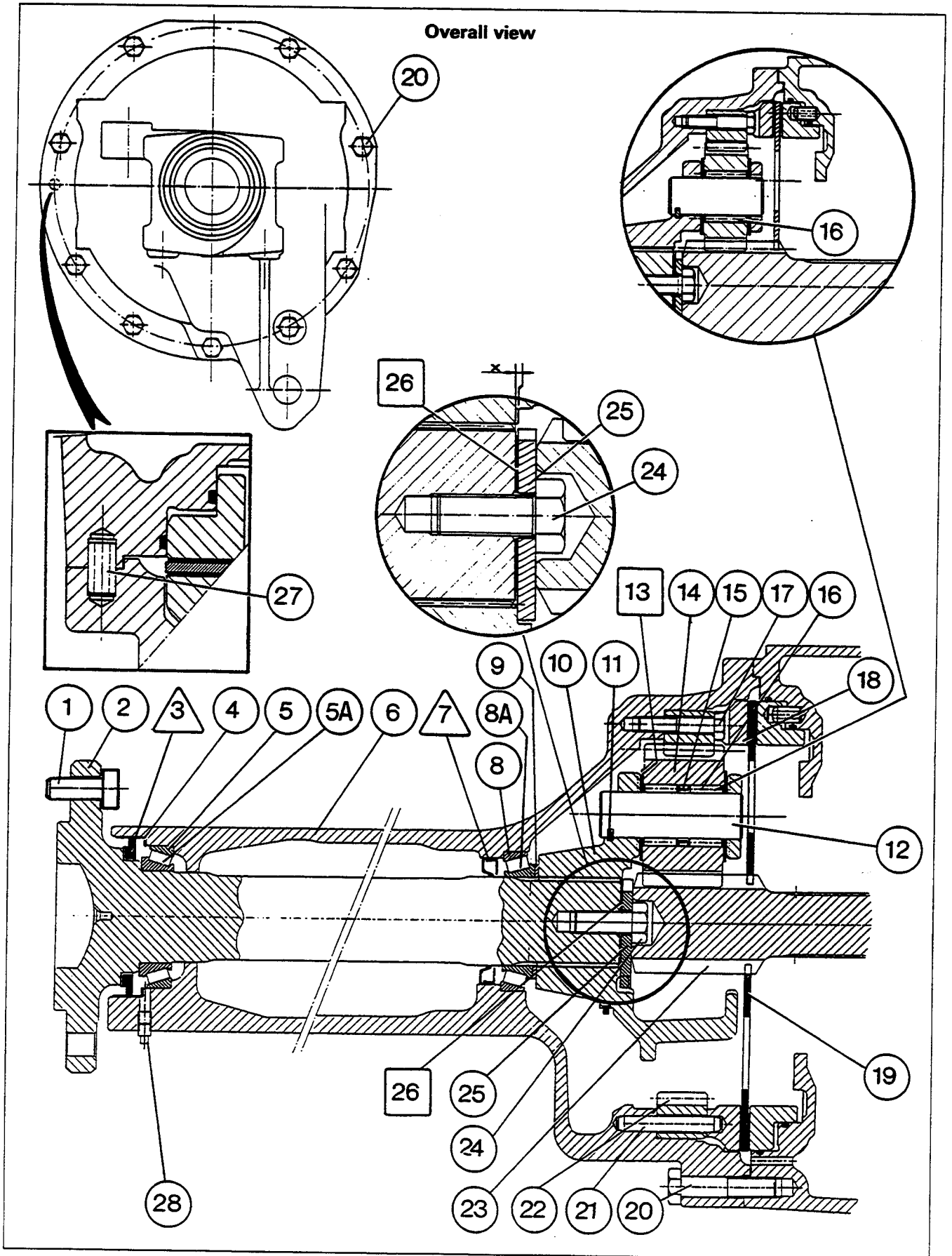



6100 SERIES TRACTORS



6C01.4

Rear axle - Trumpet housings

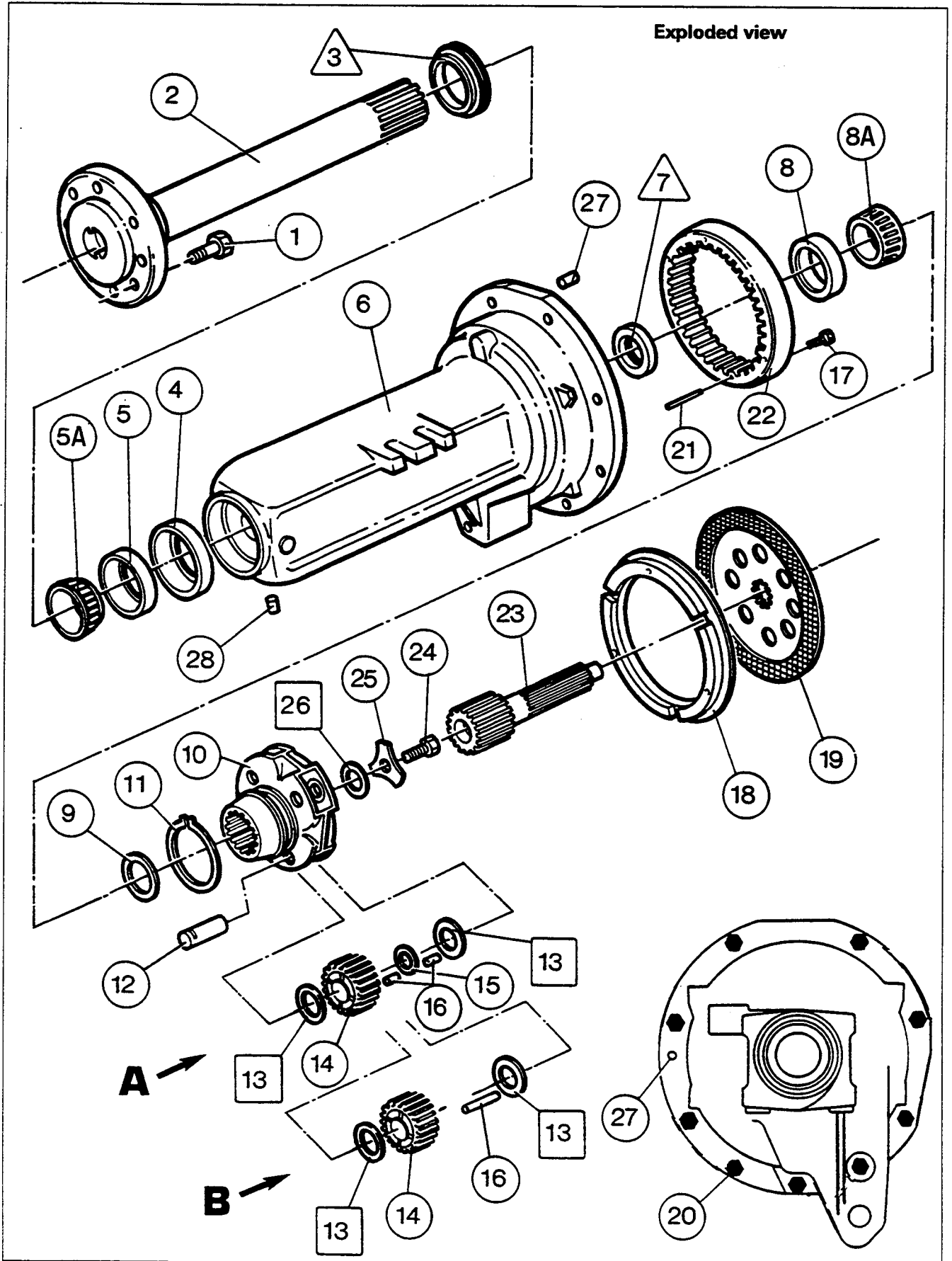



## Rear axle - Trumpet housings

### A. Trumpet housing assembly

#### Removal

1. Immobilize the tractor. Apply the handbrake. Fit chocks between the frame and the front axle (see 2 A01 Fig 1).
2. Drain the rear axle only.
3. Using a trolley jack, raise the side of the tractor involved.
4. Support the tractor with an axle stand.
5. Remove the wheel.
6. Remove the stabilizer bracket
7. Disconnect the draft control sensor harness. On tractors fitted with an **automatic hitch**, the sensor is removed **towards the outer side of the tractor** (Fig. 1A).
8. As from serial number E240024 (open centre), disconnect the hose (1) and the brake lubricating pipe or pipes (11) (according to the side concerned) (Fig. 1B).
9. Remove the cab attaching bolts (A) (Low profile cab Fig.2) - (Hiline cab Fig.3).
10. Raise the cab sufficiently to prevent any fouling when the trumpet housing is removed (chock the cab).  
**Important: Check the clearance between the hood and the windscreen (if insufficient remove the sheet metal).**
11. Remove the spacer (B) (Fig.2 low profile cab).  
**Note: Only for trumpet housing replacement on hiline cab tractors, remove bolts (A) and (C) and the spacer B (Fig.3).**
12. Position a suitable support on a trolley jack under the trumpet housing.
13. For the LH trumpet housing disconnect the lift hydraulics valve supply hose (plug the ends).
14. Unscrew the attaching bolts (20).
15. Pull the trumpet housing away from the rear axle housing.

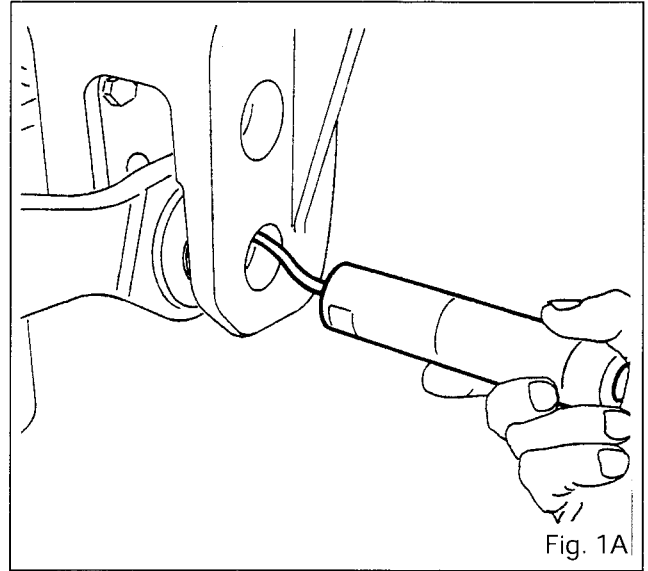

Fig. 1A

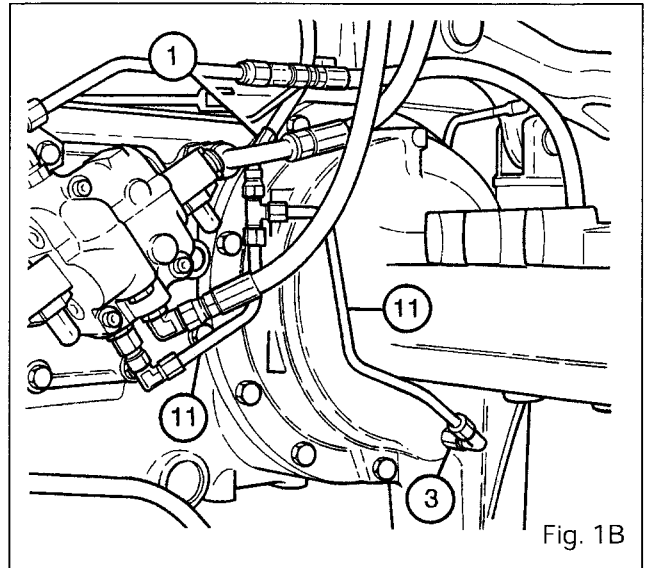

Fig. 1B

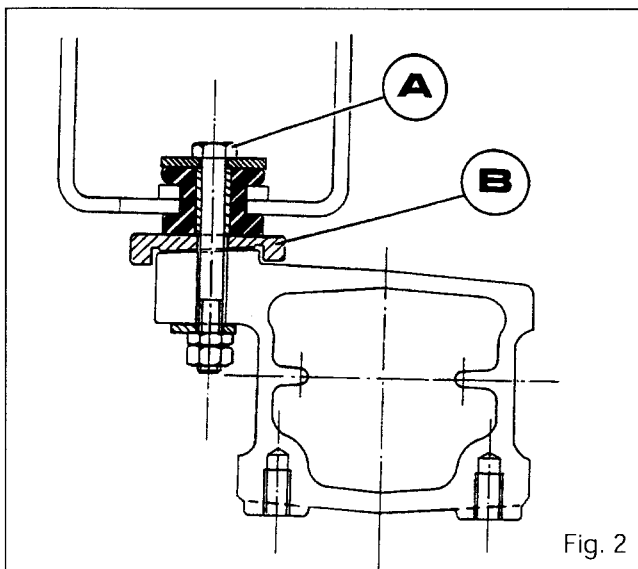

Fig. 2

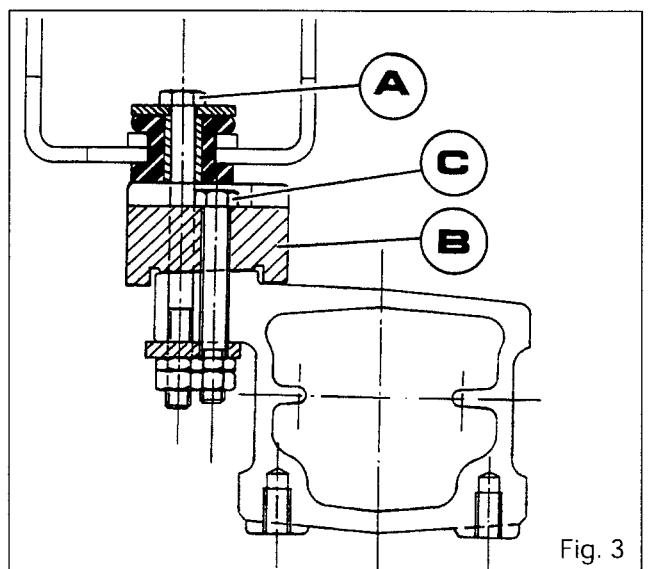

Fig. 3



6C01.6

## Rear axle - Trumpet housings

16. Remove :

- . the brake disc (19)
- . the planetary shaft (23)
- . the locating dowel (27)

**Note :** Prior to serial number E240024, to prevent the brake piston (C) from coming out of the housing, it is recommended that two wide washers and two bolts be fitted diametrically opposite each other to hold it in place. (Fig.4)

17. Remove the brake plate (18).

### Refitment

18. Clean the mating faces of the centre housing and the trumpet housing with a non-greasy solvent.

19. Apply a bead of oil resistant (Silicomex type) silicone to the inner edge of the centre housing (Fig.5).

20. Check that the disk (19) slides freely on the planetary shaft (23) (Fig.6).

21. Refit the locating dowel (27), the planetary shaft (23) and the brake disc (19).

22. Screw two dowel pins into diametrically opposite positions on the centre housing.

23. Refit the brake plate (18) in the trumpet housing.

**Note:** To retain the plate, apply three spots of "Amber Technical" grease or an equivalent product to the surface of the ring gear (22).

24. Attach the trumpet housing to the rear axle assembly.

**Note:** Turn the shaft (2) to engage the planetary shaft (23) in the planetary gears.

25. Clean the bolts (20) and coat them with Plastex, Hylomar or an equivalent gasket sealant.

26. Fit and tighten the bolts (20) to a torque of 170-210 Nm.

27. Carry out procedures 12 and 13 in reverse.

28. Carry out procedures 10 and 11 in reverse.

29. Refit the cab attaching bolts with the nuts and locknuts to a torque of :

Nut : 27-35 Nm

Locknut : 13-20 Nm (with Loctite 270)

30. Refit the draft control sensor after lightly coating it with Loctite Anti-seize grease or equivalent.

31. Reconnect the draft control sensor, the hose (1), and the pipe or pipes (11) to the restrictor coupling (3) (Fig. 1B) and reinstall the stabiliser bracket.

32. Fill the rear axle assembly with oil.

33. Refit the wheel. Tighten to a torque of 400-450 Nm.

34. Remove the axle stand.

35. Test the hydraulic lift and brake circuits.

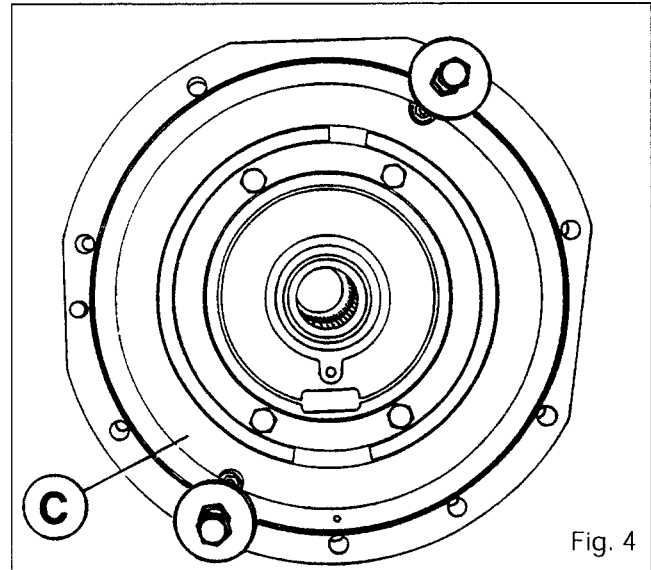

Fig. 4

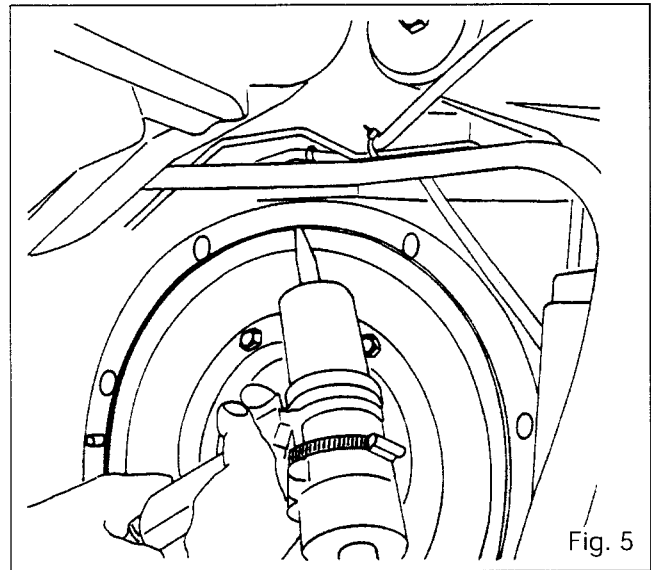

Fig. 5

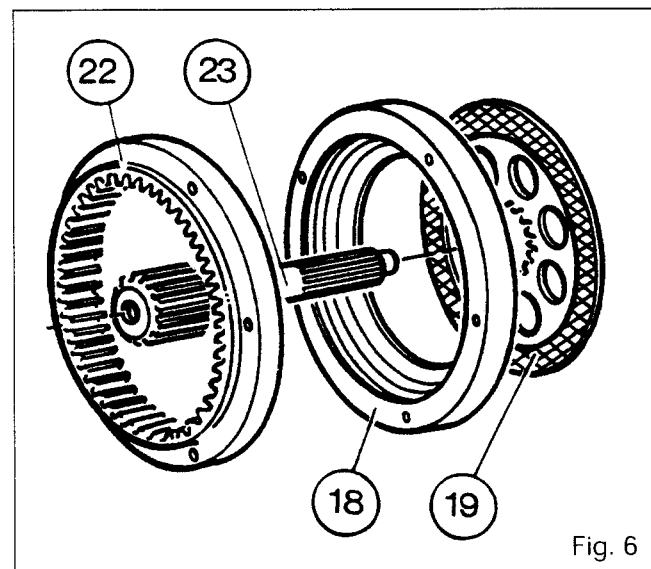

Fig. 6



## Rear axle - Trumpet housings

### 36. Check for leaks :

- between the trumpet housing and the rear axle housing
- from the lift system valve supply hose (LH trumpet housing)
- from the brake lubricating pipes

## B. Planetary carrier assembly

### Disassembly

1. Remove the trumpet housing (see Section A).
2. Remove the bolt (24).
3. Remove the retaining washer (25) and the shim(s) [26] (Fig. 7).
4. Remove the planetary carrier assembly (10).
5. Open out the circlip (11) (Fig. 8).
6. Using a copper tipped mallet, tap lightly on the three pins (12) (Fig. 8).
7. Remove the three pins (12) and the circlip (11).
8. Remove the three planetary gears (14), the needle rollers (16), the spacers (15) (heavy duty planetary gear A) and the thrust washers [13].

### Reassembly

9. Clean the planetary carrier (10), the pins (12) and the planetary gears (14). Check the condition of the parts.
10. Coat the needle rollers (16) with "Amber Technical" or an equivalent grease. Into each planetary gear (14) insert :
  - Heavy duty planetary carrier (A) : two rows of needle rollers separated by a spacer (15) (Fig. 7).
  - Normal duty planetary carrier (B) : one row of needle rollers (Fig. 7).
11. Shim the planetary gears.  
**Note: Three thicknesses of thrust washer [13] are available.**
12. Position the planetary gears (14) and the medium thickness washers [13] on each side of the planetary gear.
13. Fit the three pins (12).

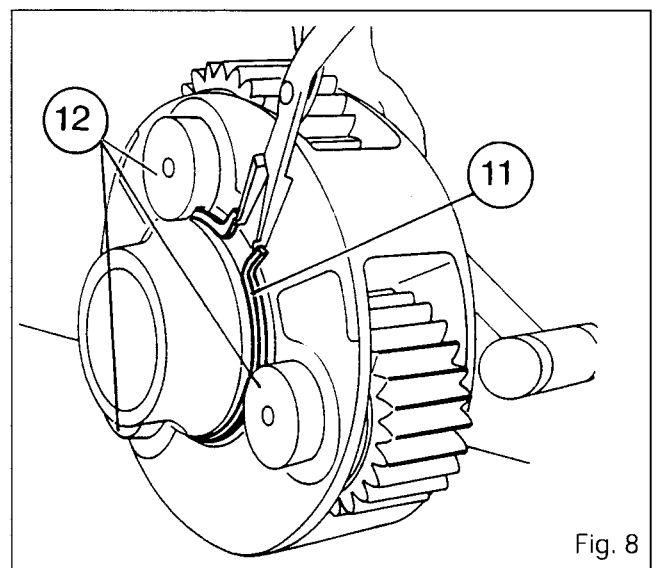
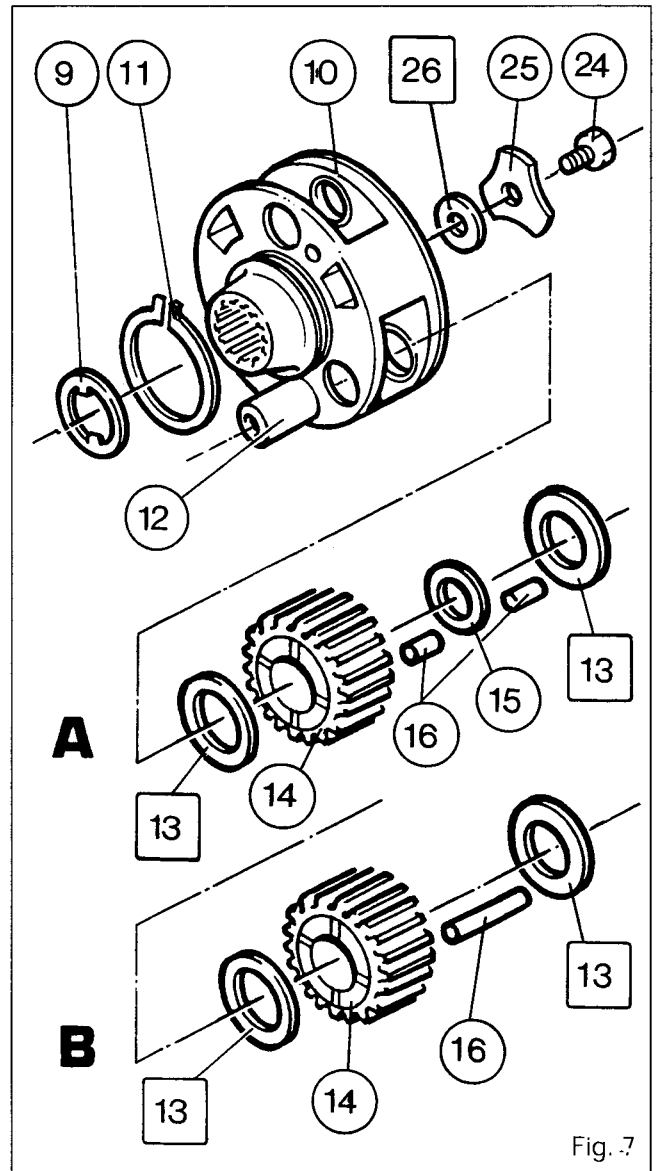





6C01.8

## Rear axle - Trumpet housings

14. Using a set of feeler gauges, determine the thickness of washers [13] to be fitted to obtain an end play of between 0.15 and 0.55 on each planetary gear (Fig.9).
15. Pull out the three pins slightly and fit the shims [13] selected in procedure 14 (Fig.10).
16. Push in the three pins and fit the circlip (11).
17. Open out the circlip (11) (Fig.8).
18. Tap lightly on the three pins to insert the circlip into the groove in the planetary carrier (Fig.11).
19. Check that the spur washer (9) is fitted.
20. Refit the planetary carrier.
21. Fit shims to obtain the required preload (see Section D).
22. Refit the trumpet housing (see Section A).

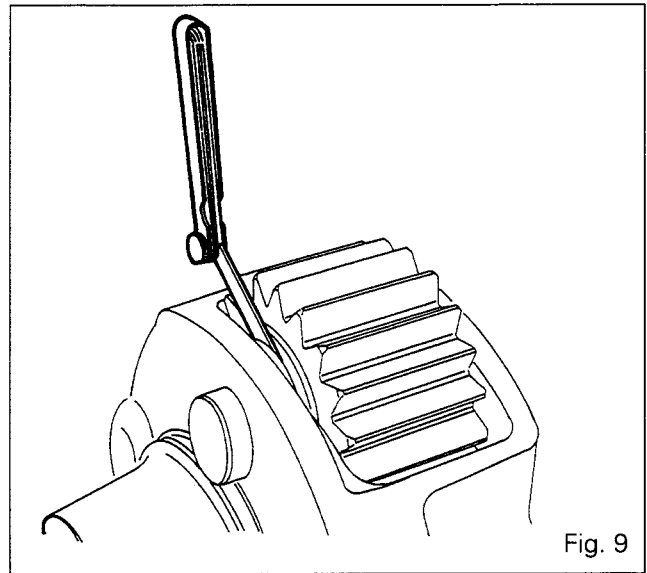

Fig. 9

### C. Bearings and Seals

#### Disassembly

1. Separate the trumpet housing from the centre housing (see Section A).
2. Remove the planetary carrier (see Section B).
3. Remove :
  - the spur washer (9)
  - the bearing cone (8A) (runs free on shaft)
4. Withdraw the shaft (2) from the trumpet housing.
5. Extract the cone (5A).
6. Drive out the triple lip seal /3\
7. Using an extractor, remove:
  - the cup (5)
  - the housing (4) for seal /3\
  - the cup (8)
8. Drive out the seal /7\

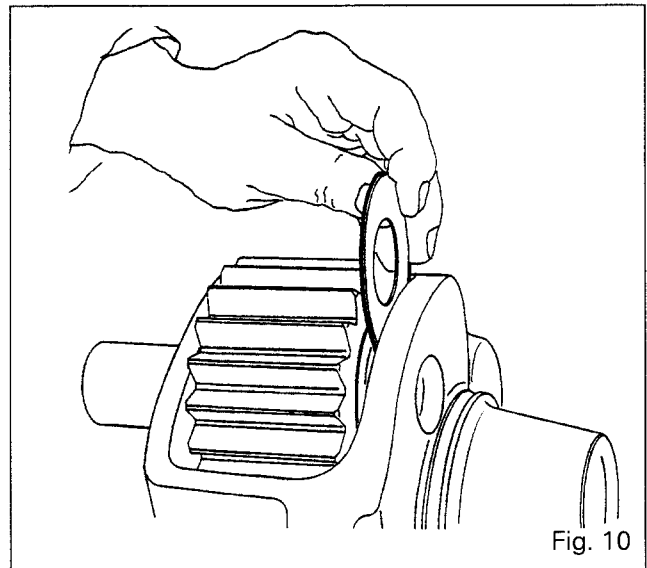

Fig. 10

#### Reassembly

**Note: The planetary ring gear (22) is a tight fit in the trumpet housing (6).**

**It is centred by the three locating dowels (21) (Loctite 638) and tightened by the three bolts (17) to a torque of 79-90 Nm (Loctite 242).**

9. Clean the seal contact surfaces, the cup seats and the cones in the trumpet housing and on the shaft. The seal, cup and cone contact surfaces must be free from burrs and damage.
10. Coat the outside diameter of the seal /7\ with Loctite 542 (metal cage).

**Note: Fit the seal the correct way round.**

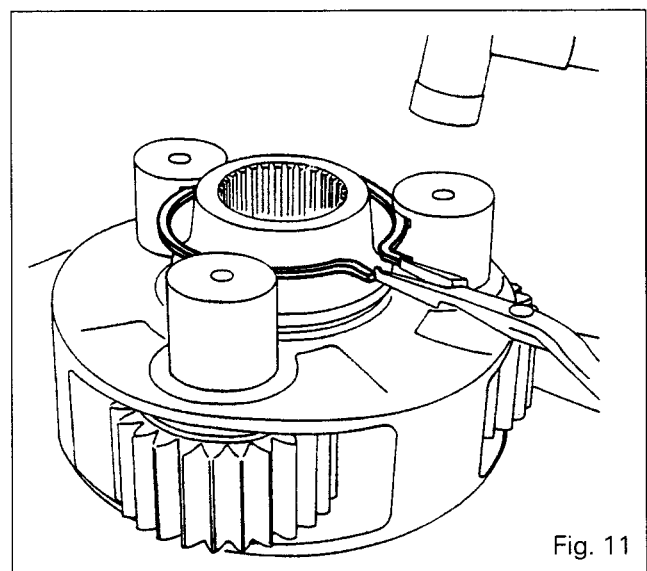

Fig. 11



## Rear axle - Trumpet housings

### 11. Replacement of seal /7\:

#### a) Without replacing the shaft (2)

So that the seal lip is not in the same place on the shaft, press on the seal until it is 4 mm from the shoulder of the cup (8) (Fig.12).

#### b) Replacing the shaft (2)

Position the seal 5 mm from the shoulder of the cup (8) (Fig.13).

12. Lubricate the cups (8) and (5) and press them fully on to the shoulder.
13. Press the housing (4) fully on to the shoulder (Fig.14).
14. Push the triple lip seal /3\ up against the shaft shoulder.

**Note : Ensure that the seal is fitted the correct way round (Fig.14).**

15. Lubricate the shaft (2) and press the cone (5A) against the shoulder.
16. Lightly grease the cone (5A) and the lips of seals /3\ and /7\ (use BP Agricharge or an equivalent-grease).
17. Protect the splines of the shaft (2) and insert it into the trumpet housing.
- Note: The lips of seal /3\ must face outwards.**
18. Remove the protection from the shaft and lightly lubricate the cone (8A).
19. Refit the cone (8A), the washer (9) and the planetary carrier (10).
20. Fit shims to obtain the required preload (see D).
21. Replace the plug (28) by a grease nipple. Partly fill the cavity at the end of the trumpet housing between the cone (5A) and the seal /3\ with BP Agricharge or an equivalent grease. Remove the grease nipple and refit the plug (Fig.14).
22. Refit the trumpet housing (see Section A).

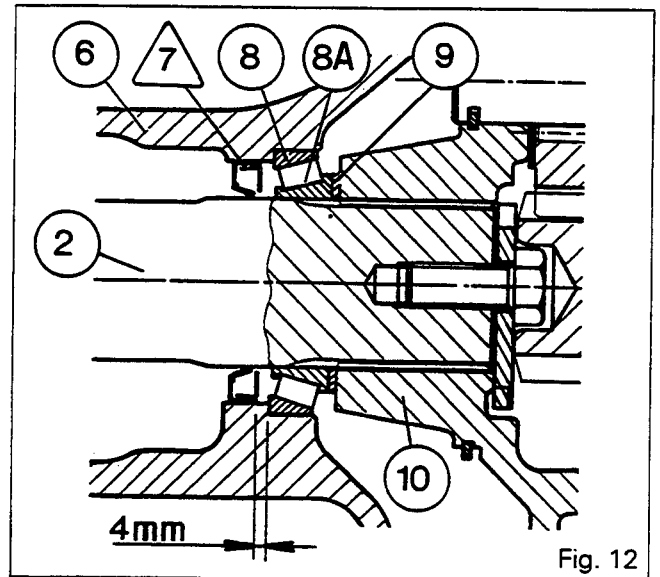

Fig. 12

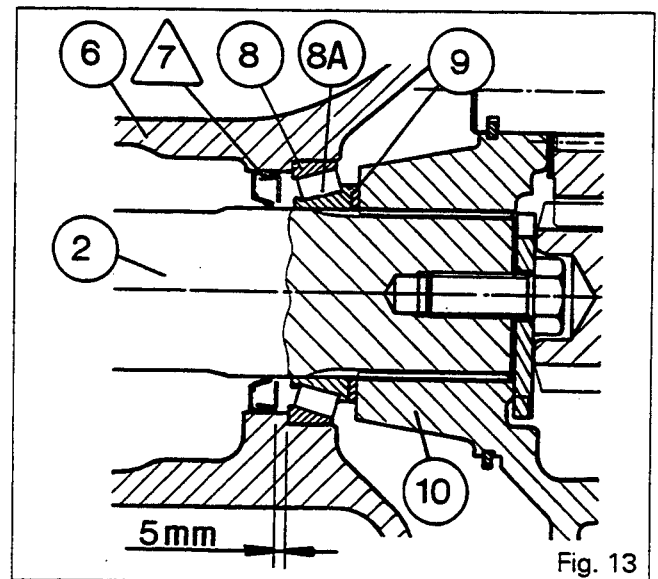

Fig. 13

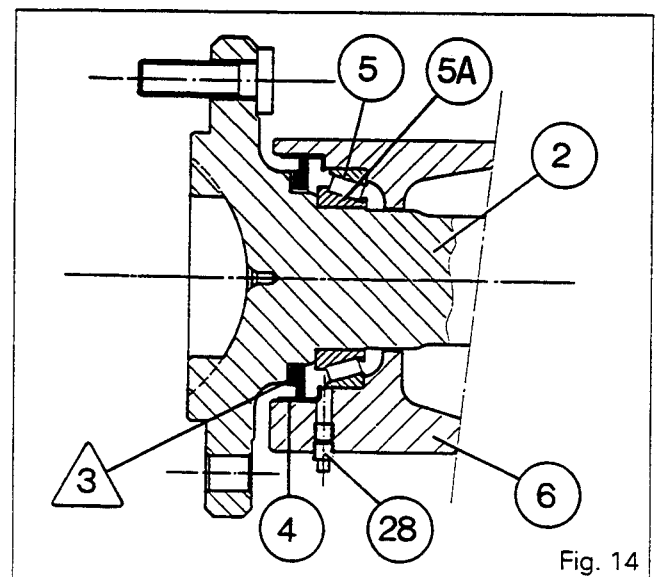

Fig. 14

### D. Axle shaft bearings preload

1. Place the trumpet housing assembly in a vertical position.
2. Remove the bolt (24) and the washer (25).
3. Seat the cones (5A) and (8A) in their cups by turning the trumpet housing on its shaft.



6C01.10

## 6100 SERIES TRACTORS

**Rear axle - Trumpet housings**

4. Fit shims [26] required to provide thickness greater than dimension **X** to obtain end play (Fig.15).
5. Fit the washer (25) and the bolt (24) and tighten to a torque of 270-440 Nm.
6. Using a dial gauge, check the end play by moving the planetary carrier laterally (Fig.16).
7. Remove the bolt (24) and the washer (25).  
On the basis of the reading obtained, remove the number of shims [26] required to obtain a preload of : **P1 = 0.025 to 0.125**
8. Clean the threads at the end of the shaft (2).
9. Refit the washer (25).
10. Clean the bolt (24) and coat it with Loctite 241. Tighten to a torque of 270-440 Nm.

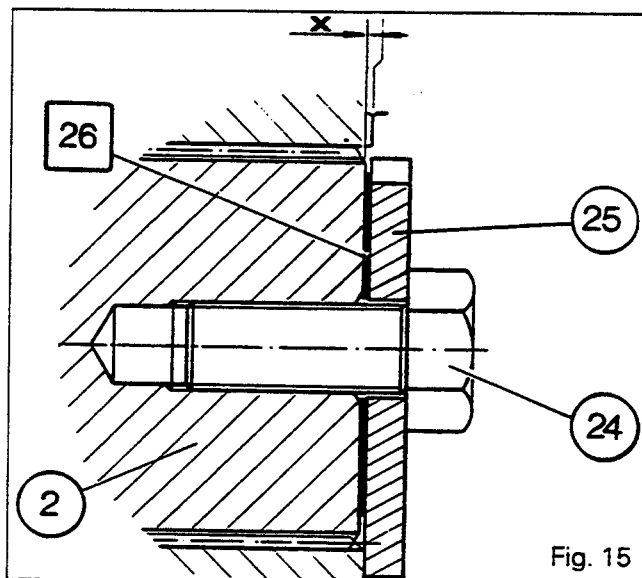
**E. Rear wheel stud replacement**

1. Drive out the damaged stud using a hammer and bronze drift.
2. Clean the marks left by the stud ridges with a paint brush dipped in solvent.
3. Dry with compressed air.
4. Apply a few drops of Loctite 270 to the new stud ridges.
5. Place the new stud in the ridge marks left by the old stud.
6. Make sure that the ridges are properly engaged and then knock the stud head up against the half shaft flange with a bronze mallet.

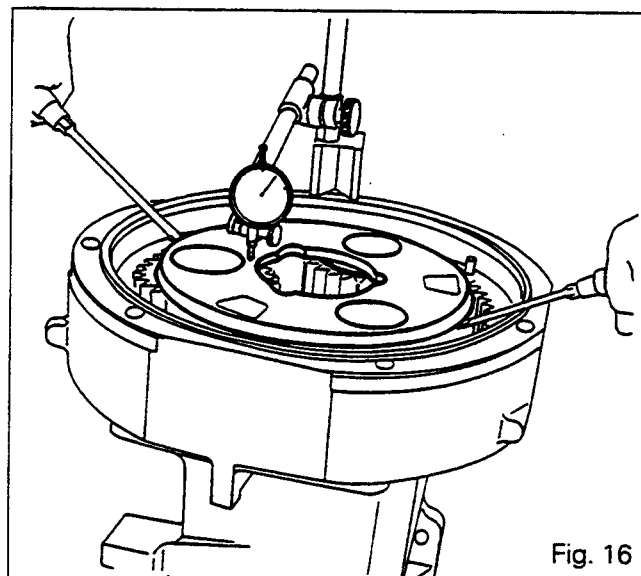



**Rear axle - Heavy Duty trumpets**

*6 C02 Heavy Duty trumpets*

CONTENTS

• <b>General</b> _____	<b>2</b>
<b>A. Trumpet housing assembly</b> _____	<b>5</b>
<b>B. Planetary carrier assembly</b> _____	<b>6</b>
<b>C. Bearings and seals</b> _____	<b>8</b>
<b>D. Axle shaft bearings preload</b> _____	<b>9</b>
<b>E. Wheel stud replacement</b> _____	<b>9</b>



## 6100 SERIES TRACTORS



6C02.2

# Rear axle - Heavy Duty trumpets

## General

### Description

The Heavy Duty trumpets are fitted on 6180 and 6190 tractors. They support the RH and LH axle shafts and house the final reduction units which transmit the drive from the differential assembly.

The two trumpet housings are identical and are fitted on either side of the centre housing.

### Construction

The axle shaft **(2)** is supported by two taper roller bearings **(5)** and **(8)** fitted opposite each other. The unit is sealed on the outside by a triple lip seal **/3\** and on the inside by a single lip seal **/7\**. The final reduction planetary carrier assembly **(21)** fitted with three pinions **(18)** is splined onto the axle shaft **(2)**. Shims **[22]** located at the end of the axle shaft allow the taper roller bearing preload to be adjusted. The shaft **(2)** and the planetary carrier assembly **(21)** are held by the washer **(23)** and the bolt **(24)**. The ring gear **(10)** is a force fit in the trumpet housing. It comprises five locating dowels **(9)** which centre the brake plate **(26)**.

Drive from the differential is transmitted to the final reduction planetary gears through a planetary shaft **(25)** on to which the brake disc **(27)** is splined.

As from serial number E240024, the brake discs are lubricated by a continuous oil flow from the lift valve (open centre) or from the lubrication system (closed centre). (See Section 6F01, General).

### List of parts

- |                                 |                                |
|---------------------------------|--------------------------------|
| <b>(1)</b> Wheel stud           | <b>(14)</b> Spacer             |
| <b>(2)</b> Axle shaft           | <b>(15)</b> Circlip            |
| <b>/3\</b> Triple lip seal      | <b>(16)</b> Planetary gear pin |
| <b>(4)</b> Seal housing         | <b>(17)</b> Thrust washer      |
| <b>(5)</b> Bearing cup          | <b>(18)</b> Planetary gear     |
| <b>(5A)</b> Bearing cone        | <b>(19)</b> Spacer             |
| <b>(6)</b> Trumpet housing      | <b>(20)</b> Needle roller      |
| <b>/7\</b> Seal                 | <b>(21)</b> Planetary carrier  |
| <b>(8)</b> Bearing cup          | <b>[22]</b> Shim(s)            |
| <b>(8A)</b> Bearing cone        | <b>(23)</b> Retaining washer   |
| <b>(9)</b> Locating dowel       | <b>(24)</b> Bolt               |
| <b>(10)</b> Planetary ring gear | <b>(25)</b> Sun wheel          |
| <b>(11)</b> Spur washer         | <b>(26)</b> Brake plate        |
| <b>(12)</b> Plug                | <b>(27)</b> Brake disc         |
| <b>(13)</b> Bolt                | <b>(28)</b> Locating dowel     |
|                                 | <b>(29)</b> Bolt               |



# 6100 SERIES TRACTORS



## Rear axle - Heavy Duty trumpets

6C02.3

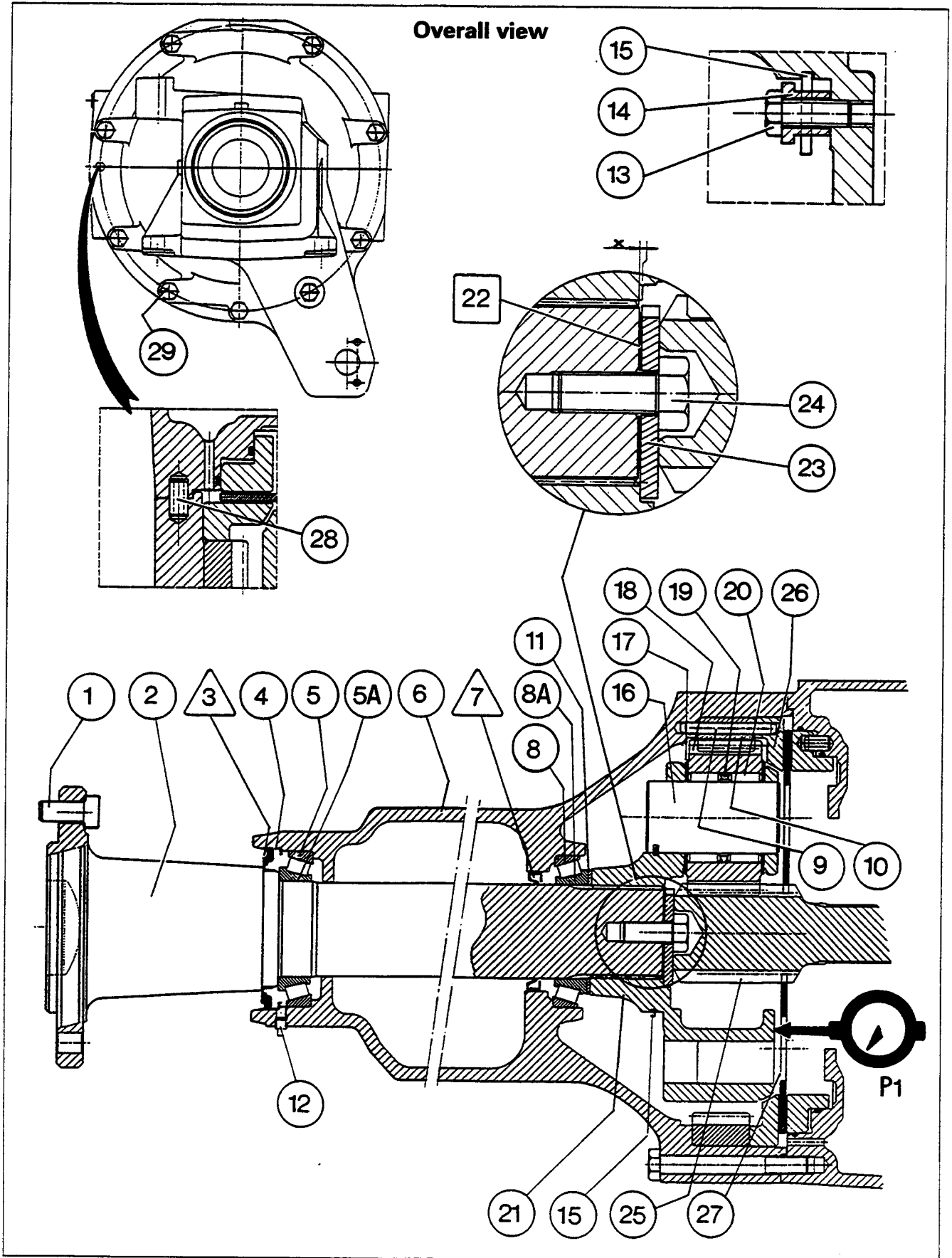



6100 SERIES TRACTORS



6C02.4

Rear axle - Heavy Duty trumpets

Exploded view

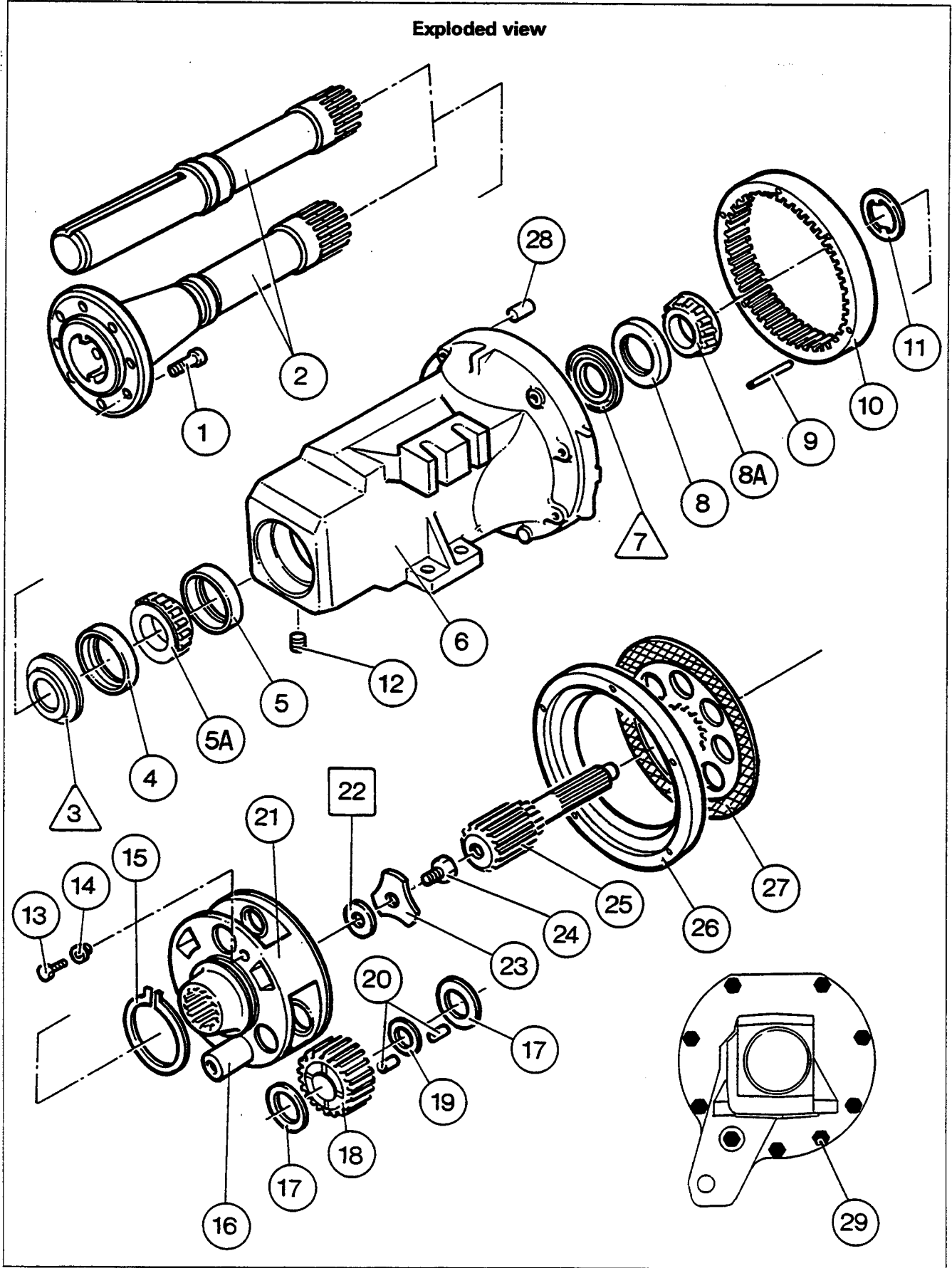



## Rear axle - Heavy Duty trumpets

### A. Trumpet housing assembly

#### Removal

1. Immobilize the tractor. Apply the handbrake. Fit chocks between the frame and the front axle (see 2 A01 Fig 2).
2. Drain the rear axle only.
3. Using a trolley jack, raise the side of the tractor involved.
4. Support the tractor with an axle stand.
5. Remove the wheel.
6. Remove the stabilizer bracket
7. Disconnect the draft control sensor harness (without disconnecting the harness).  
As from serial number E240024 (open centre), disconnect the brake lubricating hose (1) or pipe (11) (depending on the side concerned). (Fig. 1B).
8. Remove the cab attaching bolts (A) with the nuts (Fig.1).
9. Raise the cab slightly to lift the support spacer (B) clear (Fig.1).
- Important: Check the space between the bonnet and the windscreen.**
10. Position a suitable support on a trolley jack under the trumpet housing.
11. For the LH trumpet housing disconnect the lift hydraulics valve supply hose (plug the ends).
12. Unscrew the attaching bolts (29).
13. Separate the trumpet housing from the rear axle housing.
14. Remove :
  - . the brake disc (27)
  - . the planetary shaft (25)
  - . the locating dowel (28)
- Note: Before serial number E240024, to prevent the brake piston (C) from coming out of the housing, it is recommended that two wide washers and two bolts be fitted diametrically opposite each other to hold it in place (Fig.2).**
15. Remove the brake plate (26).

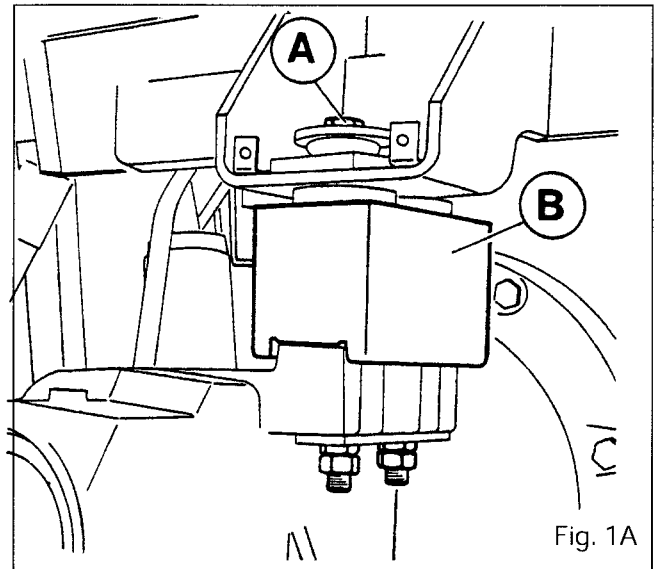

Fig. 1A

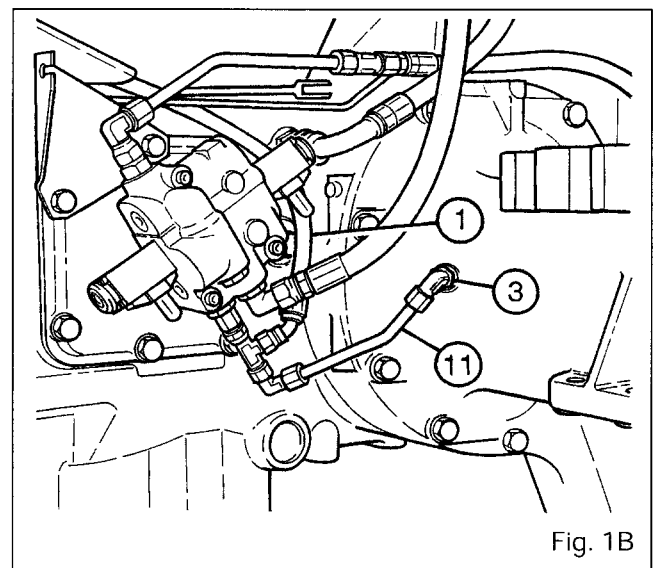

Fig. 1B

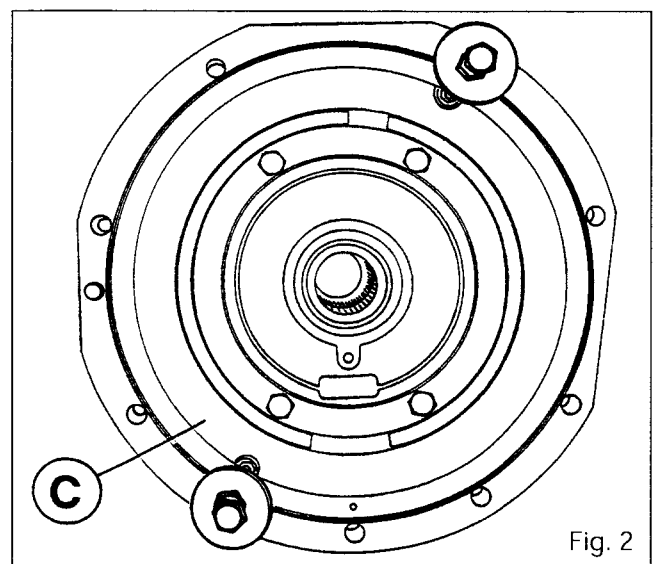

Fig. 2





6C02.6

## Rear axle - Heavy Duty trumpets

### Refitment

16. Clean the mating faces of the centre housing and the trumpet housing with a non-greasy solvent.
17. Apply a bead of oil resistant silicone (Silicomex type) to the inner edge of the centre housing (Fig.3).
18. Check that the disk (27) slides freely on the sun gear (25) (Fig.4).
19. Refit the locating dowel (28), the planetary shaft (25) and the brake disc (27).
20. Screw two dowel pins into diametrically opposite positions on the centre housing.
21. Refit the brake plate (26) in the trumpet housing.  
**NOTE: To retain the plate, apply three spots of "Amber Technical" or equivalent grease to the surface of the ring gear (10).**
22. Fit the trumpet housing to the centre housing.  
**Note: Turn the shaft (2) to engage the planetary shaft (25) in the planetary gears (18)**
23. Clean the bolts (32) and coat them with Plastex, Hylomar or an equivalent gasket sealant.
24. Fit and tighten the bolts (29) to a torque of 170 - 210 Nm.
25. Carry out procedures 9 to 11 in reverse.
26. Refit the cab attaching bolts with the nuts and locknuts to a torque of:  
Nut : 27-35 Nm  
Locknut : 13-20 Nm (with Loctite 270)
27. Reinstall the draught control sensor after lightly smearing it with Loctite Anti-seize or equivalent. Reconnect the hose (1) or pipe (11) on the restrictor union (3) (Fig. 1B).
28. Carry out procedure 3 in reverse.
29. Reinstall the wheel. Tighten to a torque of 400 to 450 Nm and carry out procedure 3 in reverse.
30. Remove the axle stand.
31. Carry out procedures 1 and 2 in reverse.
32. Test the hydraulic lift and brake circuits.
33. **Check for leaks :**
  - between the trumpet housing and the rear axle housing,
  - from the lift system valve supply hose,
  - from the brake lubrication pipes.

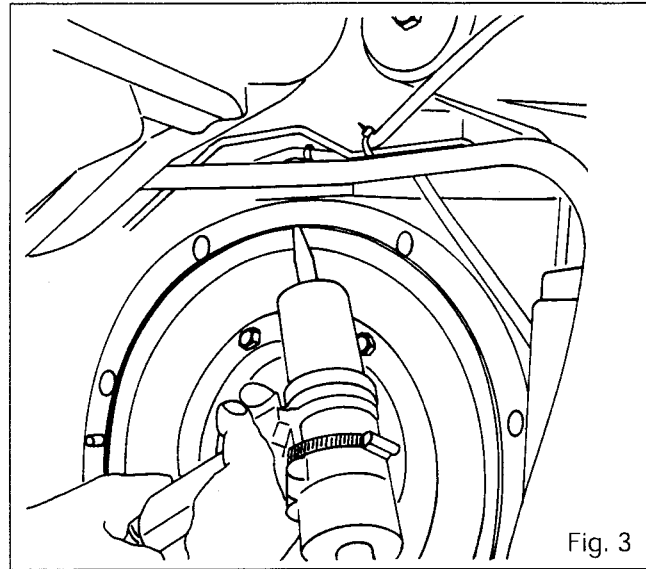

Fig. 3

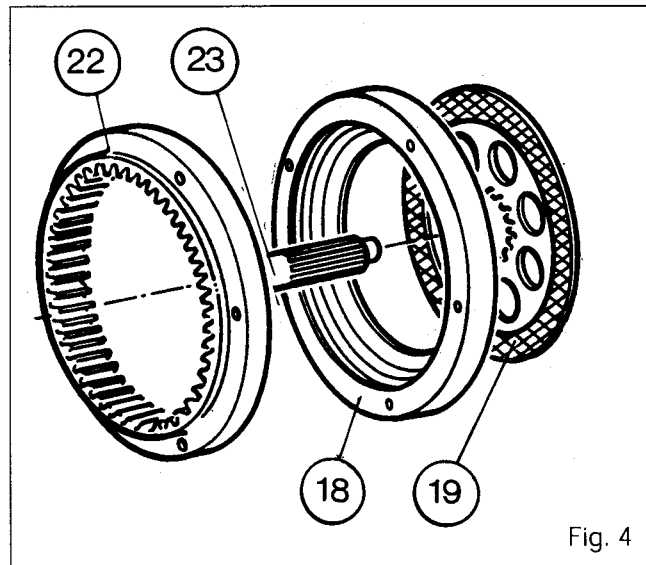

Fig. 4

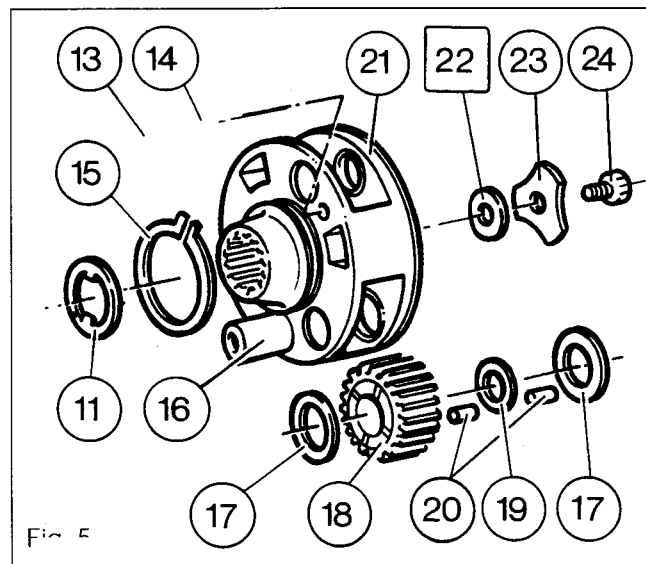

Fig. 5

## B. Planetary carrier assembly

### Disassembly

1. Remove the trumpet housing (see Section A).
2. Remove the bolt (24).
3. Remove the retaining washer (23) and the shim(s) [22] (Fig.5).



## Rear axle - Heavy Duty trumpets

6C02.7

4. Remove the planetary carrier assembly (21).
5. Remove the bolt (13) and the spacer (14).
6. Open out the circlip (15) (Fig.6).
7. Using a copper tipped mallet, tap lightly on the three pins (16) (Fig.6).
8. Remove the three pins (16) and the circlip (15).
9. Remove the three planetary gears (18), the needle rollers (20), the spacers (19) and the thrust washers (17).

### Reassembly

10. Clean the planetary carrier (21), the pins (16) and the planetary gears (18). Check the condition of the parts.
11. Coat the needle rollers (20) with "Amber Technical" or an equivalent grease. Into each planetary gear (18) insert two rows of needle rollers separated by a spacer (19).  
**Note: Each planetary gear has 56 needle rollers.**
12. Fit the planetary gears (18) and the thrust washers (17).
13. Fit three pins (16) with the circlip (15) (Fig.7).
14. Open out the circlip (15) (Fig.6).
15. Tap lightly on the three pins to insert the circlip (15) into the planetary carrier groove (Fig.7).
16. Position one end of the circlip in contact with the pin (16) (Fig.8)
17. Clean the threads of the bolt (13). Fit the spacer (14). Coat the bolt (13) with Loctite 270 before fitting. Tighten to a torque of 34 - 50 Nm (Fig.8).
18. Check that the spur washer (11) is fitted.
19. Refit the planetary carrier.
20. Fit shims to obtain the required preload (see Section D).
21. Refit the trumpet housing (see Section A).

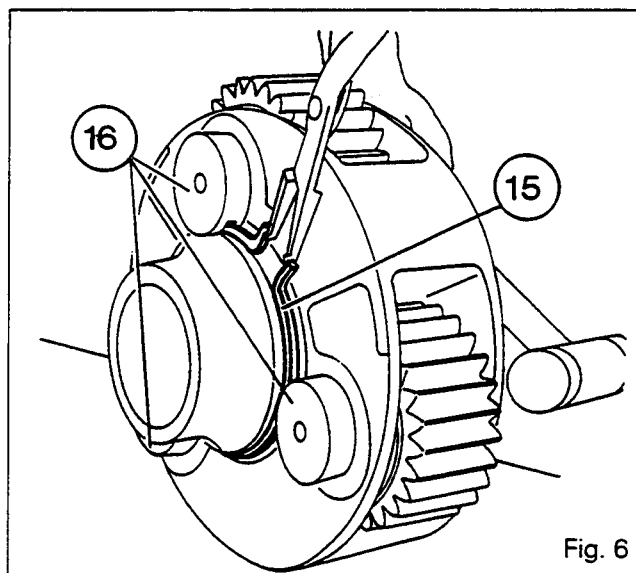

Fig. 6

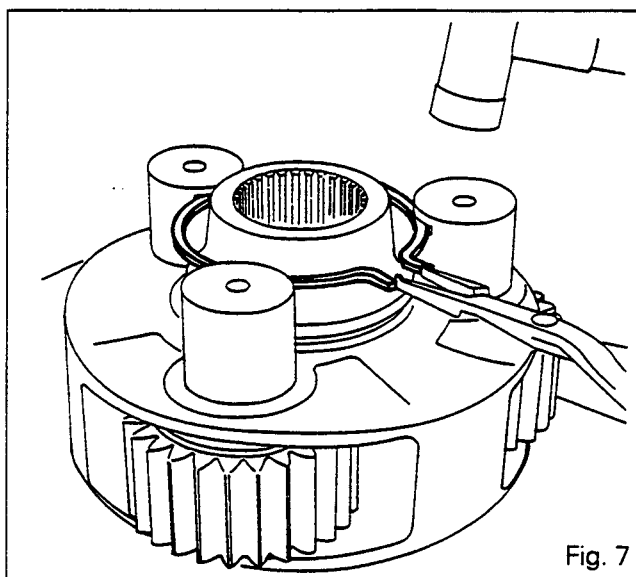

Fig. 7

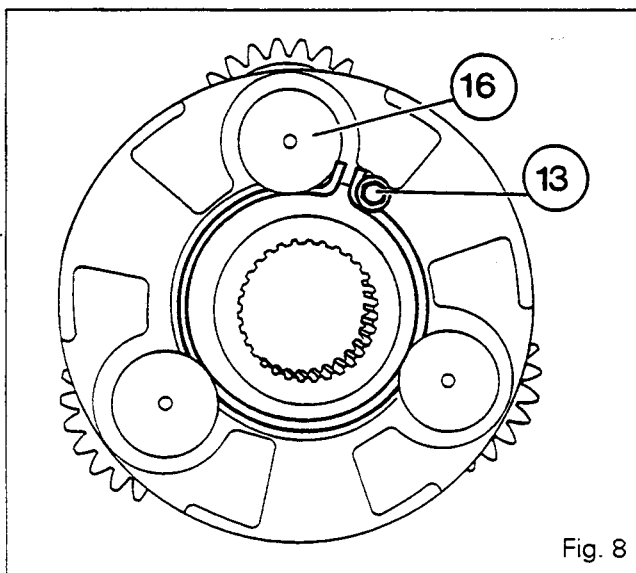

Fig. 8



6C02.8

# Rear axle - Heavy Duty trumpets

## C. Bearings and seals

### Disassembly

1. Separate the trumpet housing from the centre housing (see Section A).
2. Remove the planetary carrier (see Section B).
3. Remove :
  - the spur washer (11) (Fig. 9)
  - the bearing cone (8A) (runs free on shaft)
4. Withdraw the shaft (2) from the trumpet housing.
5. Extract the cone (5A).
6. Drive out the triple lip seal /3\.
7. Using an extractor, remove:
  - the cup (5)
  - the housing (4) for seal /3\
  - the cup (8)
8. Drive out the seal /7\.

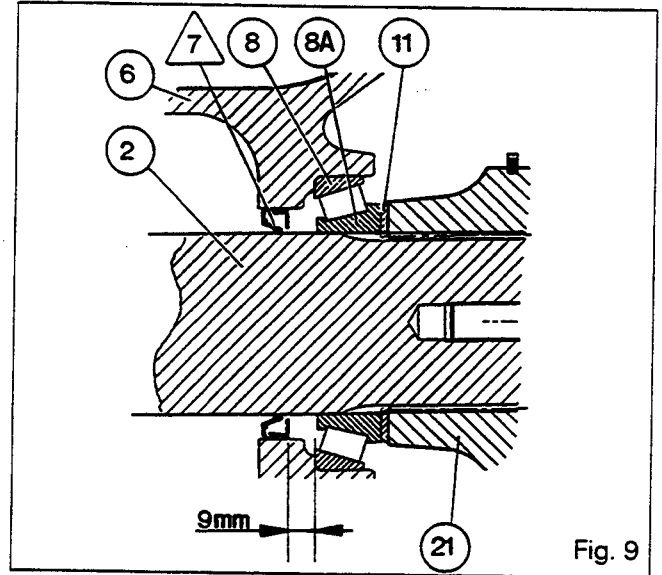

Fig. 9

### Reassembly

9. Clean the seal contact surfaces, the cup seats and the cones in the trumpet housing and on the shaft. The seal, cup and cone contact surfaces must be free from burrs and damage.
10. Coat the outside diameter of the seal /7\ with Loctite 542.
- Note: Fit the seal the correct way round.**
11. Replacement of seal /7\
  - a) Without replacing the shaft (2)
 

So that the seal lip is not in the same place on the shaft, press on the seal until it is 9 mm from the shoulder of the cup (Fig 9).
  - b) Replacing the shaft (2)
 

Position the seal 8 mm from the shoulder of the cup (Fig.10).
12. Lubricate the cups (8) and (5) and press them fully on to the shoulder.
13. Press the housing (4) to within 20 mm of the trumpet housing (Fig.11).
14. Push the triple lip seal /3\ up against the shaft shoulder.
 

**Note: Ensure that the seal is fitted the correct way round (Fig.11).**
15. Lubricate the shaft (2) and press the cone (5A) against the shoulder.
16. Lightly grease the cone (5A), the lips of seals /3\ and /7\ (use BP Agricharge or an equivalent grease).

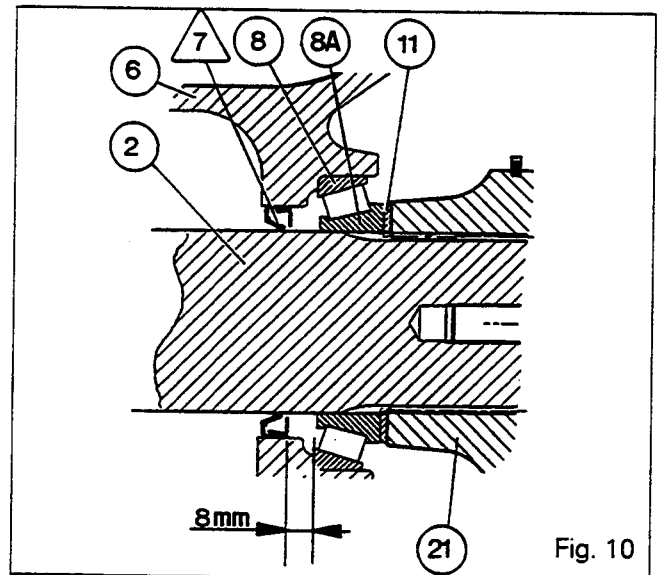

Fig. 10

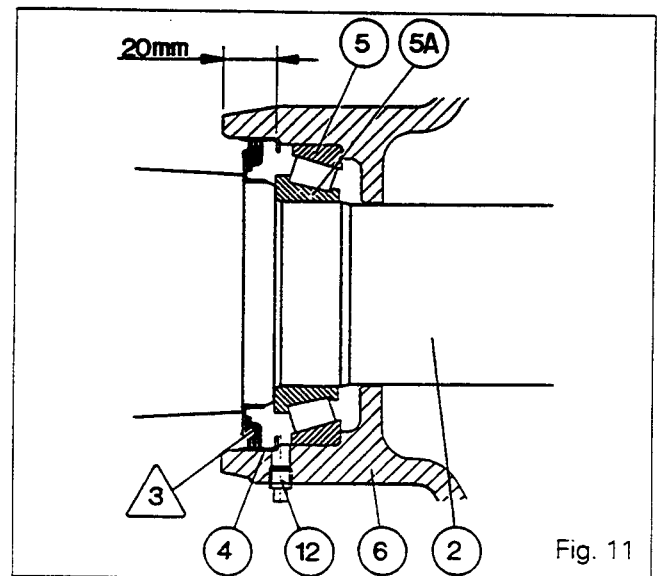

Fig. 11



## Rear axle - Heavy Duty trumpets

17. Protect the splines of the shaft (2) and insert it into the trumpet housing.

**Note: The lips of the seal /3\ must face outwards.**

18. Remove the protection from the shaft and lightly lubricate the cone (8A).

19. Carry out procedures 2 and 3 in reverse.

20. Fit shims to obtain the required preload (see D).

21. Replace the plug (12) by a grease nipple. Partly fill the cavity at the end of the trumpet housing between the cone (5A) and the seal /3\ with BP Agricharge or an equivalent grease. Remove the grease nipple and refit the plug (Fig.11).

22. Refit the trumpet housing (see Section A).

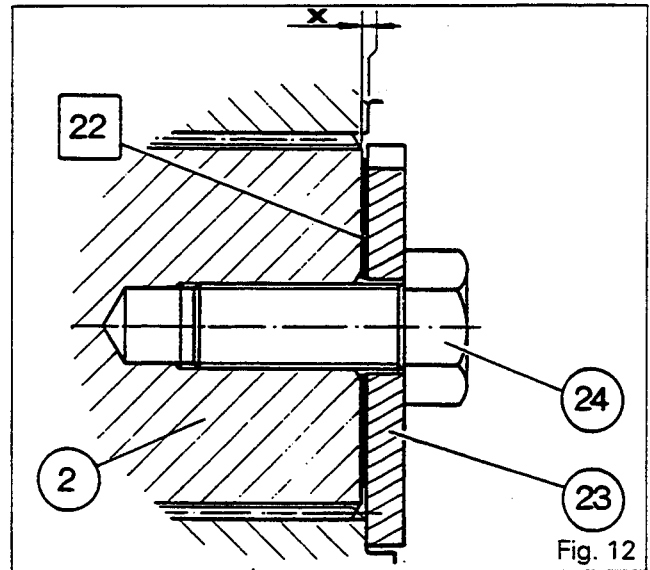

Fig. 12

### D . Axle shaft bearings preload

1. Place the trumpet housing assembly in a vertical position.
2. Remove the bolt (24) and the washer (23).
3. Seat the cones (5A) and (8A) in their cups by turning the trumpet housing on its shaft.
4. Fit shims [22] required to provide thickness greater than dimension X to obtain end play (Fig.12).
5. Fit the washer (23) and the bolt (24) and tighten to a torque of 270 - 440 Nm.
6. Using a dial gauge, check the end play by moving the planetary carrier laterally (Fig.13).
7. Remove the bolt (24) and the washer (23).  
On the basis of the reading obtained, remove the number of shims [22] required to obtain a preload of :  $P1 = 0.025$  to  $0.125$
8. Clean the threads at the end of the shaft (2).
9. Refit the washer (23).
10. Clean the bolt (24) and coat it with Loctite 241.  
Tighten to a torque of 270 - 440 Nm.

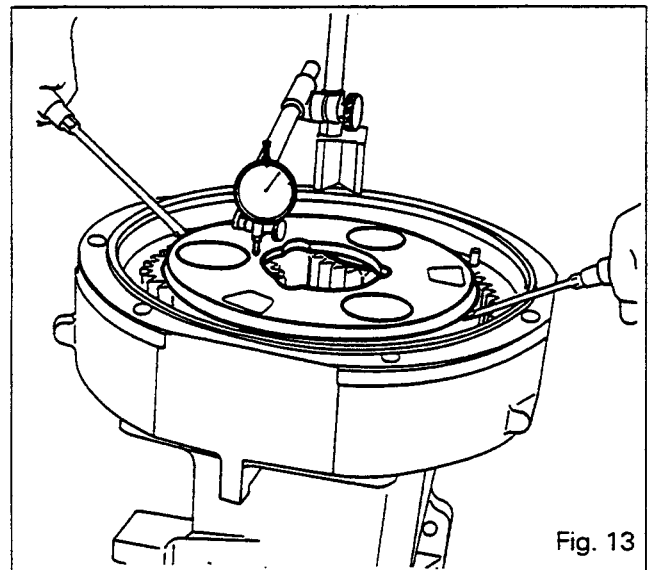

Fig. 13

### E . Rear wheel stud replacement

1. Drive out the damaged stud using a hammer and bronze drift.
2. Clean the marks left by the stud ridges with a paint brush dipped in solvent.
3. Dry with compressed air.
4. Apply a few drops of Loctite 270 to the new stud ridges.
5. Place the new stud in the ridge marks left by the old stud.
6. Make sure that the ridges are properly engaged and then knock the stud head up against the half shaft flange with a bronze mallet.





6100 SERIES TRACTORS



**Rear Axle - Handbrake**

6D01.1

6 D01 Handbrake

CONTENTS

- <b>General</b> _____	2
- <b>Operation</b> _____	2
<b>A. Disassembly</b> _____	5
<b>B. Reassembly</b> _____	7
<b>C. Fitting and adjustment of control</b> _____	9
<b>D. Buzzer wiring diagram</b> _____	10



6D01.2

---

**6100 SERIES TRACTORS**

---

**Rear Axle - Handbrake**

---

**General**

---

The handbrake assembly is fitted on the bevel drive pinion. It consists of a mechanism placed between two friction discs which are driven by the bevel drive pinion via splines.

The mechanism comprises two cast iron plates held by springs and separated by balls housed in cams.

---

**Operation**

---

When the handbrake lever in the cab is pulled, the cam (14) is moved via the pin (20). The cam pushes the actuator lever (13) which causes the plates of the mechanism (31) to rotate and move apart. The discs (30) are thus compressed between the moving plates, the closing plate (24) and the supporting plate (29), preventing the bevel drive pinion from rotating.

When the handbrake lever is released, the spring (17) moves the cam (14) to the rest position and the mechanism is closed by its springs.

**List of parts**

- (1) Circlip
- (2) Pinion
- (3) Stud
- (4) Nut
- (5) Plate
- (6) Pin
- (7) Clevis
- (8) Pin
- (9) Cotter pin
- (10) Left cover
- (11) Plug
- (12) Seal Ring
- (13) Actuator lever
- (14) Cam
- (15) Circlip
- (16) Finger
- (17) Spring
- (18) Dowel
- (19) Seal ring
- (20) Control shaft
- (21) Retainer ring
- (22) Washer
- (23) Finger
- (24) Closing plate
- (25) Screw
- (26) Bevel drive pinion
- (27) Shim(s)
- (28) Screw
- (29) Supporting plate
- (30) Discs
- (31) Mechanism



6100 SERIES TRACTORS



Rear Axle - Handbrake

6D01.3

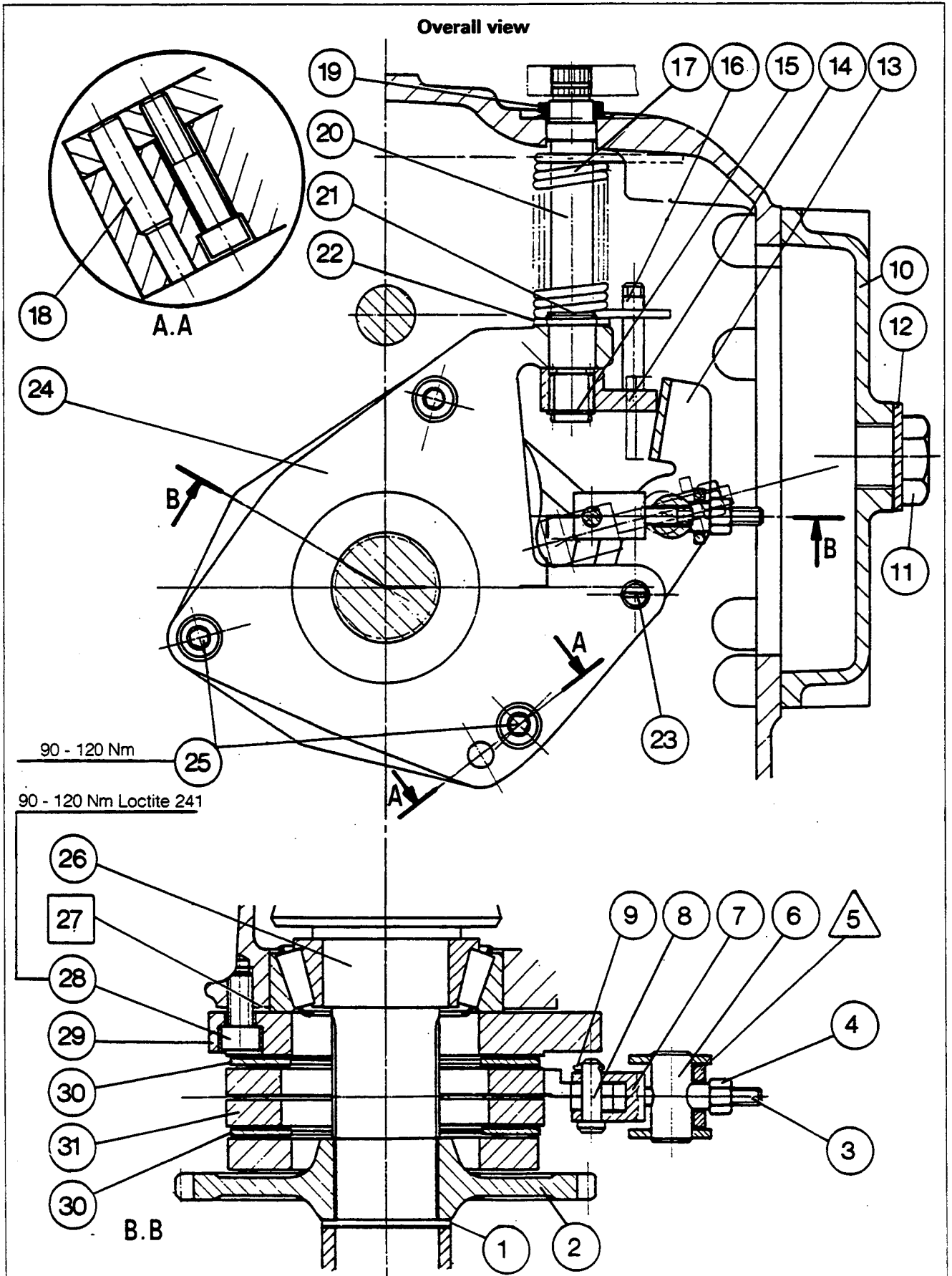





6100 SERIES TRACTORS



6D01.4

Rear Axle - Handbrake

Overall view

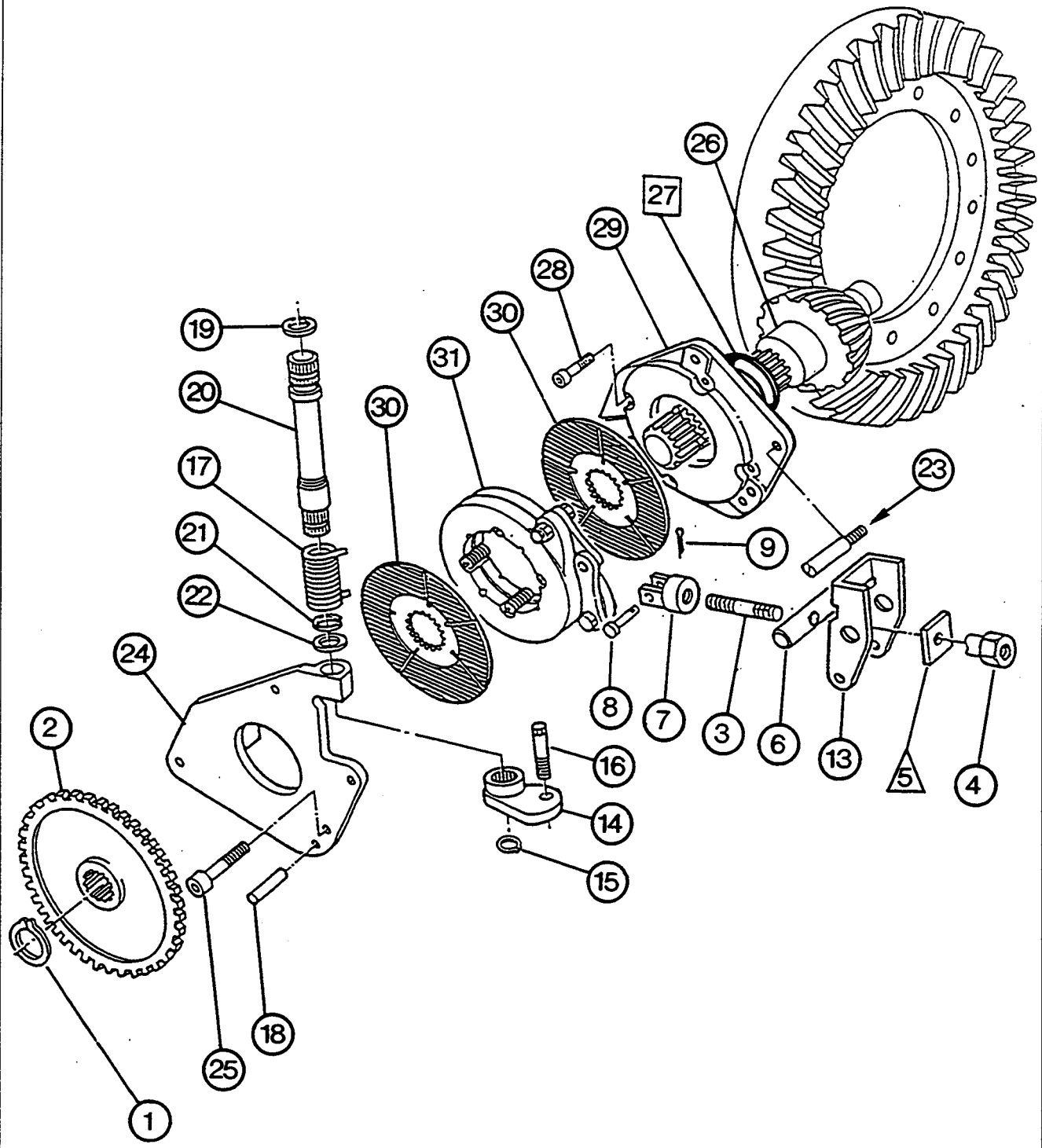



## Rear Axle - Handbrake

### A. Disassembly

1. Drain the rear axle housing.
2. Block :
  - the front wheels of the tractor
  - between the engine frame and the front axle (Fig. 1).
3. Raise the tractor with a jack.
4. Place props in position.
5. Remove the rear wheels.
6. Remove the right-hand hydraulic cover. Carry out operations 2 to 14, section 9 I01.
7. Remove the left-hand cover. Carry out operations 2 to 6, section 9 I02.

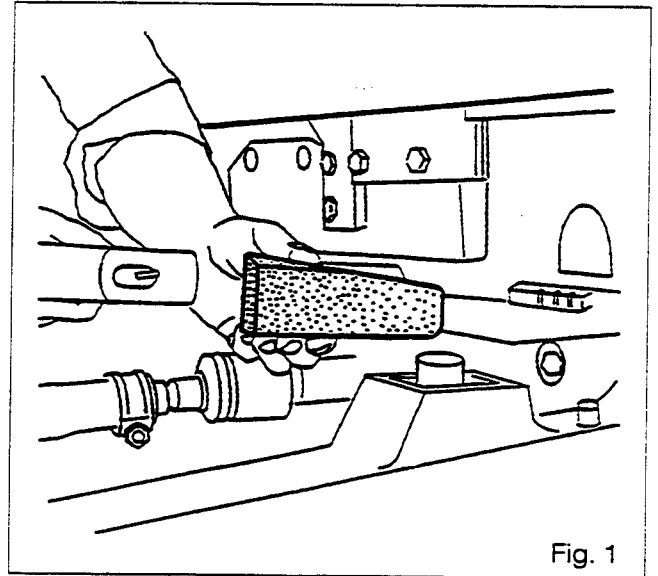

Fig. 1

#### Tractors without creeper gears

8. Drive out the double pins (2) and (4) of the coupling sleeves (1) and (5). Slide the sleeves towards each other on the pin (3). Remove the pin and sleeve assembly (Fig. 2).  
On 4RM tractors  
If the double pins are not accessible, carry out operations 9 to 12, section 5 D01.A.
9. Remove the circlip (1).
10. Remove the pinion (2) (if fitted).

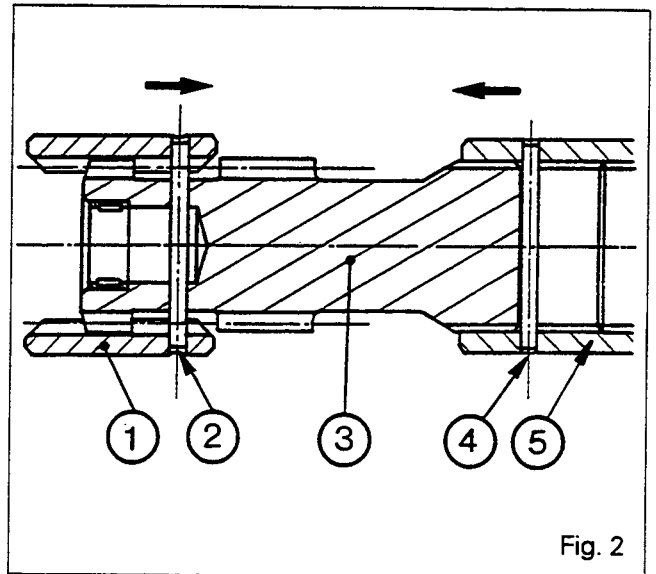

Fig. 2

#### Tractors with creeper gears

11. Remove the creeper gears control fork and the sleeve assembly (linking pin and coupler).  
Carry out operations 3 to 8, section 5 D01.A.
12. Carry out operations 13 to 16, section 5 D01.A.
13. Remove the circlip (1).
14. Remove the pinion (2) (if fitted).

#### Tractors with or without creeper gears

**Note:** Lift the cab, carry out operations 2 and 3, section 6 B01. Examine the space between the hood and the windscreen (if the space is inadequate, remove the sheetmetal).

15. Disconnect the cable (3). Take out the split pin (1) and remove the control arm (2) (Fig. 3).
16. Remove the seal (19).
17. Release the spring (17) using pliers.
18. Undo the nut to release the actuator lever (13) of the cam (14).
19. Remove the circlip (15).
20. Remove the cam (14) with the finger (16).
21. Remove the screws (25).

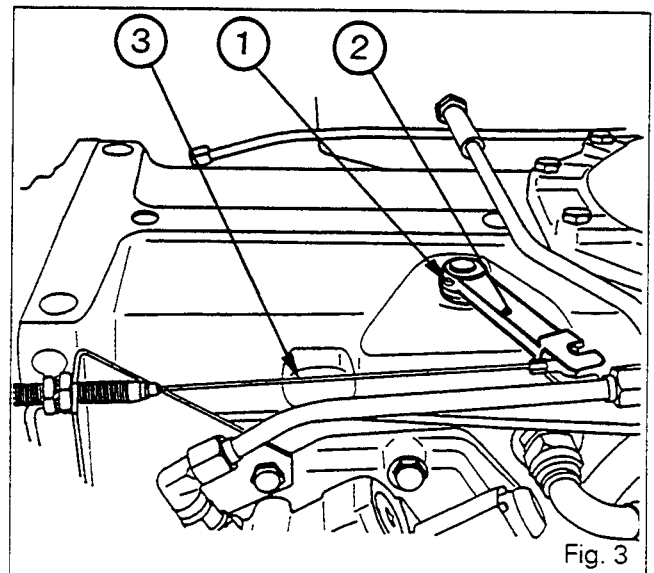

Fig. 3



6D01.6

# 6100 SERIES TRACTORS



## Rear Axle - Handbrake

- 22. Remove the closing plate (24) and the control shaft (20).

**Note:** Keep the mechanism (31) and the brake discs (30) towards the rear. Withdraw the closing plate (24) (Fig. 4), inclining it in order to disengage it from the dowel (18), the finger (23) and the bevel drive pinion (26) and to release the shaft (20) from the housing.

- 23. Remove the spring (17) and the washer (22).
- 24. Remove the retainer ring (21) (if necessary) on the control shaft (20).
- 25. Remove the discs (30) and the mechanism (31).

### In case of replacement of mechanism

- 26. Undo the nut (4), remove the plate (5) and the pin (6).
- 27. Remove the split pin (9), take out the pin (8) and the clevis (7).

**Note:** The stud (3) is smeared with Loctite 270 and locked in the clevis (7).

### If replacement of the supporting plate (29) is unavoidable

- 28. Remove two diametrically opposed screws (28) and screw in two guide studs (A) (Fig. 5). The purpose of this is to hold the shims [27] (Fig. 6).
- 29. Unscrew the two remaining screws.
- 30. Remove the supporting plate.

**Note:** Check that the shims have all remained on the housing.

The finger (16) smeared with Loctite 241 is screwed into the cam (14). The finger (23) smeared with Loctite 241 is screwed into the supporting plate (29).

The dowel (18) is pushed fully home on the shoulder of the closing plate (24).

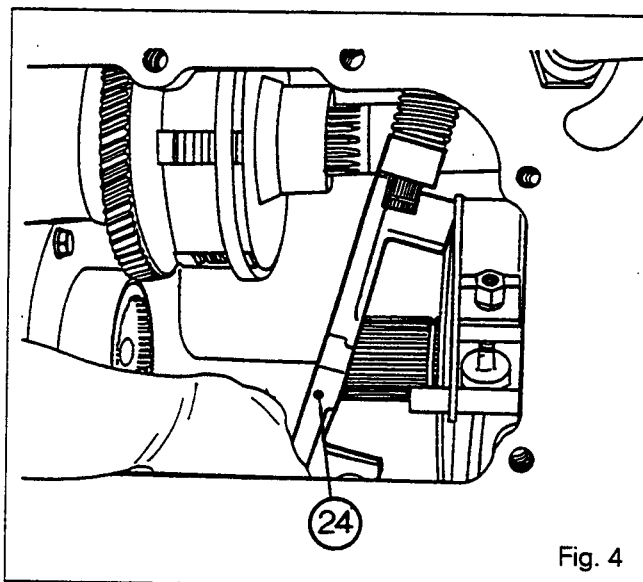

Fig. 4

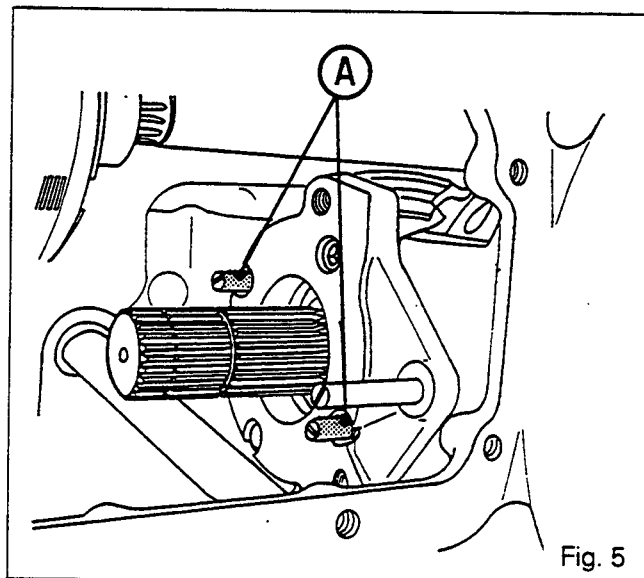

Fig. 5

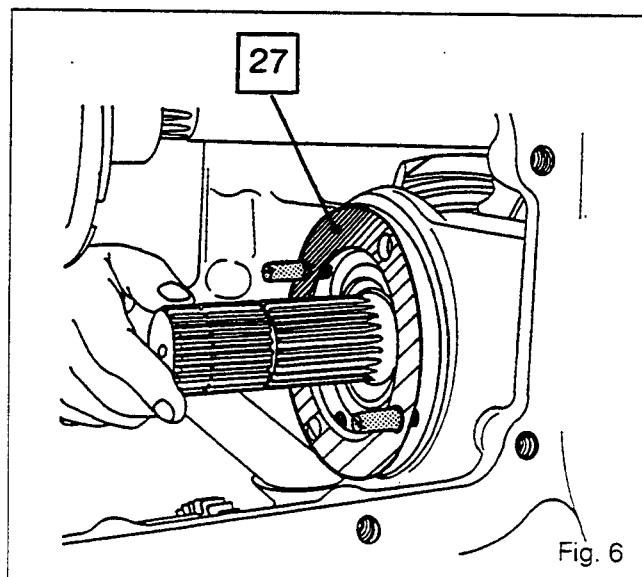

Fig. 6



## Rear Axle - Handbrake

### B. Reassembly

31. Clean and check the parts. Replace any which are defective.

#### In case of replacement of supporting plate (29)

32. Refit the plate.
33. Smear two screws (28) with Loctite 241 then tighten to a torque of 90 - 120 Nm.
34. Remove the two guide studs.
35. Smear the other two screws (28) with Loctite 241 then tighten to a torque of 90 - 120 Nm.

#### In case of replacement of mechanism

36. Refit the clevis (7) prepared with the stud (3) and the pin (8). Replace the split pin (9).
37. Fit the lever (13) with its pin (6) on the stud (3) of the clevis.
38. Refit the plate /5\, tighten the nut (4).  
**Note: The plate /5\ is rectangular. It must be positioned horizontally, lengthwise, on the pin (6) in the lever (13) to be correct (Fig. 7).**
39. Replace the discs (30), placing the mechanism (31) between them.  
**Note: Fit the lever (13) on the finger (23). Check that the discs slide freely on the bevel drive pinion (26).**
40. Place the retainer ring (21) (if removed) on the shaft (20).
41. Fit the shaft (20) in the closing plate (24) with the washer (22) and the spring (17).
42. Reverse operation 22.
43. Check that the discs (30) and the mechanism (31) are correctly positioned.
44. Fit and tighten the screws (25) to a torque of 90 - 120 Nm.
45. Fit the cam (14) with its finger (16).
46. Fit the circlip (15). Replace the spring (17), positioning its ends E as indicated in Fig. 8.
47. Fit the seal (19) supported by the housing (Fig. 9).

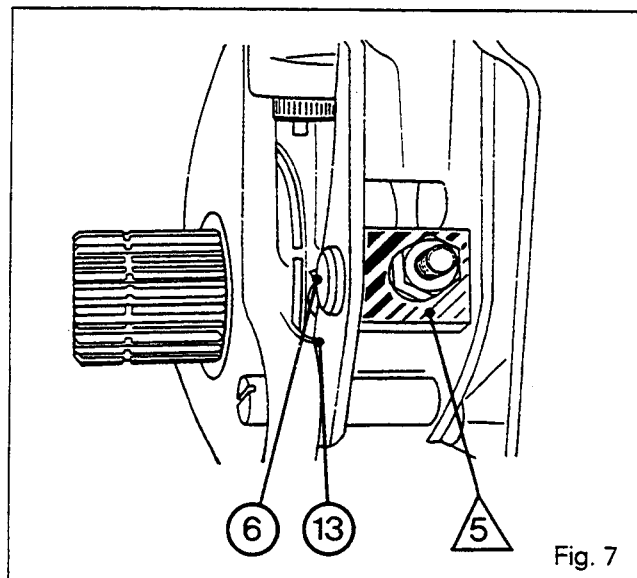

Fig. 7

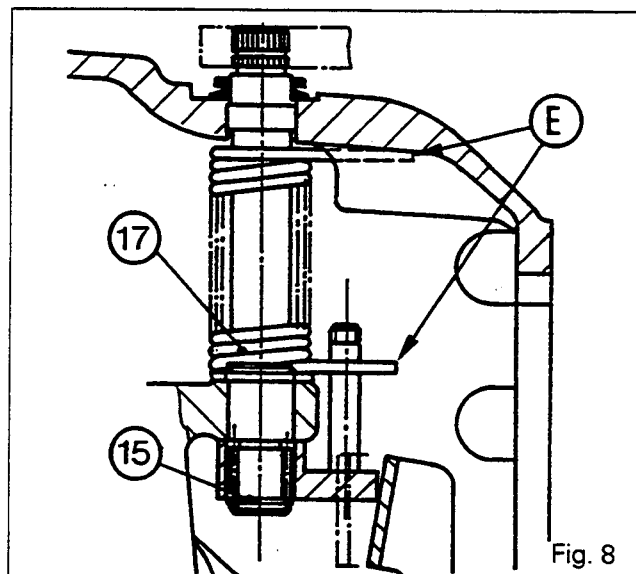

Fig. 8

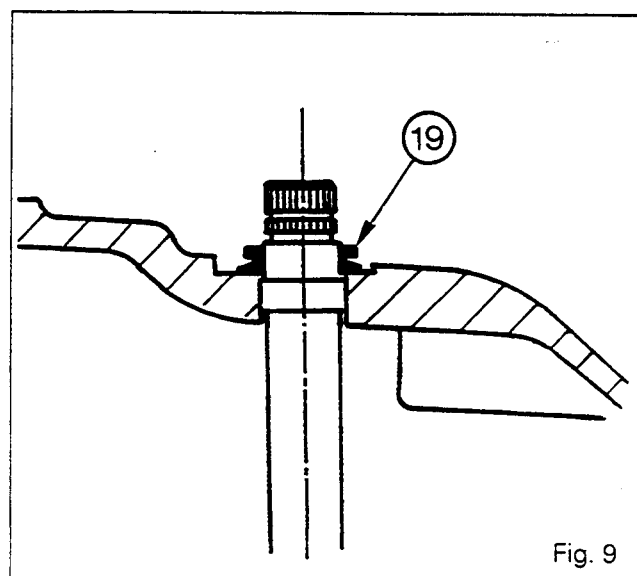

Fig. 9



6D01.8

## 6100 SERIES TRACTORS



## Rear Axle - Handbrake

**Tractors with creeper gears**

48. Refit the pinion (2) (if fitted).
49. Position the circlip (1).
50. Refit the sleeve assembly (linking pin and coupler) and the creeper gears control fork. Carry out operations 22 to 31, section 5 D01.A.

**Note: If necessary reverse operations 9 to 12 (4 RM), section 5 D01.A.**

**Tractors without creeper gears**

51. Refit the pinion (2) (if fitted).
52. Position the circlip (1).
53. Refit the sleeve assembly (linking pin and coupler) and the creeper gears control fork. Carry out operations 44 and 45, section 7 D01.

**Note: If necessary reverse operations 9 to 12 (4 RM), section 5 D01.A.**

**Tractors with or without creeper gears**

54. Refit the left cover. Carry out operations 8 to 17, section 9 I02.
55. Position the lever (2) (Fig. 10) of the cam (14) in contact with the lever (13) so as to obtain a distance of 315 mm  $\pm$  12 between the cable fastening axis and the support (3). Fit the cotter pin (1) (Fig. 10).
56. Adjust the mechanism (31) with the adjusting nut, so that the cam displacement, from rest position to maximum position, is 60° (Fig. 11).

**Note: Access to the adjusting nut (4) is via the aperture of the plug (11) on the left cover (10) (Fig. 12).**

57. Reconnect the control
58. Adjust the handbrake control.  
Carry out operations 73 to 75.  
Remove the blocks between the cab supports and the trumpet housings. Fit the washers. Position the cab. Tighten the nuts to a torque of 27 - 35 Nm and the lock-nuts, smeared with Loctite 270, to 13 - 20 Nm. Refasten the protecting panels.
59. Refit the right-hand hydraulic cover. Carry out operations 15 to 27, section 9 I01.
60. Raise the tractor with a jack.
61. Refit the wheels.
62. Remove the props and the jack.
63. Tighten the wheel nuts to a torque of 400 - 450 Nm.
64. Remove the blocks at the front of the tractor and between the engine frame and the front axle.

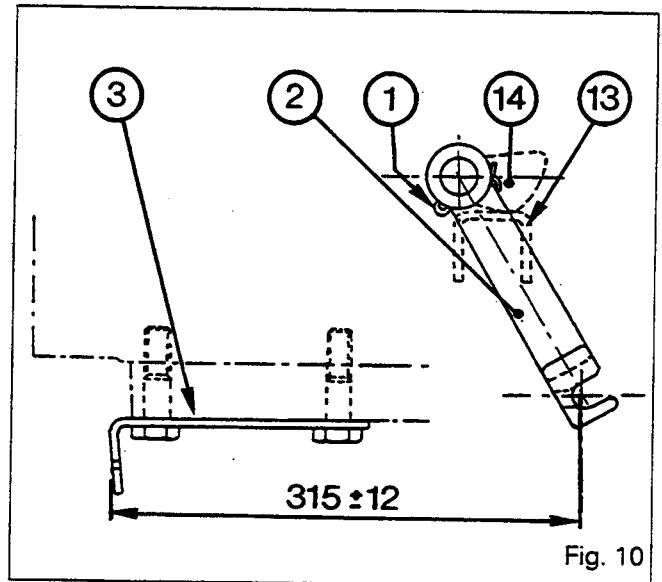

Fig. 10

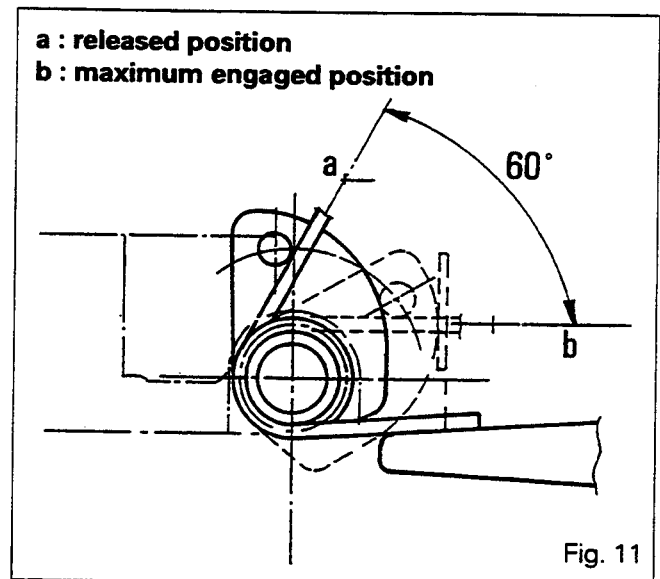

Fig. 11

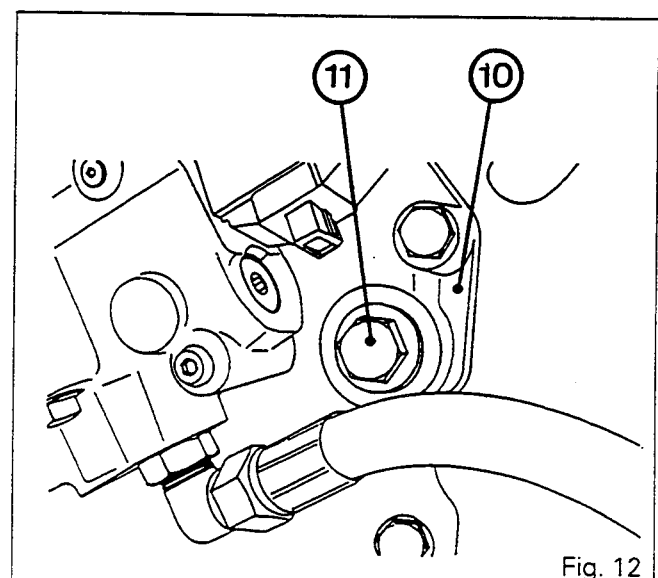

Fig. 12



## Rear Axle - Handbrake

65. Top up the oil level of the rear axle housing.
66. Check the operation of the electrical circuits, of the low pressure switch, of the solenoids and of the filter vacuum switch.
67. Check the operation of the lift.
68. Check for leaks at the joint faces, covers and hydraulic connectors.

### C. Fitting and adjustment of control

69. Introduce the cable (1) from below towards the cab interior and fasten with the clip (2) (Fig. 13).

70. Fix the cable end (7) on the brake lever (4) with the pin (5), the washer (6) and the split pin (3) (Fig. 13).

**Note: Check that the cable is not constrained.**

71. Fit the outer cable stop (2) in the bracket (1) (Fig. 14).

72. Attach the end of the cable (7) to the lever (6) (Fig. 14).

73. Place the handbrake lever in the released position. Adjust so as to obtain a distance of  $315 \text{ mm} \pm 12$  between the nut (5) and the axis of the end of the cable (7) (Fig. 14).

74. Tighten the lock-nut (3) on the washer (4) (Fig. 14).

**Note: For good alignment of the outer cable stop (2) and the cable (7), the nut (5) and the lock-nut (3) are mounted in front of the bracket (1) (Fig. 14).**

75. Check the operation of the control.

- Pull the lever. Initial travel should be approximately 8 notches. The warning light on the instrument panel should come on.
- Release the lever. The control should revert freely to the rest position and the warning light on the instrument panel should go off.

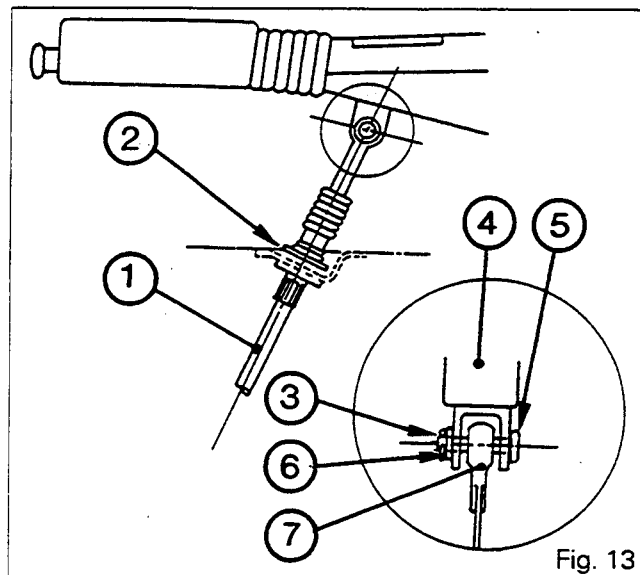

Fig. 13

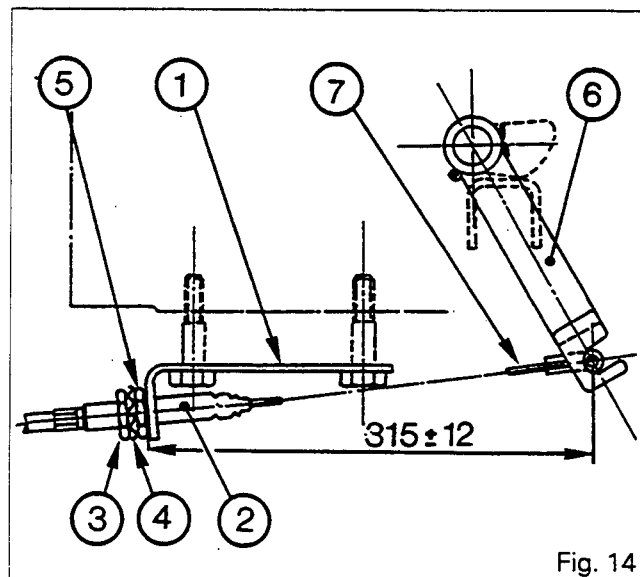

Fig. 14



6D01.10

6100 SERIES TRACTORS



Rear Axle - Handbrake

D . Buzzer wiring diagram

C21 - 2 way - Black connector

1 - Clutch pedal upper switch

2 - Handbrake buzzer

Color code

J : Yellow

R : Red

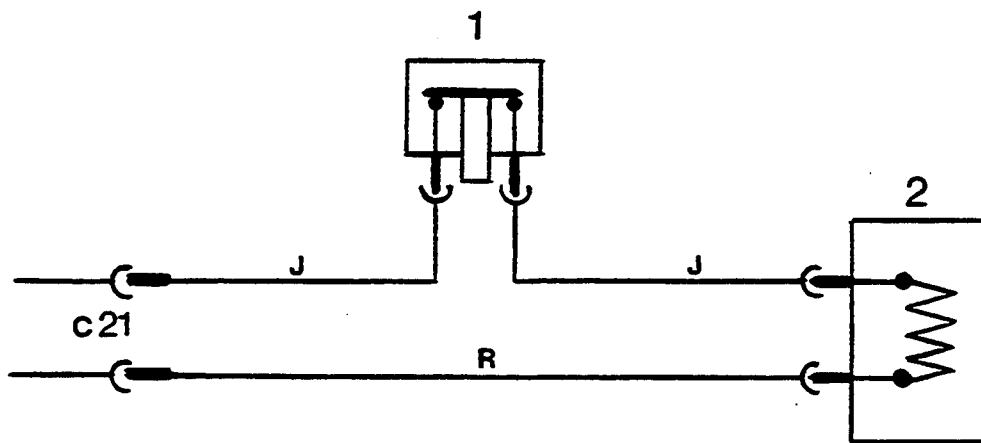



## **Rear Axle - Differential**

### 6 E01 Differential

#### CONTENTS

- <b>General</b> .....	2
<b>A. Removal of left hand carrier cover and of differential lock assembly</b> .....	5
<b>B. Disassembly and reassembly of differential lock</b> .....	5
<b>C. Refitting of left hand carrier cover and of differential lock assembly</b> .....	6
<b>D. Removal of differential assembly</b> .....	8
<b>E. Disassembly of differential assembly and crownwheel</b> .....	9
<b>F. Removal and disassembly of bevel drive pinion</b> .....	10
<b>G. Reassembly of crownwheel and differential assembly</b> .....	11
<b>H. Reassembly and refitting of bevel drive pinion</b> .....	11
<b>I. Refitting of differential assembly</b> .....	14
<b>J. Service tool</b> .....	18





6E01.2

## 6100 SERIES TRACTORS

**Rear Axle - Differential****General**

The bevel crownwheel and pinion, whose movement is provided by the output shaft of the gearbox, drives the rear axle through a connecting shaft.

The helical bevel drive pinion is supported on either side by taper roller bearings.

The bearing cones are force-fitted on the pinion, and the rear bearing cup is also force-fitted in the rear axle housing. The front bearing cup moves freely in its bore to enable the shimming of the pinion.

The crownwheel is fixed to the differential housing by rivets. The differential assembly turns on two taper roller bearings supported by two side carriers screwed on to the rear axle housing.

The differential assembly comprises two housing halves containing four planetary pinions and two sun gears.

The pinion is fitted in the rear axle housing with a preload obtained by means of shims placed between the handbrake backing plate and the axle housing.

The shimming of the differential assembly is carried out with deflectors (shims) of different thicknesses placed behind the bearing cup of the left hand cup bearing.

**Differential lock**

The left hand carrier houses the differential lock mechanism.

The system comprises a piston and a splined sliding coupler rotating with the left sun gear. The piston acts on the sliding coupler when pressure from the 17 bar hydraulic circuit is supplied by the solenoid valve fitted on the right hand cover. The piston moves, pushing the sliding coupler and compressing the spring.

The teeth of the sliding coupler engage with a fixed coupler attached to the differential housing. In this position, the sun gears of the right and the left hand trumpet housings turn at the same speed. When the pressure is released, the coupler moves back towards the rear under the influence of the spring.

**Specifications**

**J1** = Play between sun gears and planetary gears = 0,08 to 0,30 (measured at pitch diameters).

**J2** = Backlash = 0.15 to 0.40

**P1** = Preload = 0,05 to 0,12.

**P2** = Shim with **[13]** deflector to obtain a preload of 0 to 0,25.

**List of parts**

- (1)** O-ring
- (2)** Bolt
- (3)** O-ring
- (4)** Circlip
- (5)** Piston
- (6)** Spring
- (7)** Sliding coupler
- (8)** O-ring
- (9)** Left hand carrier
- (10)** Differential lock hydraulic assembly
- (11)** Thrust washer
- (12)** Finger
- [13]** Deflector (shim)
- (14)** Bearing cup
- (15)** Screw
- (16)** Coupler
- (17)** Bearing cone
- (18)** Washer
- (19)** Sun gear
- (20)** Planetary pinions
- (21)** Washer
- (22)** Cross joint
- (23)** Crownwheel
- (24)** Rivet
- (25)** Right hand carrier
- (26)** Bolt
- (27)** Bearing cup
- (28)** Bearing cone
- (29)** Crownwheel carrier
- (30)** Bearing cone
- (31)** Bearing cone
- (32)** Bolt
- (33)** Bearing cup
- (34)** Bevel drive pinion
- (35)** Supporting plate
- [36]** Shim(s)
- (37)** Bearing cup
- (38)** Pipe
- (39)** Connector
- (40)** Differential lock supply tube
- (41)** Oil deflector



6100 SERIES TRACTORS



Rear Axle - Differential

6E01.3

Overall view

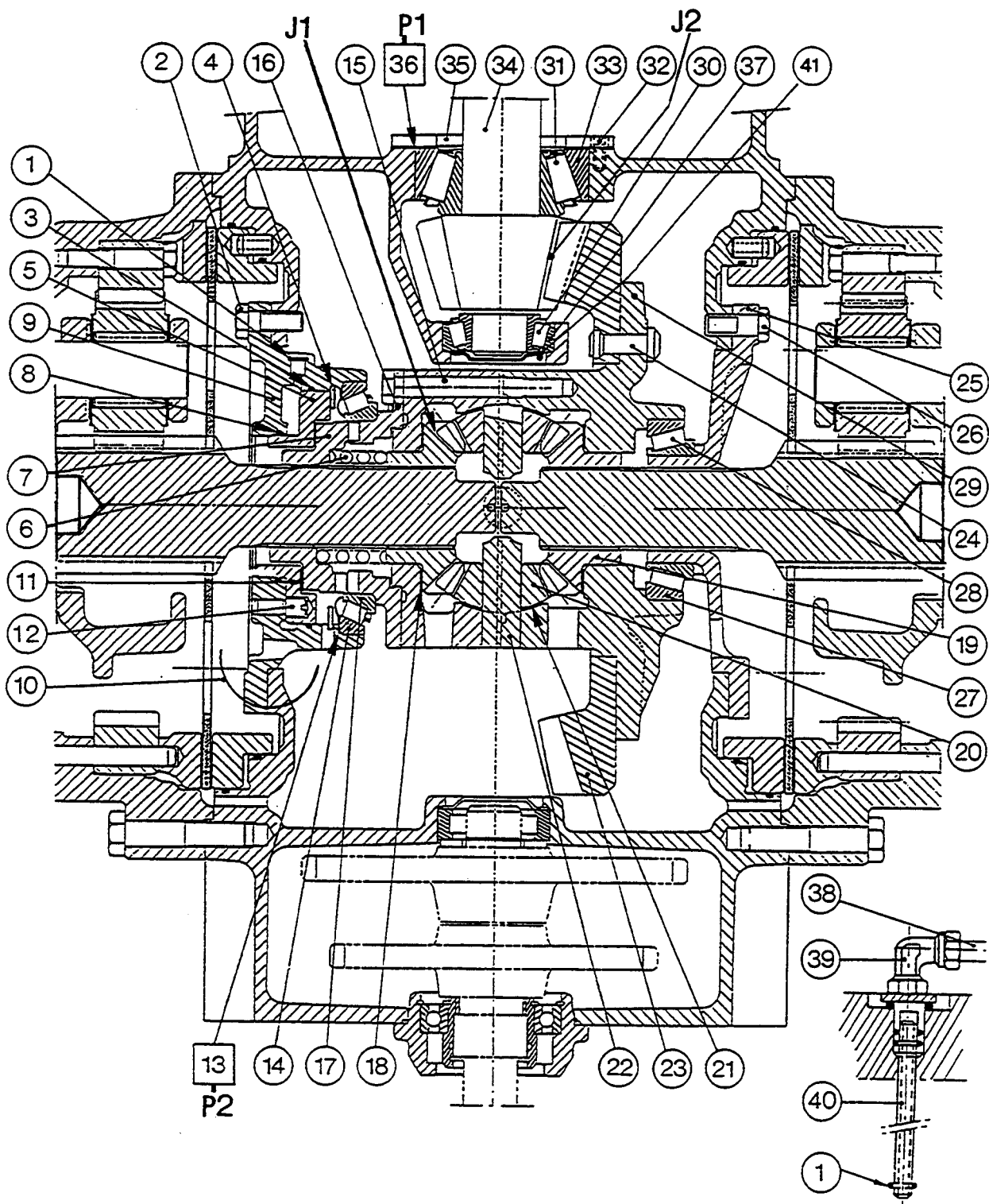



6E01.4

6100 SERIES TRACTORS



Rear Axle - Differential

Exploded view

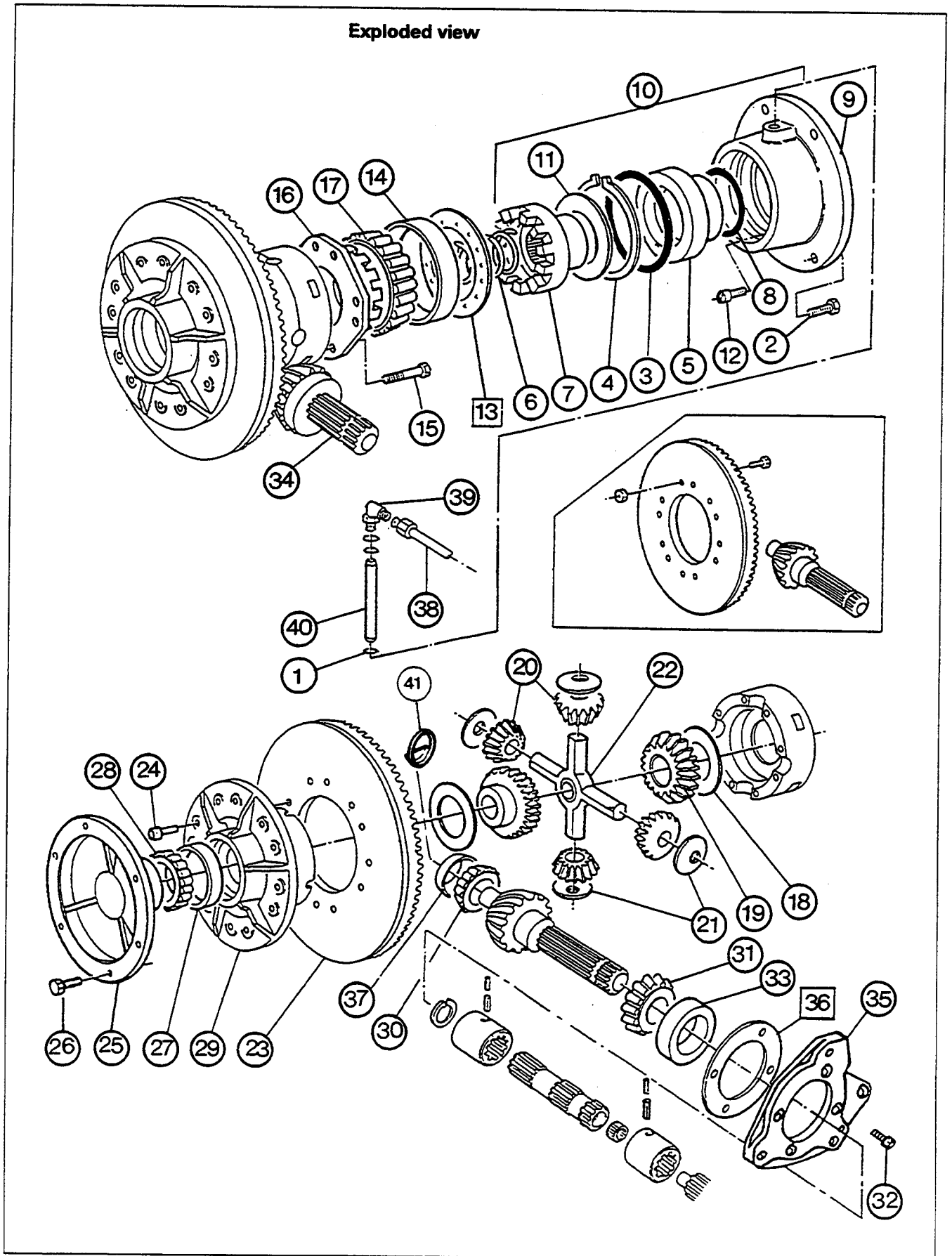



## Rear Axle - Differential

### A. Removal of left hand carrier and of differential lock assembly

**Note:** It is possible to work on the differential lock hydraulic assembly (10) with only the left hand axle housing removed.

1. Remove the left hand axle housing .

#### 6110 to 6170 tractors

Carry out operations 1 to 17, chapter 6C01.A.

#### 6180 and 6190 tractors

Carry out operations 1 to 15, chapter 6C02.A.

2. Disconnect the supply tube (38), unscrew the connector (39) and withdraw the tube (40) (Fig. 1A).  
**If access to the connector (39) is difficult on "economy 4-speed PTO" tractors, remove the control (1) (Fig. 1A).**
3. Remove the brake piston (see section 6F01, Part A).

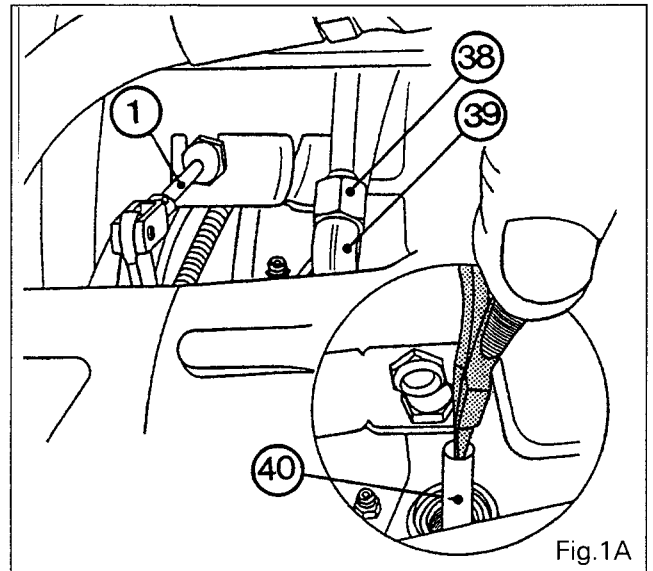

Fig.1A

### Special points

On tractors equipped with a closed centre hydraulic circuit, bolt "V" (Fig. 5A) also supports the return tube (1) from the auxiliary spool valves inside the centre housing (Fig. 1B).

On tractors with economy 4-speed PTO, continue with disassembly by removing the top link support, the compound pinion and the fork (see section 7A01). Loosen the bolts (2) alternately so as to release the spring (6) gradually.

4. Remove the carrier (9), the washer (11), the sliding coupler (7) and the spring.

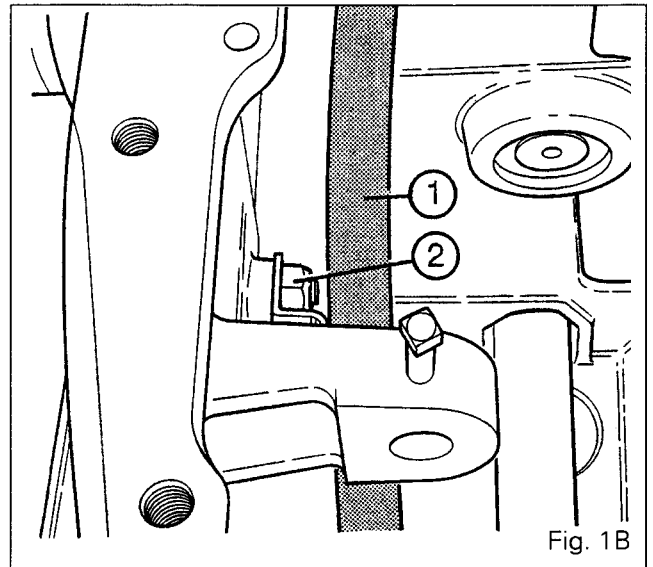

Fig. 1B

### B . Disassembly and reassembly of differential lock

#### Disassembly

5. Withdraw the bearing cup (14) and the deflector [13].  
**Note : Mark the direction of mounting of the deflector.**
6. Remove the circlip (4).
7. Withdraw the piston (5) with the aid of a jet of compressed air (Fig. 2).
8. Remove the O-rings (3), (8) and (1).
9. Unscrew the finger (12) (if necessary).

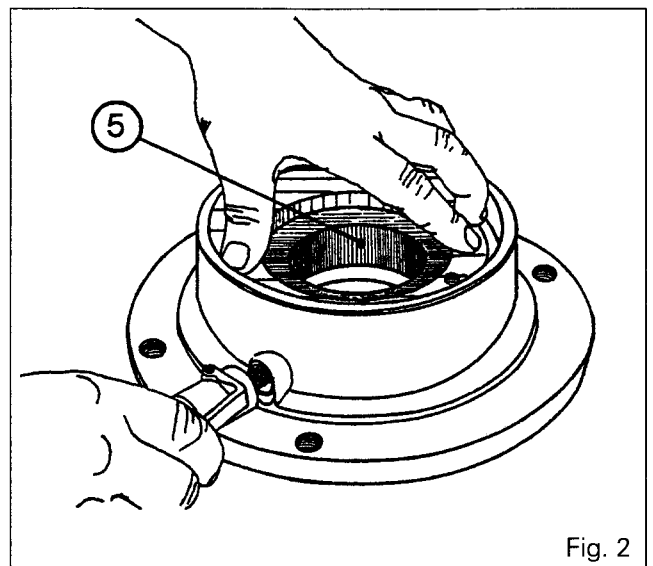

Fig. 2



6E01.6

## 6100 SERIES TRACTORS

**Rear Axle - Differential****Reassembly**

10. Check the parts and replace any which are defective.
11. Clean the finger (12), smear it with Loctite 221, then fit and tighten it on the carrier (9).
12. Smear the O-rings (3) and (8) with miscible grease (Amber Technical or equivalent), in order to retain them correctly in the bottom of their respective grooves.
13. Using a plastic mallet, fit the piston (5) back in the carrier (9) (Fig. 3), paying attention to the position of the finger (12).
14. Fit the circlip (4), the deflector [13] ensuring that it is fitted the right way round and the bearing cup (14) (Fig. 4).

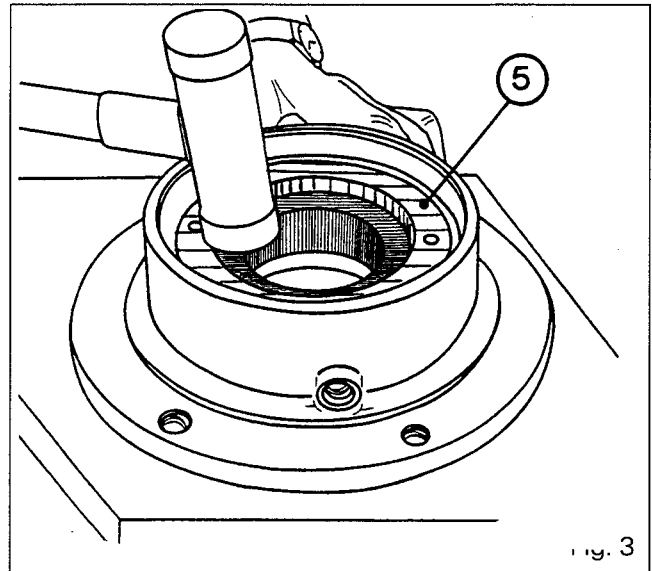

Fig. 3

**C. Refitting of left hand carrier and of differential lock assembly**

15. Fit the O-ring (1).
16. Assemble the washer (11), the sliding coupler (7) and the washer (6).
17. Reinstall the assembly in the left-hand carrier (9).

**Centring the carrier (9)**

To ensure that the brake self-adjustment system operates correctly, it is mandatory to centre the carriers as from serial number E275051 and until serial number E326018. A locally manufactured centring device is to be used for this purpose (see page 17).

**Centring method (Fig. 5A)**

18. Screw a guide stud "G" (60 mm long) onto the centre housing.

Fit the carrier assembly with the oil channel facing downwards.

Position the centring device "C" on the opposite side from the guide stud "G".

Fit and tighten two bolts (2) evenly and alternately to a torque of between 85 and 130 Nm, checking that the centring device "C" remains free during the whole operation.

Replace the centring device and the guide stud with two other bolts, tightened to the recommended torque.

If necessary, carry out the operations described under "Special points" in Part A in the reverse order.

**Note: As from serial number E3216019, each bearing face on the differential carriers is fitted with a centring bush (1) (Fig. 5B) so the centring device "C" need not be used.**

19. Fit the tube (40) and the connector (39) (Fig. 1A).

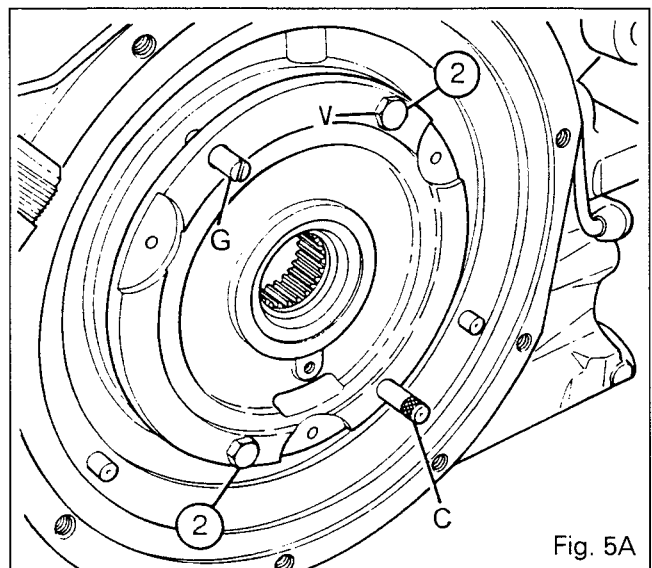
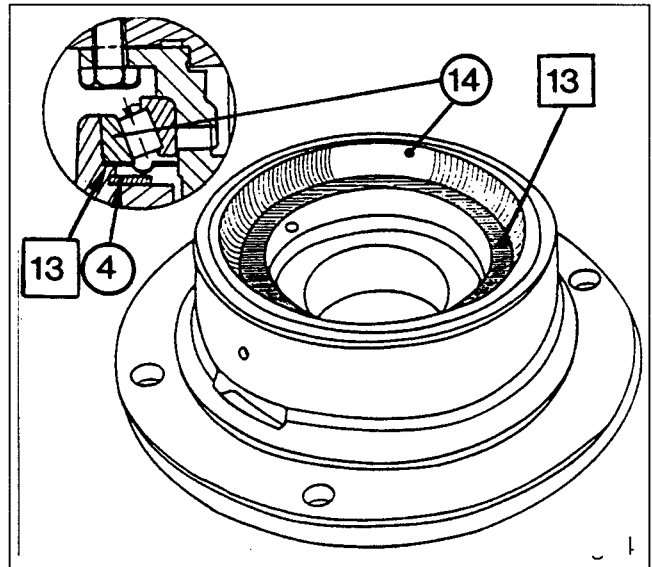

Fig. 5A



## Rear Axle - Differential

### Leak test

After working on the piston **(5)**, the seals **(3)** and **(8)** and the carrier **(9)**, it is necessary to check the assembly for leaks.

20. Fit a pressure gauge and valve on the supply connector **(39)** (Fig. 6).

21. Feed compressed air at approximately 5 bar into the system in order to position the piston and O-rings correctly.

Reduce the pressure to 0.3 bar to carry out the leak test.

22. Close the valve. Over 1 minute the pressure gauge should not show any drop in pressure.

23. Disconnect the pressure gauge and connect the supply pipe **(38)** (Fig. 1A).

**If removed:** Reconnect the "economy 4-speed PTO" control and carry out the adjustment, see section 7A01.

Reinstall the brake piston (see section 6F01, Part B).

24. Reinstall the left-hand trumpet housing.

#### 6110 to 6170 tractors

Carry out operations 18 to 36, chapter 6C01.A.

#### 6180 and 6190 tractors

Carry out operations 16 to 33, chapter 6C02.A.

25. Check for leaks of the supply pipe **(38)** (Fig. 1A) and the operation of the differential lock.

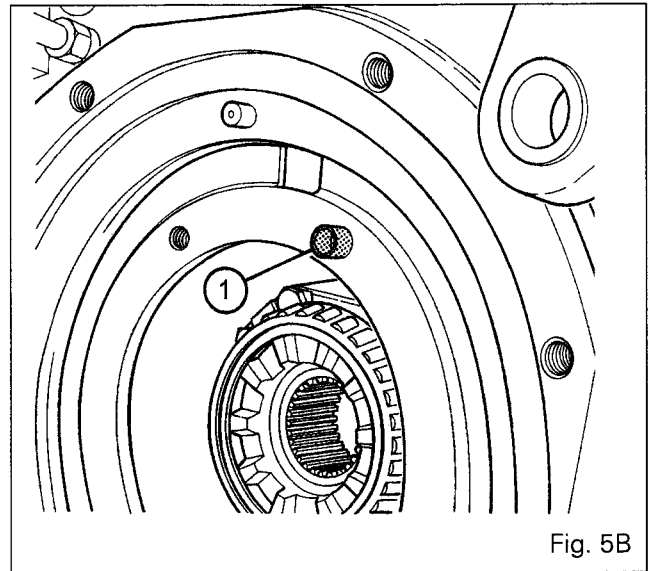

Fig. 5B

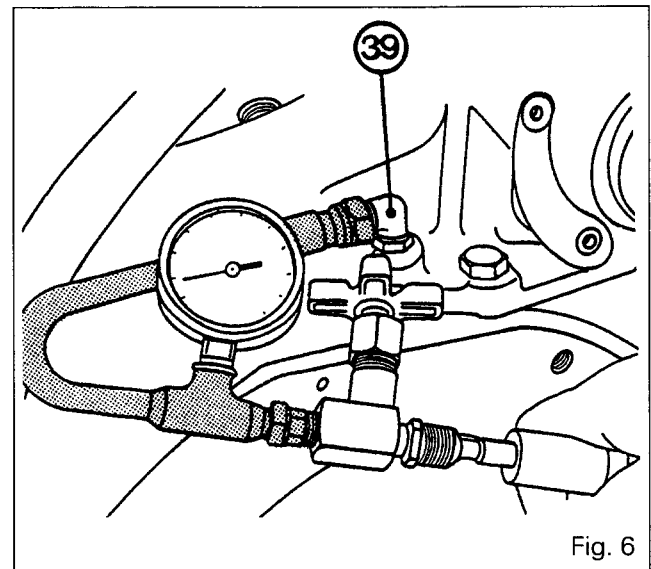

Fig. 6



6E01.8

## 6100 SERIES TRACTORS

**Rear Axle - Differential****D. Removal of differential assembly**

26. Immobilise the tractor. Apply the handbrake. Chock the front wheels and the axle frame (see 2A01 - Fig. 1).
27. Drain the rear axle only.
28. Lift the rear of the tractor with a trolley jack.
29. Place stands under the rear axle housing.
30. Remove the wheels.
31. Remove the right and left hand axle housing.

**6110 to 6170 tractors**

Carry out operations 6 to 17, chapter 6C01.A.

**6180 and 6190 tractors**

Carry out operations 6 to 15, chapter 6C02.A.

**Note: Check the space between the hood and the windscreen. (If the space is too narrow, remove the sheet metal.)**

On both series of tractor, the cab should be supported on either side with suitable stands in front of the front support of the tank (Fig. 7). On the right hand side, pay attention to the heating pipes. If necessary, unscrew the fastening brackets.

32. Disconnect the fuel supply and return hoses and the harness to the tank gauge.

**Note: Mark the harness connectors.**

33. Partly empty the tank. Remove the fuel tank and then the tank support.
34. Remove the lift cover, see section 6B01.
35. Remove the top link support, the drive pinion and the layshaft.

**2-speed PTO tractors**

See section 7A01, Part A

**4-speed PTO tractors**

See section 7A01, Part C

36. Remove the pipe (40) (Fig. 8).
37. Support the differential assembly using a hoist and a G clamp (Fig. 9).
38. Before working on bolts (2), consult the paragraph on "Special points" in Part A. Loosen the nuts (2) alternately so as to release the spring (6) gradually.
39. Remove the carrier (9), the spring (6), the coupler (7) and the washer (11).
40. Remove the bolts (26).
41. Remove the cover (25).
42. Withdraw the differential assembly from the housing (Fig. 9).

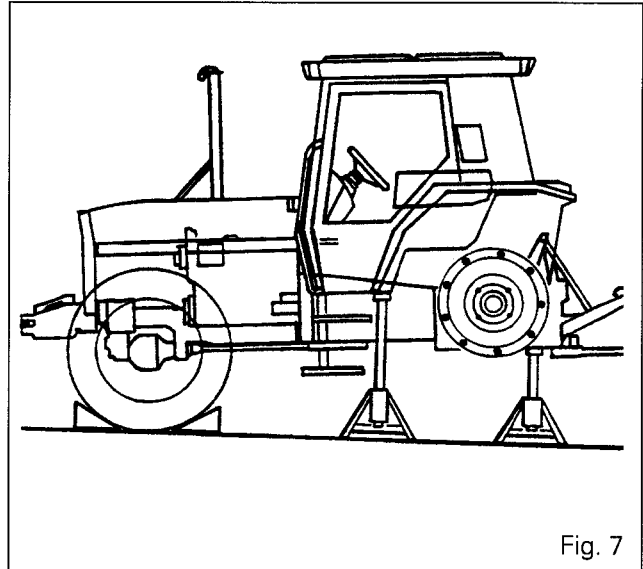

Fig. 7

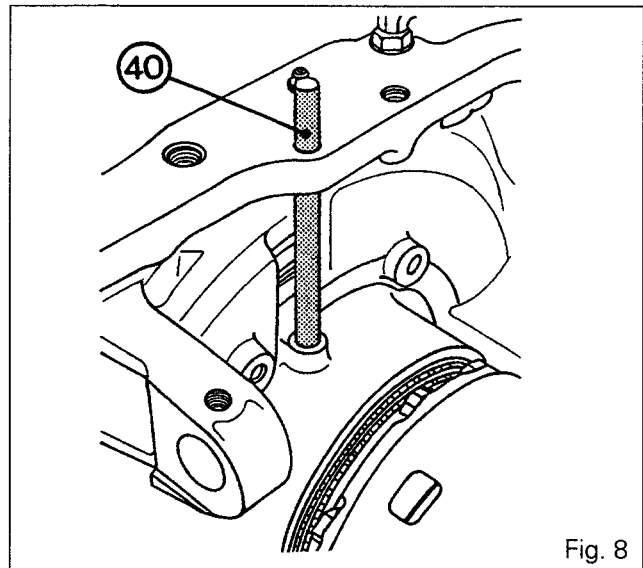

Fig. 8

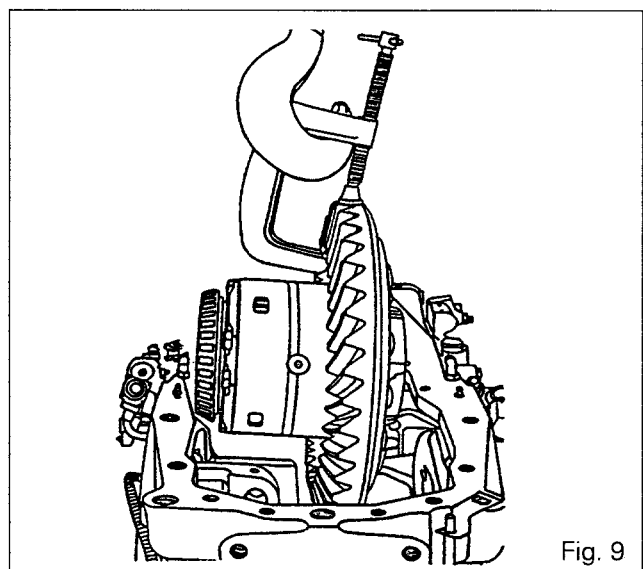

Fig. 9



## Rear Axle - Differential

### E. Disassembly of differential assembly and crownwheel

43. Place the assembly on a workbench.
44. Remove the bearing cones (17) - (28) and the cup (27).
45. Remove the screws (15).
46. Remove the fixed coupler (16).
47. Separate the two parts of the housing (29).

**Note: These pieces each have the same number. They must be paired.**

48. Remove the washers (18), the sun gears (19), the planetary pinions (20), the washers (21) and the cross joint (22) (Fig. 10).

**Note: When the crownwheel is replaced, the bevel drive pinion must be replaced as well. These pieces each have the same number and must be paired.**

**In the factory the crownwheel and the carrier are assembled by means of rivets.**

**For the purposes of repair, the rivets are replaced with screws and nuts.**

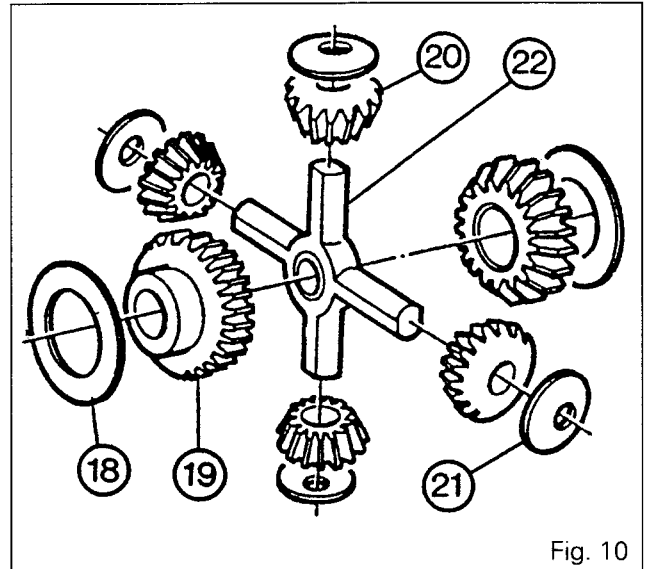

Fig. 10

### Disassembly of the crownwheel (23)

49. Remove the crownwheel from the housing.
50. Make a centre mark in the centre of each rivet (24) (crownwheel teeth side).
51. Drill the rivets to a depth of 10 mm with a 5 mm diameter drill (Fig. 11).
52. Drill out to a diameter of 12 mm and to the same depth.
53. Drive the rivets out with a suitable drift punch (Fig. 12).

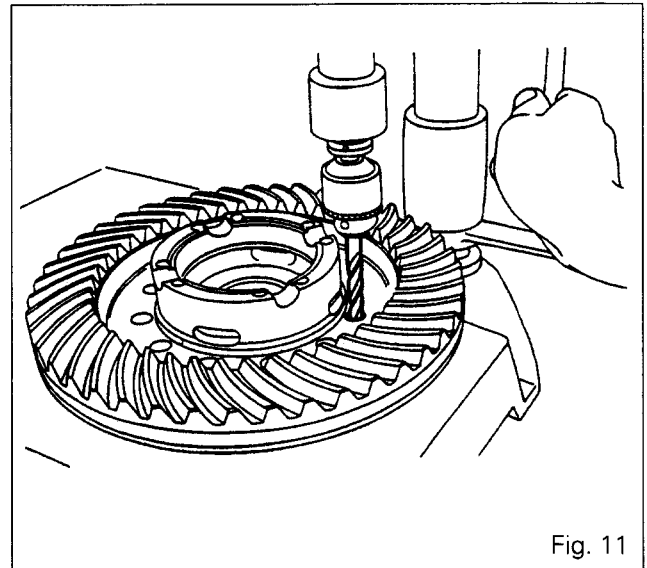

Fig. 11

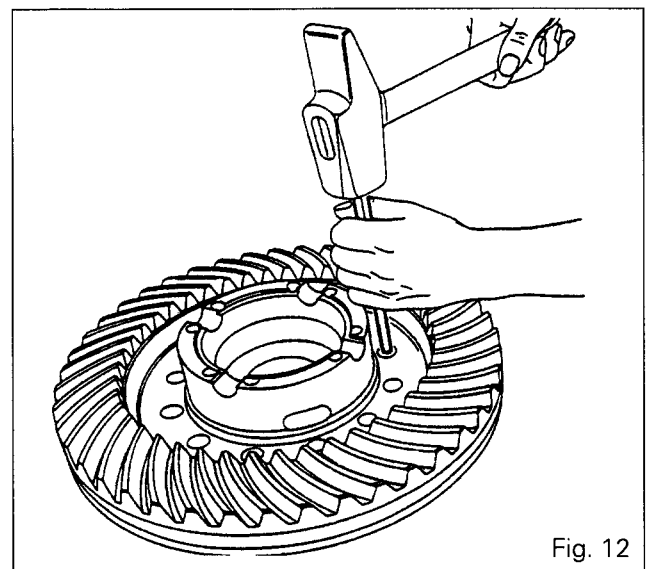

Fig. 12





6E01.10

## 6100 SERIES TRACTORS

**Rear Axle - Differential****F. Removal and disassembly of bevel drive pinion**

54. Remove the clogging indicator. Remove the main 15-micron filter with its support and the right-hand hydraulic cover. Carry out operations 2 to 14, in section 9I01 (open centre) or 9T01 (closed centre).
55. Remove the left-hand cover. Carry out operations 3 to 6, in section 9I02 (open centre) or 9T02 (closed centre).

**Tractors without creeper gears**

56. Drive out the double pins (2) and (4) from the sleeves (1) and (5). Slide the sleeves towards one another on the shaft (3) linking the drive pinion (6) and the output shaft (7) of the gearbox (Fig. 13). Remove the shaft and sleeves assembly.

**On 4WD tractors**

If the double pins are not accessible, slide the rear sleeve forwards on the 4WD shaft. Rotate the wheel shaft so as to position the coupling sleeve (3) (Fig. 13).

57. Remove the circlip (1).
58. Remove the pinion (2) (if fitted) (Fig. 14).

**Tractors with creeper gears**

59. Remove the creeper gears fork and the sleeve assembly (connecting shaft and coupler).
60. Remove the circlip (1) and the pinion (2) (if fitted) (Fig 14).

**Tractors with or without creeper gears**

61. Remove the handbrake mechanism assembly. Carry out operations 15 to 25, chapter 6D01.
62. Remove the screws (32), the supporting plate (35) and the shims [36].
63. Remove the bearing cup (33) and the bevel gear pinion fitted with bearing cones (30) and (31).
64. Remove the bearing cup (37). Remove the oil deflector (41).

**Disassembling the drive pinion**

65. Extract the bearing cones (30) and (31).

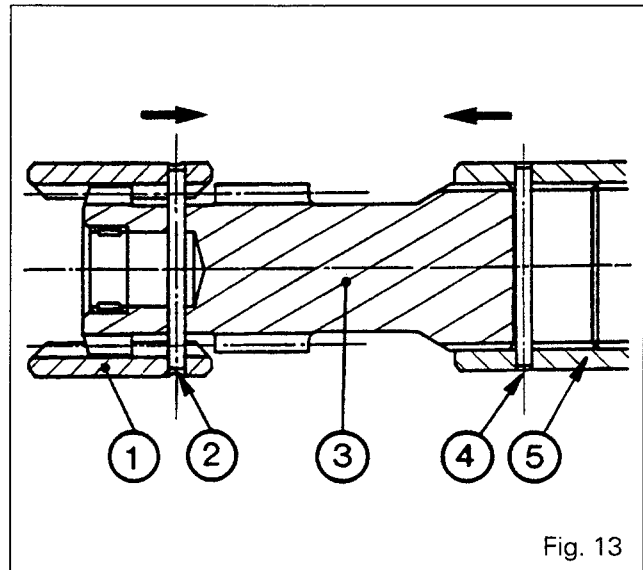

Fig. 13

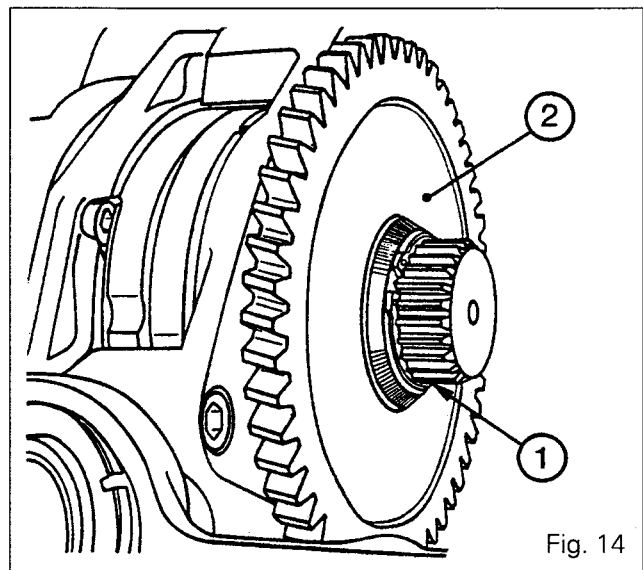

Fig. 14



## Rear Axle - Differential

### G. Reassembly of crownwheel and differential assembly

66. Check that the crownwheel and the bevel gear pinion have the same number.
67. Clean the contact faces of the new crownwheel (23) and of the carrier (29) and the screws and nuts referred to in the spare parts catalogue.
68. Smear the screws (1) (Fig. 15) with Loctite 270 on the first threads and place them in the crownwheel and carrier.
69. Tighten and lock the nuts (2) (Fig. 15) to a torque of 150 -160 Nm.

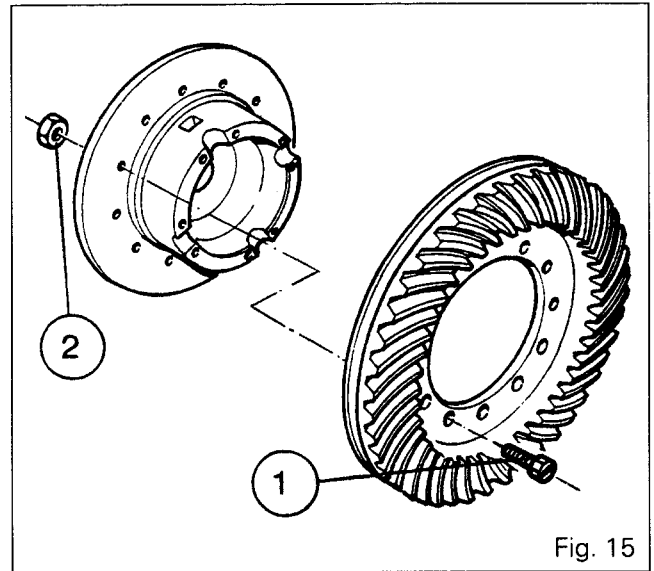

Fig. 15

### Reassembly of differential assembly

70. Check the parts and replace any which are defective.
71. Reverse operations 46 to 48.
72. Smear the screws (15) with Loctite 270, then tighten them to a torque of 85 - 130 Nm.  
**Note: The clearance J1 between the planetary pinions and the sun gears must be between 0.08 and 0.30.**
73. Push the bearing cup (27), the bearing cones (17) and (28) against the shoulder with the aid of a press and a suitable device.

### H. Reassembly and refitting of the bevel drive pinion

#### Reassembly

74. Check the parts, replace any which are defective.
75. Using a press and a suitable device, push the bearing cones (31) and (30) against the bevel drive pinion.

#### Refitting

76. Smear the oil deflector (41) with Loctite 648 and position it in the bore in the housing (Fig. 16).  
**Note: The oil deflector (41) must be fitted so that it is flush with face F. Position the hole T so that the lubricating pipe can be assembled (if fitted).**



6E01.12

## 6100 SERIES TRACTORS

**Rear Axle - Differential**

77. For 6190 tractors only, determine the required thickness **E** of shims **[42]** (Fig. 16) by means of the following formula:

$$E = Z + t - (x + y)$$

$$E = 184.955 + t - (x + 86.325)$$

where:

**Z** = nominal dimension of drive pinion = 184.955

**t** = correction of nominal dimension engraved on the end of the drive pinion and which can be positive or negative.

**x** = dimension of centre housing, stamped on the rear right-hand section of the centre housing

**y** = dimension of the drive pinion with bearing = 86.325

78. Smear the outside diameter of the cup **(37)** with Loctite 603 and fit it fully home against the shoulder using a suitable fixture. Remove any traces of Loctite.

**Note: The bearing cones and cups must be cleaned and lubricated after fitting.**

79. Fit the shims **[42]** selected in operation 77. Fit the drive pinion and cup **(33)**.

**Note: It is mandatory to carry out the adjustment of the conical distance (on 6190 tractors only) before the adjustment of preload P1.**

80. In order to prepare shimming **P1**, determine a shim thickness greater than the dimension "a" by which the cup **(33)** protrudes from the face of the housing (Fig. 18) so as to obtain a play of 0.10 to 0.15 maximum.

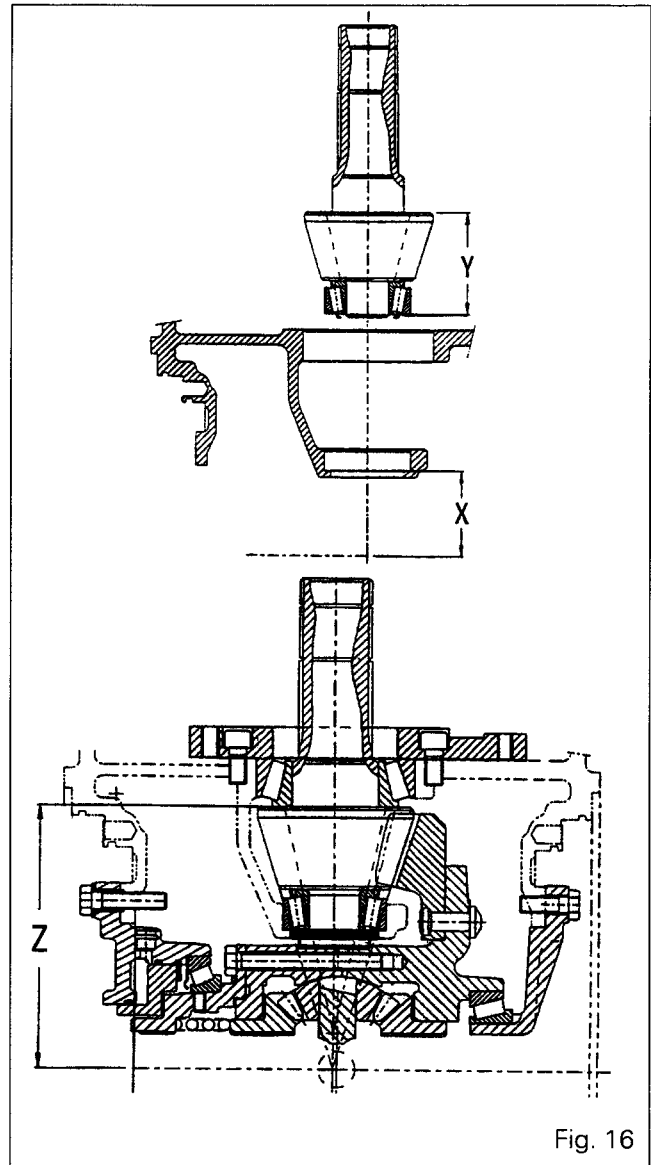

Fig. 16



## Rear Axle - Differential

81. Bolt two guide studs in opposite positions into the housing. Fit the shims [36] of the thickness determined in operation 78 and the supporting plate [35].
82. Fit the bolts (32), remove the guide studs and tighten to a torque of 90 - 120 Nm.
83. Carry out shimming (Fig. 18) to obtain:  
 $P1 = 0.05$  to  $0.12$

### 1st method: (rear axle on tractor or on a support)

84. Place the tip of a dial indicator against the drive pinion (Fig. 19).
85. Through the opening for the right hand hydraulic cover, pull on the pinion shaft turning it back and forth to ensure the bearing cones and cups are correctly seated.
86. Now set the dial indicator to zero.
87. Repeat operation 85 while pushing.
88. According to the reading on the dial gauge, select the required thickness of shims to obtain  $P1$ .
89. Remove two bolts (32), bolt in two guide studs. Remove the two other bolts and the supporting plate (35).
90. Fit the shims [36] selected in operation 88 and refit the supporting plate.
91. Fit the bolts (32) smeared with Loctite 270. Remove the guide studs and tighten to a torque of 90 - 120 Nm.

### 2nd method (rear axle on a support only)

The principle involves removing or adding shims [36] to obtain a torque of 0.20 to 1.50 Nm measured with a dynamometer.

**Note: If possible, shim so as to obtain the nominal torque. Each time bolts (32) are reinstalled, it is mandatory to always tighten them to a torque of 90 to 120 Nm.**

On final refitting, smear the bolts with Loctite 270 and apply the above-mentioned torque.

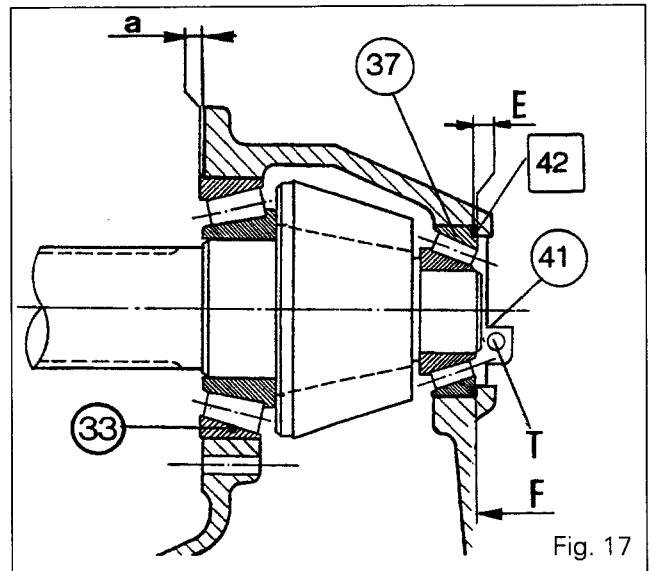

Fig. 17

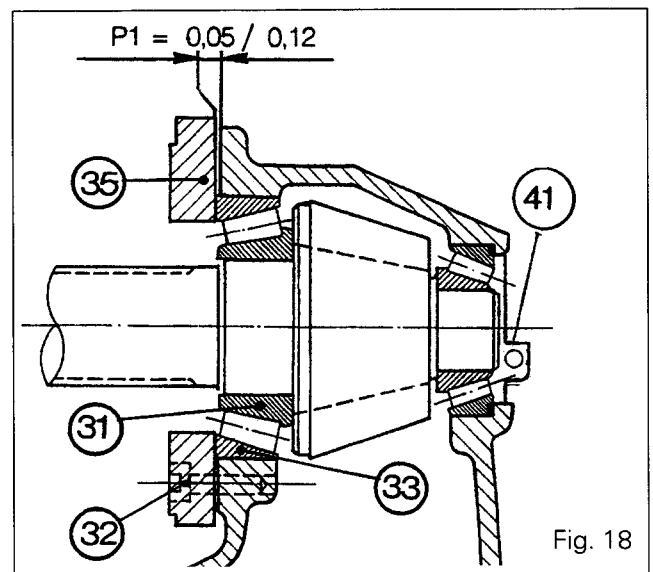

Fig. 18

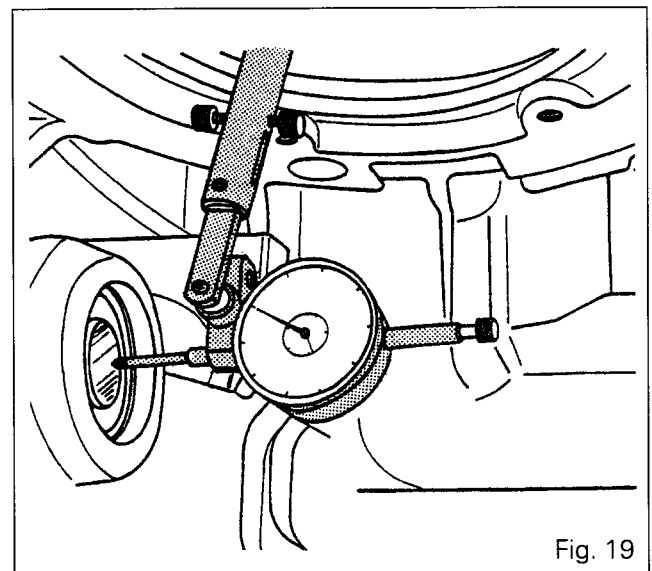

Fig. 19



6E01.14

## 6100 SERIES TRACTORS



## Rear Axle - Differential

## I. Refitting of differential assembly

92. Place the differential assembly in the housing (Fig. 20).

### Centring the carrier (25)

To ensure that the brake self-adjustment system operates correctly, it is **mandatory** to centre the carriers as from serial number E275051 and until serial number E326018. A locally manufactured centring device is to be used for this purpose (see page 18).

93. Use the centring method described in Part C. The procedure for the centring of the right-hand carrier (25) is similar to that for the left-hand carrier (9). Reinstall the right-hand brake piston (see Section 6F01, Part B).

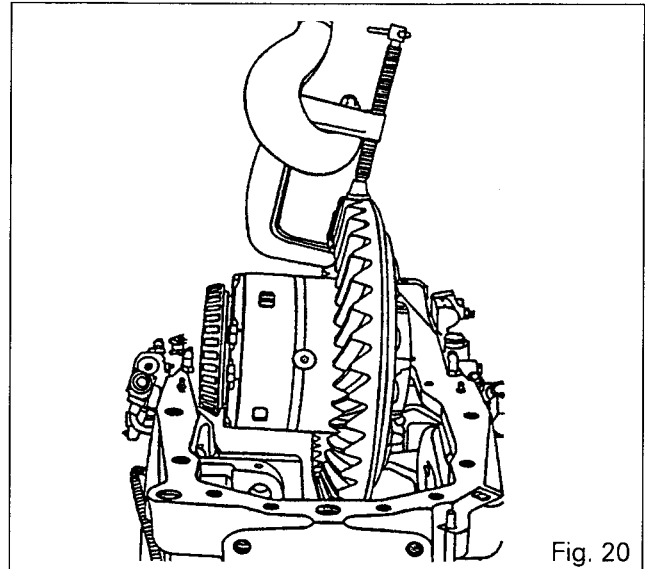

Fig. 20

### On the left-hand carrier (9)

94. Remove the cup (14) and the deflector [13] of the left hand carrier (9).

95. Place the cup on the bearing cone (17).

96. Mount tool 3376847 M91 in the housing using two bolts (2) tightened to a torque of 85 - 130 Nm (Fig. 20).

**Note: For 6100 tractors, use the shortest finger D of the tool (see § J).**

97. Tighten the central screw of the tool to a torque of 10 Nm (Fig. 20).

**Note: Turn the crownwheel a few times to "seat" the bearing cones correctly in the cups. Recheck the tightening torque of the central screw of the tool.**

98. Fit and tighten the hexagonal calibrated spacers (A) (Fig. 20) in the two other holes. Ensure they are in contact with the housing.

99. Now determine shims (Fig. 21) to obtain pre-load **P2 = zero to +0.25**

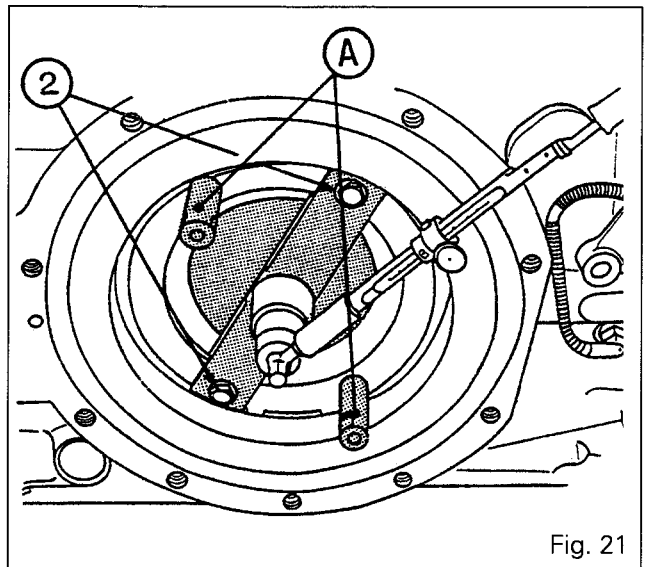

Fig. 21

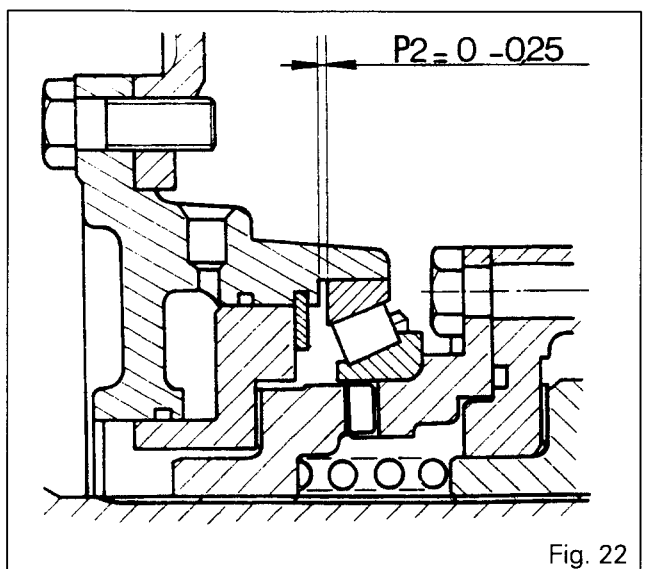

Fig. 22



# Rear Axle - Differential

6E01.15

100. Place a straight edge against the two calibrated spacers.
101. Measure the play **J** between the finger of the tool and the straight edge (**B**) with a feeler gauge (Fig. 23).
102. Calculate the distance **C** between the cup (**14**) and the contact face of the carrier (**9**) (Fig. 24).  
**C = (114 + J) - 70**
103. On the carrier (**9**), determine the distance **Y** with a depth gauge and a straight edge (Fig. 25).
104. Select the correct thickness of the deflector [**13**] (see table) to obtain:  
**P2 = C - Y**  
**Note: For carrying out shimming P2 there are eight deflectors of different thicknesses.**
105. Remove the tool and the cup (**14**).

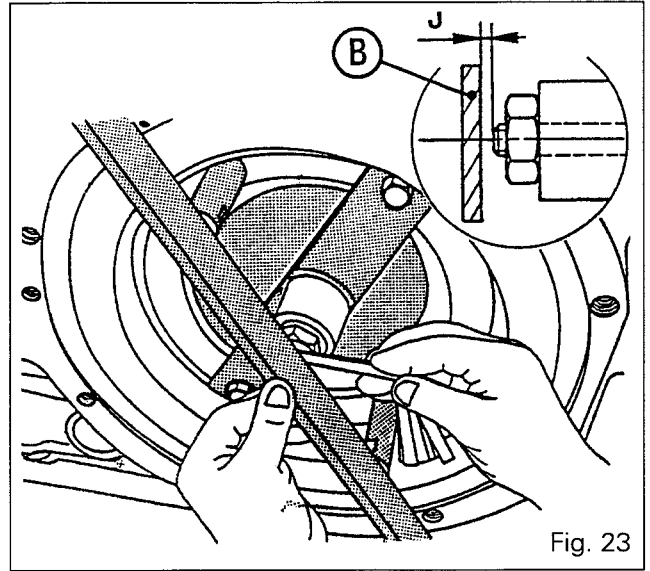

Fig. 23

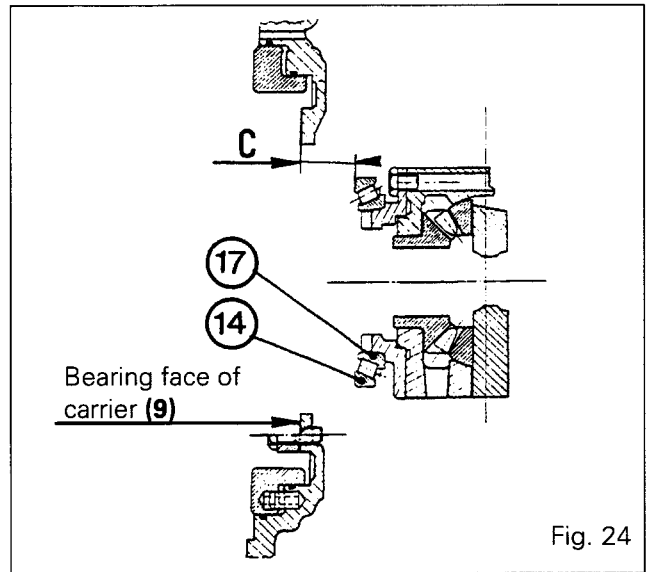
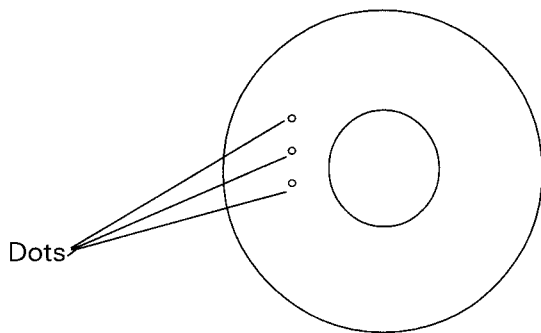

Fig. 24



Reference	Number of dots	mm
187 689 M1	0	0.73 - 0.78
892 173 M1	1	0.864 - 0.914
892 172 M1	2	0.991 - 1.041
892 171 M1	3	1.118 - 1.168
892 170 M1	4	1.245 - 1.295
191 124 M1	5	1.37 - 1.42
191 125 M1	6	1.49 - 1.54
521 401 M1	7	0.61 - 0.66

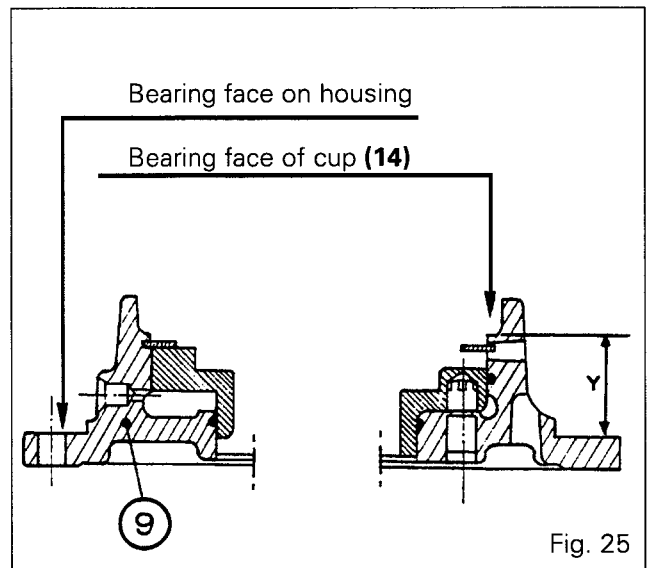

Fig. 25



6E01.16

## 6100 SERIES TRACTORS

**Rear Axle - Differential**

106. Place the deflector [13] selected in operation 104 and the cup (14) in the cover (9).

**Note: Ensure that the deflector is mounted the right way round (Fig. 26).**

107. Reinstall and centre the carrier (9). Carry out operations 16 to 18, in Part C.

108. Fit the tube (40).

109. Check the backlash between the crownwheel and bevel drive pinion:

**J2 = 0.15 to 0.40**

110. Place the tip of the dial gauge on a tooth of the crownwheel (Fig. 28).

**Note: Carry out this operation at four diametrically opposed points on the crownwheel. Clearance J2 is obtained as a function of the machining tolerances. If this clearance is outside the maximum tolerance, after shimming P2 has been carried out, it is possible to reduce the thickness of the deflector [13]. Place a shim of suitable thickness between the cup (27) and the carrier (29).**

111. Check clearance J2 again.

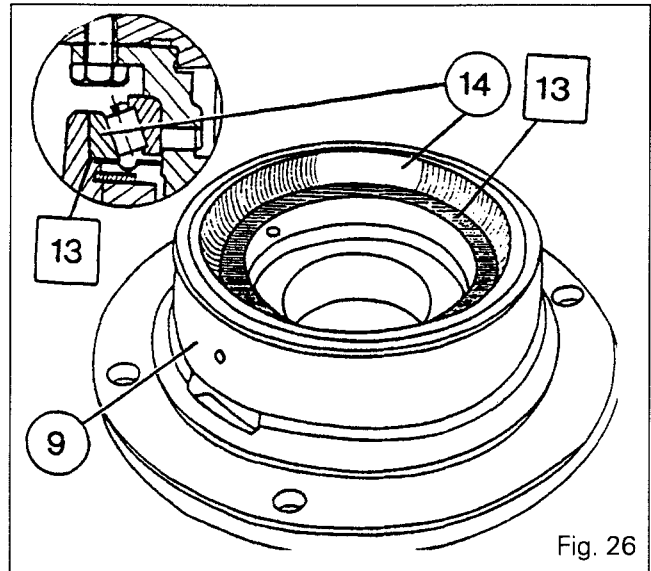

Fig. 26

### Refitting of the handbrake mechanism assembly

**Note: The plate /5\ is rectangular. It must be positioned horizontally, lengthwise, on the pin(6) in the lever (13) to be correct (Fig. 28).**

112. Carry out operations 39 to 47, chapter 6D01.

### Tractors with creeper gears

113. Refit the gear (2) (if mounted) and the circlip (1) (Fig. 29).

114. Refit the fork and the sleeve, connecting shaft and coupler assembly. Direct the slot of the sleeve fitted on the driving gear rearwards. Replace the pins. Adjust the fork (see section 5 D01.A). Reconnect the creeper gears control cable.

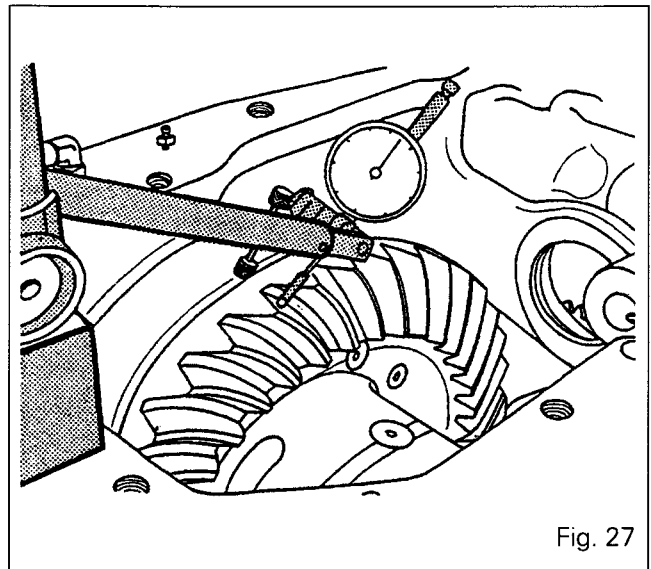

Fig. 27

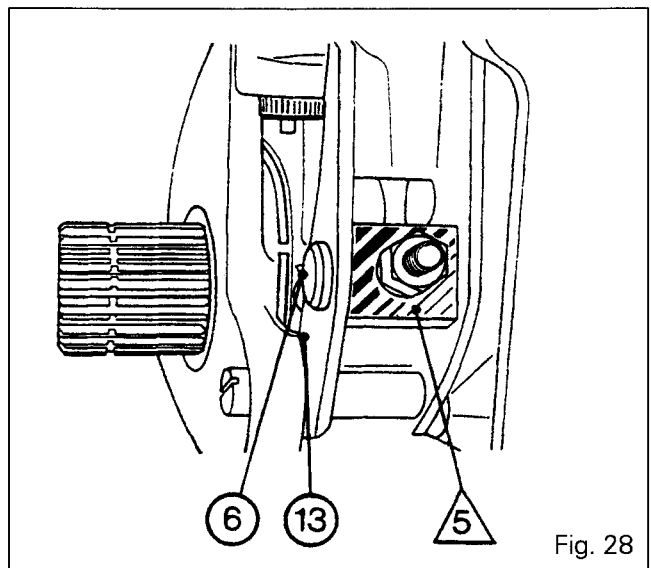

Fig. 28



## Rear Axle - Differential

### Tractors without creeper gears

115. Refit the gear **(2)** (if mounted) and the circlip **(1)** (Fig. 29).
116. Refit the sleeve, connecting shaft and coupler assembly. Direct the slot of the sleeve fitted on the driving gear as in operation 14. Replace the pins. The longest one is fitted on the gearbox output shaft.

### Tractors with or without creeper gears

117. Reinstall the left-hand cover, see section 9I02 (open centre) or 9T02 (closed centre).  
Fit the handbrake control support and the ground speed PTO support (if fitted). Remove the guide studs. Fit and tighten the bolts to a torque of 72 to 96 Nm.
118. Position the control rod and adjust the handbrake mechanism.  
Carry out operations 55 to 57, chapter 6D01.
119. Reconnect the G.S. PTO control (if fitted), the supply hose of the lift valve, the supply pipe of the rams and the lift and lowering valves (yellow connector). Clip the wire assembly to the valve supply hose.
120. Reinstall the right-hand hydraulic cover.  
Carry out operations 15 to 27, section 9I01 (open centre) or 9T01 (closed centre).
121. Refit the layshaft, the driving pinion and the top link support.

### Tractors with 2-speed PTO

See section 7A01, Part A.

### Tractors with 4-speed PTO

See section 7A01, Part C.

122. Reinstall lift cover, see section 6B01. Attach the wiring harnesses with a clamp. Reinstall the left-hand brake piston (see section 6F01, Part B).
123. Refit the fuel tank.  
Reconnect the fuel supply and return hoses and the harness of the tank gauge (connect as marked upon disassembly).
124. Refit the right hand and left hand trumpet housings.

### 6110 to 6170 tractors

Carry out operations 18 to 31, chapter 6C01.A.

### 6180 and 6190 tractors

Carry out operations 16 to 27, chapter 6C02.A.

Refit the stabiliser support.

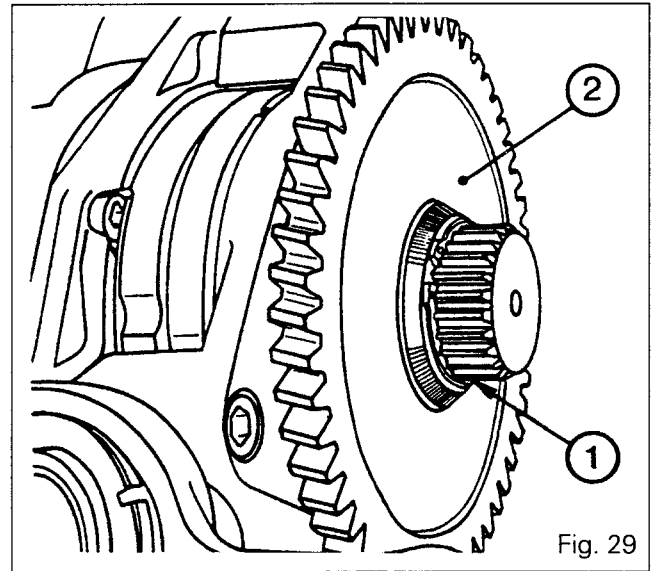

125. Refill with fuel.
126. Refit the support with the auxiliary spool valves. See section 6B01.
127. Check the adjustment of the controls:  
**Ground speed PTO** : See section 7D01.  
**Handbrake** : See section 6D01.  
**Shiftable PTO** : See section 7C01.  
**Economy 4-speed** : See section 7A01.  
**Creeper gears** : See section 5H01.
128. Raise the rear of the tractor with a trolley jack. Refit the wheels. Remove the stands under the rear axle. Tighten the wheel nuts to a torque of 400 - 450 Nm.
129. Top up the oil in the housing and remove the chocks. Refit the sheet metal (if removed).
130. Start the engine. Carry out a road test. Check the operation of the controls and of the electrical circuits.
131. Check for leaks of the joint faces of the trumpet housings on the centre housing, of the covers and of the hydraulic connectors.





6E01.18

6100 SERIES TRACTORS



Rear Axle - Differential

J. Service tools

1. Tool available from MF network

Shimming tool 3376847 M91 (Fig. 30).

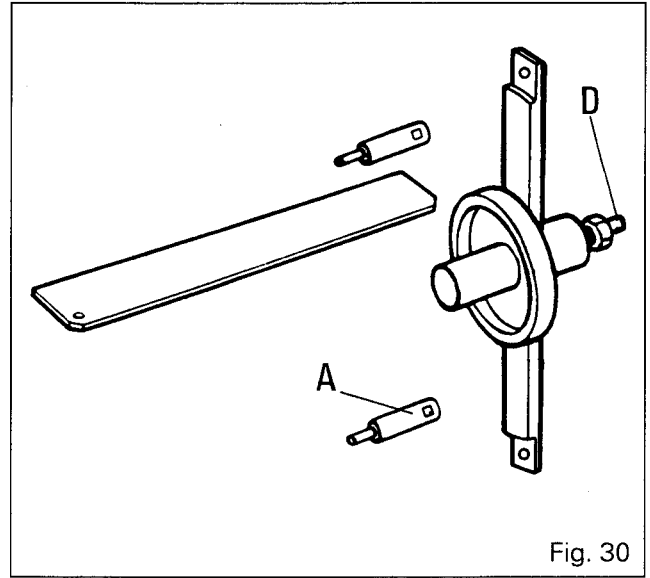
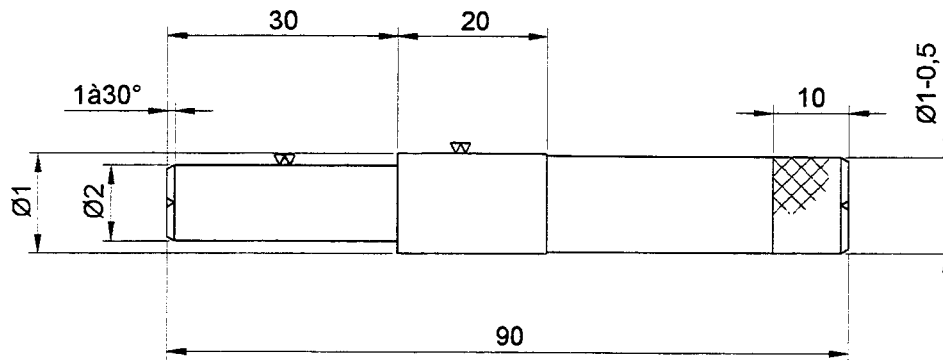

Fig. 30

2. Centring device to be manufactured locally

$\phi 1 = 13.35$  to  $13.40$

$\phi 2 = 10.10$  to  $10.15$





**Rear Axle - Brake pistons and seals**

*6 F01 Brake pistons and seals*

CONTENTS

- <b>General</b> .....	<b>2</b>
<b>A. Disassembly</b> .....	<b>3</b>
<b>B. Reassembly</b> .....	<b>4</b>
<b>C. Bleeding of main braking circuit</b> .....	<b>5</b>
<b>D. Bleeding of trailer braking circuit</b> .....	<b>7</b>



6F01.2

---

## 6100 SERIES TRACTORS

---



# Rear Axle - Brake pistons and seals

---

### General

---

The brake pistons are housed in two lateral cavities of the rear axle housing, concentric with the supporting face of each trumpet housing (see 6A01, page 4).

They comprise a shouldered part and are guided by 3 dowels force-fitted in the housing.

Sealing is provided by 2 O-rings mounted in grooves of the rear axle housing. Each piston is controlled by a master cylinder supplied by a residual oil flow coming from the 17 bar valve or from the distribution block via the manifold (closed centre), according to the version.

Each piston acts directly on a friction disc mounted on the planetary shaft at the entrance of the trumpet housing and a backplate centred by dowels and supported on the ring gear of the final drive unit. When the brake is released, a self-adjusting device fitted as from serial number E275051 ensures a minimal clearance between the piston and the brake disc and maintains a constant pedal travel.

As from serial number E240024, the brake discs are lubricated by an oil flow. This continuous flow from the lift valve (open centre) or from the lubrication system (closed centre) is conveyed to the brake discs via a pipe and a restrictor coupling screwed onto the trumpet housing. The oil circulating between the discs and the pistons lubricates the braking surfaces when they are not in use and cools the brake when they are used.

**Note : A service solution is available for the fitting of the brake disc lubricating system on tractors manufactured prior to serial number E240024.**



## Rear Axle - Brake pistons and seals

6F01.3

### A . Disassembly

#### 6110 to 6170 Tractors

1. Remove the trumpet housing. Carry out operations 1 to 15, chapter 6 C01.A.

#### 6180 and 6190 Tractors

2. Remove the trumpet housing. Carry out operations 1 to 13, chapter 6 C02.A.
3. Remove the disc **(1)**, the planetary shaft **(2)**, the dowel **(3)** (Fig. 1).
4. Remove the backplate **(1)** (trumpet housing interior) (Fig. 2).
5. As from serial number E275051, remove the bolts **(3)** (Fig. 3A) with a locally manufactured socket. Withdraw the piston **(1)** from the housing with a jet of compressed air applied to the connector **(2)** (Fig. 3B).  
**Note : To facilitate access to the connector (2), if necessary, disconnect the economy 4-speed PTO control (if fitted) and rotate the connector.**
6. Remove the O-rings **(1)** and **(2)** on the centre housing and discard them (fig. 4).

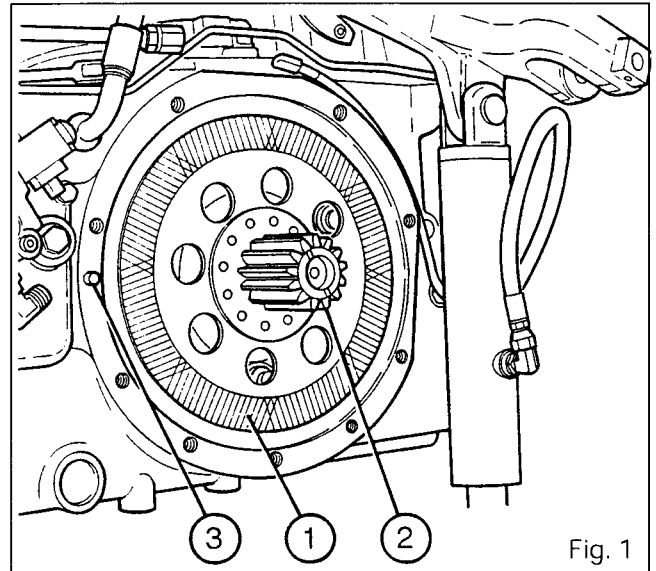

Fig. 1

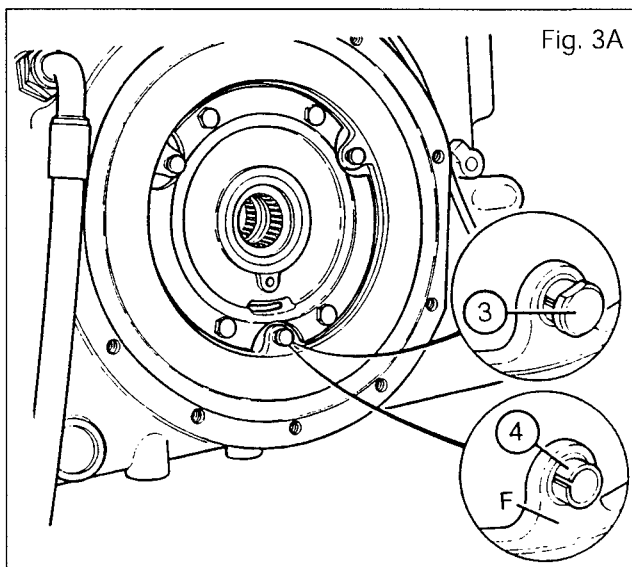
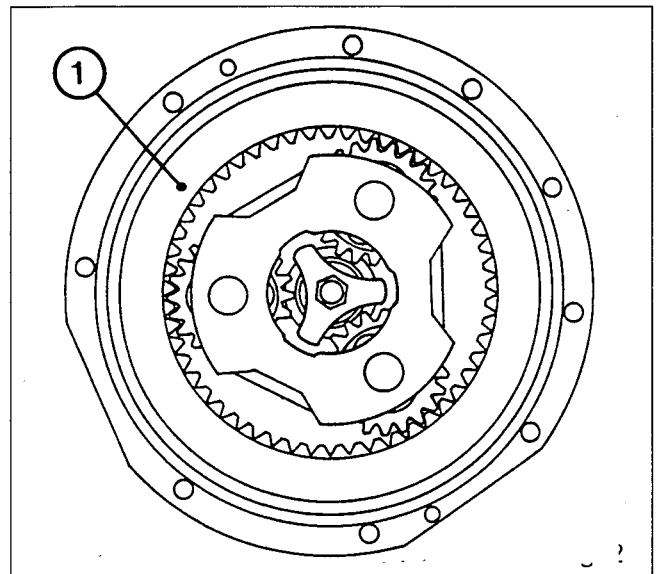

Fig. 3A

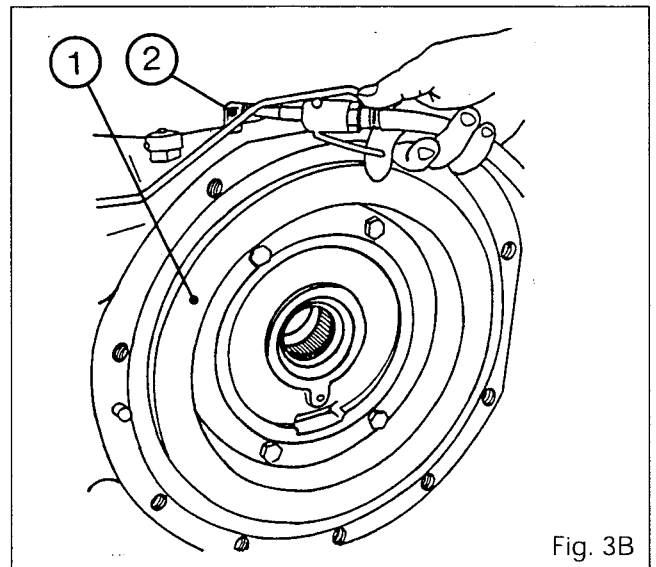

Fig. 3B



6F01.4

# Rear Axle - Brake pistons and seals

## B . Reassembly

7. Clean and check the parts. Replace any which are defective.

**Note :** To ensure that the brake self-adjusting system operates correctly from serial number E275051 to serial number E326018, it is mandatory to centre the RH and LH differential flanges with a locally manufactured tool: see chapter 6C01, parts C and I.

8. Fit the piston (1) without seals in the housing (2) (Fig. 5). Check that the piston slides freely in the bore in the housing and that it fits onto the centring dowels (3) without any friction points. After carrying out this check, remove the piston.

9. Fit spring pins (4) at about 8 mm from machined face "F" of the piston (Fig. 3A). Fit new O-rings (1) and (2) (Fig. 6) after smearing them with a moderate quantity of miscible grease so that they remain at the bottom of the groove.

10. Position the piston over the dowels, then fit it in to place with the aid of a plastic mallet, striking alternate points around the circumference (Fig. 7A). Fit the bolts (3) (Fig. 7B) after lightly smearing them with Loctite 241 and tighten them to a torque of 10 Nm with the locally manufactured socket.

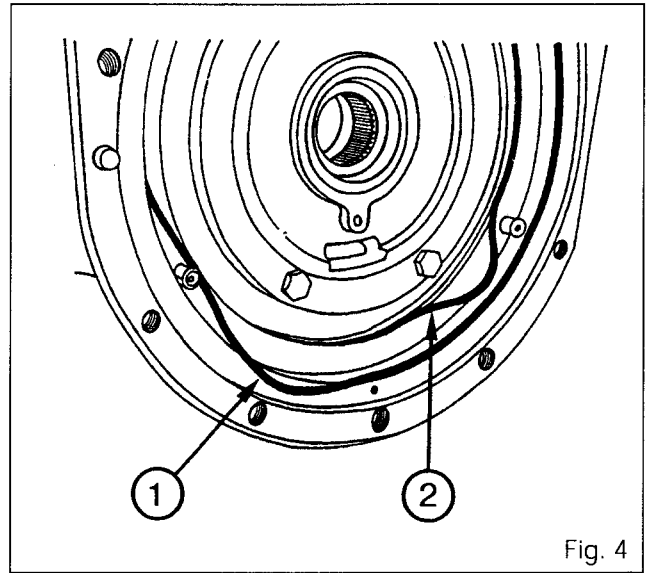

Fig. 4

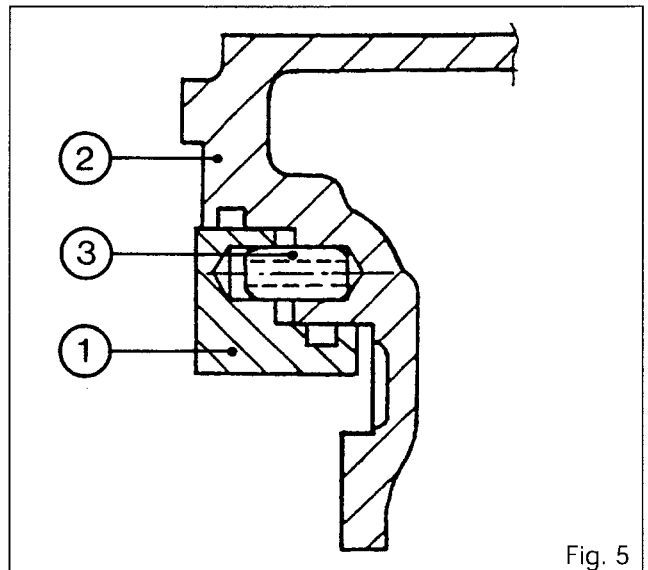

Fig. 5

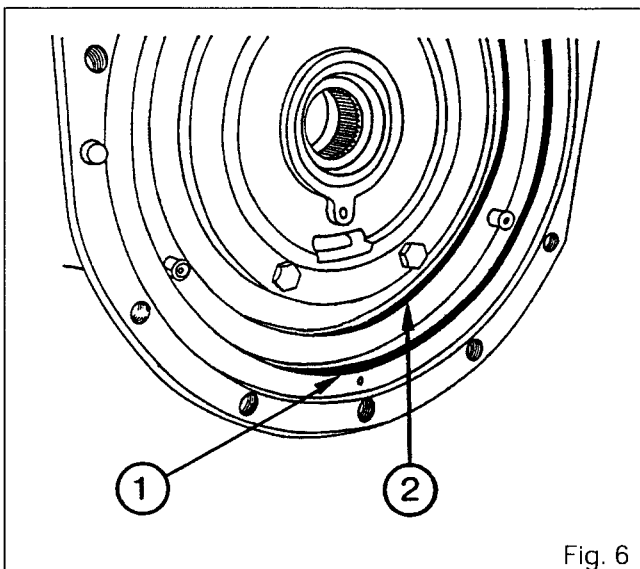

Fig. 6

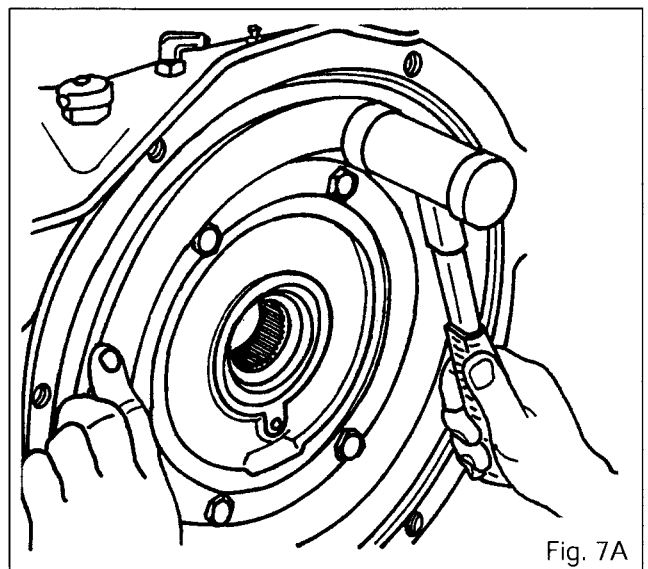

Fig. 7A



## Rear Axle - Brake pistons and seals

11. Hold the piston with two large washers and two screws diametrically opposed (Fig. 8).

### Leak test (operations 12 to 15, Fig. 8).

If work is carried out on the brake piston and O-rings, it is necessary to check for leaks.

12. Fit a pressure gauge to the connector (2).
13. Supply the circuit with compressed air at approx. 5 bar, so as ensure that the piston and O-rings are positioned correctly. Reduce pressure to 0.3 bar to carry out the test.
14. Close the pressure reducing valve. For 1 min. no reduction in pressure should be indicated at the pressure gauge.
15. Disconnect the pressure gauge. Remove the screws and the holding washers. Reconnect the brake hose.

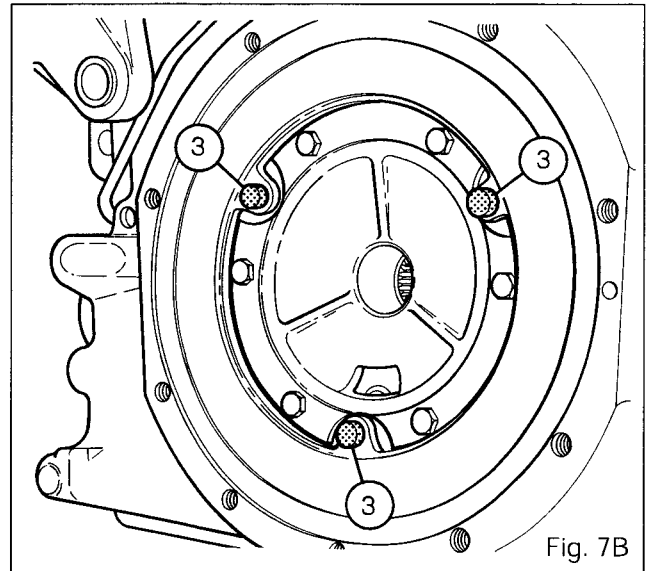

Fig. 7B

### Refitting the trumpet housing (on tractors 6110 to 6170)

16. Clean mating faces on the housing and on the trumpet housing with a non-greasy solvent and carry out operation 19, chapter 6 C01A. Refit the planetary shaft (2), the disc (1) and the dowel (3) (Fig. 1).

**Note: Check that the disc slides freely on the planetary shaft.**

17. Carry out operations 22 to 34, chapter 6 C01.A.

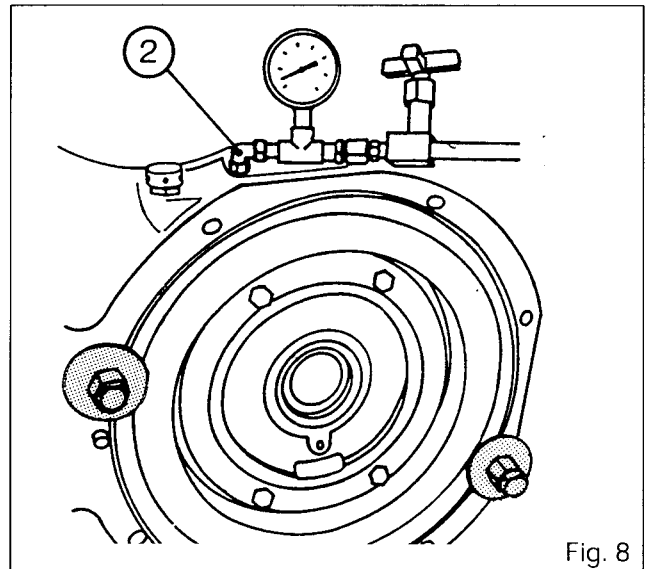

Fig. 8

### Refitting the trumpet housing (on tractors 6180 and 6190)

18. Clean mating faces on the housing and on the trumpet housing with a non-greasy solvent and carry out operation 17 to 31, chapter 6 C02.A.
19. Bleed the main braking circuit and the trailer braking circuit (if fitted), see C and D.
20. Test :
- lifting
  - braking on the road
21. Check for leaks
- between the trumpet housing and the rear axle housing
  - at the lift valve supply hose (open centre) (left hand trumpet housing)

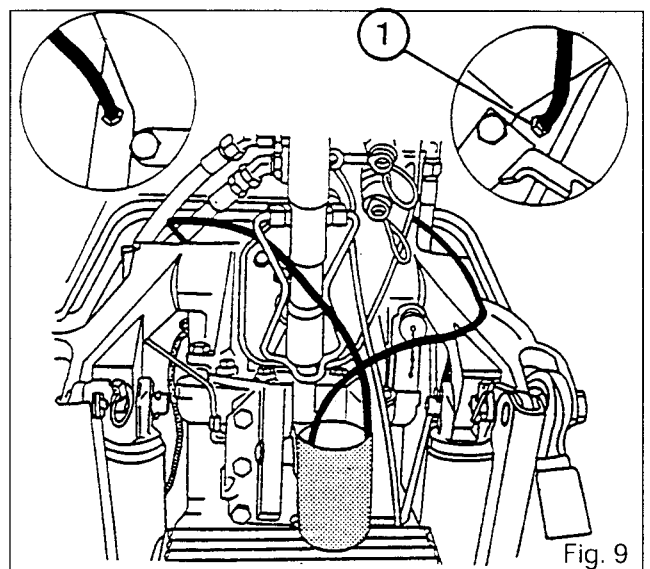

Fig. 9

## C . Bleeding of main braking circuit

22. To each vent screw (1) on the left and right hand of the rear axle housing attach a transparent hose (int. dia. 6 mm) (Fig. 9).



6F01.6

## Rear Axle - Brake pistons and seals

23. Immerse the ends of the two hoses in a container partially filled with transmission oil (Fig. 9).
24. Run the engine at approximately 1,200 rpm. Using suitable protection, clamp the return hose or hoses (1). See the following figures according to the serial number :
  - Fig. 11A: up to serial number D086000 (Std) and D115016 (dipping hood)
  - Fig. 11B: as from serial number D086001 (Std) and D115017 (dipping hood)
  - Fig. 11C: Use the same method and correctly identify the return hose (1) located to the front left-hand side of the gearbox (closed centre hydraulic circuit).
25. Open the right vent screw. Check that there are no leaks between the pipe and the vent screw.
26. Unlock the brake pedals.
27. **Gently** depress the right pedal through its entire travel and release it in the same way. Repeat the operation several times until the oil flows without air bubbles.
28. Close the vent screw.
29. Open the left vent screw. Check that there are no leaks between the pipe and the vent screw.
30. **Gently** depress the left pedal through its entire travel and release it in the same way. Repeat the operation several times until the oil flows without air bubbles.
31. Close the vent screw and release the return hose or hoses.
32. Activate each pedal several times in order to position the brake pistons.
33. Check the hardness of action of each pedal.

**Note : If a problem of functioning should appear, carry out bleeding a second time.**

**If the problem persists, check for leaks :**

- from the circuit
- at the master cylinders
- at the piston seals.

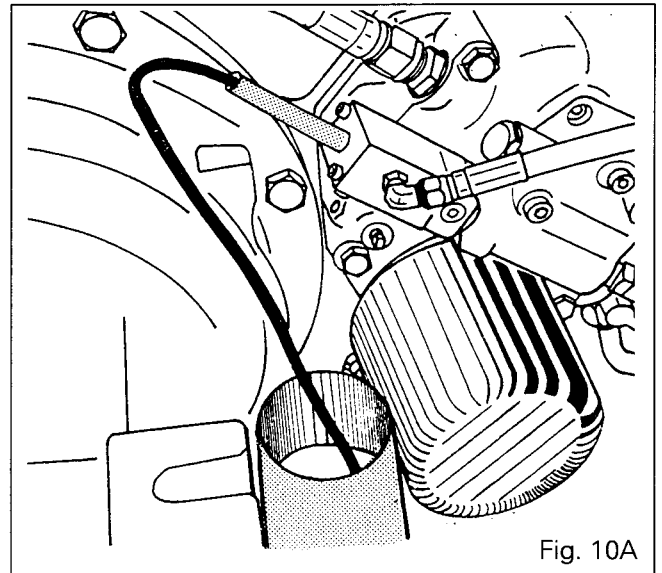

Fig. 10A

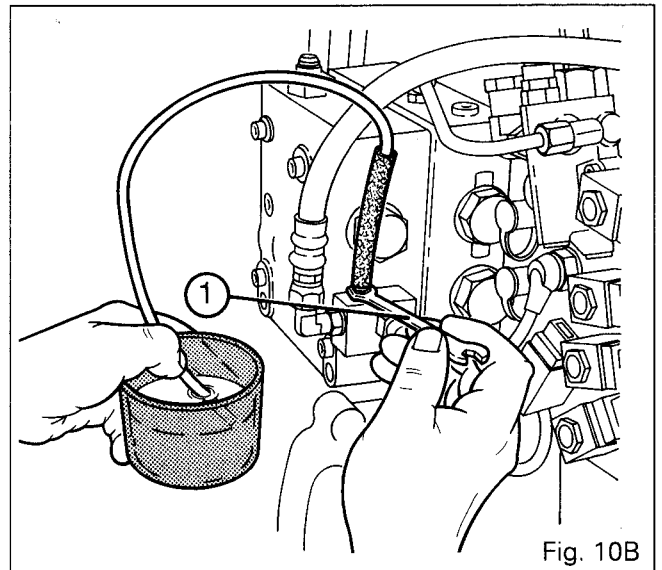

Fig. 10B

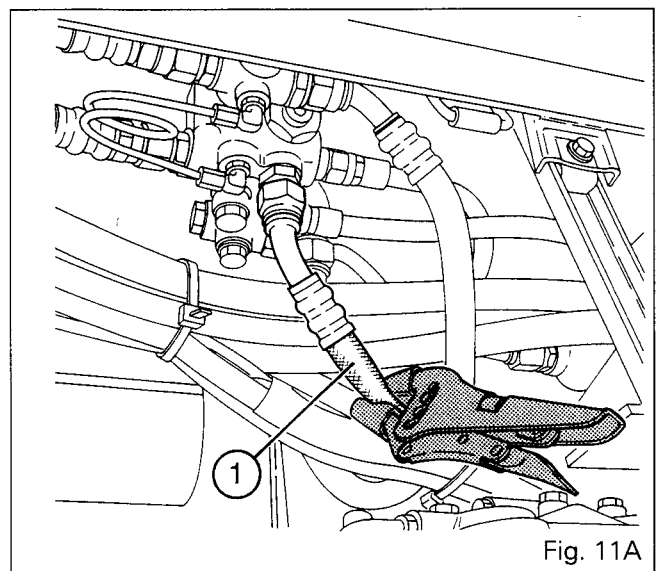

Fig. 11A



## Rear Axle - Brake pistons and seals

### D . Bleeding of trailer braking circuit

**Note :** It is imperative to bleed the main braking circuit before bleeding the trailer braking circuit.

34. Connect a transparent hose (inside dia. 4 mm) onto the vent screw on the pilot head of the trailer brake valve (open centre circuit) or on the distribution block (closed centre circuit) (see Fig. 10A or 10B).
35. Immerse the end of the hose in a container partially filled with transmission oil (Fig. 10A or 10B).
36. Clamp the return hose or hoses and repeat operation 24.
37. Open the vent screw. Check that there are no leaks between the pipe and the vent screw.
38. **Gently** depress the twin pedals. Repeat the operation several times until the oil flows without air bubbles.
39. Close the vent screw and release the return hose or hoses.
40. Connect a pressure gauge to the trailer brake connector (Fig. 12).
41. Run the engine at approx. 2000 rpm.
42. **Gradually** depress the twin brake pedals.
43. The pressure obtained should be between 130 and 150 bar maximum.

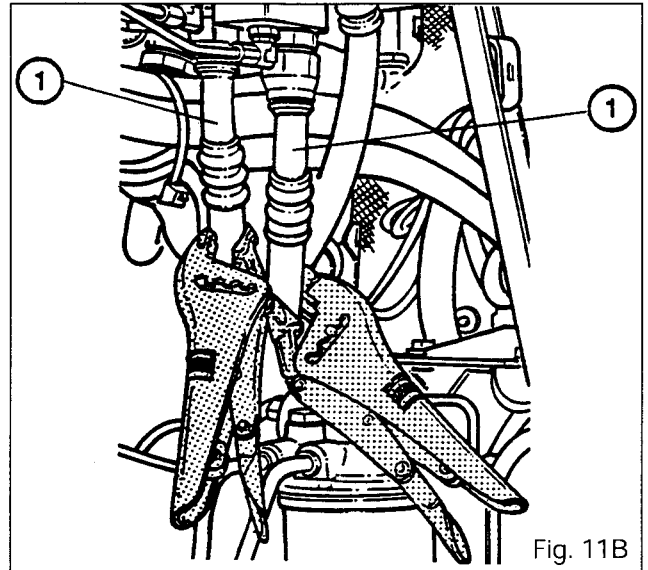

Fig. 11B

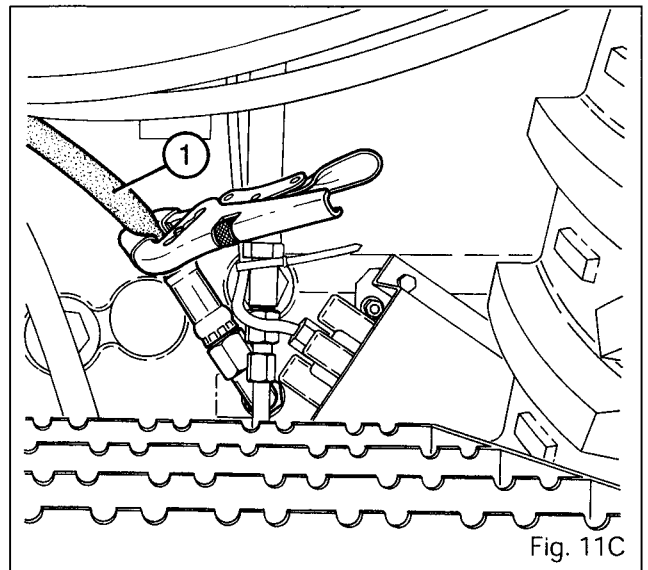

Fig. 11C

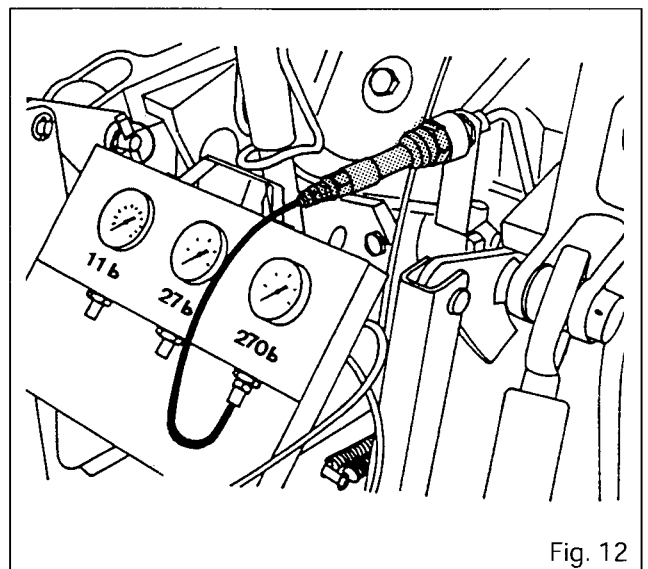

Fig. 12







## **7 . POWER TAKE-OFF**

### **Contents**

- 7 A01 INTERMEDIATE SHAFT - DRIVING PINION - PTO BRAKE**
- 7 B01 REMOVABLE PTO SHAFT**
- 7 C01 SHIFTABLE PTO SHAFT**
- 7 D01 GROUND SPEED PTO**
- 7 E01 PTO CLUTCH**





**Power Take Off - Inter<sup>te</sup> shaft - Driv<sup>ng</sup> pinion - PTO brake**

*7 A01 Intermediate shaft - Driving pinion -  
Power-take-off brake*

CONTENTS

- **General** \_\_\_\_\_ **2**
- **Operation** \_\_\_\_\_ **2**
- A. 2-speed PTO (without shimming)** \_\_\_\_\_ **5**
- B. 2-speed PTO (with shimming)** \_\_\_\_\_ **6**
- C. 4-speed economy PTO (without shimming)** \_\_\_\_\_ **8**
- D. 4-speed economy PTO (with shimming)** \_\_\_\_\_ **10**



## 6100 SERIES TRACTORS

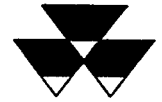

7A01.2

### Power Take Off - Inter<sup>te</sup> shaft - Driv<sup>ing</sup> pinion - PTO brake

#### General

The drive from the engine is transmitted to the power-take-off clutch mounted at the front of the centre housing.

The intermediate shaft (2) is connected by splines at one end to the clutch and at the other end either to the double pinion (13) in the 2-speed PTO version or to the coupler (31) in the 4-speed economy PTO version.

The compound pinion (13) turns on two taper roller bearings (3) (4) and (7) (8), mounted in the bore of the centre housing and the top link support (10) respectively.

A piston (9) housed in the 3rd point support and controlled by the 17 bar hydraulic circuit enables the compound pinion (13) to be braked when the control lever is moved to the PTO braking position.

#### Operation

##### 2-speed PTO

When the PTO solenoid valve feeds the clutch, the intermediate shaft (2) is driven. This in turn drives the compound driving pinion (13) which engages constantly with the 540 rpm and 1000 rpm pinions of the lower line.

##### 4-speed PTO

This feature enables speeds of 540 rpm or 1000 rpm to be obtained with an engine speed of 1550 rpm.

##### Standard position (engine speed 2000 rpm)

When the coupler (31) is moved forwards, the intermediate shaft (2) turns with the shaft (35) which drives the compound driving pinion (13). This configuration is identical to the 2-speed PTO version.

##### Economy position (engine speed 1550 rpm)

When the coupler (31) is moved backwards, the drive is transmitted to the coupler (34) (fitted loose on the shaft (35)) and to the compound pinion (18) which drives the driving pinion (13). The ratio of the compound pinion (18) is 1.292.

##### Power-take-off brake

The knob put in PTO position acts on an electrical contactor which enables the solenoid valve of the PTO brake mounted on the right cover to open. Oil is supplied to the chamber situated behind the piston (9). The piston moves and presses the bearing cup (8) against the bearing cone (7), progressively immobilising the driving pinion (13) which constantly engages with the 540 and 1000 rpm pinions.

#### Power-take-off 4-speed 2-speed

	4-speed	2-speed
(1) Clutch	•	•
(2) Intermediate shaft	•	•
(3) Bearing cup	•	•
(4) Bearing cone	•	•
(5) Washer	•	•
(6) Bolt	•	•
(7) Bearing cone	•	•
(8) Bearing cup	•	•
(9) Brake piston	•	•
(10) Top link support	•	•
(11) Shims	•	•
(12) O-ring	•	•
(13) Driving pinion	•	•
(14) Compound pinion assembly	•	•
(15) Deflector	•	•
(16) Washer	•	•
(17) Needle roller bearing	•	•
(18) Compound pinion	•	•
(19) Spacer	•	•
(20) Needle roller bearing	•	•
(21) Washer	•	•
(22) Set screw	•	•
(23) Shaft	•	•
(24) Locking screw	•	•
(25) Nut	•	•
(26) Fork	•	•
(27) Screw	•	•
(28) Needle roller bearing	•	•
(29) Circlip	•	•
(30) Ring	•	•
(31) Dog tooth coupler	•	•
(32) Circlip	•	•
(33) Washer	•	•
(34) Dog tooth pinion	•	•
(35) Shaft	•	•
(36) Cup plug	•	•



6100 SERIES TRACTORS



Power Take Off - Inter<sup>te</sup> shaft - Driv<sup>ng</sup> pinion - PTO brake

7A01.3

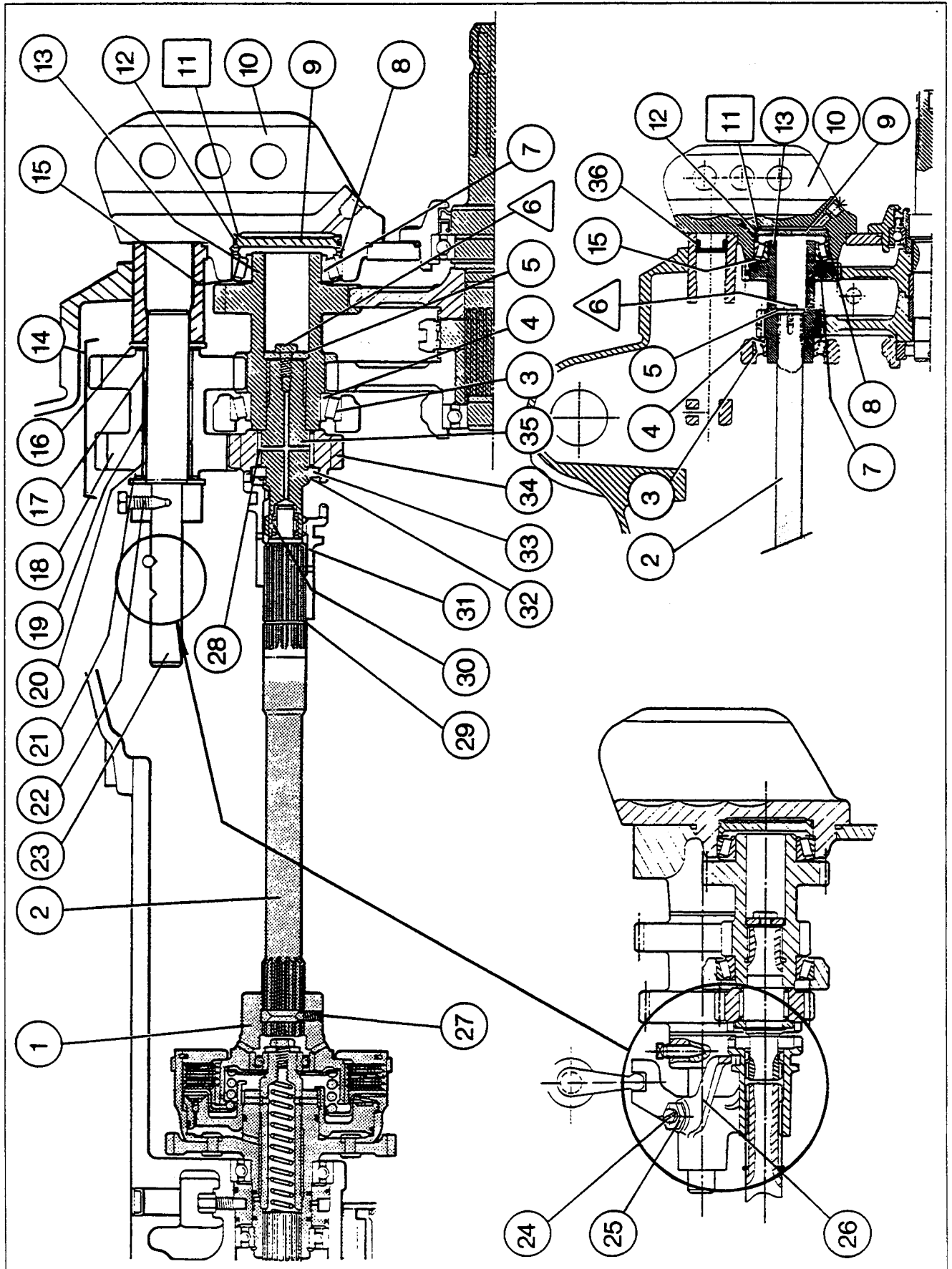



# 6100 SERIES TRACTORS



7A01.4

## Power Take Off - Inter<sup>te</sup> shaft - Driv<sup>ing</sup> pinion - PTO brake

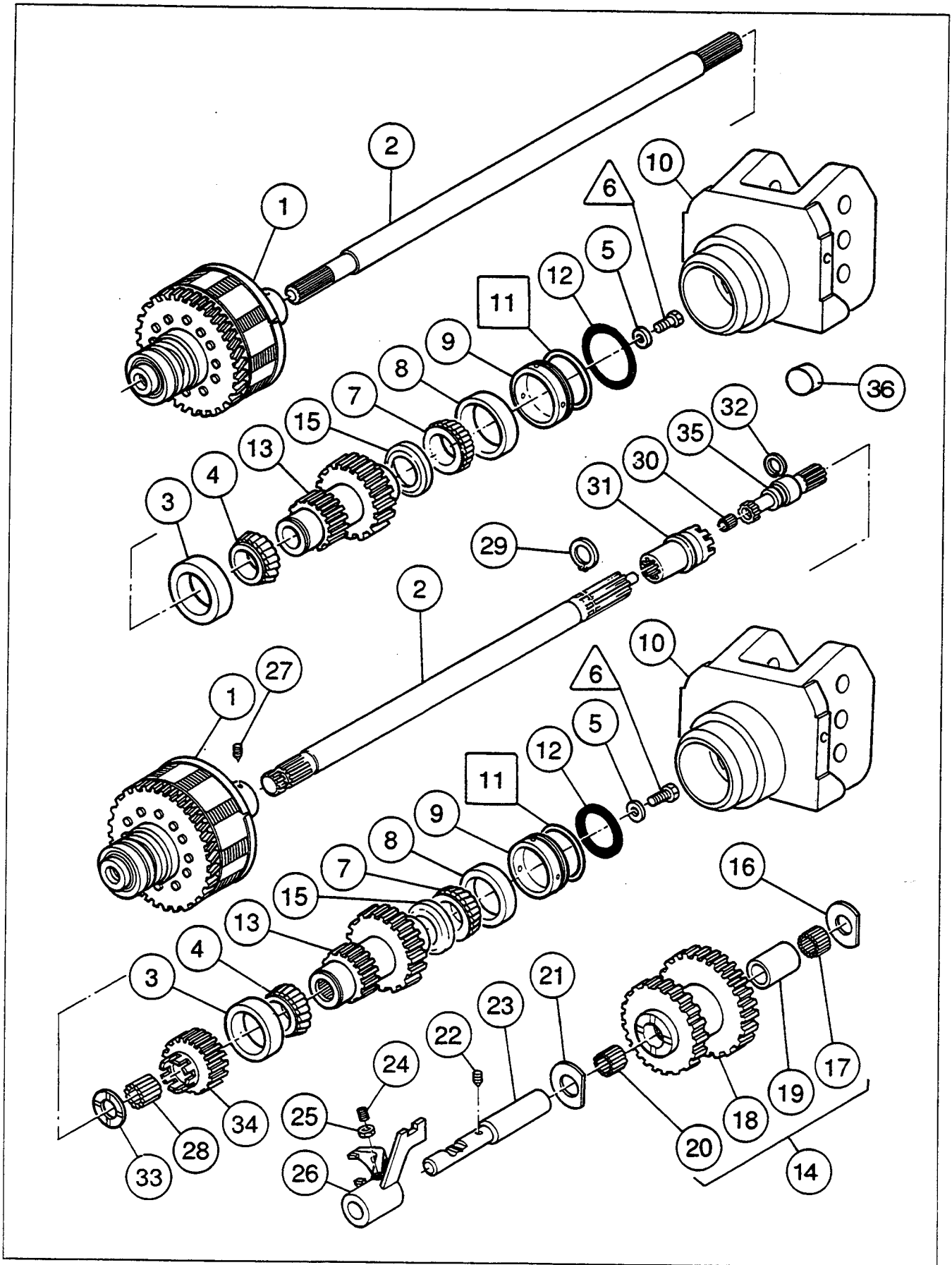



## Power Take Off - Inter<sup>te</sup> shaft - Driv<sup>ng</sup> pinion - PTO brake

7A01.5

### A. 2-speed PTO (without shimming)

#### Disassembly

1. Disconnect (Fig. 1) :
  - . the auxiliary spool valve supply hose (1)
  - . the supply hose of the lift valve (3)
  - . the return hose (2)
2. Remove the bolts (4) of the auxiliary spool valve support (5) (Fig. 1).
3. Detach the auxiliary spool valve support.
 

**Note: Tilt the support and auxiliary spool valve assembly without detaching the control cables (1) (Fig. 2).**
4. Disconnect the supply tube (1) of the PTO brake (Fig. 3).
5. Disconnect the lubrication tube (4) (Fig. 3).
6. Remove the bolts (3) and the top link support (10) (Fig. 3).
7. Withdraw the pinion (13) and shaft (2) assembly held by the washer (5) and screw /6. Remove the bearing cone (4).
 

**Note: The shaft (2) is mounted in the clutch (1) without locking screw.**

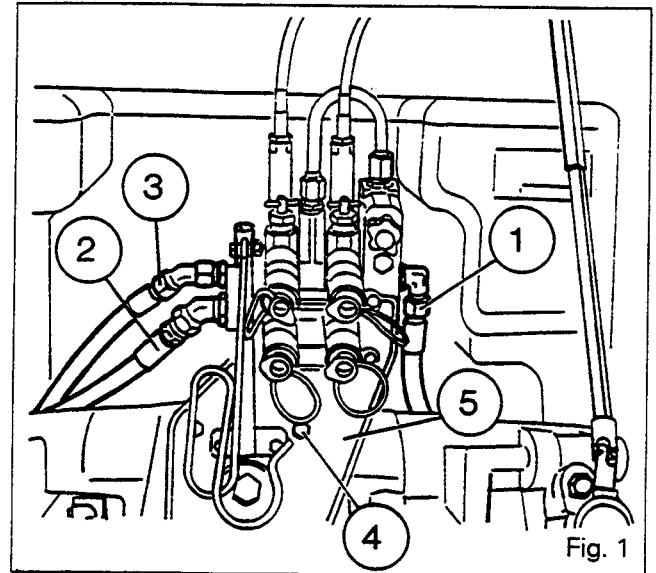

Fig. 1

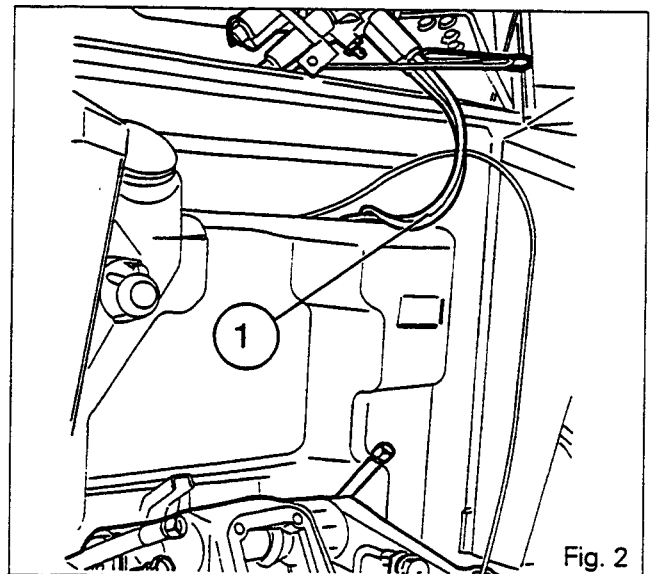

Fig. 2

#### Reassembly

8. Check and clean the parts. Replace those which are defective.
9. Refit the bearing cone (4). Fit the pinion (13) and shaft (2) assembly held by the washer (5) and screw /6.
10. Clean the joint face of the top link support.
11. Smear the joint face of the housing with a sealing compound (Loctite 510 or equivalent).
 

**Note: To ensure the lubrication of the bearing cone (7), a cup plug (36) is fitted without Loctite, recessed into the face of the housing.**
12. Refit the top link support (10). Fit and tighten the bolts (3) to a torque of 130-170 Nm (Fig. 3).
 

**Note: Ensure that the cup (8) is present.**
13. Reconnect the supply tube of the PTO brake (1) and the lubrication tube (4) (Fig. 3).
14. Clean the joint face of the spool valve support.
15. Smear the joint face of the support cover with a sealing compound (Loctite 510 or equivalent).
16. Refit the support, tilting it, with the control cables (1) (Fig. 2).
17. Smear the threads of the two lower bolts (4) with Loctite 510. Fit and tighten the bolts (4) to a torque of 50-70 Nm (Fig. 1).

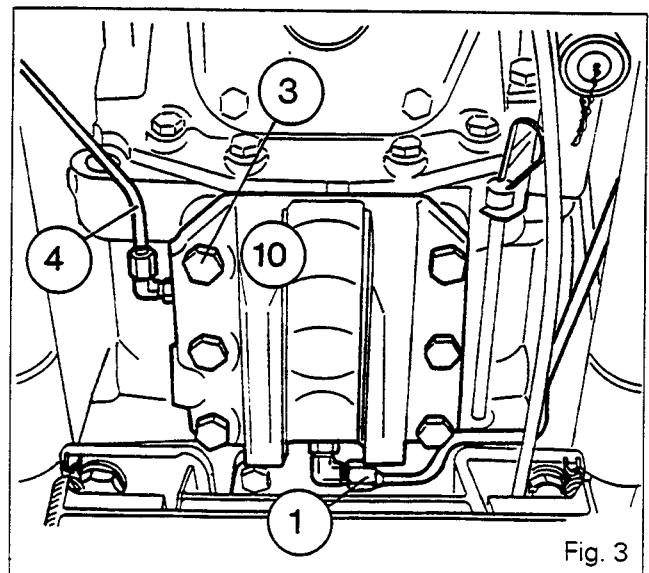

Fig. 3





## 6100 SERIES TRACTORS



7A01.6

### Power Take Off - Inter<sup>te</sup> shaft - Driv<sup>ing</sup> pinion - PTO brake

18. Reconnect (Fig. 1):
  - . the spool valve supply hose (1)
  - . the supply hose of the lift valve (3)
  - . the return hose (2).
19. Check the operation of the PTO and its brake.
20. Check for leaks
  - . at the joint faces (spool valve support, top link support)
  - . at the hydraulic connectors.

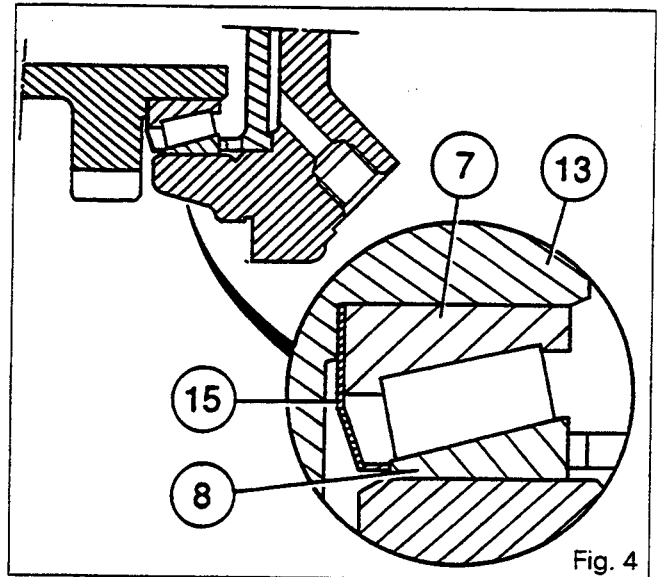

Fig. 4

### B .2-speed PTO (with shimming)

**Note: Shimming J1 must be carried out when working on the following parts: Pinion (13), deflector (15), bearing cones (4) (7), cups (3) (8), piston (9), support (10).**

**For correct shimming of the bearing cones (4) (7) and of the cups (3) (8), it is necessary to remove the lift cover.**

#### Disassembly

21. Remove the lift cover. See section 6B01.
  22. Disconnect the supply tube (1) from the PTO brake (Fig. 3).
  23. Disconnect the lubrication tube (4) (Fig. 3).
  24. Remove the bolts (3) of the top link support (Fig. 3) and detach it.
  25. Withdraw the pinion (13) and shaft (2) assembly held by the washer (5) and bolt /6\.
- Note : The shaft (2) is mounted in the clutch (1) without locking screw.**
26. Remove the screw /6\ and the washer (5).
  27. Separate the pinion (13) from the shaft (2).
- Note : A deflector (15) is mounted between the pinion (13) and the bearing cone (7), in contact with the cup (8) (Fig.4).**
28. Extract the bearing cone (7) and the deflector (15) (Fig. 5), then remove the bearing cone (4).
- Note : To extract the cup (3) it is necessary to remove the 540/1000 rpm pinions. Partly drain the rear axle housing. See section 7 B01.**

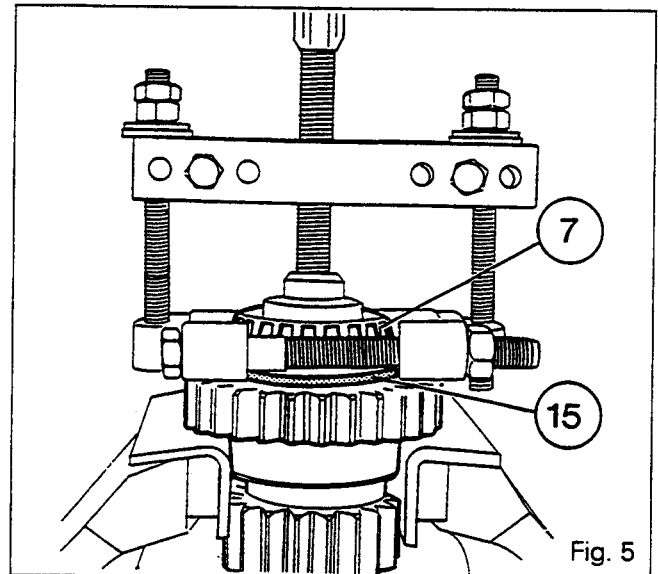

Fig. 5

**Power Take Off - Inter<sup>te</sup> shaft - Driv<sup>ing</sup> pinion - PTO brake**

7A01.7

**Reassembly**

29. Check and clean the parts. Replace those which are defective.
30. Place the deflector (15) on the pinion (13). Push the bearing cone (7) on as far as the shoulder with the aid of a press (Fig. 6).  
Lubricate the bearing cone (4) and place it in the cup (3).
- Note: If replacing the cup (3), refit the 540/1000 rpm pinions. See section 7B01. Top up the oil of the rear axle housing.**
31. Withdraw the piston (9) from the top link support (10).
32. Remove the shims [11] and the O-ring (12) in order to prepare for shimming J1.
33. Fit the piston (9) (without O-ring) and the cup (8) in the support (10).
34. Lubricate the cup and the bearing cone (7).
35. Fit the pinion (13) in the housing.
36. Refit the top link support.  
Tighten the bolts to a torque of 130 - 170 Nm.
37. Carry out shimming (Fig. 7) to obtain :  
**J1 = -0.05 to +0.05.**
38. Place the tip of the dial gauge against the end of the pinion (13) (Fig. 8).
39. Pull on the pinion, turning it alternately from right to left, so as to compress the deflector (15), to seat the bearing cone (7) correctly in the cup (8).
40. Set the dial gauge to zero.
41. Push the pinion, turning it alternately from right to left, to seat the bearing cone (4) correctly in the cup (3).
42. Select shims of the correct thickness as a function of the dial gauge reading so as to obtain clearance of J1.
43. Remove the support (10) and withdraw the cup (8) and piston (9).
44. Place the shims [11] selected in operation 42 in the support (10).

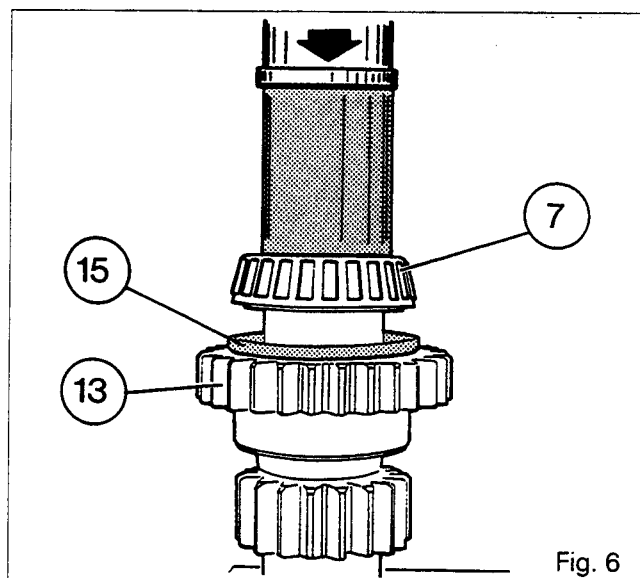

Fig. 6

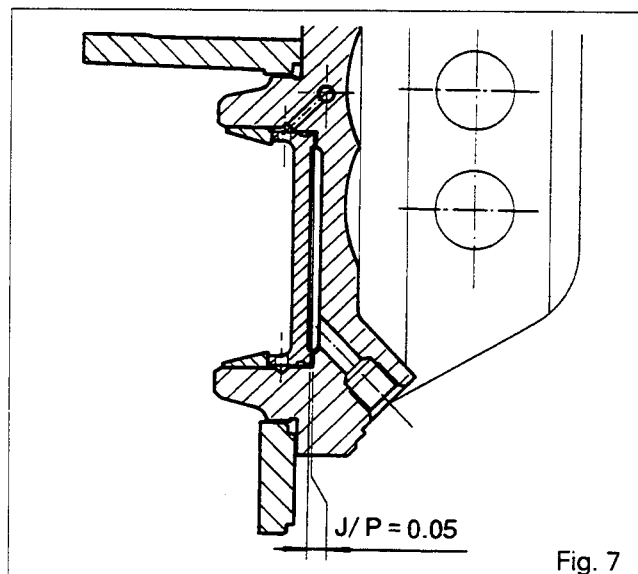

Fig. 7

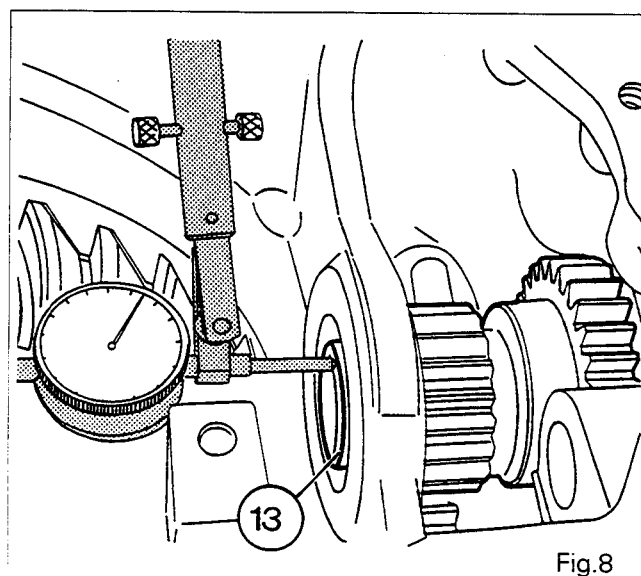

Fig. 8

7A01.8 **Power Take Off - Inter<sup>te</sup> shaft - Driv<sup>ing</sup> pinion - PTO brake**

45. Fit the piston (9) with a new O-ring (12).  
**Note: Position the lubrication holes of the piston toward the bearing cone (Fig. 9).**
46. Fit the cup (8) in the support.
47. Withdraw the pinion (13) and assemble on the shaft (2) with the washer (5) and bolt (6). Tighten to a torque of 50 Nm.
48. Refit the bearing cone (4). Fit the pinion (13) and shaft (2) assembly.
49. Smear the face supporting the top link support on the rear axle housing with a sealing compound (Masterjoint 510 or equivalent).
50. Refit the top link support (10). Fit and tighten the bolts (3) to a torque of 130-170 Nm (Fig. 3).  
**Note: Ensure that the cup (8) is present.**
51. Reconnect the supply tube (1) of the PTO brake and the lubrication tube (4) (Fig. 3).
52. Refit the lift cover. See section 6B01.
53. Check the operation of the PTO and its brake.
54. Check for leaks:
  - . at the joint faces (spool valve support, top link support, lift cover)
  - . at the hydraulic connectors.

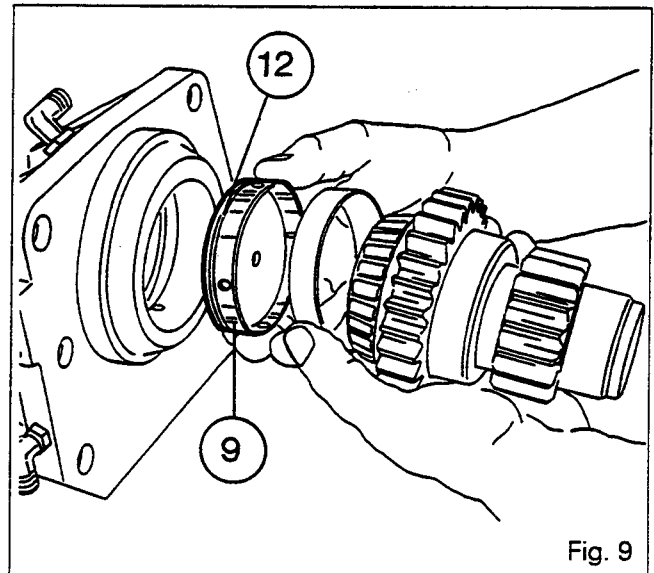

Fig. 9

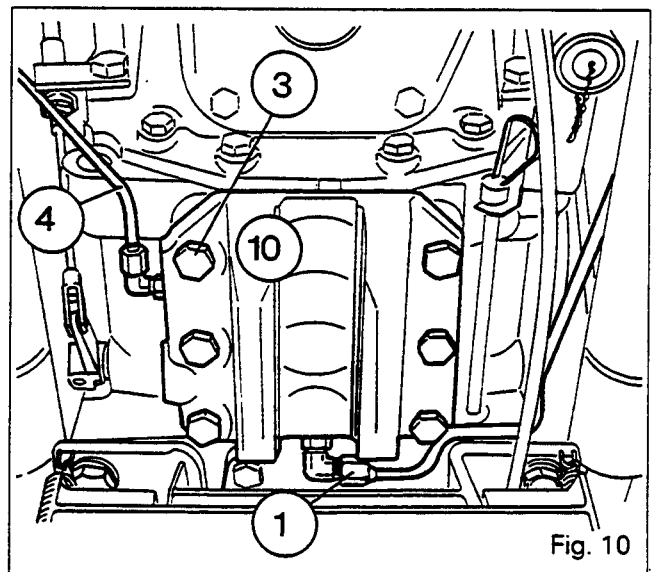

Fig. 10

### C .4-speed economy PTO (without shimming)

#### Disassembly

55. Remove the left side cover.  
If removing the screw (27) and the intermediate shaft (2), carry out operations 1 to 6, section 8I02.
56. Disconnect (Fig. 1):
  - . the spool valve supply hose (1)
  - . the supply hose of the lift valve (3)
  - . the return hose (2).
57. Remove the bolts (4) fastening the support (5) to the lift cover (Fig. 1).
58. Remove the support.  
**Note: Tilt the support and spool valve assembly without detaching the cables (1) (Fig. 2).**
59. Disconnect the supply tube (1) of the PTO brake (Fig. 10).
60. Disconnect the lubrication tube (4) (Fig. 10).
61. Remove the bolts (3) of the top link support (10) and detach it (Fig. 10).
62. Remove nut (25) and locking screw (24) from fork (26).



## Power Take Off - Inter<sup>te</sup> shaft - Driv<sup>ing</sup> pinion - PTO brake

7A01.9

66. Remove the nut (25) and the locking screw (24) of the fork (26).
67. Remove the screw (22) (Fig. 11).
68. Withdraw the shaft (23) from the compound pinion assembly (14) in order to disengage the fork (26).  
**Note : To disengage the fork alone, gently pull the shaft (23) towards the rear.**
69. Remove the friction washers (16) and (21).  
**Note : Take care not to drop the washers in the housing.**
70. Withdraw the compound pinion assembly (14) (through the aperture of the spool valve support for version without shimming only) (Fig. 12).
71. Remove the needle roller bearings (17) and (20) and the spacer (19) of the pinion (18).
72. Remove the circlip (32) (Fig. 13).  
**Note : Use short-handled pliers to facilitate access to the circlip.**
73. Withdraw the pinion (13) and shaft (35) assembly held by the washer (5) and bolt /6.
74. Remove the flat washer (33).  
**Note : Take care not to drop the circlip and the washer in the housing.**  
**Hold the pinion (34) and the needle roller bearing (28).**  
**The bearing cone (4) remains in the cup (3) during removal of the pinion (13).**
75. Remove the pinion (34) and the needle roller bearing (28).
76. Remove the bearing cone (4).
77. Remove the hexagon socket setscrew (27) (if necessary).
78. Withdraw the shaft (2) and the coupler (31) (if necessary).  
**Note : The circlip (29) remains on the shaft (2).**

### Reassembly

79. Clean and check the parts. Replace those which are defective.
80. Refit the shaft (2) and the coupler (31) (if removed).
81. Smear the screw (27) with Loctite 221 and tighten (if removed).
82. Refit the bearing cone (4). Advance the pinion (13) prepared with the shaft (35). Fit the coupler (34), the needle roller bearing (28), the washer (33) and the circlip (32). Push on to the pinion (13). Position the washer (33). Fit the circlip (32).

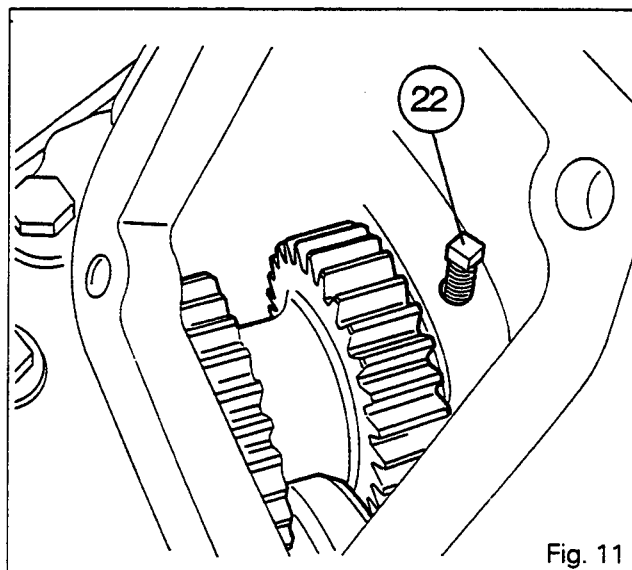

Fig. 11

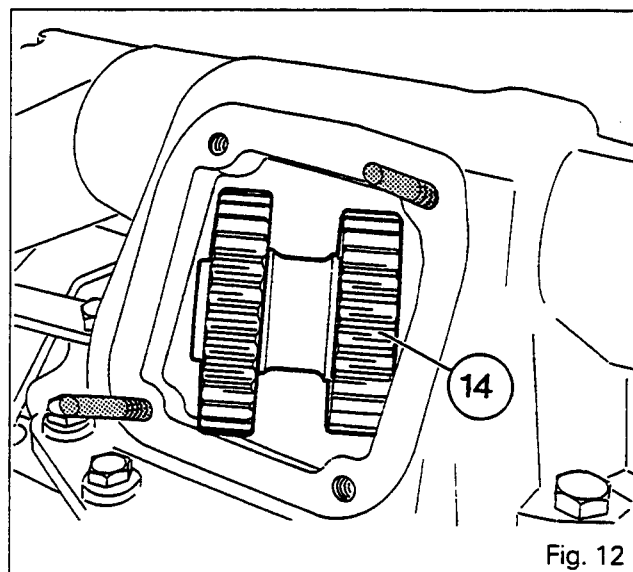

Fig. 12

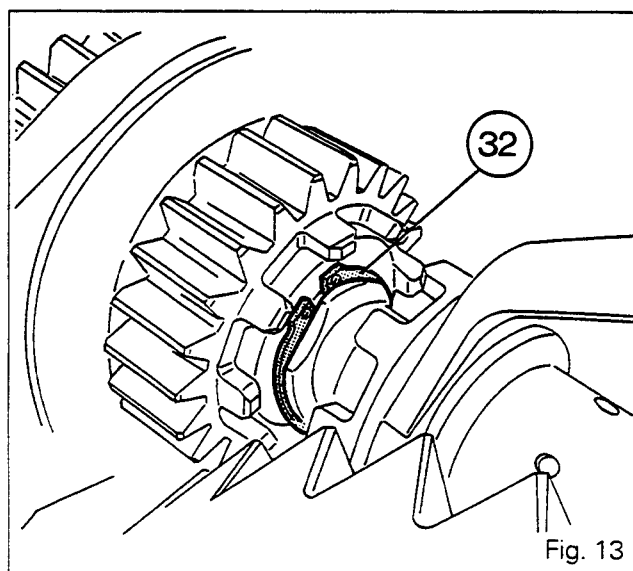

Fig. 13



## 6100 SERIES TRACTORS



### 7A01.10 Power Take Off - Inter<sup>te</sup> shaft - Driving pinion - PTO brake

80. In the pinion (18), place the spacer (19) and the needle roller bearings (17) and (20). Position the compound pinion assembly (14). Fit the washer (16) smeared with miscible grease (Amber Technical or equivalent).
81. Lightly engage the shaft (23) to hold the washer (16) in place. Fit the washer (21) smeared with miscible grease. Centre the compound pinion assembly (14).
82. Mount the shaft (23) finally in the pinion assembly (14) and in the fork (26), ensuring that the hole of the screw (22) is properly positioned.
83. Smear the screw (22) with Loctite 542. Fit and tighten to a torque of 28-43 Nm.
84. Clean the joint face of the top link support.
85. Smear the joint face of the housing with a sealing compound (Loctite 510 or equivalent).
86. Ensure that the cup (8) is present. Fit and tighten the bolts (3) to a torque of 130-170 Nm (Fig. 10).
87. Reconnect the tubes (1) and (4) (Fig. 10).
88. Refit the screw (24) and the nut (25) on the fork (26).
89. **Adjustment of locking of fork (26) (Fig. 14) :**
  - . Position the fork (26) and the locking screw (24) on the flat part M of the shaft (23) (between the two locking notches). Tighten the screw as far as it will go so as to compress the ball.
  - . Loosen the screw by 1/4 of a turn. Smear the nut (25) with Loctite 241. Tighten to a torque of 15-20 Nm.
  - . Check that the fork is locked correctly.
90. Adjust the control. See § E.
91. Clean the joint face of the spool valve support.
92. Smear the joint face of the support with a sealing compound (Loctite 510 or equivalent).
93. Refit the support, tilting it, with the control cables (1) (Fig. 2).
94. Smear the threads of the two lower bolts (4) with Loctite 510. Tighten the four screws to a torque of 50-70 Nm (Fig. 1).
95. Reconnect the hoses (1) (2) (3) (Fig. 1).
96. If the screw (27) and intermediate shaft (2) have been removed, refit the left side cover. Carry out operations 7 to 20, section 9I02.
97. Check the operation of the PTO and its brake.
98. Check for leaks
  - . at the joint faces (spool valve support, top link support, left side cover)
  - . at the hydraulic connectors.

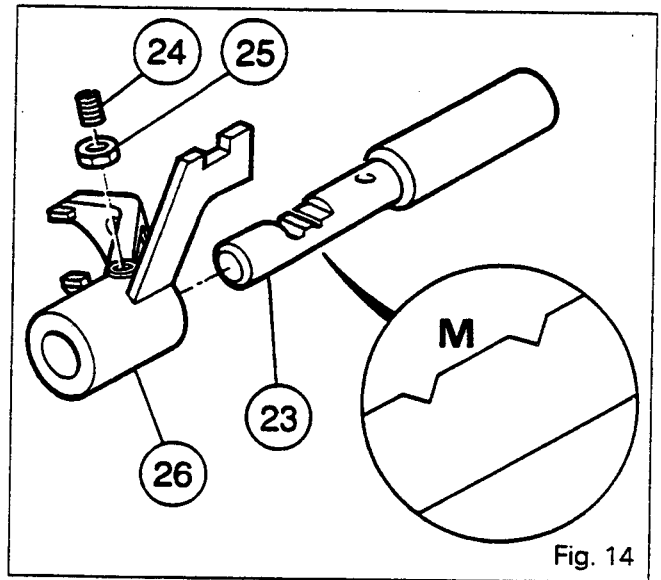

### D .4-speed economy PTO (with shimming)

**Note: Shimming J1 must be carried out when working on the following parts: Pinion (13), deflector (15), bearing cones (4) (7), cups (3) (8), piston (9), top link support (10).**

**For correct shimming of the bearing cones (4) (7) and of the cups (3) (8), it is necessary to remove the lift cover.**

#### Disassembly

99. Remove the lift cover. See section 6 B01.
100. Remove the PTO gears. Carry out operations 59 to 72.

**Power Take Off - Inter<sup>te</sup> shaft - Driv<sup>ing</sup> pinion - PTO brake**

7A01.11

101. Separate the pinion (13) from the shaft (35) with the aid of a press and a suitable tool (Fig. 15).  
**Note: The friction ring (30) is force-fitted in the shaft (35).**
102. Extract the bearing cone (7) and the deflector (15) (Fig. 5).  
**Note: To extract the cup (3) it is necessary to remove the 540/1000 rpm pinions.**  
**Partly drain the axle housing.**  
**Carry out operations 21 to 24, 2 to 6 and 26 of section 7C01.**

**Reassembly**

103. Check and clean the parts. Replace those which are defective.  
**Note : To obtain correct lubrication of the friction ring (30), a deflector (15) (mounted between the pinion (13) and the bearing cone (7) in contact with the cup (8) (Fig. 16).**
104. Place the deflector (15) on the pinion (13). Push the bearing cone (7) on as far as the shoulder with the aid of a press (Fig. 6). Place the bearing cone (4) in the cup (3).  
**Note: If replacing the cup (3), refit the 540/1000 rpm pinions. Carry out operations 31 and 32, 7 to 10 and 34 to 37, section 7C01.**  
**Top up the oil of the rear axle housing.**
105. Carry out operations 31 to 46 to shim gear (13).
106. Withdraw the pinion (13) and assemble on the shaft (35) (Fig. 17). Mount the washer (5) and bolt /6\ . Tighten to a torque of 50 Nm.
107. Refit the bearing cone (4), the coupler (34) and the needle roller bearing (28).
108. Fit the pinion (13) and shaft (35) assembly.  
**Note: Ensure that the coupler (31) is present.**
109. Position the washer (33). Fit the circlip (32).
110. In the pinion (18), place the spacer (19) and the needle roller bearings (17) and (20). Position the compound pinion assembly (14). Fit the washer (16) smeared with miscible grease (Amber Technical or equivalent).
111. Lightly engage the shaft (23) to hold the washer (16) in place. Fit the washer (21) smeared with miscible grease. Centre the compound pinion assembly (14).

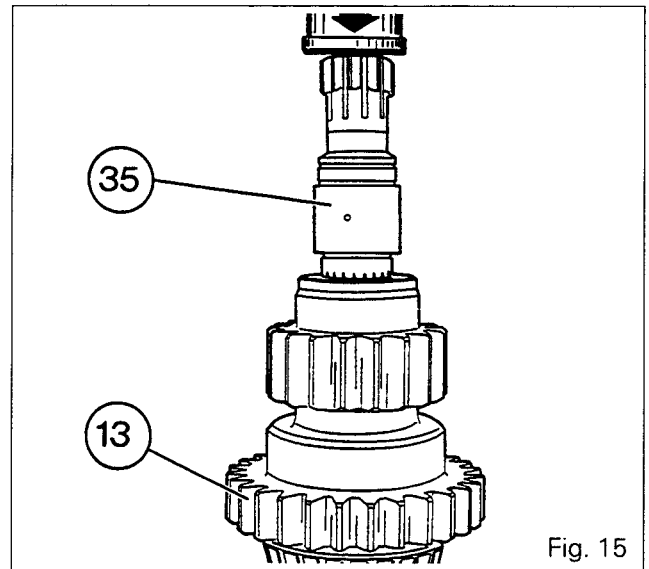

Fig. 15

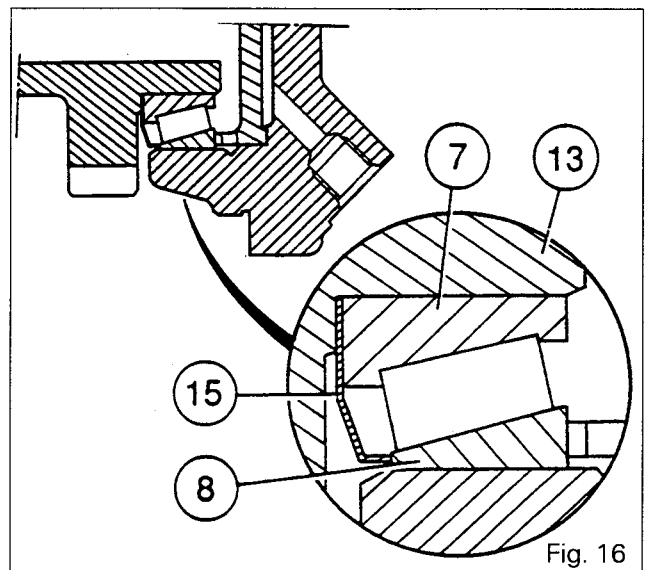

Fig. 16

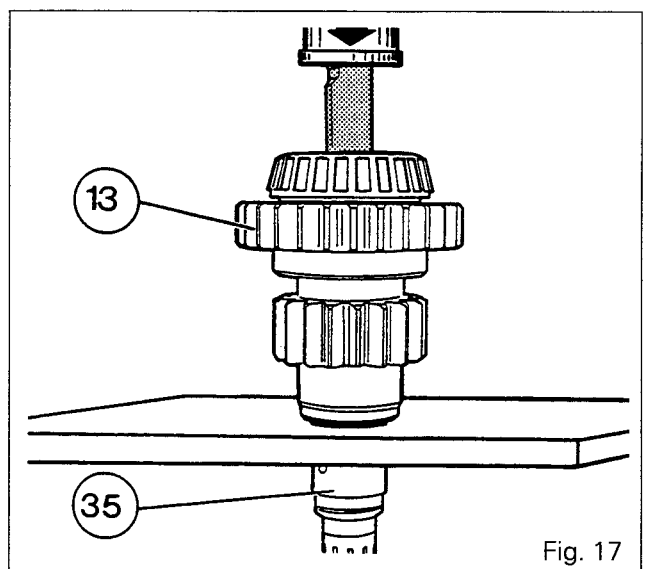

Fig. 17



## 7A01.12 Power Take Off - Inter<sup>te</sup> shaft - Driv<sup>ing</sup> pinion - PTO brake

112. Fit the shaft **(23)** finally in the pinion assembly **(14)** and in the fork **(26)**, ensuring that the hole of the screw **(22)** is properly positioned.
113. Smear the screw **(22)** with Loctite 542. Fit and tighten to a torque of 28-43 Nm.
114. Clean the joint face of the top link support.
115. Smear the joint face of the housing with a sealing compound (Loctite 510 or equivalent).
116. Ensure that the cup **(8)** is present. Fit the top link support with the bolts **(3)** and tighten to a torque of 130-170 Nm (Fig. 10).
117. Reconnect the tubes **(1)** and **(4)** (Fig. 10).
118. Fit the locking screw **(24)** and the nut **(25)**. Adjust the fork **(26)**, carry out operation 88.
119. Refit the lift cover. See section 6B01.
120. Adjust the economy PTO control, see § E.
121. Check the operation of the PTO and its brake.
122. Check for leaks:
  - . at the joint faces (spool valve support, top link support)
  - . at the hydraulic connectors.

### E. Fitting and adjusting the control cable - 4 economic speeds

123. Put the control lever **L** (Fig. 18) into the «Economic - 1550 r.p.m.» position (Fig. 19).
124. Screw the clevis **(1)** to the end of the cable thread **(6)**.
125. Attach the clevis **(1)** to the lever **L** with the clip **(7)**. Tighten the nut **(2)**.
126. Adjust the cable stop **(5)**, the nut **(3)** to the end of the thread.
127. Tighten the nut **(4)**, checking that the cable is not restricted.
128. Put the lever **M** into the «Economic-1550 r.p.m.» position **(a)** as in Fig. 20 (stop in contact with the compound pinion, fork locked)
129. Screw on the clevis **(1)** to the end of the cable thread **(6)** and attach it to the lever **M** with the clip **(7)**. Tighten the nut **(2)**.
130. Adjust the cable stop **(5)**, ensuring that the lever **M** remains locked.
131. Tighten the nuts **(3)** **(4)**, checking that the cable is not restricted.
132. Test the locking mechanism of the lever in the position 2000 r.p.m. **(b)** and verify that the dashboard indicator operates correctly.

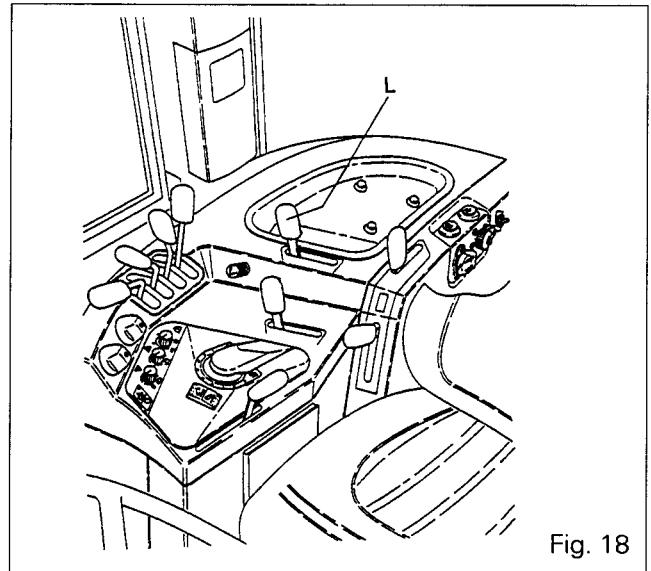

Fig. 18

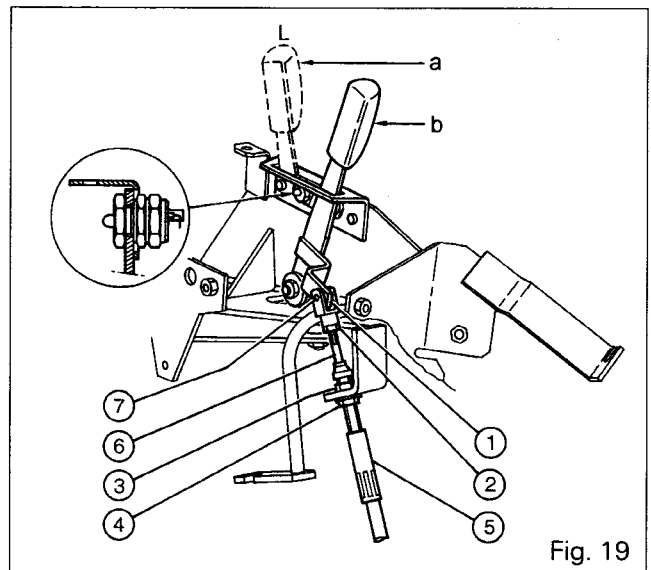

Fig. 19

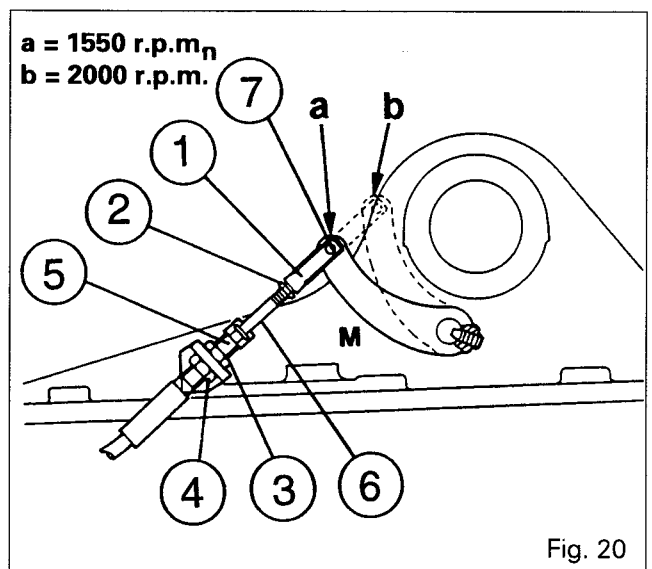

Fig. 20



**Power Take Off - Removable PTO shaft**

*7 B01 Removable PTO shaft*

CONTENTS

- <b>General</b> _____	2
<b>A. Replacement of 540 or 1000 rpm shaft</b> _____	5
<b>B. Removal and refitting of rear cover</b> _____	5
<b>C. Disassembly and reassembly of rear cover</b> _____	6
<b>D. Disassembly and reassembly of 540 and 1000 rpm gear and of front bearing</b> _____	7





7B01.2

---

**6100 SERIES TRACTORS**

---

**Power Take Off - Removable PTO shaft**



---

**General**

---

The driven gears **(5)** and **(6)** are fitted on the PTO shaft situated in the lower rear part of the axle housing. These gears constantly engage with the driving compound gear which is driven by the upper shaft whose movement is transmitted by the PTO clutch.

The PTO shaft **(10)** is fitted at the front on a roller bearing **(1)** force-fitted in the axle housing and at the rear on a hub **(9)** turning on a roller bearing **(15)**.

It has 6 splines in the 540 rpm version and 21 splines in the 1000 rpm version.

In the 540 rpm configuration, the gear **(5)** is driven through the splines of shaft **(10)**. The gear **(6)** and bush **(4)** assembly runs idle on the shaft **(10)**.

In the 1000 rpm configuration, the gear **(6)** is driven via the splines of shaft **(10)**. The gear **(5)** and shaft **(3)** assembly runs idle on the shaft **(10)**.

The snap ring **(20)** holds the shaft in place.

Sealing is provided by the seal **/14\** or **/14A\** and the O-rings **(11)** and **(19)**. The deflector **(13)** ensures protection against foreign material.

**Parts list**

- (1)** Roller bearing
- (2)** Deflector
- (3)** Bush
- (4)** Bush
- (5)** 540 rpm gear
- (6)** 1000 rpm gear
- (7)** Circlip
- (8)** Snap ring
- (9)** Hub
- (10)** 540 or 1000 rpm p.t.o. shaft
- (11)** O-ring
- (12)** Cover
- (13)** Deflector
- /14\** Sealing ring
- /14A\** Reinforced sealing ring
- (15)** Roller bearing
- (16)** Bolt
- (17)** PTO speed sensor
- (18)** Nut
- (19)** O-ring
- (20)** Snap ring



6100 SERIES TRACTORS



Power Take Off - Removable PTO shaft

7B01.3

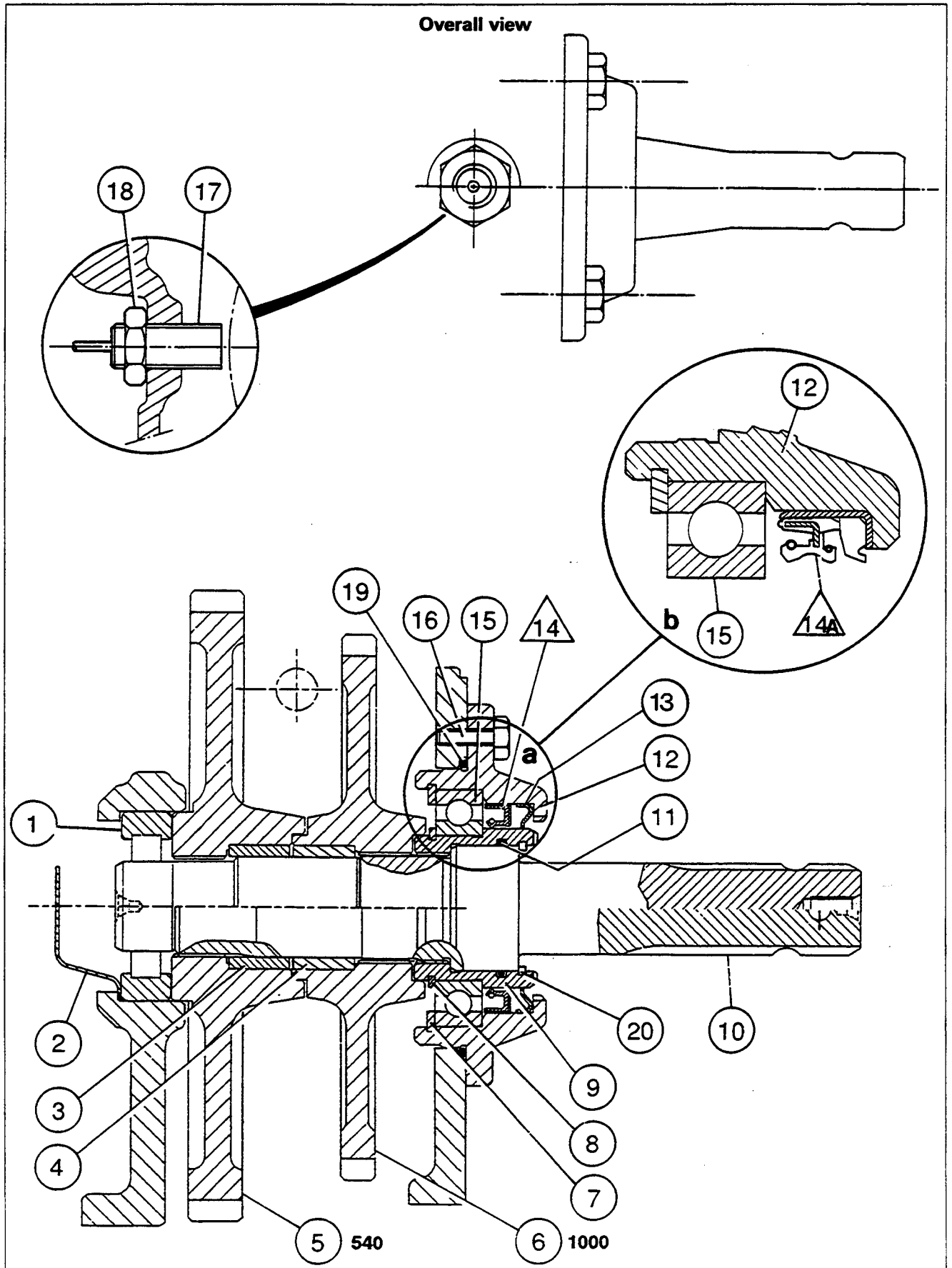



7B01.4

6100 SERIES TRACTORS



Power Take Off - Removable PTO shaft

Exploded view

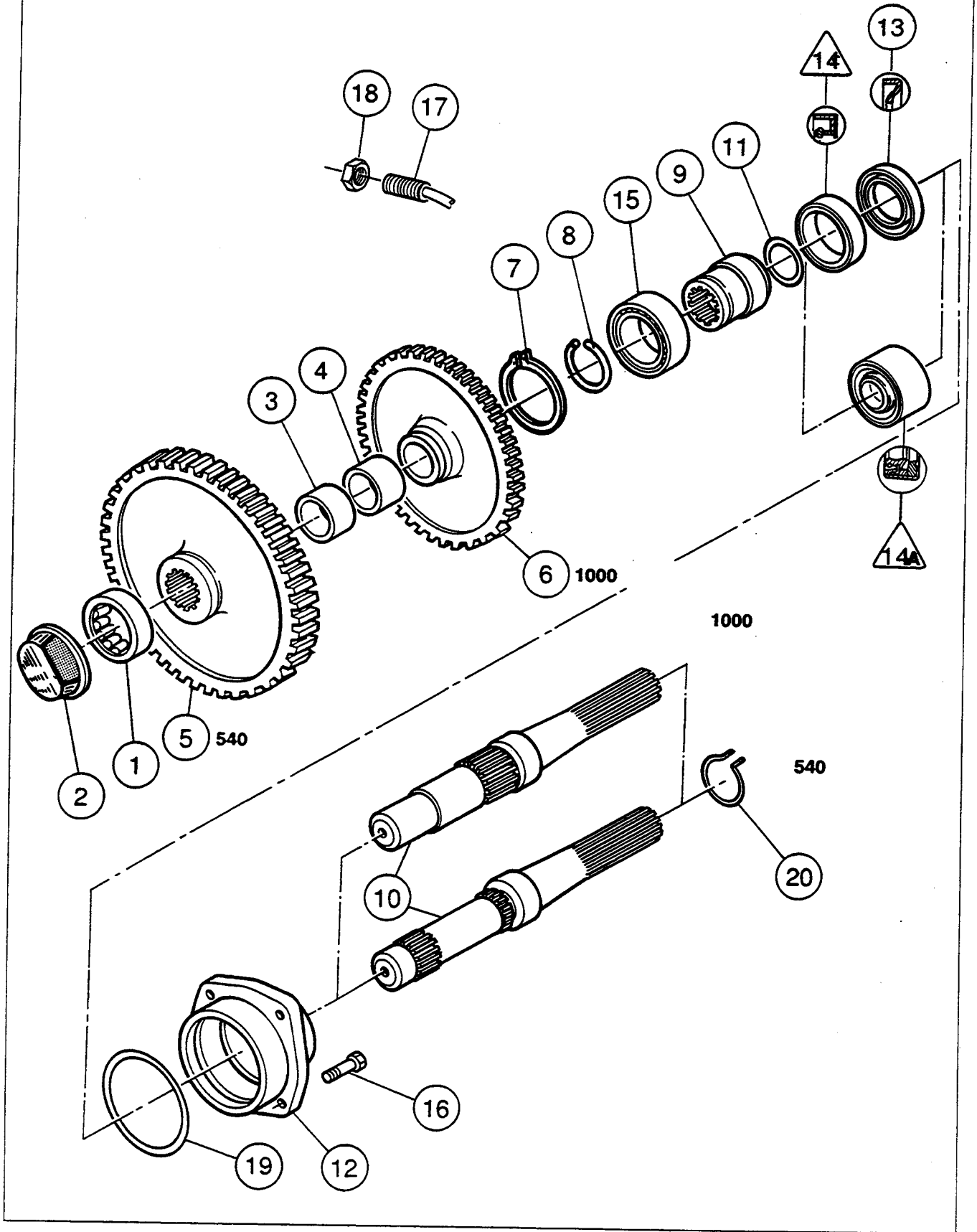



## Power Take Off - Removable PTO shaft

### A . Replacement of 540 or 1000 rpm shaft

#### Disassembly (Fig. 1)

1. Raise rear of tractor to avoid oil spillage.
2. Remove snap ring (20).
3. Withdraw shaft (10).
4. Remove O-ring (11) and discard it.

#### Reassembly

5. Fit a new O-ring (11).
6. Clean and refit shaft (10).
7. Refit snap ring (20) and lower rear of tractor.

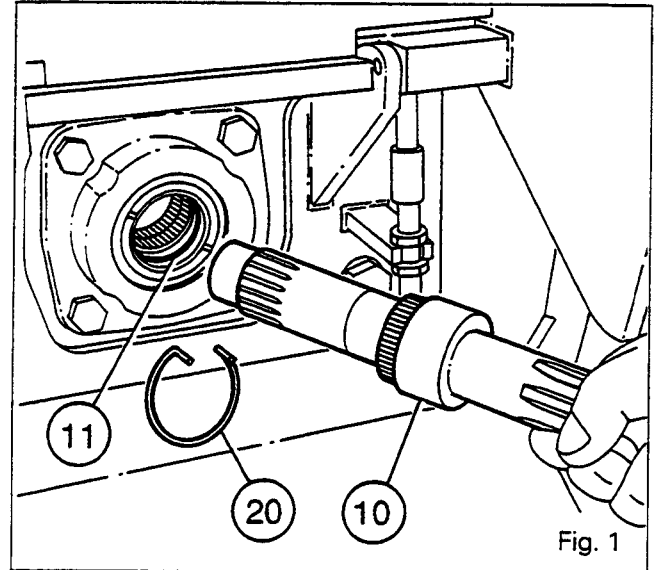

Fig. 1

### B . Removal and refitting of rear cover

#### Removal

8. Partially drain the rear axle housing. Remove two diametrally opposed bolts (16) (Fig. 2).
9. Screw two guide studs (Fig. 2) against the gear (6). The purpose of this is to hold the gears (5) and (6) in line when removing the shaft (10) and the rear cover assembly (Fig. 3).
10. Remove the other two bolts (16) (Fig. 2).
11. Withdraw the shaft and bearing assembly (Fig. 4).

#### Refitting

12. Mount the shaft and rear bearing assembly (Fig. 4).

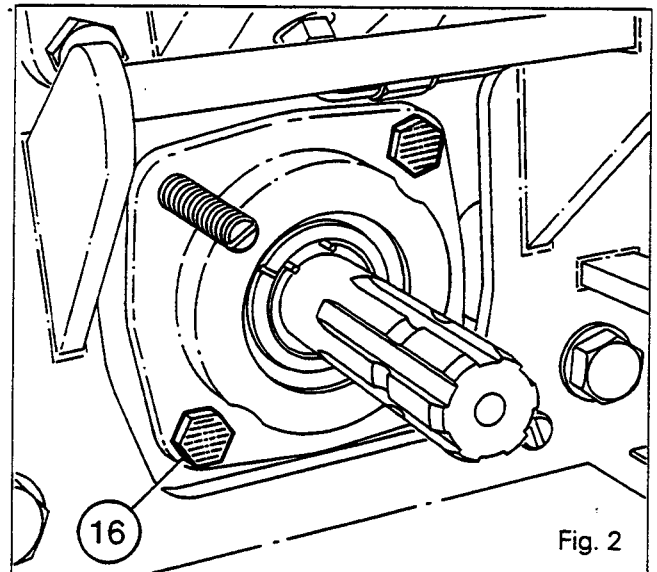

Fig. 2

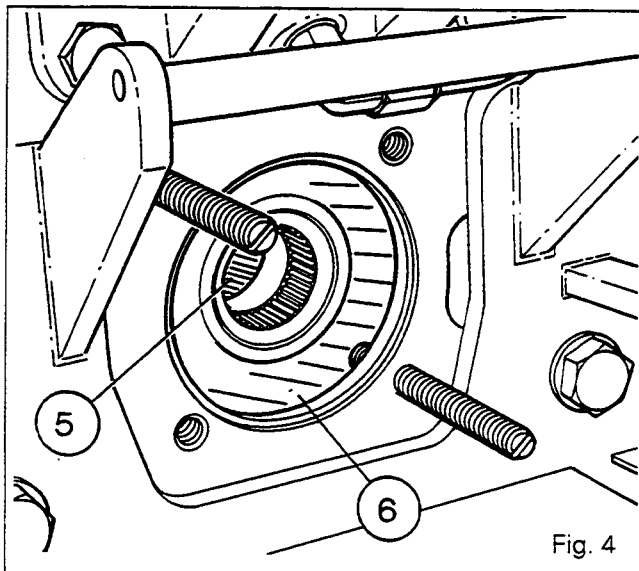

Fig. 4

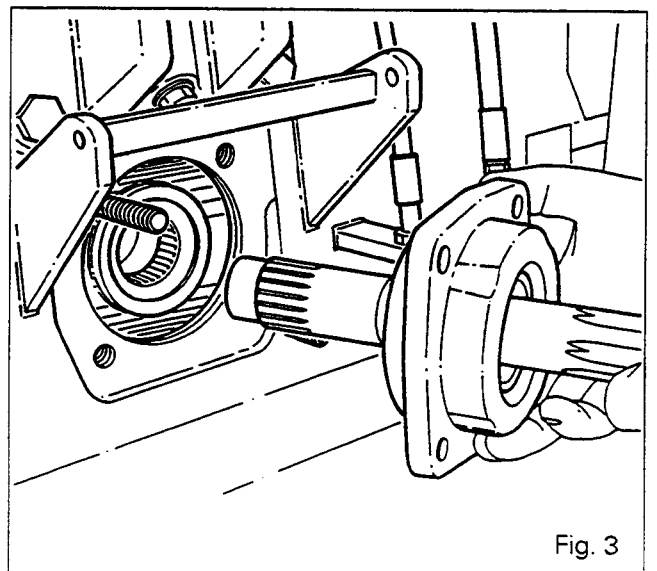

Fig. 3



7B01.6

## 6100 SERIES TRACTORS

**Power Take Off - Removable PTO shaft**

13. Smear Loctite 542 on two bolts (16) then tighten to a torque of 105 - 120 Nm.
14. Remove the two guide studs.
15. Smear Loctite 542 on the other two bolts (16) then tighten to a torque of 105 - 120 Nm.
16. Top up the oil level of the rear axle housing.

### C. Disassembly and reassembly of rear cover

Remove the rear bearing by carrying out operations 8 to 11.

#### Disassembly

17. Remove O-ring (19).
18. Remove snap ring (20).
19. Separate the shaft (10) from the bearing assembly.
20. Remove O-ring (11).
21. Remove circlip (7).
22. Separate the cover (12) from the roller bearing (15).
23. Remove snap ring (8).
24. Extract the roller bearing (15) from the hub (9).
25. Dismantle :
  - version a : the sealing ring /14\ and the deflector (13).
  - version b : the reinforced sealing ring /14A\.

#### Reassembly

##### Version a (Fig. 5)

26. Using a press and a suitable device, fit the deflector (13) against the shoulder of the cover (12).  
**Note: Assemble in the correct way.**
27. Using a press and a suitable device, fit the sealing seal ring /14\ flush with the chamfer of the cover (12) with the lip facing towards the bearing (15).

##### Version b (Fig. 6)

Depending on the option, a reinforced sealing ring /14A\ is fitted in place of the seal /14\ and deflector (13). Smear Loctite 542 on the exterior of the sealing ring and using a suitable device, fit it against the shoulder of the cover (12). The double lip should face towards the bearing (15).

28. Reverse operations 17 to 24 and refit the rear bearing assembly by carrying out operations 12 to 15.

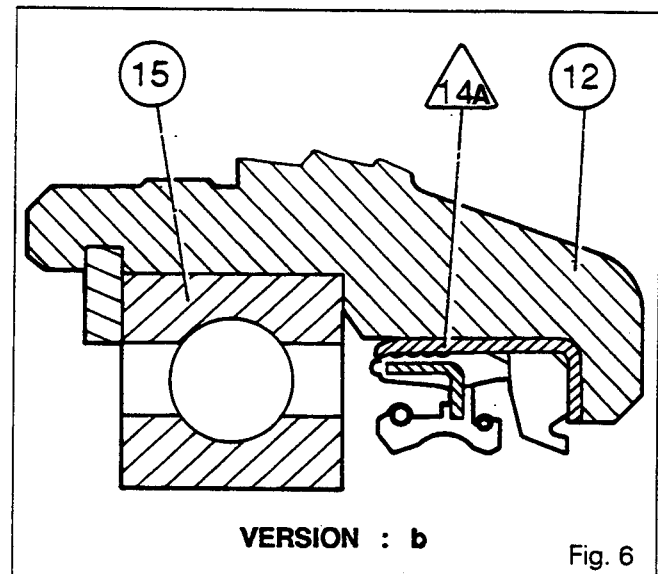
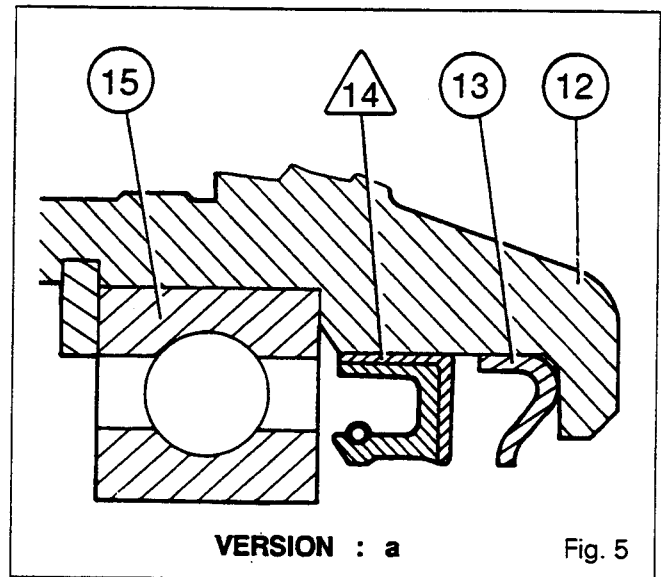



## Power Take Off - Removable PTO shaft

### D . Disassembly and reassembly of 540 or 1000 rpm gear and of front bearing

#### Disassembly

To disassemble gears (5) and (6) it is necessary to remove :

- The lift cover by carrying out operations 1 to 11, section 6 B01.
  - The top link support, the driving gear and the intermediate shaft by carrying out operations 4 to 7, section 7 A01.
29. In order to gain access to the sensor, remove the left cylinder by dismantling the lower fastening and disconnecting the supply hose.  
Remove the PTO sensor (Autotronic - Datatronic).
  30. Remove the rear cover assembly by carrying out operations 8 to 11.
  31. Remove the gears (5) and (6).
  32. Extract the bearing (1) and the deflector (2).

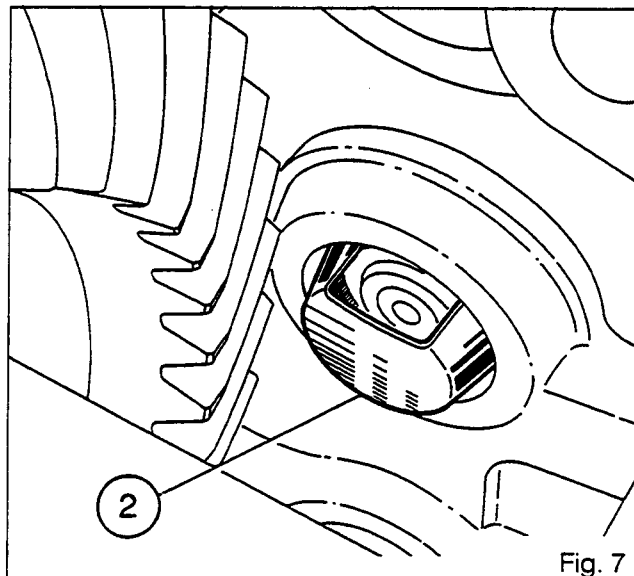

#### Reassembly

33. Clean and check the parts. Replace those which are defective.
34. Smear Loctite 648 on the face of the deflector (2) which meets the housing and place it in its hole. Position so that the aperture faces upward (Fig. 7).
35. Fit the roller bearing (1) in the housing abutting on the deflector (2).
36. Lubricate the bushes (3) and (4).
37. Refit the gears (5) and (6) and screw two guide studs against the gear (6). The purpose of this is to hold the gears in line (Fig. 3) when refitting the rear cover assembly.  
**Note: If the bushes (3) and (4) are damaged, replace the gears (5) and (6).**
38. Refit the rear cover assembly by carrying out operations 12 to 15.
39. Smear Loctite «Form A gasket 2» (sensor sealing or equivalent) on the thread of the PTO sensor. Fit and adjust the sensor:
  - a) Screw the sensor fully in, without forcing it, so that it is in contact with the gear (6).
  - b) Unscrew the sensor 3/4 of a turn.
  - c) Tighten the nut (18) moderately and connect the harness.
 Refit the LH cylinder, reassemble the lower fastening and reconnect the supply hose.  
Refit the driving gear with the intermediate shaft and the top link support.
40. Carry out operations 9 to 13, section 7 A01 (2 speeds).  
Refit the lift cover.
41. Carry out operations 53 to 57, section 6 B01.
42. Reverse operation 7, section 6 B01.
43. Carry out operations 64 to 69, section 6 B01.
44. Carry out operations 71, 72 and 84, section 6 B01.
45. Top up the oil level of the rear axle housing.
46. Check the operation of the p.t.o. and its brake.
47. Check for leaks:
  - of the joint faces (Auxiliary spool valve support, top link support, PTO rear cover assembly, lift cover)
  - of the hydraulic fittings.



*7 C01 Engageable PTO shaft*

## CONTENTS

-	General _____	2
A.	Removing and refitting the rear bearing _____	5
B.	Disassembling and reassembling the rear bearing _____	5
C.	Disassembling and reassembling the 540 and 1,000 rpm gears and shaft front bearing _____	7
D.	External controls _____	8
E.	Plate type shaft _____	9





7C01.2

## 6100 SERIES TRACTORS

**Power take-off - Engageable PTO shaft****General**

The driven gears **(4)** and **(7)** are fitted on the p.t.o. shaft **(13)** situated in the lower rear part of the axle housing. These gears constantly engage with the driving compound gear which is driven by the upper shaft whose movement is transmitted by the p.t.o. clutch.

The p.t.o. shaft is fitted free in the roller bearing **/2\** and is force-fitted in the roller bearing **(10)** which are fitted in the axle housing and in the cover **(14)** respectively.

The hub coupler **(6)** is driven by the splined shaft **(13)**. The gears **(4)** and **(7)** drive the shaft when the coupler **(5)** is moved towards the front (540 rpm) or the rear (1000 rpm). When one of the gear **(4)** or **(7)**, equipped with bushes **(19)** and **(20)** respectively, is passive, it rotates either on the bush **/3\** or on the shaft **(13)**.

A fork **(25)** fitted on a selector rail **(22)** enables speed selection (540 or 1000 rpm).

Sealing is by means of a seal **/11\** or **/11A\** and the O-ring **(18)**. The deflector **(12)** ensures protection against foreign material.

**Lubrication of gears (4) and (7)**

The two gears are lubricated by the transmission oil. The roller bearing **/2\** has a sealed face oriented towards the 540 rpm gear. The gears are lubricated via the deflector **(1)** and the shaft **(13)** which has an axial channel and radial holes.

**List of parts**

- (1)** Deflector
- /2\** Roller bearing
- /3\** Bush
- (4)** 540 rpm gear
- (5)** Coupler
- (6)** Hub
- (7)** 1000 rpm gear
- (8)** Circlip
- (9)** Retainer ring
- (10)** Roller bearing
- /11\** Seal
- /11A\** Reinforced seal
- (12)** Deflector
- (13)** PTO shaft
- (14)** Cover
- (15)** Screw
- (16)** Sensor
- (17)** Nut
- (18)** O-ring
- (19)** Bush
- (20)** Bush
- (21)** Lever
- (22)** Selector rail
- (23)** O-ring
- (24)** Pad
- (25)** Fork
- (26)** Set screw
- (27)** Pad
- (28)** Plug



6100 SERIES TRACTORS

Power Take Off - Shiftable PTO shaft



7C01.3

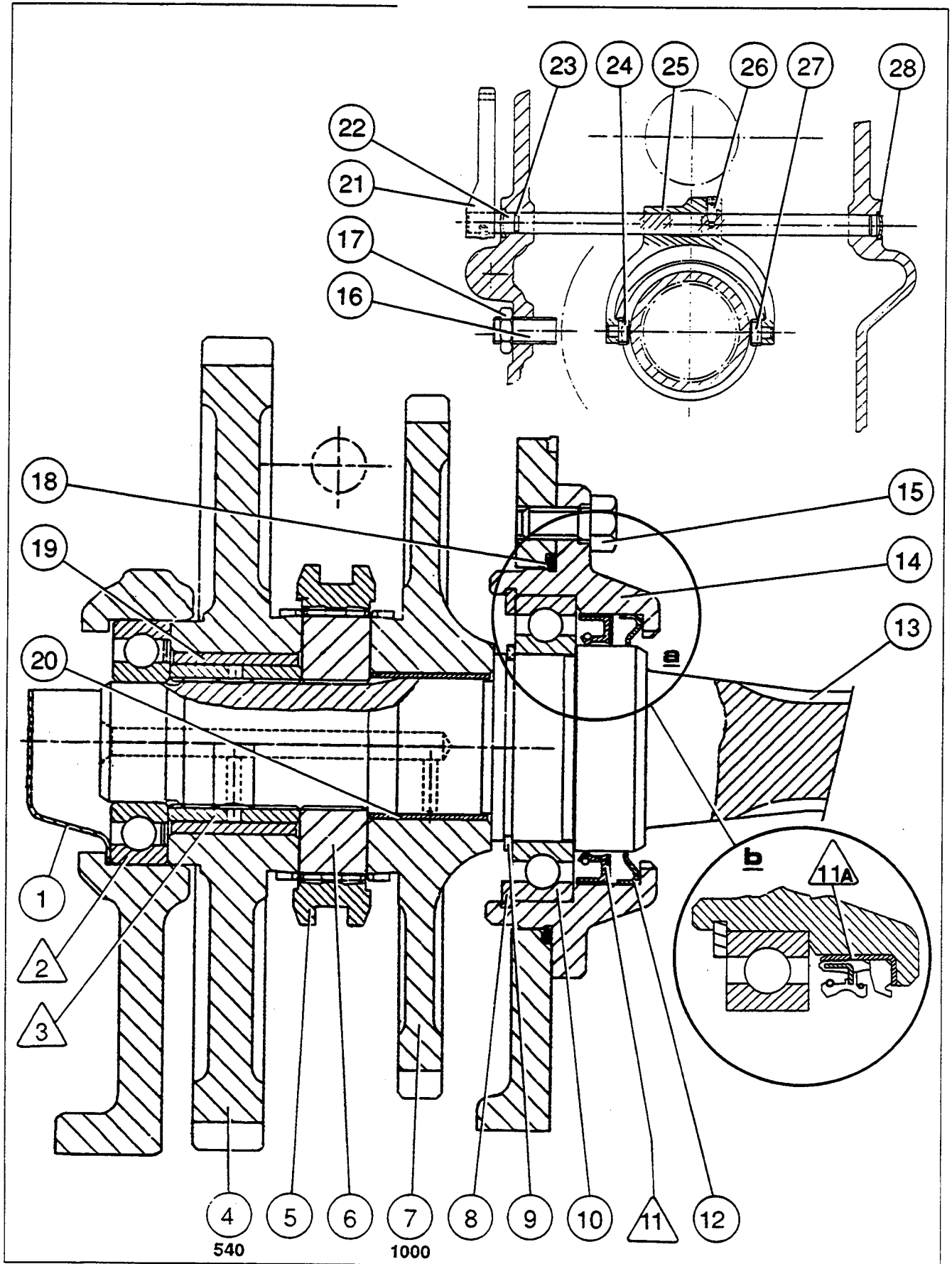



6100 SERIES TRACTORS



7C01.4

Power Take Off - Shiftable PTO shaft

Exploded

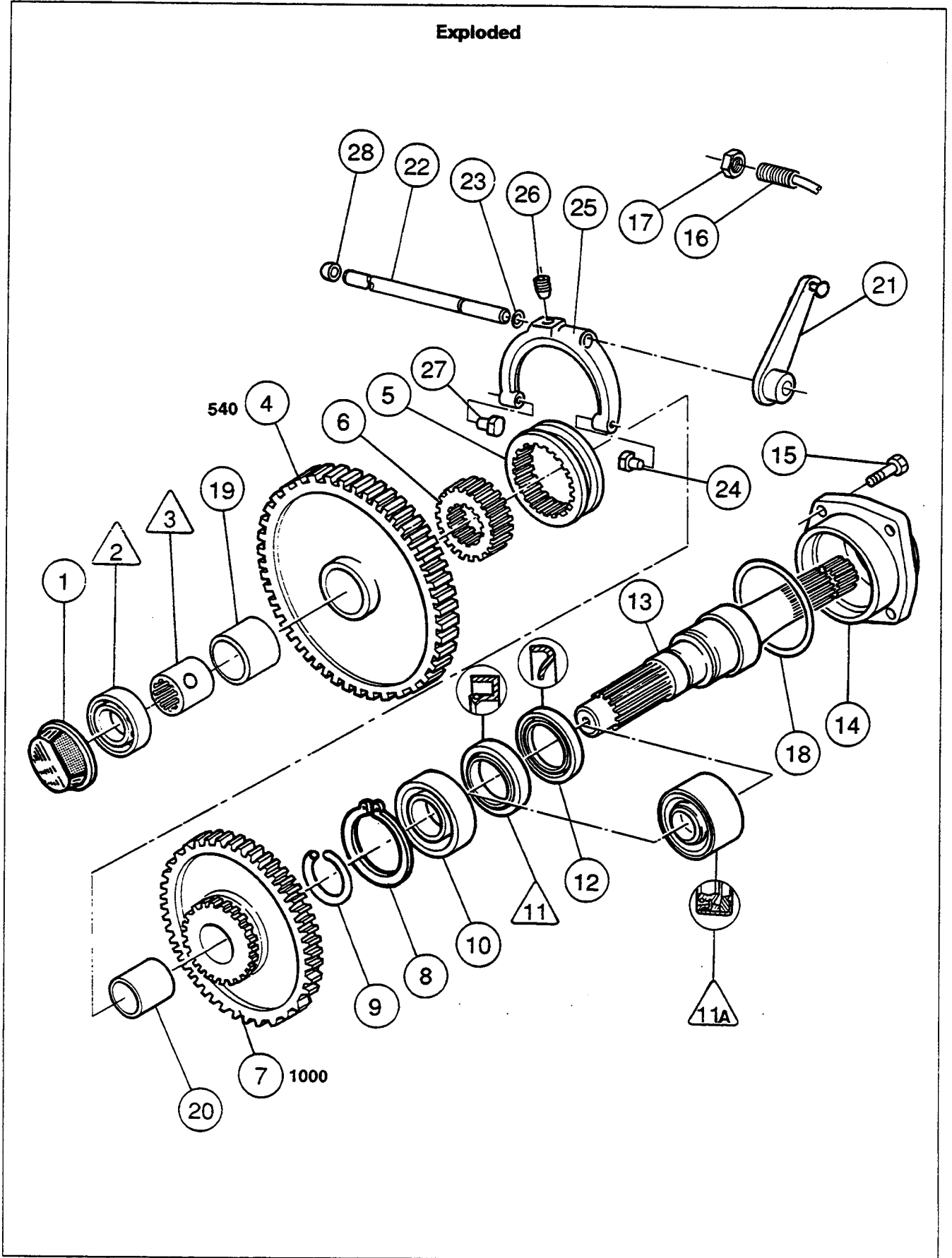



## Power Take Off - Shiftable PTO shaft

### A . Removal and refitting of rear cover

#### Disassembly

1. Partially drain the rear axle housing.
2. Place the coupler (5) on the gear (7).
3. Remove two diametrically opposed screws (15) (Fig. 1).
4. Screw two guide studs against the gear (7). The purpose of this is to hold the gear (4) and (7) (Fig. 2), the hub and the coupler in line when removing the shaft (13) and the cover assembly.
5. Remove the other two bolts (15).
6. Withdraw the shaft and cover assembly (Fig. 3). Discard the O-ring (18).

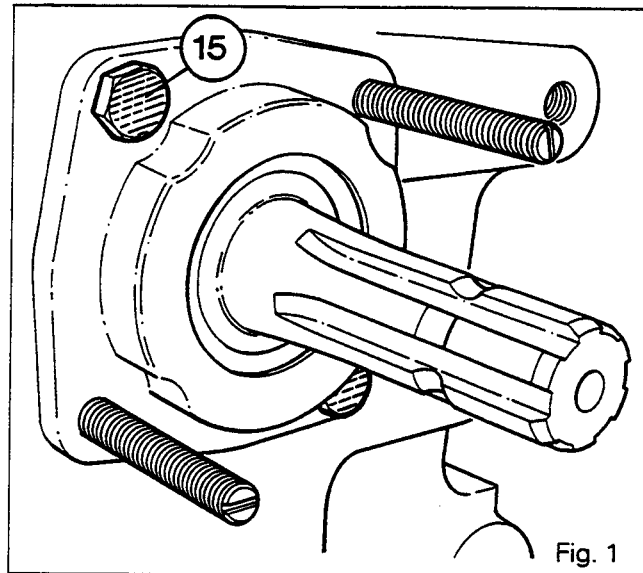

Fig. 1

#### Refitting

7. Replace the O-ring (18). Fit the shaft and cover assembly (Fig. 3).
8. Smear Loctite 542 on two screws (15) then tighten to a torque of 105 - 120 Nm.
9. Remove the two guide studs.
10. Smear Loctite 542 on the other two screws (15) then tighten to a torque of 105 - 120 Nm.
11. Top up the oil level of the rear axle housing.

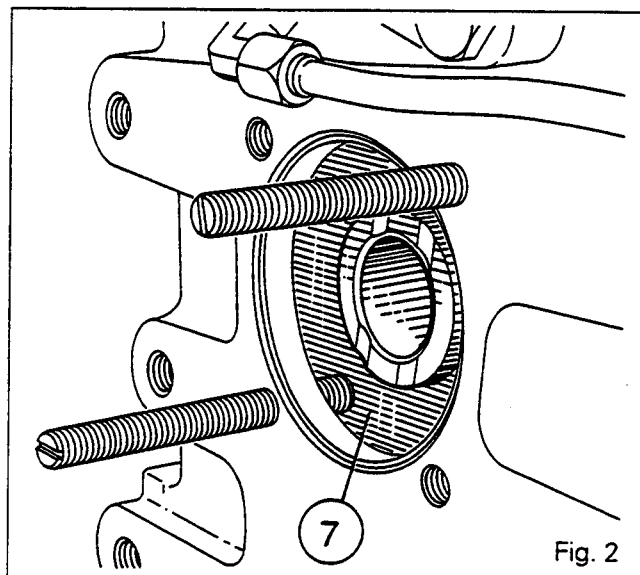

Fig. 2

### B . Disassembly and reassembly of rear cover

Remove the rear cover by carrying out operations 1 to 6.

#### Disassembly

12. Remove O-ring (18).
13. Remove circlip (8).
14. Separate the cover (14) from the roller bearing (10).
15. Remove the retainer ring (9).
16. Extract the roller bearing (10) from the shaft (13).
17. **Remove :**
  - Version a : the seal /11\ and the deflector (12).
  - Version b : the reinforced seal /11A\.

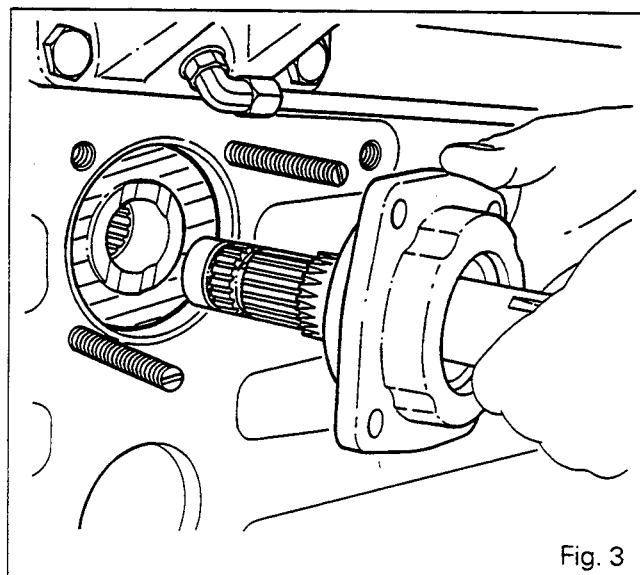

Fig. 3



# 6100 SERIES TRACTORS



7C01.6

## Power Take Off - Shiftable PTO shaft

### Reassembly

#### Version a (Fig. 4)

18. Using a press and a suitable device, fit the deflector (12) against the shoulder of the cover (14).

**Note: Assemble in the correct direction.**

19. Using a press and a suitable device, fit the seal /11\ flush with the chamfer of the cover (14) with the lip facing towards the roller bearing (10).

#### Version b (Fig. 5)

Depending on the option, a reinforced seal /11A\ is fitted in place of the seal /11\ and deflector (12).

Smear Loctite 542 on the exterior of the seal and using a suitable device, fit it against the shoulder of the cover (14) (Fig. 12). The double lip should face towards the roller cover (10).

20. Reverse operations 12 to 16 and refit the rear cover by carrying out operations 7 to 10.

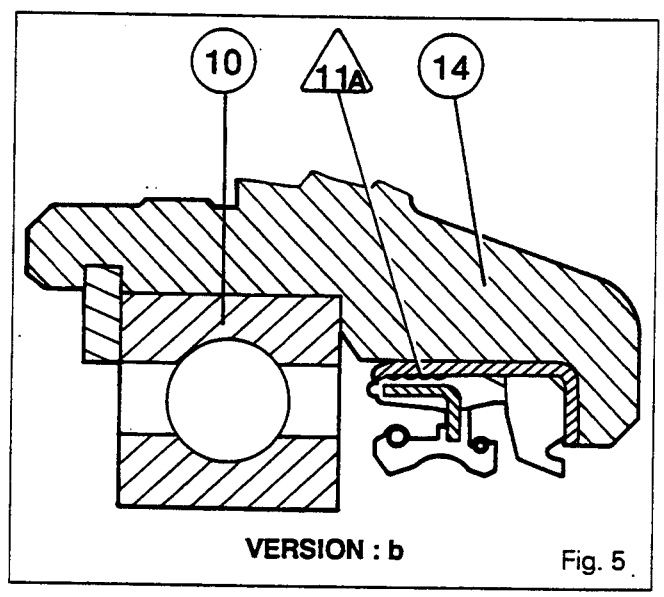
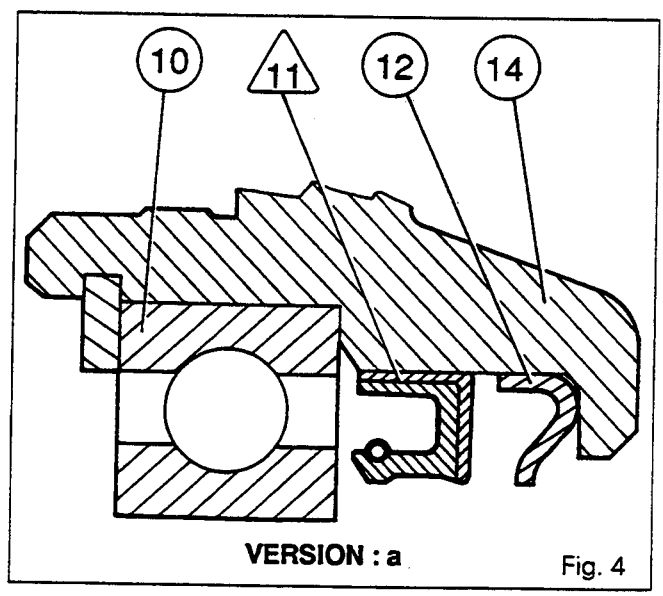



## Power take-off - Engageable PTO shaft

### C . Disassembly and reassembly of 540 and 1000 rpm gears and of the front roller bearing of the shaft

#### Disassembly

To disassemble gears (4) and (7) it is necessary to remove:

- the lift cover, see section 6 B01.
- the top link support and the driving gear, see section 7 A01.

21. In order to gain access to the sensor, remove the left-hand lift cylinder by removing the lower fastening and disconnecting the supply hose. Remove the sensor (Autotronic - Datatronic).
22. Unscrew the set screw (26).
23. Remove the selector rail (22) with the lever (21) towards the left-hand side of the tractor. Discard the O-ring (23).
- Note: The plug (28) remains in the housing.**
24. Withdraw the fork (25) with the pads (24) and (27), taking care not to drop them into the housing.
25. Remove the rear cover assembly by carrying out operations 1 to 6.
26. Remove the hub (6) with the coupler (5), the gears (4) and (7) and the bush /3\.
27. Extract the roller bearing /2\ and the deflector (1).

#### Reassembly

28. Clean and check the parts. Replace those which are defective.
29. Smear Loctite 648 on the face of the deflector (1) which meets the housing and place it in its hole. Position the aperture upwards (Fig. 6).
30. Fit the roller bearing /2\ in the housing against deflector (1) (Fig. 6).
- Note: Place the sealed part of the roller bearing towards the gear (4).**
31. Using a jet of compressed air, ensure that the channel of the shaft (13) is not obstructed. Lubricate bushes (19) and (20). Refit the gears (4) and (7), the coupler (5) with the hub (6), the bush /3\ with the toothed opening facing towards the rear of the tractor (Fig. 7).
- Note: If the bushes (19) and (20) are damaged, replace the gears (4) and (7).**
32. Engage the coupler (5) with the gear (7). Screw two guide studs against the gear (7). The purpose of this is to hold the gears in line (Fig. 2), when refitting the rear bearing assembly.

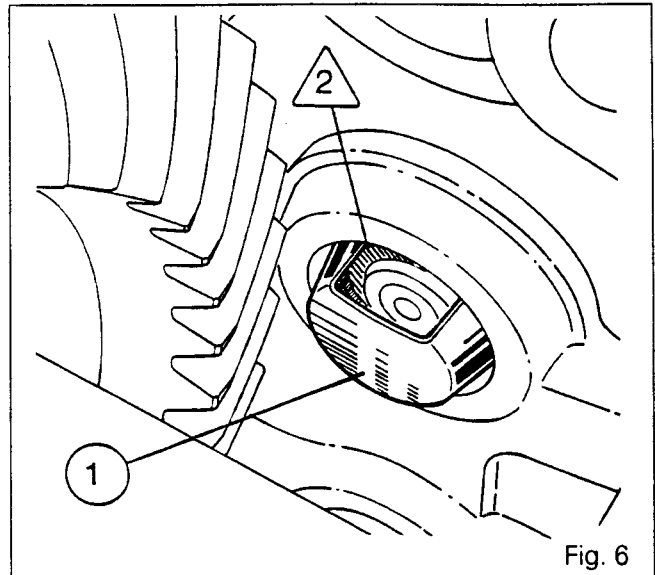

Fig. 6

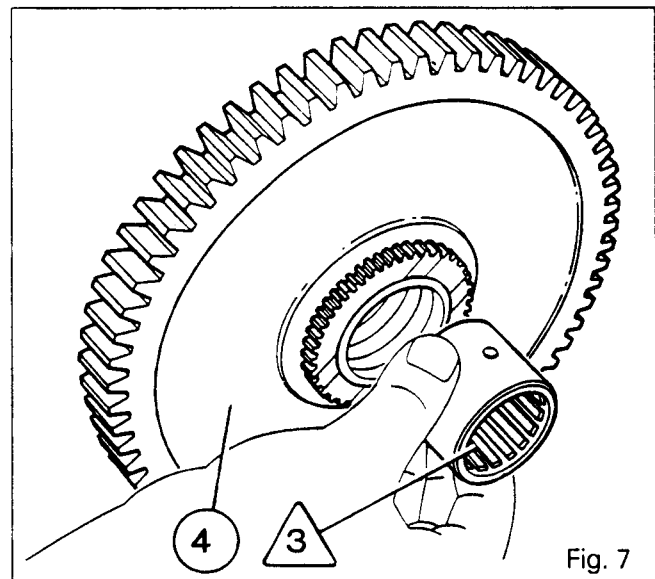

Fig. 7

33. Refit the rear cover assembly by carrying out operations 7 to 10.
34. Smear Loctite 577 (sensor sealing or equivalent) on the thread of the PTO sensor (16). Fit and adjust the sensor:
  - a) Without forcing screw the sensor in contact with the gear (7).
  - b) Unscrew the sensor 3/4 of a turn.
  - c) Tighten the nut (17) moderately and connect the harness.
35. Refit the fork (25) with the pads (24) and (27), held on the fork by two spots of miscible grease (Amber Technical or equivalent).
36. Fit a new O-ring (23). Fit the selector rail (22) with lever (21).



7C01.8

## 6100 SERIES TRACTORS

**Power take-off - Engageable PTO shaft**

37. Tighten the bolt (26) after coating it with Loctite 221. Manually check the operation of the fork. Reinstall the left-hand ram. Reinstall the lower attachment and reconnect the supply hose.
38. Reinstall the driving gear and the 3rd point support. Carry out procedures 78 to 88, Section 7 A01.
39. Reinstall the lift cover, see Section 6 B01.
40. Adjust the economy PTO control, see Section 7 A01, Part E.
41. Top up the oil in the rear axle housing.
42. Check the operation of the power take-off and its brake.
43. Check for leaks on:
  - the mating faces (distributor support, 3rd point support, PTO rear bearing and lift cover),
  - hydraulic unions.

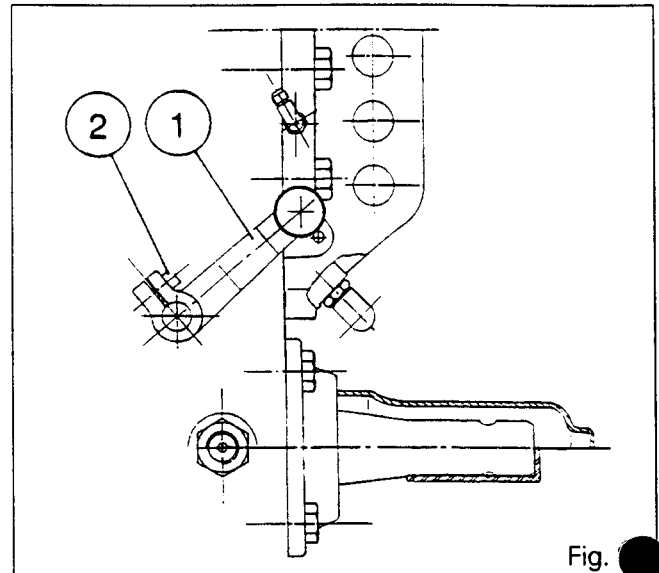

Fig.

**D . External controls (Fig. 9)**

- (1) Lever
- (2) Bolt
- (3) Locking plate

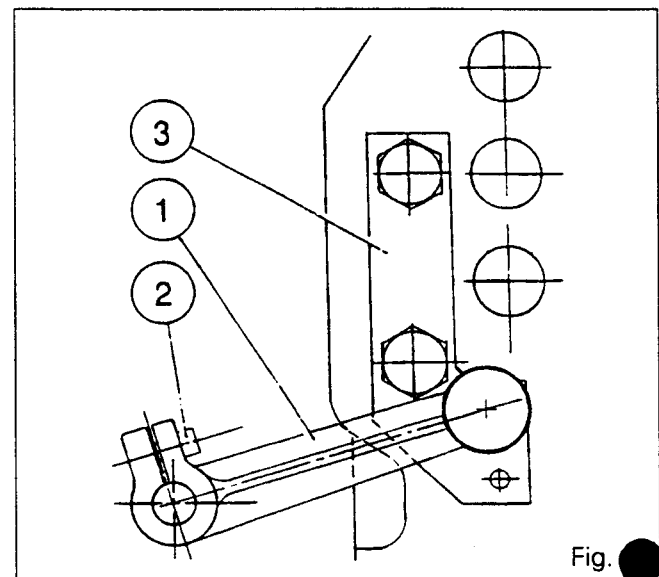

Fig.



## Power take-off - Engageable PTO shaft

7C01.9

### E . Plate type shaft (Fig. 10)

#### Special points

The plate type shaft **(13)** allows the fitting of an interchangeable end piece **(1)** (6 or 21 splines).

This end piece is mounted on the shaft **(13)** by means of two dowels **(2)** and bolts **(3)**.

When the PTO is not used, a protector **(4)** is locked (1/8th of a turn) on the spacers **(5)**.

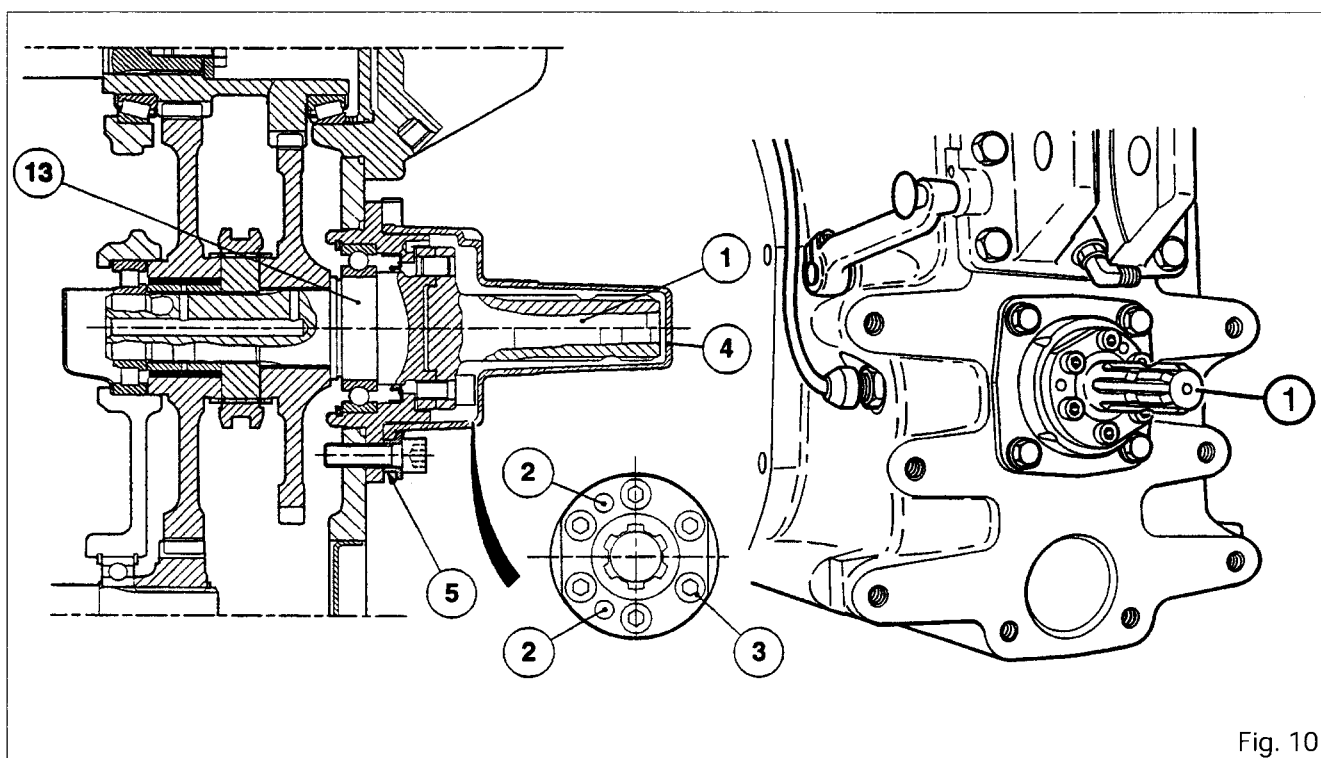

Fig. 10







**Power Take Off - GSPTO**

*7 D01 Ground speed Power take-off*

CONTENTS

- <b>General</b> _____	<b>2</b>
<b>A. Disassembly of power take-off (2WD version)</b> _____	<b>7</b>
<b>B. Reassembly of power take-off (2WD version)</b> _____	<b>9</b>
<b>C. Disassembly of power take-off (4WD version)</b> _____	<b>11</b>
<b>D. Reassembly of power take-off (4WD version)</b> _____	<b>12</b>
<b>E. Fitting and adjusting the control cable</b> _____	<b>13</b>



7D01.2

## 6100 SERIES TRACTORS

**Power Take Off - GSPTO****General**

6100 series tractors can be equipped with a ground speed power take-off .

Unlike the independent p.t.o. system or the p.t.o. system which depends on the engine speed, the ground speed p.t.o. is driven by the driving pinion, and the speed of the p.t.o. shaft is proportional to the speed of the tractor.

**Operation**

The bevel drive pinion comprises a gear **(31)** which constantly engages either with the pinion **(16)** (2WD - page 4) or with the transfer gear **(33)** (4WD - page 3). The shaft **(18)** (2WD) or the shaft **(32)** (4WD) can be made to rotate with the shaft **(8)** by means of the coupler **(10)**. The pinion **(3)** mounted at the end of the shaft **(8)** drives the 540 rpm gear of the rear power take-off shaft.

The coupler **(10)** is moved by a pad fitted on a pin mounted at the bottom left of the rear axle housing and controlled by a connecting rod and a cable activated by a lever in the cab.

**List of parts**

	2WD	4WD
<b>(1)</b> Plug	•	•
<b>(2)</b> Circlip	•	•
<b>(3)</b> Pinion	•	•
<b>(4)</b> Circlip	•	•
<b>(5)</b> Ball bearing	•	•
<b>(6)</b> Circlip	•	•
<b>(7)</b> Circlip	•	•
<b>(8)</b> Shaft	•	•
<b>(9)</b> Circlip	•	•
<b>(10)</b> Coupler	•	•
<b>(11)</b> Screw	•	•
<b>(12)</b> Cover	•	•
<b>(13)</b> Needle roller bearing	•	•
<b>(14)</b> Bearing cup	•	•
<b>(15)</b> Bearingcone	•	•
<b>(16)</b> Gear	•	•
<b>(17)</b> Circlip	•	•
<b>(18)</b> 2WD shaft	•	•
<b>(19)</b> Bearing cone	•	•
<b>(20)</b> Bearing cup	•	•
<b>[21]</b> Shim(s)	•	•
<b>(22)</b> Spacer	•	•
<b>(23)</b> Circlip	•	•
<b>(24)</b> Plug	•	•
<b>(25)</b> Double pin	•	•
<b>(26)</b> Double pin	•	•
<b>(27)</b> Sleeve	•	•
<b>(28)</b> Sleeve	•	•
<b>(29)</b> Shaft	•	•
<b>(30)</b> Circlip	•	•
<b>(31)</b> Gear	•	•
<b>(32)</b> 4WD shaft	•	•
<b>(33)</b> Transfer gear	•	•



6100 SERIES TRACTORS



7D01.3

**Power Take Off - GSPTO**

Overall view  
GSPTO - 4 WD

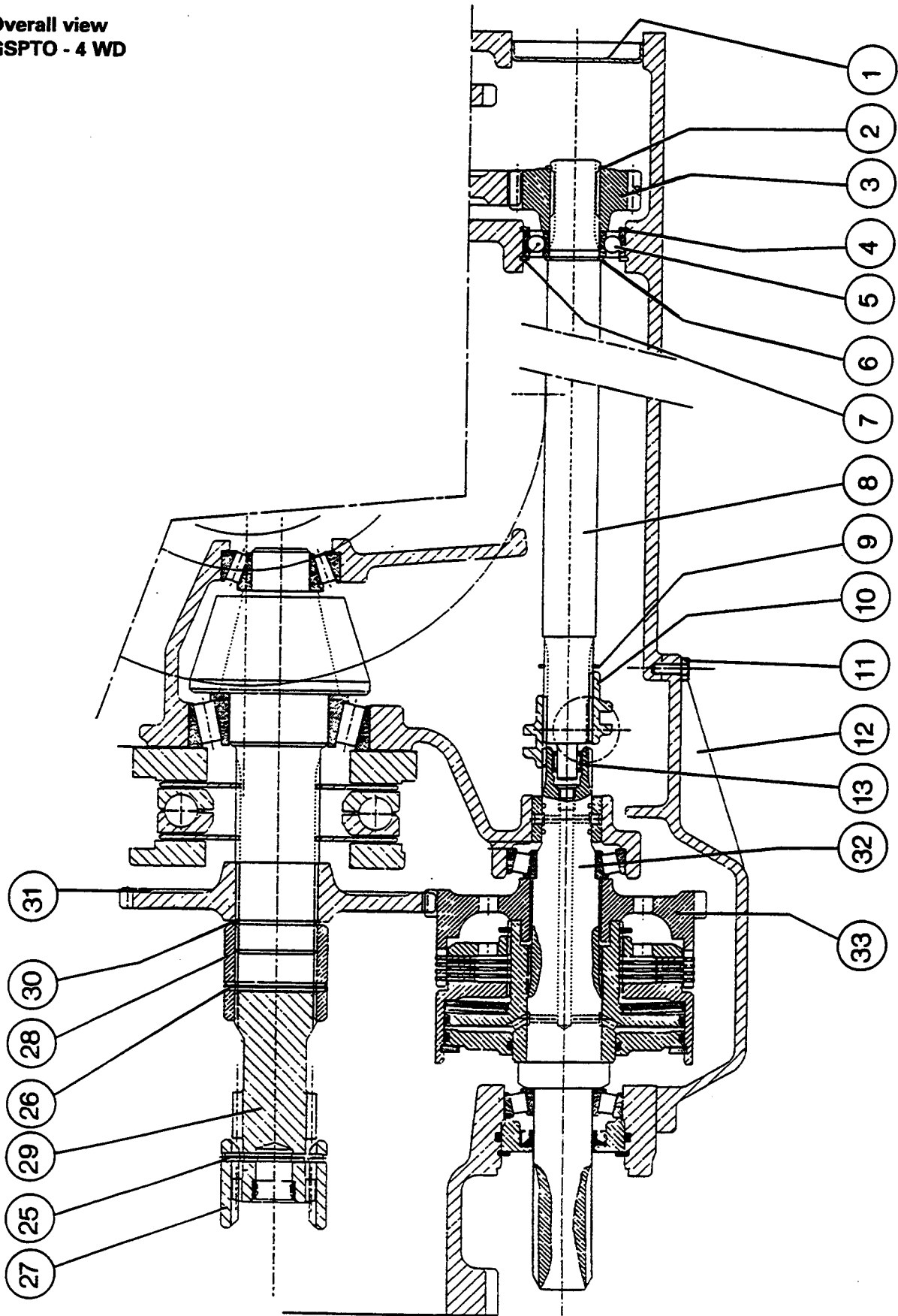



7D01.4

6100 SERIES TRACTORS



Power Take Off - GSPTO

Overall view  
GSPTO - 2 WD

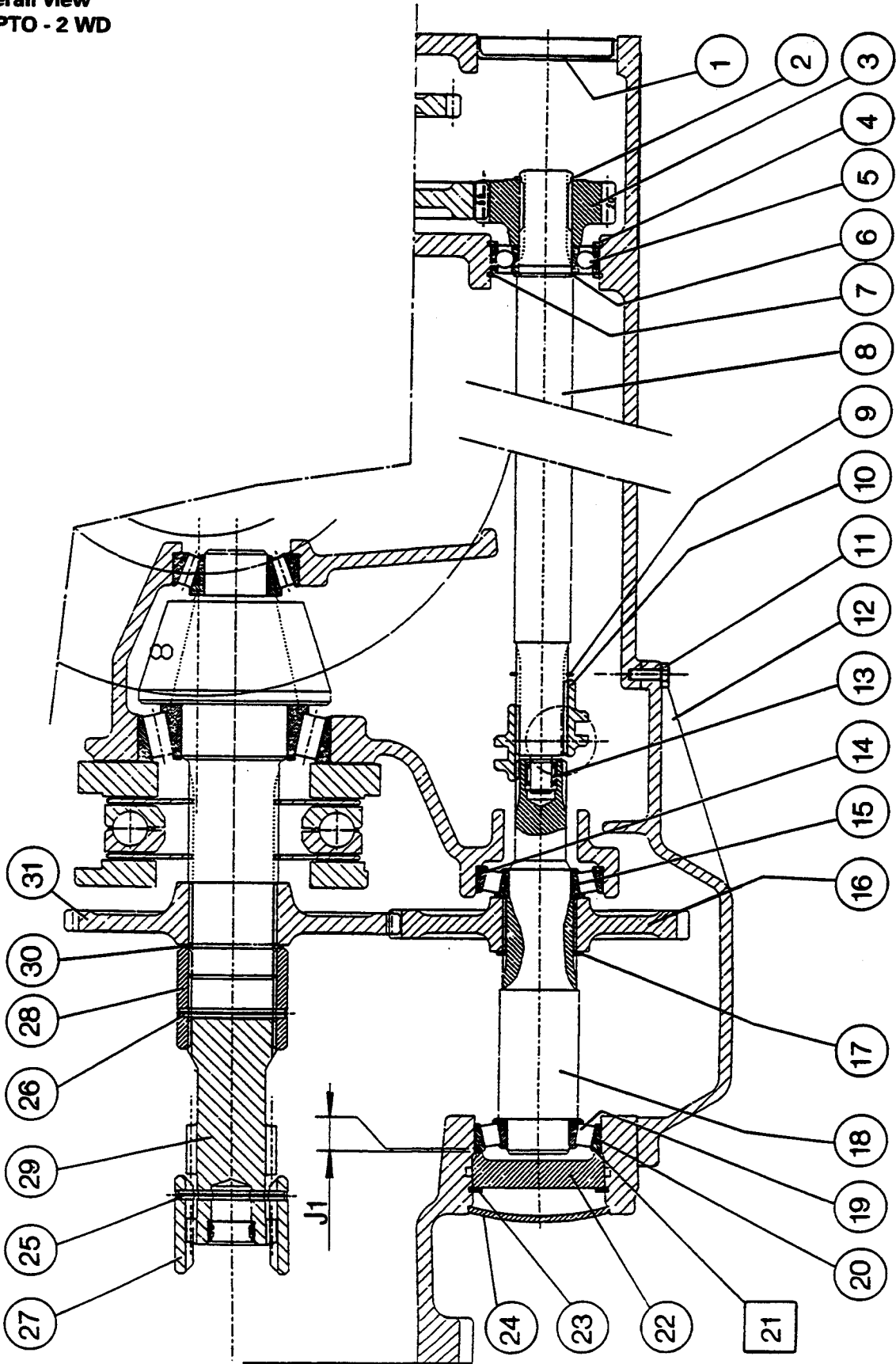



6100 SERIES TRACTORS



7D01.5

**Power Take Off - GSPTO**

Exploded view - 4 WD

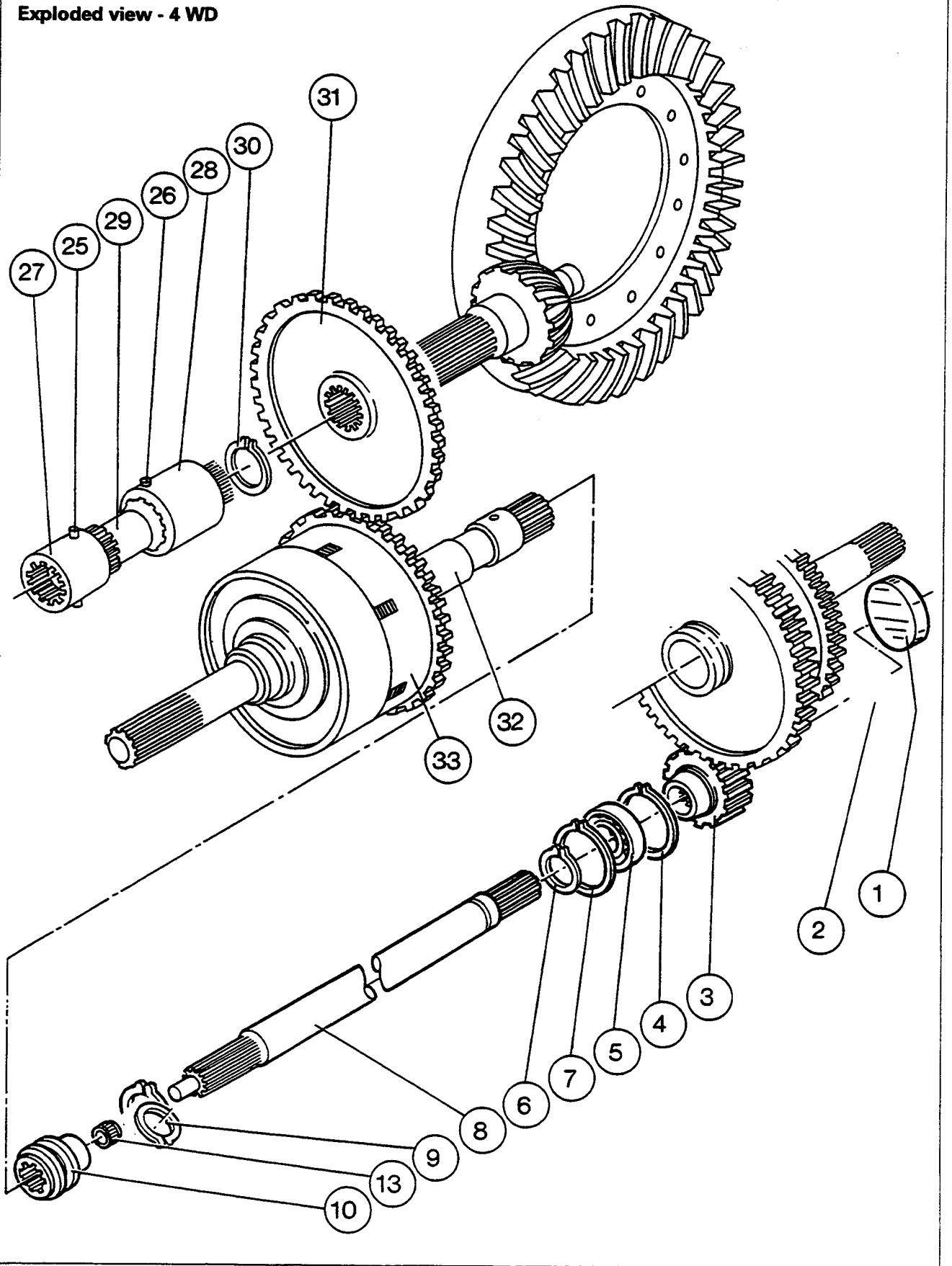



6100 SERIES TRACTORS



7D01.6

**Power Take Off - GSPTO**

Exploded view - 2 WD

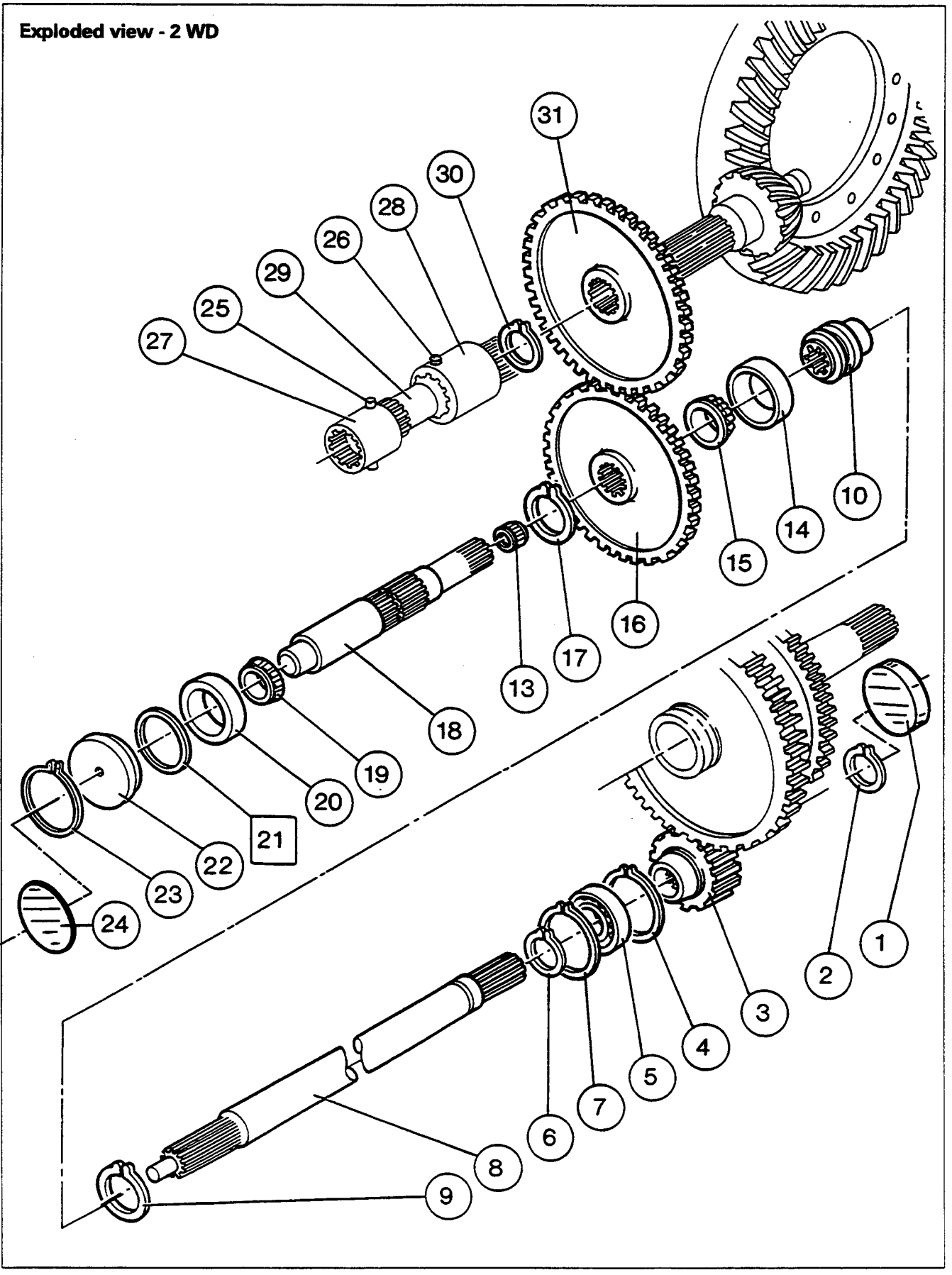



## Power Take Off - GSPTO

### A .Disassembly of power take-off (2WD version)

1. Immobilise the tractor. Drain the transmission oil. Remove the lubricating tube fitted on the lower covers of the centre housing and of the gearbox.
2. Remove the screws (11).
3. Remove the cover (12).  
**Note: Save the spring (3) (Fig. 1).**
4. Remove the retaining tube (4) for the control pivot (7) and the locking plunger (2) (Fig. 1).
5. Disconnect the control cable (1) and remove the control pivot (7) (Fig. 2).  
**Note: The finger (1) is force-fitted in the control pivot (Fig. 1).**
6. Remove the O-ring (5) (Fig. 1).
7. Remove the drawbar.
8. Extract the plug (1) (Fig. 3).
9. Remove the circlip (2).
10. Withdraw the pinion (3) (Fig. 4).

Fig. 1

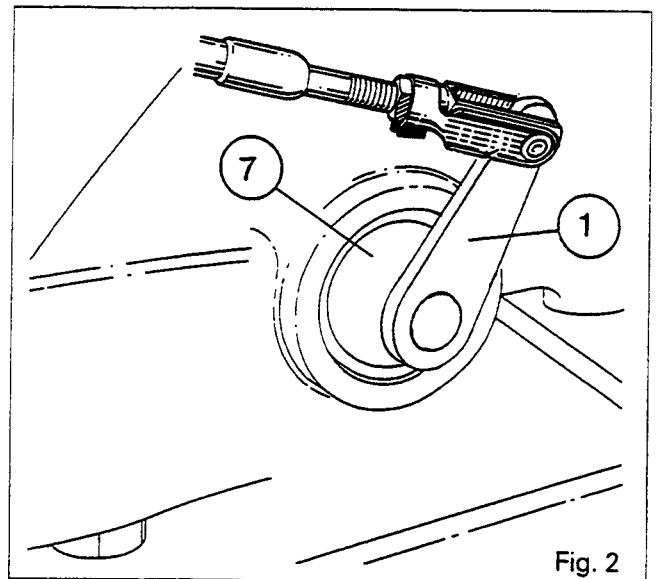
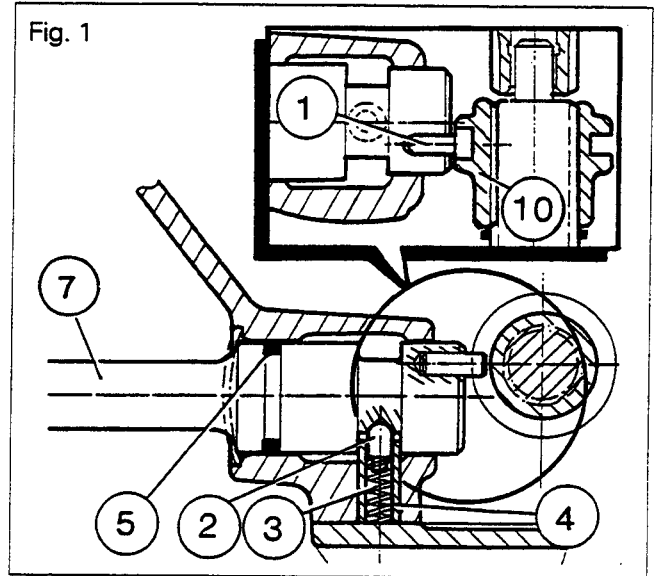

Fig. 2

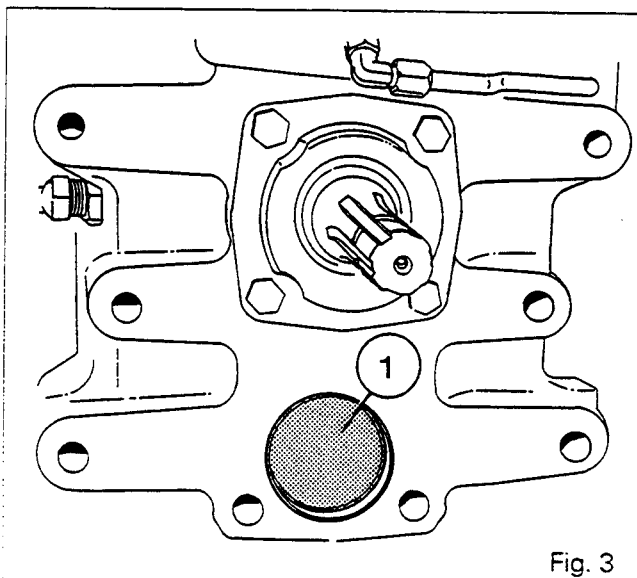

Fig. 3

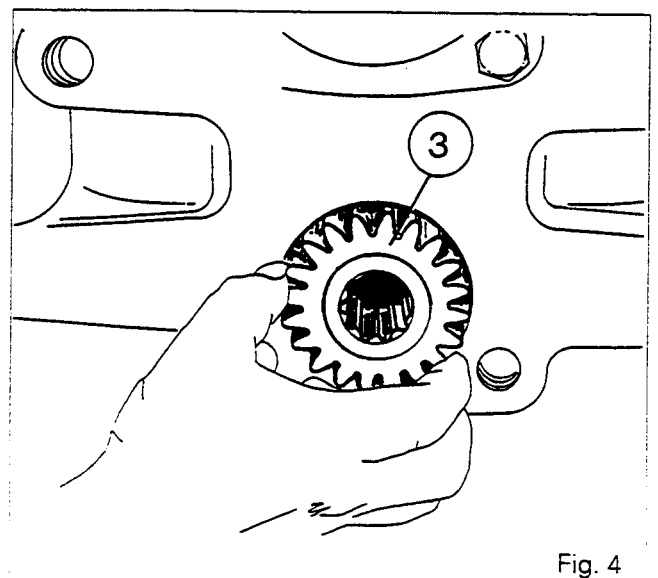

Fig. 4





7D01.8

## 6100 SERIES TRACTORS

**Power Take Off - GSPTO**

11. Remove the circlip (4) with long-nose pliers (Fig. 5).
12. Withdraw the shaft (8) with the ball bearing (5), then remove the coupler (10).  
**Note: If necessary, remove the circlip (7).**
13. Remove the circlips (6) and (9).
14. Extract the ball bearing (5) with a press.
15. Extract the plug (24).
16. Remove the circlip (23) and the spacer (22).
17. Remove the shims [21].
18. Remove the cup(20).
19. Withdraw the shaft (18) assembled with the bearing cone (19) .
20. Remove circlip (17) while holding the gear (16).
21. Remove the gear (16) and the bearing cone (15).
22. Extract the cone(19) and remove the circlip (17) from the shaft (18).  
**Note: Keep the cones and the cups paired if they are to be reused.**  
**The roller bearing (13) is pressed in to the shaft (18).**
23. Extract the cup (14) with a suitable extractor.

**If removing the gear (31) it is necessary to remove the right-hand hydraulic cover.**

24. Immobilise the tractor.
25. Apply the handbrake.
26. Lift the tractor with a jack.
27. Put a prop in position.
28. Remove the wheel.
29. Remove the right hydraulic cover.  
Carry out operations 2 to 14, section 9I01.

**Tractors without creeper gears**

30. Drive the double pins (25) and (26) from the sleeves (27) and (28).
31. Slide the sleeves towards one another on the shaft (29).
32. Detach the shaft and sleeve assembly.
33. Remove the circlip (30).
34. Detach the gear (31).

**Note: On 2WD tractors (without G.S. PTO) the gear (31) is omitted but the circlip (30) must remain in place.**

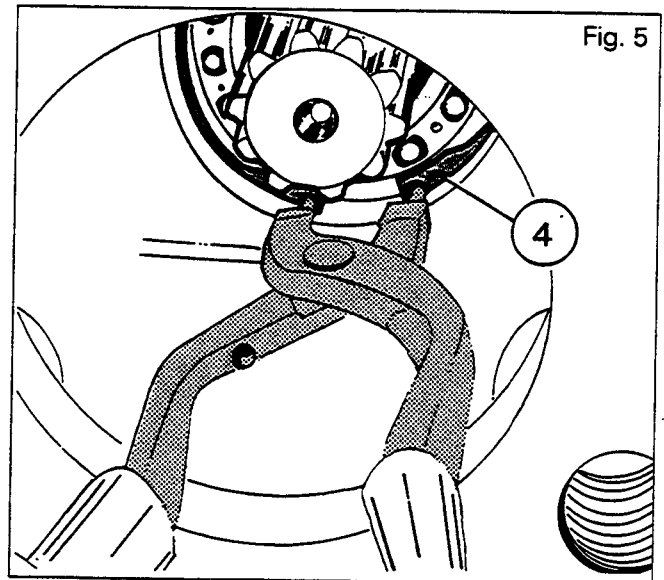
**Tractors with creeper gears**

35. Remove the fork, the sleeve assembly, the connecting shaft and the coupler.
36. Remove the circlip (30).
37. Remove the gear (31).



## Power Take Off - GSPTO

### B . Reassembly of power take-off (2WD version)

38. Clean and check the parts, replacing any which are defective.

**If carrying out work on the gears (31).**

**Tractors with creeper gears**

39. Refit the gear (31).

40. Refit the circlip (30).

41. Reattach the fork, the sleeve assembly, the connecting shaft and the coupler. Position the slot of the sleeve (28) fitted on the driving gear as shown Fig. 6. Replace the pins. Adjust the fork (see 5 D01.A)

**Tractors without creeper gears**

42. Refit the gear (31).

43. Refit the circlip (30).

44. Refit the assembly (connecting shaft and sleeves), then position the sleeves (27) and (28) on the shaft (29) (Fig. 6).

45. Mount the double pins (26) and (25) on the sleeves.

**Note: Position the grooved end of the sleeve (28) towards the rear of the tractor (Fig. 6). Replace the pins. The long pin is fitted into the sleeve (27).**

**Tractors with or without creeper gears**

46. If removed, refit the right hydraulic cover.  
Carry out operations 15 to 27, section 9I01.

47. Push the cup (14) as far as it will go against the shoulder of the housing.

48. Push the bearing cone (19) on the shaft (18) as far as it will go against the shoulder using a press and a suitable device, then position the circlip (17).

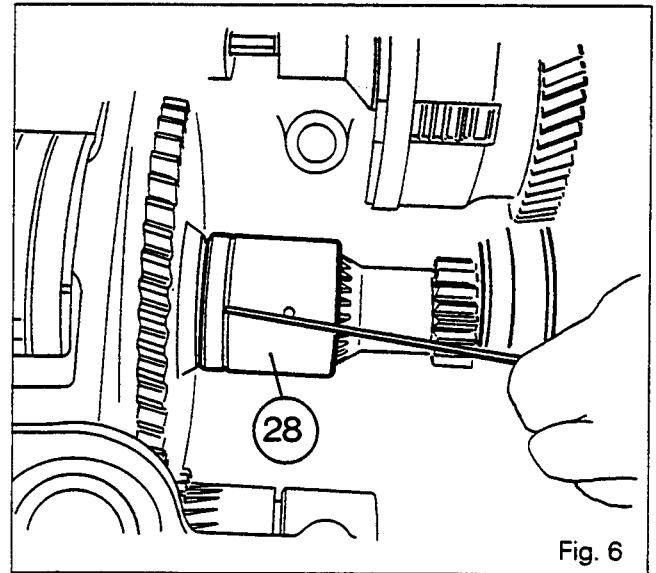

Fig. 6

49. Check that the needle roller bearing (13) is present.

50. In order to be able to turn the shaft to carry out spacing  $J_1$ , do not mount the gear (16).

Position the cone (15). Fit the shaft (18) assembled with the cone (19) and the circlip (17).

51. Refit the cup (20), the spacer (22) and the circlip (23).

**Note: To obtain correct shimming, ensure that the spacer moves freely in the bore of the housing.**

52. Carry out shimming on the shaft (18) so as to obtain:  $J_1 = 0$  to  $0.10$

53. Place the tip of the dial gauge against the spacer (22) (Fig. 7).

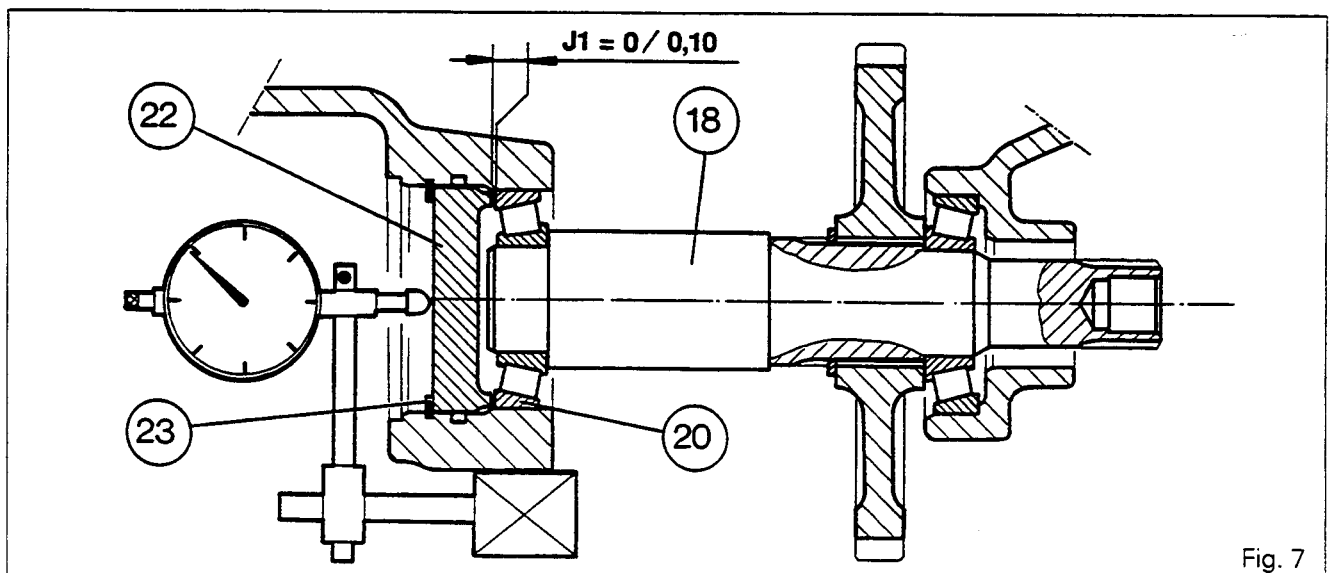

Fig. 7



7D01.10

## 6100 SERIES TRACTORS

**Power Take Off - GSPTO**

54. Through the aperture in the cover (12), pull on the shaft, turning it back and forth, in order to seat the bearing cones correctly in the cups.
55. Set the dial gauge to zero.
56. Repeat the operation while pushing the shaft.
57. Select the necessary thickness of shims to provide J1.
58. Remove the circlip (23) and the spacer (22). Withdraw the shaft (18) assembled with the bearing cone (19) and the circlip (17) while holding the bearing cone (15). Refit the gear (16) the shaft (18) and the cup (20).
59. Apply two spots of grease to the shims [21] selected in operation 57 and place them against the cup (20).
60. Fit the spacer (22) and the circlip (23).
61. Clean the plug (24) and its recess in the housing.
62. Smear the edge of the plug with Loctite 542, then push it in.
63. Place the coupler (10) on the shaft (18).  
**Note: Position the small shoulder E towards the shaft (18) (Fig. 8).**
64. Fit the circlips (6) and (9) on the shaft (8).
65. Using suitable equipment, press the ball bearing (5) on to the shaft (8), until it contacts the circlip (6).
66. Check that the circlip (7) is present.
67. Mount the assembled shaft (8) in the housing (Fig. 9).
68. Mount the circlip (4).
69. Fit the pinion (3).
70. Mount the circlip (2) (Fig. 10).
71. Check the movement of the coupler (10) through the aperture in the cover (12).
72. Clean the plug (1) and the bore in the housing.
73. Smear the plug with Loctite 542, then push it in so that it is slightly recessed from the face of the housing.
74. Mount the control pivot (7) (equipped with a new O-ring (5)), placing the pad (1) in the groove of the coupler (10) (Fig. 1).
75. Clean and degrease the joint faces (cover and housing).
76. Smear the joint face of the cover with a sealing compound (Master Joint 510 or equivalent).
77. Screw two guide studs in opposite positions into the housing.
78. Mount the retaining tube (4) for the control pivot, the locking plunger (2) and the spring (3) (Fig. 1).
79. Refit the cover (12) and the lubricating tube of the engine clutch.

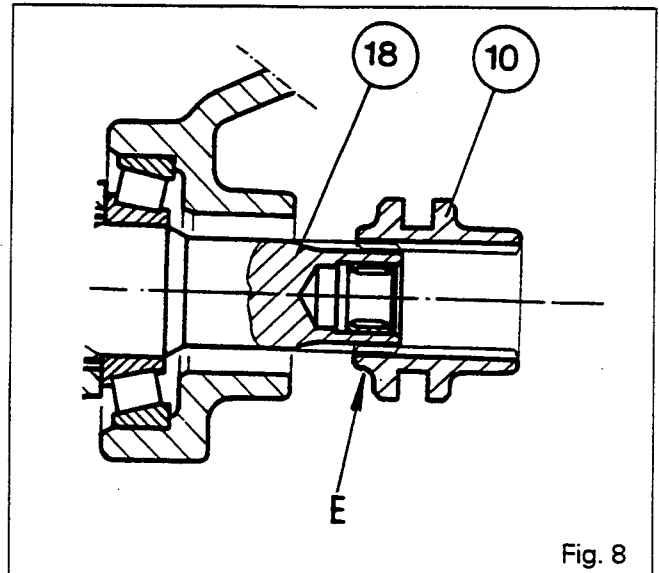

Fig. 8

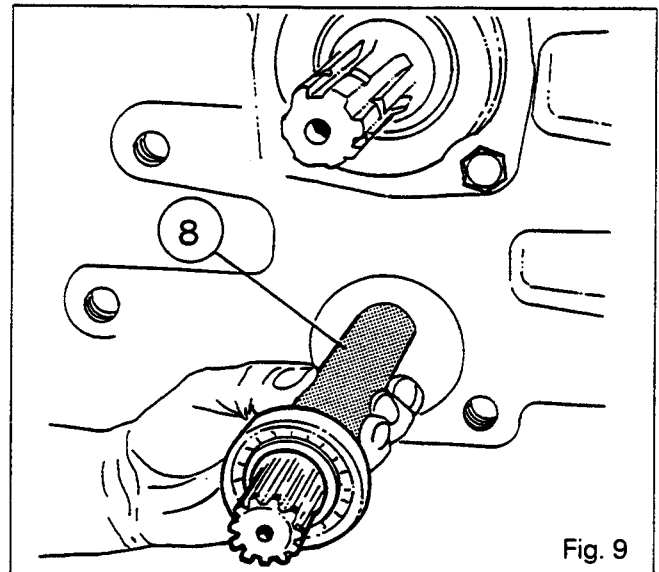

Fig. 9

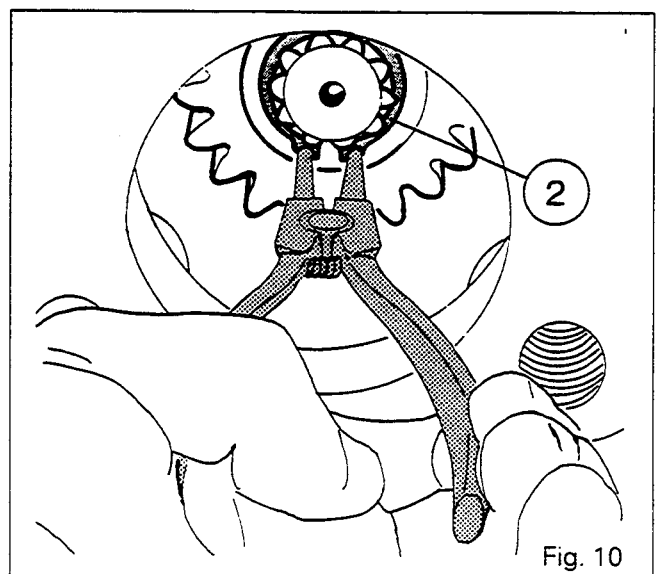

Fig. 10



## Power Take Off - GSPTO

80. Remove the guide studs. Fit and tighten the screws to a torque of 130 - 170 Nm.
81. Reconnect the G.S. PTO control cable (1) (Fig. 2).
82. Adjust the control (see § E).

**If the right hand hydraulic cover has been removed, carry out operations 83 to 85.**

83. Lift the tractor with a trolley jack.
84. Refit the wheel. Remove the prop and the jack.
85. Tighten the wheel nuts to a torque of 400-450 Nm.
86. Replenish transmission oil.
87. Refit the drawbar. (For tractors equipped with an automatic hook, check its operation). If adjustment should prove to be necessary, carry out operations 1 and 6 to 19, section 6G01.).
88. Check the operation of the GSPTO.
89. **Check for leaks :**
  - . at the joint faces
  - . at the cover under the rear axle housing.
  - . at the right hydraulic cover (if removed)
  - . at the hydraulic connectors

### Tractors without creeper gears

93. Drive the double pins (25) and (26) from the sleeves (27) and (28).
94. Slide the sleeves towards one another on the shaft (29).
95. Remove the assembly (shaft and sleeves).
96. Remove the circlip (30) and the gear (31).

### Tractors with creeper gears

97. Remove the fork, the sleeve assembly, the connecting shaft and the coupler.
98. Remove the circlip (30) and the gear (31).

## C . Disassembly of power take-off (4WD version)

90. Remove the 4 WD guard and the lubricating tube of the engine clutch. Remove shaft (8).

**Should it prove necessary to carry out work on the 4WD clutch assembly, on the bearing cones and cups, on the shaft and the needle roller bearing, refer to section 8A01.**

**If removing the gear (31) it is necessary to remove the right hand hydraulic cover.**

91. Lift the tractor with a jack. Put a prop in position. Remove the wheel. Remove the right hydraulic cover.
92. Remove the RH hydraulic cover. Carry out operations 2 to 14, section 9I01.



7D01.12

## 6100 SERIES TRACTORS

**Power Take Off - GSPTO****D .Reassembly of power take-off  
(4WD version)**

99. Clean and check the parts, replacing any which are defective.

**If carrying out work on the gear (31).****Tractors with creeper gears**

100. Refit the gear (31) and refit the circlip (30).

101. Refit the fork, the sleeve assembly, the connecting shaft and the coupler. Carry out operations 22 to 31 in section 5D01.A.

**Tractors without creeper gears**

102. Refit the gear (31) and refit the circlip (30).

103. Refit the assembly (connecting shaft and sleeves), then position the sleeves (27) and (28) on the shaft (29).

104. Fit two new double pins (25) and (26) on the sleeves.

**Note : Position the grooved end of the sleeve (28) towards the rear of the tractor (Fig. 11).**

**The long double pin is fitted in to the sleeve (27).**

**Tractors with or without creeper gears**

105. If necessary, refit the right hand hydraulic cover. Carry out operations 15 to 27, section 9I01.

**If the 4WD clutch assembly, the bearing cones and cups, the shaft and the needle roller bearing have been disassembled, refer to section 8A01 for reassembly.**

**If necessary, carry out operations 9 to 12, section 5D01.A in reverse.**

106. Place the coupler (10) on the shaft (32).

**Note : Position the small shoulder E towards the shaft (32) (Fig. 12).**

107. Carry out operations 64 to 82.

**If the right hand hydraulic cover has been removed, carry out operations 83 to 85.**

108. Carry out operations 86 to 88.

**109. Check for leaks:**

- . at the joint face of the cover under the rear axle housing
- . at the right hydraulic cover (if removed)
- . at the hydraulic connectors.

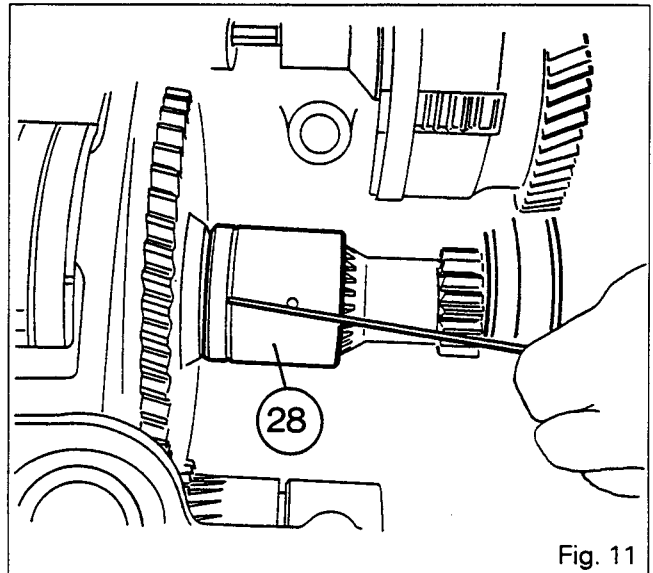

Fig. 11

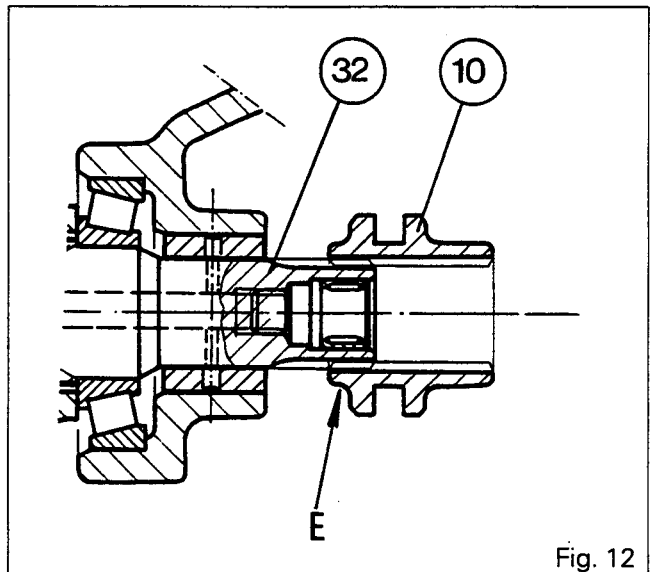

Fig. 12



## Power Take Off - GSPTO

7D01.13

### E. Fitting and adjusting the control cable

110. Put the control lever **L** (Fig. 13) into the GSPTO position (engaged) Fig. 14.
111. Screw the clevis **(1)** on to the end of the cable thread **(6)**.
112. Fit the clevis **(1)** to the lever **L** with the clip **(7)**. Tighten the nut **(2)**.
113. Adjust the cable stop **(5)** with the nut **(3)** at the end of the thread.
114. Tighten the nut **(4)** checking that the cable is not blocked.
115. Put rod **(8)** into the «engaged» position (Fig. 15), ensuring that it is correctly locked.
116. Screw on the clevis **(1)** to the end of the cable thread **(6)** Fig. 15.
117. Attach the clevis **(1)** to rod **(8)** with the clip **(7)**. Tighten the nut **(2)**.
118. Adjust the cable stop **(5)** using the nut **(4)**, ensuring that rod **(8)** remains in the «engaged» position.
119. Tighten the nut **(3)**. Test that the control lever operates correctly in the disengaged position and check that the cable is not restricted in the position «engaged».
120. Check the dashboard indicator operates correctly.

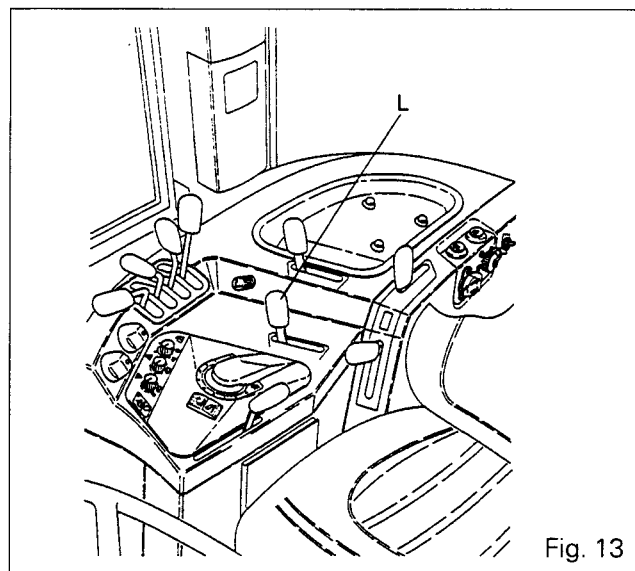

Fig. 13

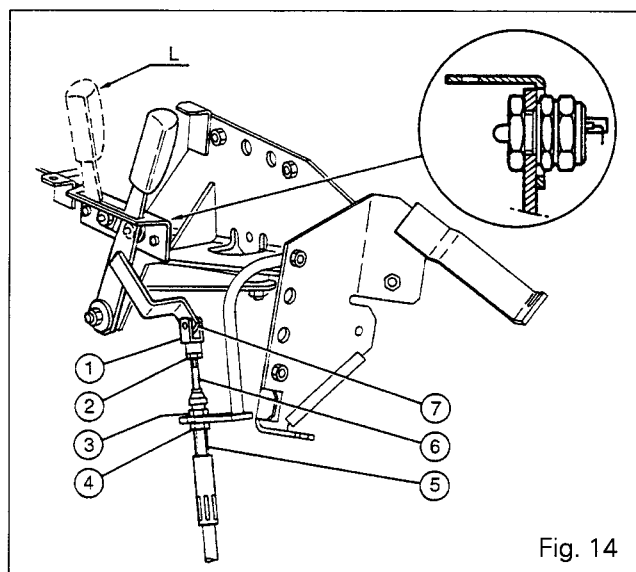

Fig. 14

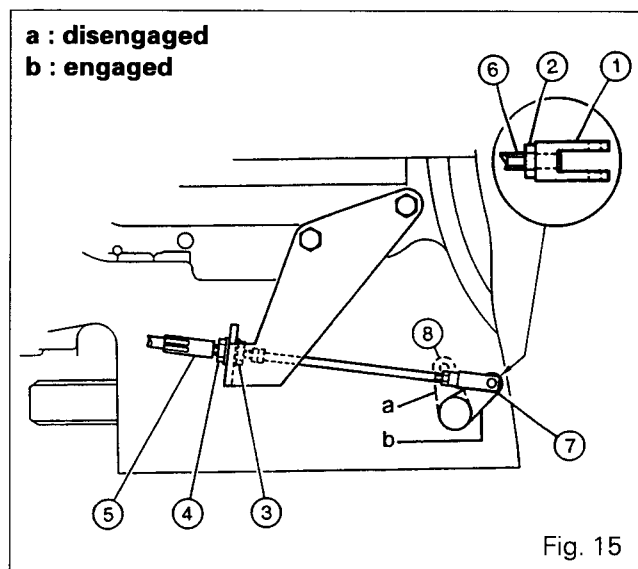

Fig. 15





---

6100 SERIES TRACTORS

---



7E01.1

## **Rear axle - PTO clutch**

### 7 E01 Power take-off clutch

#### CONTENTS

- <b>General</b> _____	<b>2</b>
- <b>Operation</b> _____	<b>2</b>
<b>A. Removal and refitting of PTO clutch</b> _____ (2-speed version)	<b>5</b>
<b>B. Removal and refitting of PTO clutch</b> _____ (4-speed version)	<b>5</b>
<b>C. Disassembly and reassembly of clutch</b> _____	<b>6</b>
<b>D. Service tool</b> _____	<b>8</b>





7E01.2

## 6100 SERIES TRACTORS



## Rear axle - PTO clutch

## General

The power-take-off clutch, fitted at the front of the rear axle housing, is driven by a shaft connected via splines to the main clutch input shaft which is driven by the flywheel. The PTO clutch drive shaft passes through the primary shaft of the gearbox, the Speedshift or Dynashift, the reverse shuttle and the layshaft.

The clutch assembly is composed of the following principal components :

- A housing (9) supported by two ball bearings (2) and (7) separated by a sleeve (4) centred in a hole in the centre housing. The sleeve (27) supports the ball bearing (22), the drive hub (21) and piston (10).
- A clutch housing (15) comprising a pack of discs (17) and inter-mediate plates (14) is fitted on the support housing.

The housing (9) has exterior helical teeth which drive the gear of the hydraulic pump. The roller bearings and the plates are lubricated.

The clutch has 3, 4 or 5 plates, depending on the version.

## Version without PTO

On tractors without PTO, an assembly comprising a driving gear (1) and sleeve (2) (Fig. B) replaces the PTO clutch. The sleeve is smeared with Loctite 648 and is inserted in the gear by a press.

On the right cover, the solenoid valves of the PTO and of the PTO brake are replaced with plugs.

The PTO brake feeder tube is absent.

The PTO speed sensor is replaced with a plug.

The top link support has 2 plugs mounted on the lubrication and brake ducts of the PTO

A cover plate (fitted using Loctite 510 or equivalent) replaces the rear cover assembly.

The lubrication tube of the gear driving the PTO is absent.

A right-angled connector replaces the T-connector.

## Operation

## PTO engagement

The clutch is fed by the 17 bar hydraulic circuit through the PTO solenoid valve situated on the right side cover. The oil enters the support housing (9) through channels a and c, and chamber b. It pushes the piston (10) which presses the outer plates (14) against the inner plates (17). The outer plates (14) have lugs which are driven by the clutch housing (15) and the inner plates (17) drive the hub (21), which is splined to the intermediate shaft which is in turn splined to the PTO compound gear. At the same time the pressure which was acting on the PTO brake piston is cut off, enabling the 540 and 1000 rpm gears to turn freely. When the clutch is engaged, the plates are cooled and lubricated.

## PTO braking

When the supply is cut off, the spring (18) pushes the piston against the housing (9).

When the button is in the PTO brake position in the cab, the solenoid valve for the PTO brake directs the oil to the PTO brake situated in the top link support. The pressure acts on a piston which supports the cup on the rear taper roller bearing, progressively stopping the driving gear.

## Note:

**The clutch control shaft has been modified as from serial No. F037019 (Fig. A).**

**Fit the longer end "E" or the paint mark "P" pointing towards the input unit.**

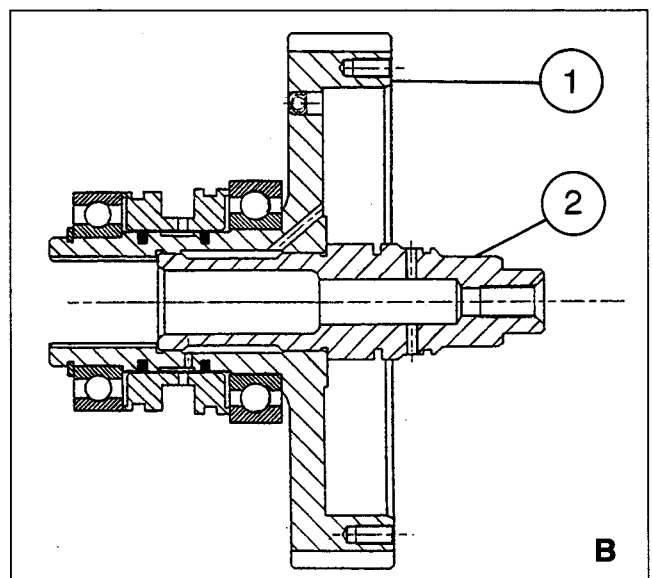
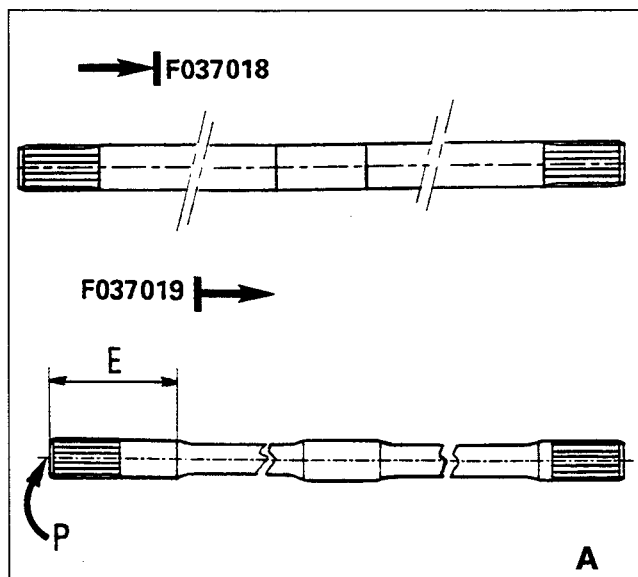



6100 SERIES TRACTORS



Rear axle - PTO clutch

7E01.3

General arrangement

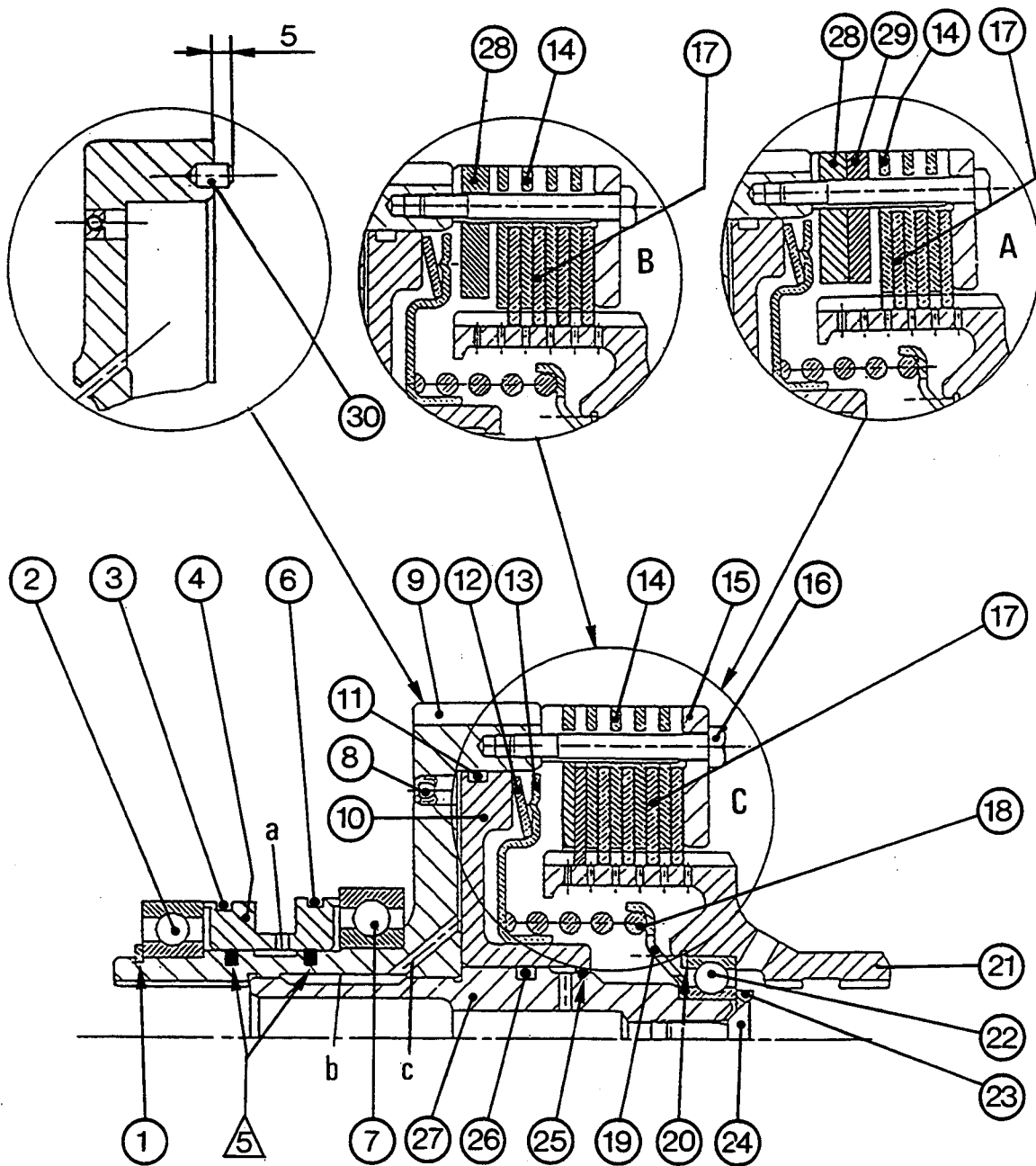

- |                        |                     |                                  |
|------------------------|---------------------|----------------------------------|
| (1) Circlip            | (13) Retainer       | (19) Spring seat                 |
| (2) Ball bearing       | (14) Outer plate    | (20) Securing ring               |
| (3) O-ring             | A : 3-plate clutch  | (21) Hub                         |
| (4) Sleeve             | B : 4-plate clutch  | (22) Ball bearing                |
| /5\ Seal rings         | C : 5-plate clutch  | (23) Washer                      |
| (6) O-ring             | (15) Clutch housing | (24) Screw                       |
| (7) Ball bearing       | (16) Bolt           | (25) O-ring                      |
| (8) Valve              | (17) Inner plate    | (26) O-ring                      |
| (9) Support housing    | A : 3-plate clutch  | (27) Sleeve                      |
| (10) Piston            | B : 4-plate clutch  | (28) Spacer, 3- and 4-plate type |
| (11) O-ring            | C : 5-plate clutch  | (29) Spacer, 3-plate type        |
| (12) Belleville washer | (18) Spring         | (30) Pins                        |



7E01.4

6100 SERIES TRACTORS



Rear axle - PTO clutch

Exploded view

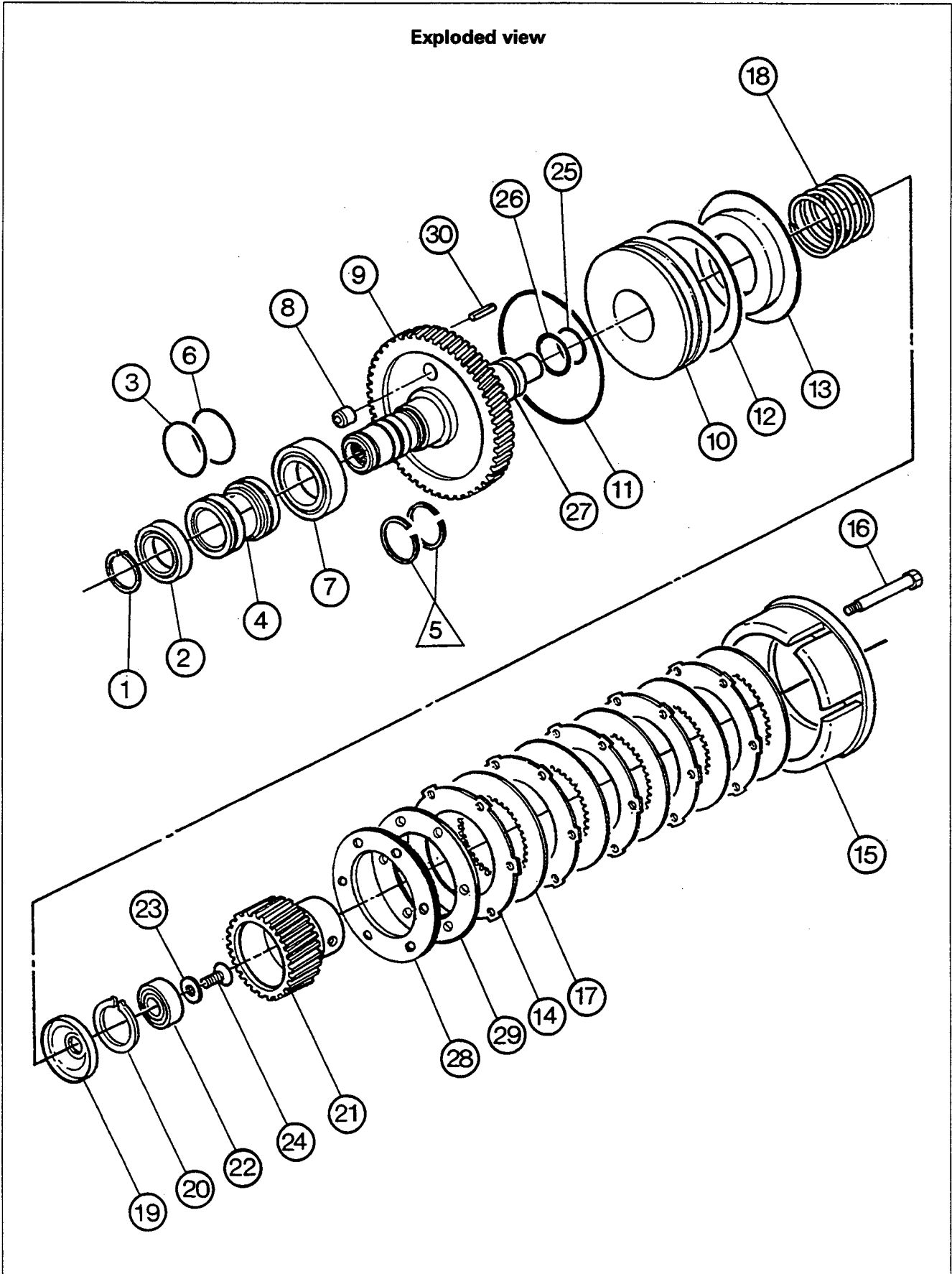



## A . Removal and refitting of PTO clutch (2-speed version)

### Removal

1. Remove the left side cover. Carry out operations 1 to 6, section 9 I02.
2. Remove the top link support, the compound gear and the intermediate shaft. Carry out operations 1 to 7, section 7 A01.
3. Remove the retaining screw **(3)** of the clutch **(1)**. Remove the clutch and the spring **(5)** (Fig. 1).

### Refitting

4. Clean and check the parts. Replace those which are defective.
5. Check that the O-rings **(2)** and **(4)** (Fig. 1) have not deteriorated.
6. Place the spring **(5)** (Fig. 1) in the hollow clutch shaft and refit the clutch, pushing it as far as possible with a lever (Fig. 2) so as to compress the spring in order to fit the screw **(3)** (Fig. 1).
7. Clean the screw and smear it with Loctite 221 and tighten it with a ring spanner (Fig. 1).
8. Refit the intermediate shaft, the compound gear and the top link support. Carry out operations 9 to 18, section 7 A01.
9. Replace the left cover. Carry out operations 7 to 19, section 9 I02.
10. Check the operation of the PTO clutch, the PTO brake and of the lift.
11. Check for leaks:
  - at the joint faces (spool valve support, top link support, left side cover)
  - at the hydraulic connectors.

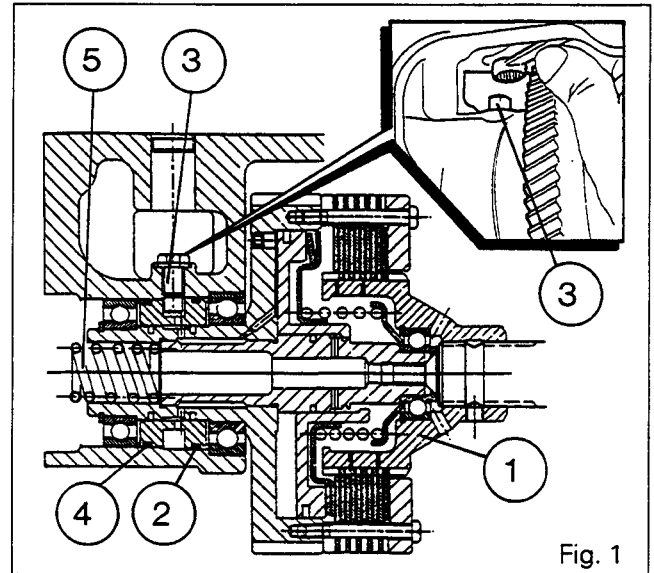

Fig. 1

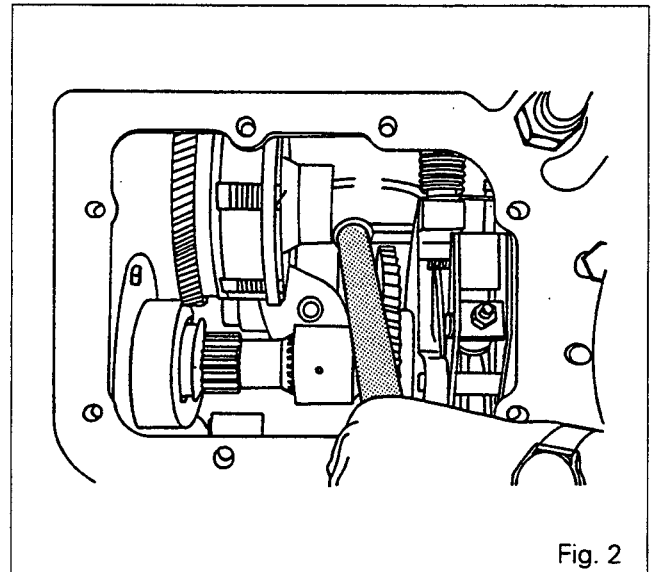

Fig. 2

## B. Removal and refitting of PTO clutch (4-speed version)

### Removal

12. Remove the left side cover. Carry out operations 1 to 6, section 9 I02
13. Remove the top link support, the compound gear and the intermediate shaft. Carry out operations 60 to 68 and 72 to 78, section 7 A01.
14. Remove the retaining screw **(3)** of the clutch **(1)**. Remove the clutch and the spring **(5)** (Fig. 1).

### Refitting

15. Clean and check the parts. Replace those which are defective.
16. Check that the O-rings **(2)** and **(4)** (Fig. 1) have not deteriorated.
17. Place the spring **(5)** (Fig. 1) in hollow clutch shaft and refit the clutch, pushing it as far as possible with a lever (Fig. 2) so as to compress the spring in order to fit the screw **(3)** (Fig. 1).



7E01.6

## 6100 SERIES TRACTORS

**Rear axle - PTO clutch**

18. Clean the screw and smear it with Loctite 221 and tighten it with a ring spanner (Fig. 1).
19. Refit the intermediate shaft, the compound gear and the top link support. Carry out operations 80 to 82 and 85 to 98, section 7 A01.
20. Replace the left cover. Carry out operations 7 to 19, section 9 I02.
21. Check the operation of the clutch, the PTO brake and of the hydraulic lift.
22. Check for leaks :
  - at the joint faces (spool valve support, top link support, left side cover)
  - at the hydraulic connectors.

### C . Disassembly and reassembly of clutch

#### Disassembly

23. Remove the bolts (16).
24. Remove the clutch housing (15), the inner plates (17) and the outer plates (14).
 

**Note: The number of inner plates and outer plates varies according to the type of tractor.**

**Assembly A : 3 inner plates, 3 outer plates and 2 spacers (28) and (29) for 6110 - 6120.**

**Assembly B : 4 inner plates, 4 outer plates and 1 spacer (28) for 6130 to 6170.**

**Assembly C : 5 inner plates, 5 outer plates for 6180 and 6190**
25. Place the support housing (9) in a vice.
26. Remove the O-rings (3) and (6).
27. Remove the circlip (1).
28. Extract the ball bearing (2) with the sleeve (4) (Fig. 15).
29. Remove the seal rings (5) (Fig. 8). Extract the ball bearing (7) (Fig. 4).
30. Hold the spring (18) with the aid of a locally made tool (Fig. 5). For tool see page 8.
31. Remove the screws (24) and take off the washer (23) (Fig. 5). Gradually decompress the spring with the tool.
32. Remove the hub (21), the spring seat (19), the spring (18), the retainer (13) and the Belleville washer (12).
33. Remove the securing ring (20).
34. Extract the ball bearing (22).
35. Take out the piston (10).
36. Remove the O-rings (11), (25) and (26).

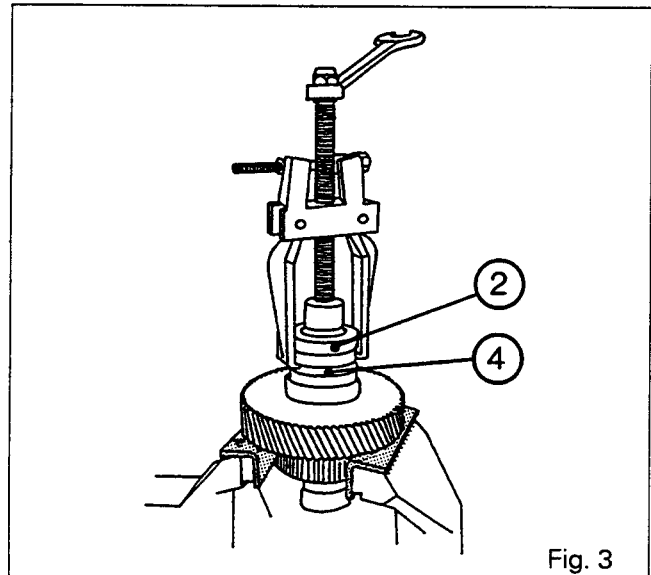

Fig. 3

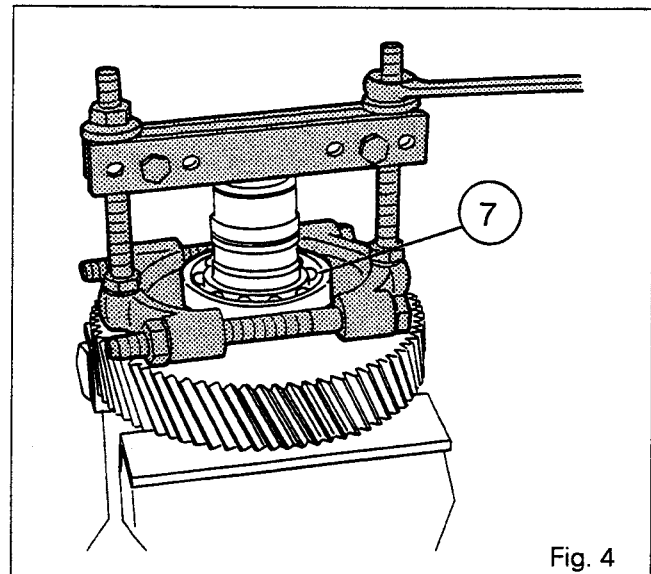

Fig. 4



## Rear axle - PTO clutch

7E01.7

### Reassembly

**Note:** The valve (8) is fitted in the support housing (9).

The sleeve (27), smeared with Loctite 648 (Fig. 6) is fitted with a press. If disassembly proves necessary, check when reassembling that the channel is not obstructed with Loctite.

Two pins (30) are fitted in the support housing (9) 5 mm from the face (Fig. 7).

37. Clean and check the parts. Replace those which are defective.
  38. Using a suitable device and a press, push the ball bearing (7) in until it meets the shoulder.
  38. Place the seal rings (5) in their grooves and join up the ends (Fig. 8). Ensure that they turn freely.
  40. Slide the sleeve (4) on to the seal rings, taking care not to damage them.
- Note:** Position the larger diameter end of the sleeve towards the ball bearing (7).
41. Using a suitable device and a press, push the ball bearing (2) in until it meets the shoulder of the support housing (9) (Fig. 9).
  42. Fit the circlip (1).
  43. Replace and lubricate the O-rings (11), (25) and (26).

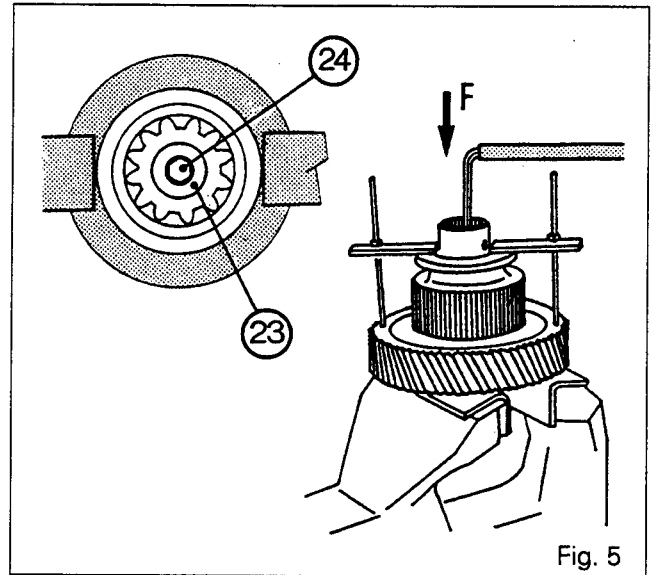

Fig. 5

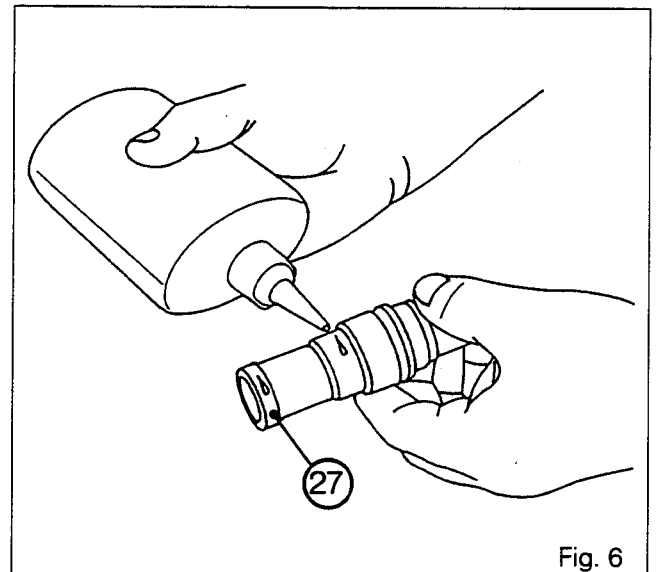

Fig. 6

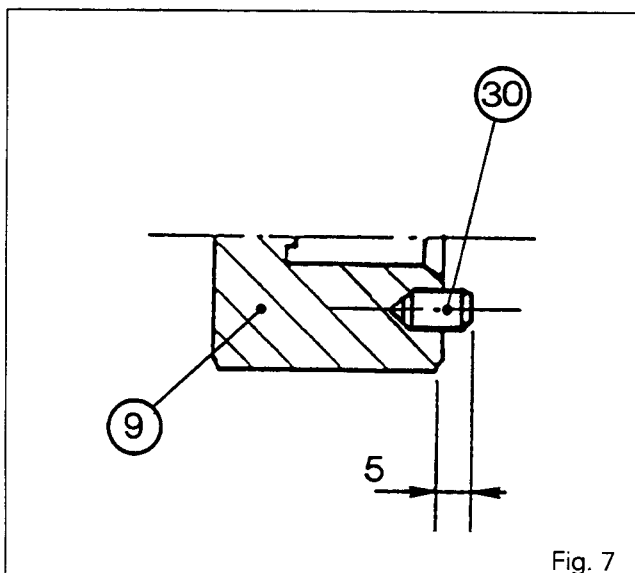

Fig. 7

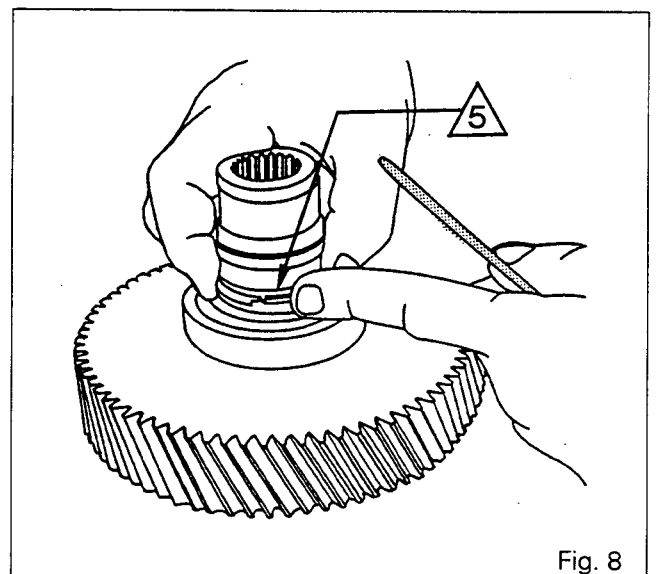

Fig. 8



# 6100 SERIES TRACTORS



7E01.8

## Rear axle - PTO clutch

- 44. Lubricate the sleeve (27) and the piston (10) and insert into the housing with a plastic mallet (Fig. 10).
  - 45. Using a suitable device and a press, insert the ball bearing (22) into the hub (21). Fit the securing ring (20).
  - 46. Refit the Belleville washer (12), the support (13), the spring (18), the spring seat (19) and the hub (21).
  - 47. Compress the spring (18) with the tool (Fig. 5). Mount the washer (23) and tighten the screw (24) smeared with Loctite 242 to a torque of 24 - 28 Nm.
  - 48. Place the spacers, the outer plates and the inner plates (according to the type) on the hub (21).
  - 49. Position the clutch housing (15) on the two pins (30). Fit the bolts (16) lightly smeared with Loctite 542 and tighten them to a torque of 24 - 28 Nm.
  - 50. Manually check that the inner plates and outer plates do not bind together.
  - 51. Lubricate and fit the O-rings (3) and (6).
- Note : The O-rings have different diameters.**

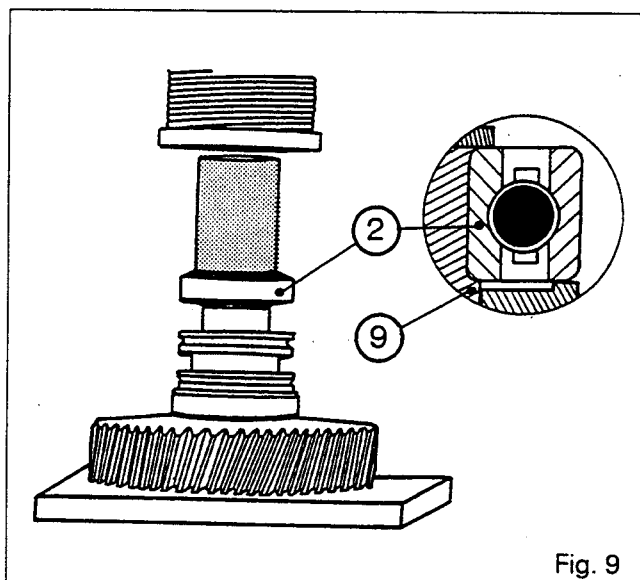

Fig. 9

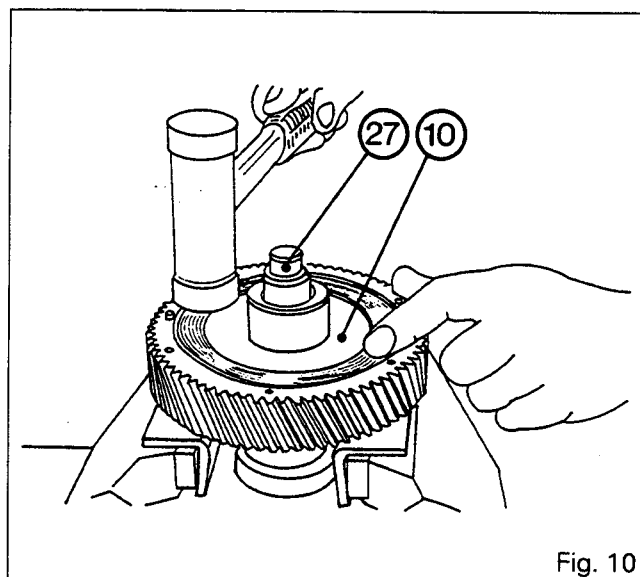

Fig. 10

### E. Service tool

Tool to be made locally (Fig 11)

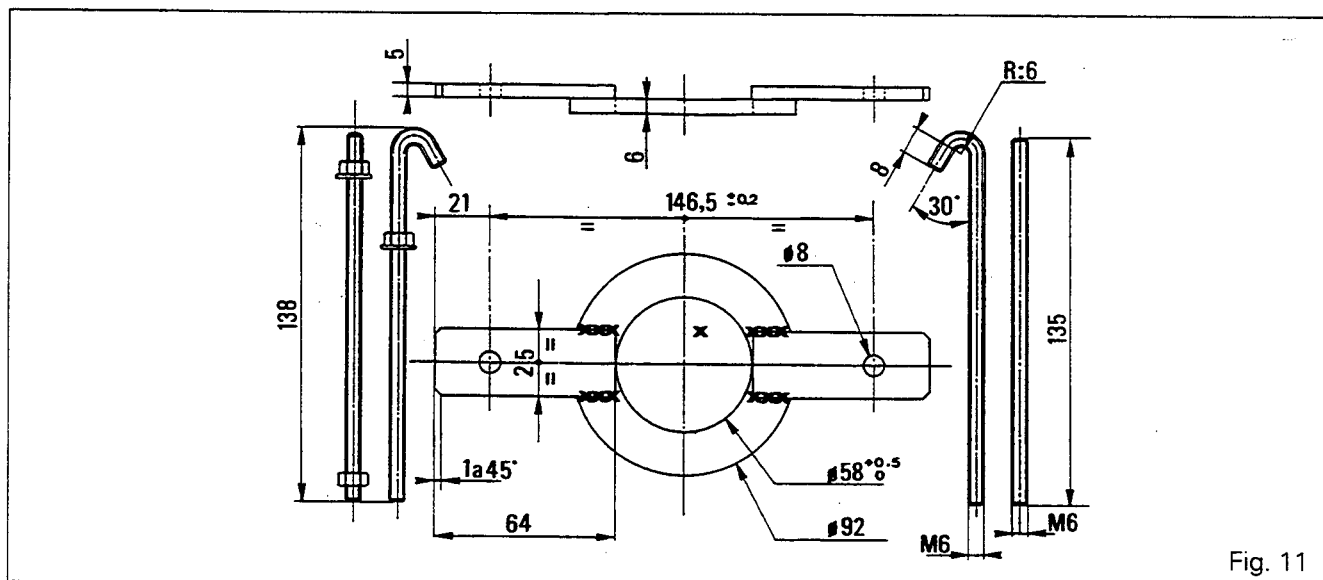

Fig. 11



## **8 . FRONT AXLE**

### **Contents**

- 8 A01 4 WD CLUTCH ASSEMBLY**
- 8 B01 FINAL DRIVE UNITS**
- 8 C01 DIFFERENTIAL**
- 8 D01 2 WD FRONT AXLE**
- 8 E01 STEERING COLUMN**
- 8 F01 BEARINGS**







6100 SERIES TRACTORS



**Front axle - 4 WD clutch assembly**

8A01.1

*8 A01 4 WD Clutch Assembly*

CONTENTS

- General _____	2
A. Removal of clutch assembly _____	5
B. Disassembly of clutch _____	6
C. Reassembly of clutch _____	6
D. Refitting of clutch assembly _____	7
E. Tools to be made locally _____	9



## 6100 SERIES TRACTORS

8A01.2

# Front axle - 4 WD clutch assembly



### General

The clutch assembly for the drive to the front axle is mounted in the lower part of the rear axle housing. An inspection cover placed under the housing provides access to the unit which comprises :

- A shaft (25) turning on two taper roller bearings mounted in the bore of the centre housing.
- A hydraulic clutch assembly mounted on the shaft.
- A transfer gear (15) centred on the shaft by a bush (43), driving the clutch plates (36).

The transfer gear (15) has helical teeth and engages constantly with the gear (7) fitted on the bevel drive pinion.

The shaft is fitted with shims [20] placed between the cap (22) and the cup (18) so as to obtain play of 0 to +0.10 mm.

### Operation

#### Disengaging

The 4WD solenoid valve sends oil at a pressure of 17 bar via a gallery in the centre housing, through bush (11) into the drilling in shaft (25).

The piston (30) is forced by oil pressure along hub (40) and pulls drum (42) which compresses the Belleville washers /34\ and /35\ releasing plates (36). The transfer gear (15) then runs freely on bush (43).

#### Engaging

With the solenoid valve releasing the oil pressure, the Belleville washers push back the drum (42) which through the plates locks up with transfer gear (15) and drives shaft (25). The returning oil is dumped back into the centre housing.

### List of parts

- (1) Sleeve
- (2) Double pin
- (3) Shaft
- (4) Double pin
- (5) Sleeve
- (6) Circlip
- (7) Gear
- (8) Plug
- (9) Needle roller bearing
- (10) Bolt
- (11) Bush
- /12\ Seal rings
- (13) Bearing cup
- (14) Bearing cone
- (15) Transfer gear
- (16) Clutch assembly
- (17) Cover
- (18) Bearing cup
- (19) Bearing cone
- [20] Shim(s)
- (21) O-ring
- (22) Cap
- (23) Circlip
- (24) Seal
- (25) 4WD drive shaft
- (26) Seal
- (27) Locking screw
- (28) Flange
- (29) O-ring
- (30) Piston
- (31) Circlip
- (32) O-ring
- (33) O-ring
- /34\ Belleville washer
- /35\ Belleville washer
- (36) Outer plate  
A : 4-plate clutch  
B : 5-plate clutch
- (37) Inner plate  
A : 4-plate clutch  
B : 5-plate clutch
- (38) Cover
- (39) Circlip
- (40) Hub
- [41] Shim(s)
- (42) Drum
- (43) Bush



6100 SERIES TRACTORS



Front axle - 4 WD clutch assembly

8A01.3

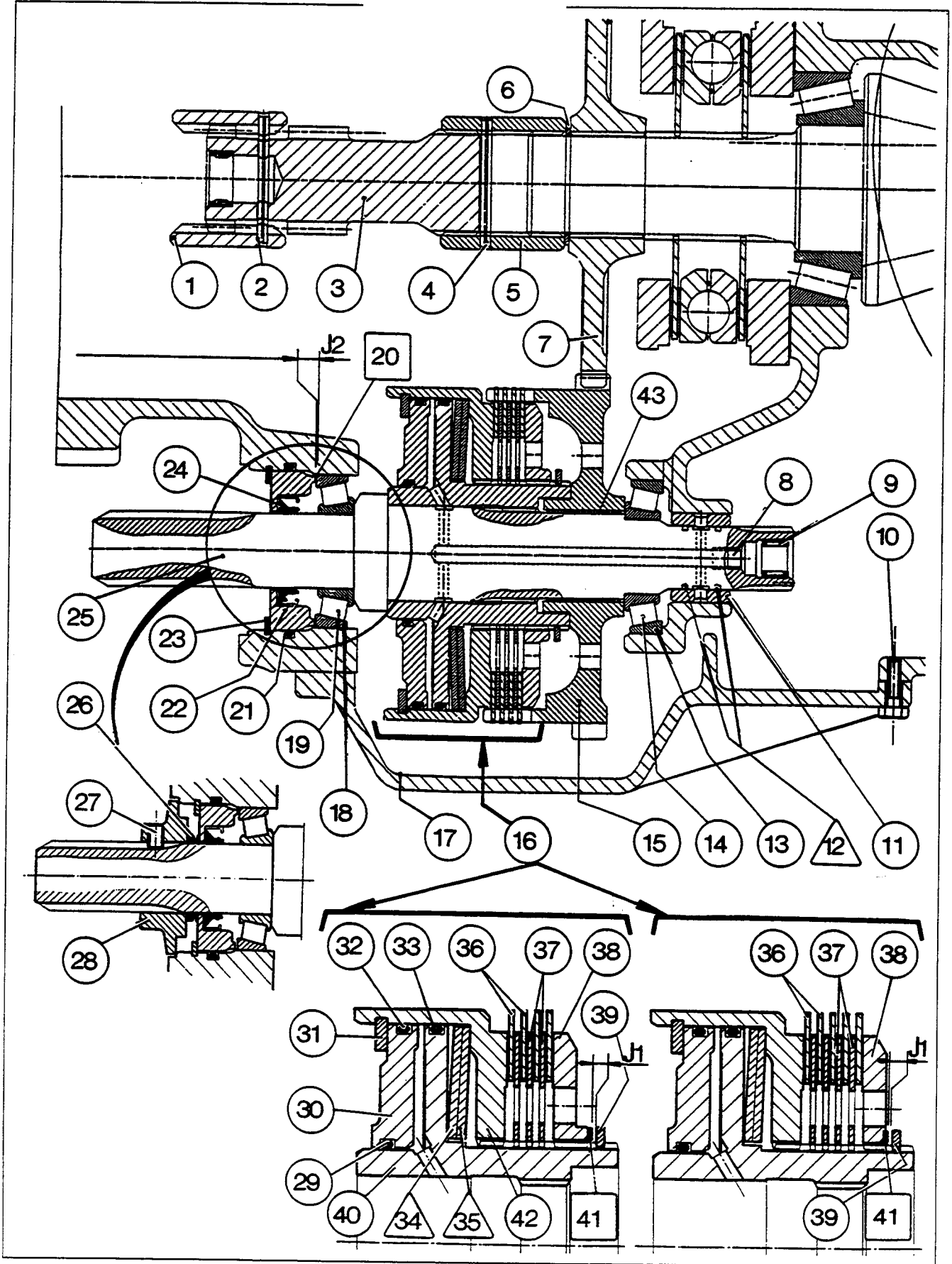



# 6100 SERIES TRACTORS



8A01.4

## Front axle - 4 WD clutch assembly

Exploded view

Rice field version

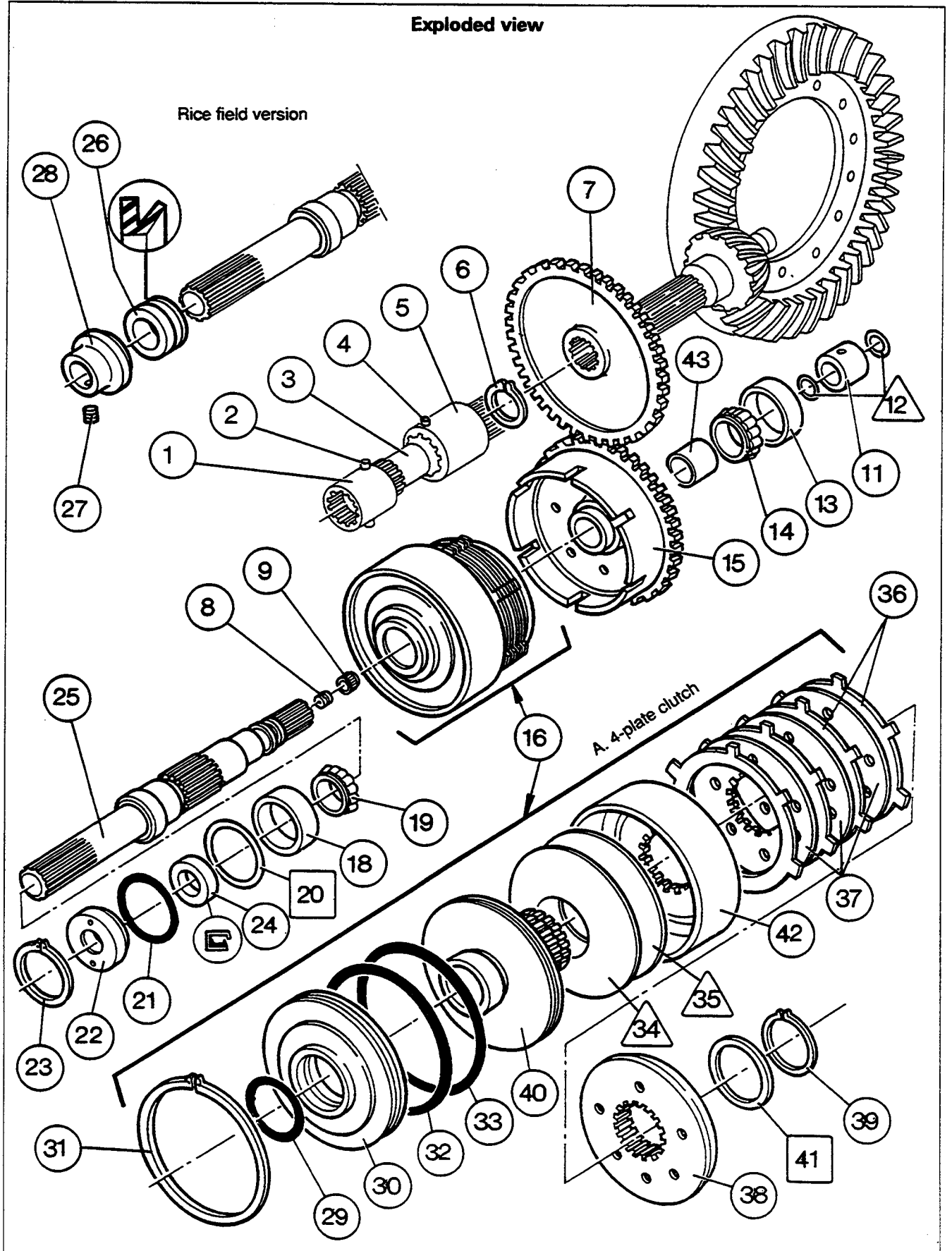



## A. Removal of clutch assembly

1. Immobilise the tractor. Drain the rear axle housing.
2. Disconnect the hoses for the front differential lock (plug the fittings). Remove the guard and the drive shaft. Remove the engine clutch lubricating tube fitted on the lower covers of the centre housing and gearbox housing.
3. Remove the bolts (10) and the cover (17).  
**Note : On tractors with a ground speed PTO (G.S. PTO), recover the spring (3), the plunger (2) and the retaining tube (1) (Fig. 1).  
On tractors equipped with a protector flange and rice field seal, remove the screw (27), the flange (28) and the seal (26).**
4. Remove the circlip (23).
5. Protect the splined section of the shaft (25). Extract the cap (22) with its seal (24) using the locally made tool (see section E). Remove the seal (24) (Fig. 2).
6. Remove the O-ring (21).
7. Remove the shims [20] and the cup (18).  
**Note: On tractors equipped with a G.S. PTO, set the control to the disengaged position.**
8. Remove the shaft assembly (25) and bearing cone (19), whilst keeping the clutch assembly (16) and transfer gear (15) together.
9. Remove the clutch assembly (16) with the transfer gear (15) and bearing cone (14).
10. Using the locally made tool (see section E), remove the bush (11) (Fig. 3). This tool is essential for tractors with G.S. PTO. If necessary, also remove the cup (13) with a suitable extractor.

**If removing the gear (7), it is necessary to remove the right-hand hydraulic cover.**

11. Raise the relevant side of the tractor with a jack.
12. Place a stand in position and remove the wheel.
13. Remove the right-hand hydraulic cover.  
Carry out operations 2 to 14, section 9 101.

### Tractors without creeper gears

14. Drive out the double pins (2) and (4) of the coupling sleeves (1) and (5).
15. Slide the sleeves towards each other on the shaft (3) and remove the shaft - sleeve assembly.
16. Remove the circlip (6) and the gear (7).

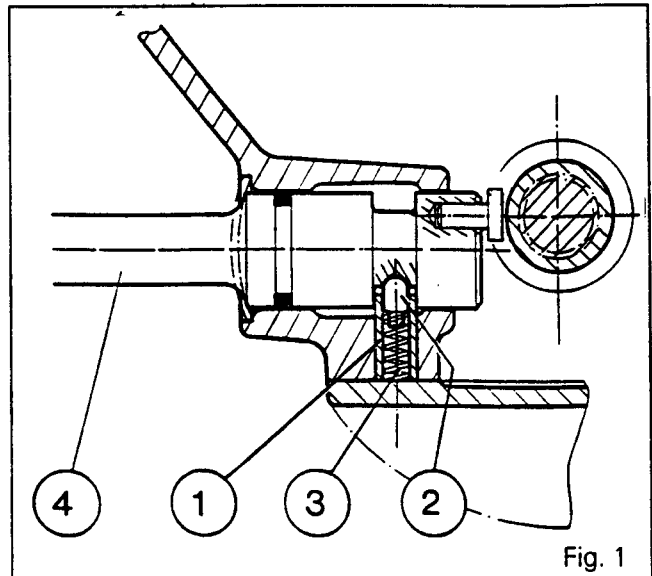

Fig. 1

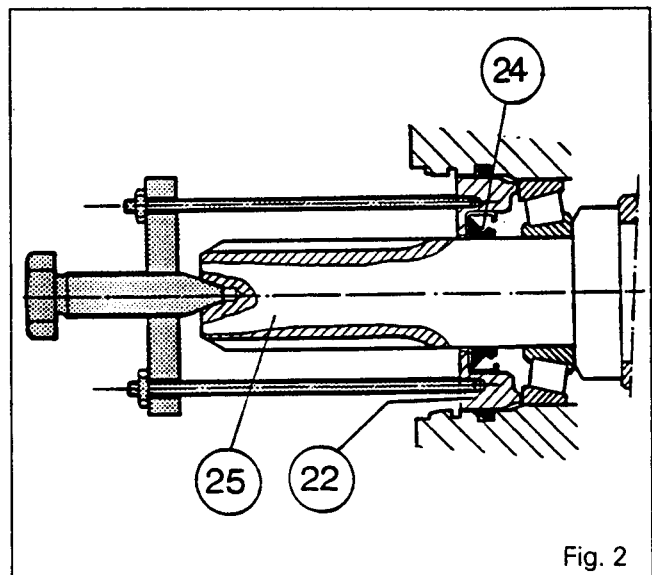

Fig. 2

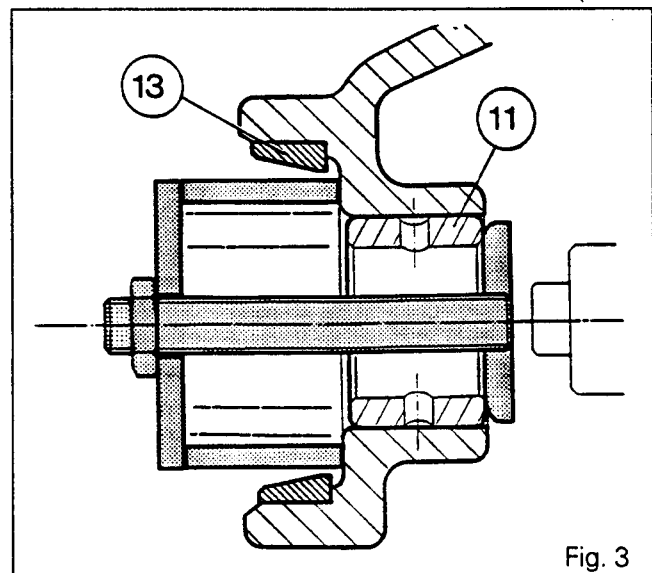

Fig. 3



8A01.6

## 6100 SERIES TRACTORS



## Front axle - 4WD clutch

Tractors with creeper gears Tractors with creeper gears

17. See Section 5 D01, Part A.

18. Remove the circlip (6) and remove the gear (7).

## B . Disassembling the clutch

19. Separate the bell gear (15) from the clutch assembly (16).

20. Take off circlip (31).

21. Remove the cover (30).

22. Remove the O-rings (29) and (32).

23. Using a press and a suitable fixture, compress the Belleville washers /34\ and /35\, (Fig. 4).

24. Remove circlip (39) and the shim or shims [41] (Fig. 4).

25. Remove the fixture.

26. Remove the cover (38), discs (36) and backing plates (37).

**Note: The cover (38) and the installation of the discs and backing plates differ according to the reference of the clutch and the type of tractor.**

**Installation A: 4 discs and 3 backing plates, tractors 6110 to 6170 with forward motion proportional PTO**

**Installation B: 5 discs and 4 backing plates, tractors 6180 and 6190 without forward motion proportional PTO, and tractors 6110 to 6190 with forward motion proportional PTO**

27. Separate the hub (40) from the bell (42).

28. Remove the O-ring (33).

29. Remove the Belleville washers /34\ and /35\.

### Disassembling the shaft

30. Remove the two rings /12\.

31. Extract the cone (19) using a press and a suitable fixture.

32. Extract the needle roller bearing (9). Remove the plug (8).

### Reassembling the shaft

Check that the channel in the shaft is not obstructed.

33. Tighten the plug (8) after smearing it with Loctite 542.

34. Fit the needle roller bearing (9) 2.5 mm back from face F (see Fig. 5).

35. Fit the bearing cone (19) fully home on the shoulder of the shaft (25).

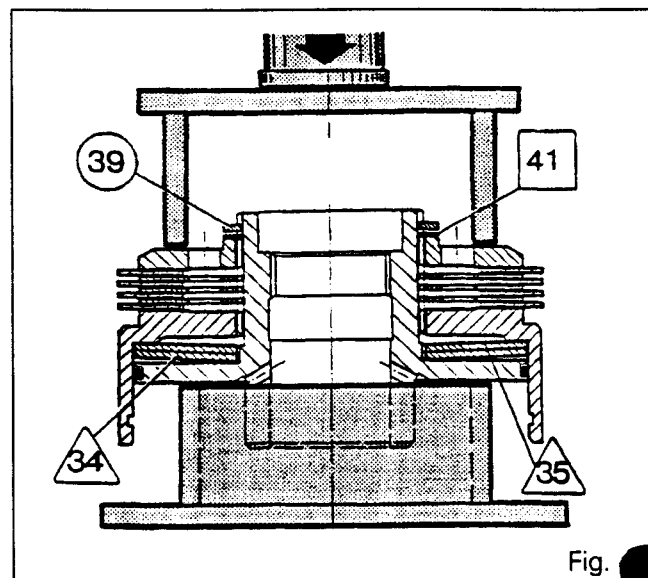

Fig.

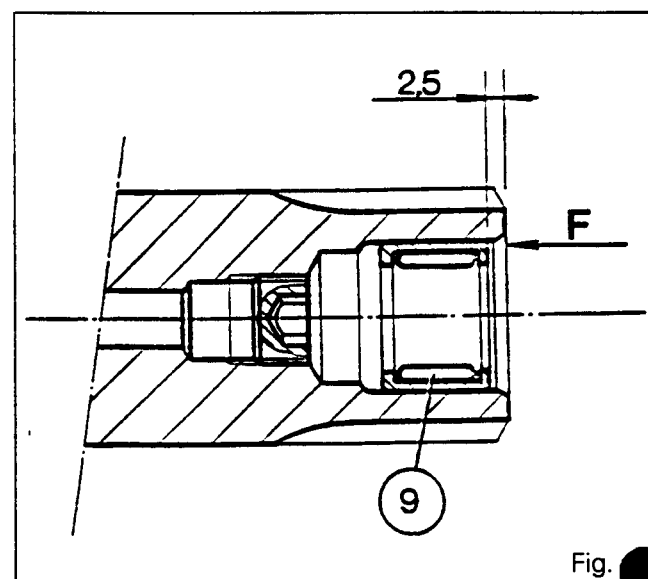

Fig.



## C . Reassembling the clutch

36. Check and clean the parts, and replace any that are faulty.  
Check that the 17 bar channel in the hub (40) is not obstructed.
37. Position the Belleville washers /35\ and /34\ in the bell (42) (see Fig. 6).
38. Lubricate and fit the O-ring (33) on the hub (40).
39. Position the hub (40) in the bell (42) so that it bears against the Belleville washers.
40. Fit the discs (36), aligning the lugs. Fit the backing plates (37). Install the cover (38).

**Note : Discs (36) with thicker reinforcement (2 mm instead of 1.8 mm) were introduced on tractors from the following serial number onwards:**

**Tractors with proportional PTO**

- D157019 6170

- D158004 6180

**Tractors without proportional PTO**

- D328051 6110 to 6160

**Tractors of type 6190 with or without proportional PTO**

41. **Shimming J1** (Fig. 7)

**Note : On 6100 tractors, the 4WD clutch can be of the standard or heavy duty type.**

The type of clutch can be identified by checking the last three figures marked on the Belleville washers. See the table opposite.

Using a press and a suitable fixture (see Fig. 4), apply a load of 2,000 daN so as to fully compress the Belleville washers /35\ and /34\.

Fit circlip (39). Using a set of shims, measure the play **X** between the cover (38) and the circlip (39). Select the shim or shims [41] in order to obtain a play of: **J1 = 0.9 to 1.1 mm**.

**Note : Prior the above-mentioned serial number, the value for shimming J1 was between 1.5 and 1.7 mm.**

42. Remove circlip (39).
43. Position the shim or shims selected in procedure 41 between the cover and the circlip (with the splined shim on the same side as the circlip).
44. Refit circlip (39).
45. Lubricate and fit O-rings (32) and (29) on the cover (30) and reinstall the cover.
46. Refit circlip (31).
47. Fit the clutch assembly (16) on the bell gear (15).  
**Note: Bush (43) is force-fitted in the bell gear (15) and then counterbored.**

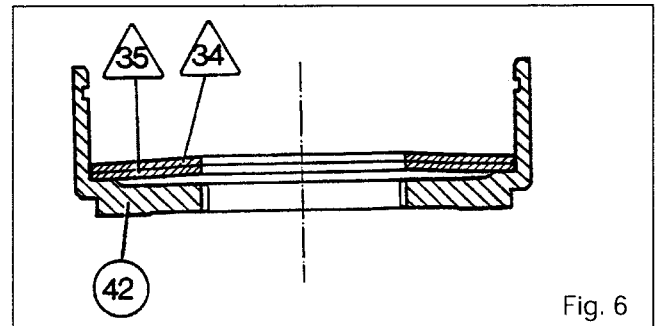

Fig. 6

	Standard clutch	Heavy duty clutch
Washers /34\-/35\ Discs (36) Splined shims [41] cannelées	3619147M01 2 ± 0.05 mm thick	3619473M01 1.4 or 1.7 mm thick

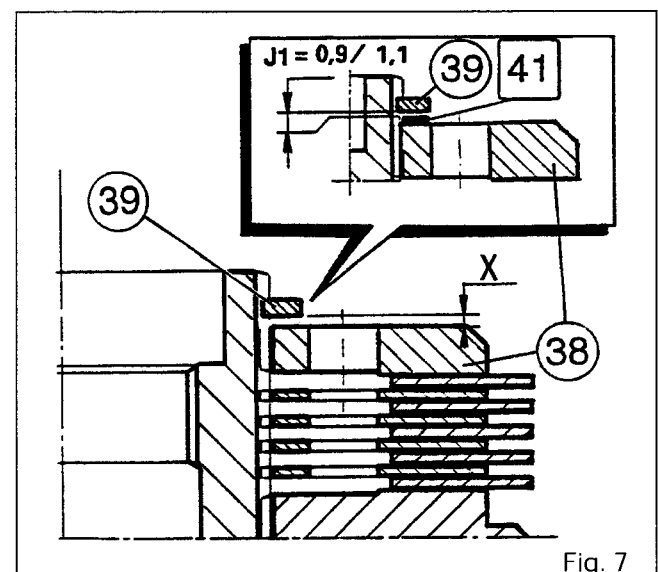

Fig. 7





8A01.8

## 6100 SERIES TRACTORS

**Front axle - 4WD clutch****D . Refitting the clutch assembly**

**If gear (7) was removed:**

**Tractor without creeper gears**

48. Reinstall the gear (7).
49. Position the circlip (6).
50. Reinstall the connecting shaft and the coupling sleeves. Carry out procedures 14 and 15 in reverse order. Replace the double dowels.

**Tractors with creeper gears**

51. Reinstall the gear (7).
52. Position the circlip (6).
53. See Section 5 D01, Part A.
54. Reinstall the right-hand hydraulic cover.

Carry out procedures 15 to 17 in Chapter 9 I01.

55. Fit cup (13), (if it was removed).
56. Use a locally manufactured drift (see Part E) to fit the bush (11) so that the bush is located 4 to 5 mm back from the mating face on the cup (13) (Fig. 8). Line up a hole in bush with the clutch feed channel in the housing.
57. Fit the seal (24) in the cap (22).

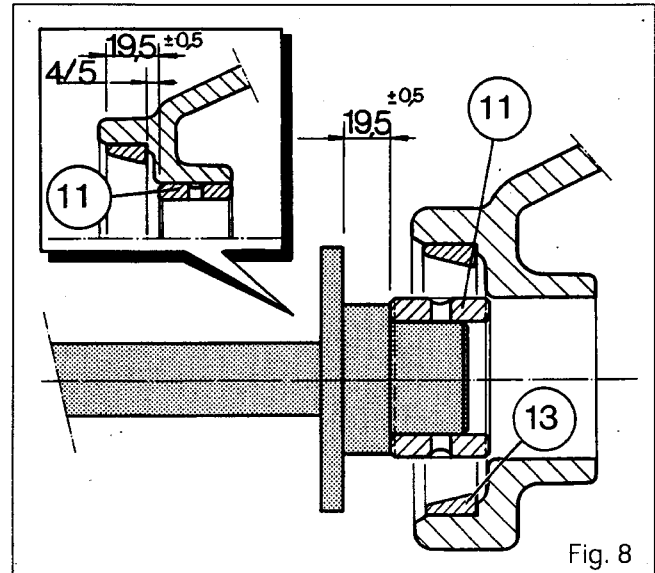



## Front axle - 4WD clutch

58. Fit the cone **(14)**, the shaft **(25)** and cup **(18)**, so as to seat the cones correctly in the bearing cups and obtain the following play:

**J2 = 0 to 0.10 mm.**

59. Protect the splines on the shaft.
60. Fit the bearing **(22)** and circlip **(23)**.
61. Position the tip of a dial gauge on the end of the shaft **(25)** (Fig. 9).
62. Pull on the shaft, turning it alternately to the right and left in order to seat the cones correctly in the cups.
63. Reset the dial gauge.
64. Repeat procedure 62, pushing on the shaft.
65. According to the play measured, select the required thickness of shims **[20]** required to obtain J2.
66. Remove the circlip **(23)**, the cap **(22)**, cup **(18)** and shaft **(25)**.
67. Position the sealing rings **/12** in the grooves in the shaft **(25)** and secure their ends. Check that they rotate freely.
68. Place cone **(14)** in cup **(13)**. Insert the shaft **(25)** after positioning the clutch assembly **(16)** and the bell gear **(15)** in the housing.
69. Fit cup **(18)** and the shim or shims selected in procedure 65, after coating them with grease.
70. Fit the O-ring **(21)** in the groove in the housing.
71. Fit the cap **(22)** and circlip **(23)**. Remove the protection from the splines on the shaft.
72. On tractors with heavy duty sealing: grease and install the seal **(26)** with its lip facing the cap **(22)**. Remove the protection.
73. Fit the flange **(28)** and ensure that there is functional play between the flange and the housing.
74. Tighten bolt **(27)** after smearing it with Loctite 241.
75. Clean and degrease the mating faces on the cover **(17)** and on the housing.
76. Smear the mating face on the cover with a sealing compound (Master Joint 510 or equivalent).
77. Screw in two opposite locating studs on the housing.
78. On tractors fitted with a proportional PTO: check the position of lever **(4)**. Fit the retaining tube **(1)**, the locking finger **(2)** and the spring **(3)** (Fig. 1).
79. Reinstall the cover **(17)**.
80. Remove the locating studs. Fit and tighten bolts **(10)** to a torque of between 130 and 170 Nm.

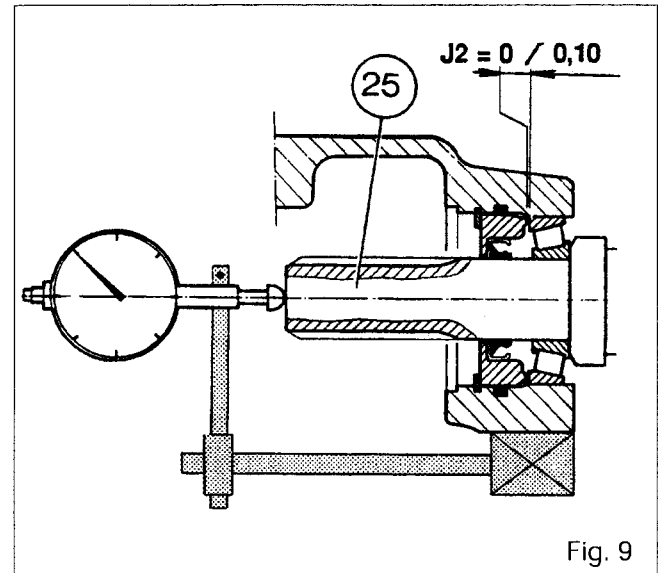

Fig. 9

81. Smear the two sleeves with "Anti-Seize" grease of equivalent.  
Refit the 4WD drive shaft and the guard. Reconnect the two hoses for the front differential lock.  
Refit the engine clutch lubrication tube.
82. Top up the oil in the rear axle and remove the shims.
83. Check the operation of the clutch and the adjustment of the proportional PTO control (if fitted).
84. Check for leaks on:
  - . the cover mating face under the rear axle housing,
  - . the right-hand hydraulic cover (if it was removed),
  - . the hydraulic unions.



8A01.10

# 6100 SERIES TRACTORS



## Front axle - 4WD clutch

### E . Tools to be manufactured locally

#### 1 . Cap extractor

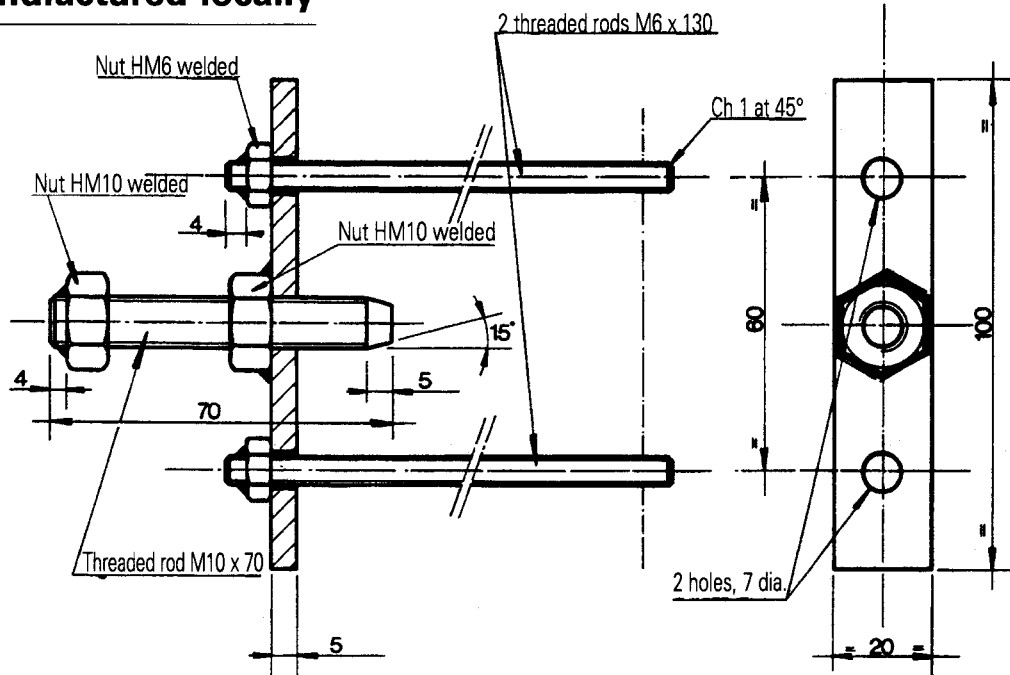

#### 2 . Bush extractor

Washer MF 3385963 M01

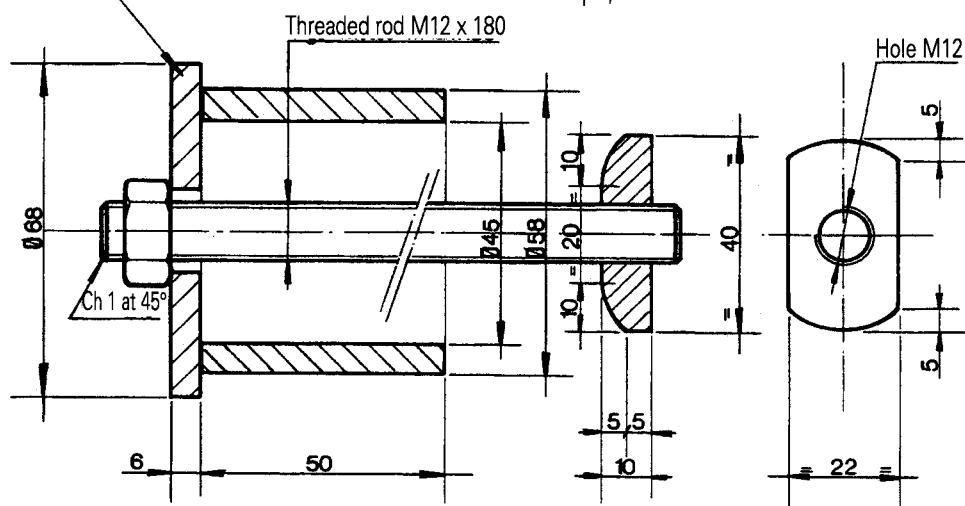

#### 3 . Bush fitting drift

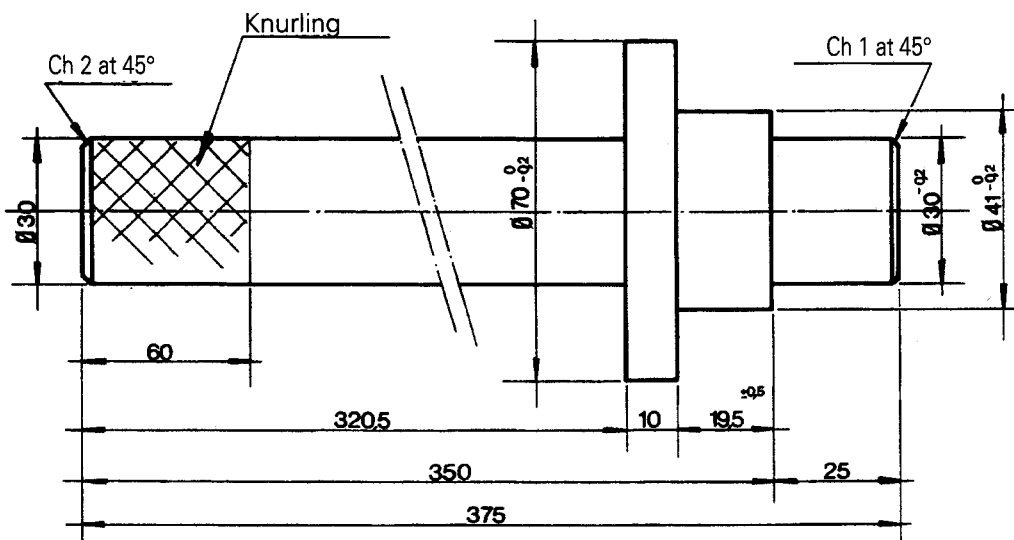



## **Front Axle - Final drive units**

### *8 B01 Final drive units*

#### CONTENTS

-	<b>General</b> _____	<b>2</b>
A.	<b>Removing the planetary carrier, sun gear and ring gear</b> ____	<b>5</b>
B.	<b>Refitting the ring gear, sun gear and planetary carrier</b> _____	<b>7</b>
C.	<b>Disassembling the wheel hub</b> _____	<b>7</b>
D.	<b>Reassembling the wheel hub</b> _____	<b>8</b>
E.	<b>Replacing a wheel stud</b> _____	<b>9</b>
F.	<b>Disassembling the swivel housing</b> _____	<b>9</b>
G.	<b>Reassembling the swivel housing</b> _____	<b>10</b>
H.	<b>Removing and refitting the universal drive shaft</b> _____	<b>12</b>
I.	<b>Service tools</b> _____	<b>14</b>



8B01.2

## 6100 SERIES TRACTORS

**Front Axle - Final drive units****General**

6100 tractors are fitted with the following four categories of front axle:

- AG 85 (6110 to 6140)
- AG 105 (6150 and 6160)
- AG 125 (6170 and 6180)
- AG 155: 6190

The relevant category and serial number is indicated on a plate riveted onto the right-hand side of the axle housing.

**Description**

The final drive assembly consists of a swivel housing **(47)** articulated on the front axle housing by means of two swivels **(7)** and **(11)**. The wheel hub **(22)** turns on two taper roller bearings whose cups **(23)** and **(19)** are force-fitted in the hub. The cones **(18)** and **(25)** are also force-fitted.

The bearings **(18)**, **(19)**, **(23)** and **(25)** are not adjustable. The parts are manufactured in accordance with machining tolerances such that no adjustment or shimming is required. The drive from the front differential is transmitted to the wheel hub via the universal drive shaft assembly **(10)**, the sun gear **(28)**, the planet gears **(38)** and the ring gear **(44)**. The ring gear is held by two retaining rings **(24)** and **(26)** on the ring gear carrier **(42)**. The ring gear carrier is force-fitted on the swivel housing **(47)** and locked by the centre nut **(27)**. For greater efficiency, the seals are equipped with double lips.

Tight sealing is ensured between the hub and the swivel housing by seal **(45)** and between the universal drive shaft and the axle housing by seal **(8)** and protective bush **(40)**. Seal **(45)** is identical on axles AG 85 and AG 105. A different seal is fitted on axles AG 125 and AG 155.

Tight sealing is ensured between the drive assembly and the swivel housing by seal **(16)** and on swivel bearings in the housing by O-rings **(6)** and **(12)**.

**Service tools (See Section I)**

MF451B: Swivel extractor

MF451B3: End fitting for extractor M18

3376880M1: Socket for ring gear carrier nut (AG 85 and AG 105)

3378028M1: Socket for ring gear carrier nut (AG 125 and AG 155)

3378039M1: Ring gear carrier and seal fitting tool (AG 125 and AG 155)

3378038M1: Extractor for ring gear carrier **(42)**

3378040M1: Fitting bush for seal **(45)** (AG 85 and AG 105)

3378056M1: Fitting bush for seal **(45)** (AG 125 and AG 155)

3378058M1: Ring gear carrier and seal fitting tool (AG 85 and AG 105)

**List of parts**

- (1)** Bolts
- (2)** Cover
- (3)** Shims
- (4)** Cup
- (5)** Cone
- (6)** O-ring
- (7)** Swivel pin
- (8)** Seal
- (9)** Bush
- (10)** Universal drive shaft
- (11)** Swivel pin
- (12)** Seal
- (13)** Cone
- (14)** Cup
- (15)** Cover
- (16)** Seal
- (17)** Bush
- (18)** Cone
- (19)** Cup
- (20)** Seal
- (21)** Plug
- (22)** Wheel hub
- (23)** Cup
- (24)** Retaining ring
- (25)** Cone
- (26)** Retaining ring
- (27)** Nut
- (28)** Sun gear
- (29)** Circlip
- (30)** Thrust washer
- (31)** Bush
- (32)** Grease nipple
- (33)** Bolt
- (34)** Circlip
- (35)** Needles
- (36)** Planetary carrier
- (37)** Plate
- (38)** Planet gear
- (39)** Plate
- (40)** Protective bush
- (41)** Planet gear pin
- (42)** Ring gear carrier
- (43)** Wheel stud
- (44)** Ring gear
- (45)** Seal
- (47)** Swivel housing
- (48)** Steering lock screw
- (49)** Nut
- (52)** Axle housing
- (53)** Plate
- (54)** Dowel
- (55)** Bolt



# 6100 SERIES TRACTORS



## Front Axle - Final drive units

8B01.3

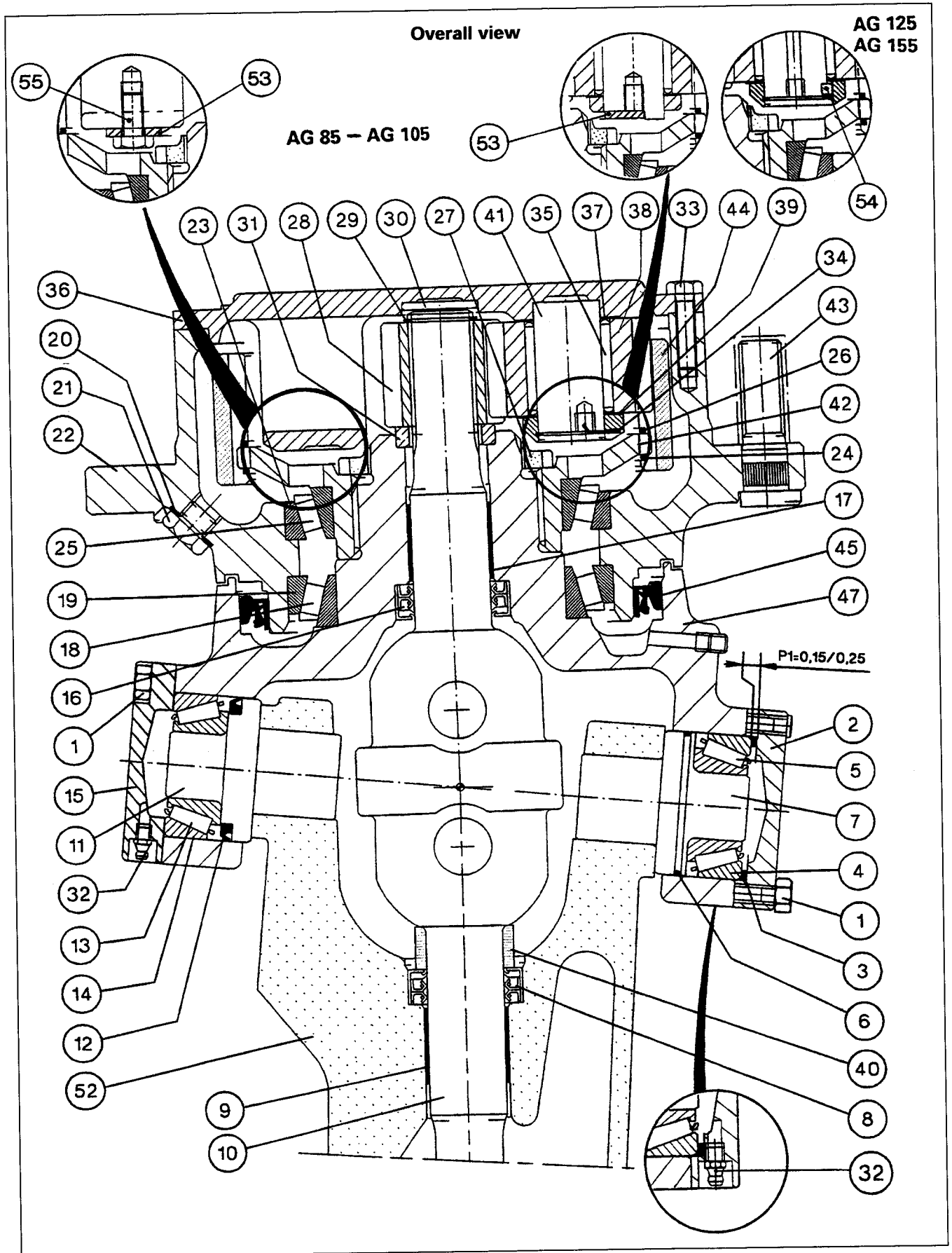



8B01.4

# 6100 SERIES TRACTORS



## Front Axle - Final drive units

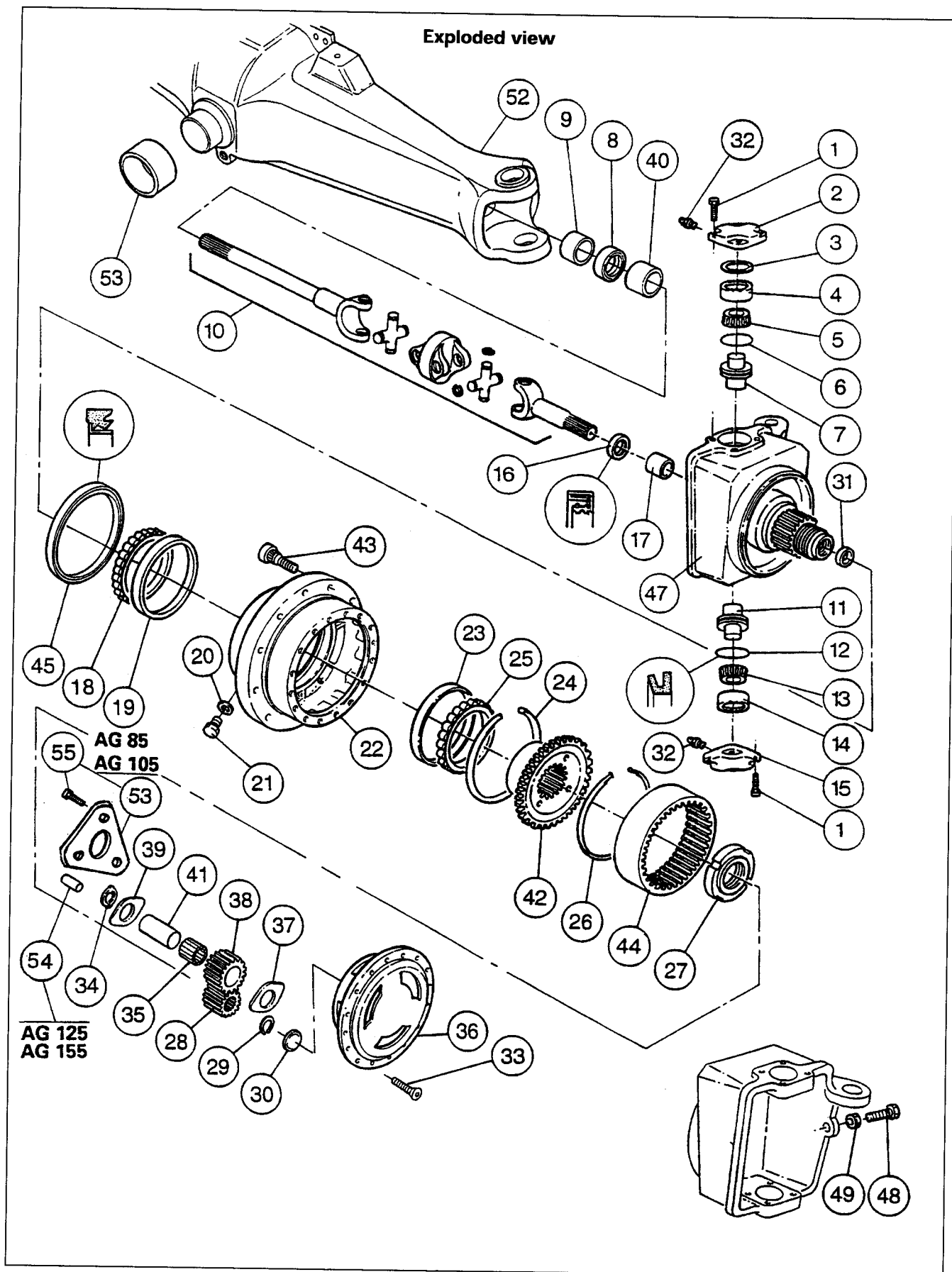



## Front Axle - Final drive units

**Note:** The work procedure is identical for the final drive units of front axles AG 85, AG 105, AG 125 and AG 155.

### A . Removing the planetary carrier, sun gear and ring gear

1. Chock the rear wheels. Apply the handbrake.
2. With the 4WD clutch engaged and the tractor stationary, lift both front wheels so that the hub (22) turns freely. Install stands..
3. Remove the wheel on the relevant side.
4. Drain the final drive unit.
5. Remove the bolts (33).
6. Remove and detach the planetary carrier with the thrust washer (30).
7. Remove the circlip (29) and the sun gear (28).
8. To avoid damaging the thread on the swivel housing (47), it is advisable to unlock nut (27) properly and to loosen it with socket MF 3376880M1 (axles AG 85 and AG 105) or 3378028M1 (axles AG 125 and AG 155) (Fig. 1). Fit a sling on the hub (22). Remove the hub along with the ring gear carrier (42) and ring gear (44) using extractor 3378038M1 (Fig. 2) and the sleeve suitable for the relevant category of axle (see Part I).

**Note:** Smear the cone and bolt on the extractor with graphite grease. Remove the retaining rings (24) and (26) from the ring gear carrier assembly. On the ring gear carrier assembly (42), separate the gear (44) from the ring gear carrier.

Disassembling the planetary carrier (Fig. 3)

**Note:** A modification regarding the locking of the planet gear pins was introduced as from the following serial numbers:

- D292046 Axle AG 85
- D333018 Axle AG 105

The planet gear pins (41) (Fig. 3B) are locked in place by means of a plate (53) mounted on the planetary carrier (36) by means of bolts (55).

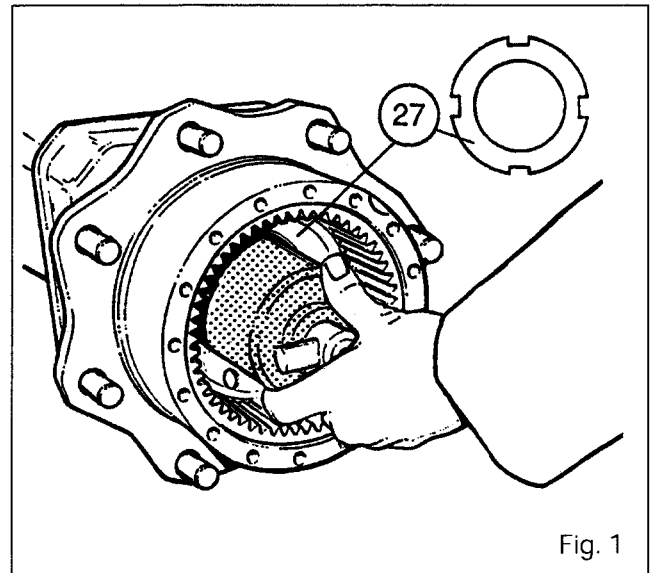

Fig. 1

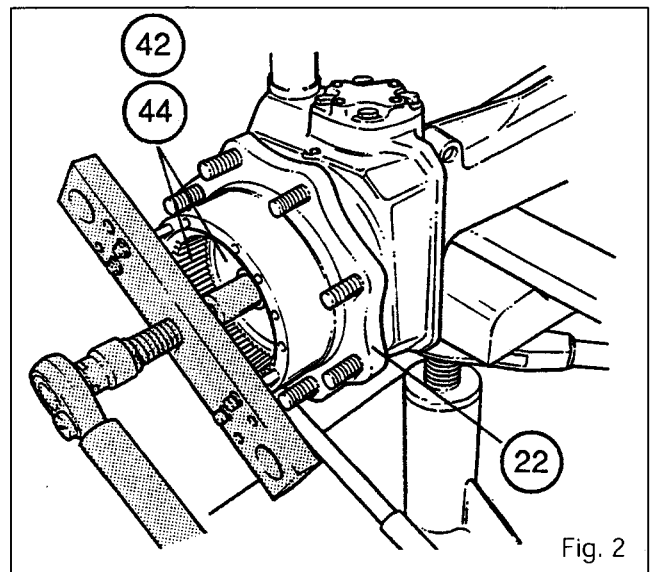

Fig. 2

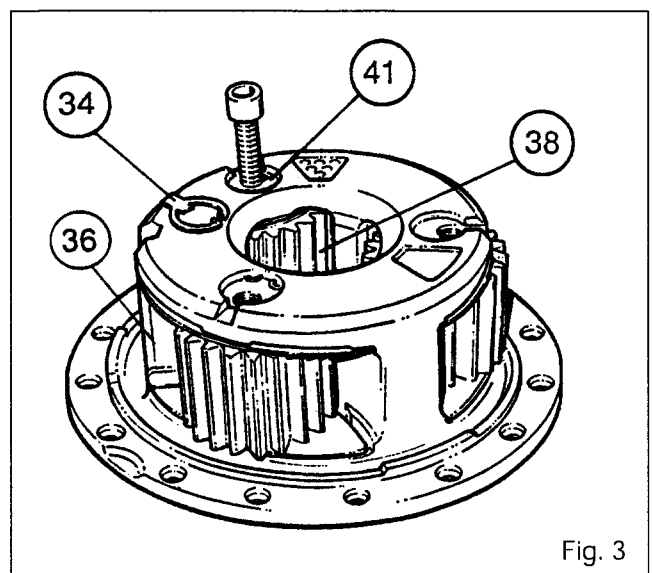

Fig. 3





8B01.6

## 6100 SERIES TRACTORS

**Front Axle - Final drive units****- E326028 Axle AG 125**

**the planet gear pins (41) (Fig. 3A) are locked in place by means of a dowel (54) secured by a circlip (34).**

**On axles of type AG 155 (6190), the planet gear pins are fitted in the same way as on AG 125 axles (Fig. 3A).**

9. Place the planetary carrier (36) on a bench.
10. Remove the circlip (34), the dowels (54) or the bolts (55) and plate (53), (according to the option fitted).
11. Drive out the planet gear pins (41) with a bolt (Fig. 3) (axles prior to the above-mentioned serial numbers), and remove the planet gears (38). Recover the needles (35) and the plates (37) and (39).

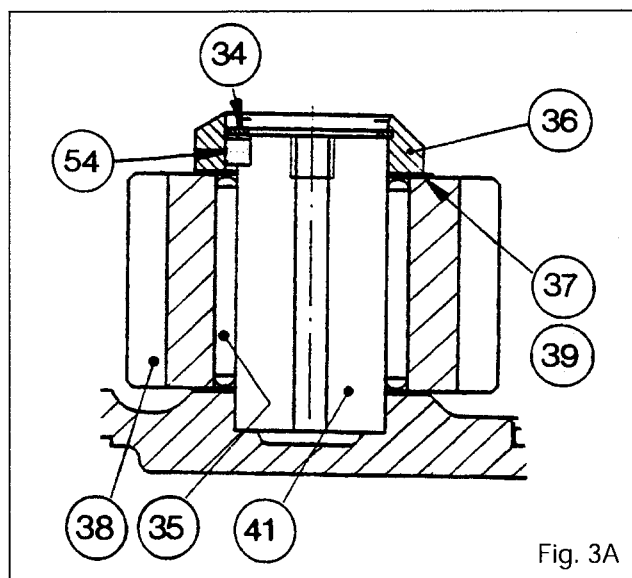

Fig. 3A

**Reassembling the planetary carrier**

12. Clean and check the parts, and replace any that are faulty.
13. Coat the needles with bearing grease and position them in each planet gear (38).
14. Fit the prepared planet gears in the planetary carrier (36).
15. Centre the planet gears and the plates. Position and fit the gear pins (41), with the tapped holes facing the notches on the planetary carrier as shown. Fit the circlips (34) (Fig. 3), (prior to the above-mentioned serial numbers).

**Special points:**

Fig. 3A: Check that the circlips (34) are positioned correctly.

Fig. 3B: Lightly coat the bolts (55) with Loctite 270 and tighten them to a torque of between 20 and 25 Nm.

16. Manually check the end play and rotation of the planet gears.

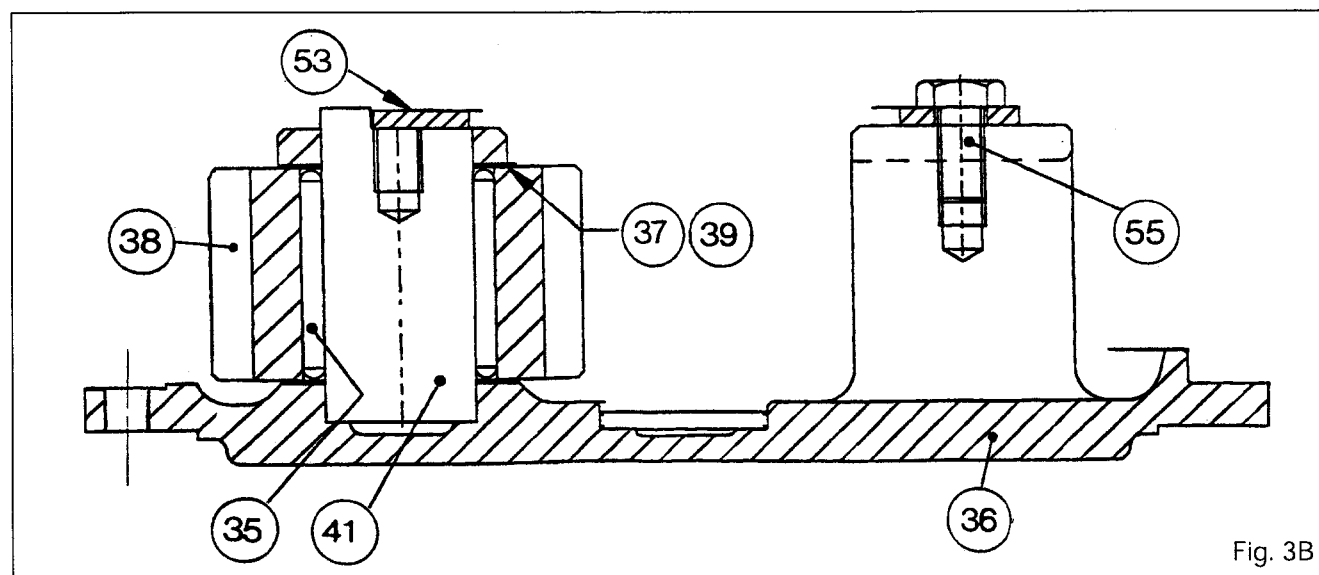

Fig. 3B



## Front Axle - Final drive units

### B . Refitting the ring gear, sun gear and planetary carrier

17. Assemble the ring gear **(44)** on the ring gear carrier **(42)** with the retaining rings **(24)** and **(26)**, making sure they are correctly positioned in their recesses.
18. Fit the assembly comprising the hub **(22)** and the ring gear carrier **(42)** fitted with the ring gear **(44)**. Carry out procedures 37 and 38.
19. Manually check the rotation of the hub **(22)**.
20. Fit the nut **(27)** coated with Loctite 270 and tighten it to a torque of 400 to 450 Nm.
21. Lock the nut by folding its collar into the groove.
22. Fit the sun gear **(28)** and the circlip **(29)**.
23. Coat the mating face on the planetary carrier with a sealing compound (Loctite 510 or equivalent).
24. Check that the thrust washer **(30)** is in place.
25. Refit the planetary carrier. Tighten the bolts **(33)** to a torque of 70 to 85 Nm.
26. Turn the wheel hub so that the filler plug is in the horizontal position. Top up the final drive unit with oil. Refit the plug **(21)** with its seal **(20)**.
27. Refit the wheel. Remove the stands and the trolley jack. Tighten the nuts to the following torques:
  - axles AG 85 - AG 105: 400 to 450 Nm,
  - axle AG 125:
    - . 800 to 850 Nm up to serial number: D152009,
    - . 640 to 680 Nm as from serial number: D152010,
  - axle AG 155: 640 to 680 Nm.
28. Remove the chocks and release the handbrake.
29. Carry out road test on the front axle. Check the mating face on the planetary carrier and the filler plug for leaks.

### C . Disassembling the wheel hub

30. Remove the planetary carrier. Carry out procedures 1 to 6.
31. Remove the circlip **(29)** and the sun gear **(28)**.
32. To avoid damaging the thread on the swivel housing **(47)**, it is advisable to unlock nut **(27)** properly and to loosen it with the socket (Fig. 1):
  - 3376880M1: axles AG 85 and AG 105,
  - 3378028M1: axles AG 125 and AG 155.
33. Fit a sling on the hub **(22)**. Remove the hub along with the ring gear carrier **(42)** and ring gear **(44)** using extractor 3378038M1 (Fig. 2) and the sleeve suitable for the relevant category of axle (see Part I).
 

**Note: Smear the cone and bolt on the extractor with graphite grease.**
34. If necessary, extract the cones **(18)** and **(25)**. Remove the cups **(19)** and **(23)**.



8B01.8

## 6100 SERIES TRACTORS

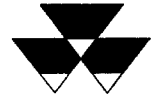
**Front Axle - Final drive units****D . Reassembling the wheel hub**

35. Clean and check the parts, and replace any that are faulty.
36. If the cones (18) and (25) and cups (19) and (23) are replaced, fit the new cones (18) and (25) in their respective positions and the cups on the wheel hub.

**Note: The cones (18) (25) and the cups (19) (23) must mandatorily be N series (tolerance on width = 0.1 instead of 0.2). The shimming of these bearings is determined on the basis of the machining tolerances of the swivel housing (47), the hub (22) and the ring gear carrier (42). It is possible to replace each part separately. If the hub (22) does not rotate correctly after fitting, the faulty part must be identified.**

37. Use the following method to fit the ring gear carrier (42) with the hub (22) in order to guide the hub (22) correctly on the seal (45).

**Method:**

38. Lubricate the splines on the swivel housing (47). Use three or four flanges ("B"), (manufactured locally according to the category of axle) screwed in diametrically opposite positions in the holes in the hub. Attach the ring gear carrier (42) to the hub (22) (Fig. 4).

Fit the ring gear carrier and hub assembly (Fig. 5) to make contact between the ring gear carrier and the swivel housing, using the following fitting tools:

- 3378039M1: axles AG 125 and AG 155,
- 3378058M1: axles AG 85 and AG 105.

**Note: Fully tighten tool A (Part I) on the swivel housing. Coat nut D and the mating face with graphite grease.**

39. Manually check the rotation of the hub (22).
40. Clean the thread on the nut on the swivel housing. Coat the nut (27) with Loctite 270 and tighten it to a torque of 400 to 450 Nm.
41. Lock the nut by folding its collar into the groove on the housing.
42. Refit the sun gear (28) and the circlip (29).
43. Refit the planetary carrier. Carry out procedures 23 to 29.

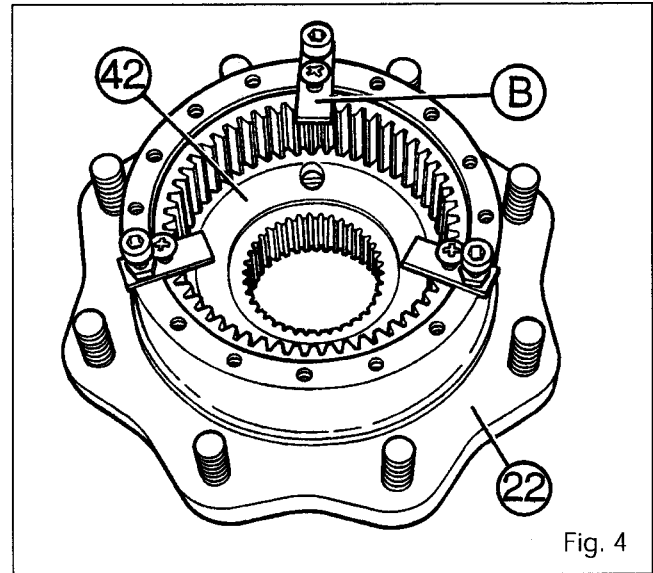

Fig. 4

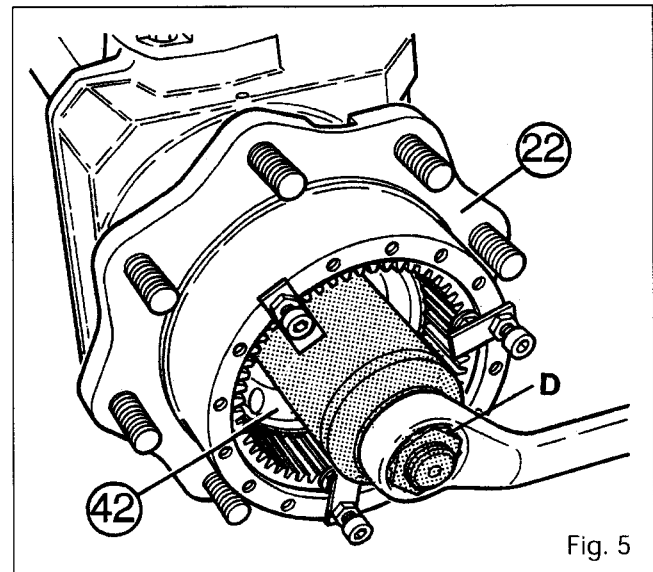

Fig. 5



## Front Axle - Final drive units

### E . Replacing a wheel stud

44. Chock the rear wheels and apply the handbrake.
45. Lift the relevant side with a trolley jack. Position a stand and remove the front wheel.
46. Drive out the faulty stud.
47. Lightly smear the new stud with Loctite 270 and fit it.
48. Lubricate the studs. Refit the wheel. Remove the stand and the trolley jack. Tighten the nuts to the same torques as specified in procedure 27.

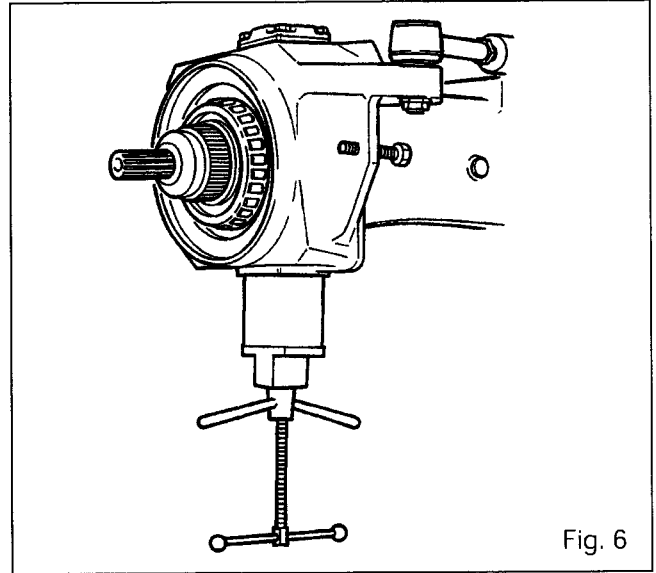

Fig. 6

### F . Disassembling the swivel housing

49. Remove the planetary carrier. Carry out procedures 1 to 6.
50. Remove the wheel hub. Carry out procedures 31 to 34.
51. If necessary, remove the seal **(45)** using a suitable extractor or a locally manufactured fixture. Remove the cotter pin and the nut from the steering ball joint. Extract the ball joint.
52. Fit a suitable sling on the swivel housing **(47)**.
53. Remove the bolts **(1)**, the cover **(15)** and the cup **(14)**. Extract the swivel pin **(11)** (Fig. 6) using tool MF451B and end fitting MF451B3 (See Part I).
54. Remove the bolts **(1)** and the cover **(2)**. Remove the shims **(3)** and the cup **(4)**. Extract the swivel pin **(7)** as already described for the lower pin (Fig. 6). If necessary, extract the cones **(5)** and **(13)** from the swivel pins.
55. Protect the splines on the universal drive shaft so that the seal **(16)** is not damaged.
56. Remove the swivel housing **(47)**.
57. if necessary, remove the seal **(16)** and drive out the bush **(17)**.  
**Note: Bush (31) is fitted with Loctite 270.**
58. If necessary, remove the universal drive shaft. Remove the seal **(8)** and bush **(9)**.



8B01.10

## 6100 SERIES TRACTORS

**Front Axle - Final drive units****G. Reassembling the swivel housing**

59. Clean and check the parts, and replace any that are faulty.
60. If they were removed, fit the bush (9) and seal (8) fully home on the shoulder of the axle housing (52). Lubricate the seal (8). Refit the universal drive shaft. Insert a guide through the oil filling port to align the left-hand drive shaft with the differential.
61. If they were removed, fit the bush (17) and seal (16) fully home on the shoulder of the swivel housing (47).
62. Replace the seal (12). The lip on the seal must be positioned as shown in Fig. 7. Fit the cone (13) fully home on the swivel pin (11).
63. The steering lock stops are adjusted (Fig. 8) by adjusting the bolts (48) See the data below, according to the required steering lock. After this adjustment, adjust the nut (49).

Dimension X	Steering lock
77 mm	35°
63 mm	40°
34 mm	50°

64. Refit the swivel housing (47). Place a seal on the swivel pin (7), coated with Anti-Seize grease. Position the swivel pin so that the swivel housing assembly is aligned with the axle housing (52). Fit the swivel pin.
65. Fit the cup (4), shims (3) and the cover (2). Fit the bolts (1) and tighten them evenly and alternately.
66. Fit the swivel pin (11), coated with Anti-Seize grease, checking that the lip on the seal (12) is correctly positioned. During this fitting operation, position the cup (14), the cover (15) and the grease nipple (32) (Fig. 7). Fit the bolts (1) and tighten them to a torque of 115 to 140 Nm in the same way as in procedure 65. **Check that the swivel pins (7) and (11) are properly in contact with the axle housing.**
67. After fitting the pins, remove the shims (3). Remove the cover (2) and tighten the bolts to a torque of 115 to 140 Nm.

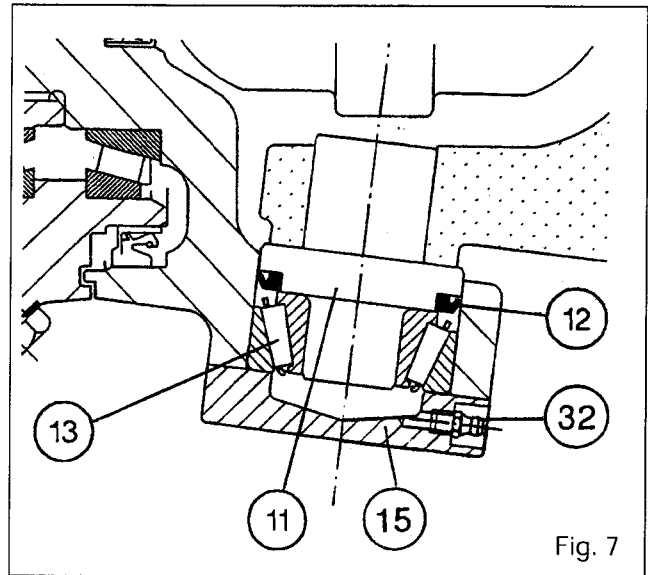

Fig. 7

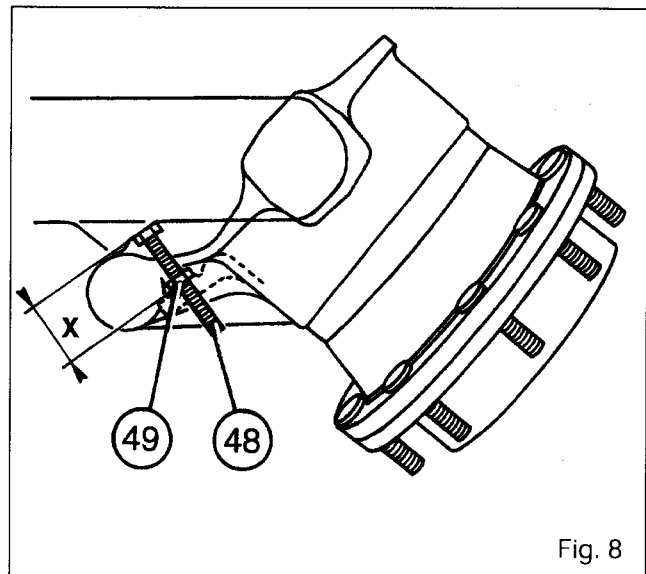

Fig. 8



## Front Axle - Final drive units

### Shimming P1 (Fig. 10)

68. Using a dial gauge, measure the end play, using a lever between the axle housing and the swivel housing (Fig. 9).

69. Make up the play measured during the previous operation with the necessary thickness of shims (3). To obtain P1, add additional shims with a thickness of between 0.15 and 0.25 mm (0.15/0.25 being the preload value).

70. Remove the bolts (1), the cover (2) fitted with the grease nipple (32), and the cup (4). Refit the cup and the shims (3) selected during procedure 69. Refit the cover. Tighten the bolts (1) to a torque of 115 to 140 Nm.

71. Using a grease pump, lubricate the bearing (13) (14) and (4) (5).

72. Smear the circumference of the seal (45) with Loctite 542 (Fig. 11) and oil the lips.

Fit the seal using the following tools:

- 3378039M1: axles AG 125 and AG 155,
  - 3378058M1: axles AG 85 and AG 105,
- and the following bushes:
- 3378040M1: axles AG 85 and AG 105,
  - 3378056M1: axles AG 125 and AG 155.

**Note : Tool A (Part I) must be fully tightened on the swivel housing. Coat nut D (see Part I) and the mating face with graphite grease. The seal (45) is not positioned fully home on the shoulder of the swivel housing. The fitting position is determined by the bush used.**

Positioning dimension for seal (45):

- Axles AG 85, AG 105, AG 125 and AG 155: 11.5 from face F (Fig. 11A).

Reinstall the steering balljoint. Tighten the nut to a torque of 115 to 130 Nm. Lock the nut with a new cotter pin.

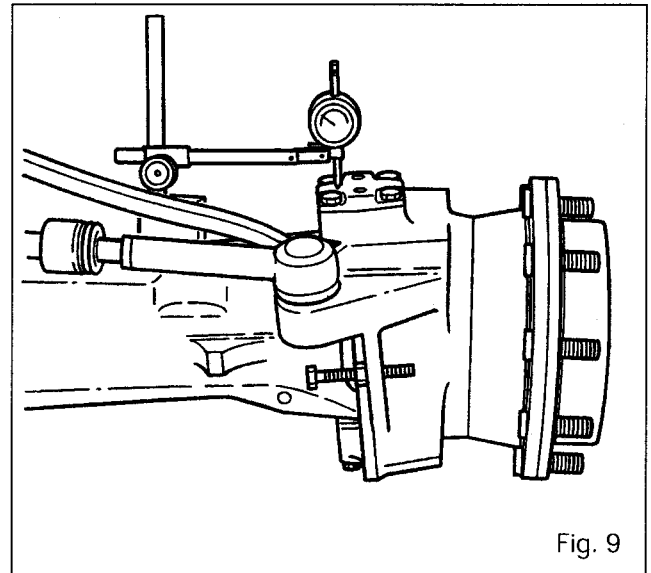

Fig. 9

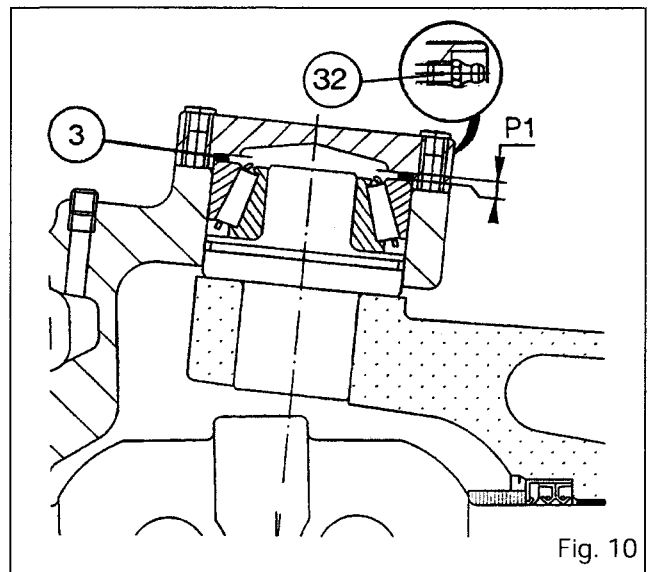

Fig. 10

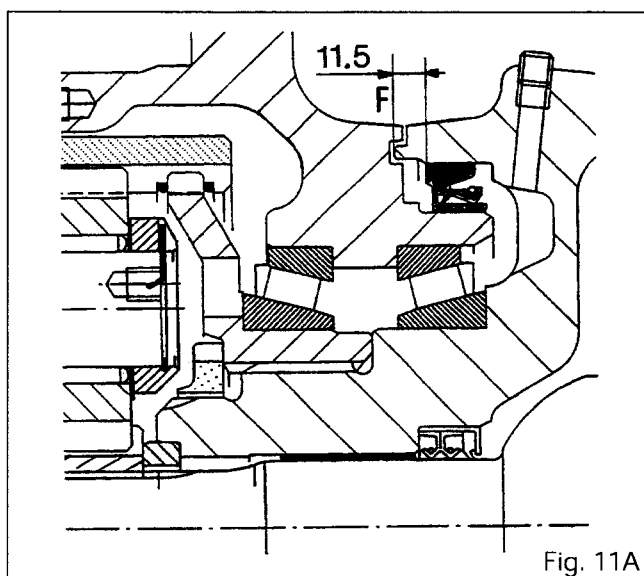

Fig. 11A

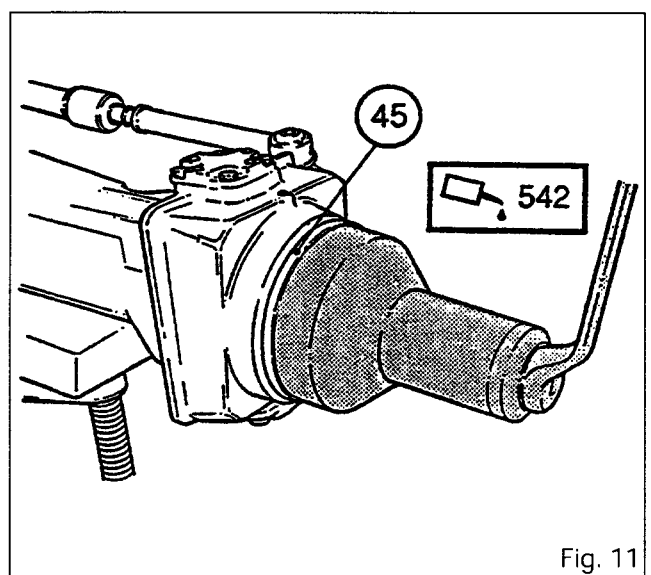

Fig. 11



8B01.12

## 6100 SERIES TRACTORS

**Front Axle - Final drive units**

73. Refit the wheel hub. Carry out procedures 36 to 41.
74. Remove the protection from the splines on the universal drive shaft. Fit the sun gear **(28)** and the circlip **(29)**.
75. Refit the planetary carrier. Carry out procedures 23 to 29.

## H. Removing and refitting the universal drive shaft

### Removal

76. Remove the planetary carrier. Carry out procedures 1 to 6.
77. Remove the circlip **(29)** and the sun gear **(28)**, and extract the steering ball joint.
78. To remove the swivel housing assembly **(47)** and the wheel hub **(22)**, use the method of extracting the swivel pins **(7)** and **(11)** described in Part F.
79. Remove the universal drive shaft **(10)**.

### Disassembling the universal joint (Fig. 12)

80. Hold the outer section **(1)** of the drive shaft in a vice fitted with soft jaws.
81. Remove the four circlips **(3)** from each end of the universal joint.
82. Using a plastic mallet, drive the centre yoke **(2)** downwards until the bearing sleeve protrudes.
83. Tighten the bearing sleeve in a vice and strike the yoke to drive it out.
84. Remove the opposite bearing sleeve in the same manner, and remove the outer section of the shaft.
85. Turn the shaft assembly through 90°, then repeat procedures 82 to 84 to free the universal joint from the shaft.
86. Clamp the lower section of the drive shaft in the vice and repeat procedures 81 to 85.

### Reassembling the universal joint

87. Clean and check the parts. Replace the universal joint assembly, including the cross-pins, the seals, the bearings, the sleeves and the circlips.
88. Coat the needles with bearing grease and check that they are all positioned in the sleeves.

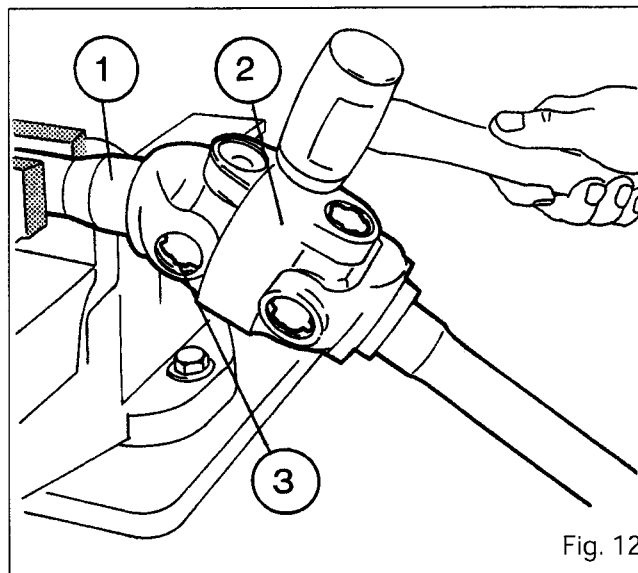

Fig. 12



## Front Axle - Final drive units

89. Position the universal joint cross-pin **(1)** in the yoke and push it as far as possible to the side (Fig. 13) so that the end of the cross-pin serves as a guide for the fitting of the sleeve with the needles.
90. Drive the sleeve **(1)** sufficiently far into the yoke, holding the cross-pin (Fig. 14) to fit the circlip.
91. Fit the other sleeves and cross-pins in the same manner.

### Refitting

92. Refit the universal drive shaft. Insert a guide through the filling port in order to align the left-hand drive shaft with the differential.
93. Refit the assembly comprising the swivel housing and the wheel hub. Fit a seal **(6)** on the swivel pin **(7)**, coated with Anti-Seize grease. Position the pin so that the swivel housing assembly is aligned with the axle housing **(52)**. Fit the pin.
94. Fit the cup **(4)**, the shims **(3)** and the cover **(2)** fitted with the grease nipple **(32)**. Fit the bolts **(1)** and tighten them evenly and alternately to a torque of between 115 and 140 Nm.
95. Replace the seal **(12)**. Fit the lip of the seal in the direction shown in Fig. 7. Fit the cone **(13)** fully home on the swivel pin **(11)**.
96. Fit the swivel pin **(11)** coated with Anti-Seize grease, checking that the lip of seal **(12)** is correctly positioned during fitting. Position the cup **(14)** and cover **(15)**. Fit the bolts **(1)** and tighten them to a torque of 115 to 140 Nm in the same way as described in procedure 94. **Check that the swivel pin (7) and (11) are properly in contact with the axle housing (52).**
97. Use a grease pump to lubricate the bearing **(13)** **(14)** and **(4)** **(5)**.
98. Refit the steering ball joint. Tighten the nut to a torque of 115 to 130 Nm. Lock the nut with a new cotter pin.
99. Remove the protection from the shaft. Refit the sun gear **(28)** and the circlip **(29)**.
100. Refit the planetary carrier. Carry out procedures 23 to 29.

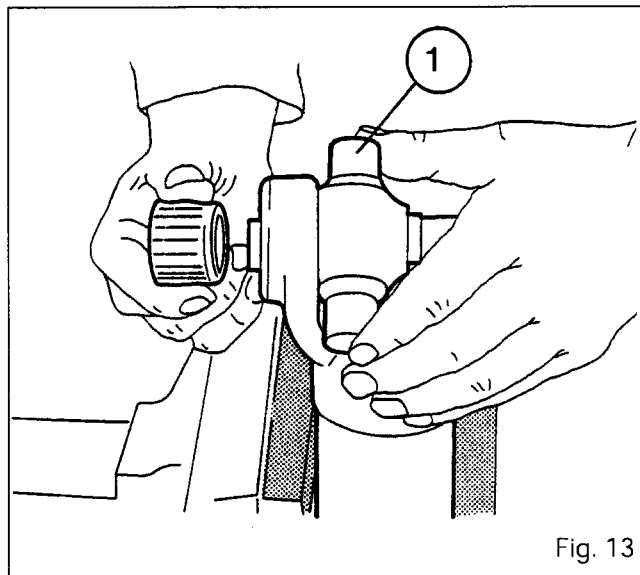

Fig. 13

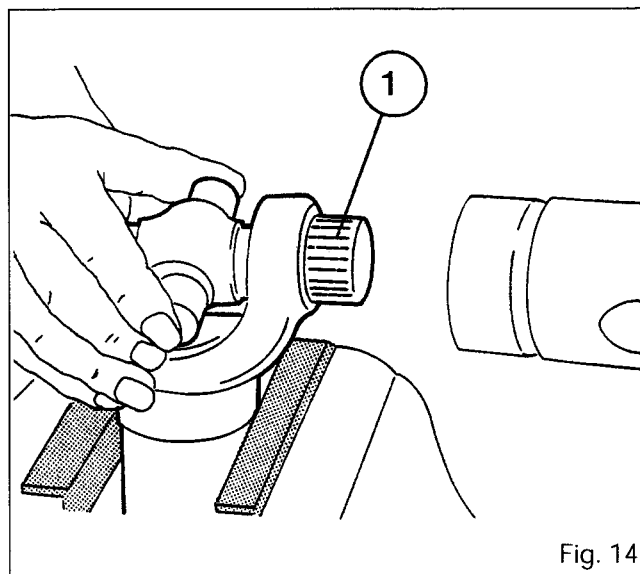

Fig. 14





8B01.14

# 6100 SERIES TRACTORS



## Front Axle - Final drive units

### I. Service tools

Tools available through the MF network

**MF451B - Swivel extractor (Fig. 15)**

**MF451B/3 - End fitting for extractor M18 (Fig. 15)**

**3376880M1 - Socket for ring gear carrier nuts (axles AG 85 and AG 105) (Fig. 16)**

**3378028M1 - Socket for ring gear carrier nuts (axles AG 125 and AG 155) (Fig. 17)**

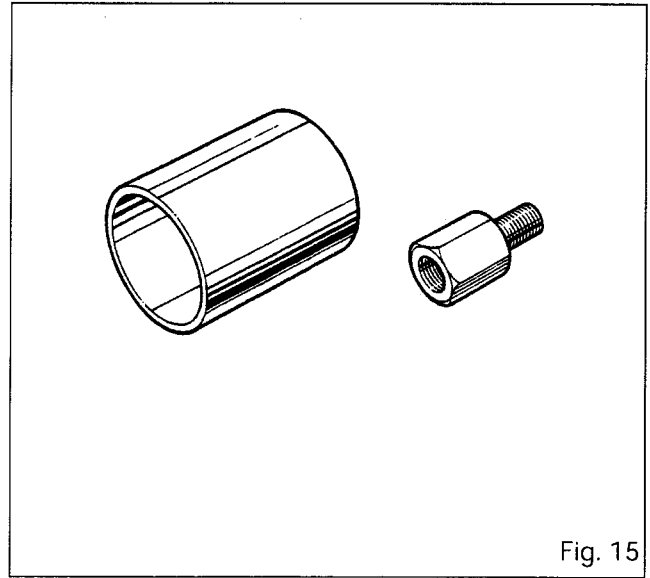

Fig. 15

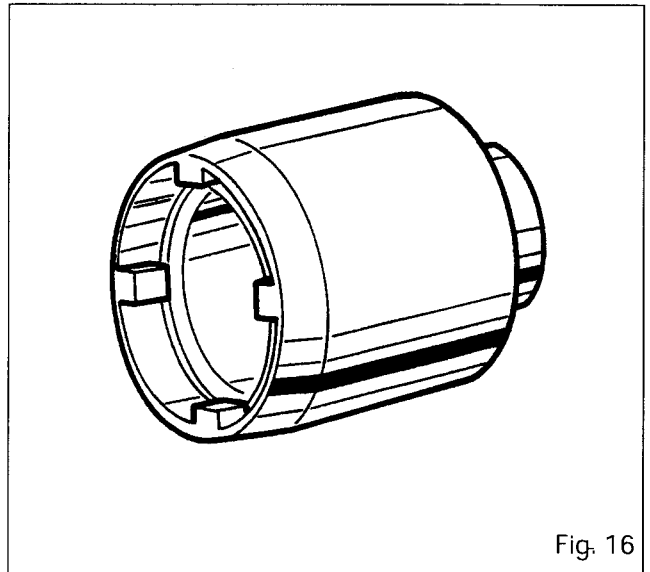

Fig. 16

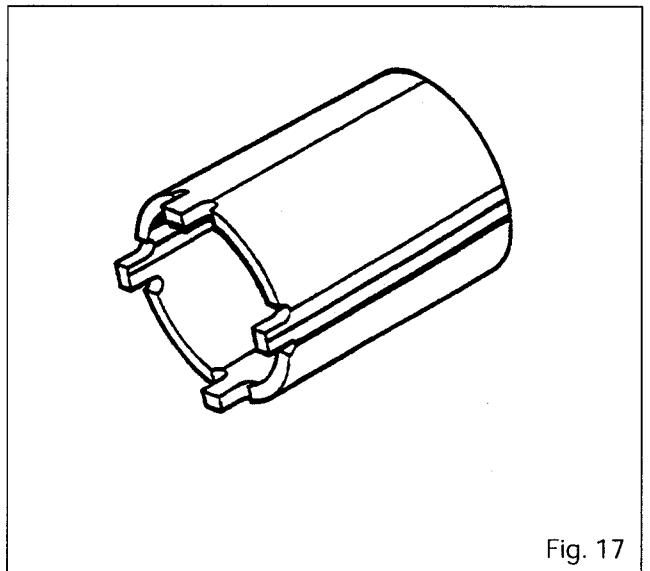

Fig. 17



## Front Axle - Final drive units

**3378038M1 - Extractor for ring gear carrier (42)  
(Fig. 18)**

**3378039M1 - Fitting tool for ring gear carrier and  
seals (axles AG 125 and AG 155) (Fig. 19)**

**\* 3378040M1 - Fitting tool for seal (45) (axles AG  
85 and AG 105) (Fig. 20)**

**\* 3378056M1 - Fitting tool for seal (45) (axles AG  
125 and AG 155) (Fig. 20)**

**3378058M1 - Fitting tool for ring gear carrier and  
seals (axles AG 85 and AG 105) (Fig. 19)**

**\* Bush 3378040M1 must be used with basic tool  
3378058M1.**

**\* Bush 3378056M1 must be used with basic tool  
3378039M1.**

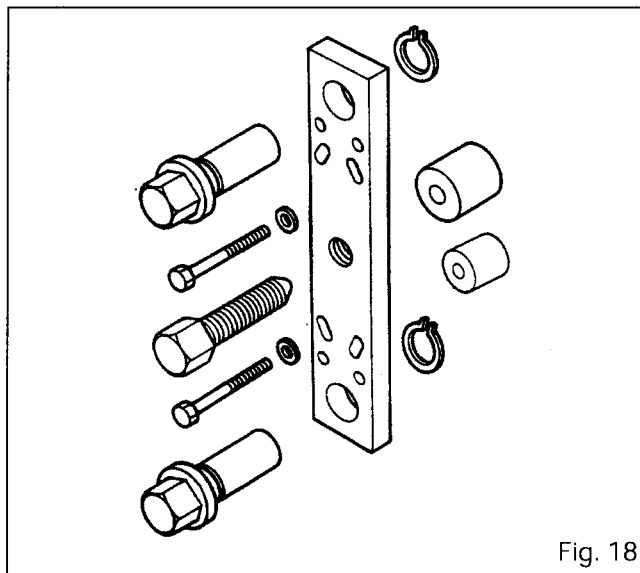

Fig. 18

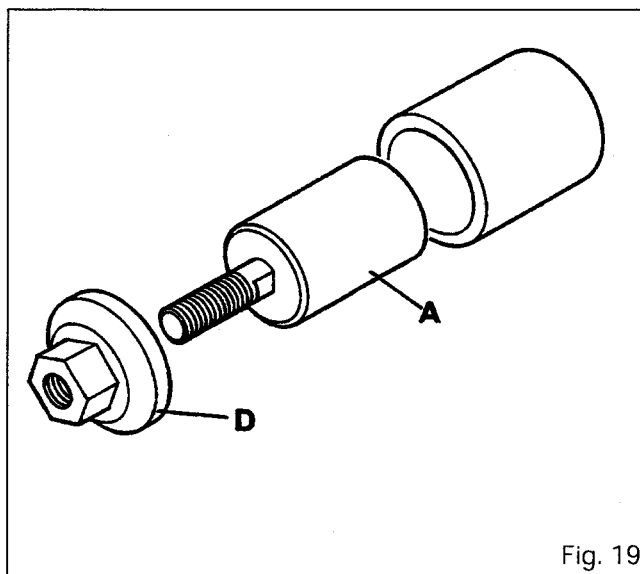

Fig. 19

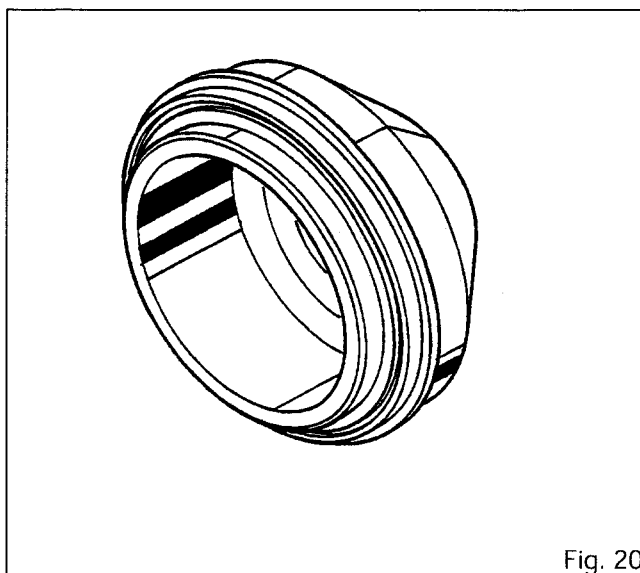

Fig. 20





## **Front axle - Differential**

### 8 C01 Differential

#### CONTENTS

-	<b>General</b> _____	2
A.	<b>Splitting the front axle from the frame</b> _____	6
B.	<b>Removing the swivel housings, wheel hubs and drive shafts</b>	6
C.	<b>Removing the differential housing assembly</b> _____	6
D.	<b>Disassembling the differential</b> _____	7
E.	<b>Removing the differential lock</b> _____	8
F.	<b>Removing the drive pinion</b> _____	8
G.	<b>Reassembling the drive pinion</b> _____	9
H.	<b>Reassembling the differential lock</b> _____	12
I.	<b>Piston leak test</b> _____	13
J.	<b>Refitting the differential housing assembly</b> _____	14
K.	<b>Refitting the swivel housing, wheel hubs and drive shafts</b> _____	14
L.	<b>Recoupling the front axle and frame</b> _____	14
M.	<b>Service tools</b> _____	15



8C01.2

## 6100 SERIES TRACTORS



### Front axle - Differential

**Note: Tractors in series 6100 are equipped with four different categories of front axle:**

**AG 85 - Tractors 6100 to 6140**

**AG 105 - Tractors 6150 to 6160**

**AG 125 - Tractors 6170 to 6180**

**AG 155 - Tractors 6190**

**A plate riveted on the right-hand side of the axle housing indicates the category and serial number.**

**The reference of axle AG 155 for the 6190 is different from the reference of axle AG 155 fitted on 8100 series tractors.**

The clearance between the crownwheel and drive pinion is adjusted with shims **(22)** positioned behind the cup **(29)**.

Preloading on the housing and crownwheel assembly is obtained by means of a splined nut **(32)**.

**Specific features (6190 tractors)**

The end of the drive pinion is fitted with 24 splines in the same way as AG 155 type axles fitted on tractors in series 8100.

### General

The bevel crownwheel and pinion assembly containing the differential lock device (Hydralock) is mounted in a housing **(7)** comprising two half bearings **(43)** secured by bolts **(42)**.

The drive pinion is mounted at the rear of the housing on two taper roller bearings which are installed in opposition. Its position can be adjusted by means of shims **(8)** located behind the head roller bearing. The roller bearings are adjusted by means of shims **(2)** positioned between the spacer **(45)** and the bearing cone **(5)**.

The assembly is sealed by means of a lip **(4)** and an O-ring **(40)** installed on the drive pinion. Axles AG 85, AG 105 and AG 125 have two planetary pinions **(38)** and one pin **(36)**.

Axle AG 155 has four planetary pinions **(38)** and one two pins **(36)**.

### Service tools (see Section M)

MF451B - Swivel extractor

MF451B3 - End fitting for extractor M18

MF471 - Differential locking spring compression tool

3376881M1 - Clamping tool for drive pinion nut (Axles AG 105 - AG 125)

3376927M1 - Clamping tool for drive pinion nut (Axles AG 85)

3378051M1 - Clamping tool for drive pinion nut (Axles AG 155)

### List of parts

- |                             |                                  |
|-----------------------------|----------------------------------|
| <b>(1)</b> Nut              | <b>(23)</b> Bolt                 |
| <b>(2)</b> Shim(s)          | <b>(24)</b> Cover                |
| <b>(3)</b> Spacer           | <b>(25)</b> Half housing         |
| <b>(4)</b> Seal             | <b>(26)</b> Half housing         |
| <b>(5)</b> Bearing cone     | <b>(27)</b> Crownwheel           |
| <b>(6)</b> Bearing cup      | <b>(28)</b> Nut                  |
| <b>(7)</b> Housing          | <b>(29)</b> Bearing cup          |
| <b>(8)</b> Shim(s)          | <b>(30)</b> Bolt                 |
| <b>(9)</b> Bearing cup      | <b>(31)</b> Locking plate        |
| <b>(10)</b> Bearing cone    | <b>(32)</b> Splined nut          |
| <b>(11)</b> Sun gear        | <b>(33)</b> Bearing cone         |
| <b>(12)</b> Tab washer      | <b>(34)</b> Locating dowel       |
| <b>(13)</b> Retaining ring  | <b>(35)</b> Washer               |
| <b>(14)</b> Piston          | <b>(36)</b> Planetary pinion pin |
| <b>(15)</b> O-ring          | <b>(37)</b> Spherical washer     |
| <b>(16)</b> Friction washer | <b>(38)</b> Planetary pinion     |
| <b>(17)</b> Feder           | <b>(39)</b> Drive pinion         |
| <b>(18)</b> Spring          | <b>(40)</b> O-ring               |
| <b>(19)</b> O-ring          | <b>(42)</b> Bearing bolt         |
| <b>(20)</b> Guide washer    | <b>(43)</b> Half bearing         |
| <b>(21)</b> Washer          | <b>(44)</b> Centring bush        |
| <b>(22)</b> Shim(s)         | <b>(45)</b> Spacer               |
|                             | <b>(46)</b> Deflector            |



# 6100 SERIES TRACTORS



8C01.3

## Front axle - Differential

Overall view

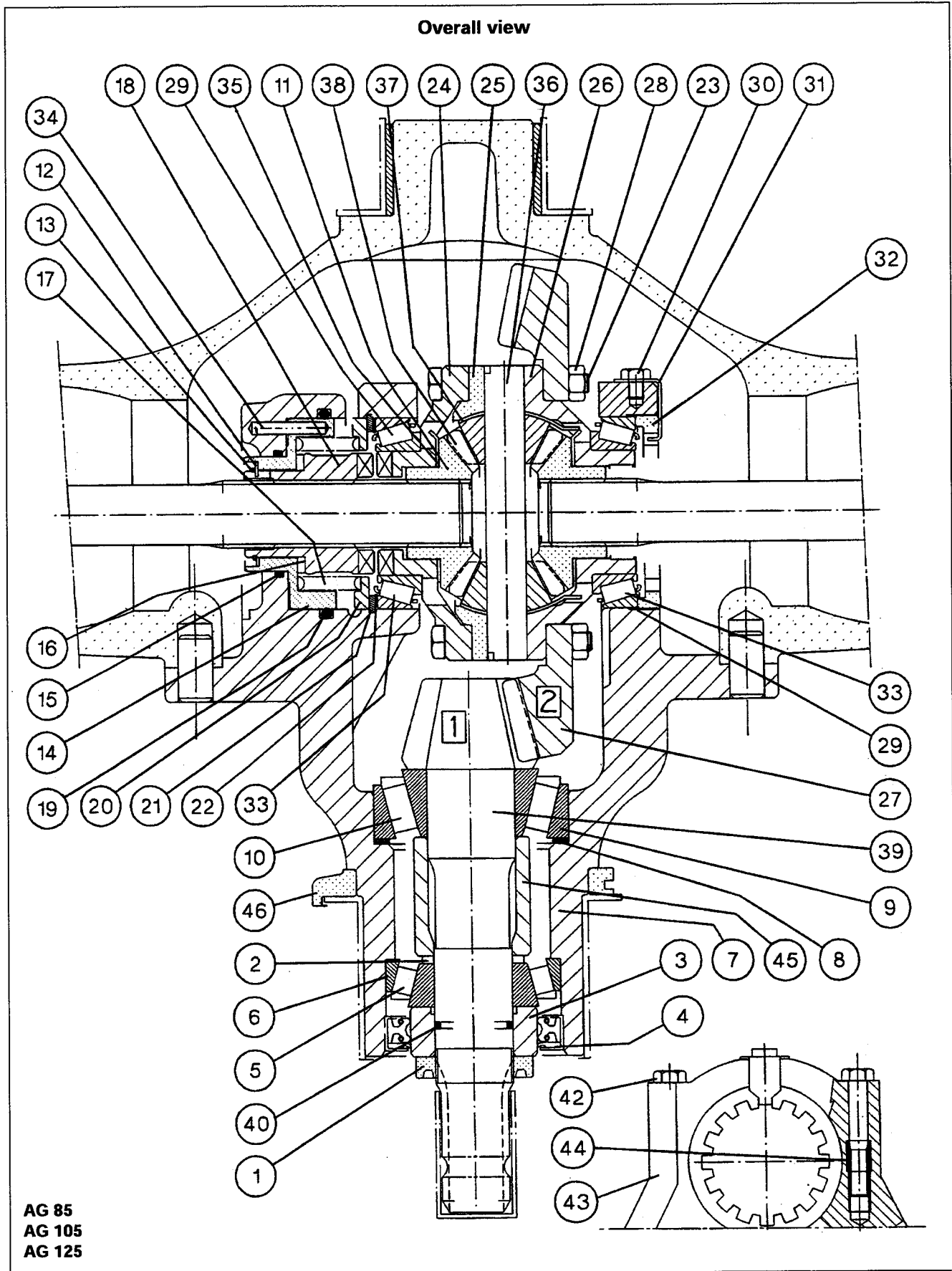

AG 85  
AG 105  
AG 125



6100 SERIES TRACTORS



8C01.4

Front axle - Differential

Overall view

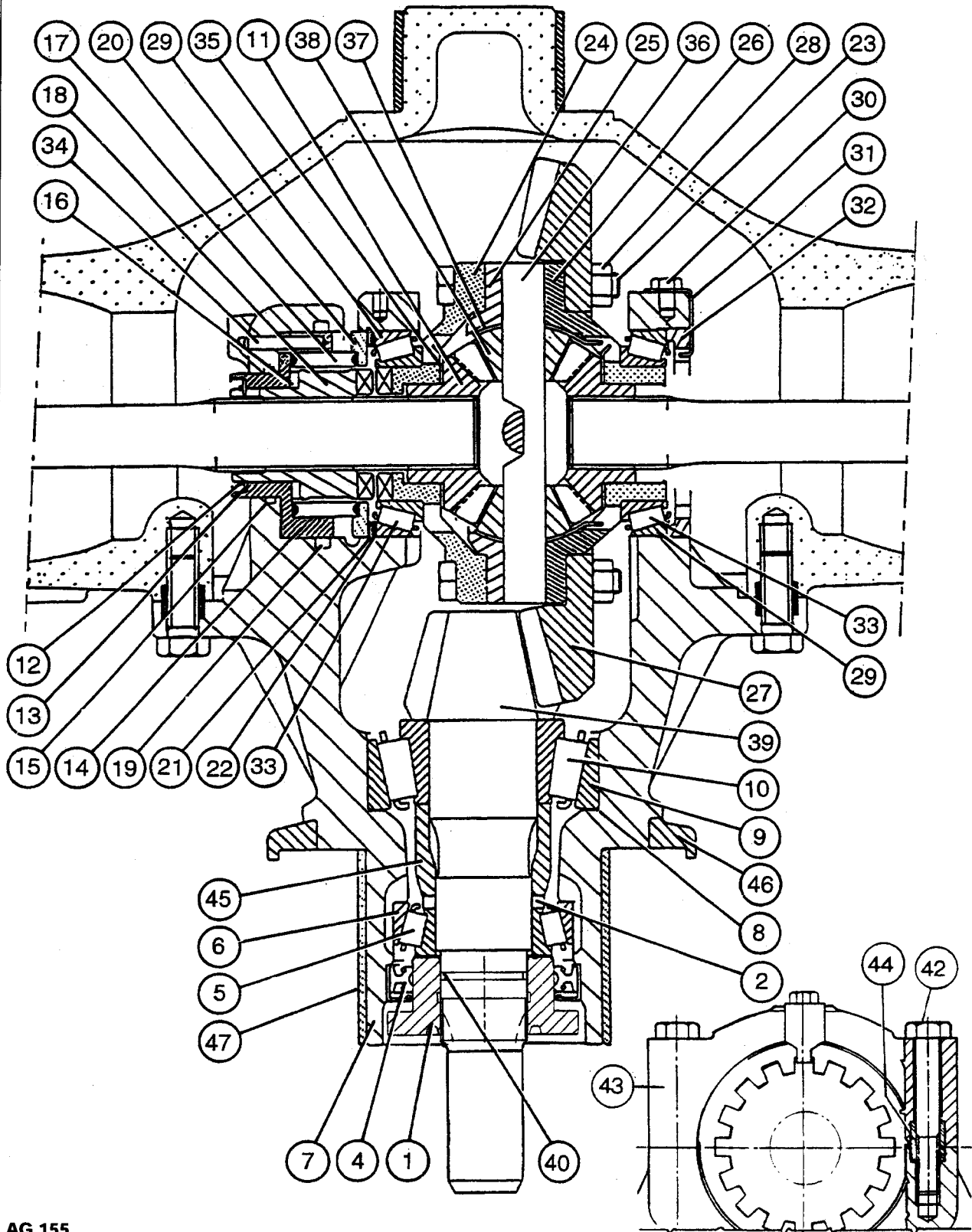

AG 155



6100 SERIES TRACTORS



8C01.5

Front axle - Differential

Exploded view

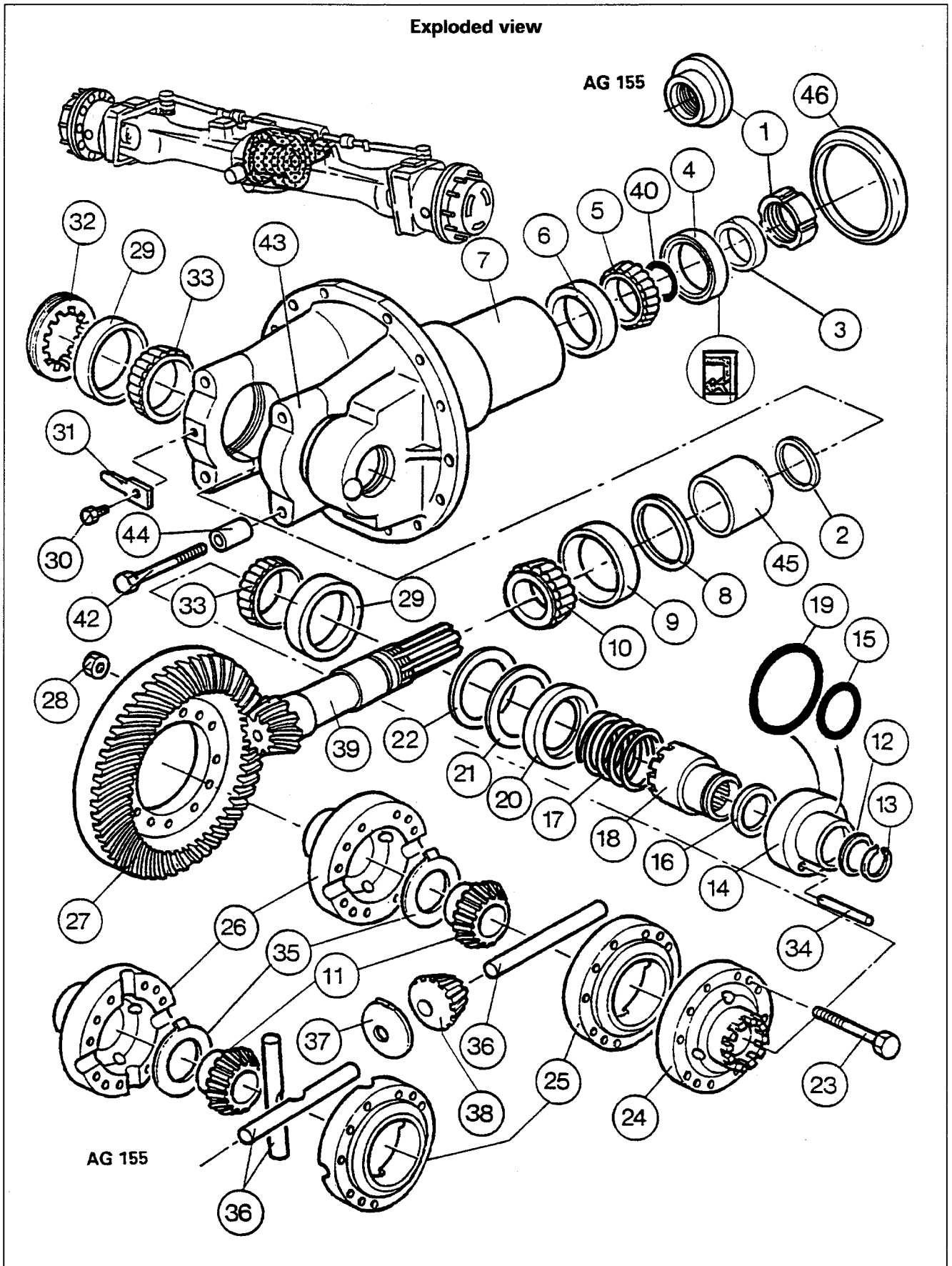





8C01.6

## 6100 SERIES TRACTORS

**Front axle - Differential****A. Splitting front axle from frame**

1. Drain the oil from the axle housing
2. Disconnect the axle and its bearings from the front frame (see Section 8F01).

**B. Removing swivel housings, wheel hubs and drive shafts**

**Note: Care must be taken when carrying out this operation.**

3. Remove the steering ball joints.
4. Support the swivel housing assembly in a suitable sling.

**Removing swivel housings (Figures 1 and 2)**

5. Remove bolts (1), the cover (15) and cup (14). Extract the swivel pin (11) (Fig. 2) using extractor MF451B and end fitting MF451B3 (see Part M).
6. Remove bolts (1), the cover (2), shims (3) and cup (4). Extract swivel pin (7) as described above for the lower pin (Fig. 2).
7. With the help of another person, remove the assemblies.
8. If necessary, remove the seals (8) and O-rings (40) (Fig. 1).

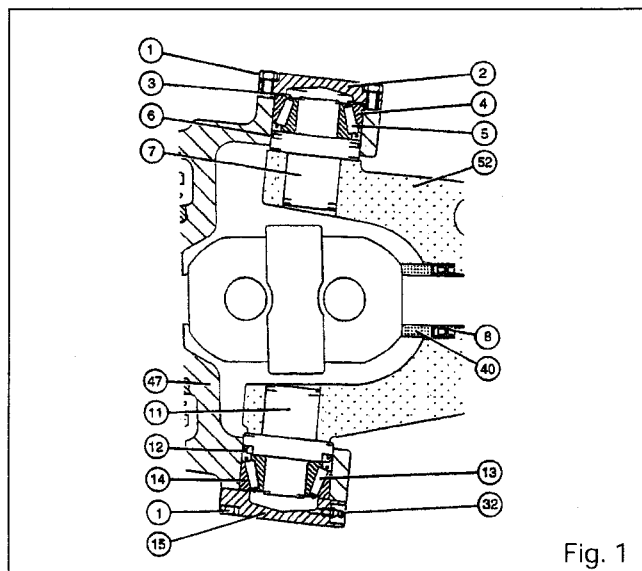

Fig. 1

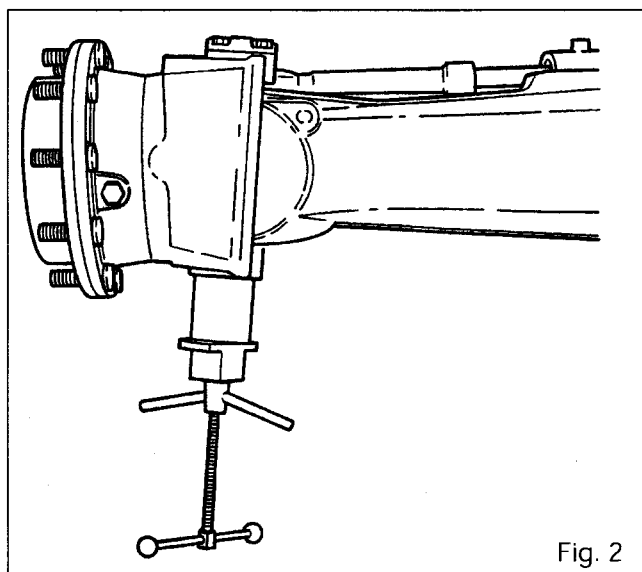

Fig. 2

**C. Removing the differential housing assembly**

9. Remove the attaching bolts from the steering ram and remove it.
10. Remove the bolts (1). Detach and remove the differential housing assembly (7) (Fig. 3). If necessary, remove the deflector (46).

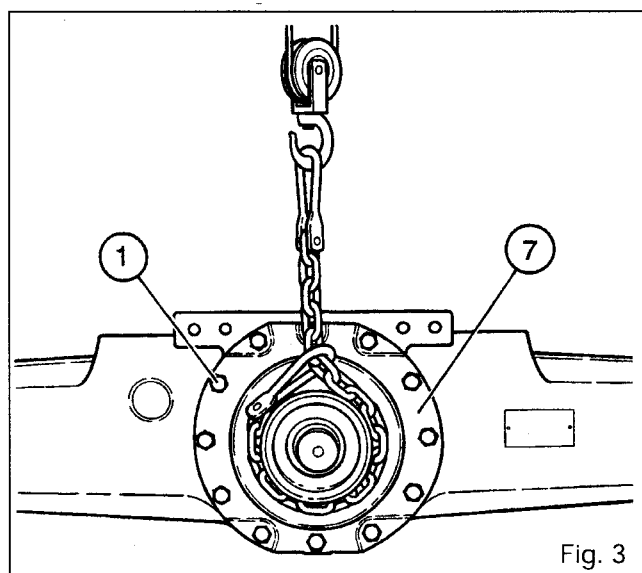

Fig. 3



## Front axle - Differential

### D. Disassembling the differential

11. Place the housing (7) in a soft-jawed vice (Fig. 4).
12. Remove the bolt (30) and its retainer (31) (Fig. 4).
13. Remove the splined nut (32) using the special locally-manufactured wrench (see Section M).
14. Remove the four bolts (42), and remove the half bearings (43) (Fig. 4).

**Note: Carefully remove the half bearing on the lock control side, with spring (17) compressed; the washer (21) must remain in the housing (7).**

15. Remove the complete differential assembly with the bearing cones (33) and cups (29) (Fig. 5). Separate the cups from the cones. Remove the shim or shims (22).

**Note: Keep the bearing cones and cups in pairs if they are to be reused.**

16. If necessary, extract the two bearing cones (33).
17. Place the differential assembly in a soft-jawed vice. Remove the nuts (28). Take out the bolts (23).  
**Note: Before disassembling, mark the position of the half housings (25) and (26) and of the cover (24) so they can be correctly paired when refitting.**
18. Separate the half housings (25), (26) and the cover (24).
19. Remove the sun gear (11) and washer (35).
20. Separate the pin or pins (36), the planetary pinions (38) and the spherical washers (37):
  - Fig. 6A: AG 155,
  - Fig. 6B: AG 85 - AG 105 - AG 125.

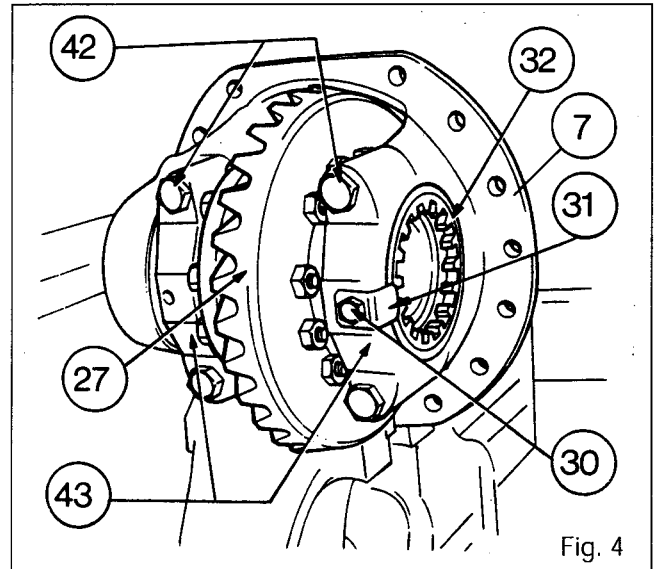

Fig. 4

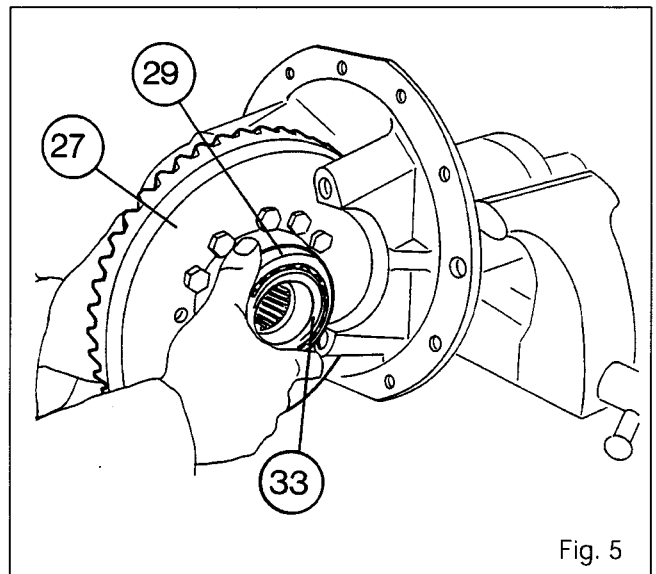

Fig. 5

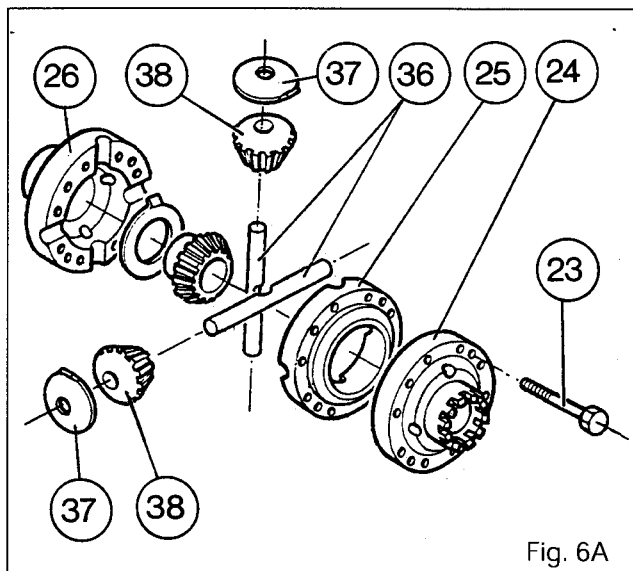

Fig. 6A

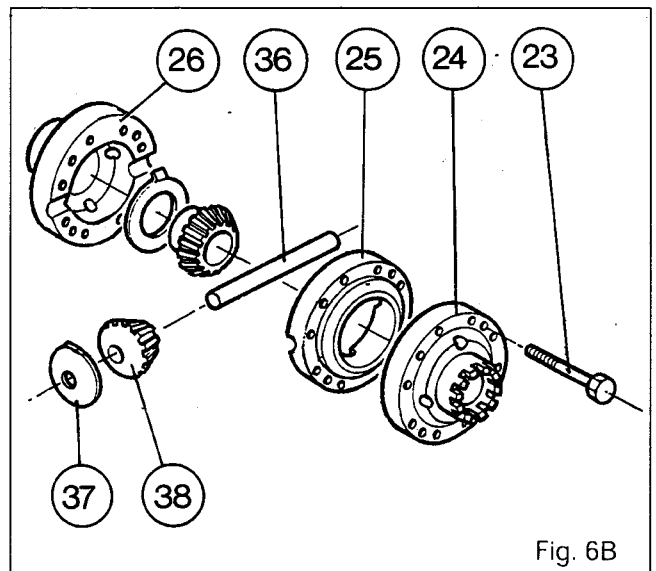

Fig. 6B



8C01.8

## 6100 SERIES TRACTORS

**Front axle - Differential****E. Removing the differential lock (Fig. 7)**

21. Using tool MF471 (see Part M) correctly centred, compress the spring (17) until the supporting washer (21) is freed.
22. Remove the washer (21).
23. Gradually release the spring (17).
24. Remove the tool.
25. Remove the guide washer (20) from the spring.
26. Remove the spring (17).
27. Disassemble the retaining ring (13) from the dog tooth coupler (18).
28. Remove the coupler (18), the friction washer (16) and the tab washer (12).
29. Remove the piston (14).
30. Remove the O-rings (15) and (19).

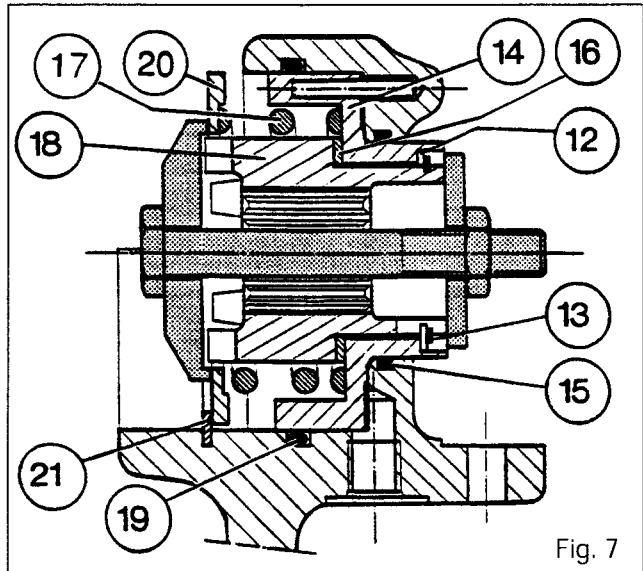

Fig. 7

**F. Removing the drive pinion**

31. Unlock (according to fitting) and lock the nut (1) with the following type of wrench (Figures 8 and 9):
  - 3376927M1 (axles AG 85),
  - 3376881M1 (axles AG 105 - AG 125),
  - 3378051M1 (axles AG 155).
 Unscrew the drive pinion in the clockwise direction (Fig. 9) using the special locally-manufactured sleeve "C" (Fig. 8) (See Part M).
32. Remove the drive pinion assembly, the bearing cone (10), the spacer (45), the shims (2) and the O-ring (40) from the housing.
33. Separate the drive pinion, the O-ring (40), the shims (2) and the spacer (45).
34. Extract the bearing cone (10) from the drive pinion.
35. Remove the cup (9) and shims (8).
36. Remove the spacer (3). Extract the seal (4). Remove the cone (5). Drive out the cup (6).

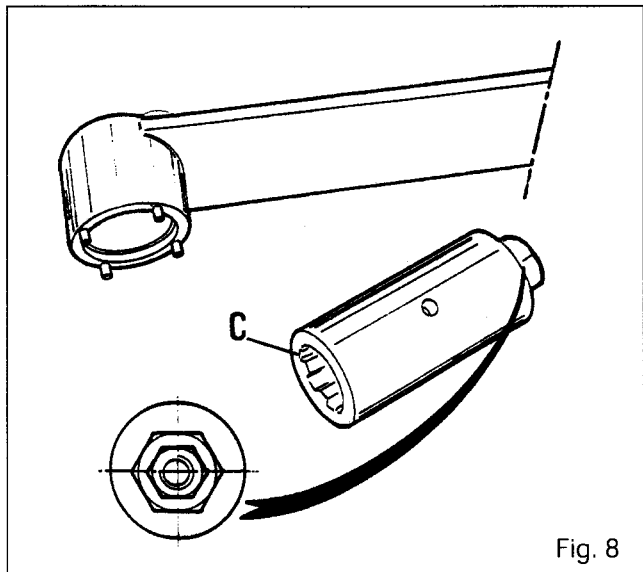

Fig. 8

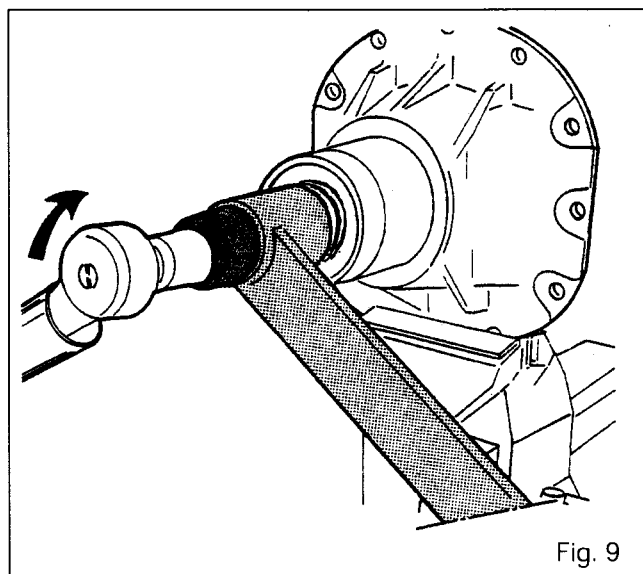

Fig. 9



## Front axle - Differential

### G. Reassembling the drive pinion

37. Before reassembling, clean the parts and replace any which are faulty. Check that the differential lock channel is not obstructed.

**Note:** If it should prove necessary to replace the crownwheel (27) or the drive pinion (39), these two parts should both be replaced together. The parts are paired as indicated by a number marked on the front face of the drive pinion and on the crownwheel.

38. Adjust the position of the drive pinion (Fig. 10). The thickness of the shims required to position the drive pinion correctly is calculated using the following formula:

$$SP = C - E - (d \pm r).$$

- SP:** Required thickness of shims (8)  
**C:** Distance measured between the bearing face of the cup (9) on the housing (7) and the machined face F.  
**d:** Nominal dimension for positioning of the drive pinion.  
 . AG 85 - AG 105 - AG 125 = 118 mm  $\pm$  0.10  
 . AG 155 = 133.5 mm  $\pm$  0.10  
**E:** Thickness of bearing (9), (10)  
**r:** Actual dimension marked on the drive pinion (Fig. 11). This may be a positive or negative value (to be added to or subtracted from the nominal dimension d).

### Operating procedure

39. Measure dimensions C and E with a depth gauge.

**Note:** Make sure that the bearing cone (10) is correctly seated in the cup (9).

40. After measuring the dimensions, apply the formula to determine the required shim thickness.  
 41. Fit the cone fully home against the shoulder on the drive pinion, using a press and a suitable fixture (Fig. 12).  
 42. Place the shims (8), ensuring the previously calculated thickness, in the housing.  
 43. Fit the cup (9).  
 44. Shim the bearings (9), (10) and (5), (6).

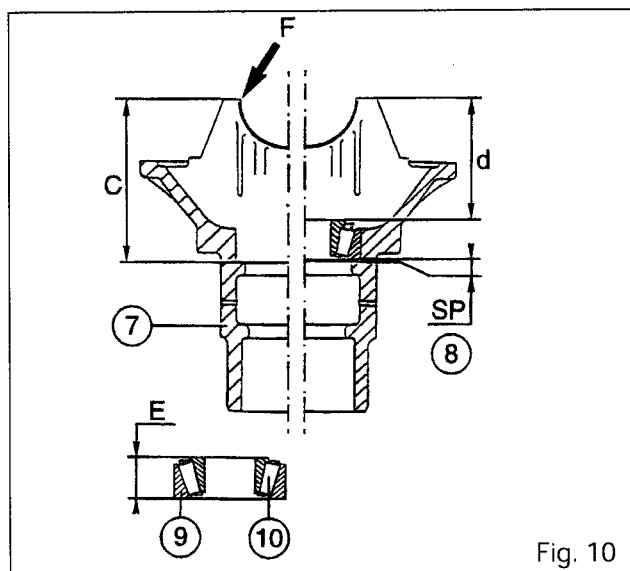

Fig. 10

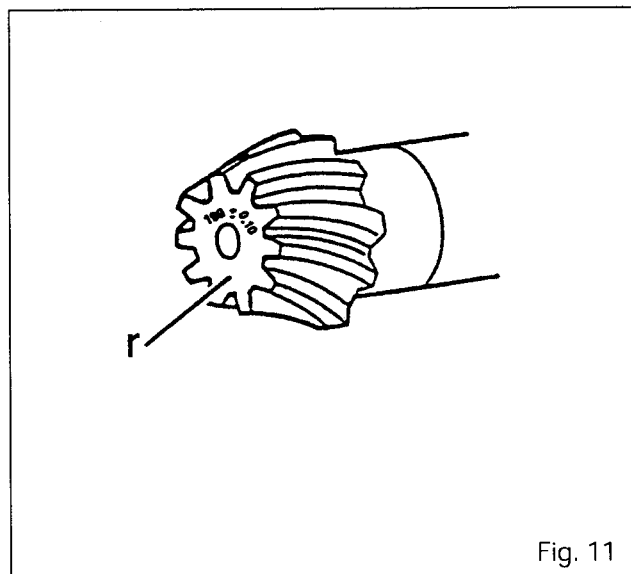

Fig. 11

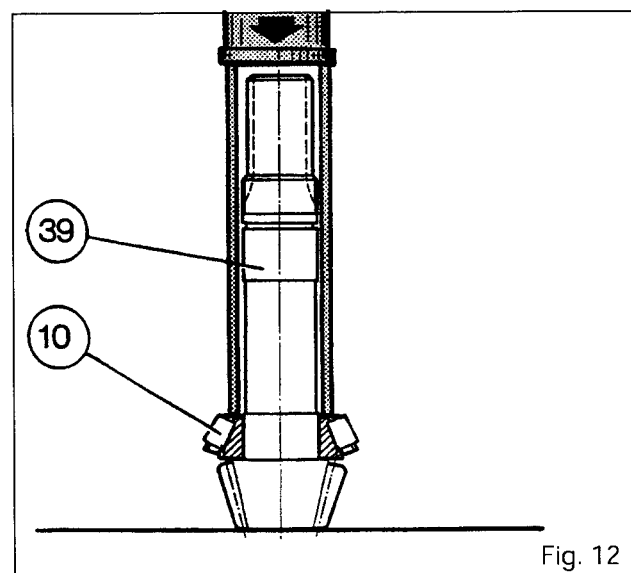

Fig. 12



8C01.10

## 6100 SERIES TRACTORS

**Front axle - Differential****Method**

45. Place the prepared drive pinion in the housing (7) as shown in Figure 13A or 13B. Rotate the housing through several turns in order to correctly seat the bearing cone (10) in the cup (9). Slide the spacer (45) into position with its chamfered edge towards the splines on the drive pinion.
46. Using a depth gauge, measure dimension 'F' according to the formula:  $A - B$  (Fig. 13A or 13B).
47. Press on the cup (6) while turning it alternately to the right and to the left in order to seat it correctly on bearing cone (5). Measure dimension «G» (Fig. 13A or 13B).
48. Determine the thickness **SP1** of shims (2) according to the following formula:  
**G - F**: Axles AG 85 - AG 105 - AG 125 (Fig. 13A),  
**(G + F) - 0.05** (0.05 being the preload value): Axles AG 155 (Fig. 13B).

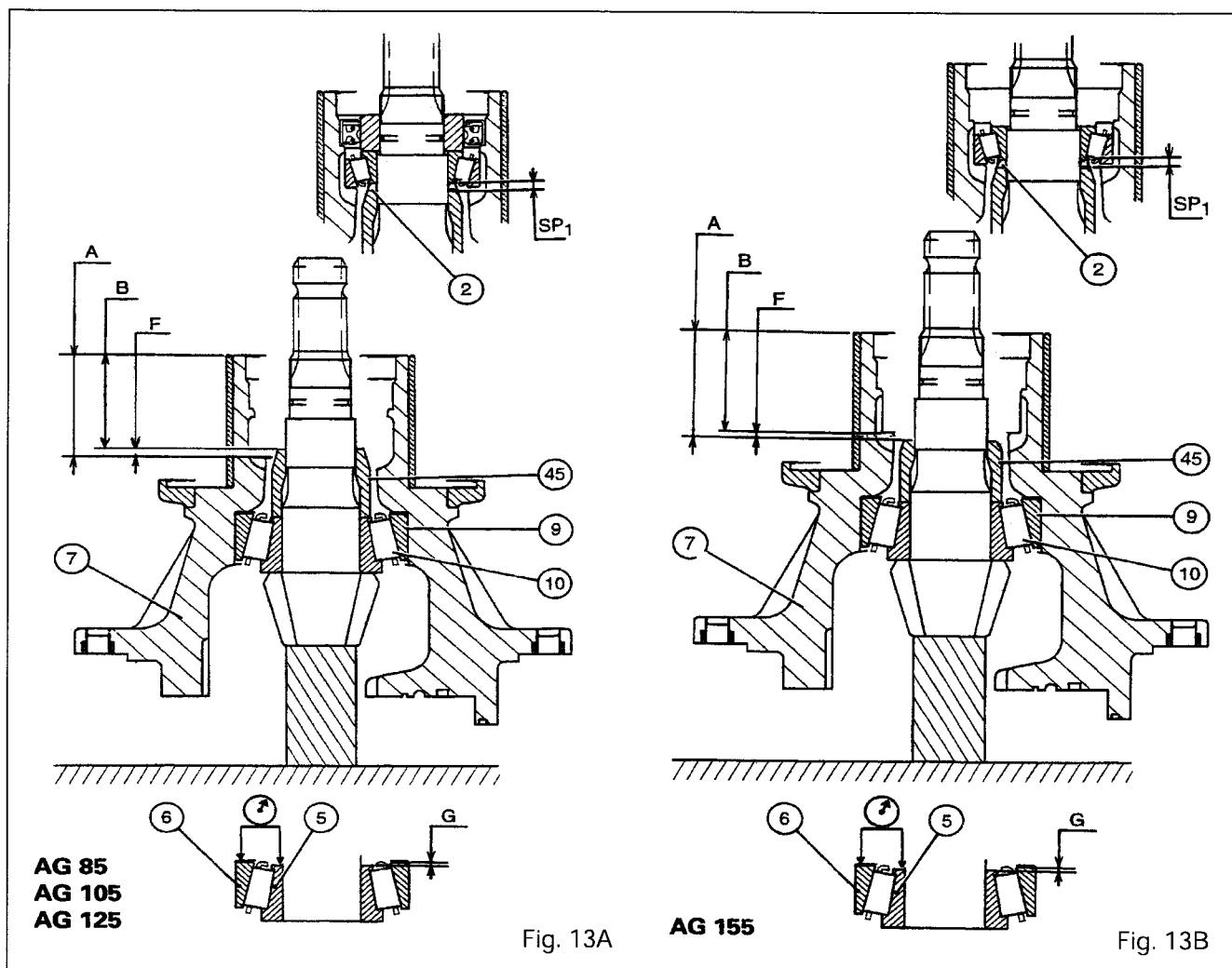



## Front axle - Differential

49. Position the cup **(6)** fully home in the housing.
50. Slide the shim **(2)** defined in procedure 48 on the drive pinion. Fit the bearing cone **(5)** and the lubricated O-ring **(40)** (Fig. 14).
51. Grease the lips of seal **(4)** and use a locally manufactured drift to fit it fully home against the shoulder (Part M). Fit the spacer **(3)** (according to category) (Fig. 14).
52. Fit the nut **(1)** and fully tighten with wrench 3376881M1, 3376927M1 or 3378051M1 (according to category). Using a special sleeve and a torque wrench, turn the drive pinion until the following torque is obtained (Fig. 15):
  - AG 85 - AG 105 - AG 125: 360 to 400 Nm,
  - AG 155: 450 to 500 Nm.
53. Check the torque on the drive pinion.

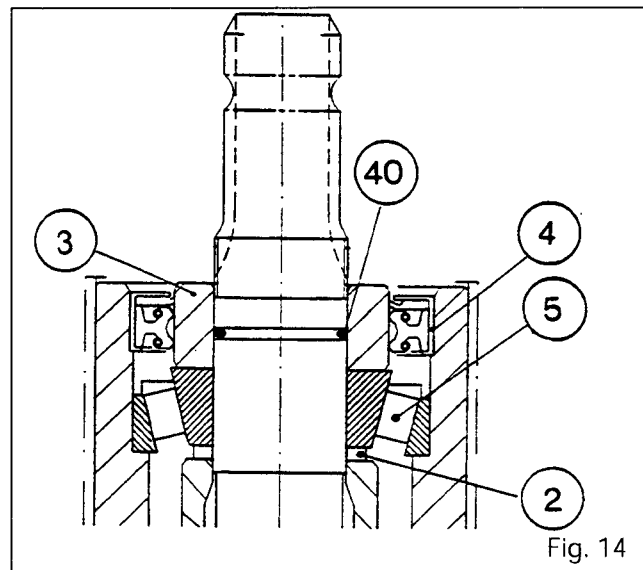

### Method

54. Rotate the drive pinion through several turns using a dial type torque wrench and the special sleeve (Fig. 16). Then, check that the torque is between 2 and 4 Nm.
55. After checking the torque, remove the nut **(1)** and coat it with Loctite 270. Tighten the nut as described in procedure 52.

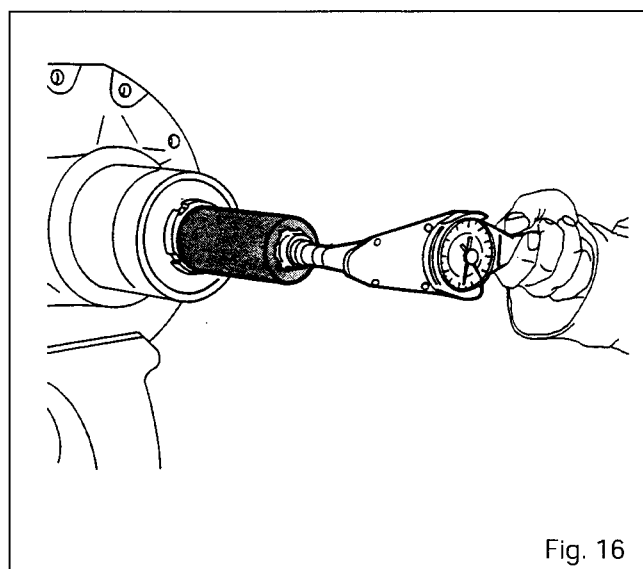
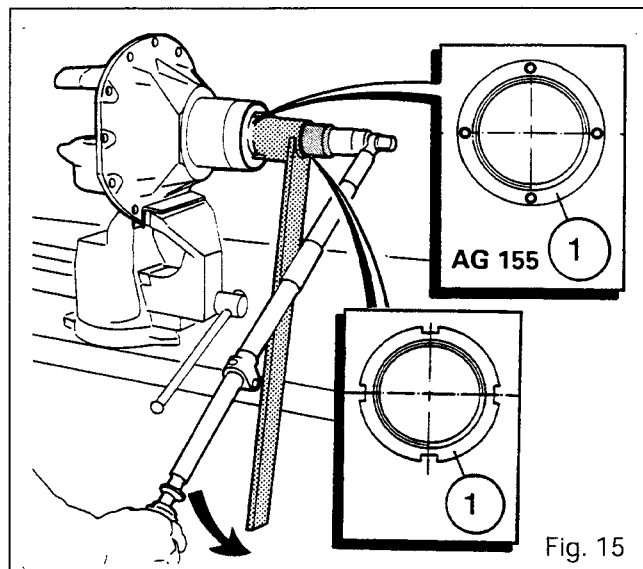



## H. Reassembling the differential lock

56. Remove the friction washer (16) on the mobile dog tooth coupler (18), and then fit the assembly in the piston (14). Fit the tab washer (12) and position the retaining ring (13) in the groove on the coupler.
57. In the housing without seals, install the piston (14) with the coupler (18).

**Note: The dowel (34) is force-fitted in the piston. Check that the piston and the dowel slide freely in the housing. When this check has been carried out, remove the piston with the coupler.**

58. Fit new O-rings (15) and (19). Position the piston with the coupler and then insert it by striking it around the edge with a plastic mallet.
59. Position the spring (17) and the washer (20), with the shoulder of the washer facing the spring. Tighten the assembly using tool MF471 until the washer (21) slides freely in the groove on the housing.
60. Loosen the tool, taking care that the spring does not escape.
61. If the bearing cone (33) was removed, fit it on the half housing (26) using a press or a suitable fixture (Fig. 17).
62. Fit the other bearing cone (33) on the cover (24), if it was removed.
63. Assemble the half housing (25) in the cover (24) (with the coupler teeth) in accordance with the markings made before disassembly.
64. Position the washer (35) on the sun gear (11), and place the assembly in the half housing (25), engaging the tab on the washer in one of the holes in the half housing.
65. Place the planetary pinions (38) (2 or 4 of them according to the category) and the washers (37) on the pin or pins (36). Then position the assemblies in the half housing (25), engaging the tabs on the washers (37) in the holes in the half housing (25) (Fig. 6A or 6B).
66. Place the other washer (35) on the other sun gear (11). Fit the assembly in the half housing (26), making sure that the tab of washer (35) is correctly positioned.
67. Position the half housing assembly (26) on half housing (25), in accordance with the assembly position marked before disassembling.

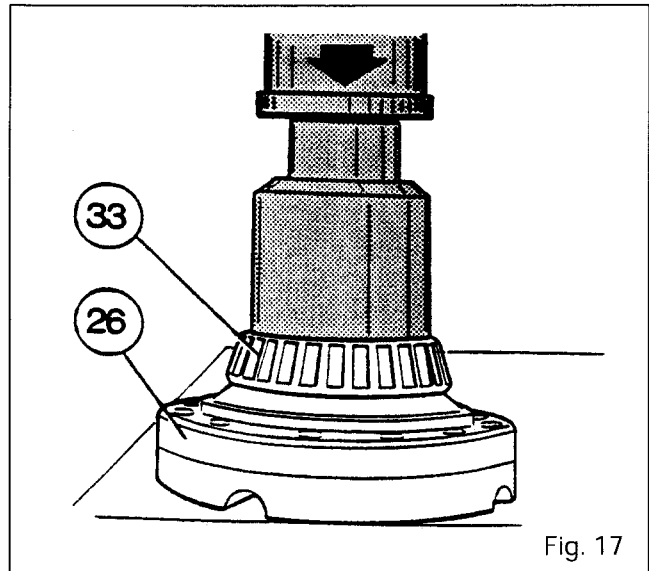

Fig. 17

68. Position the crownwheel (27) on the half housing (26). Assemble the half housings (25) and (26), the cover (24) and the crownwheel. Fit the bolts (23) and apply Loctite 270. Tighten the nuts (28) to a torque of 82 to 90 Nm.
69. Position the bearing cups (29) on their cones (33).
70. Place the shims (22) on washer (21).



## Front axle - Differential

71. Place the crownwheel assembly in the housing **(7)** (Fig. 5). Check that the centring bushes **(44)** are in place. Position the half bearings **(43)**. Moderately tighten the bolts **(42)** so that the cups **(29)** can be moved freely
72. Install the housing in the horizontal position in a soft-jawed vice, with the crownwheel facing upwards (Fig. 18).
73. Install a dial gauge. Tighten the nut **(32)** (Fig. 18) and rotate the crownwheel through several turns in order to correctly seat the bearing cones in the cups. Retighten the screw in order to take up the end play.
74. Tighten the nut **(32)** by three more slots in order to obtain a satisfactory preload.
75. Check the backlash on the crownwheel and the drive pinion with a dial gauge (Fig. 19). Take three readings at three equidistant points. Calculate the average of the three readings to obtain a backlash of 0.18 to 0.23.  
If the measured value is too high, reduce the thickness of shims **(22)**. If it is too low, increase the thickness of shims until a satisfactory reading is obtained.
76. Disassemble the bearing screws **(42)** one by one, coat them with Loctite 270 and tighten them to between 115 and 127 Nm.
77. Reinstall the locking plate **(31)** with the bolts **(30)** coated with Loctite 270, and tighten to between 16 and 25 Nm. Lock the nut **(32)** by bending the tab of the locking plate in the appropriate groove.

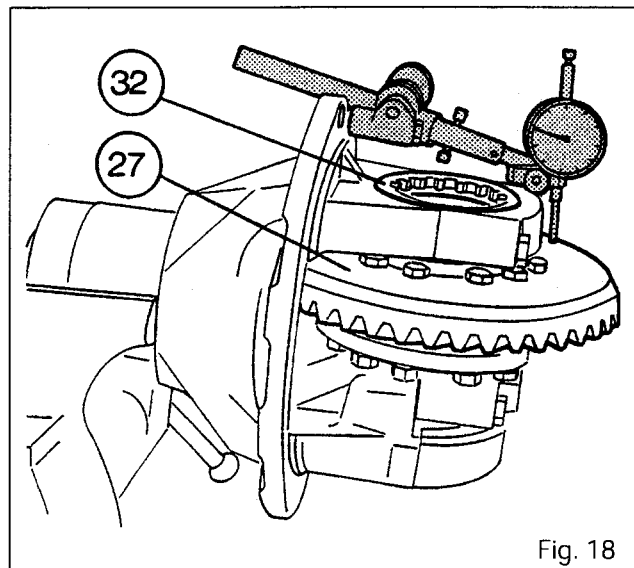

Fig. 18

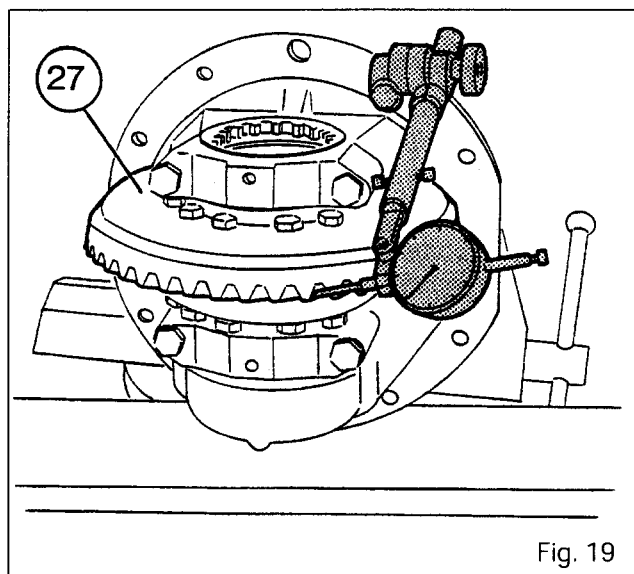

Fig. 19

### I. Piston leak test

78. Connect a pressure gauge equipped with a valve to the supply connector of the differential lock.
79. Supply the circuit with compressed air at approximately 5 bar and check the movement of the piston **(14)**.  
Reduce the pressure to 0.3 bar and close the valve.  
The pressure gauge should not show any pressure drop for 1 minute.
80. Remove the pressure gauge and valve assembly.





8C01.14

---

## 6100 SERIES TRACTORS

---



### Front axle - Differential

---

#### J. Refitting the differential housing assembly

---

81. Clean and check the parts. Replace any which are faulty.
82. Check that the centring bushes are installed on the axle housing.
83. Smear a sealing compound, Loctite 510 or equivalent, on the differential housing mating face with the axle housing, and screw in two diametrically opposed guide studs.
84. Reinstall the differential housing assembly **(7)** (Fig. 3). Remove the guide studs. Fit and tighten the bolts **(1)** (Fig. 3) to a torque of 125 to 140 Nm.
85. Reinstall the steering ram. Smear the attaching bolts with Loctite 270 and tighten them to a torque of between 180 and 200 Nm.

---

#### K. Refitting the swivel housing, wheel hubs and drive shafts (Fig. 1)

---

86. If the seals **(8)** were removed, fit them fully home against the shoulder. Replace the O-rings **(40)** and seals **(6)** and **(12)**.
87. Lubricate seal **(8)**. With the help of another person, fit the assemblies. Slide the universal drive shafts in the axle housing without damaging the seals. Insert a guide through the oil filling hole to align the left-hand drive shaft with the differential.
88. Turn the wheel hubs in order to engage the drive shafts.
89. Smear the pin **(7)** with anti-seize grease and position it so that the swivel housing assembly **(47)** is aligned with the axle housing **(52)**. Fit the pin.
90. Fit the bearing cup **(4)**, the shims **(3)** and the cover **(2)**. Fit and tighten the bolts **(1)** evenly and alternately.
91. Fit the pin **(11)** smeared with anti-seize grease, checking that the lip of seal **(12)** (Fig. 1) is correctly positioned. Position the bearing cup **(14)** and the cover **(15)**. Fit the bolts **(1)** and tighten them to between 115 and 140 Nm in the same way as in procedure 90.

92. Check that the swivel pins **(7)** and **(11)** are correctly in contact with the housing.
93. Remove the cover **(2)**. Take out the shims **(3)** and the cup **(4)**. Smear the cone **(5)** with bearing grease. Reinstall the top, the shims and the cover. Tighten the bolts **(1)** to between 115 and 140 Nm. Using a pump, grease the bearing **(13)**, **(14)**.
94. Reinstall the steering ball joints. Tighten the nuts to a torque of between 115 and 130 Nm. Lock the nuts with new pins.

---

#### L. Recoupling the front axle and frame

---

95. Recouple the axle and its bearings on the front frame (see Section 8F01).
96. Top up the oil level in the axle housing and check the oil level in the reduction units.
97. Carry out a road test on the front axle and the differential lock control.
98. Check the following for leaks:
  - seals and the mating face of the differential housing,
  - hydraulic couplings.



## Front axle - Differential

### M. Service tools

1. Tool available from MF network  
**MF451B - Swivel extractor (Fig. 20)**

**MF451B3 - End fitting for extractor M18 (Fig. 20)**

**MF471 - Differential locking spring compression tool (Fig. 21)**

**3376881M1 - Clamping tool for drive pinion nut, axles AG 105 - AG 125 (Fig. 22)**

**3376927M1 - Clamping tool for drive pinion nut, axles AG 85 (Fig. 22)**

**3378051M1 - Clamping tool for drive pinion nut, axles AG 155 (Fig. 23)**

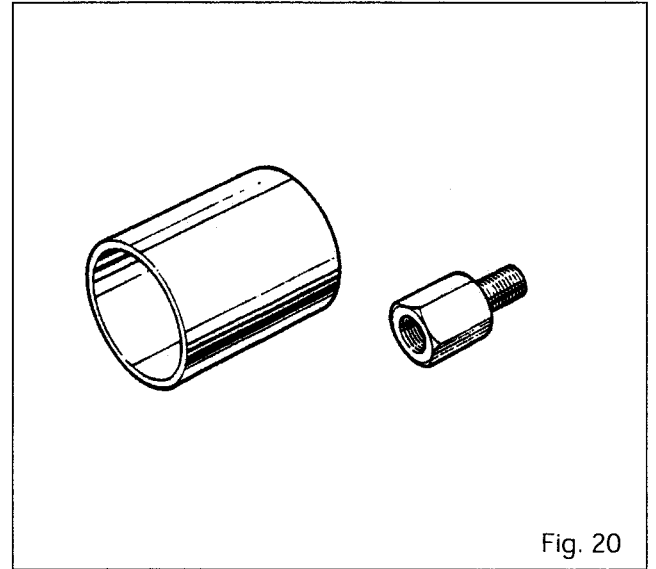

Fig. 20

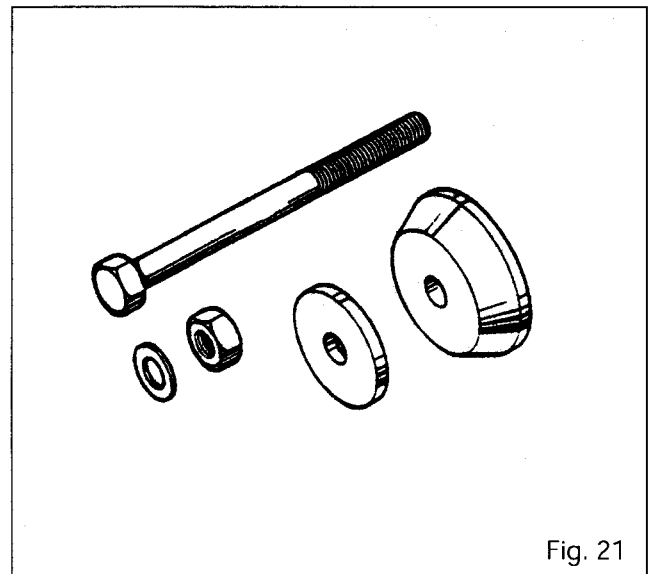

Fig. 21

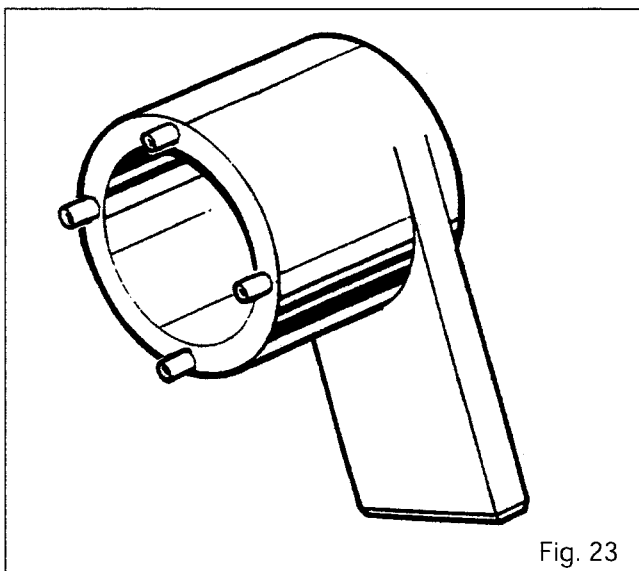

Fig. 23

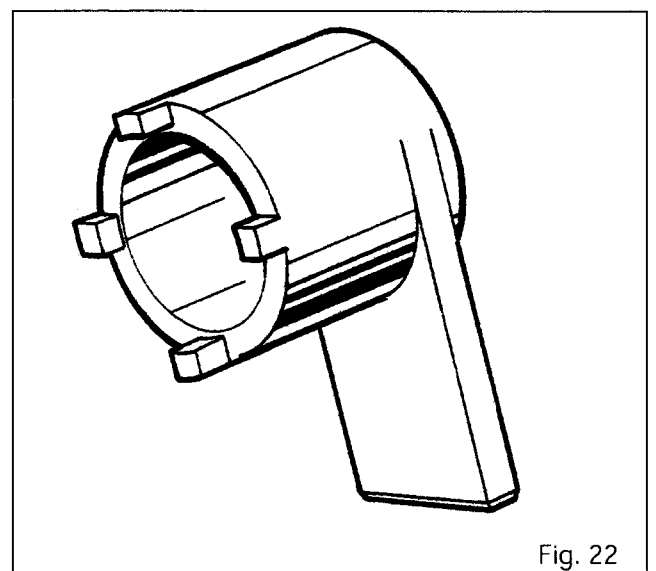

Fig. 22



8C01.16

6100 SERIES TRACTORS



**Front axle - Differential**

2. Tools to be manufactured locally

**Special wrench for splined nut**

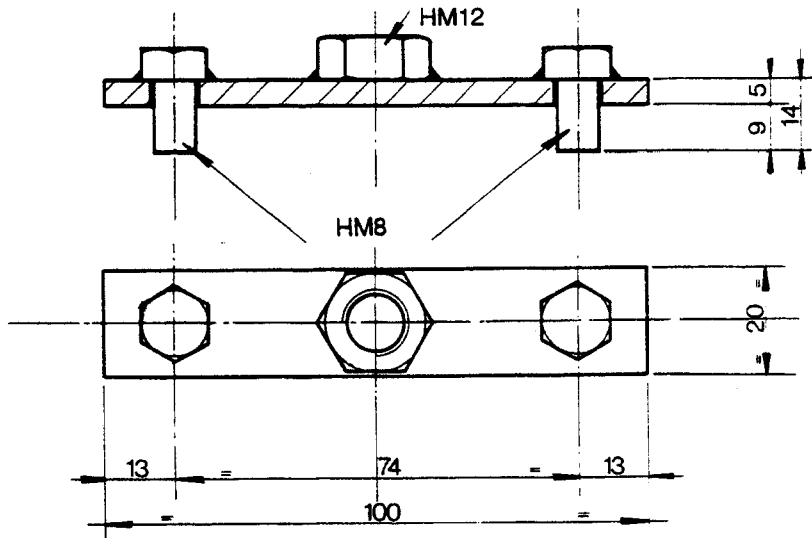

**Special sleeve for tightening and torque of drive pinion**

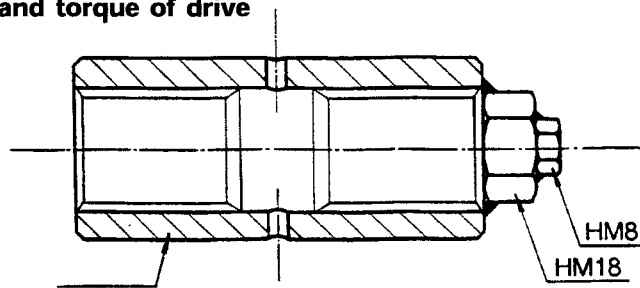

Sleeve: 3380056 M2 (AG 105 - AG 125)  
 3384857 M2 (AG 85)  
 3714416M1 (AG 155)

**Seal fitting drift**

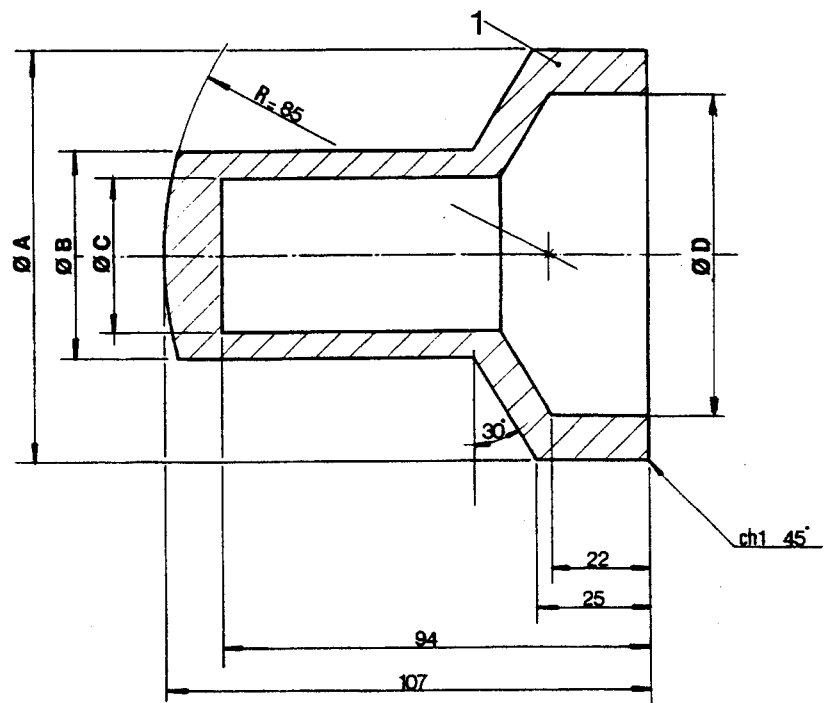

	Ø A	Ø B	Ø C	Ø D
AG 85	81.80	40	28.54 <sup>+0.5/0</sup>	68
AG 105	81.80	47	34.90 <sup>-0.5/0</sup>	68
AG 125				
AG 155	91.80	47	34.90 <sup>+0.5/0</sup>	72



---

**6100 SERIES TRACTORS**

---



8D01.1

**Front axle - 2 WD Front axle**
**8 D01 2WD front axle**
**CONTENTS**

-	<b>General</b> _____	<b>2</b>
A.	<b>Removal and refitting of steering arm ball joint</b> _____	<b>5</b>
B.	<b>Removal and refitting of hub, spindle and spindle arm</b> ..	<b>5</b>
C.	<b>Removal and refitting of steering ram</b> _____	<b>7</b>
D.	<b>Removal and refitting of front axle</b> _____	<b>7</b>
E.	<b>Adjustment of toe-in</b> _____	<b>9</b>
F.	<b>Track adjustment</b> _____	<b>9</b>
G.	<b>Service tool</b> _____	<b>10</b>



# 6100 SERIES TRACTORS



8D01.2

## Front axle - 2 WD Front axle

### General

The front axle comprises the following parts:

- A cast support identical to that of the 4-wheel-drive version, whose lower rear part comprises a bearing supporting the 2nd steering swivel pin (4-cylinder engine) or a removable swivel pin (6-cylinder engine).
- A front bearing fixed on the cast support holding the 1st steering swivel pin.
- An axle beam articulated on two swivels.
- Two spindle arms.
- Two spindles mounted in the bores of the spindle arms.
- A double acting ram linked to the spindles by two steering arms.

There are two axle versions depending on the type of tractor:

#### MF 6610-6120-6130-6140

Standard axle with 6-hole hub.

#### MF 6150

Standard axle with 6-hole hub or heavy-duty axle with 8-hole hub.

#### MF 6160-6170-6180-6190

Heavy-duty axle with 8-hole hub.

### List of parts

	Version			Version	
	standard 6-hole hub	heavy-duty 8-hole hub		standard 6-hole hub	heavy-duty 8-hole hub
(1) Pin	•		(19) Bearing cone	•	•
(2) Nut	•	•	(20) Hub	•	•
(3) Washer	•	•	(21) Bearing cup	•	•
(4) Bearing cone	•	•	(22) Cover	•	•
(5) Spindle	•	•	(23) Rivet	•	•
(6) Bearing cup	•	•	(24) Nut		•
(7) Dust cap	•	•	(25) Washer		•
/8\ Thrust washers	•		(26) Belleville washers		•
(9) Grease nipple	•	•	/27\ Sealing ring		•
(10) Nut	•	•	(28) Bearing cone		•
(11) Axle Beam	•	•	(29) Bearing cup		•
(12) Steering arm	•	•	/30\ Sealing ring		•
(13) Seal	•		(31) Lock washer		•
(14) Bush	•	•	(32) Spacers	•	•
(15) Spindle arm	•	•	(33) Screw	•	
(16) Bush	•		(34) Washer	•	
(17) Washer	•		(35) Nut	•	
/18\ Sealing ring	•	•	(36) Bolt	•	•
			(37) Steering ram	•	•
			(38) Screw	•	•
			(39) Washers	•	•
			(40) Nuts	•	•
			(41) Sleeve	•	•
			(42) Screw	•	•
			(43) Steering rod	•	•
			(44) Screw	•	•
			(45) Nuts	•	•
			(46) Sleeve	•	•
			(47) Pin	•	•
			(48) Washer	•	•
			(49) Nut	•	•
			(50) Ball joint	•	•
			(51) Pin	•	•
			(52) Nut	•	•
			(53) Ball joint	•	•
			(54) Support	•	•
			(55) Bush	•	•
			(56) Thrust washer	•	•
			(57) O-ring	•	•
			(58) O-ring	•	•
			(59) Nut	•	•
			(60) Lock nut	•	•
			(61) Bushes	•	•
			(62) Grease nipple	•	•
			(63) Washer	•	•
			(64) Bush	•	•
			(65) Spacer	•	•



6100 SERIES TRACTORS

Front axle - 2 WD Front axle



8D01.3

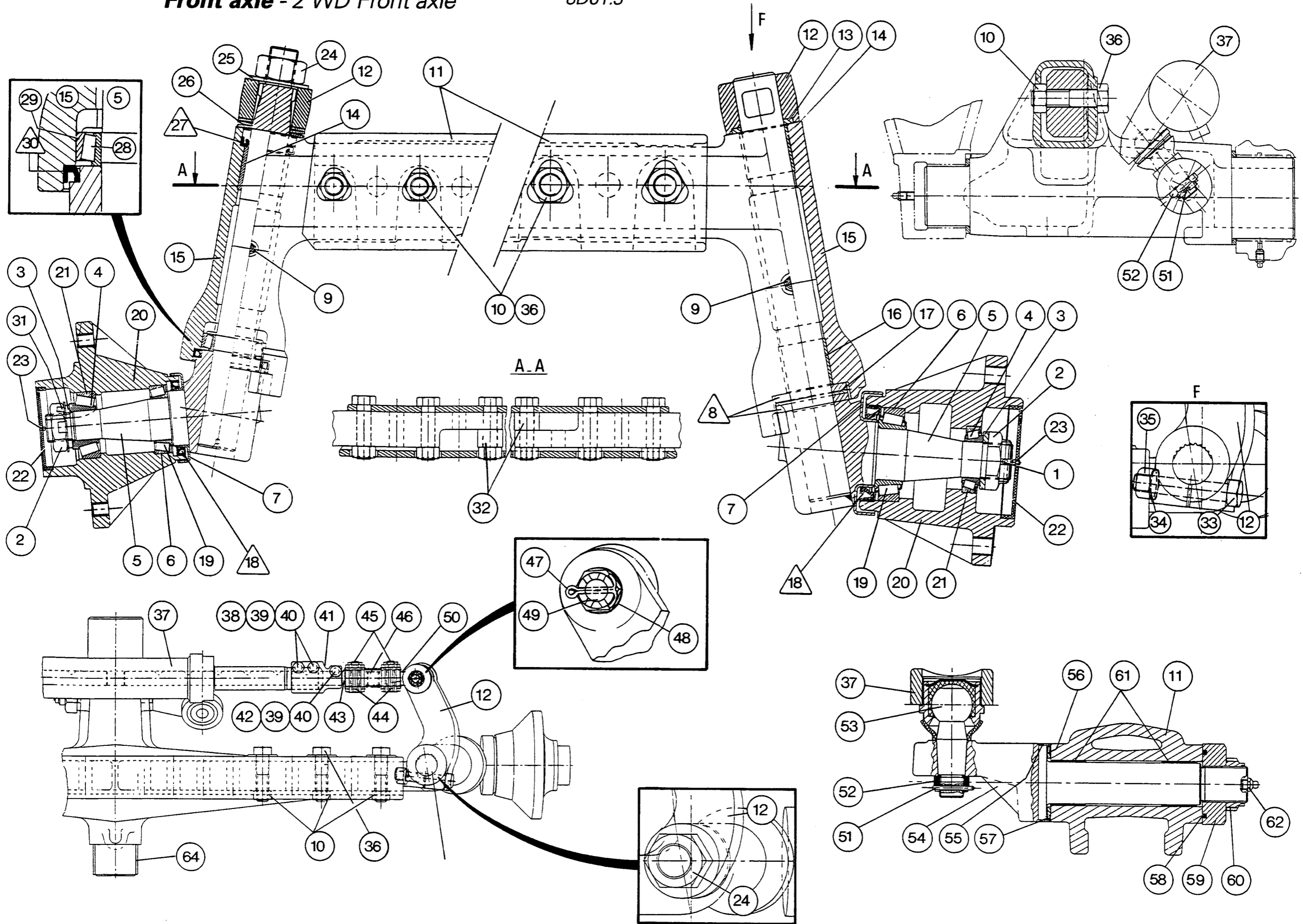



6100 SERIES TRACTORS



8D01.4

Front axle - 2 WD Front axle

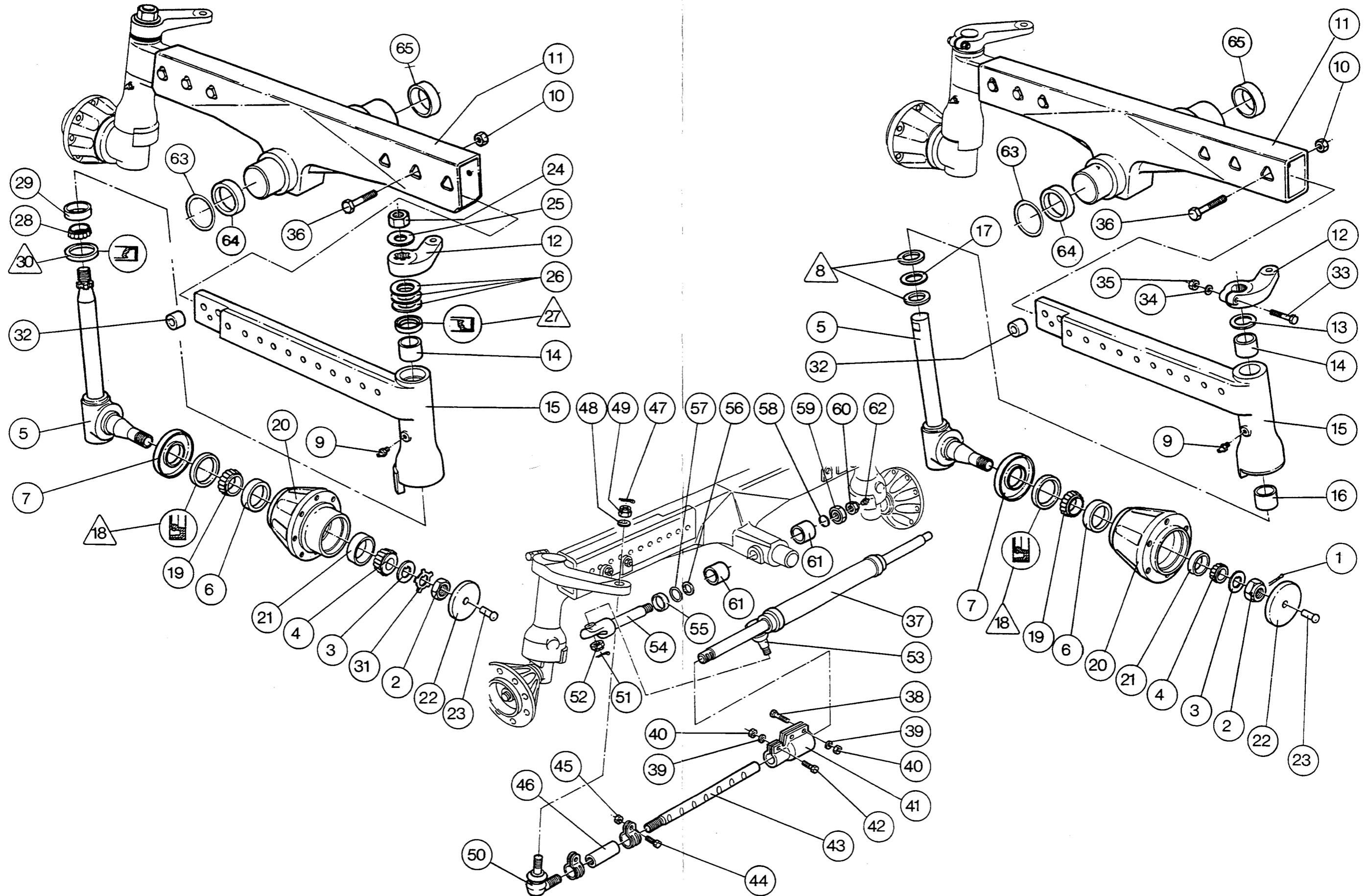



## 6100 SERIES TRACTORS



8D01.5

### Front axle - 2 WD Front axle

#### A. Removal and refitting of steering arm ball joint

##### Removal

1. Chock the rear wheels and apply the handbrake.
2. Lift the relevant wheel with a jack. Remove the pin (47), the nut (49) and the washer (48).
3. Extract the ball joint (50) from the steering arm (12).
4. Loosen the nuts (45), turn the sleeve (46) in order to separate the ball joint (50) from the rod (43).

##### Refitting

5. Clean and check the parts. Replace any which are defective.
6. Mount the ball joint (50) in the steering arm (12).
7. Couple the sleeve (46) to the rod (43) and the ball joint (50).
8. Fit the washer (48), tighten the nut (49) to a torque of 108 - 122 Nm and lock it with the pin (47).
9. Remove the jack.
10. Remove the chocks and release the handbrake.
11. Adjust the toe-in (see section E).

#### B. Removal and refitting of hub, spindle and spindle arm

##### Removal

12. Chock the rear wheels and apply the handbrake.
13. Lift the front of the tractor with a jack positioned in the axis of the axle and insert props.
14. Remove the relevant wheel.
15. Extract the cover (22).
16. Remove the pin (1), loosen the nut (2), remove the washer (3) (standard axle).  
Release and loosen the nut (2), remove the lock washer (31), remove the washer (3) (heavy-duty axle).
17. Remove the bearing cone (4).
18. Remove the wheel hub (20) from the spindle (5).
19. Extract the sealing ring /18\ and remove the bearing cone (19).
20. Extract the cups (6) and (21) from the hub (20).
21. Remove the dust cap (7).

There are 2 axle versions :

##### MF 6110 to 6140

Standard axle with 6-hole hub...

##### MF 6150

Standard axle with 6-hole hub or heavy-duty axle with 8-hole hub.

##### MF 6160 to 6190

Heavy-duty axle with 8-hole hub.

##### Standard axle with 6-hole hub

22. Remove the nut (35), the washer (34) and the screw (33).
23. Withdraw the steering arm (12) from the spindle (5).
24. Withdraw the spindle (5) from the spindle arm (15).
25. Remove the washers /8\ and (17).
26. Extract the rings (14) and (16) from the arm (15).

##### Heavy-Duty axle with 8-hole hub

27. Remove the nut (24) and the washer (25).
28. Withdraw the steering arm (12) from the spindle (5). Remove the Belleville washers (26).
29. Withdraw the spindle (5) from the spindle arm (15).
30. Separate the bearing cone (28) from the spindle (5).
31. Extract the sealing rings /30\ and /27\ from the spindle arm (15).
32. Extract the bush (14) and the cup (29) from the arm (15).

##### Standard or heavy-duty axle

33. Remove the screw (36) and the nuts (10).
34. Withdraw the spindle arm (15) from the axle beam (11), remove the grease nipple (9).





## 6100 SERIES TRACTORS



8D01.6

### Front axle - 2 WD Front axle

#### Refitting

##### Standard or heavy-duty axle

35. Clean and check the parts. Replace any which are defective.
36. Mount the spindle arm (15) in the axle beam (11), fasten it with screws (36) and nuts (10) placed in the seats of the axle.  
Tightening torque of screws (36):
  - Standard axle : 350 - 430 Nm
  - Reinforced axle : 400 - 600 Nm

##### Standard axle with 6-hole hub

37. With a punch, push in the bushes (14) and (16) against the shoulder in the spindle arm (15).
38. Fit the dust cap (7) on the spindle (5).
39. Place washers /8\ and (17) on the spindle, orientate the lubricating grooves of washers /8\ towards washer (17).
40. Introduce the spindle (5) into the arm (15).
41. Place the seal (13) in the seat of the steering arm (12).
42. Fit the steering arm (12) on the spindle (5).
43. Position the screw (33) in the recess in the spindle (5), fit the washer (34). Tighten the nut (35) to a torque of 250 - 300 Nm.  
**Note: Ensure that the spindle (5) is fitted without any play.**

##### Heavy-duty axle with 6- or 8-hole hub

44. With a punch, push in the bush (14) against the shoulder in the spindle arm (15).
45. Push in the sealing ring /27\ against the shoulder in the spindle arm with the lip facing outwards.
46. Push the dust cap (7) on the spindle (5).
47. Position the bearing cup (29) in the spindle arm.
48. Push the sealing ring /30\ in the spindle arm with the lip facing outwards.
49. Push the bearing cone (28) on the spindle, then introduce the spindle into the spindle arm.
50. Position the Belleville washers (26), the steering arm (12) and the washer (25). Smear the nut (24) with Loctite 241, tighten to a torque of 550-580 Nm.

##### Standard or heavy - duty axle

51. Using a press or an appropriate device push the cups (6) and (21) against the shoulder in the hub (20).
52. Grease the bearing cone (19) (MF1105 grease or equivalent) and place it in the cup (6).

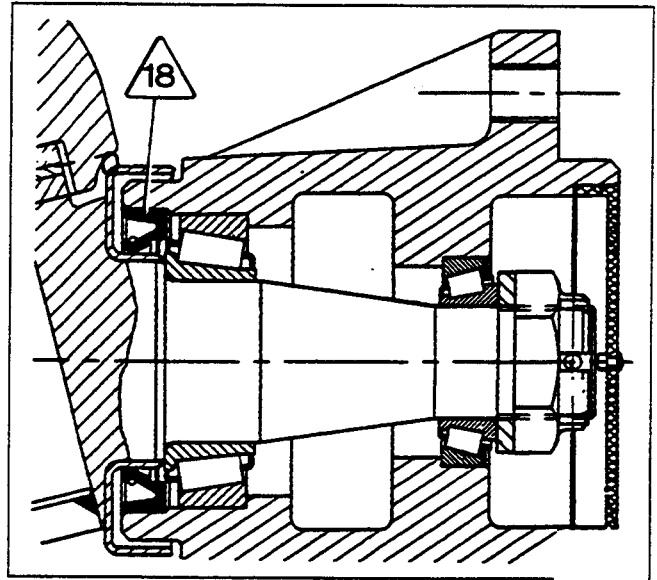

53. Push the sealing ring /18\ into its seat against the shoulder, the lip turned outwards (Fig. 1).
54. Fill the cavity of the hub (20) with MF1105 grease or equivalent.
55. Mount the wheel hub (20) on the spindle (5).
56. Grease the bearing cone (4) (MF1105 grease or equivalent) and place it on the spindle in contact with the bearing cup (21).
57. Position the washer (3), the nut (2) (standard axle), the lock washer (31), the nut (2) (heavy-duty axle). After tightening the nut to a torque of 81 Nm, slacken it by 1/12 to 1/16 of a turn to obtain play of between 0 and 0.13.
58. Lock the nut (2) on the spindle with the pin (1) (standard axle). Bend back the tab of the lock washer (31) on the nut (2) (heavy-duty axle).
59. Check that the hub turns smoothly.
60. Fill the cavity of the hub (20) (nut side) with MF1105 grease or equivalent.
61. Close the hub with the cover (22).
62. Clinch a rivet (23) in the hole of the cover. Fit the grease nipple (9).
63. Refit the wheel, remove the props and tighten the bolts to a torque of 140 - 200 Nm. Grease the spindle arm (15).
64. Remove the chocks and release the handbrake.
65. Adjust the toe-in (see section E).



## Front axle - 2 WD Front axle

### C . Removal and refitting of steering ram

#### Removal

66. Chock the rear wheels and apply the handbrake. Lift the front of the tractor with a jack positioned in the axis of the axle.
67. Disconnect and block the ram supply hoses.  
**Note: Mark the position of the hoses before removal.**
68. Loosen the nuts (45), turn the sleeves (46) to separate the ball joints (50) from the steering rods (43).
69. Remove the pin (51) and the nut (52). Withdraw the ball joint (53) from the support (54).
70. Remove the steering ram assembly.
71. Unscrew the ball joint (53) (if necessary).
72. Dismantle the nuts (40), the washers (39) and the screws (38). Separate the sleeves (41) equipped with rods (43).

#### Refitting

73. Clean and check the parts. Replace any which are defective.
74. Assemble the sleeves (41) equipped with rods (43) on the ram. Fit the screws (38) and washers (39) and tighten the nuts (40).
75. Screw the ball joint (53) (if fitted) on the steering ram.
76. Refit the ram assembly on the support (54).
77. Tighten the nut (52) of the ball joint to a torque of 100-120 Nm and fit the pin (51).
78. Couple the sleeves (46) to the rods (43) and to the ball joints (50).
79. Connect the ram supply hoses.
80. Withdraw the jack. Remove the chocks and release the handbrake.
81. Adjust the toe-in (see section E).
82. Check for leaks of the ram connectors.

### D . Removal and refitting of front axle

#### Removal

83. Chock the rear wheels and apply the handbrake.
84. Lift the front of the tractor with a jack positioned in the axis of the axle.
85. Position a stand under the crankcase.
86. Remove the front wheels.
87. Remove the screws (36) and the nuts (10).
88. Remove the nuts (40), the washers (39) and the screws (38).
89. Remove the assemblies (1) (Fig. 2).
90. Remove the pin (51) and the nut (52), withdraw the ball joint (53) from the support (54), detach the ram from the axle (11).
91. Hoist the axle (Fig. 3).

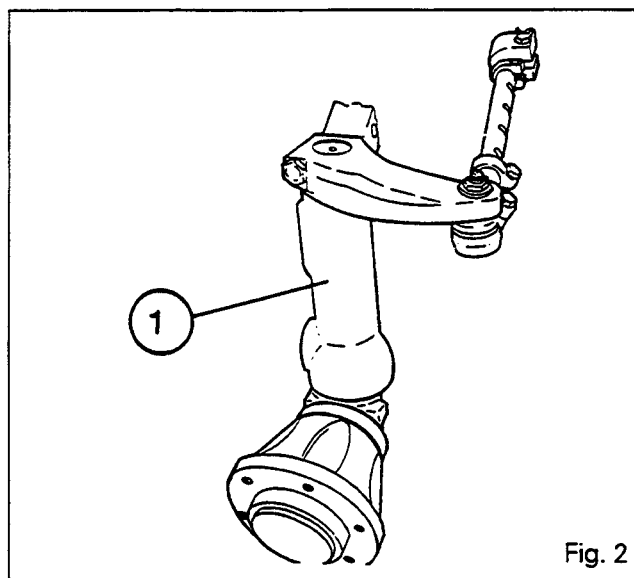

Fig. 2



8D01.8

## Front axle - 2 WD Front axle

92. Remove the screws (1) and the grease nipple (3). Remove the front bearing (2) and the washer (63) (Fig. 4).
93. Remove the front axle, disengaging it from its rear bearing (5) with the spacer (65) (Fig. 4).
94. Remove the lock nut (60) and the nut (59) with its seal (58), remove the support (54). The bush (55), the thrust washer (56) and the o-ring (57) remain on the support (54).
95. If necessary, withdraw the bushes (61) from the axle.  
**Note : The bush (64) is force fitted on the axle beam (11).**

### Refitting

96. Clean and check the parts. Replace any which are defective.
97. If necessary, fit the bushes (61) with a locally made tool (see section G). Fit the bush (64), chamfer positioned towards the axle beam.
98. Position the bush (55), the thrust washer (56) and the seal (57) and refit the support (54).
99. Tighten the nut (59) with O-ring (58) on the support (54), then slacken it so as to obtain axial play of 0.05 to 0.25.
100. Using a spanner wrench, tighten the lock nut (60) to 120-150 Nm. Check that the support swivels freely.
101. Hoist the axle. Position the spacer (65) (the chamfer facing the axle side, Fig. 4). Fit the axle in the support (5).
102. Position the washer (63) (the chamfer facing the axle side, Fig. 4). Mount the front bearing (2) so as to eliminate play between the washer and the axle as far as possible.
103. Smear the screws (1) with Loctite 270. Tighten to a torque of 540-620 Nm. Detach the hoist.
104. Fit the grease nipple (3) (Fig. 4).
105. Refit the ram assembly (37) on the support (54). Tighten the nut (52) to a torque of 100-120 Nm and fit the pin (51).
106. Grease the bearings (2) and (5) (Fig. 4) and the ram support (54).
107. Grease the rods (43) with molybdenum disulphide. Refit the assemblies (1) (Fig. 2). Fit the nuts (10) and the screws (36). Tighten to a torque of :  
- Standard axle : 350-430 Nm  
- Heavy-duty axle : 400-600 Nm
108. Fit the screws (38), the washers (39) and the nuts (40). Tighten to a torque of 75-81 Nm.
109. Refit the front wheels. Remove the stand under the crankcase. Tighten the bolts to a torque of 140-200 Nm.
110. Remove the chocks and release the handbrake.
111. Adjust the toe-in (see section E).

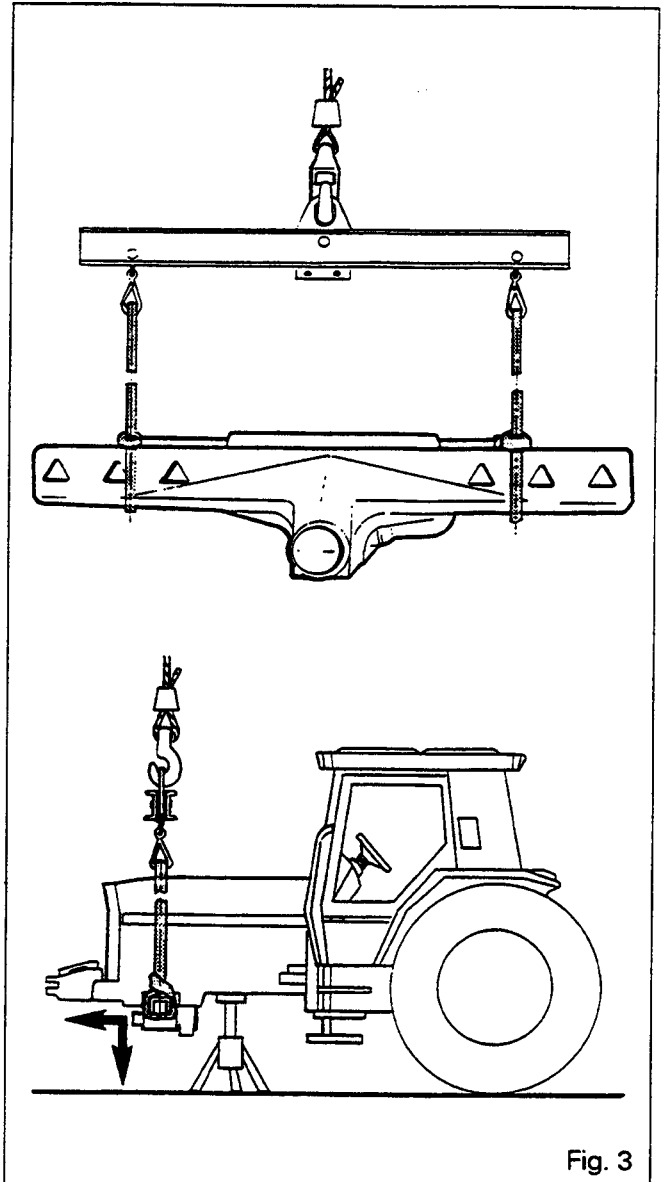
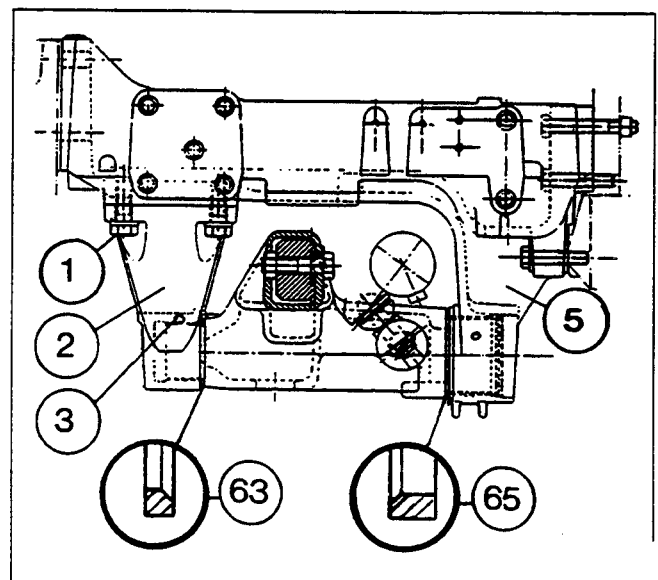

Fig. 3





## Front axle - 2 WD Front axle

### E. Adjustment of toe-in

112. Set the steering to the central position. It is necessary to adjust the sleeves (46) so as to obtain a toe-in of 0 to 14 mm. The toe-in is measured at points A,A' and B,B', determined by a diameter of 895 mm traced on the flanks of the tyres (Fig. 5). It is obtained from the difference of the two values L and D.

**Note: If the toe-in is measured on a diameter other than 895 mm, correct the value accordingly. Once adjustment has been carried out, tighten the nuts (45) to a torque of 45-55 Nm.**

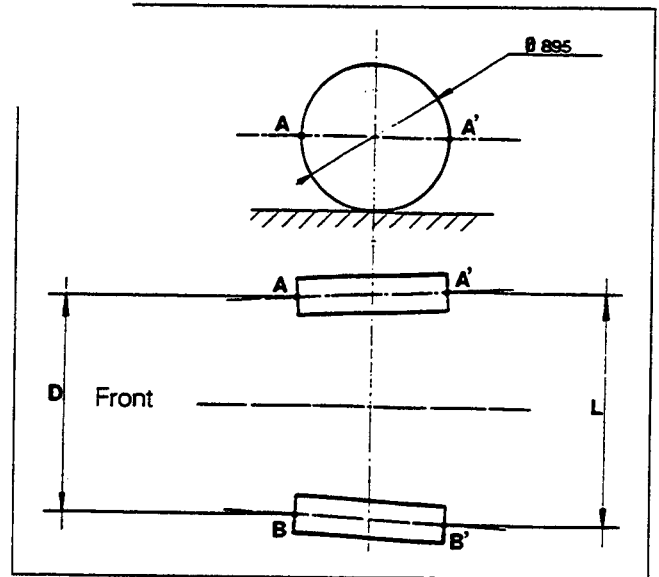

### F. Track adjustment

113. Lift the front of the tractor in the axis of the axle.

114. Remove the screws (36) and (42) and the nuts (10) and (40) (Fig. 6).

115. Place the spindle arms in the desired position.

116. Fit the bolts (36). Tighten to a torque of :  
 - Standard axle : 350-430 Nm  
 - Heavy-duty axle : 400-600 Nm

117. Fit the rods (43) according to the position of the arms.

Fit the screws (42), the washers (39) and the nuts (40). Tighten to a torque of 75-81 Nm.

**Note: When the tractor is used with the widest track, the spacer (32) must be used when fitting the 3rd screw (36) (Fig. 7).**

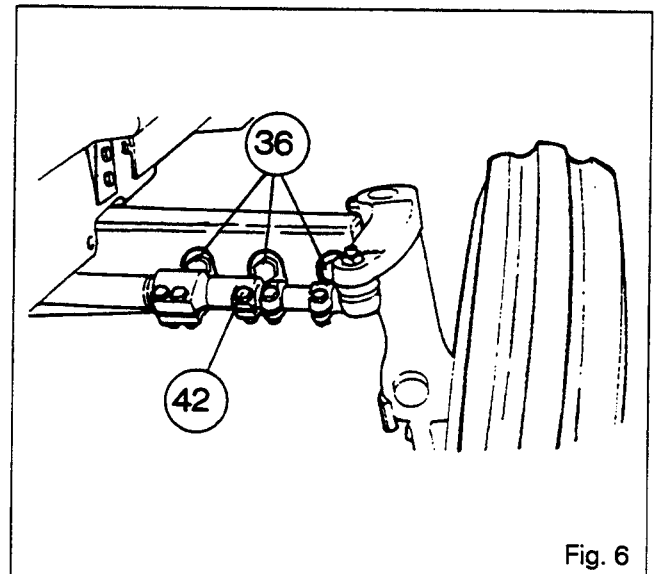

Fig. 6

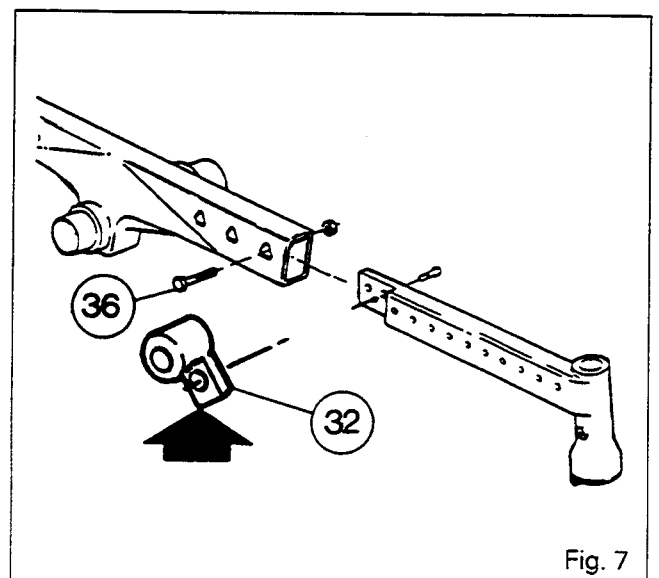

Fig. 7



8D01.10

6100 SERIES TRACTORS



**Front axle - 2 WD Front axle**

**G. Service tool**

Tool to be made locally

Bush replacer

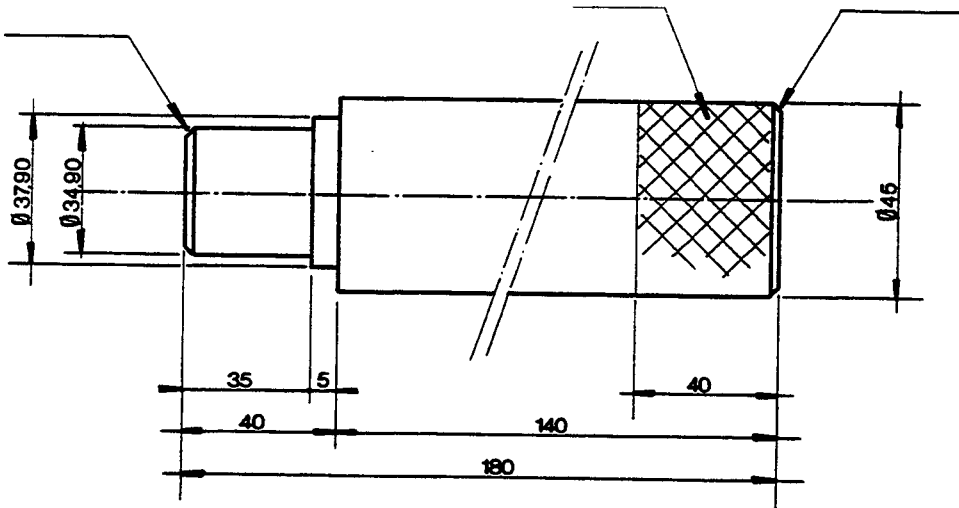

**Front axle - Steering column**

8E01.1

**8 E01 Steering column**
**CONTENTS**

-	<b>General</b> _____	<b>2</b>
-	<b>Operation</b> _____	<b>2</b>
A.	<b>Removing and refitting the steering column</b> _____	<b>5</b>
B.	<b>Disassembling and reassembling the control lever assembly</b> _____	<b>5</b>
C.	<b>Removing and refitting the notched lever and rack</b> _____	<b>5</b>
D.	<b>Disassembling and reassembling the locking mechanism</b> _____	<b>6</b>
E.	<b>Replacing the shafts and bearings</b> _____	<b>6</b>
F.	<b>Replacing the guide bushes</b> _____	<b>7</b>



## 6100 SERIES TRACTORS



8E01.2

### Front axle - Steering column

#### General

The steering column assembly consists of the following two sections:

- the fixed lower section comprising a tube and an attaching base plate,
- the moving upper section comprising a tube and a welded yoke as well as a housing including the steering wheel height and tilt adjusting mechanisms.

#### Operation

##### Height adjustment

When the control rod (4) is moved to the high position, rod T causes the elbow lever (8) to swivel and lower arm (15) which is hinged on pin (14).

Adjusting screw [5] attached to the arm bears on the lock plate (16) which is released, allowing the upper section of the steering column to move.

The spring (3) returns the control lever (4) to its initial position.

The stop (25) limits the movement of both sections.

##### Tilt adjustment

When the control lever (4) is moved to the low position, it presses on rod T which pushes on the end of the notched lever (9) and frees it from the rack /10\ allowing it to tilt the housing (20). The two return springs (17) allow the positioning of the steering wheel.

Adjusting screw [5] allows the meshing of the teeth on the rack /10\ and notched lever (9) to be adjusted.

#### List of parts

- (1) Retaining washer
- (2) Retaining washer
- (3) Spring
- (4) Control lever assembly
- [5] Adjusting screw
- (6) Bolt
- (7) Spring
- (8) Elbow lever
- (9) Notched lever
- /10\ Rack
- (11) Pin
- (12) Upper shaft
- (13) Retaining washer
- (14) Pin
- (15) Arm
- (16) Lock plate
- (17) Springs
- (18) Pin
- (19) Pin
- (20) Housing
- (21) Moving column
- (22) Bearings
- (23) Circlip
- (24) Bolt
- (25) Stop
- (26) Bush
- (27) Bush
- (28) Fixed column
- (29) Lower shaft
- (30) Bushes
- (31) Circlip



6100 SERIES TRACTORS



Front axle - Steering column

8E01.3

Overall view

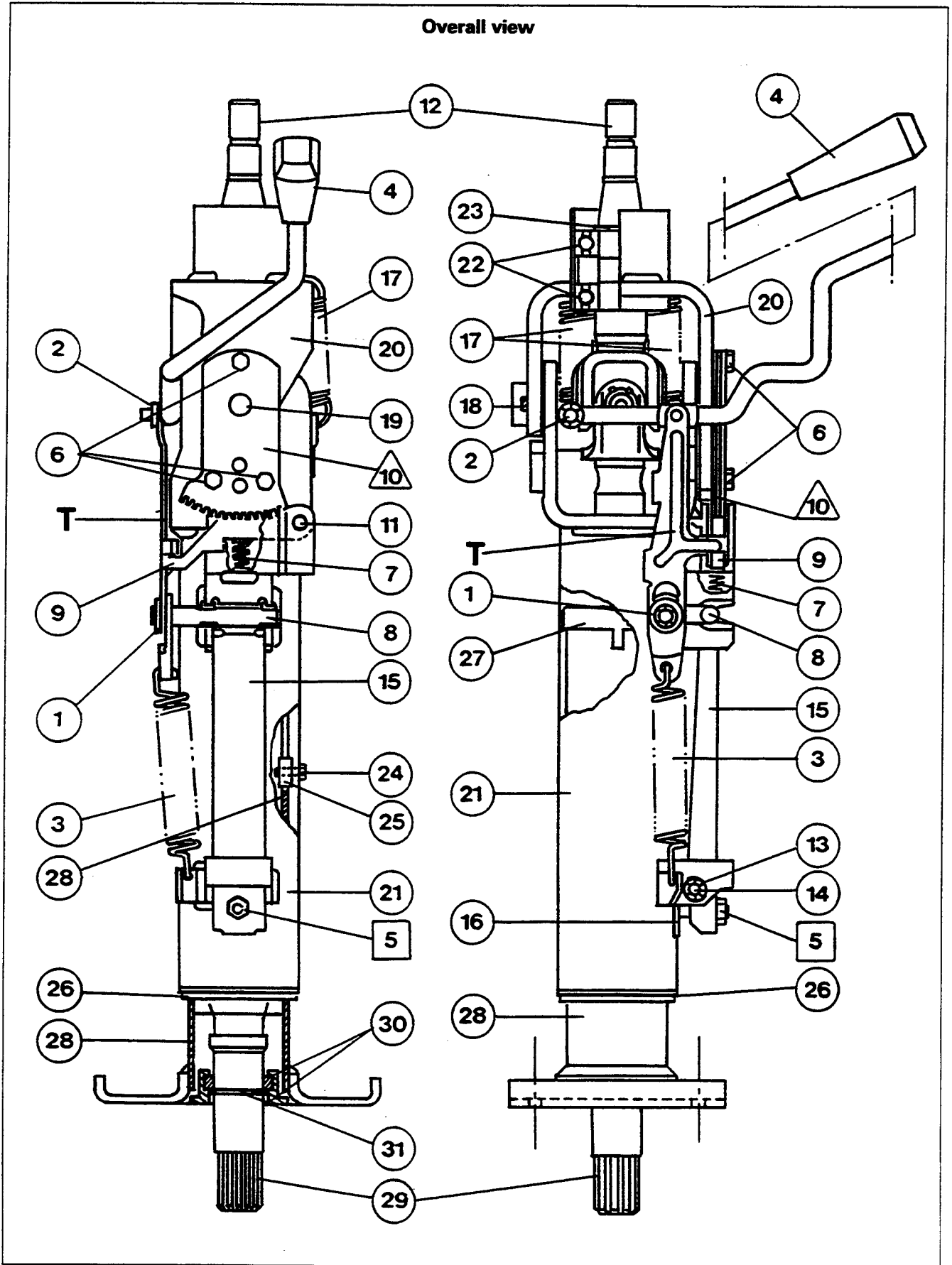





6100 SERIES TRACTORS



8E01.4

Front axle - Steering column

Exploded view

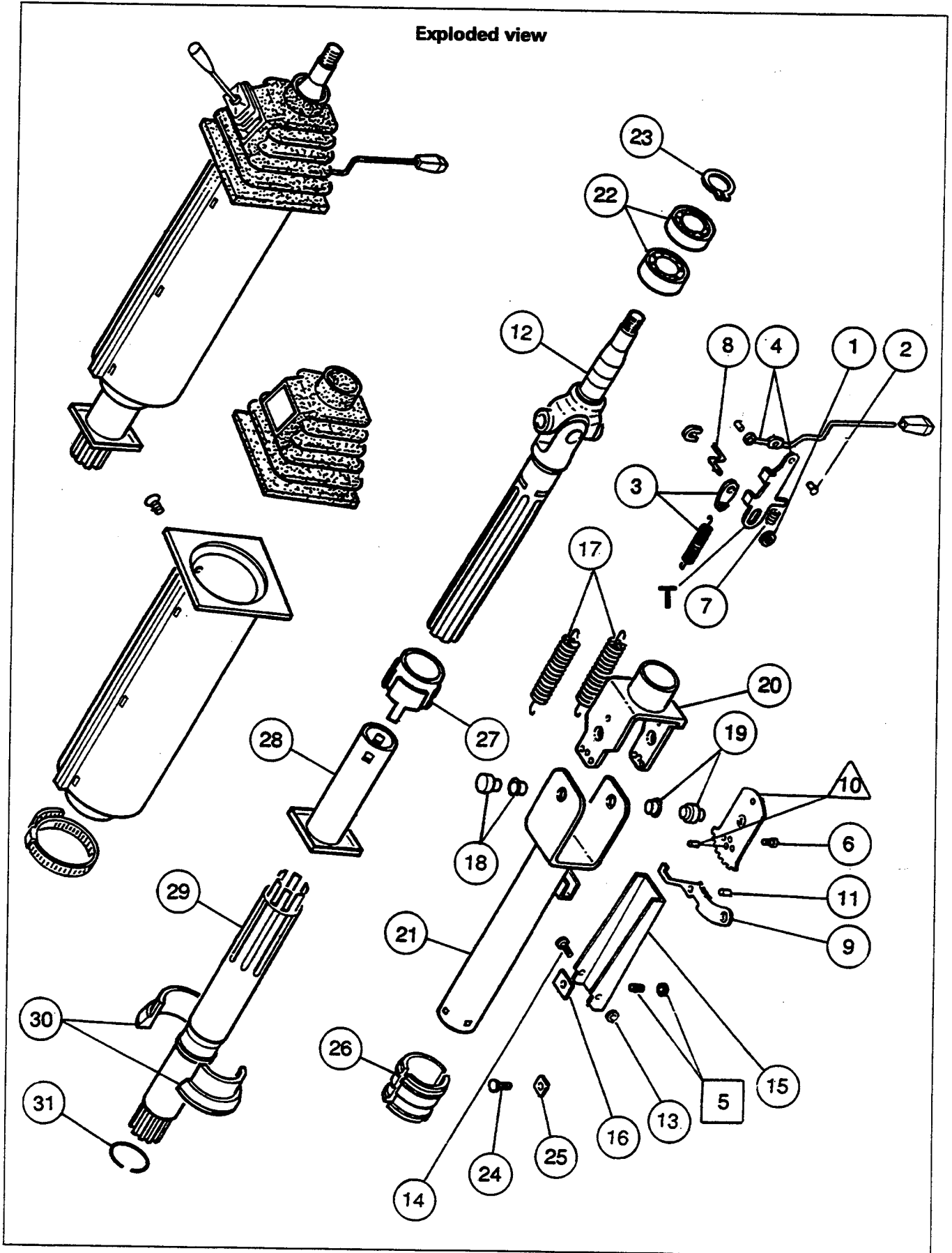



## Front axle - Steering column

8E01.5

### A. Removing and refitting the steering column

#### Removal

1. Using the lever on the right-hand side under the steering wheel, pull the steering column as far towards the driver as possible.
2. Remove the steering wheel, the upper dashboard covering and the lower protector.
3. Disconnect the control switches (1) located under the dashboard (Fig. 1) and remove the hazard warning light support.
4. Take out the bolts (2) attaching the base of the column onto the cab support (Fig. 1).
5. Remove the assembly.

#### Refitting

6. Check the operation of all the positions of the steering column.
7. Lightly coat the splines in shaft (29) with «Anti-Seize» grease or equivalent.
8. Carry out procedures 2 to 5 in reverse order.  
**Note: Tighten the steering wheel nut to a torque of 57 - 78 Nm.**
9. Check the operation of the electrical equipment and the A, B, C, D ratios (for Dynashift) or both ranges for Speedshift.

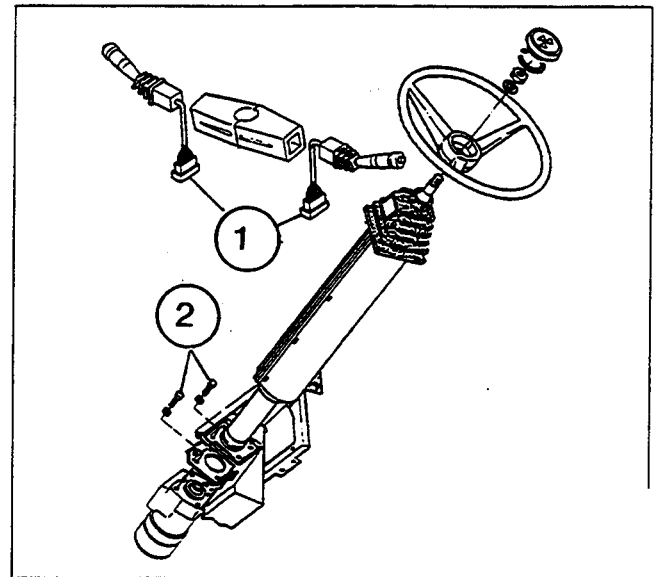

### B. Disassembling and reassembling the control lever assembly

#### Disassembly

10. Remove the steering column. Carry out procedures 1 to 5.
11. Remove the housing in two halves around the steering column. Remove the Dynashift or Speedshift control (depending on the version) and the lighting switch.
12. Remove and discard the retaining washers (1) and (2). Remove the spring (3), lever (4) with the dust cover and lever (8).

#### Reassembly

13. Refit the levers (4) and (8) and the spring (3). Replace the retaining washers (1) and (2).
14. Adjust the lever (4), rod T in contact with the notched lever (9) using the adjusting screw [5] (3 mm Allen wrench).
15. Carry out procedure 11 in reverse and carry out procedures 6 to 9.

### C. Removing and refitting the notched lever and rack

#### Removal

16. Remove the steering column. Carry out procedures 1 to 5.
17. Remove the housing in two halves around the steering column. Remove the Dynashift or Speedshift control (depending on the version) and the lighting switch.
18. Remove and discard the retaining washers (1) and (2). Remove the spring (3), lever (4) with the dust cover.
19. Compress spring (7) by pressing on the notched lever (9). Take out the bolts (6). Remove the rack /10\.
20. Drive out pin (11). Remove the notched lever (9) and spring (7).



8E01.6

## Front axle - Steering column

### Refitting

21. Carry out procedure 20 in reverse.
22. Compress spring (7). Position the rack /10\ as per Fig. 2 to avoid any interference with lever (4). Fit and tighten bolts (6) after coating them with Loctite 241.
23. Refit the lever (4), rod T and spring (3). Replace the retaining washers (1) and (2).
24. Adjust the lever (4), with rod T in contact with the notched lever (9), using the adjusting screw [5] (3 mm Allen wrench).
25. Carry out procedure 17 in reverse and carry out procedures 6 to 9.

### D. Disassembling and reassembling the locking assembly

#### Disassembly

26. Remove the steering column. Carry out procedures 1 to 5.
27. Remove the housing in two halves around the steering column.
28. Remove the adjusting screw [5] (3 mm Allen wrench). Remove and discard the retaining washer (13). Drive out the pin (14).
29. Remove the arm (15) and lock plate (16).

#### Reassembly

30. Carry out procedure 29 in reverse.
31. Fit the pin (14). Replace the retaining washer (13).
32. Fit and set the adjusting screw [5] and lever (4) with rod T in contact with the notched lever (9).
33. Carry out procedure 27 in reverse and carry out procedures 6 to 9.

### E. Replacing the shafts and bearings

#### Disassembly

34. Remove the steering column. Carry out procedures 1 to 5.
35. Remove the housing in two halves around the steering column. Remove the Dynashift or Speedshift control (depending on the version) and the lighting switch.
36. Slide the dust cover over the control lever (4).
37. Compress spring (7) by pressing on the notched lever (9). Remove the bolts (6). Remove the rack /10\.
38. Remove the springs (17).

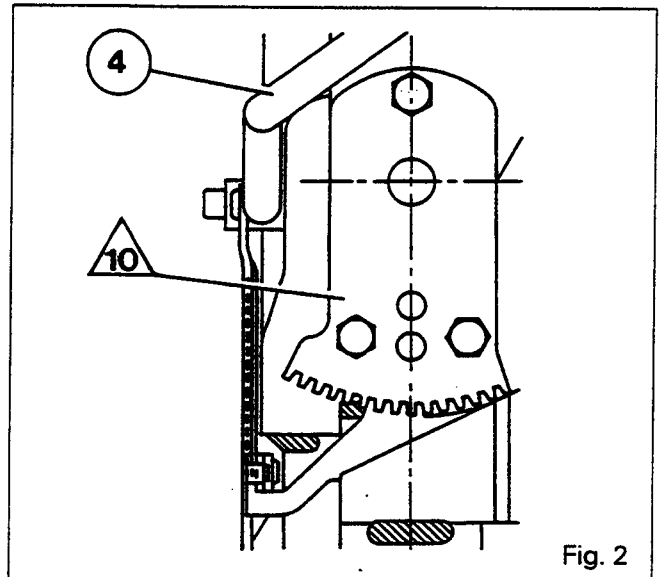

39. Uncrimp pin (18). Drive out pins (18) and (19).
40. Separate the housing (20) from the moving column (21).
41. Remove the circlip (23). Separate the upper shaft (12) from the housing (20).
42. Drive out the lower shaft (29) from the moving column (21).
43. Extract the bearings (22) from the housing (20).

#### Reassembly

44. Fit the bearings (22) in the housing (20) using a suitable fixture.
45. Assemble the upper shaft (12) on the bearings (22). Fit the circlip (23).
46. Assemble the lower shaft (29) equipped with bushes (30) and circlip (31) on the fixed column (28). **Note: Deform the column tube by striking it with a punch so as to lock the bushes (30) in position.**
47. Reassemble the housing (20) and mobile column (21) assemblies. Fit pins (18) and (19). Crimp pin (18).
48. Refit the springs (17).
49. Compress spring (7). Position the rack /10\ as per Fig. 2 to avoid any interference with lever (4). Fit and tighten the bolts (6) after coating them with Loctite 241.
50. Adjust the lever (4), rod T in contact with the notched lever (9) using the adjusting screw [5] (3 mm Allen wrench).
51. Carry out procedure 35 in reverse and carry out procedures 6 to 9.



## Front axle - Steering column

### F. Replacing the guide bushes (26) (27) (30)

#### Disassembly

52. Remove the steering column. Carry out procedures 1 to 5.
53. Remove the housing in two halves around the steering column.
54. Loosen the adjusting screw [5] (3 mm Allen wrench). Remove the lock plate (16).
55. Remove the bolt (24) from the stop (25).
56. Extract the bush (26).
57. Separate the moving column (21) from the fixed column (28).
58. Extract the bush (27).

#### Reassembly

59. Position bush (27).
60. Place the stop (25) in the groove on the fixed column (28).
61. Assemble the mobile column (21) with the fixed column (28).
62. Fit the bolt (24) without tightening it so that bush (26) can be installed. After installing the bush, tighten the bolt moderately. Check that the moving column (21) slides freely.
63. Refit the lock plate (16). Adjust the lever (4), rod T in contact with the notched lever (9) using the adjusting screw [5].
64. Carry out procedure 53 in reverse and carry out procedures 6 to 9.





**Front axle - Bearings**

8F01.1

8 F01 Bearings

CONTENT

-	<b>General</b> _____	<b>2</b>
A.	<b>Removing and refitting the bearings</b> _____	<b>2</b>
B.	<b>Replacing the bushes and seal</b> _____	<b>4</b>
C.	<b>Identification of supports and tightening torques</b> _____	<b>5</b>



8F01.2

## 6100 SERIES TRACTORS

**Front axle - Bearings****General**

The lower section of the front frame of 6110 to 6150 series tractors supports the second swivel pin of the front axle assembly. The first pivot is articulated on a removable bearing. On tractors in series 6160 to 6190, the front and rear bearings are removable.

**Special points (6190)**

Rear attachment of the AG 155 axle assembly is provided by a bearing (6) (Fig. 3) that is different from the one fitted on tractors 6160 to 6180. The lower section of the frame is specially moulded to allow the installation of the bearing, attached by bolts (12) and (13).

The steering ram supply unions are oriented downwards to avoid any interference with the frame.

**A. Removing and refitting the bearings****Removal**

1. Immobilise the rear wheels with chocks and apply the handbrake.
2. Disconnect the two hoses supplying the front differential lock. Remove the guard and the drive shaft.
3. Lift the tractor with a jack placed along the centreline of the axle housing. Position a stand under the crankcase (Fig. 1). Remove the wheels.
4. Disconnect the hoses supplying the steering ram, and mark their positions.
5. Hoist the front axle with strap slings (Fig. 1).
6. Remove the grease nipple (3) and the bolts (1). Remove the bearing (2) (Fig. 2), the washer (4) and the seal (9).
7. Remove the bolts (12) and (13) (Fig. 3). Remove the front axle with the bearing (6).
8. Dismount the bearing from the front axle. Remove the washer (7) and the dust guard (8).

**Refitting**

9. Replace the dust guard (8). Position the washer (7) with the chamfer facing the axle housing (52). Assemble the bearings (6) on the front axle.
10. Hoist the front axle with slings. Fit the front axle assembly and the bearing. Fit the bolts (12) and (13).

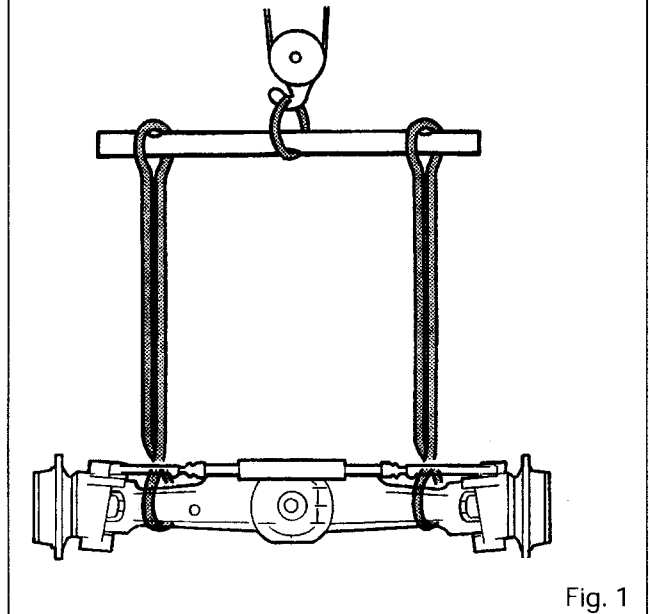
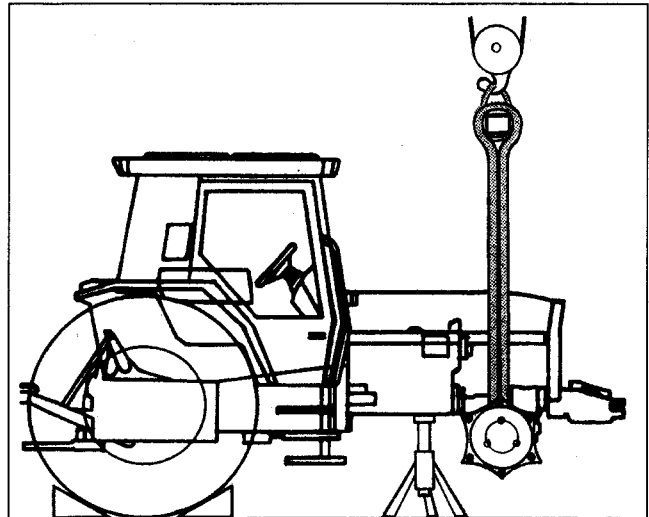

Fig. 1

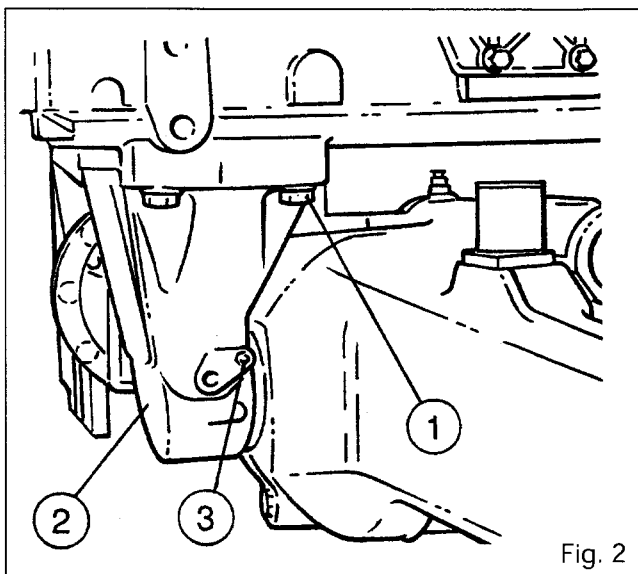

Fig. 2

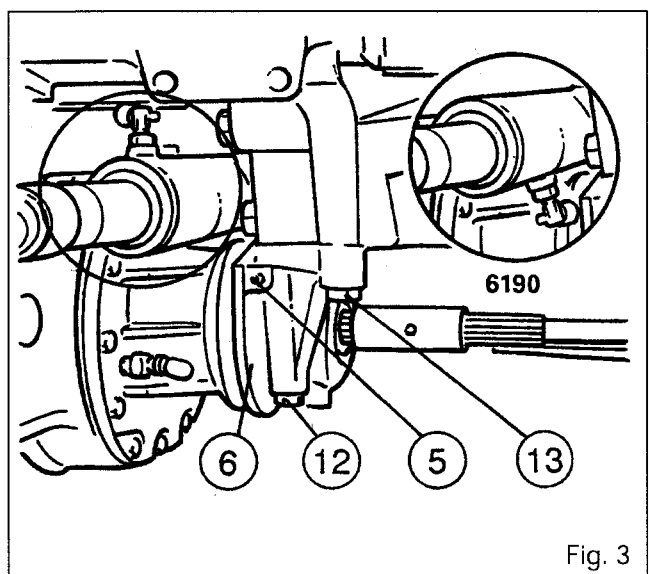

Fig. 3



**Front axle - Bearings**

8F01.3

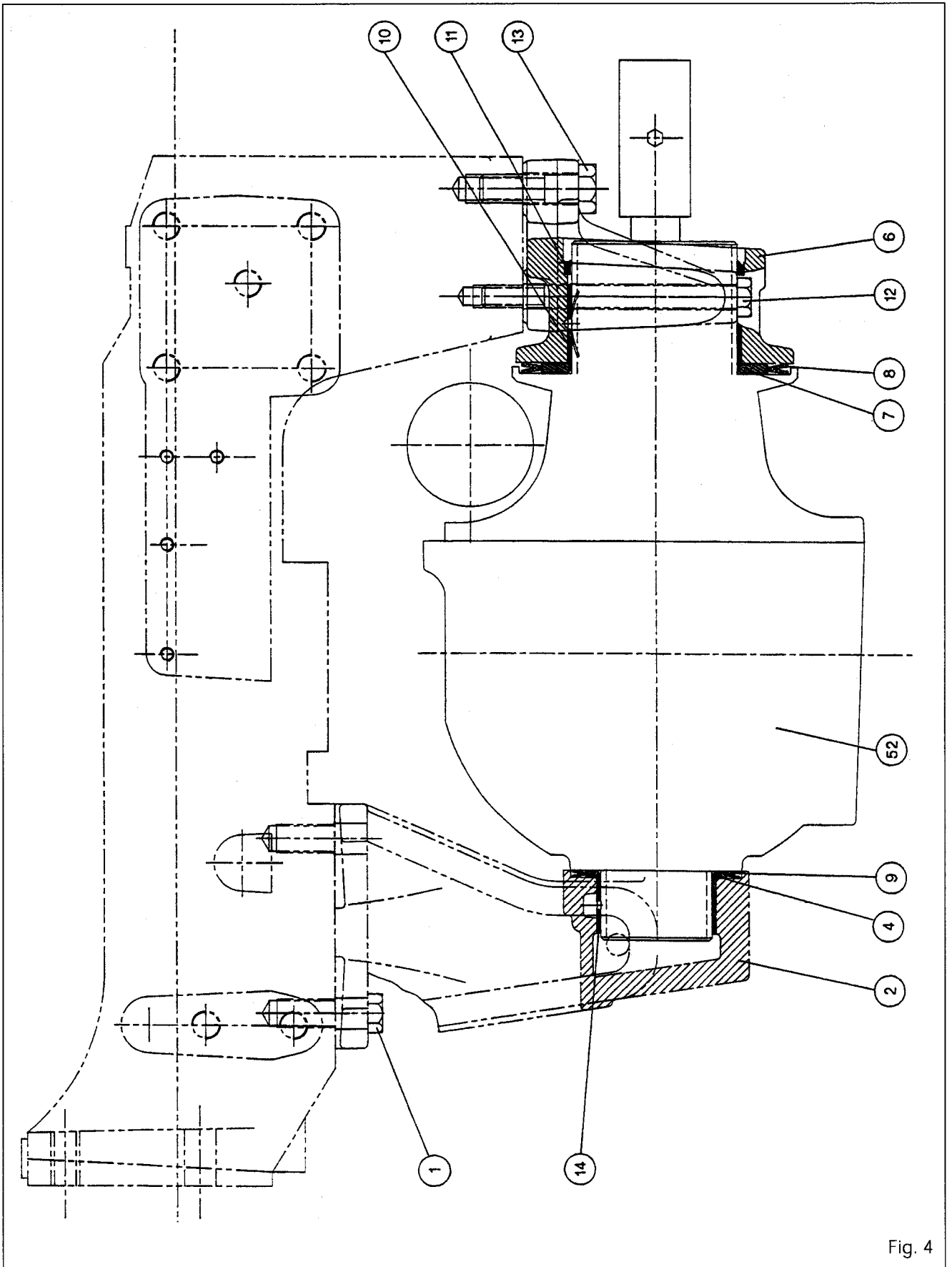

Fig. 4





8F01.4

## Front axle - Bearings

11. Replace the dust guard (9). Position the washer (4) with the chamfer facing the axle housing (52). Fit the bearing (2). Fit the bolts (1).
12. Smear the bolts (12) and (13) with Loctite 270. Tightening torque:
  - (12) : 240 to 320 Nm
  - (13) : 520 to 640 Nm.
13. Press the bearing (2) onto the washer (4) so as to take up as much play as possible. Smear the bolts (1) with Loctite 270 and tighten them to a torque of 520 to 640 Nm.
14. Fit the grease nipples on the bearings (2) and (6).
15. Connect up the hoses for the steering ram. Smear the two drive shaft sleeves with "Anti-Seize" grease or equivalent. Reinstall the transmission shaft and the guard. Connect up the two hoses for the front differential lock. Fit the wheels and tighten to the following torques:
  - axles AG 85 - AG 105: 400 to 450 Nm,
  - axle AG 125: 800 to 850 Nm. From serial number D152010 onwards: tighten to a torque of between 640 and 680 Nm.
16. Using a pump, grease the bushes (10) and (14).

### B. Replacing the bushes (10) and (14) and the seal (11)

#### Removal

17. Extract the seal and the worn bushes.

#### Refitting

18. Clean the parts, using a press and a suitable fixture, fit the bushes in their respective supports flush with face "F" (Fig. 5) with opening "O" facing upwards (Figures 6 and 7) and aligned with the lubricating channel. Fit the seal (11) fully home on the shoulder of the support (6).

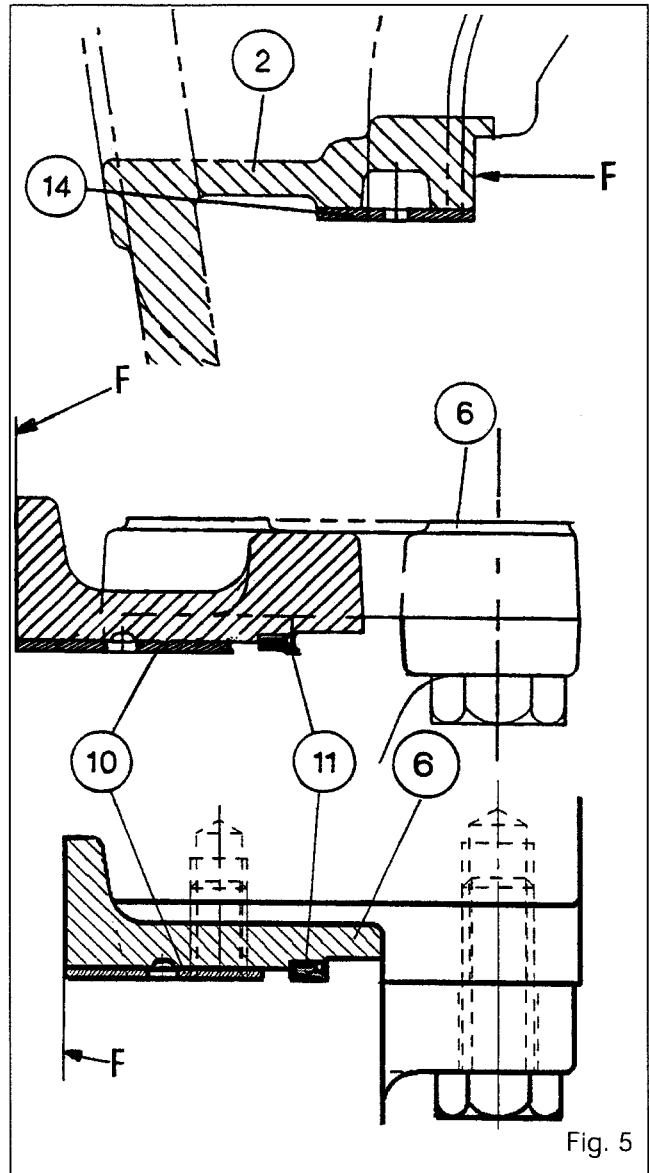

Fig. 5

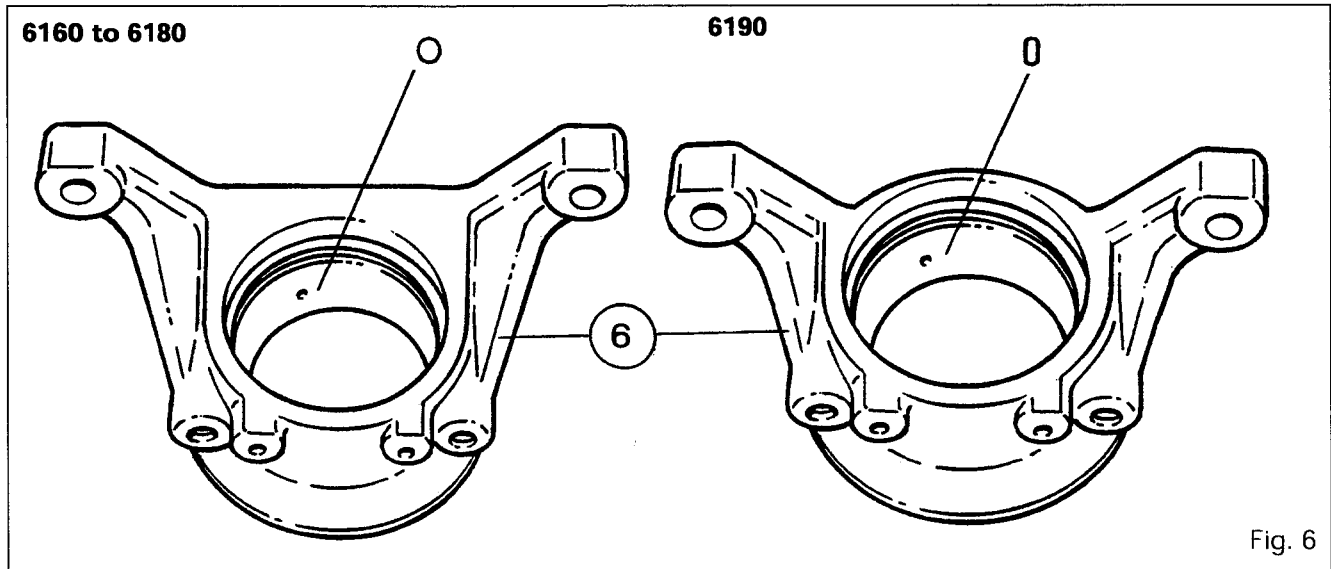

Fig. 6



## Front axle - Bearings

### C . Identification of supports and tightening torques

#### Front support

##### Tractors in series 6110 to 6190

A : Support with dust guard (9) (Fig. 8).

B : Support for PTO with dust guard (9) (Fig. 9).

#### Rear support

##### tractors in series 6110 to 6150

C : Installation with quadring seal (15) and seal (11) (Fig. 10) (lower section of front frame used as support).

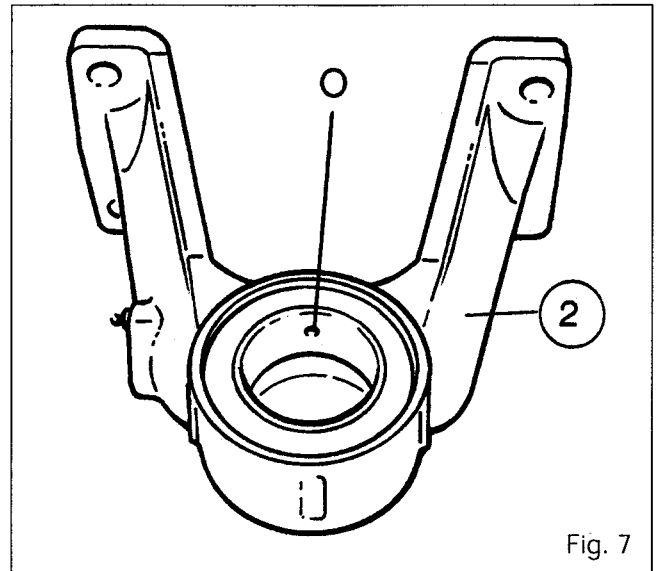

Fig. 7

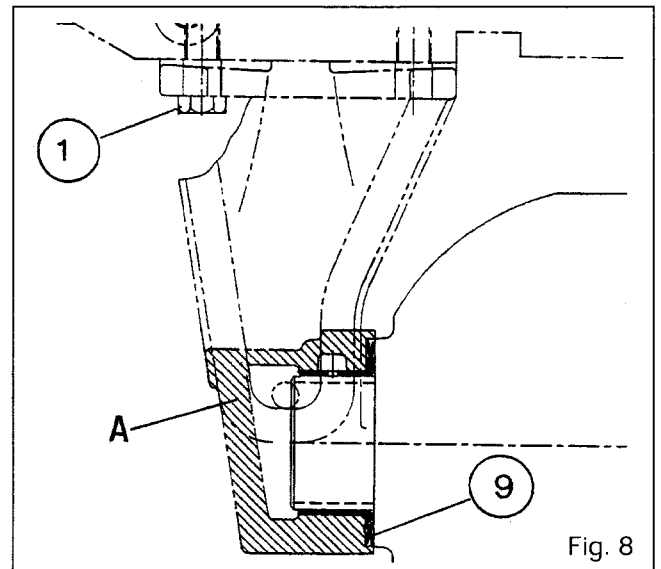

Fig. 8

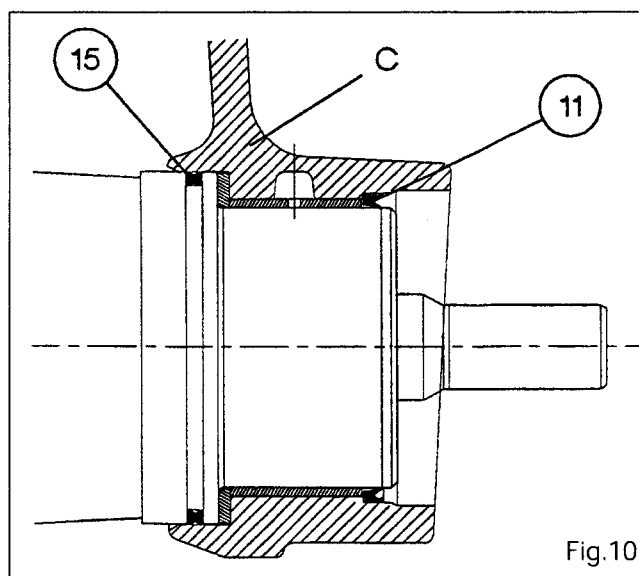

Fig.10

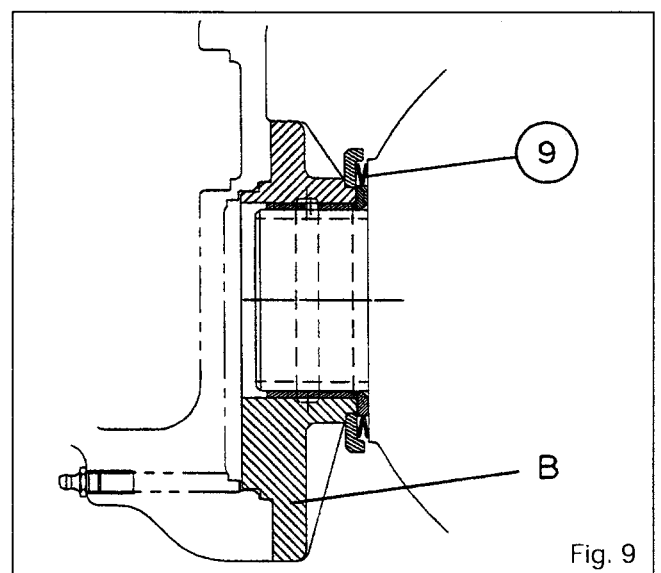

Fig. 9



8F01.6

# Front axle - Bearings

### Tractors in series 6160

D : Installation with quadring seal (15) and seal (11) (Fig. 11) (removable support).

### Tractors in series 6170 and 6180

E : Installation with dust guard (8) and seal (11) (Fig. 11) (removable support).

### Tractors in series 6190

F : Installation with dust guard (8) and seal (11) (Fig. 12) (removable support).

### Tightening torques

Coated with Loctite 270:

- bolts (1) and (13): 520 to 640 Nm
- bolts (12) 240 to 320 Nm

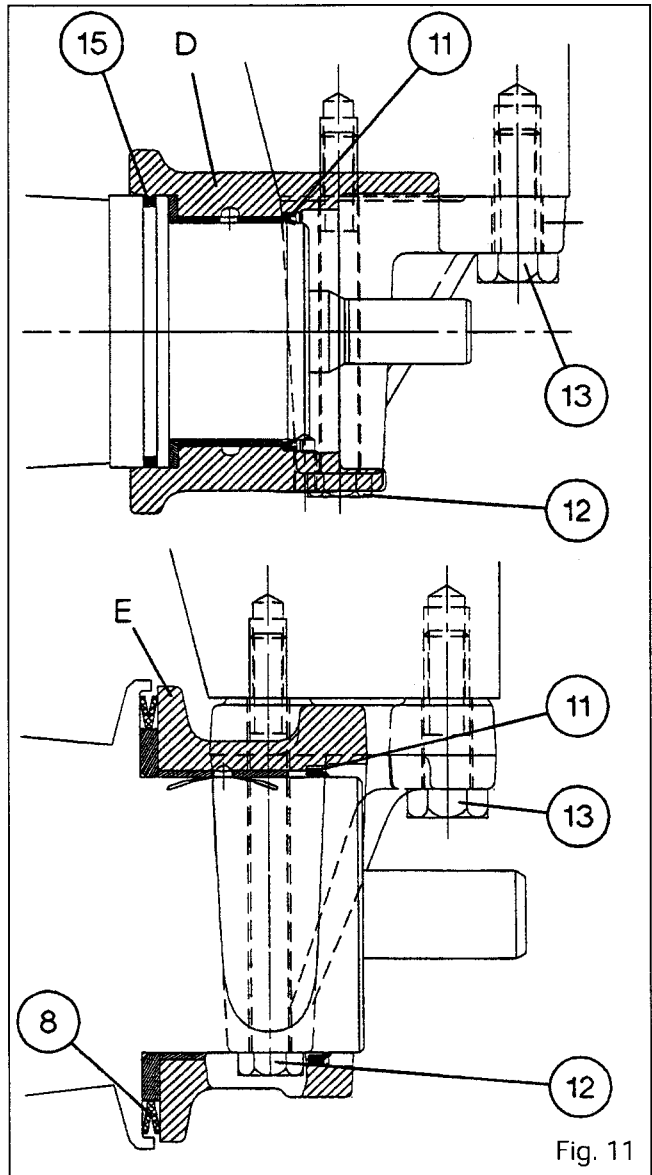

Fig. 11

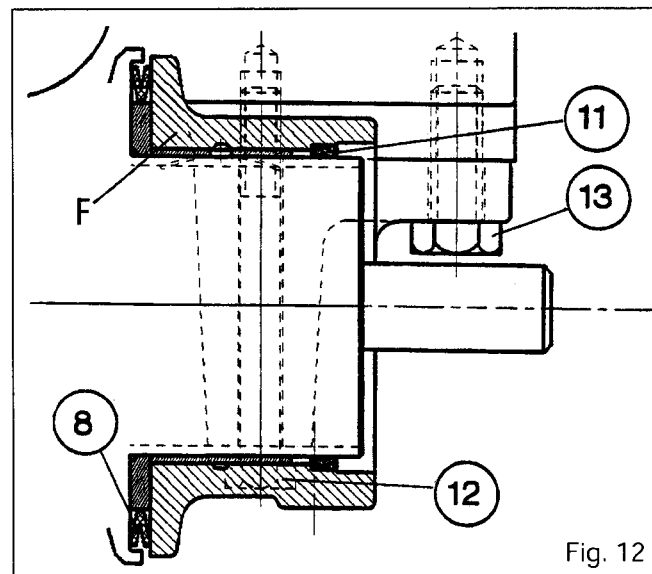

Fig. 12



# 9 . HYDRAULICS

## Contents

### OPEN CENTRE

- 9 A01 DESCRIPTION OF CIRCUIT
- 9 B01 TRAILER BRAKING
- 9 C01 AUXILIARY SPOOL VALVES
- 9 D01 LIFT CONTROL VALVE
- 9 E01 HYDROSTATIC STEERING
- 9 F01 LOW-PRESSURE COMPONENTS
- 9 G01 BRAKE AND CLUTCH MASTER  
CYLINDER CIRCUIT
- 9 H01 DISTRIBUTION VALVE
- 9 I01 RIGHT HAND HYDRAULIC COVER
- 9 I02 LEFT HAND HYDRAULIC COVER
- 9 J01 CLUTCH CONTROL VALVE
- 9 K01 DYNASHIFT CONTROL
- 9 L01 HYDRAULIC TESTS

### CLOSED CENTRE

- 9 F01 LOW-PRESSURE COMPONENTS
- 9 J01 CLUTCH CONTROL VALVE
- 9 K01 DYNASHIFT CONTROL
- 9 M01 DESCRIPTION OF CIRCUIT
- 9 N01 TRAILER BRAKE
- 9 P01 DISTRIBUTION BLOCK
- 9 Q01 AUXILIARY SPOOL VALVES
- 9 R01 LIFT CONTROL VALVE
- 9 S01 HYDROSTATIC STEERING
- 9 T01 RIGHT-HAND COVER
- 9 T02 LEFT-HAND COVER
- 9 U01 BRAKE AND CLUTCH MASTER  
CYLINDERS CIRCUIT
- 9 V01 TESTS





**Hydraulics - Description of circuit**

*9 A01 Description of circuit*

CONTENTS

**A. General circuit** \_\_\_\_\_ 2

**B. Low-pressure circuit, low flow** \_\_\_\_\_ 2

**C. High-pressure circuit, high flow** \_\_\_\_\_ 2

**D. Description, layout of parts** \_\_\_\_\_ 3

**E. Circuit diagrams** \_\_\_\_\_ 5



9A01.2

## 6100 SERIES TRACTORS



# Hydraulics - Description of circuit

### A. General circuit

The hydraulic system of the 6100 tractors is of the open centre type. It is divided into two separate circuits fed by a two-stage gear pump, fitted on the internal face of the right cover. Via a 150 micron strainer also fitted on the right cover, the pump uses the transmission oil contained in the common reservoir formed by the centre housing and the gearbox. A 15 micron pressure filter (40) and a clogging indicator (44) fitted on the low flow circuit before the Orbitrol steering unit. The hydraulic pump is driven by the teeth of the PTO clutch housing.

The functions supplied by the low-pressure circuit are as follows:

- . The hydrostatic steering
- . The hi/lo (Hare/Tortoise) range
- . The differential lock (front and rear)
- . The 4WD clutch
- . The Speedshift or Dynashift (according to version)
- . The electro-hydraulic control of the reverse shuttle
- . The PTO circuits:
  - clutch
  - PTO brake
  - Front PTO (option)

### B. Low-pressure circuit, low flow

This circuit gives priority to supplying the hydrostatic steering system where the pressure can reach 170 bar. After satisfying the needs of the steering valve (Orbitrol), the oil is sent to a distribution valve fixed under the hood. This valve has a number of functions:

#### - Pressure maintaining valve

Downstream of the Orbitrol, the distribution valve maintains the operating pressure of the various transmission elements at 17 bar.

#### - Cooling, lubrication and clutch and brake master cylinder supply circuit

After supplying the various transmission elements, the distribution valve sends the oil to the oil cooler if it is hot, or directly to the gearbox and PTO lubrication system if it is cold. The lubrication pressure is maintained by a valve set at 1.5 bar, fitted on the front left of the gearbox. The residual flow from the distribution valve also supplies the clutch and brake master cylinders.

#### Functions supplied by the low flow circuit

The 17 bar circuit supplies the various transmission functions in parallel, via solenoid valves screwed depending on the version, on the Dynashift control, on the gearbox housing, on the selector cover and into the main gallery of the right cover.

None of these are priority functions and they can be actuated simultaneously.

Certain of the solenoid valves (4WD, PTO and electro-hydraulic control of the reverse shuttle (if fitted)) are connected to the Autotronic device.

### C. High-pressure circuit, high flow

The second stage of the pump supplies, in this sequence:

- The trailer brake valve, which has priority
- The auxiliary spool valves
- The lift control valve (rear linkage)

The oil not used by the trailer brake valve supplies the auxiliary spool valves fitted on the rear of the lift cover. Exiting from the auxiliary spool valves, a hose supplies the lift valve situated on the left side cover.

The excess flow from these three spool valves returns to the pump intake manifold without passing through the strainer. A safety valve fitted in the delivery pipe of the right hand cover protects the high-pressure circuit.

**Hydraulics - Description of circuit****D. Description, layout of parts****6170 to 6190 tractors**

Pressure loaded clutch with Dynashift and selector cover with electro-hydraulic reverse shuttle (if fitted).

**Parts list**

- (1) Front differential lock
- (2) Steering ram
- (3) 17 bar distribution valve
- (4) Hydrostatic steering unit (Orbitrol)
- (5) Speedshift
- (6) Dynashift
- (7) Hare/Tortoise range
- (8) PTO clutch
- (9) 4WD clutch
- (10) Rear differential lock
- (11) PTO brake
- (12) Front PTO (if fitted)
- (13) Oil cooler
- (14) Clutch master cylinder
- (15) Brake master cylinders
- (18) Hare/Tortoise solenoid valve
- (19) Differential lock solenoid valve
- (20) PTO solenoid valve
- (21) PTO brake solenoid valve
- (22) 4WD solenoid valve
- (23) Front PTO solenoid valve (option)
- (24) Low-pressure switch
- (25) RH and LH brake
- (26) Pump inlet pipe
- (27) 150 micron suction strainer
- (28) Filter vacuum switch
- (29) Hydraulic pump
- (30) Safety valve
- (31) Trailer brake valve
- (32) Trailer brake connector
- (33) Auxiliary spool valves
- (34) Lift valve
- (35) Lift rams
- (36) 1.5 bar valve
- (37) Diagnostic connector
- (38) Piston of electrohydraulic reverse shuttle (if fitted)
- (39) Lubrication: Speedshift or Dynashift (according to version) - reverse shuttle - gearbox, PTO
- (40) 15 micron pressure filter
- (41) Clutch valve hydraulic control
- (42) Accumulator
- (43) Electrohydraulic reverse shuttle solenoids (if fitted)
- (44) Clogging indicator
- (47) Clutch-Pressure loaded
- (48) Check valve, 5 bar
- (49) Lubrication of brakes

- High pressure
- Excess flow
- Low pressure
- Lubrication
- Suction
- Return
- Brakes - Clutch
- Pilot flow

On Speedshift tractors a plug is fitted instead of the tube "T" and one solenoid (45) is suppressed.

**Clogging indicator (44) screwed on top of filter (40)**

Actuation pressure :  $2.4 \pm 0.3$  bar

Reset pressure :  $1.8 \pm 0.3$  bar

Connected to the dashboard

Tightening torque : 50 - 60 Nm

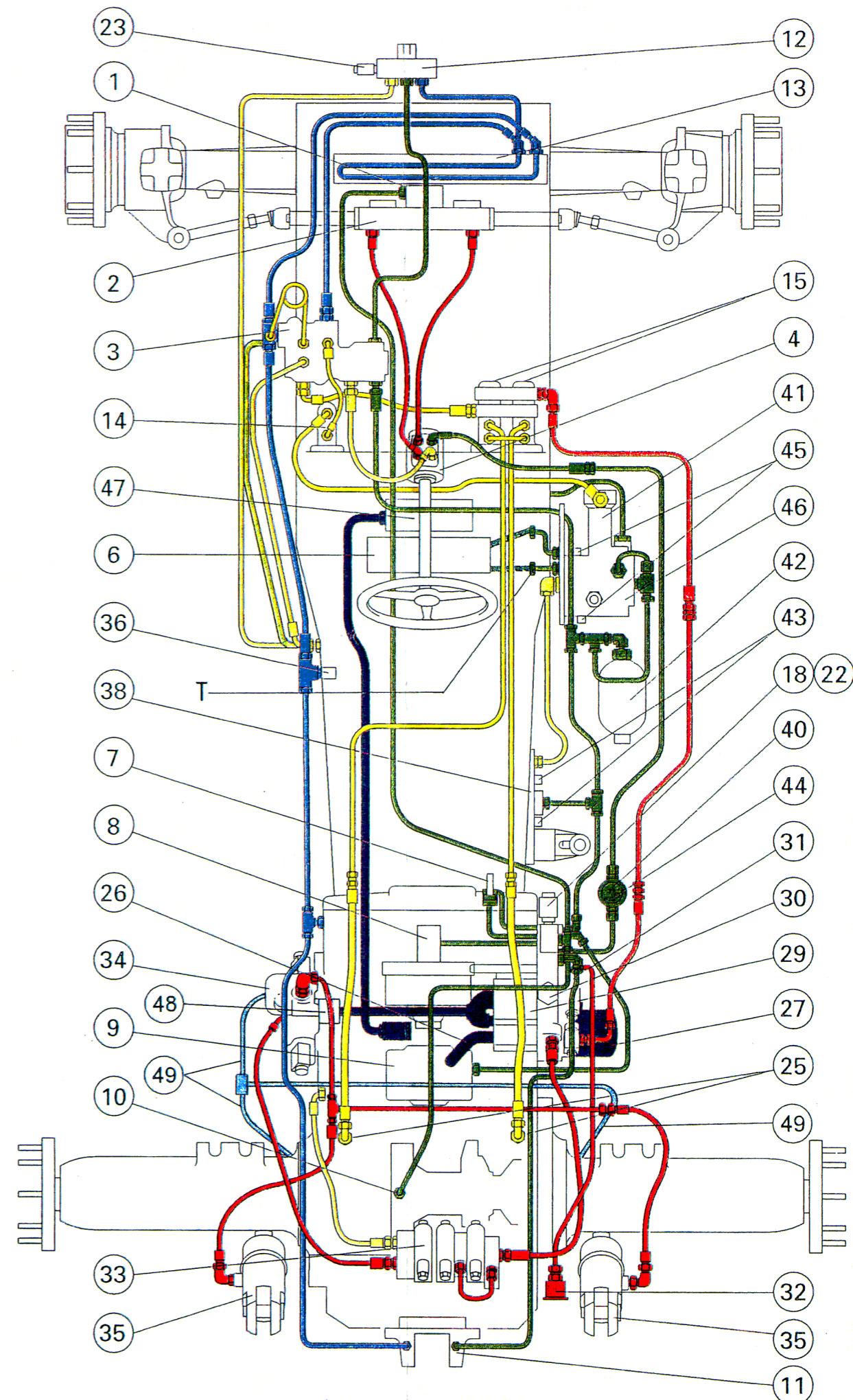





9A01.4

# Hydraulics - Description of circuit

Layout of parts  
6110 to 6160 tractors

Spring loaded clutch with Speedshift

- (5) Speedshift
- (16) Spring loaded clutch
- (17) Speedshift solenoid
- (45) Dynashift solenoid
- (46) Dynashift control valve

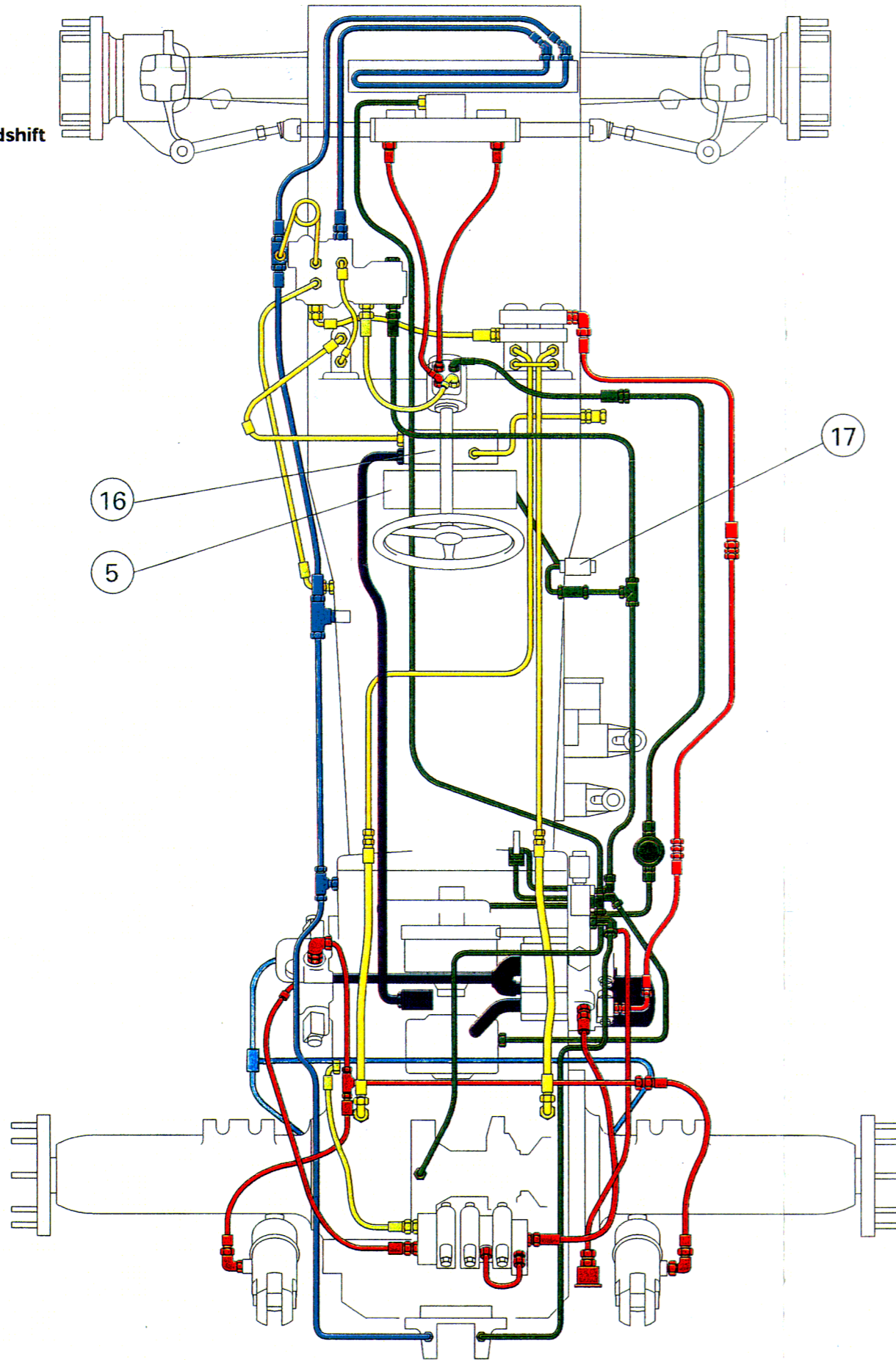

Spring loaded clutch with Dynashift and electro-hydraulic reverse shuttle selector cover

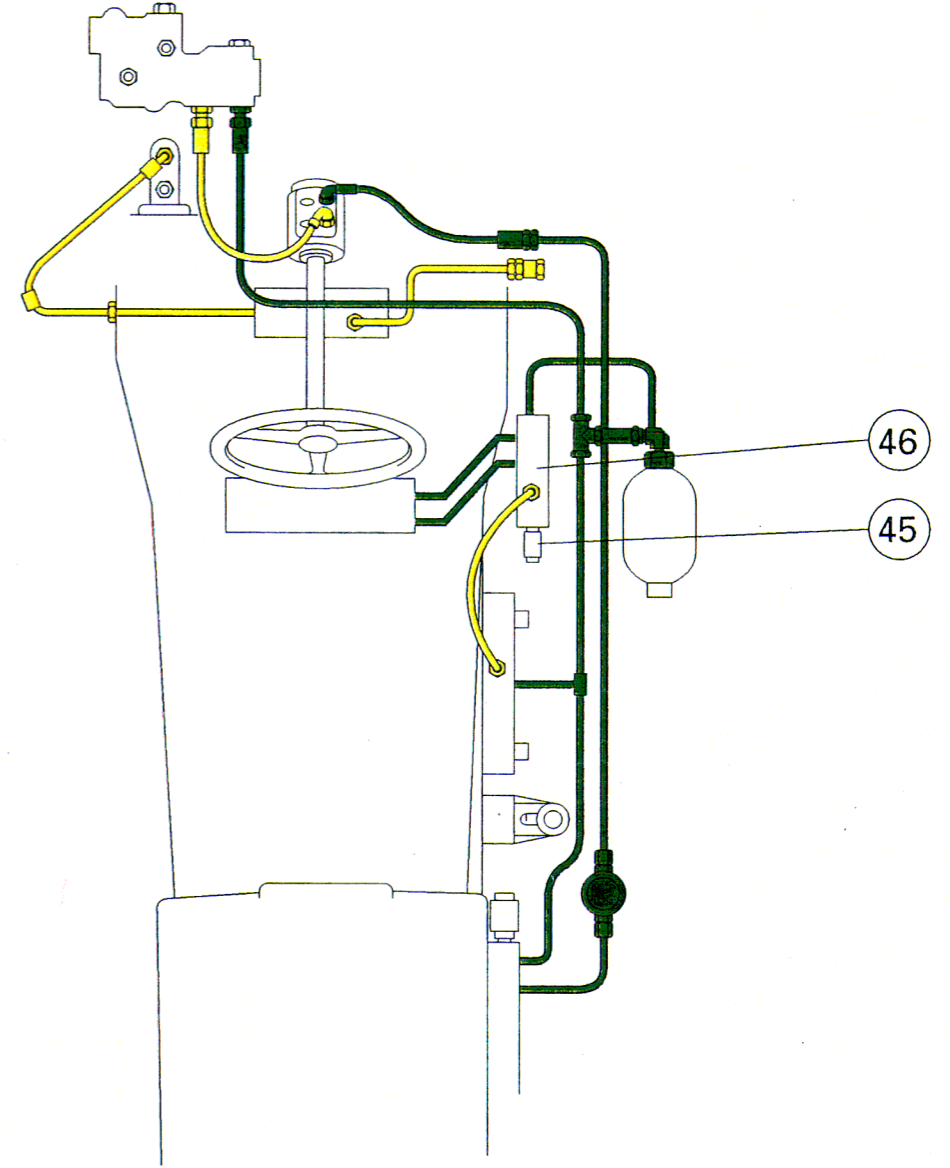



# Hydraulics - Description of circuit

## E . Circuit diagrams

### 1 . ISO diagram

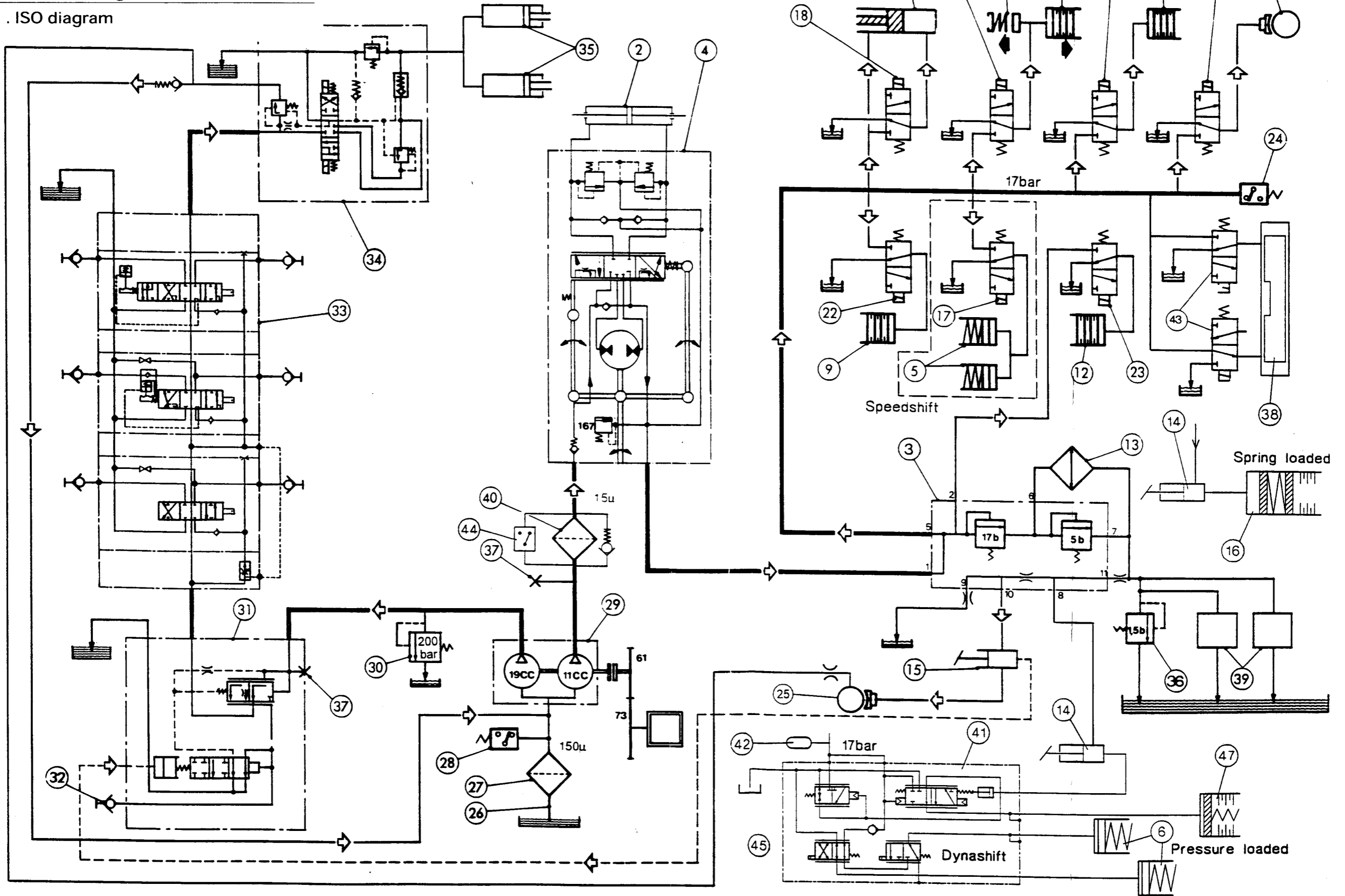



9A01.6

6100 SERIES TRACTORS



# Hydraulics - Description of circuit

## 2. Simplified diagram

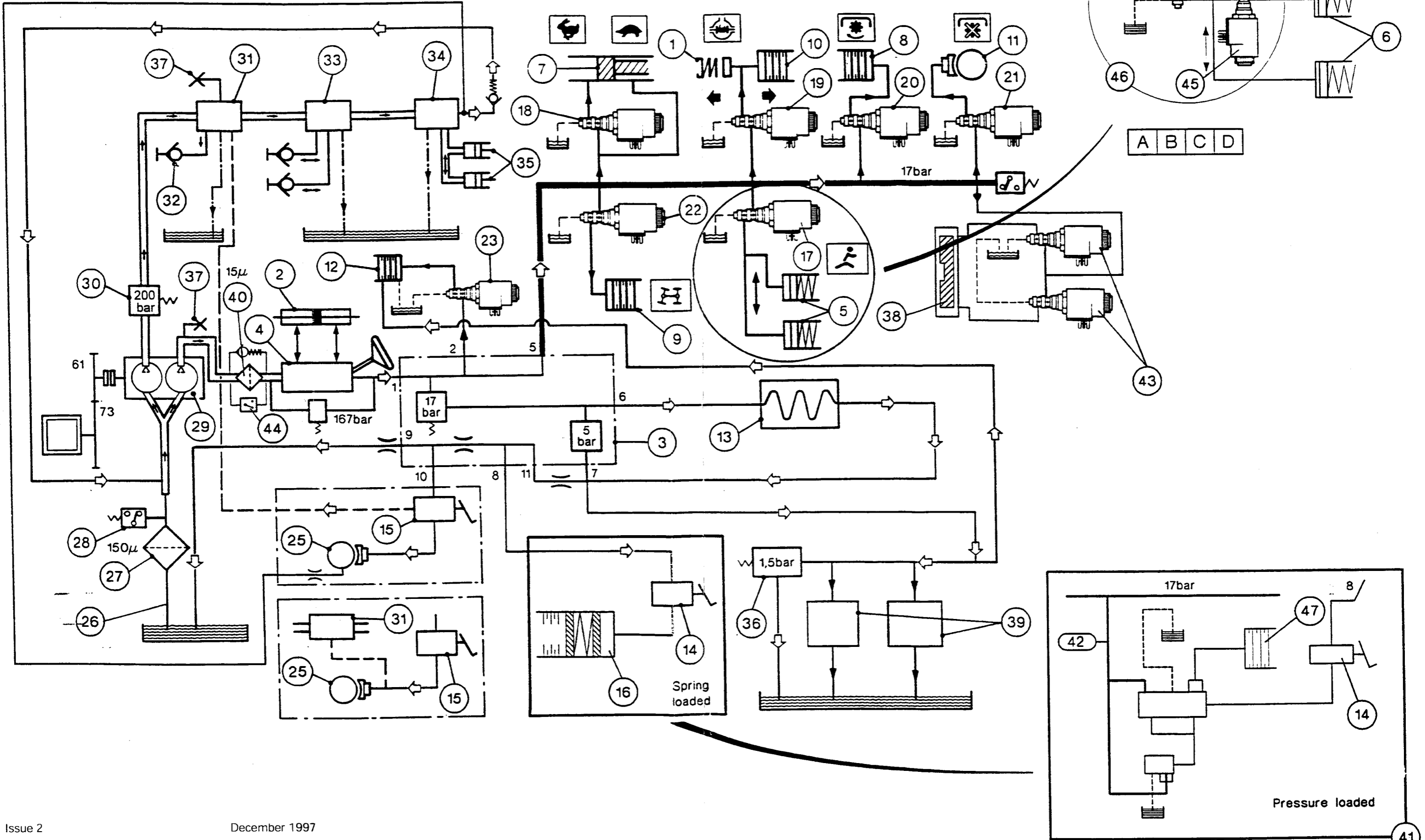



**Hydraulics - Trailer braking**

9 B01 Trailer braking

CONTENTS

-	<b>General</b> _____	<b>2</b>
A.	<b>Removal and refitting of trailer brake valve</b> _____	<b>3</b>
B.	<b>Operation, trailer brakes released and partial trailer braking</b> __	<b>5</b>
C.	<b>Partial braking and maximum braking of the trailer</b> _____	<b>7</b>



9B01.2

## 6100 SERIES TRACTORS

**Hydraulics - Trailer braking****General**

6100 tractors can be equipped with a trailer braking system consisting of :

- A valve assembly (spool valve) fitted on the right-hand hydraulic cover.
- A pipe linking the trailer braking valve to a connector situated at the rear of the tractor.
- A pipe connected to the master cylinders or to a supply hose of the main right-hand brake (depending on version) linked to the pilot head of the valve.

The valve is supplied as a matter of priority by the high-pressure circuit. The oil not used for the braking of the trailer is sent to the auxiliary spool valves.

The valve controls the flow and pressure towards the trailer brakes. It is controlled by the pressure of the tractor braking circuit so as to obtain tractor/trailer braking that is progressive and proportional to the effort applied to the pedal. The trailer brake only works if the two pedals are coupled.

**Description of the trailer braking valve (Fig. 1)****Flow control valve (1)**

Provides control of the flow  $Q_x$  and regulation of the hydraulic flow, transmitting the pressure to the trailer-brakes (see pages 4 and 6).

**Control spool assembly(2)**

Changes the position of the flow control valve and regulates the trailer braking pressure.

**Check valve(3)**

Prevents oil flowing back from brake line B to port N (see pages 4 and 6).

**Pressure relief valve (4)**

with loaded springs (8)

Limits the maximum brake pressure.

**Pilot flow housing (5)**

with piston (6) and bleed screw (7)

Operates the trailer brake valve via a sensing line from the tractor brakes.

**Designation of ports (see pages 4 and 6)**

**B** Supply to the trailer brake connection (junction)

**N** Continuation to the auxiliary spool valve

**P** Pressure

**R** Return to sump

**Y** Supply coming from the tractor braking system

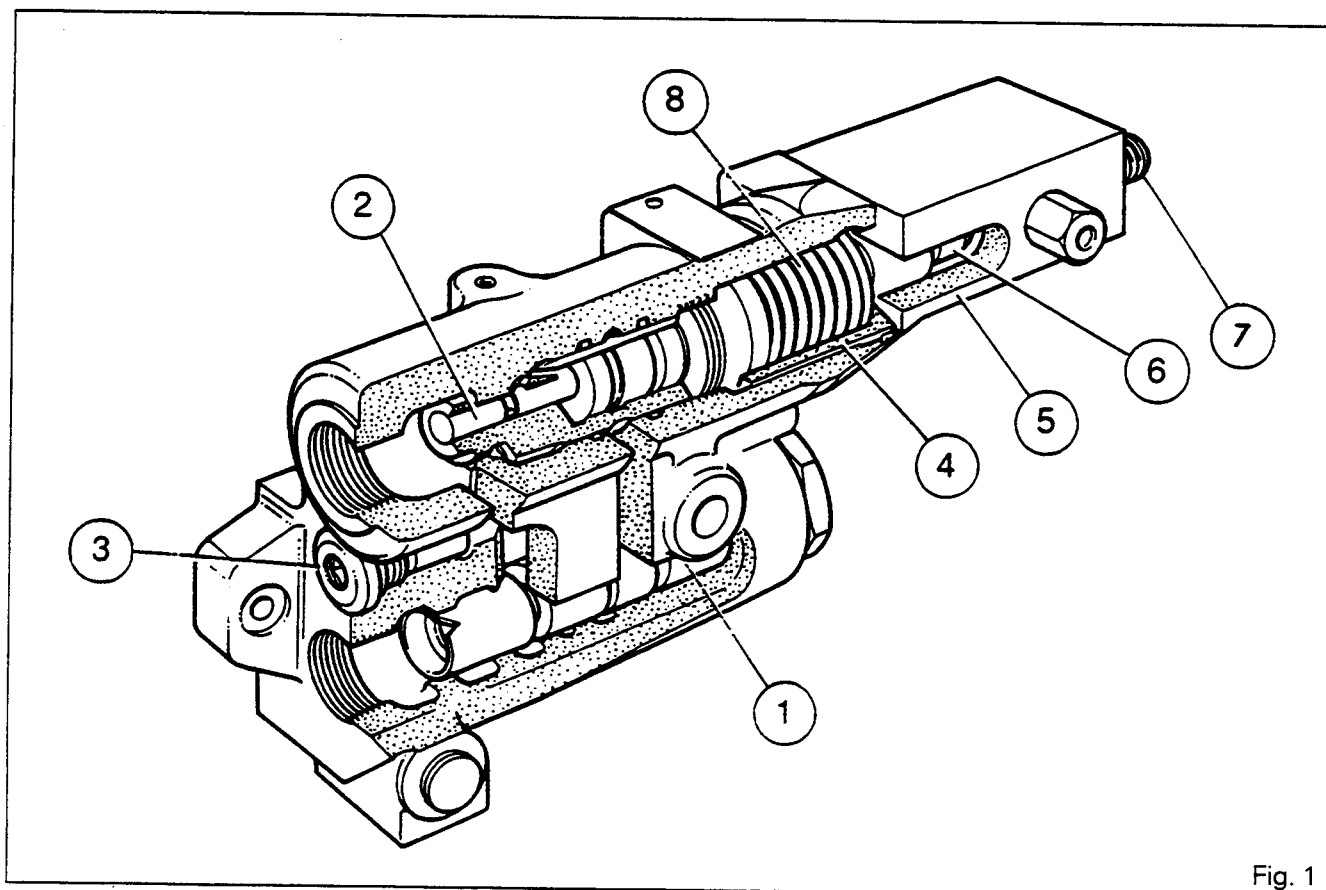

Fig. 1



## Hydraulics - Trailer braking

### A. Removal and refitting of trailer brake valve

#### Removal (Fig. 2)

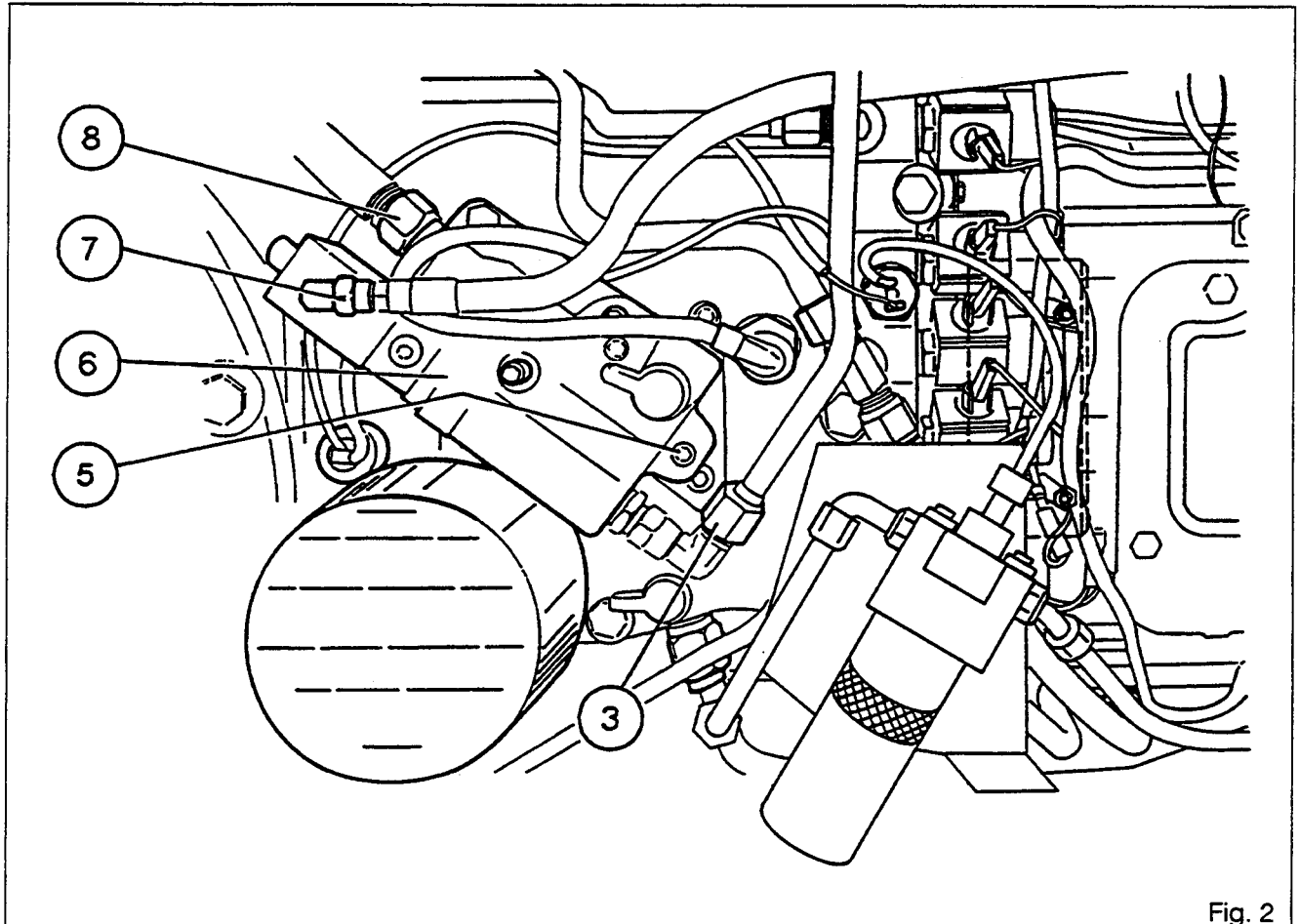

Fig. 2

#### 1. Disconnect and block:

- the hose (7) of the pilot housing,
- the supply hose (8) of the auxiliary spool valve and the tube (3) of the trailer brake connector.

#### 2. Remove the screws (5) and the valve (6).

#### Refitting

3. Clean the joint faces of the hydraulic cover and of the valve.
4. Replace the O-rings (1) and (2) (Fig. 3).
5. Refit the valve, fit and tighten the screws (5) to a torque of 21 - 24 Nm.
6. **Reconnect**: The tube (3) of the trailer brake connector, the supply hose (8) of the spool valve and the hose (7) of the pilot housing.
7. Bleed the main brake and the trailer brake and check the pressure. Carry out sections C and D, section 6F01.

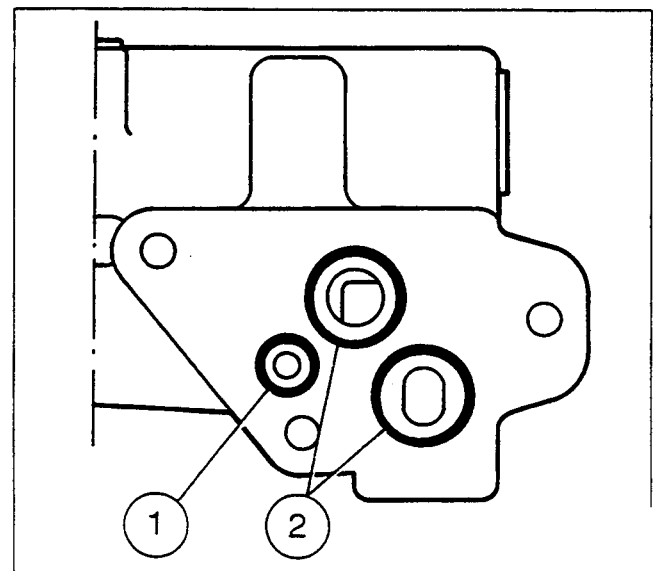



9B01.4

# Hydraulics - Trailer braking

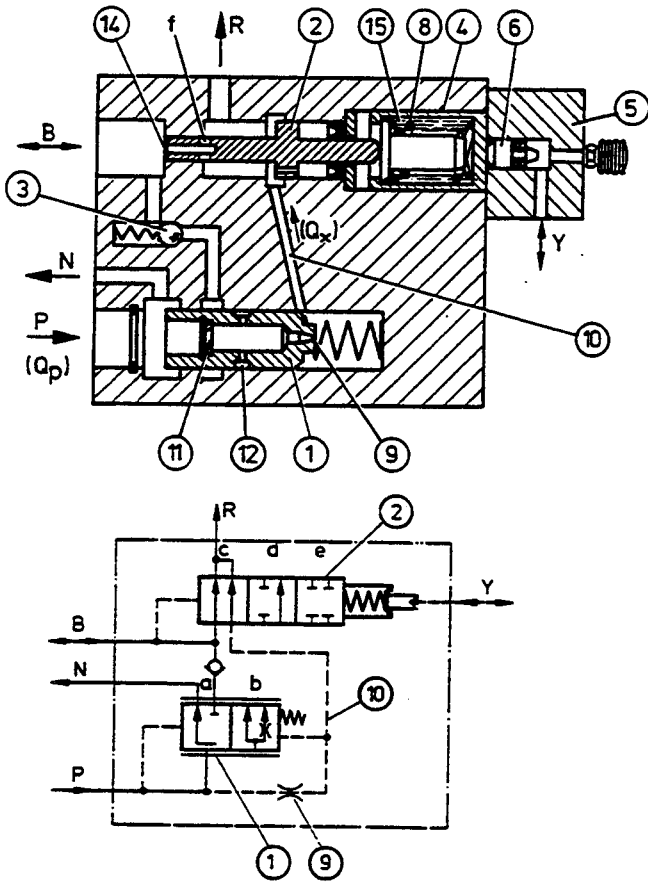

Fig. 4 - Trailer brakes released

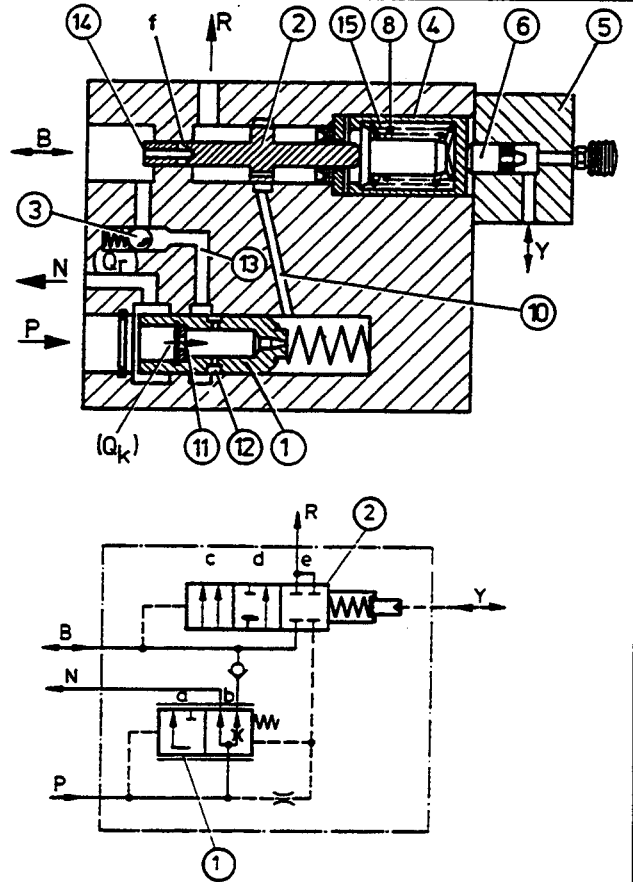
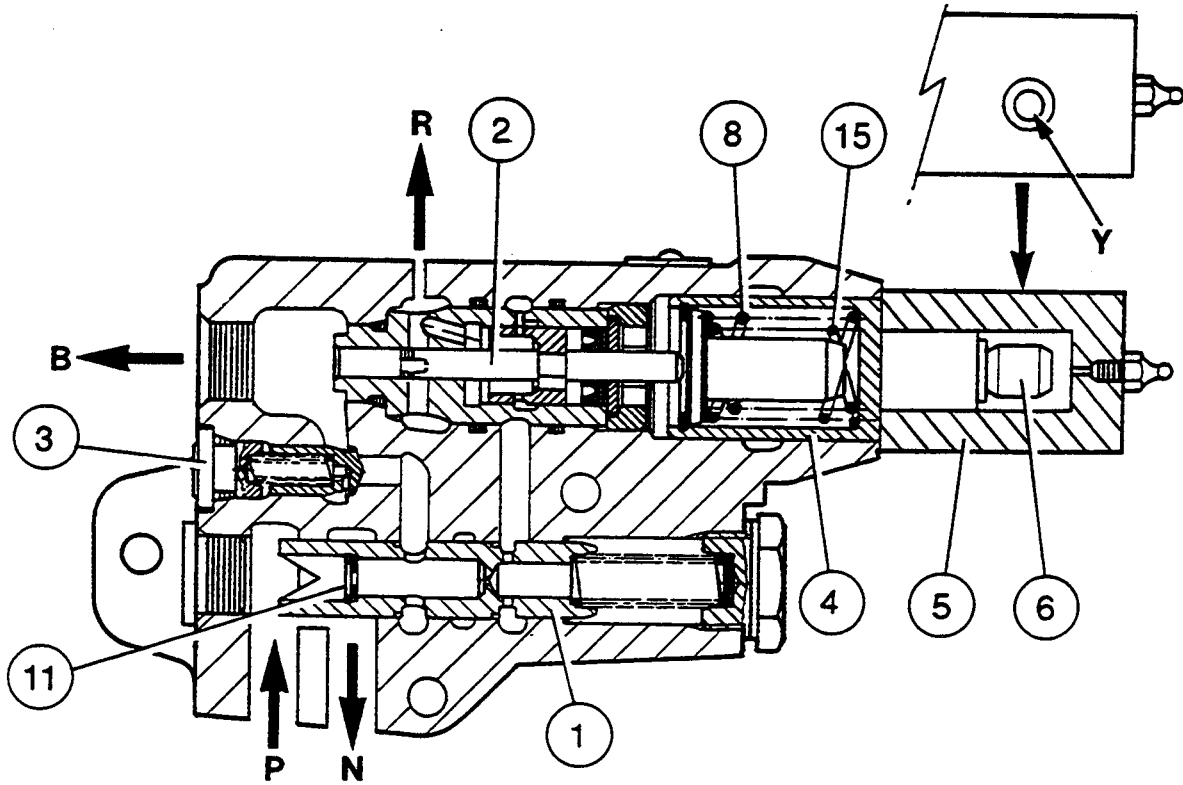

Fig. 5 - Partial trailer braking, initial braking operation.





## Hydraulics - Trailer braking

### B. Operation, trailer brakes released and partial trailer braking

#### Trailer brakes released (Fig. 4)

There is no pressure in sensing line Y (no effort applied to the pedals).

Port B (supply to the trailer brake junction) is open to return line R via channel f of the control spool (2).

Flow QP coming from the pump passes through port P in flow control valve (1).

A flow QP - QX is sent towards the port N (continuation to the auxiliary spool valve and the lift valve). A partial flow QX (approx. 0.6 l/min) coming from port P and going towards the diaphragm (11), the restrictor (9), the gallery (10) and the control spool (2) comes back to line R.

Consequently the pressure drop produced by restrictor (9) holds flow control valve (1) in the fully open position a, where it has no regulating function.

#### Partial braking of the trailer

##### Initial braking operation (Fig. 5)

The piston (6) of the pilot flow housing (5) is supplied under pressure by the tractor braking system (effort applied to the brake pedals).

The pressure arrives via port Y. The control spool (2) is then pushed to the left, obstructing channel f and interrupting the communication between port B (towards the trailer brake junction) with the return line R, and thus the connection with the gallery (10).

Control spool (2) moves from position c to position e.

Control flow QX is cut off and the flow control valve (1) moves to position b (regulating position).

A constant flow QK flows from port P to port B (towards the trailer brake junction) via the diaphragm (11), the channel (12), the line (13) and the check valve (3). The surface of the diaphragm (11) is calculated in accordance with the constant flow QK.

The residual flow QR passes through the control valve (1) then to port N (continuity to the auxiliary spool valve and the lift valve).

The line from port B (towards the trailer brake junction) is placed under pressure and acts on the surface (14) of the control spool (2) against the pressure exerted on the piston (6) by the tractor braking system.





9B01.6

6100 SERIES TRACTORS



Hydraulics - Trailer braking

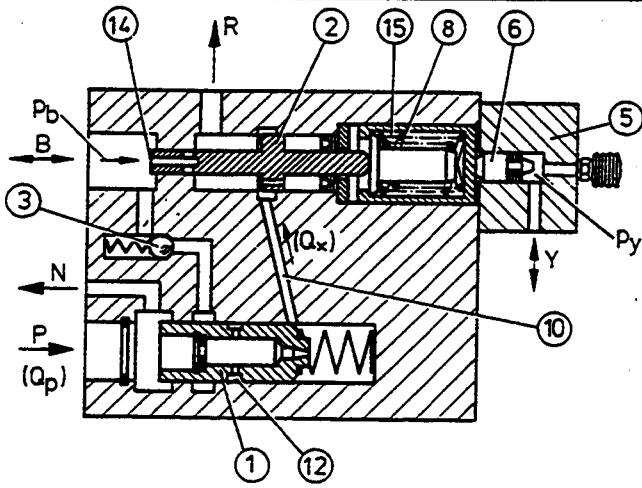

Fig. 6 - Partial braking of trailer

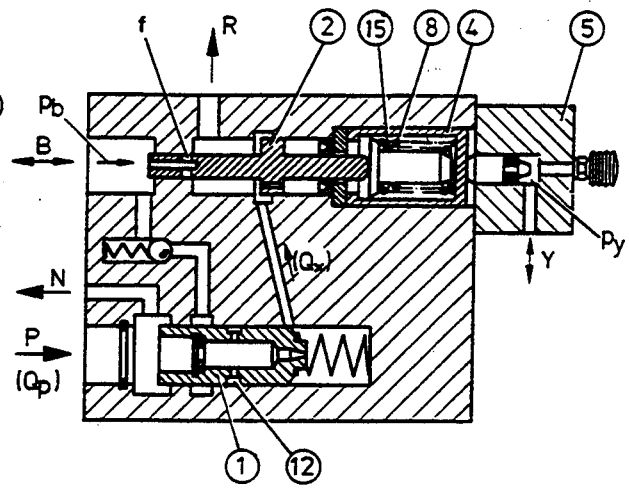
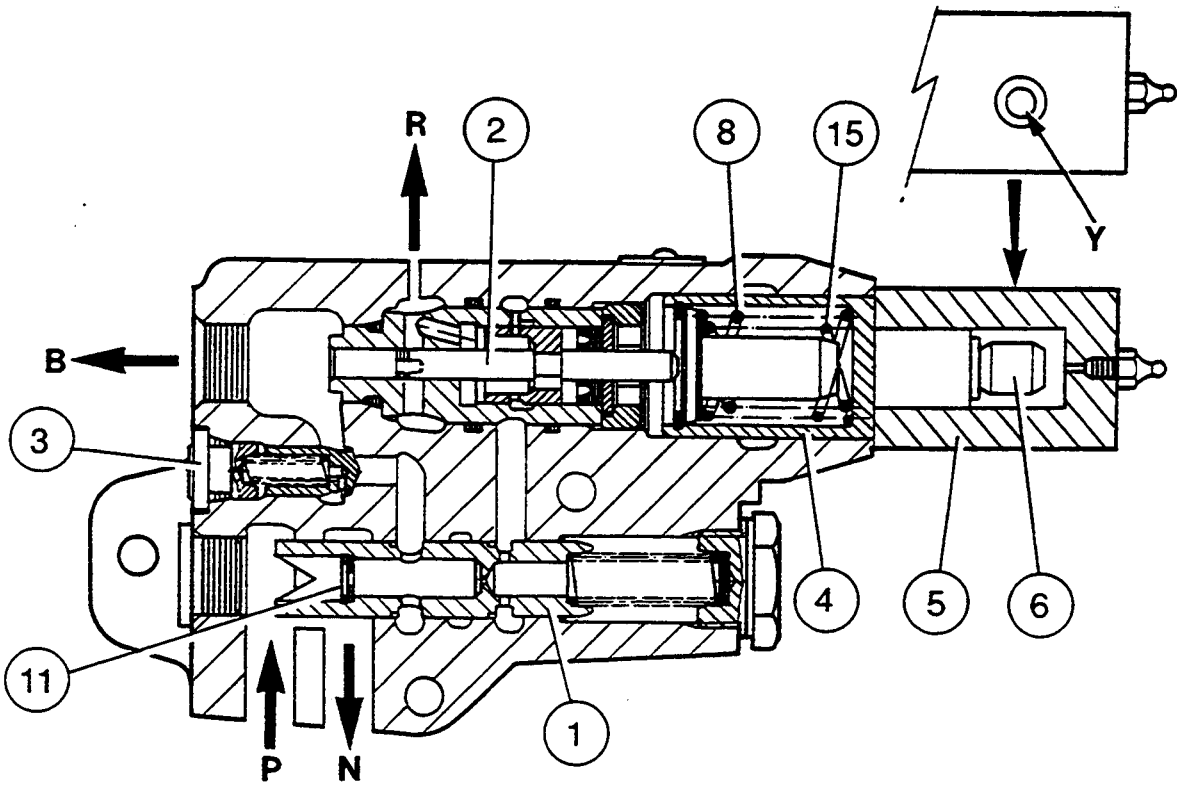
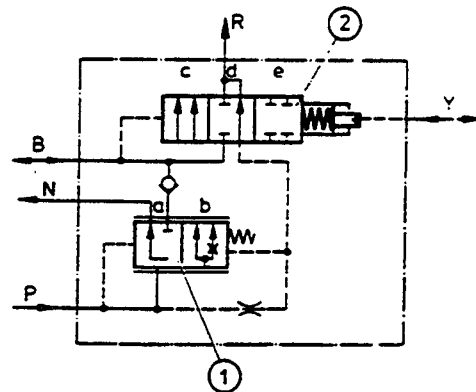
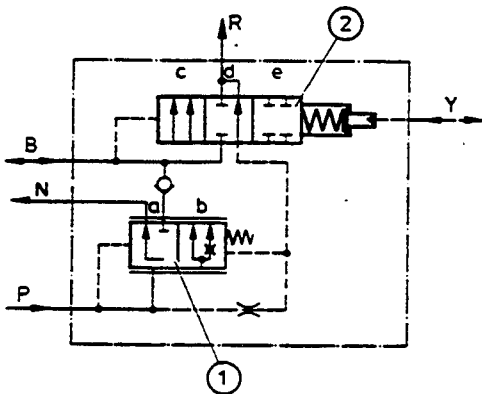

Fig. 7 - Maximum braking of trailer ; limited braking pressure





## Hydraulics - Trailer braking

### C . Partial braking and maximum braking of trailer

#### Partial braking of trailer (Fig. 6)

Pressure  $P_b$  existing in the trailer brake line (pressure acting on the active surface (14) of the control spool (2)) equalises with the pressure  $P_y$  (coming from the tractor braking system) acting on the piston (6) of the pilot flow housing (5).

The line from port B (towards the trailer brake junction) is cut off from the return port R. Therefore the oil is trapped within the trailer braking system. When the pressures have equalised the control spool (2) is in position d.

The flow control valve (1) then moves to position a, where it has no regulating function.

As when the trailer brakes are released, flow  $Q_p - Q_x$  is directed to port N (continuity to the auxiliary spool valve and the lift valve) and control flow  $Q_x$  is sent towards the return line R via the control spool (2).

#### Maximum braking of trailer (Fig. 7)

##### Limited braking pressure

Flow control valve (1) and control spool (2) occupy the same positions (a and d) as for partial braking.

Flows  $Q_p$  and  $Q_x$  are the same as for partial braking. The maximum admissible braking pressure for the trailer is attained ( $P_b = 150$  bar). There can be no increase in trailer braking pressure, even if the braking pressure of the tractor continues to increase.

The pressure relief valve (4) is then pushed to the left.

The springs (8) and (15) preloaded to the maximum admissible braking pressure for the trailer ( $P_b = 150$  bar) are compressed.

If the trailer braking pressure  $P_b$  should increase due to external influences, the control spool (2) momentarily opens channel f between orifice B (supply towards the trailer brake junction) and the return line R.

In all operating positions of the trailer brake valve, the auxiliary spool valve and the lift valve are usable via orifice N (Fig. 8) without having any major effect on the trailer braking system. This has priority over the high-pressure hydraulic circuit.

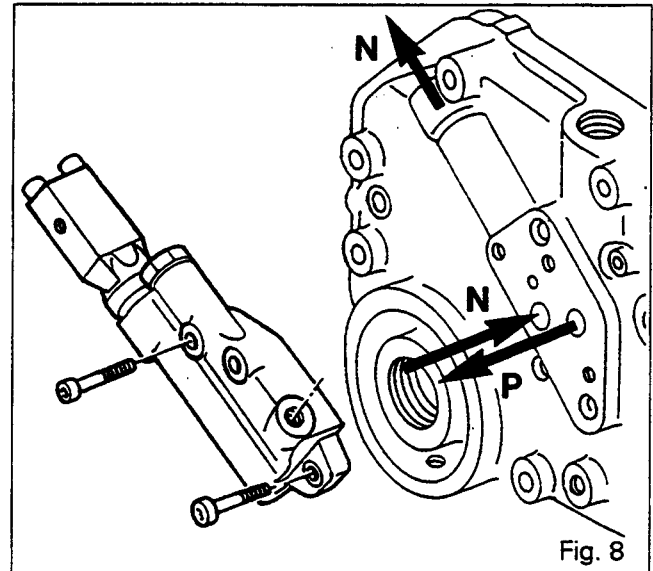





## **Hydraulics - Auxiliary spool valves**

### 9 C01 Auxiliary spool valves

#### CONTENTS

-	<b>General</b> _____	<b>2</b>
A.	<b>Flow divider</b> _____	<b>4</b>
B.	<b>3-position spool valve, single/double acting</b> _____	<b>5</b>
C.	<b>3-position spool valve, single/double acting with kickout return to neutral</b> _____	<b>6</b>
D.	<b>3-position spool valve, single/double acting, with nonreturn valve and kickout return</b> _____	<b>7</b>
E.	<b>4-position spool valve, double acting with kickout return to neutral and floating position</b> _____	<b>8</b>
F.	<b>Diagrams</b> _____	<b>9</b>
G.	<b>Fitting and adjusting the control cables</b> _____	<b>10</b>



9C01.2

## 6100 SERIES TRACTORS

**Hydraulics - Auxiliary spool valves****General**

The auxiliary spool valves are fitted on the high-pressure circuit. They are fed by the oil coming from the trailer brake valve or from the cover plate (depending on the option).

In the neutral position, the oil not used by the spool valves is available for the lift valve fitted downstream.

The auxiliary spool valves are fixed on a support which in turn is mounted on the rear of the lift cover. The quick couplings are mounted directly on the body of the spool. To obtain an adequate distance between the couplings, the spool valves contain blocks which serve as distance pieces. These blocks also permit the oil to continue to the next spool.

**Characteristics**

Each spool valve is activated by a lever in the cab, and has three phases:

- 35% slow flow
- 45% progressive increase in flow and pressure
- 20% full flow

The progressive increase in flow and pressure enables uniform control of implements.

This characteristic also enables two spool valves to be activated simultaneously, the overall flow being shared. The flow to each quick coupler is proportional to the position of the control lever.

**Different types of spool valves**

- 3 positions, convertible to single or double acting.
- 3 positions, convertible to single or double acting with kickout return to neutral.
- 3 positions, convertible to single or double acting with nonreturn valve and kickout return to neutral.
- 4 positions, double acting with kickout return and floating position.
- 3 positions with shock valves.

**Assembly procedure (Fig. 1 and 2)**

1. For correct assembly of the plates (2) and seals each spool valve must be disassembled and reassembled vertically with the end plate (11) at the bottom.
2. Screw on the nuts (12) until they touch the intake block (1).
3. Place the spool valve assembly with the fastening surfaces "F" supported on a flat surface, ensuring that it is lying perfectly flat.
4. Tighten the nuts (12) to a torque of 17 - 20 Nm.
5. Fit the connectors (13) and the pipe (3), then tighten them to a torque of 50 Nm.

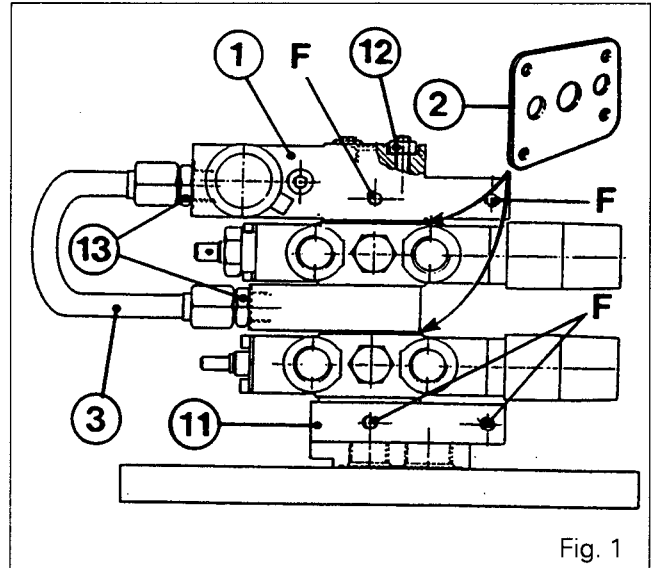

Fig. 1

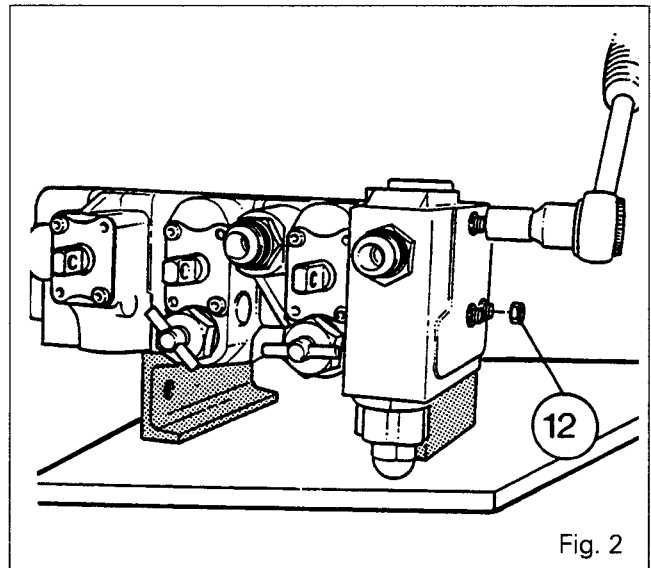

Fig. 2



## Hydraulics - Auxiliary spool valves

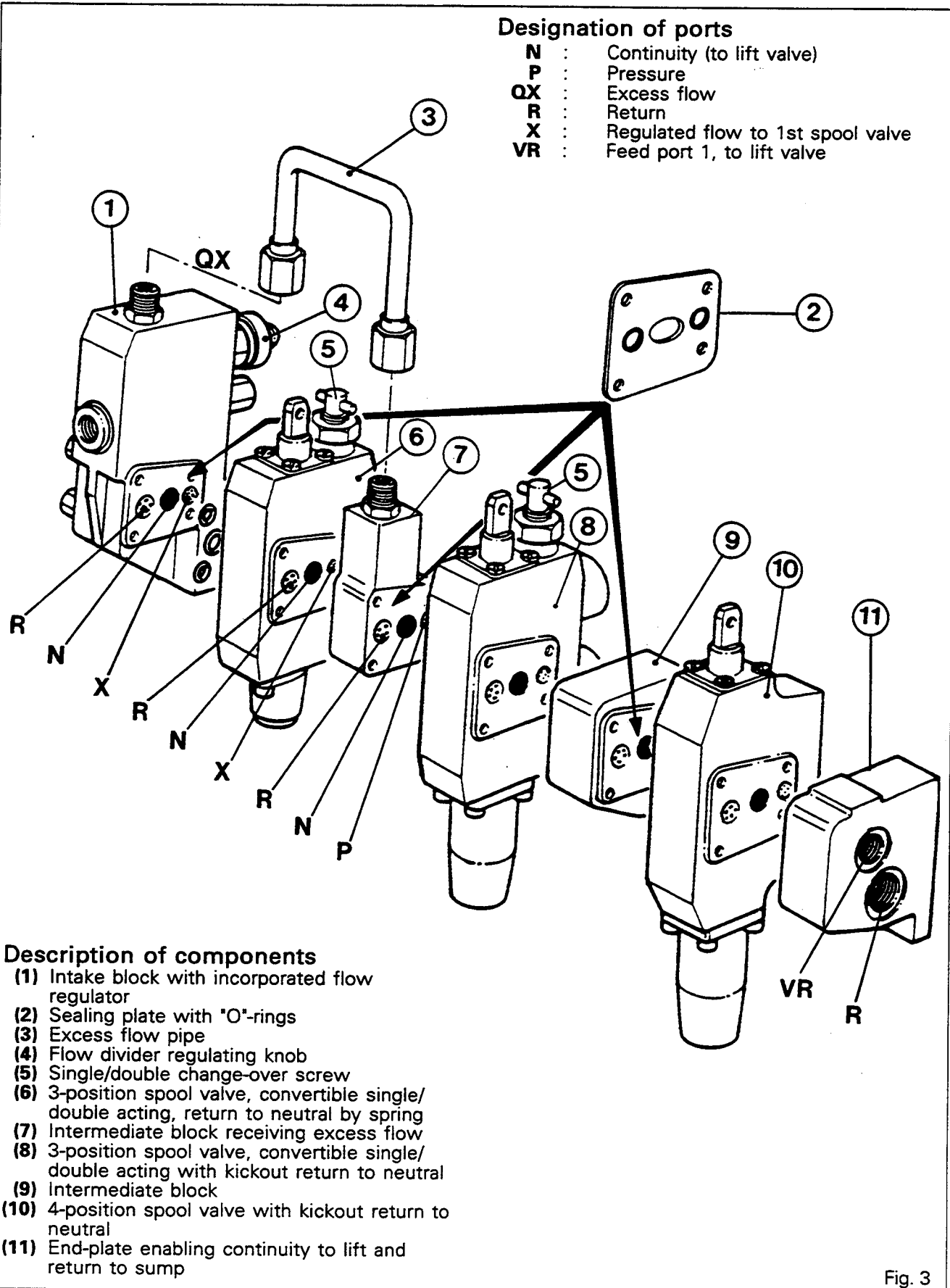

Fig. 3



9C01.4

## 6100 SERIES TRACTORS

**Hydraulics - Auxiliary spool valves****A . Flow divider**

For work requiring a regulated flow, the divider enables a variable flow to be obtained, by adjusting the knob (4) between the minimum and maximum positions (Fig. 4).

The divider is situated at the intake of the auxiliary spool valve assembly. It is fed by the oil from the high-pressure circuit passing through the brake valve or the cover plate (depending on the option).

**Operation (Fig. 5)**

The oil coming from port **N** is sent to port **X** and feeds the first spool valve. The flow is regulated according to the position of the knob (4).

At the same time, the pressure existing in channel **N** enables the oil to pass through hole "a" and restrictor "b".

The piston (7) is then moved upwards, sending the oil through the port **QX** and the intermediate block, which receives the excess flow through the pipe (3).

**Adjustment (Fig. 6)**

1. Remove the stop screw (6), the lock nut (1) and the washer (2).
2. Unscrew and remove the knob (4).
3. Without forcing it, tighten the screw (3) so that the valve (8) is in contact with its seat.
4. Screw in the knob so that it is in contact with the cap (5).
5. Unscrew the knob by two turns.
6. Screw in and tighten the stop screw (6) to a torque of 20 Nm.
7. Place the knob in the closed position (Fig. 4).
8. Fit the washer (2) and tighten the locknut (1) to a torque of 30-40 Nm.

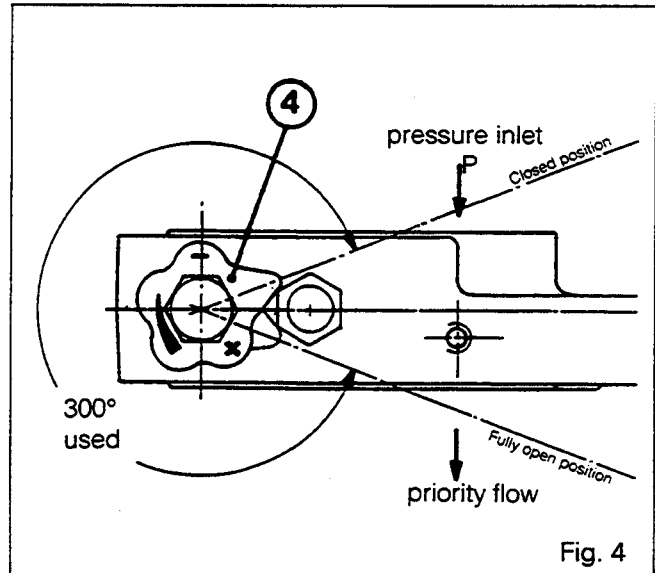

Fig. 4

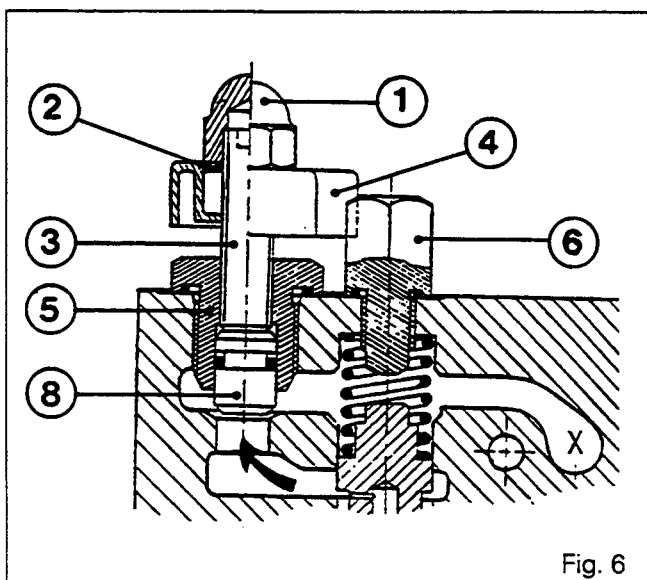
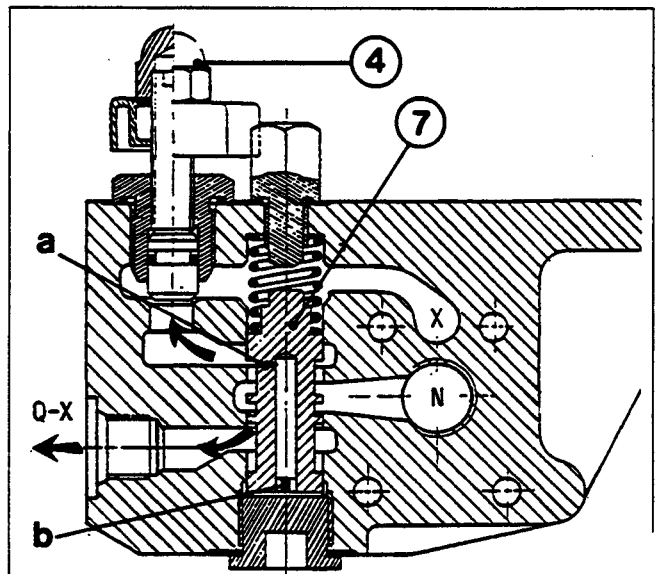

Fig. 6

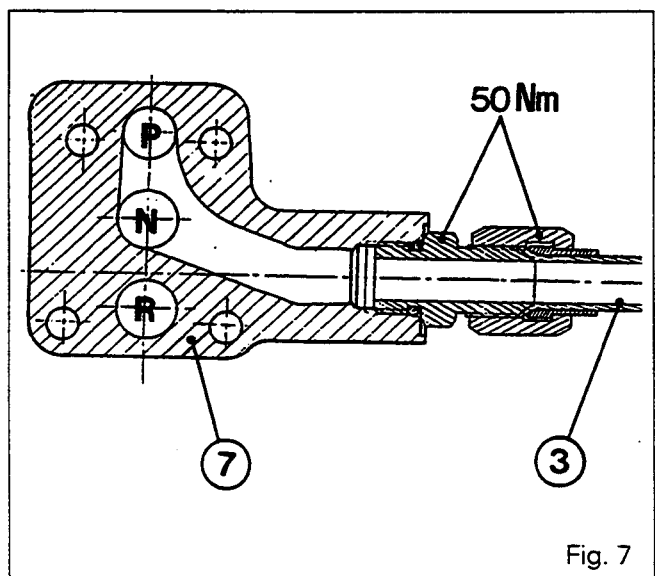

Fig. 7



## Hydraulics - Auxiliary spool valves

### B . 3-position spool valve, single/double acting

#### Operation (Fig. 8)

The oil from the high-pressure circuit passes through the brake valve (if fitted) or the cover plate fixed on the right hydraulic cover and feeds the various spool valves via the continuity channel **N**.

#### Neutral position

The oil is not available at outputs **S1** or **S2**. It is sent via the continuity line towards the lift valve and passes directly to the intake manifold of the pump when the lift is in the neutral position.

Channels **N** and **P** are connected in the intermediate block **7** (Fig. 7) to feed the following spool valves.

#### Intake - Discharge phase

When the spool **(2)** is moved to right or left, the pressure increases and lifts the valve **(1)**. The oil is sent to channel **D** or **G**, depending on the direction of movement of the spool, to feed the outputs **S1** or **S2** via grooves **g1** or **g2**. At the same time, the returning oil is sent from the ram to output **S1** or **S2**, depending on the position of the spool, and comes back to the return channel **R**.

#### Change-over single/double acting

For the single acting position, unscrew the valve **(4)**. Output **S1** is now connected to channel **R**. Output **S2** feeds the ram.

For the double acting position, screw in the valve **(4)**.

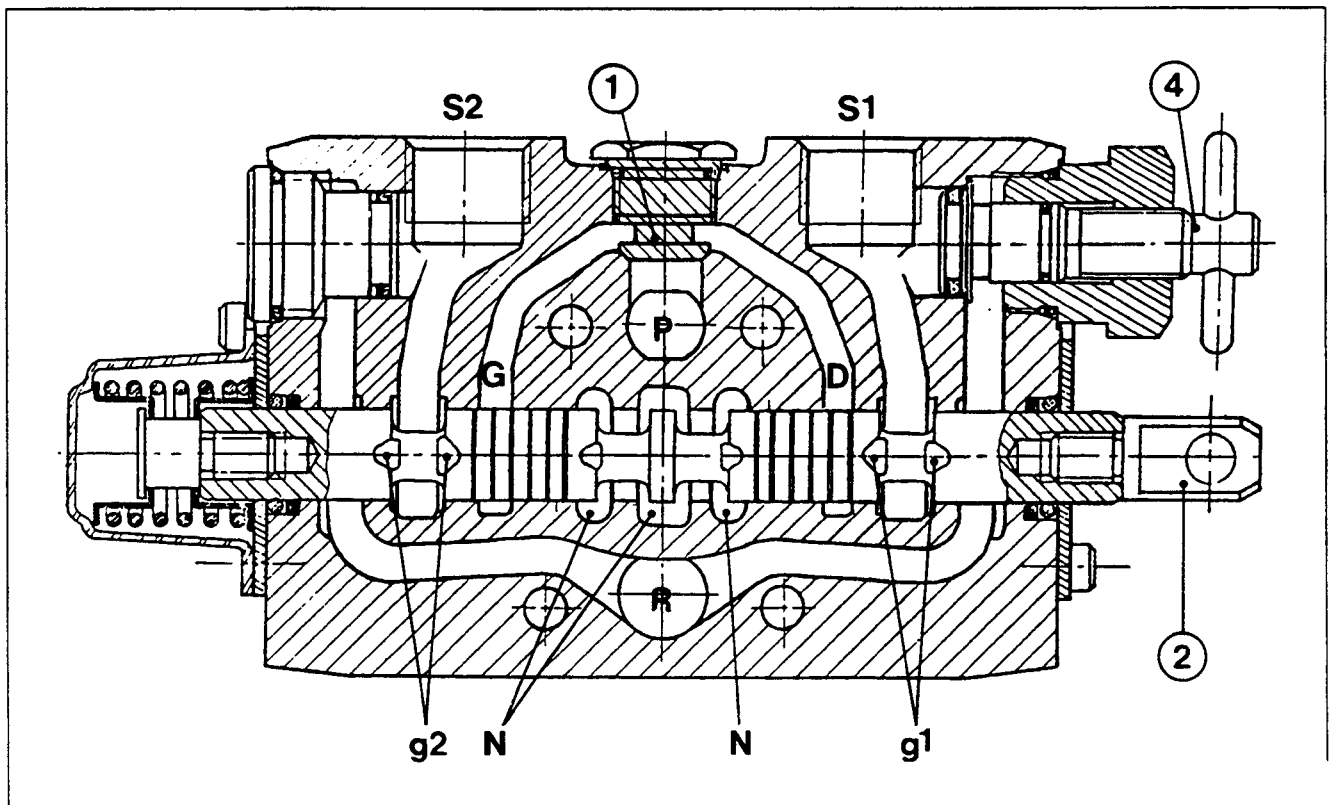





9C01.6

# 6100 SERIES TRACTORS



## Hydraulics - Auxiliary spool valves

### C. 3-position spool valve, single/double acting with kickout return to neutral

#### Operation

##### Neutral position

The operating principle of the 3-position spool valve, single and double acting with kickout return to neutral, is the same as that of the previous spool valve.

##### Intake - discharge phase (Fig. 9)

Operation identical to the previous 3-position spool valve, plus the special characteristic that it automatically returns to the neutral point.

The system in the housing (3) locks when the spool (2) is actuated.

The spool automatically returns at a pressure of 140-160 bar.

The pressure passes through the holes a and b, releases the system, and enables automatic return of the spool to the neutral position.

The housing (3) is in communication with channel R.

Residual pressure in the housing (above 2 bar) may cause the spool to return to neutral.

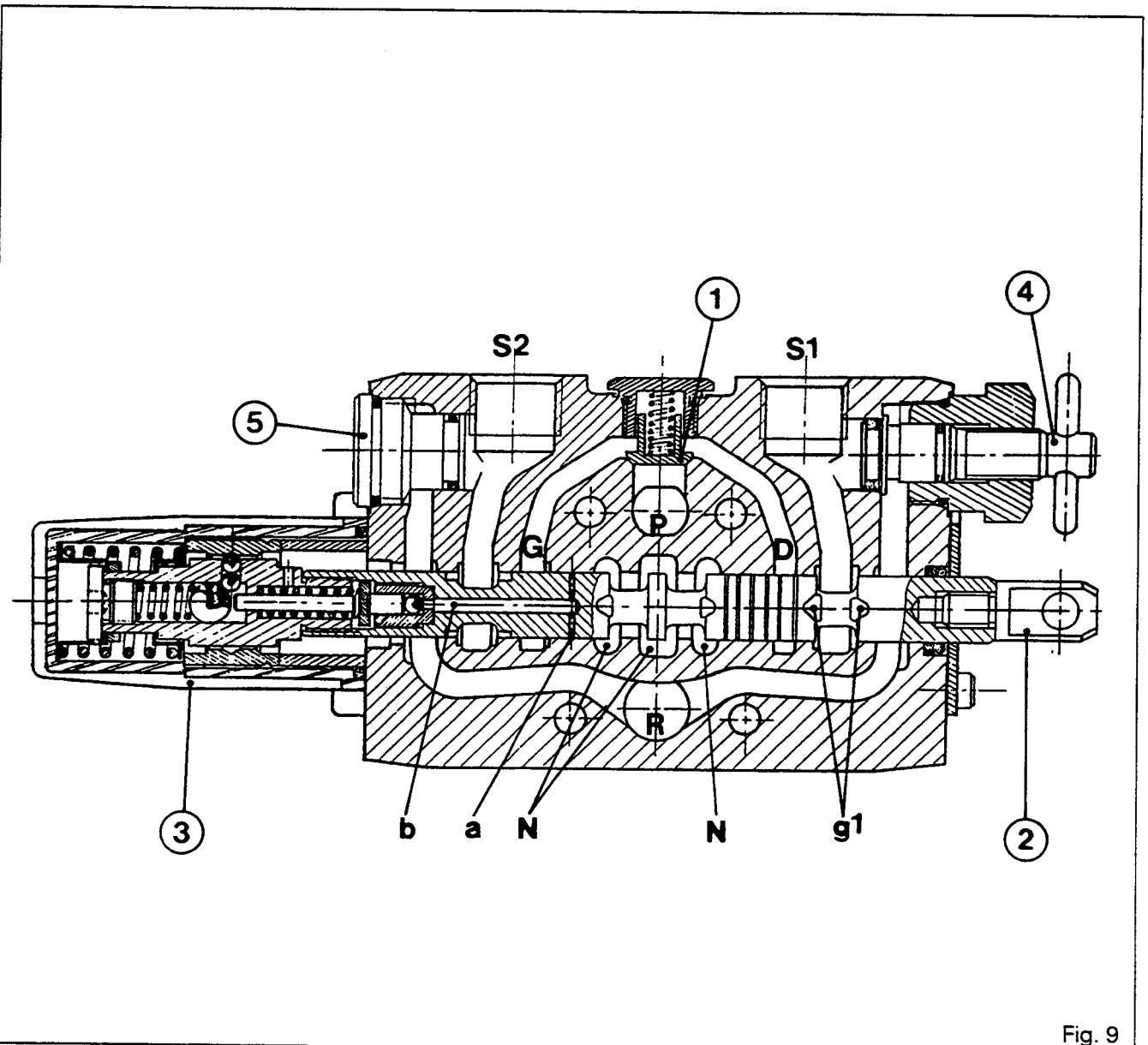

Fig. 9



## Hydraulics - Auxiliary spool valves

### D. 3-position spool valve, single/double acting, with nonreturn valve and kickout return

This spool valve operates in the same way as the previous ones.

#### Operation of check valve (Fig. 10)

When the spool (2) is moved to the right, the oil coming from channel **N** is sent to the output **S2**, lifting the check valve (6) to feed the service side.

In the neutral position, the check valve seals the circuit.

When the spool (2) is moved to the left, the oil coming from channels **N** and **P** lifts the valve (1) and is sent to channel **D** to feed the service side via grooves **g1** and output **S1**.

In its movement, the spool moves the needle (5) which lifts the ball and causes the pressure to drop on the service side, enabling the valve (6) to lift from its seat and oil to flow towards channel **R**.

**Note: When dismantling the spool, it is essential to dismantle the checkvalve (6) and the needle (5) first.**

**The spool valve body is available as spare part paired with the spool (2), the needle (5) and the valve (6).**

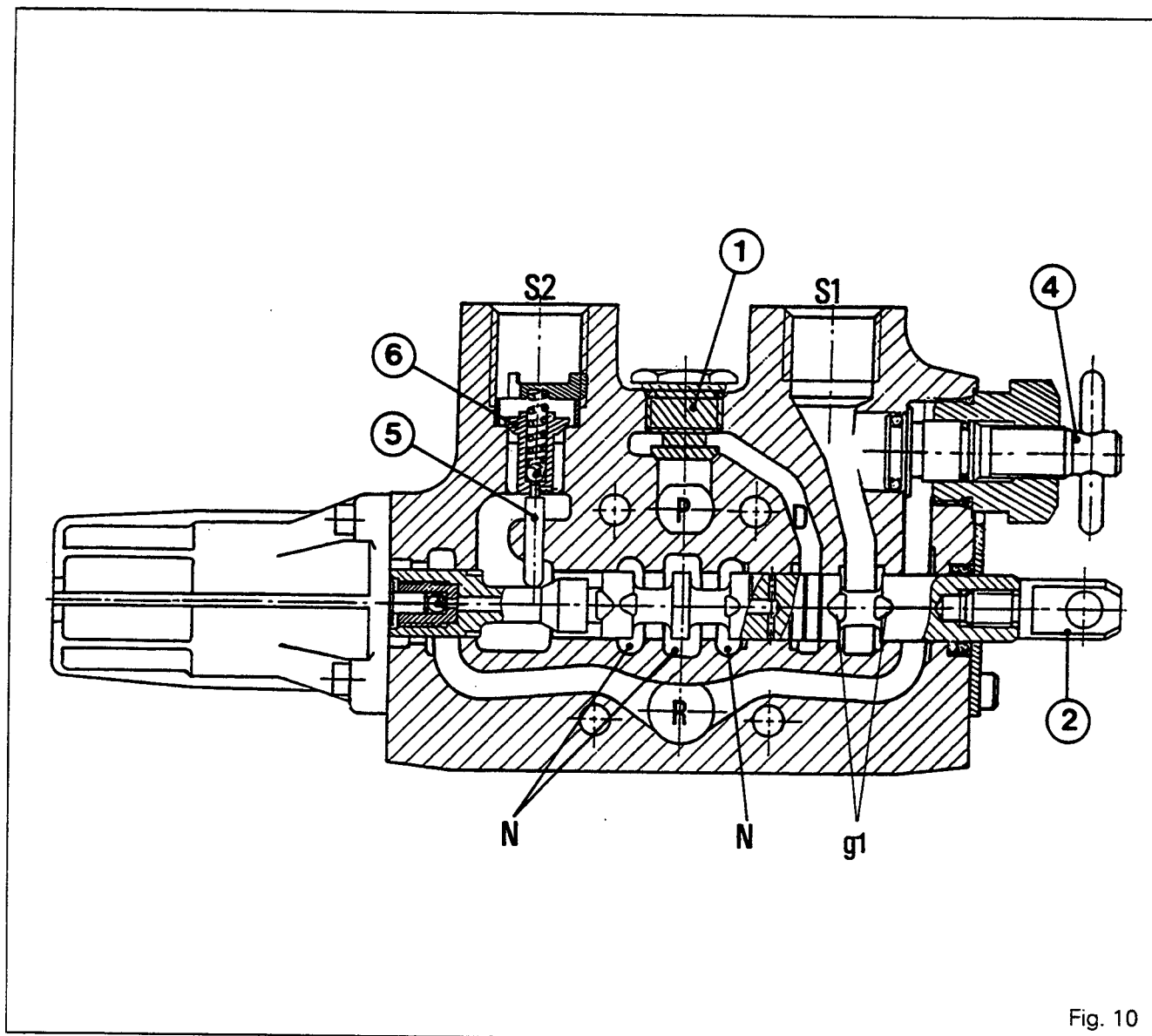

Fig. 10



9C01.8

# 6100 SERIES TRACTORS



## Hydraulics - Auxiliary spool valves

### E. 4-position spool valve, double acting with kickout return to neutral and floating position

#### Operation (Fig. 11)

When the spool (2) is moved to right or left, the same positions are obtained as with the previous spool valves.

The special characteristic of this spool valve is that it has a floating position F, when the spool is withdrawn as far as possible, beyond the kickout return to neutral position.

In this F position, the channels of outputs S1 and S2 are connected with the return channel R. Therefore the oil can circulate freely.

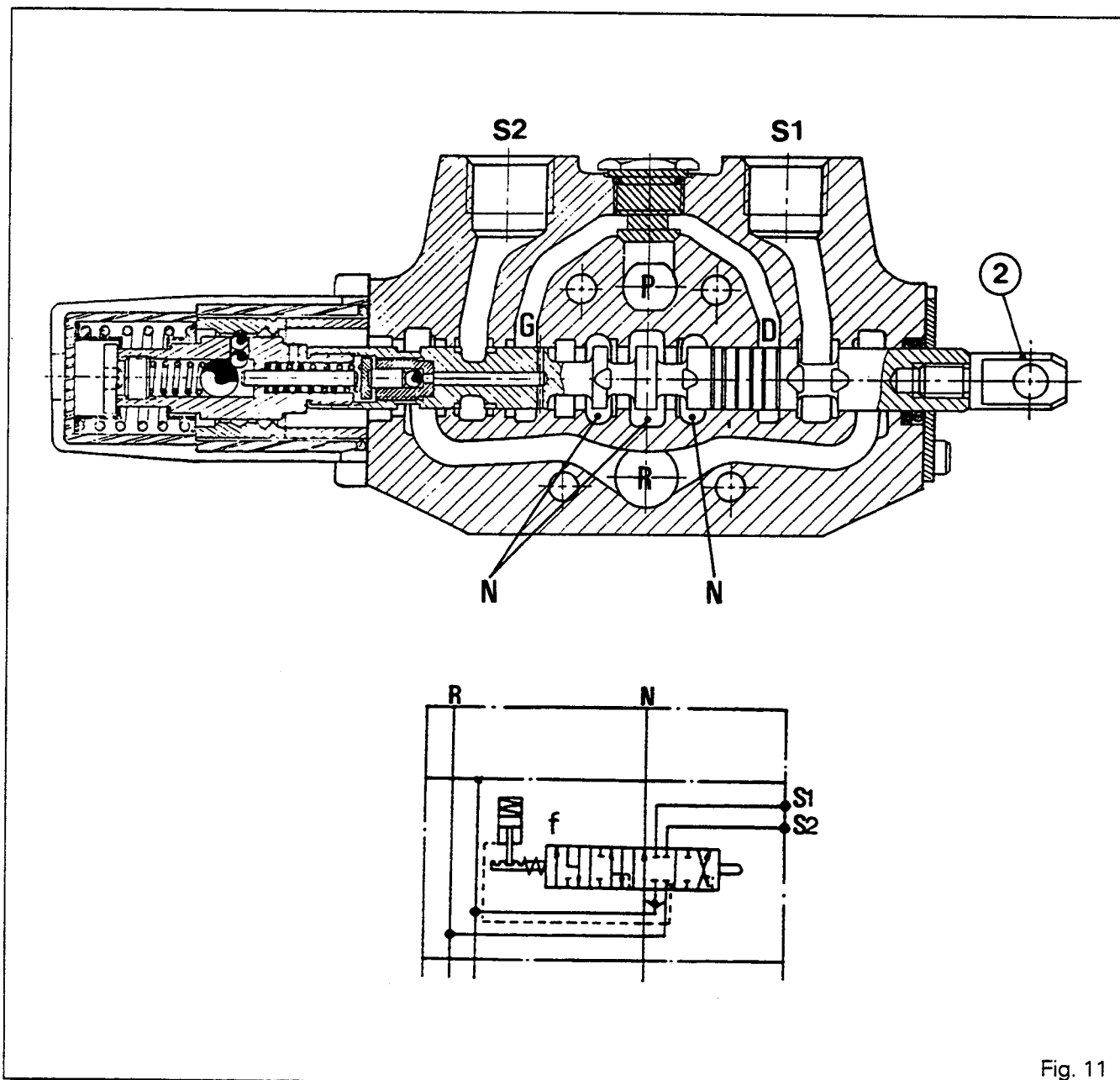

Fig. 11



F. Diagrams

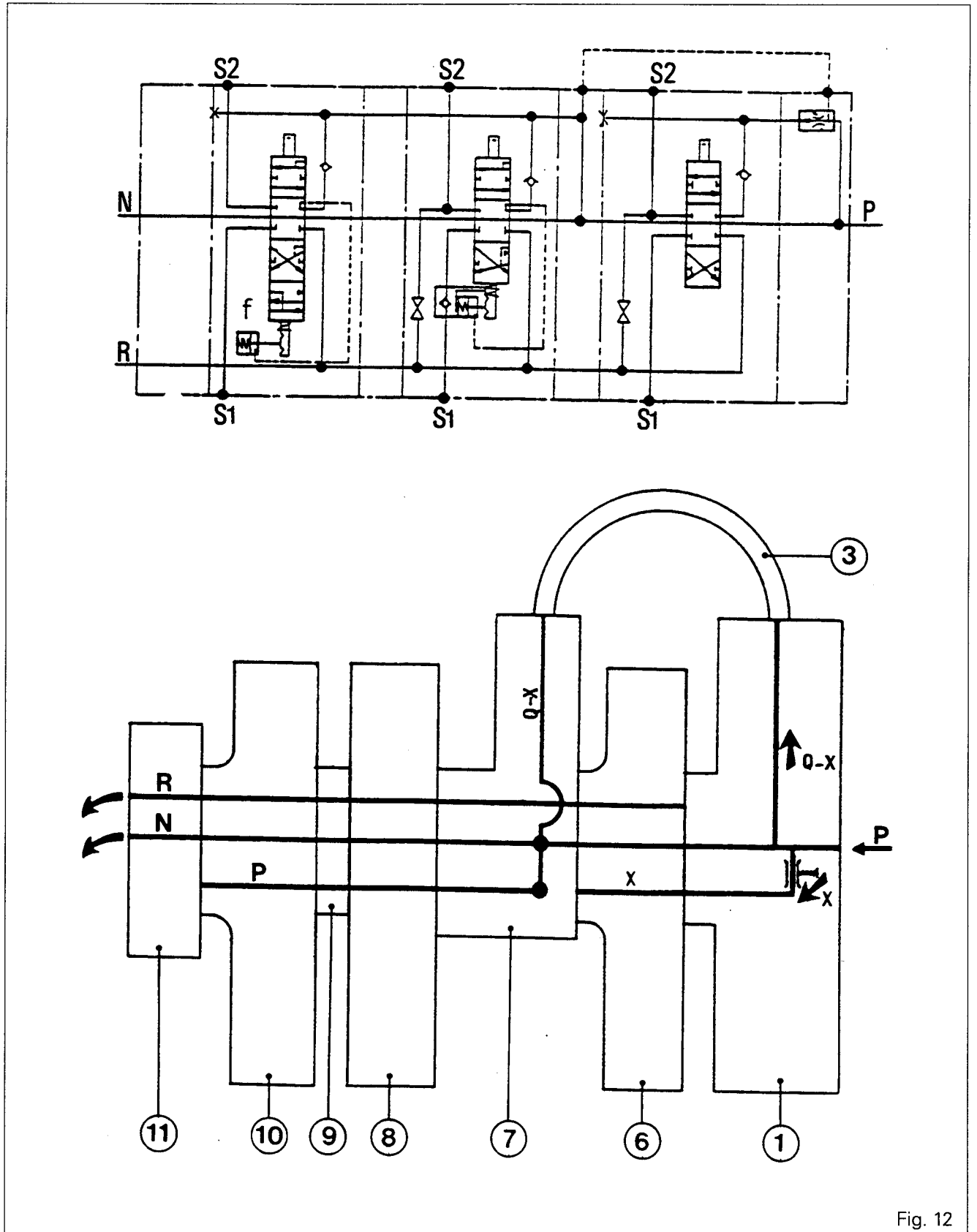

Fig. 12



9C01.10

## 6100 SERIES TRACTORS

**Hydraulics - Auxiliary spool valves****G. Fitting and adjusting the control cables****Points to note : Fig.13**

Before being mounted, pins (5) should be smeared with Loctite 241 or equivalent.

The numbers 1 to 4 indicate the assembly order for fitting the levers to the spool valves. The thrust washers (4) should be coated in molybdenum disulphide before assembly.

The nuts (8) should be tightened so as to slightly restrict the thrust washers (4).

**On support and lever**

**Note:** According to the type of unit, the clevis (1) can be attached to rod A or B. Fig. 14.

**Assembly A : std spool valves**

**Assembly B : with floating position**

1. Insert the cable into the slide at the back right-hand-side of the cab in the base (6).

**Note:** When the base (6) is displaced (floating position) assemble the spacer (1) and the plate (2) following Fig. 15.

2. Screw the clevis (1) to the end of the cable thread (2) and attach it to the rod A or B of the appropriate lever L using the clip (7) Fig. 14. Tighten the nut (3) and check that the cable moves freely, FIG. 14.

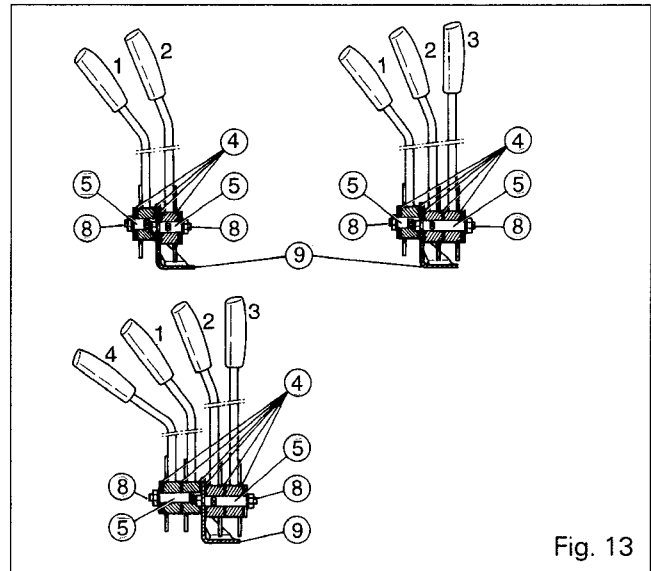

Fig. 13

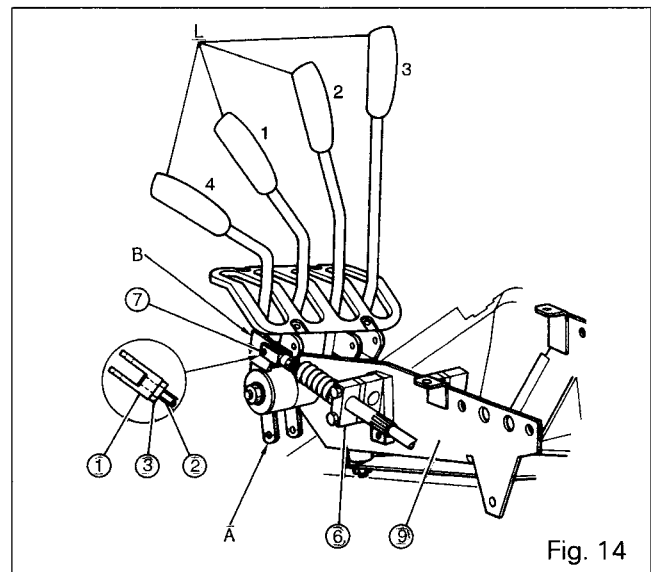

Fig. 14

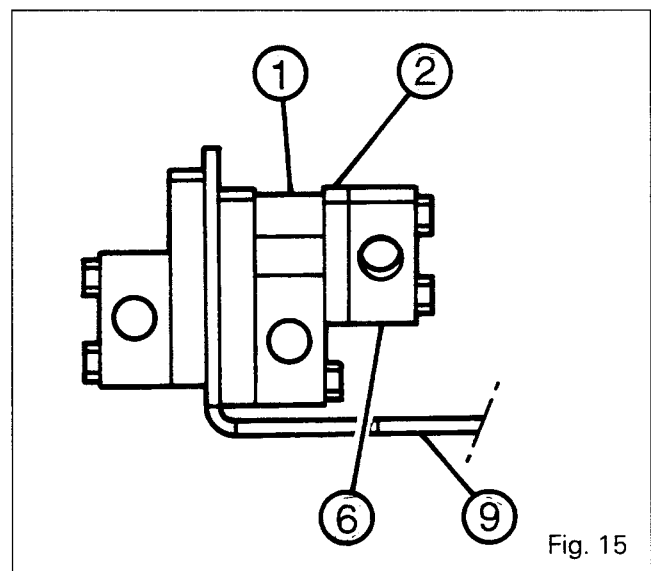

Fig. 15



## Hydraulics - Auxiliary spool valves

9C01.11

### On the spool valves (Fig.16)

3. Check that the spool valves are in a neutral position.
4. Screw the clevis (1) to the end of the cable thread (2). Tighten the nut (3) and attach the pin (4).
5. Partially screw the cover (5) and place the screws (6) without tightening them.
6. Adjust the cover so that the lever is correctly positioned in respect to the plates (1) Fig. 17.
7. Screw in the screws (6) and tighten the nut (7) to a torque of 20 Nm.
8. Verify that the controls operate in the three or four positions available - according to the option.

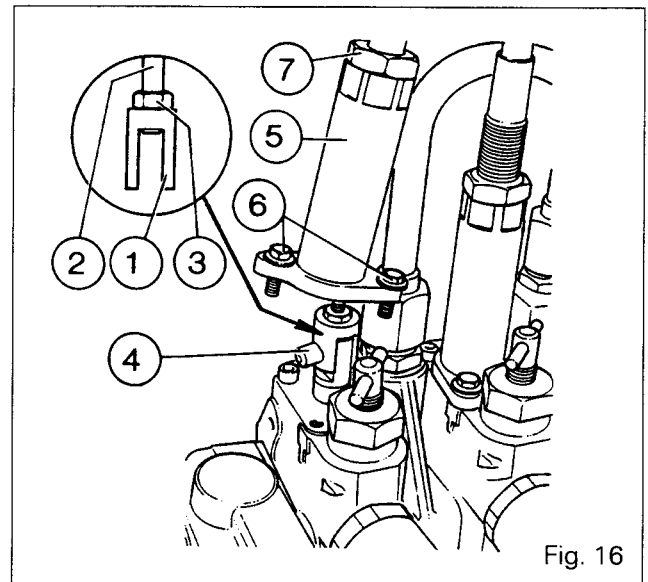

Fig. 16

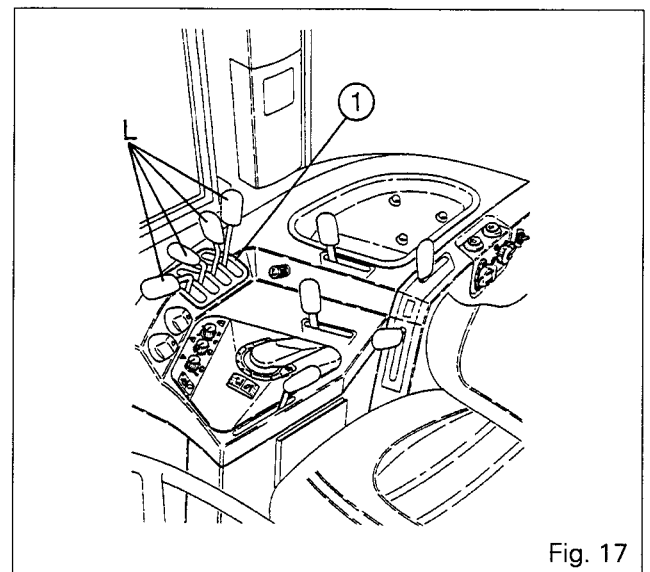

Fig. 17





**Hydraulics** - Lift Control Valve

9 D01 Lift Control Valve

CONTENTS

-	<b>General</b> _____	<b>2</b>
A.	<b>Neutral position</b> _____	<b>3</b>
B.	<b>Lift phase</b> _____	<b>4</b>
C.	<b>Lower phase</b> _____	<b>5</b>
D.	<b>Removing and refitting the lift control valve</b> _____	<b>6</b>





9D01.2

---

## 6100 SERIES TRACTORS

---



# Hydraulics - Lift Control Valve

---

### General

The lift valve is fixed on the left cover mounted on the centre housing. Its function is to regulate the flow of oil to and from the lift cylinders according to the signals transmitted to it by the computer of the electronic control system. This valve is composed of a series of spools and valves, most of which are not reparable as separate parts.

### Description

The BOSCH hydraulic valve controls the supply to the lift cylinders and is composed of two sections:

#### Hydraulic section comprising the following parts:

- (1) Nonreturn valve, maintaining oil in the cylinders.
- (2) Servo piston used in the lower phase.
- (3) Nonreturn valve used in the lower phase.
- (4) Control spool valve.
- (5) Flow regulator spool valve.
- (6) Shock valve set at 200 bar.
- (9) Spool valve spring, flow regulation.
- (10) Control spool valve spring.
- (11) Control spool valve spring.
- (12) Nonreturn valve ball.
- (13) Restrictor.

#### Electrical section comprising two electromagnetic coils:

- (7) Lower solenoid.
- (8) Lift solenoid.

#### Designation of ports:

- N** : Continuity port towards transfer tube and pump intake (via 5-bar check valve for tractors equipped with brake lubrication system).
- P** : Pressure.
- R** : Return to housing.
- V** : Cylinders supply and return.

**Note: To distinguish between a hydraulic fault and an electrical fault, simply operate the push-buttons at the ends of the solenoid valves, thereby eliminating the effect of the electronic lift system.**



## Hydraulics - Lift Control Valve

### A. Neutral position

When the engine is stopped, the control valve is in the neutral position. The spool valve (4) is held in position by the springs (10) and (11).

The flow regulator spool valve (5) is pushed towards the left by the spring (9).

When the engine is running, the hydraulic pump supplies the spool valve via the braking valve (if fitted) and the auxiliary spool valves. Pressure is delivered via orifice P. The oil flows initially through hole «a» and orifice «b». Because orifice «b» is smaller than hole «a», there is a pressure drop on the spring (9) side.

This action causes a control flow to be established which passes to the spool valve (4) and then to the return orifice R on the casing.

Once the control flow is established, the spool valve (5) moves to the right to a position which maintains the control flow and thus enables the oil to be directed towards the intake of the pump via the continuity orifice N and the transfer tube.

When the spool valve is brought back to the neutral position from the lower position, a channel from behind the piston (2) to the return line C is still open.

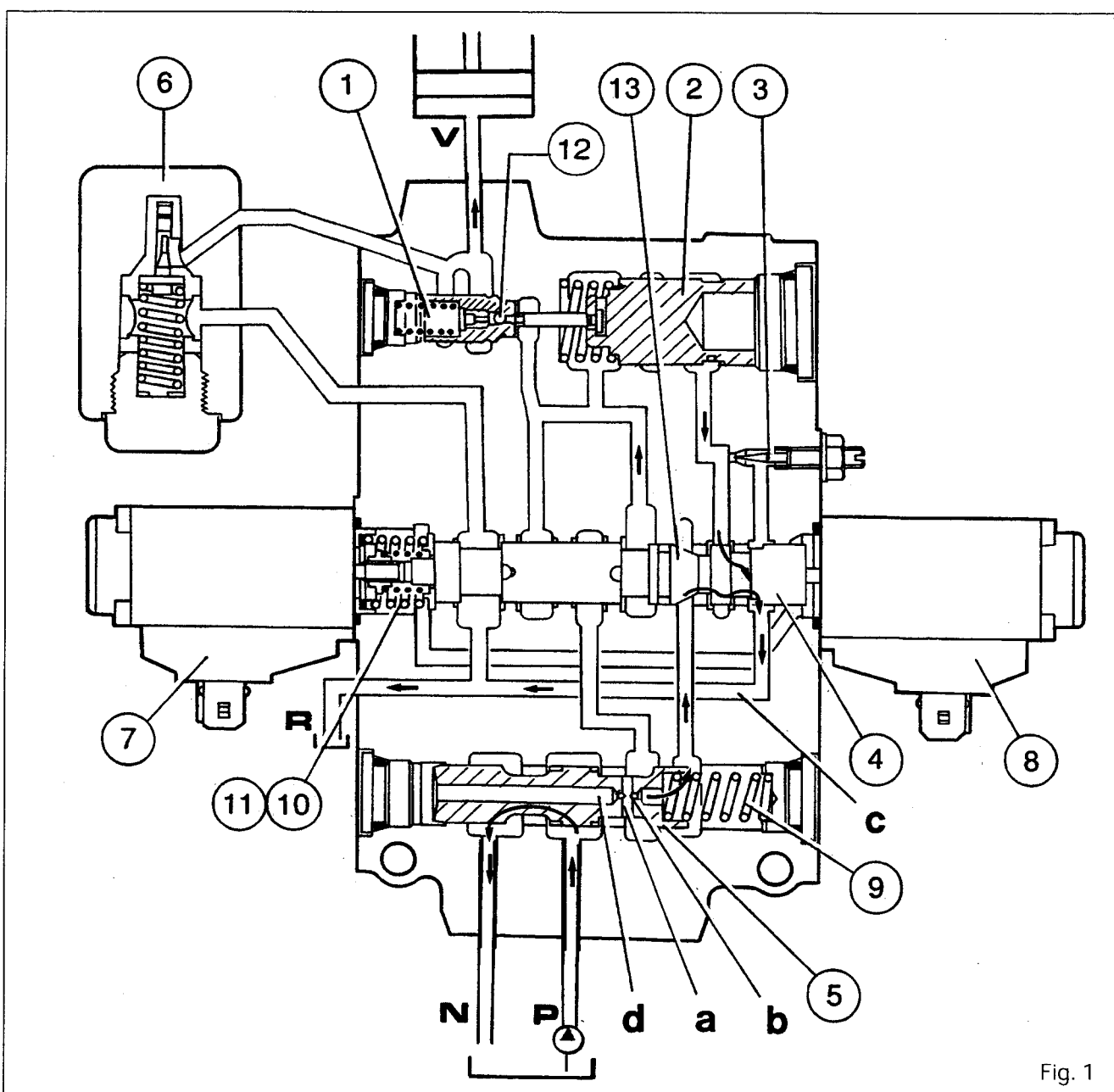

Fig. 1



9D01.4

## 6100 SERIES TRACTORS

**Hydraulics - Lift Control Valve****B. Lift phase**

The lift solenoid (8) is actuated to raise the tractor linkage.

The control spool valve (4) moves to the left and stops the control flow, placing the chamber of the spring (9) under pressure and pushing the spool valve (5) to the left.

The movement is dampened by the volume of oil flowing through orifice **d**.

The spool valve (5), having moved to the left, enables the main flow to be directed to the spool valve (4) and to the nonreturn valve (1).

As soon as the pressure on the nonreturn valve is greater than the pressure in the channels of the cylinders, the valve opens and linkage rises.

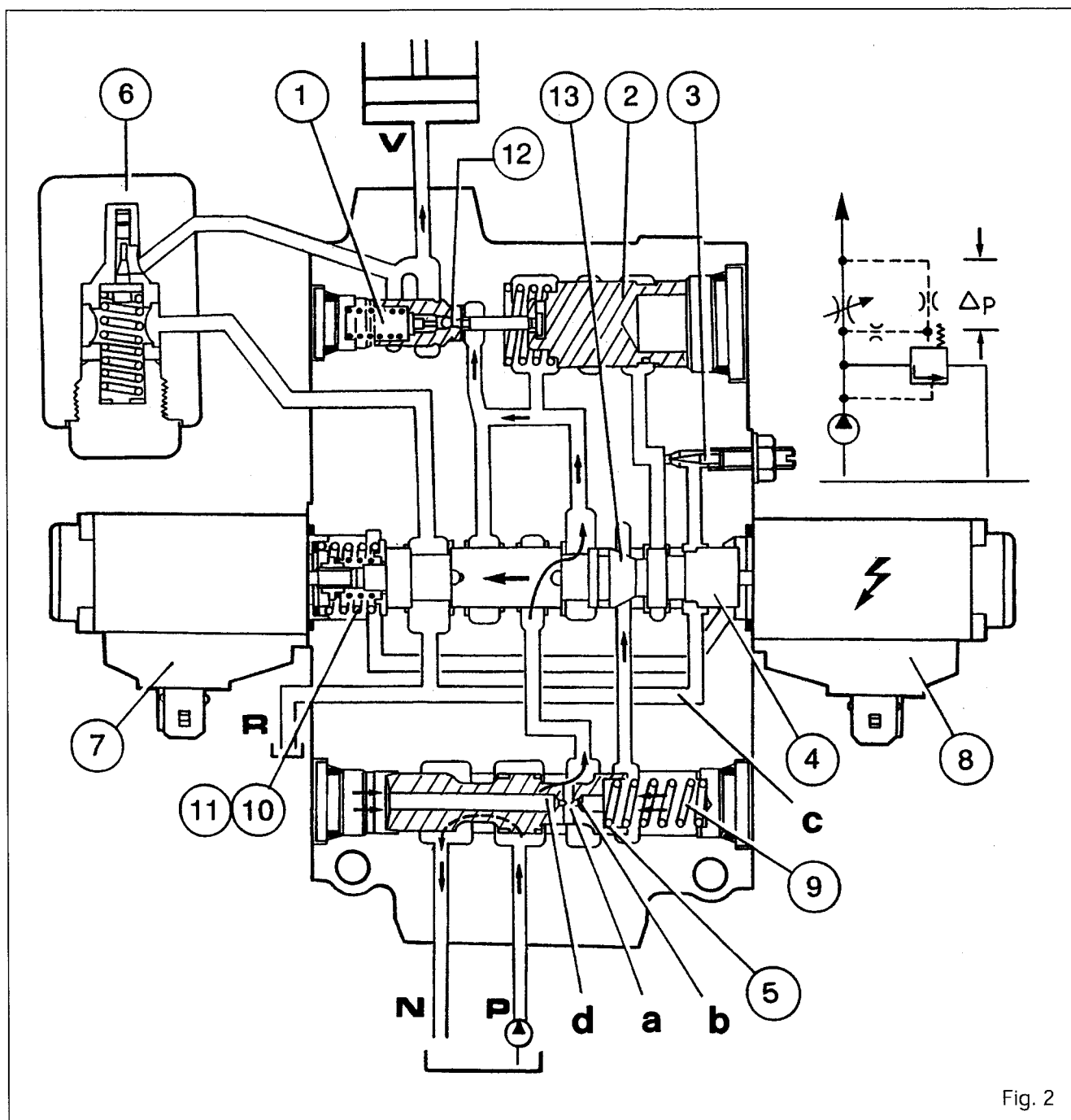

Fig. 2



## Hydraulics - Lift Control Valve

### C. Lower phase

The lower solenoid (7) is actuated to lower the tractor linkage. The control spool valve (4) moves to the right. The control flow stops and the return channel from the piston (2) is closed. Oil is directed under pressure via the hole a, the orifice b and the restrictor (13) towards the piston (2) which is moved to the left.

The rod at the end of the piston (2) lifts the ball (12) of the nonreturn valve (1) from its seat, firstly causing a pressure drop in the lift cylinders circuit. Secondly, the

piston (2) opens the valve (1), enabling the oil returning from the cylinders to be directed towards the return port R to the housing. As the movement of the piston (2) is limited, the control flow is reestablished, and is directed towards the nonreturn valve (3), the return port C and the return port R to the housing. The lower phase has no effect on the spool valve (5) which is in a floating position. It enables the minimal flow required for control purposes and ensures that the main flow is able to pass to the pump intake via the continuity port N and the transfer tube.

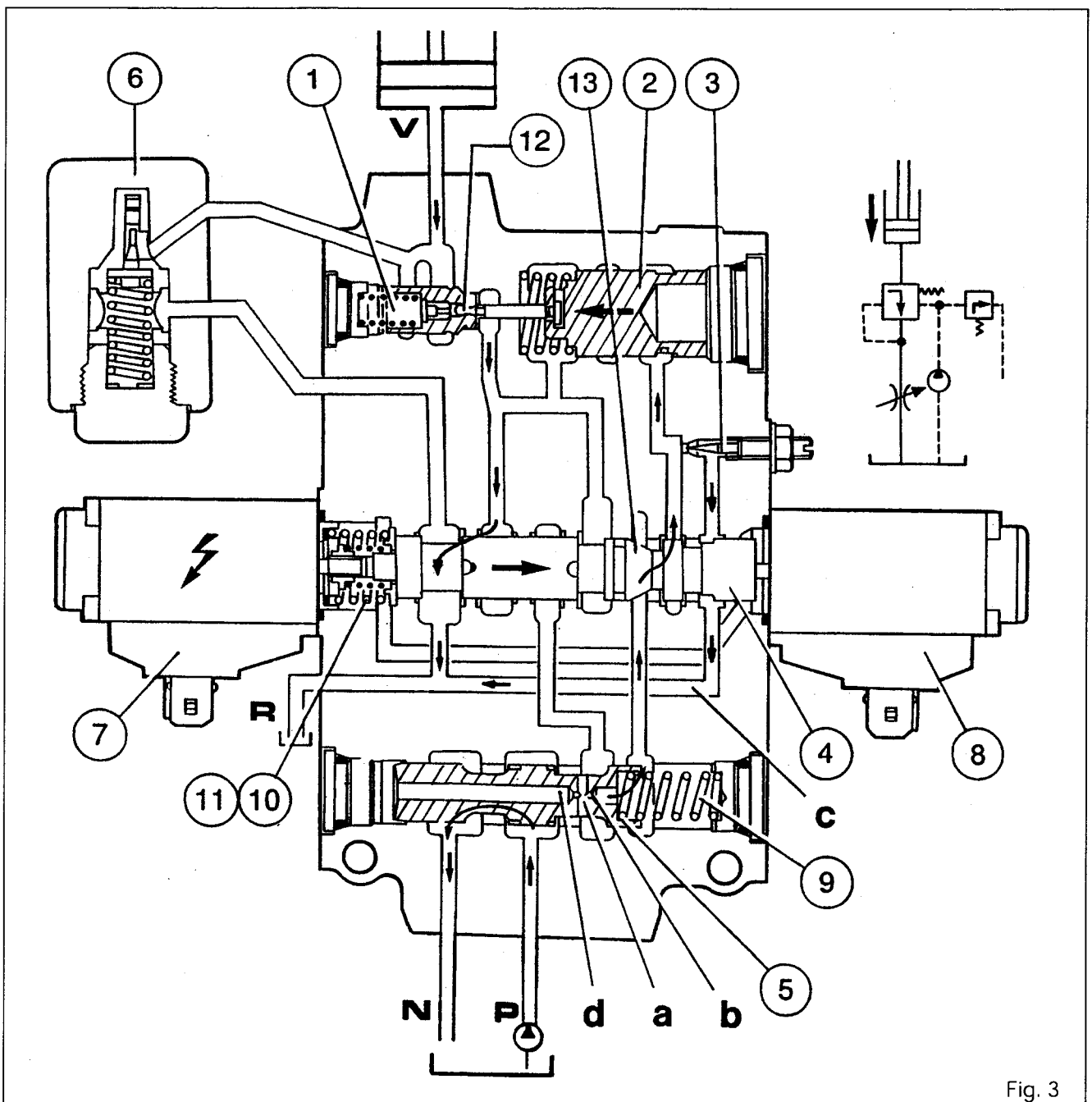

Fig. 3



9D01.6

## 6100 SERIES TRACTORS

**Hydraulics - Lift Control Valve****D. Removing and refitting the lift control valve (Fig. 4)****Removal**

1. Mark and disconnect the harnesses of the lift **(1)** and lower **(2)** solenoid valves (Fig. 4A).
2. Disconnect and plug the supply hose **(3)** of the valve and the supply tube **(4)** to the lift cylinders (Fig. 4A).  
On tractors equipped with the brake lubrication system, disconnect the union **(10)** and the tube **(11)** (Fig. 4B).
3. Remove the screws **(7)**.

**Refitting**

4. Clean the joint faces of the cover and of the valve.
5. Change the seals **(1)**, refit the valve (Fig. 5).
6. Fit and tighten the screws **(7)** to a torque of 25-35 Nm.
7. Reconnect the hose **(3)** and the tube **(4)**.
8. Reconnect the lift **(1)** and lower **(2)** solenoid valves (yellow connector).
9. With a clip, fasten the cable on the valve supply hose.
10. Start the engine.
11. Check the operation of the lift system and check the seals and hydraulic connectors for leaks.

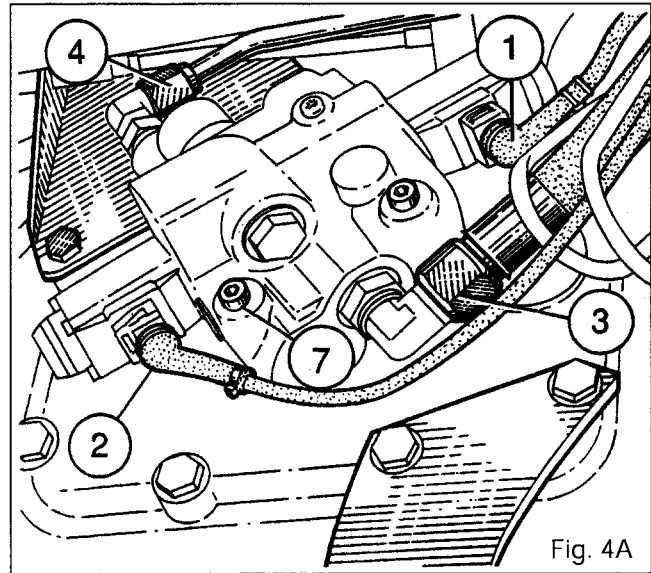

Fig. 4A

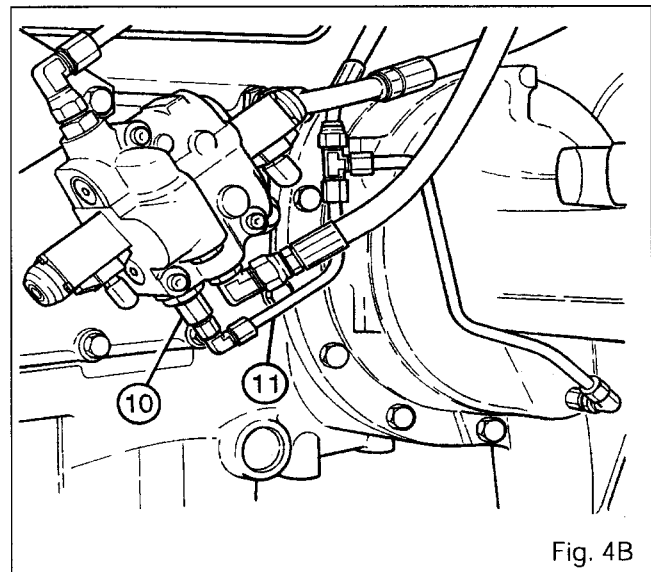

Fig. 4B

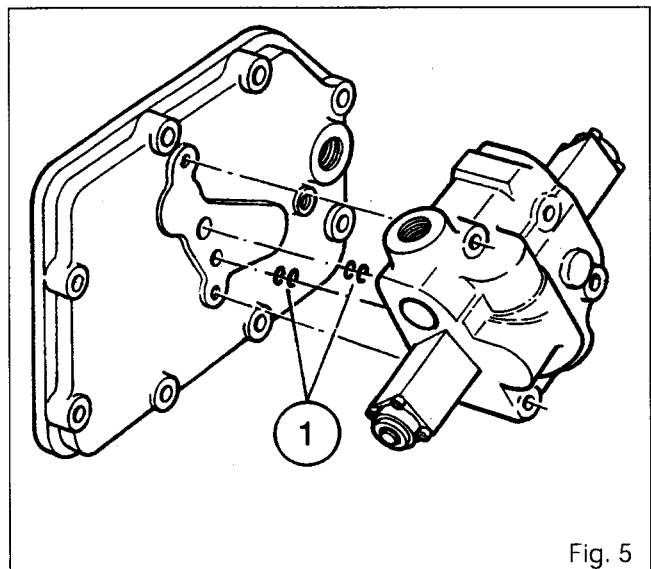

Fig. 5



9 E01 *Hydrostatic steering*

CONTENTS

- <b>General</b> _____	<b>2</b>
<b>A. Neutral position (engine running)</b> _____	<b>4</b>
<b>B. Wheel turning (engine running)</b> _____	<b>5</b>
<b>C. Manual steering (engine stopped)</b> _____	<b>6</b>
<b>D. Disassembly and reassembly of the steering unit (Orbitrol)</b> _	<b>8</b>



9E01.2

## 6100 SERIES TRACTORS

### Hydraulics - Hydrostatic steering



#### General

The steering system used on 6100 series tractors is a hydrostatic system with no mechanical linkage between the steering wheel and the steering cylinder. The main components of the system are as follows :

- A pressurised oil feed supplied by the low-flow stage of the hydraulic pump.
- A hydrostatic steering unit (Orbitrol).
- A double acting steering cylinder fitted on the 4WD front axle or the 2WD axle.

The Orbitrol is supplied by the low-flow system as a matter of priority. When the steering wheel is turned, the required flow of oil is sent to the relevant side of the steering cylinder. The excess flow not required for steering, combined with the oil returning from the cylinder is then directed on to the distribution valve situated under the hood, which then goes on to satisfy the needs of the transmission, brakes and clutch..

If the engine breaks down or the hydraulic pump fails, the Orbitrol acts as a manual pump, so that steering control is maintained at all times.

#### Operation

The Orbitrol unit consists of spool and sleeve with neutralising springs and a drive pin which connects to the cardan shaft. The cardan shaft is in turn connected to the metering unit. The Orbitrol unit has 4 hydraulic connections :

- pressure,
- returns (to distribution valve)
- 2 service ports for the steering ram.

The steering system is protected by a relief valve and 2 shock valves with suction valves.

#### Parts list

- (1) Screw
- /2\ Screw
- (3) Seal
- (4) Cover plate
- (5) O-ring
- (6) Stator
- /7\ Pin
- (8) O-ring
- (9) Rotor (metering valve)
- (10) Spacer
- (11) Cardan shaft
- /12\ Washer
- /13\ Centring springs
- (14) Needle roller bearing
- (15) Kin-ring
- (16) Washer
- (17) O-ring
- (18) Relief valve
- /19\ Seal
- (20) Shock valves
- (21) Orbitrol
- (22) Non return valve
- (23) Suction valves
- /24\ Ring
- (25) Spool valve
- (26) Check valve
- (27) Sleeve
- (28) O-ring
- (29) Distributor plate



**Hydraulics - Hydrostatic steering**

Overall view

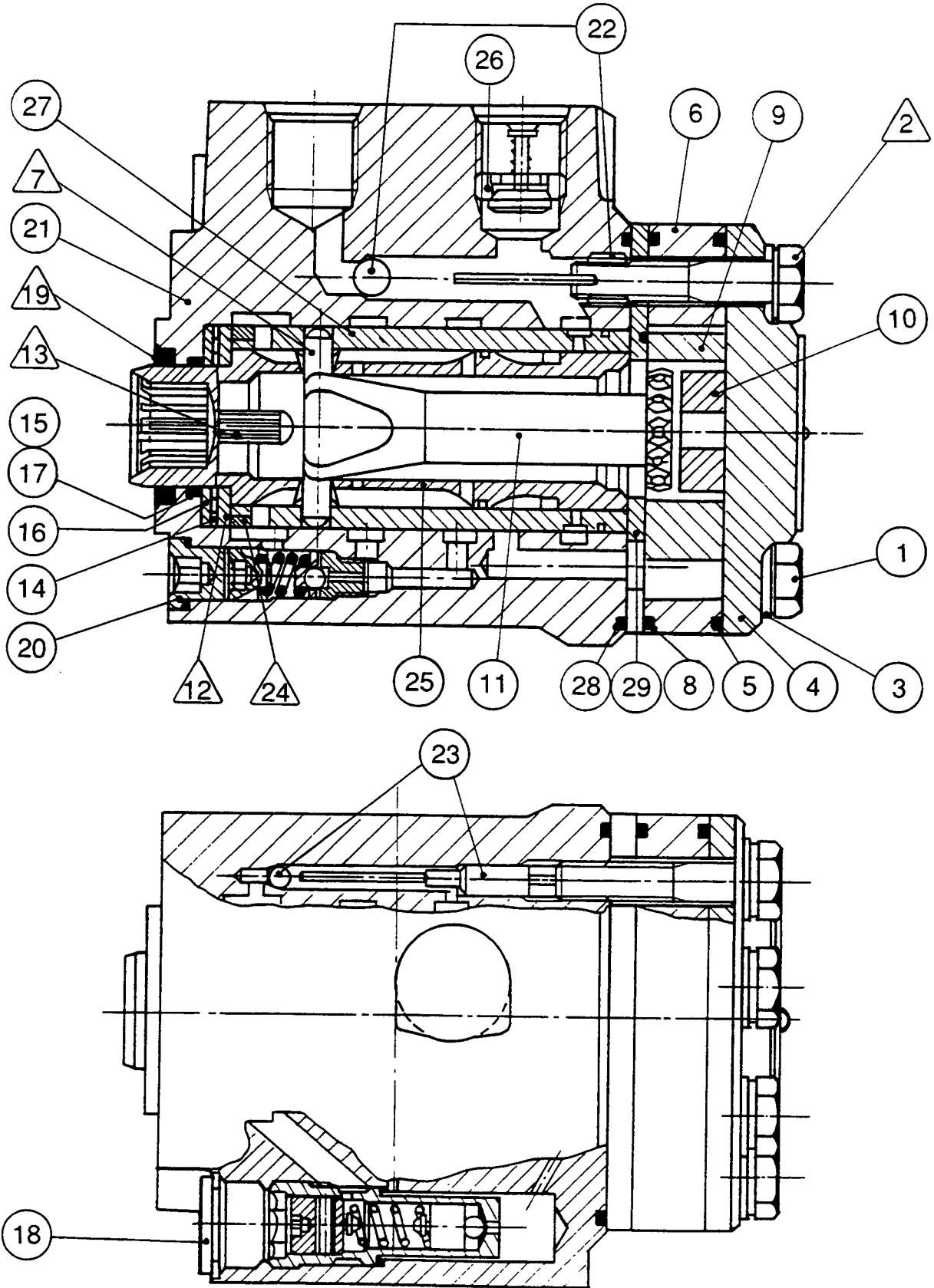





9E01.4

## 6100 SERIES TRACTORS

**Hydraulics - Hydrostatic steering****A. Neutral position (engine running)**

In the neutral position, holes in the spool (25) line up with holes in the sleeve (27). Oil from the low flow pump is directed through the open centre of the valve to the returns port and to the distribution valve. There is no oil supply to ports P1 - L and R.

The hydraulic lines to the ram cylinder are isolated. Two shock valves (20) and two suction valves (23) are fitted internally to the left and right outlet ports. The shock valves protect the system between the steering ram

and the orbitrol unit from excessive pressure, such as when the wheels hit an obstruction when the steering is in neutral. The suction valves allow the other side of the system to compensate for any oil that is released by the shock valves.

A check valve (26) is fitted in the oil feed port of the orbitrol unit. This is a one-way valve to prevent peak induced pressures that can be generated by the road wheels bearing passed to pump when steering.

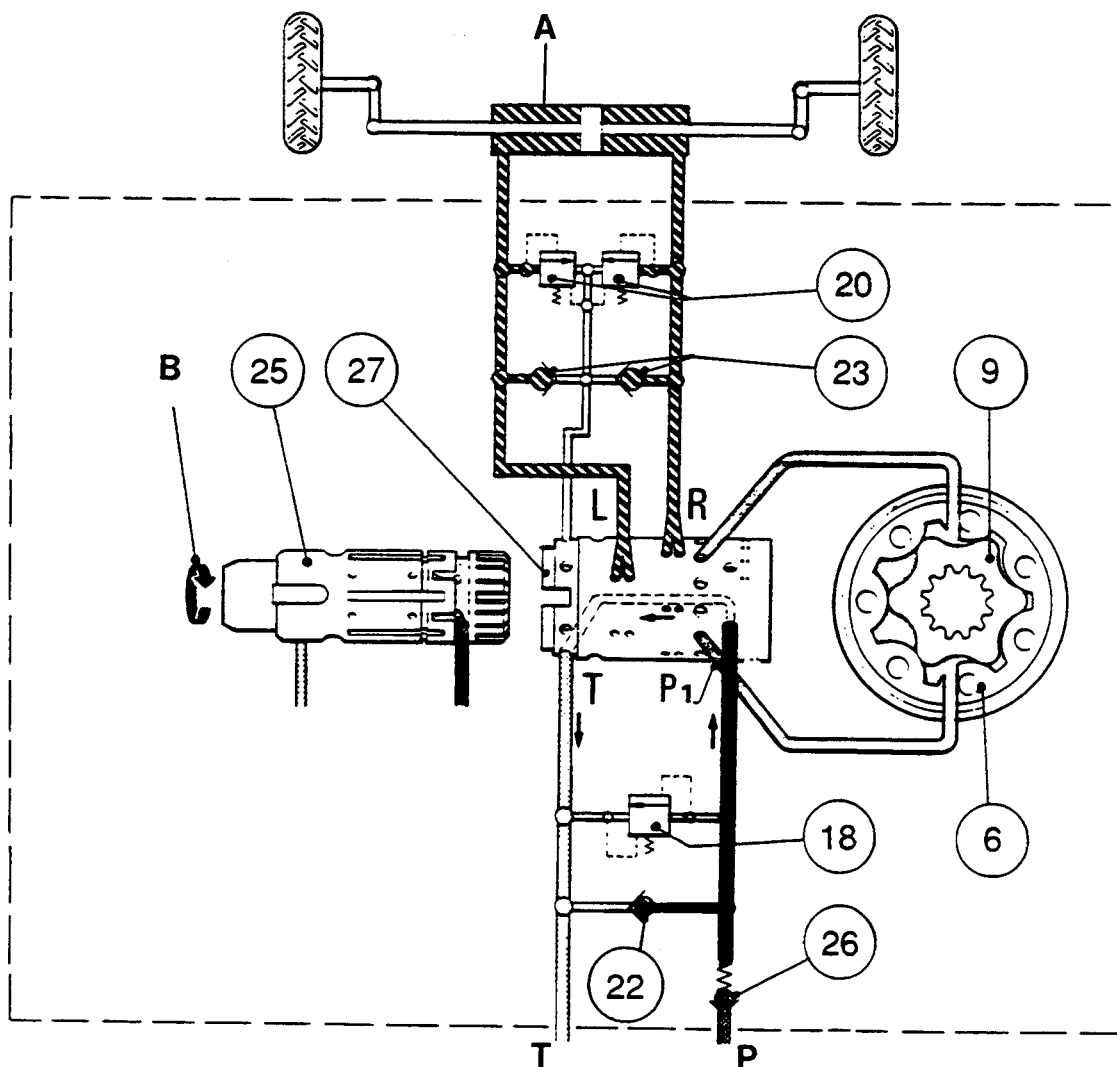

- A** Steering cylinder
- B** Position of steering wheel, left or right
- L** Supply to the left hand side of the steering cylinder
- P** Low-flow supply coming from the hydraulic pump

- P1** Supply to the metering valve (stator (6) and rotor (9))
- R** Supply to the right hand side of the steering cylinder
- T** Supply to the distribution valve



## Hydraulics - Hydrostatic steering

9E01.5

### B . Wheel turning (engine running)

The first movement of the steering wheel moves the spool (25) against the leaf springs (13). This closes the neutral ports and aligns slots in the spool with holes in the sleeve allowing oil to pass to the metering unit (stator (6) and rotor (9)). Further movement of the steering wheel continues to turn spool, sleeve and metering unit. Simultaneously the metering unit controls the oil flow and directs it back into the sleeve and spool. The oil re-entering is then directed by slots in the spool which align with holes in the sleeve to direct the oil to the left or right side of the «balanced action» steering ram. The oil returning from the steering ram is directed, by the slots in the spool valve which align with the holes in the sleeve, to the returns port which leads to the distribution valve.

Should the pressure within the steering system exceed 160 bar (2322 lbf/in<sup>2</sup>), the relief valve (18) situated in the Orbitrol unit will relieve the excess pressure. When the relief valve is actuated for example when the steering wheels are at full lock or against an obstruction, the oil which is released goes out to the returns port.

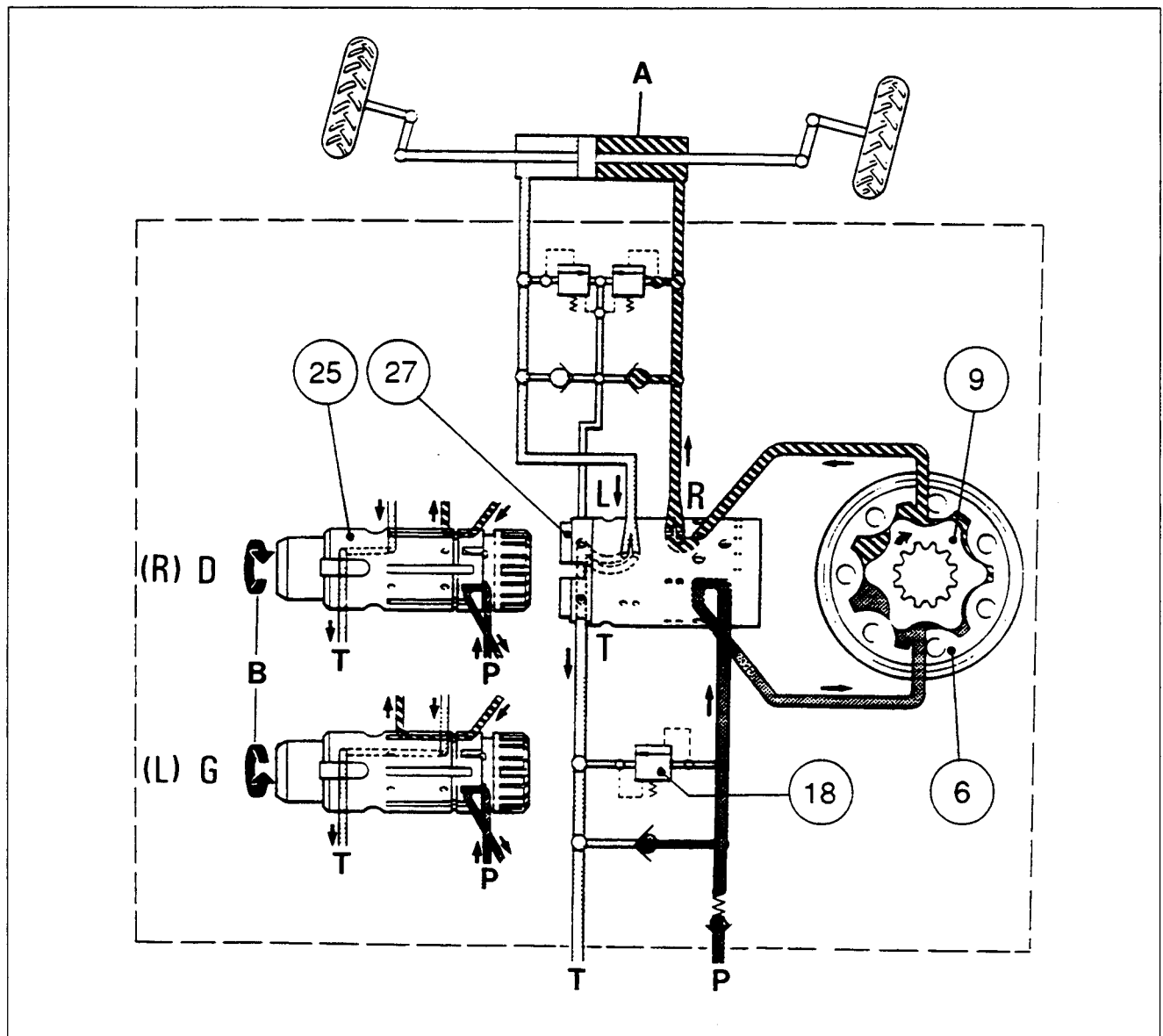



9E01.6

# Hydraulics - Hydrostatic steering

## C . Manual steering (engine stopped)

Should the pressure from the hydraulic pump cease, it is important that steering should still be maintained. For this reason, a non-return valve (22) is situated between the inlet and return galleries inside the orbitrol assembly.

When the hydraulic pump is functioning normally, the non-return valve is held on its seat by the oil pressure, allowing the oil to pass into the spool and sleeve valves.

When the pressure from the hydraulic pump drops, the oil returning from the steering cylinder «A» is allowed to pass through the non-return valve to the inlet side of the spool valve, enabling oil to be passed from one side of the steering cylinder to the other. In this way steering control is maintained at all times. The pressure generated is proportional to the torque exerted on the steering wheel.

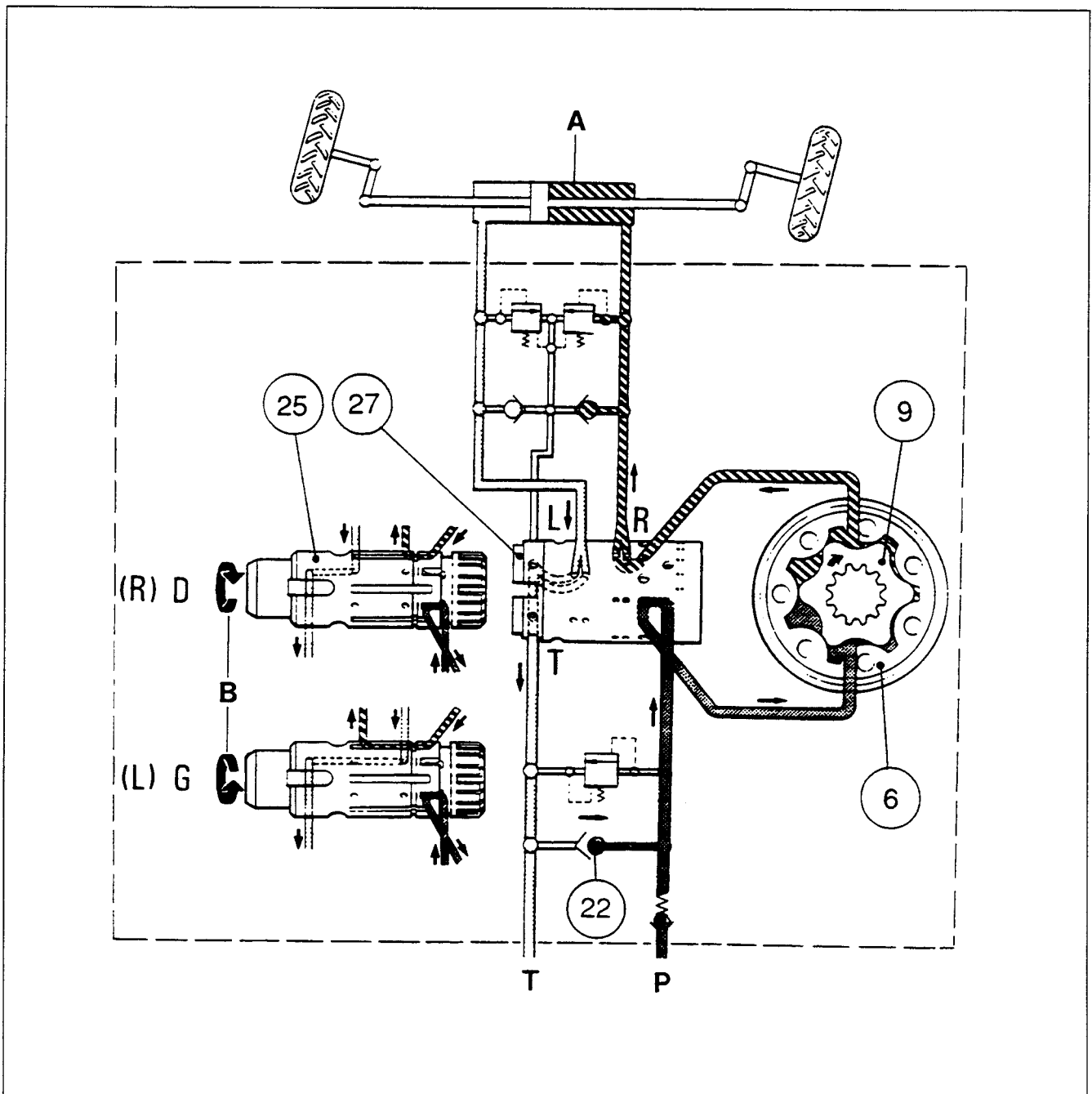



6100 SERIES TRACTORS



9E01.7

**Hydraulics - Hydrostatic steering**

Exploded view

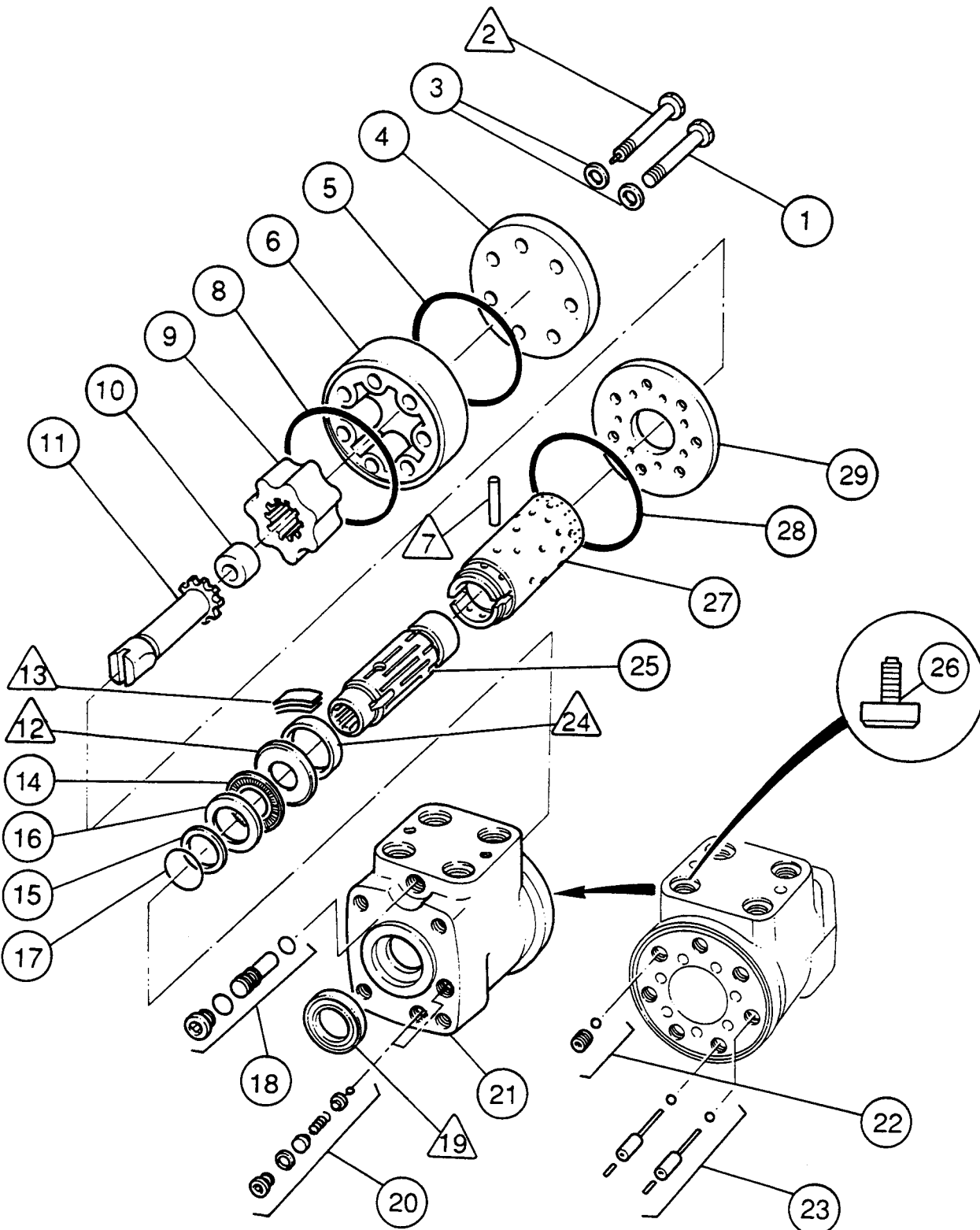



9E01.8

## 6100 SERIES TRACTORS

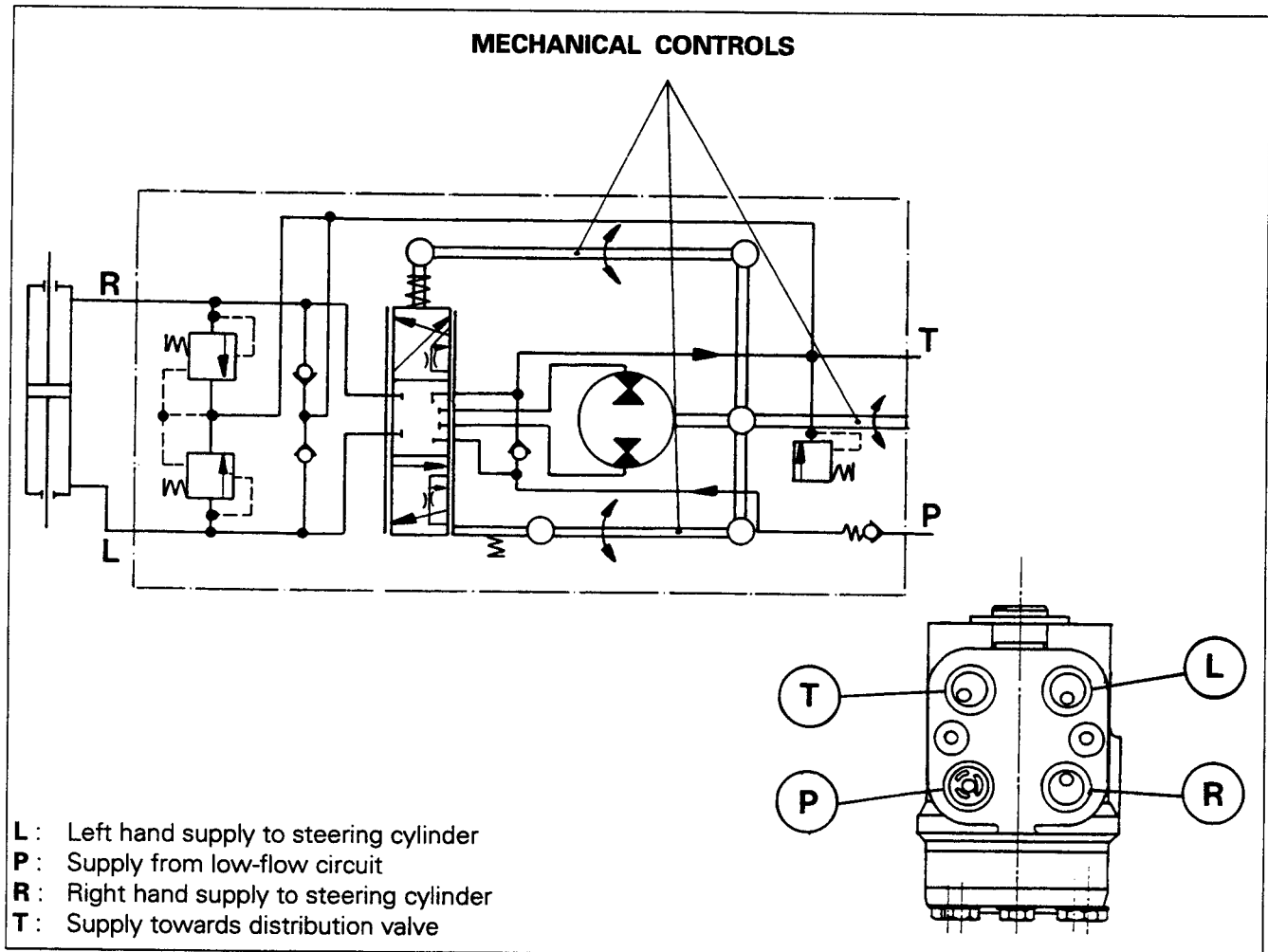
**Hydraulics - Hydrostatic steering**

## D. Disassembly and reassembly of the steering unit (Orbitrol)

### Disassembly

1. Remove the unit from the tractor.
2. Place the unit in a vice with plastic grips.
3. Remove the screws (1). Mark the position of screw (2) and remove it.
4. Remove the cover plate (4), the O-ring (5), the stator (6) and the O-ring (8).
5. Remove the spacer (10), the rotor (9), the distributor plate (29) and the O-ring (28).
6. Withdraw the connecting shaft (11).
7. Unscrew the threaded bush and recover the ball of the nonreturn valve (22).
8. Withdraw the two pins and the two balls of the suction valves (23).
9. Extract the sleeve (27) and spool valve (25) assembly by pushing it, making sure that the pin (7) is horizontal.
10. Remove the washers (12) and (16), the needle roller bearing (14) and the ring (24) of the sleeve/spool valve assembly. Remove the pin (7) and the centring springs (13) by pressing on one of their ends. Separate the sleeve (27) from the spool valve (25).
11. Unscrew the cap of the relief valve (18). Using an 8mm Allen key, remove the threaded ring and take out the seal, the spring and the valve (the crimped seat is not removable).
12. Unscrew the two caps of the shock valves (20). Remove the seals. Using a 6mm Allen key, remove the threaded rings and take out the springs, the balls and their seats (the crimped seats are not removable).
13. Take out the seal (19), the kin-ring (15) and the O-ring (17).
14. Remove the check valve (26).



## Hydraulics - Hydrostatic steering

### Reassembly

15. Check and clean the parts, replacing any which are defective. Lubricate with suitable transmission oil before reassembling.
  16. Refit the check valve (26).
  17. Using special tool MS62A, fit the seal /19\, the O-ring (17) and the kin-ring (15).
  18. In the holes for the shock valves (20) place the balls and the springs. Screw in the threaded rings. Fit the seals and tighten the caps.
  19. In the hole for the relief valve (18) place the valve and the spring. Screw in the threaded ring. Fit the seal and tighten the cap to a torque of 40-60 Nm.
  20. Fit the spool valve (25) into the sleeve (27). Position the centring springs /13\ as shown in Fig. 1 and fit the pin /7\ using special tool MS63..
  21. Position the ring /24\ on the sleeve and spool valve assembly so that the chamfer facilitates assembly in the unit.
  22. Fit the washers /12\ and (16) with the chamfer of the washer /12\ facing towards the centring springs /13\, and with the needle roller bearing (14) between them.
  23. Fit the sleeve and spool valve assembly in the unit, applying a slight oscillating movement. Ensure that the pin /7\ is held horizontally.
  24. In the receptacles of the suction valves (23) place the two balls and the two pins.
  25. In the receptacle of the non -return valve (22) place the ball and screw on the threaded ring.
  26. Position the connecting shaft (11).
  27. Fit the O-ring (28) and the distributor plate (29).
  28. Fit the rotor (9) in such a way that two of the «C» shaped hollows are in the axis of the aperture of the shaft (11) (Fig. 2). Refit the spacer (10).
  29. Place the O-rings (5) and (8) on the stator (6).
  30. Whilst taking care not to move the rotor (9), fit the stator (6). Then move the stator so that its fastening holes coincide with those of the distributor.
- Note: The rotor (9) and the pin /7\ must be in the position shown in Fig. 3.**
31. Refit the cover plate (4).
  32. Refit the screw /2\ (in the position marked upon disassembly) and the screws (1) with their seals (3). Tighten alternately to a torque of 30– 35 Nm.
  33. Using a test bench or an appropriate equipment, check the adjustment and operation of the Orbitrol.
  34. Refit the unit on the tractor.

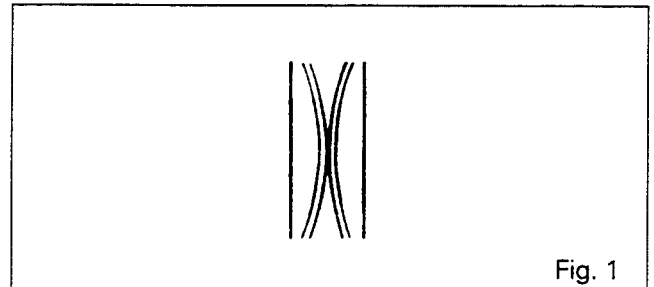

Fig. 1

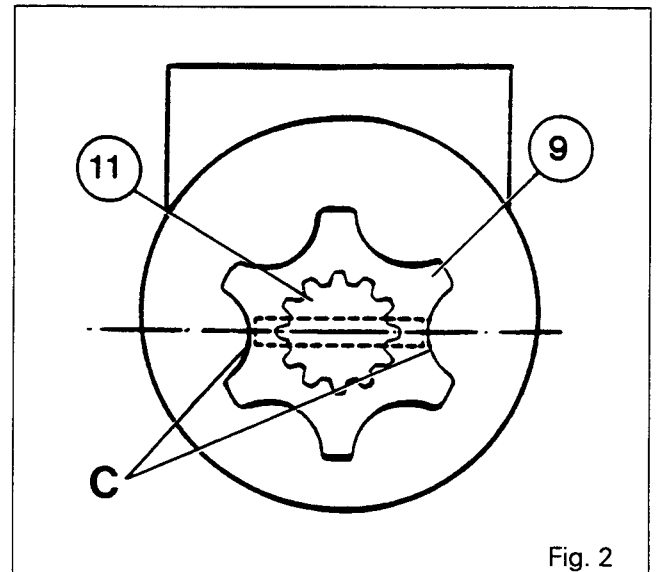

Fig. 2

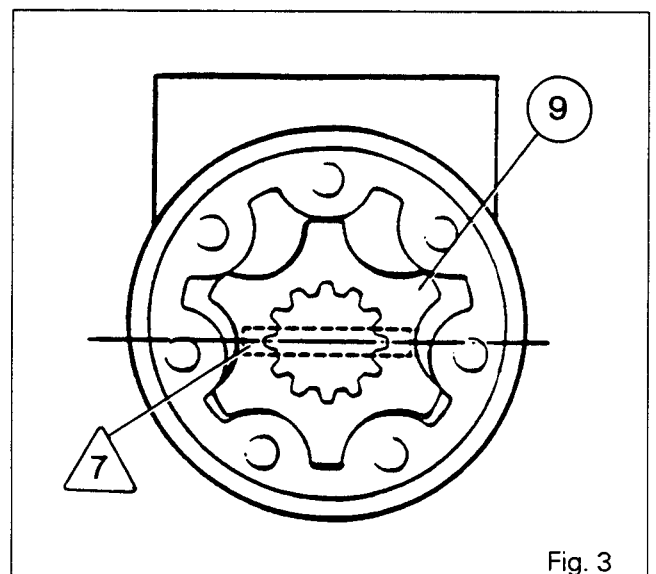

Fig. 3





**Hydraulics** - Low-pressure components

**9 F01** Low-pressure components

CONTENTS

- <b>General</b> _____	2
<b>A. Lubrication and cooling system</b> _____	2
<b>B. 1.5 bar valve</b> _____	2





9F01.2

## 6100 SERIES TRACTORS

**Hydraulics - Low-pressure components****General**

Functions or mechanisms supplied by the low-pressure system	For operation refer to section
<ul style="list-style-type: none"> <li>. The hydrostatic steering unit (Orbitrol)</li> <li>. The Speedshift or Dynashift situated in front of the gearbox</li> <li>. The main clutch control valve</li> <li>. The Dynashift control</li> <li>. The Hi/Lo (Hare/Tortoise) device fitted at the rear of the gearbox</li> <li>. The electro-hydraulic control of the reverse shuttle fitted on the selector cover</li> <li>. The front axle clutch (4WD) fitted, in the lower part of the rear axle</li> <li>. The front and rear differential lock</li> <li>. The p.t.o. clutch located at the front of the centre housing</li> <li>. The p.t.o. brake fitted at the rear of the centre housing</li> <li>. The lubrication and cooling system</li> </ul>	<p>9 E01 5 B02 - 5 B 03</p> <p>9 J01 9 K01 5 C01</p> <p>5 C02</p> <p>8 A01</p> <p>8 C01 - 6 E01 7 E01</p> <p>7 A01 5 A01</p>

**A . Lubrication and cooling system**

When the main functions of the low-pressure system have been satisfied, the oil flows through the 17 bar distribution valve **(3)** and travels towards the oil cooler **(13)**. It enters the oil cooler and passes into the lubrication line **L** (Fig. 2), connected to the 17 bar distribution valve through a unit equipped with a valve set to 0.7 bar (Fig. 3 Section 9H01) which supplies the master cylinders (residual pressure).

When the oil is cold, the 5 bar valve opens in the 17 bar distribution valve and enables a quantity of oil to pass directly into the lubrication line **L** (Fig. 3).

The main clutch is lubricated and cooled via an independent gear pump. Oil is aspirated in the centre housing and directed to the clutch via a pipe and a strainer fitted under the transmission.

**B . 1.5 bar valve**

The lubrication line has a valve situated at the front left of the gearbox which maintains a pressure of 1.5 bar in the circuit.

**Operation**

The flow of oil coming from the 17 bar distribution valve lubricates the front cover and the gearbox as well as the PTO shaft which traverses it.

An external pipe also brings the oil to the PTO clutch. A small-bore pipe directs the oil towards the driving pinion of the PTO upper shaft and the coupler as well as the compound pinion of the 4-speed PTO (if fitted).

If the pressure is greater than 1.5 bar, the spring **(2)** is compressed, the valve **(1)** lifts up and the oil flows into the gearbox housing (Fig. 1).

**Legend (Fig. 2/3)****(3)** 17 bar distribution valve**(13)** Oil cooler**(36)** 1.5 bar valve**A** Front PTO lubrication (if fitted)**B** Lubrication hose coming from the 17 bar distribution valve**C** Lubrication of front cover PTO shaft and gearbox**D** Lubrication of PTO clutch**E** Lubrication of driving pinion of PTO and coupler as well as compound pinion (4-speed version)**L** Lubrication line

Fig. 1



**Hydraulics - Low-pressure components**

9F01.3

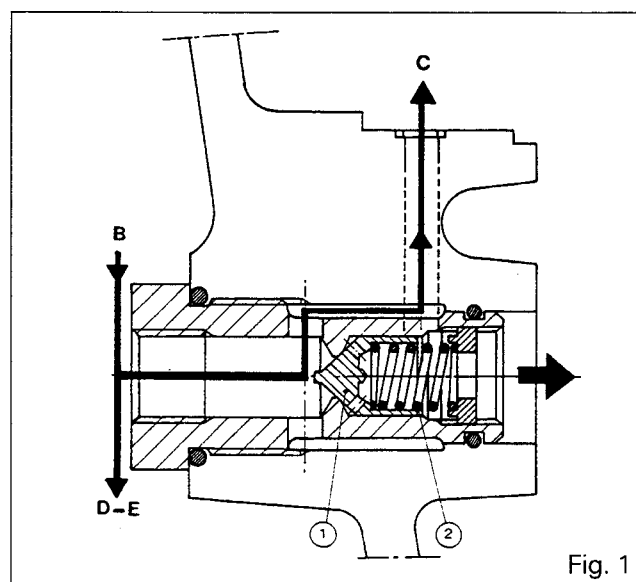
**Lubrication and cooling system, 1.5 bar valve closed (oil hot)**

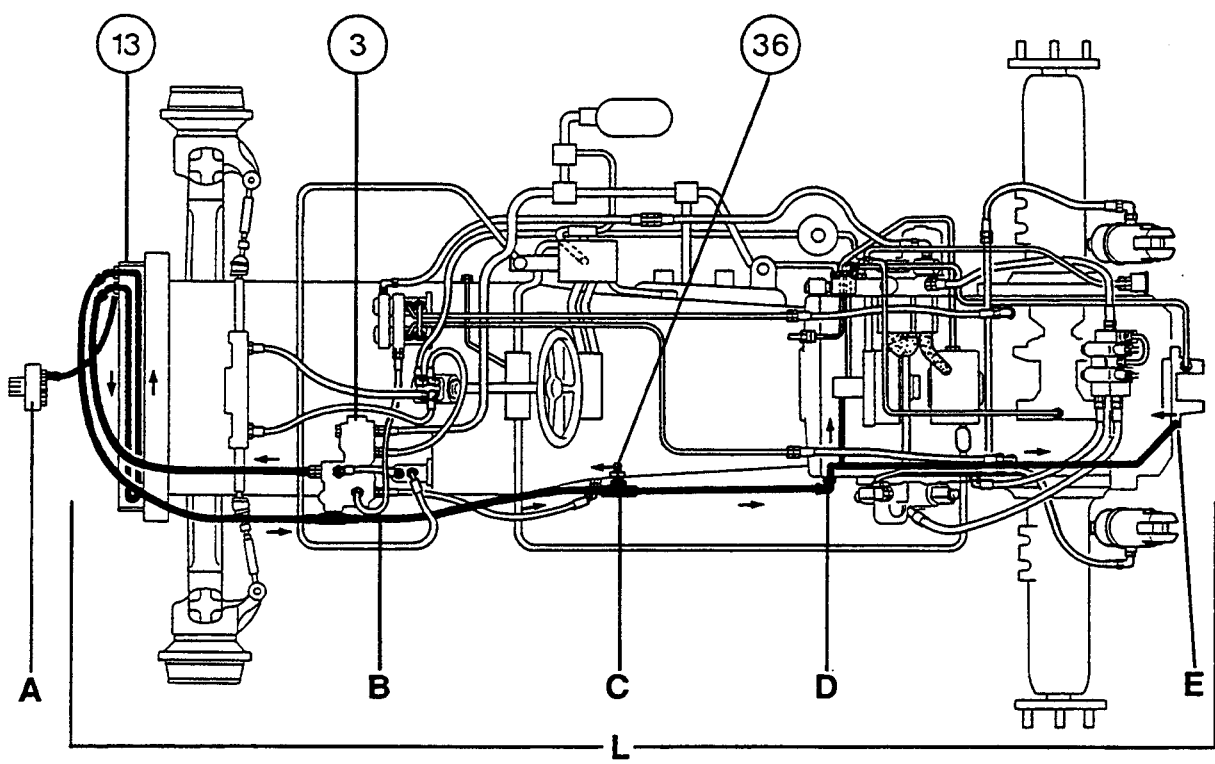

Fig. 2

**Lubrication system, 1.5 bar valve opened (oil cold)**

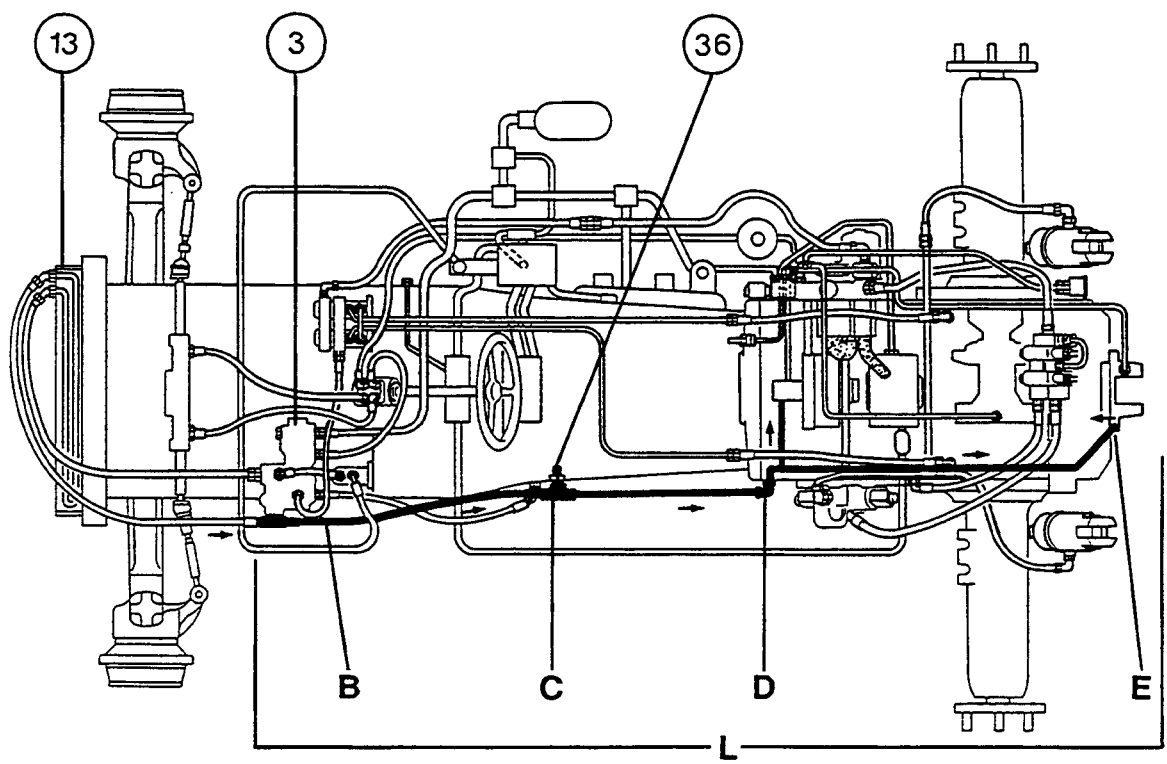

Fig. 3





*9 G01 Brake and clutch master cylinder circuit*

CONTENTS

<b>A.</b>	<b>Working on the master cylinders</b> _____	<b>2</b>
<b>B.</b>	<b>Master cylinders with trailer brake</b> _____	<b>2</b>
<b>C.</b>	<b>Master cylinders without trailer brake</b> _____	<b>4</b>
<b>D.</b>	<b>Brake pedal adjustment</b> _____	<b>5</b>
<b>E.</b>	<b>Clutch master cylinder</b> _____	<b>6</b>
<b>F.</b>	<b>Clutch pedal adjustment</b> _____	<b>6</b>



9G01.2

## 6100 SERIES TRACTORS

**Hydraulics - Master cylinders****A. Working on the brake and clutch master cylinders**

If it should prove necessary to dismantle the master cylinders, clean all parts carefully. Replace those which are scratched or deformed.

Brake and clutch master cylinder repair kits can be found in the spare parts catalogue.

After disassembly or replacement of the brake master cylinders, bleed the main brake circuit and the trailer brake circuit (if fitted). Refer to section 6F01 (§ C and D). Check brake pedals adjustment (§ D).

After disassembly or replacement of the clutch master cylinder, bleed the circuit, refer to sections 4 A01 or 4 B01 according version. Check clutch pedal adjustment.

**B. Master cylinders with trailer brake (dual circuit) (Fig. 2)****Pedals unlatched (Fig. 1)**

The effort applied to a pedal, transmitted by the rod (5), moves the piston (4) in the bore of the active master cylinder. The valve (1) closes the feed port, the balancing valve (3) is opened by the piston (4) and the ball (2) and oil is fed under pressure to the ports of the main brake C and of the pressure balancing junction D.

Through the junction, the pressure closes the valve (3) of the passive master cylinder.

The action on the piston (4) likewise causes the movement of the piston (6) and the closure of the valve F. The oil contained in the chamber E is channelled via the connecting bar to the chamber E' and to the orifice B' through the open valve F' of the passive master cylinder.

The assembly comprising the valve F and the piston (6) rapidly meets the end of the active master cylinder. In this position, only the tractor brake is activated.

The trailer is not braked.

**Pedals latched****Braking and balancing of pressure**

The effort applied to both pedals, transmitted by the push rods (5), moves the pistons (4) in the bores of the two master cylinders. The two valves (1) close the feed ports, the two balancing valves (3) are opened by the pistons (4) and the balls (2). The pressure equalizes in the two master cylinders by the balancing junction D. The oil is likewise fed under pressure to the ports C and C' of the main brake circuit.

**Trailer braking**

The continuous action of the pistons (4) and (6) closes the valves F and F'. The chambers E and E' which are pressured feed the control valve of the trailer brake via the ports A and A'.

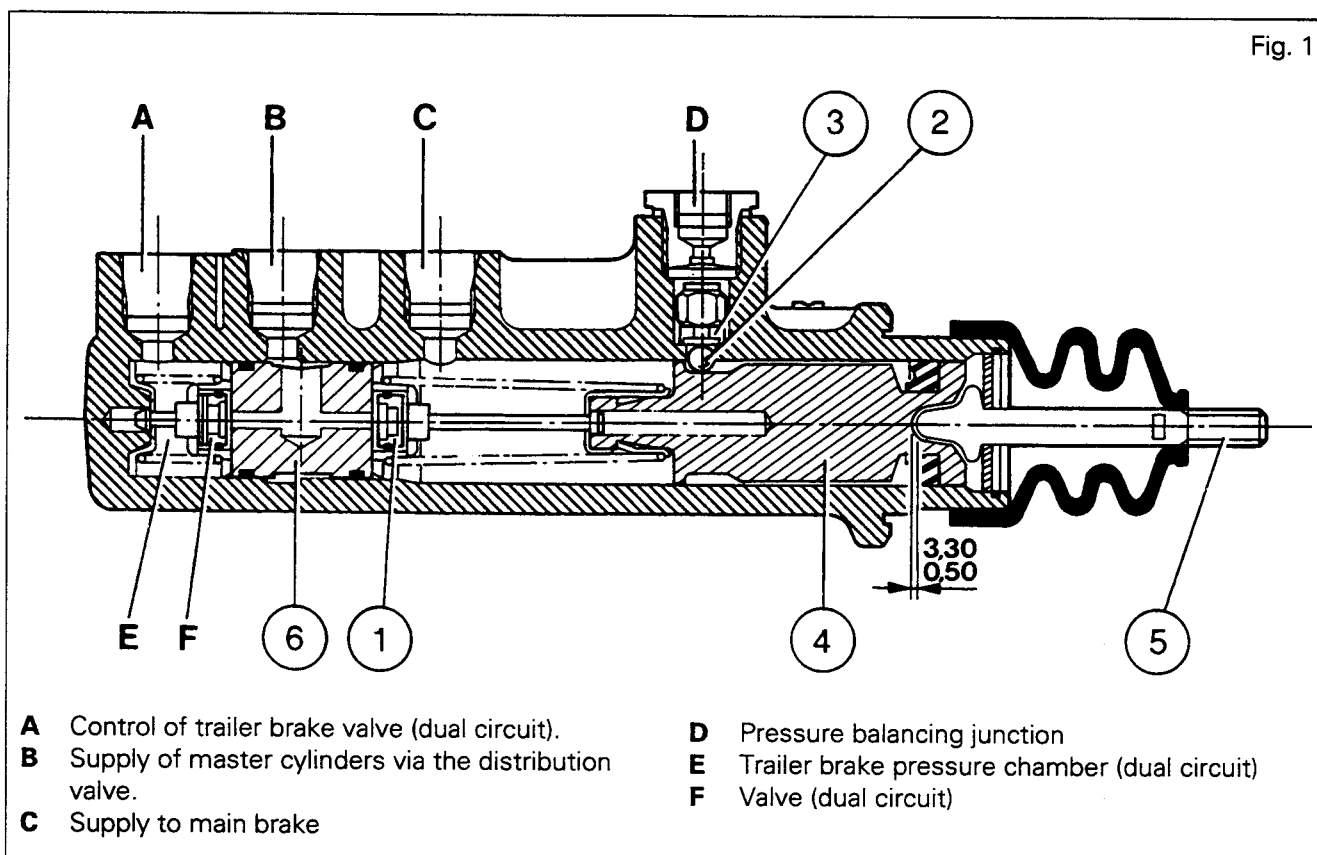

Fig. 1

**Brake master cylinders with trailer braking (dual circuit)**

Fig. 2

**Brake master cylinders with trailer braking (single circuit)**

- (1) Bar (control of trailer brake valve)
- (2) Bar (supply of master cylinders, coming from the distribution valve)
- (3) Main brake supply
- (4) Pressure balancing junction pipe
- (5) Brake master cylinders

- (6) Trailer brake sensing pipe
- (7) Trailer brake valve
- (8) Trailer brake junction
- (9) Sensing pipe (single-circuit version with trailer brake)

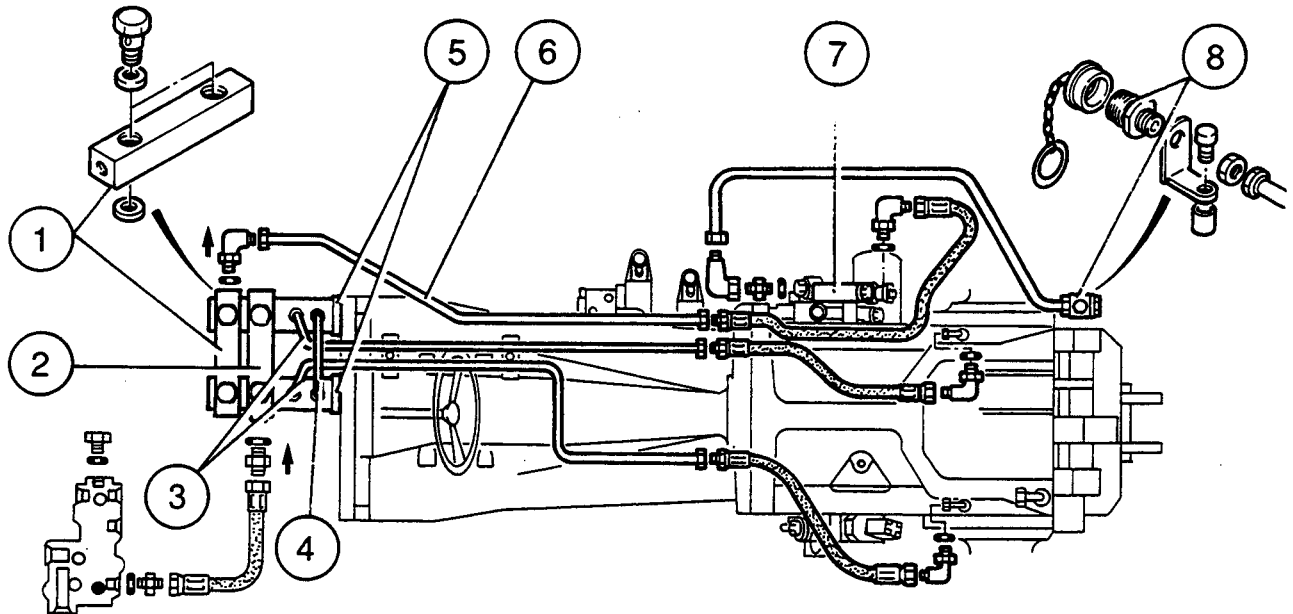
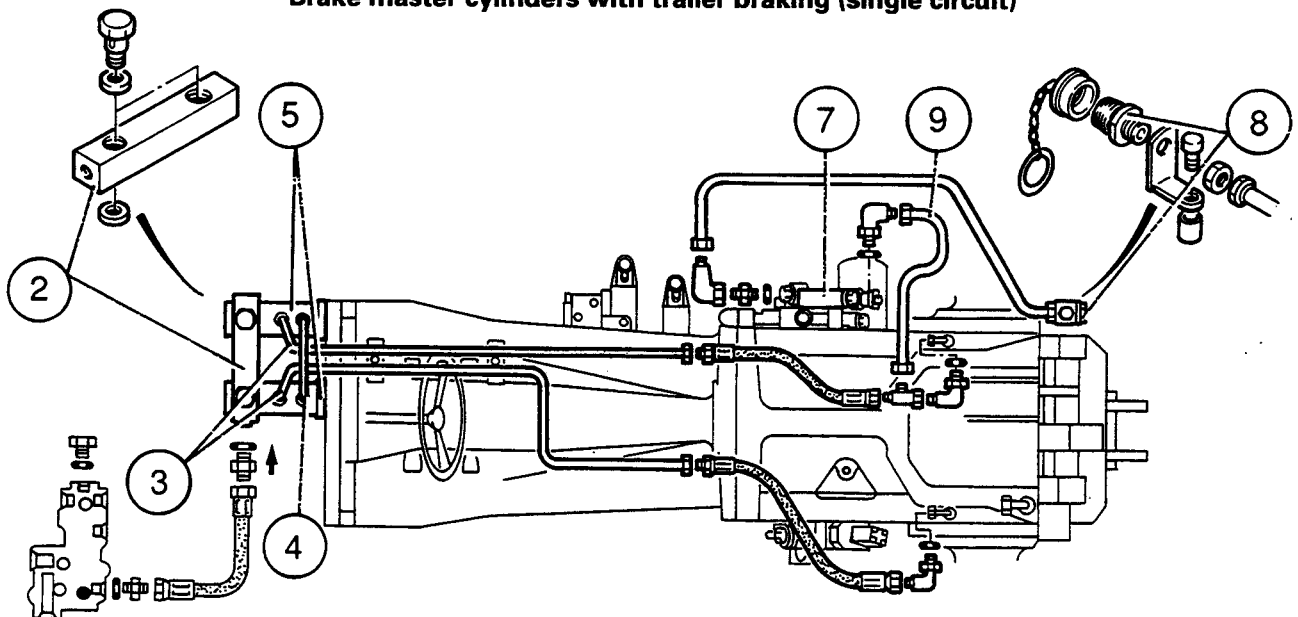
Fig. 3



9G01.4

## 6100 SERIES TRACTORS

**Hydraulics - Master cylinders****C. Master cylinders without trailer brake (single circuit) (Fig. 6)****Pedals unlatched (Fig. 4)**

The effort applied to a pedal, transmitted by the rod (5), moves the piston (4) in the bore of the active master cylinder. The valve (1) closes the feed port, the balancing valve (3) is opened by the piston (4) and the ball (2) and the oil is fed under pressure to the ports of the main brake C and of the pressure balancing junction D. Through the balancing junction, the pressure closes the valve (3) of the passive master cylinder.

**Pedals latched****Braking and balancing of pressure**

The effort applied to the two pedals, transmitted by the rods (5), moves the pistons (4) in the bores of the two master cylinders. The two valves (1) close the feed ports, the two balancing valves (3) are opened by the pistons (4) and the balls (2).

The pressures equalize in the two master cylinders by the balancing junction D. The oil is likewise fed under pressure to the ports C and C' of the main brake circuit.

**Note:** There is a version with trailer brake (Fig. 3) for tractors equipped with a single-circuit assembly. The trailer brake valve (7) is controlled by a pipe (9) connected to the feed hose (3) of the right hand-brake, on the upper part of the rear axle housing (Fig. 5).

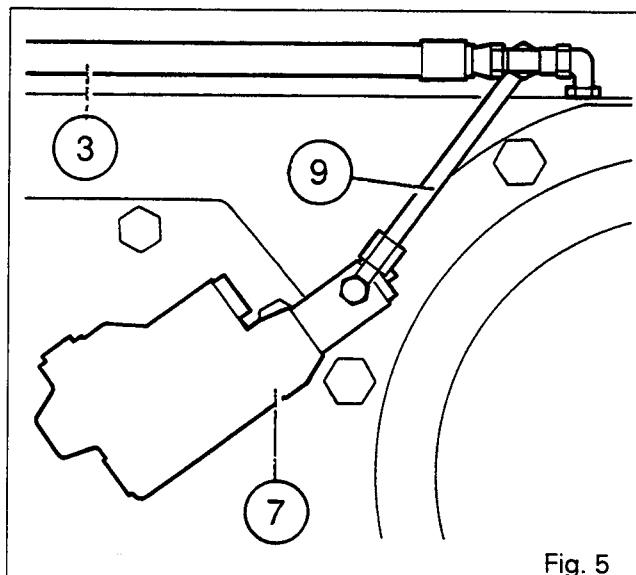
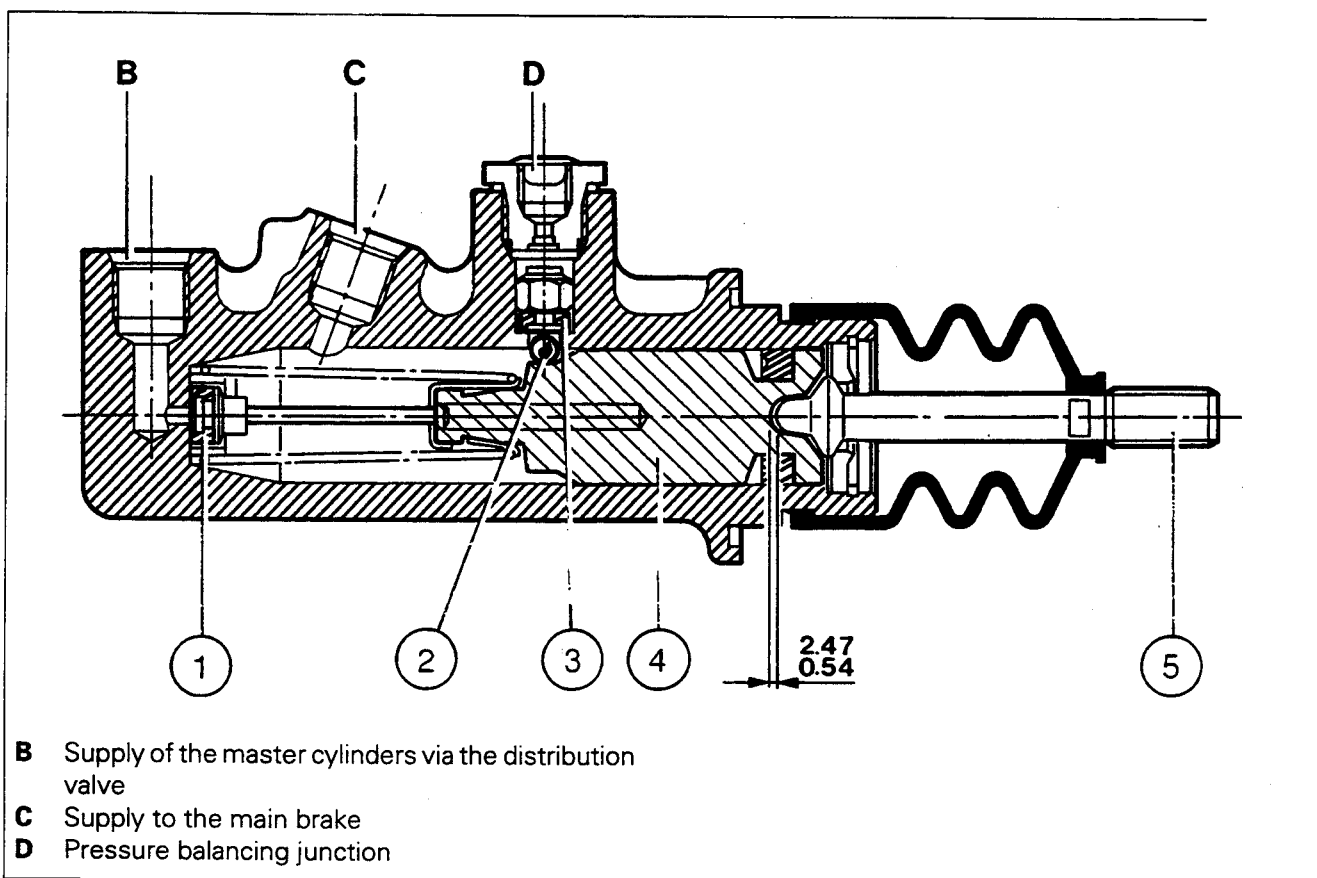

Fig. 5





## Hydraulics - Master cylinders

### Brake master cylinders without trailer braking (single circuit)

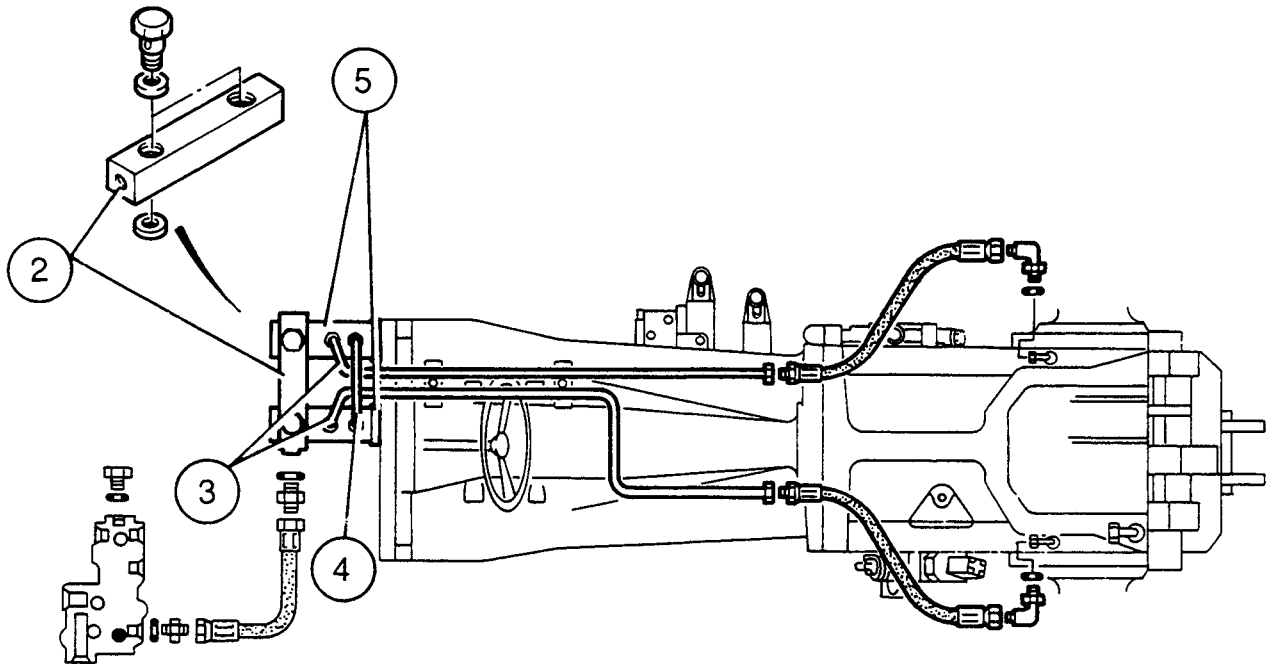

- (2) Bar (supply of master cylinders, coming from the distribution valve)  
 (3) Main brake supply

- (4) Pressure balancing junction pipe  
 (5) Brake master cylinders

Fig. 6

### D. Brake pedal adjustment

1. Smear the pins (5) and (6) with molybdenum disulphide (Fig. 7).
2. Smear the clevis (1) with Loctite 542 and screw it on to the rod (2).
3. Fit the return spring (3).
4. Adjust the clevis so as to obtain a distance X of  $115 \text{ mm} \pm 0.5$  between the support (4) and the clevis fastening pin.
5. Do the same for the second clevis and check that the twinning mechanism operates smoothly.
6. Manually check the operation of each pedal to ensure that they operate freely.

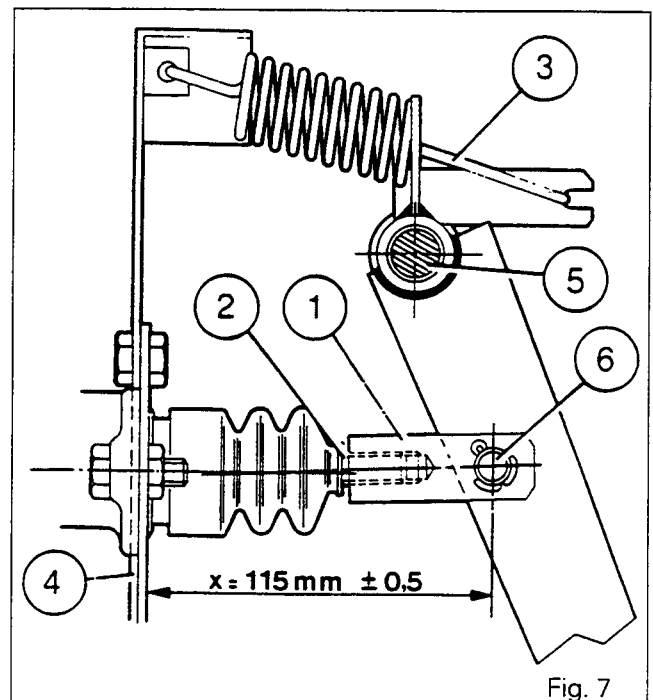

Fig. 7





9G01.6

# Hydraulics - Master cylinders

## E. Clutch master cylinder

### Operation (Fig. 10)

The effort applied to the pedal, transmitted by the rod (1), moves the piston (2) in the bore of the master cylinder. The valve (3) closes the feed port A and the oil is fed under pressure to the port B and the supply channel of the clutch slave cylinder.

**Note : For sealing improvement two guide rings have been added to the piston from serial n°R334024.**

**Only complete master cylinder are interchangeable, not the repair kits.**

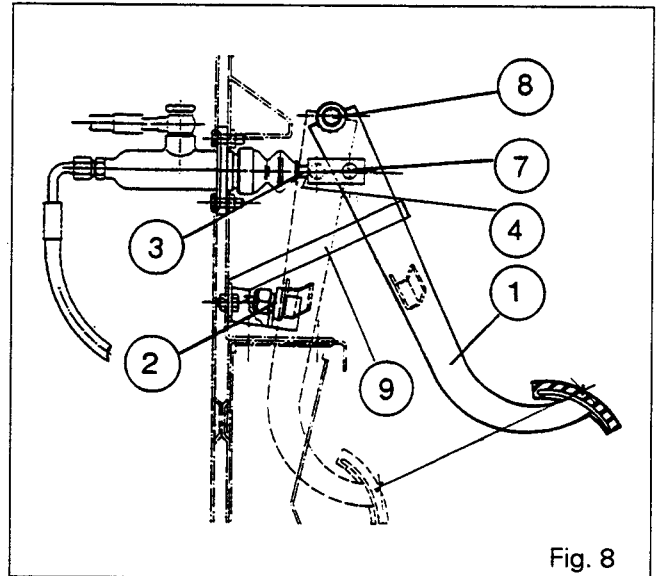

Fig. 8

## F. Clutch pedal adjustment

1. Coat the pins (3) and (4) with molybdenum disulphide.
2. Apply Loctite 542 on thread of the rod (1).
3. Adjust the rod so as to obtain travel of :
  - 150 mm : pressure loaded (Fig. 8)
  - 200 mm : spring loaded (Fig. 9)
 between the declutched position (pedal in contact with the stop (2)) and the engaged position.
4. Manually check the operation of the pedal to ensure that it operates freely.

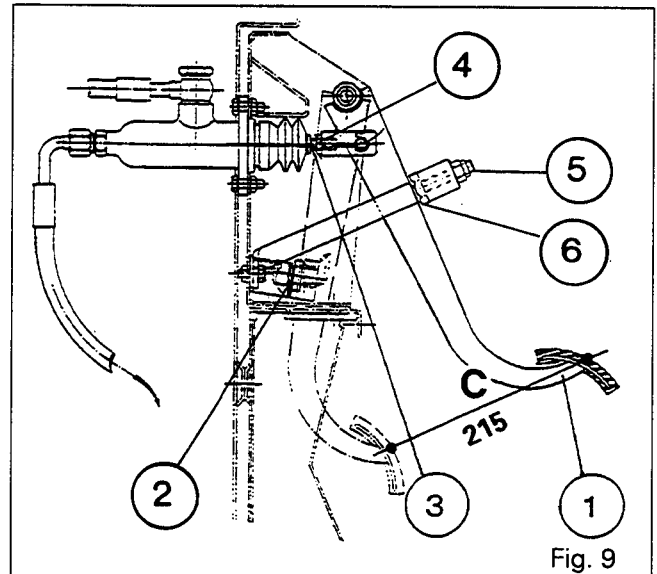

Fig. 9

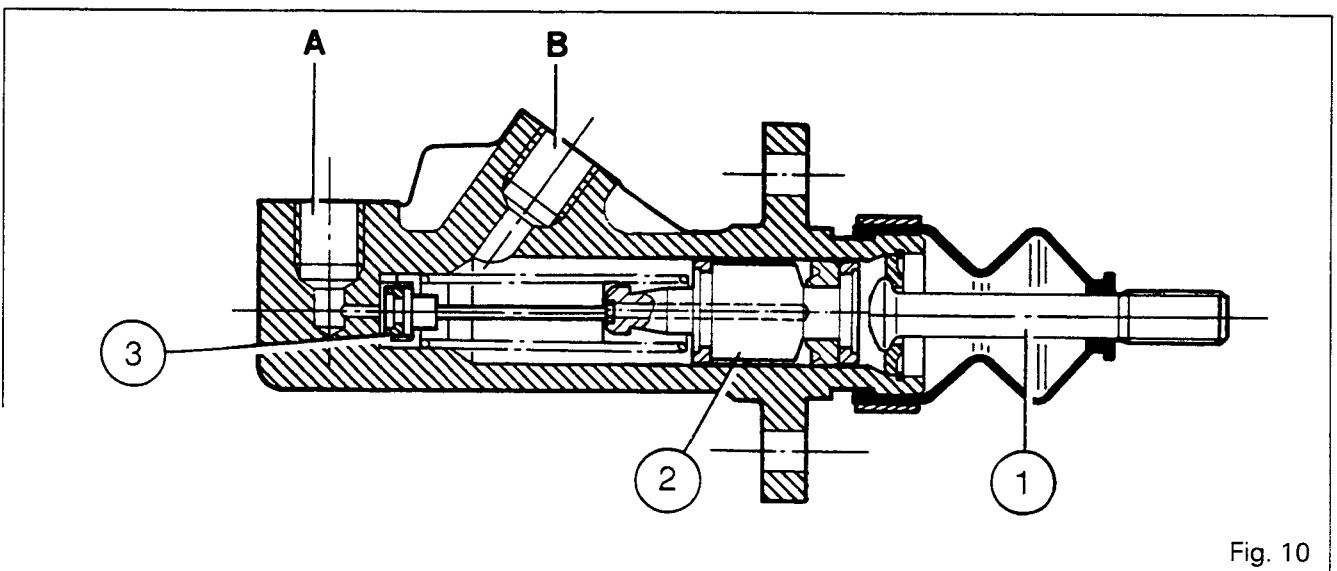

Fig. 10



**Hydraulics** - *Distribution valve*

9 H01 *Distribution valve*

CONTENTS

- <b>General</b> .....	2
<b>A. Operation</b> .....	2



9H01.2

## 6100 SERIES TRACTORS

**Hydraulics - Distribution valve****General**

The distribution valve is fitted on the rear bonnet support. Its function is:

- To supply oil and keep the low pressure circuit to 17 bar.
- To supply the lubrication and cooling system.
- To ensure a constant level in the brake and clutch master cylinders.

As from serial numbers D086001 (6100 standard) and D115017 (6100 steep nose), a valve limits the residual pressure to the master cylinders (see Fig. 13).

**A. Operation (Fig. 2)**

When the engine is started, the oil coming from the steering control valve (Orbitrol) enters through port **1** and flows out through port **5** towards the low pressure circuit of the right hand hydraulic cover to feed :

- the input unit Speedshift or Dynashift
- the engine clutch (Pressure loaded)
- the electro-hydraulic reverse shuttle control
- the Hare/Tortoise range
- the 4WD clutch
- the differential lock
- the p.t.o. clutch
- the p.t.o. brake
- the front p.t.o. (if fitted)

A back pressure is then created in the circuit, forcing the ball (**20**) to lift from its seat, compressing the spring (**21**). The oil passes to the back of the spool (**19**), creating a pressure which gradually moves it, compressing the spring (**17**), resting against the shims [**18**].

The spool (**19**) enables the oil to pass towards the port **6** and towards the oil cooler. It emerges cooled and travels towards the channels (**14**) and (**13**) of the lubrication system. When the oil is cool, the 5 bar valve (**15**) opens and allows a quantity of oil to pass directly to the channel (**13**) of the lubrication system without passing through the cooler.

When one of the low-pressure functions is required, the momentary pressure drop causes the ball (**20**) to return to its seat due to the action of the spring (**21**), and the spool (**19**) attempts to move, being pushed back by its own spring (**17**). The oil in the end chamber escapes through the drain hole V, enabling the spool to move back slowly.

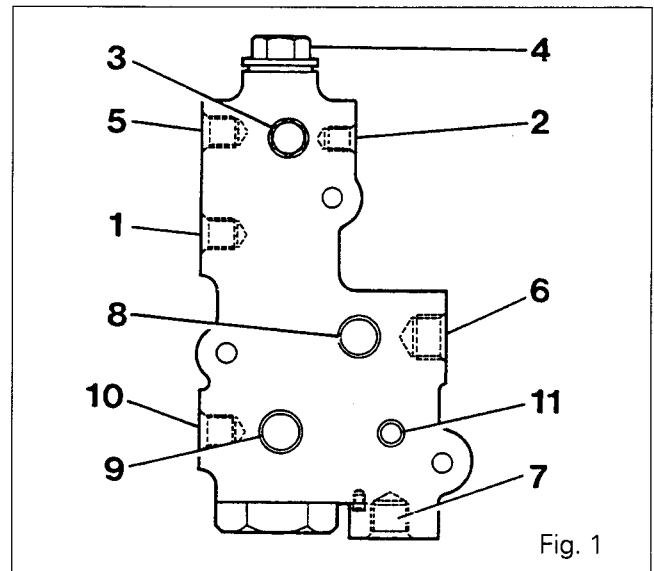

Fig. 1

When the needs of the low-pressure circuit are satisfied, the oil finally passes through the feed ports **8** and **10** (Fig. 1). Flow and residual pressure are regulated by a pipe **11** and a restrictor **A**, thereby maintaining a constant level in the brake and clutch master cylinders. Leakages return to the gearbox via port **9**.

**Note: After dismantling or replacement of the valve, tighten it to a torque of 40 to 55 Nm.**

**Designation of ports (Fig. 1).**

Each port is numbered on the valve body.

- 1** Supply coming from the Orbitrol unit.
- 2** Outlet to the front p.t.o. (if fitted).
- 3** Not used (plug)
- 4** Not used (plug)
- 5** Outlet (17 bar) to the Speedshift or Dynashift, the electro-hydraulic reverse shuttle control and the solenoids fastened on the right hand cover.
- 6** Outlet to the oil cooler (5 bar valve closed).
- 7** Outlet to the lubrication line (5 bar valve open).
- 8** Clutch master cylinder supply (residual flow).
- 9** Return to front left hand of gearbox.
- 10** Brake master cylinder supply (residual flow).
- 11** Outlet with external pipe connecting the supply channels of the brake and clutch master cylinders and the T-piece mounted on the outlet **7** of the lubrication line.

**Hydraulics - Distribution valve**

9H01.3

Fig. 2

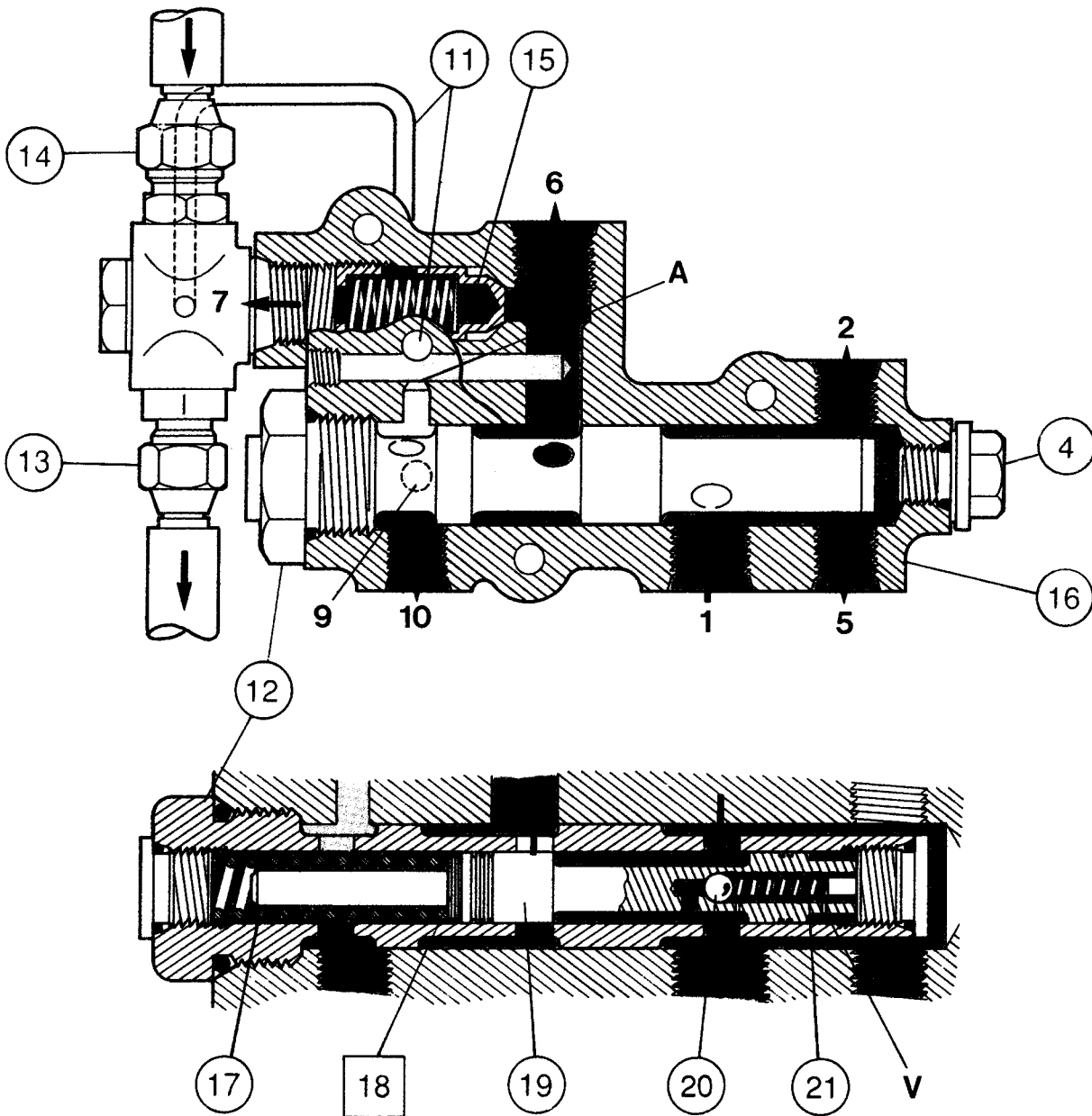

- |      |  |      |            |
|------|--|------|------------|
| (12) | Distribution valve   | (17) | Spring     |
| (13) | Lubrication towards the front cover, the p.t.o. shaft, the p.t.o clutch and the driving gear 2 or 4-speed p.t.o. | (18) | Shims      |
| (14) | Lubrication coming from the oil cooler (5 bar valve closed)  | (19) | Spool      |
| (15) | 5 bar valve  | (20) | Ball       |
| (16) | Valve body   | (21) | Spring     |
|      |  | A    | Restrictor |
|      |  | V    | Drain hole |



9H01.4

## 6100 SERIES TRACTORS

**Hydraulics - Distribution valve****Unit with valve (23) Fig. 3**

As from serial numbers D086001 (6100 standard) and D115017 (6100 steep nose), the 17 bar distribution valve is equipped with a unit (22) fitted between the hoses (13) - (14).

Fitted to the back of the unit, the valve (23) ensures the supply, through the pipe (11), of clutch and brake master cylinders under a residual pressure of 0.7 bar. A second hose (24) connected to the unit, returns the oil to the front left of the gearbox housing.

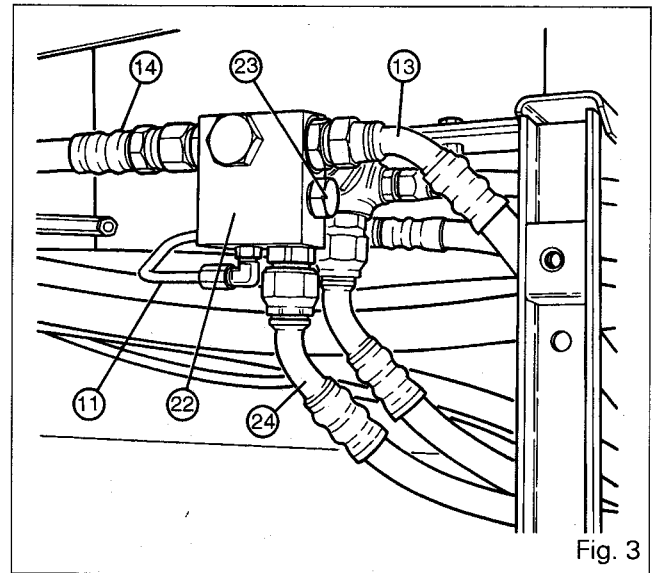



## **Hydraulics** - RH hydraulic cover

### 9 101 Right-hand hydraulic cover

#### CONTENTS

-	<b>General</b> _____	<b>2</b>
A.	<b>Removal of cover</b> _____	<b>7</b>
B.	<b>Refitting of cover</b> _____	<b>8</b>
C.	<b>Disassembly and reassembly of high-pressure valve</b> ____	<b>9</b>
D.	<b>Disassembly of cover</b> _____	<b>9</b>
E.	<b>Removal and disassembly of pump</b> _____	<b>11</b>
F.	<b>Reassembly and refitting of pump</b> _____	<b>12</b>
G.	<b>Reassembly of cover</b> _____	<b>14</b>



9101.2

## 6100 SERIES TRACTORS



# Hydraulics - RH hydraulic cover

### General

The right-hand cover fitted on the rear axle housing has two main functions:

- It serves as a support for numerous components of the hydraulic system.
- It comprises various intake and delivery channels of the high- and low-flow (high- and low-pressure) circuits.

The internal face of the cover accommodates:

- The dual element hydraulic pump and its driving gear.
- The suction pipe.
- The intake manifold.
- The transfer pipe from the left cover.

Its external faces accommodate:

- The five solenoids controlling the low-pressure functions (depending on option).
- The safety valve of the high-pressure circuit.
- The trailer brake valve (if fitted) or a cover plate.
- The pressure test coupler.
- The strainer.
- The main filter with its support.
- The low oil pressure switch.
- The filter vacuum switch.
- The engine speed sensor.

### Parts list

- |   |  |
|---|--|
| <ul style="list-style-type: none"> <li>(1) Cover</li> <li>(2) Screw</li> <li>(3) High-pressure (high-flow) valve</li> <li>(4) Engine speed sensor</li> <li>(6) P.T.O. brake supply connector</li> <li>(7) P.T.O brake solenoid</li> <li>(8) Reducer</li> <li>(12) Low-pressure switch</li> <li>(13) Solenoid valve (p.t.o. clutch)</li> <li>(14) Fitting (2WD version)</li> <li>(15) Differential lock solenoid</li> <li>(16) Differential lock supply connector</li> <li>(17) 4WD solenoid</li> <li>(18) Plug (2WD version)</li> <li>(19) Hare/tortoise solenoid</li> <li>(20) 17 bar supply connector</li> <li>(21) Plug (2WD version)</li> <li>(22) 4WD clutch supply connector</li> </ul> | <ul style="list-style-type: none"> <li>(23) Low-pressure output connector (to the maint filter and the Orbitrol steering valve)</li> <li>(24) Low pressure test coupler</li> <li>(25) Screw</li> <li>(26) Filter vacuum switch</li> <li>(27) Plugs</li> <li>(28) Cover plate (version without trailer brake)</li> <li>(29) Plug</li> <li>(30) O-ring</li> <li>(31) O-ring</li> <li>(32) O-ring</li> <li>(33) High-pressure output connector (to auxiliary spool valves)</li> <li>(34) Seal</li> <li>(35) O-ring</li> <li>(36) O-ring</li> <li>(37) Dowels</li> <li>(38) O-rings</li> <li>(39) Transfer pipe</li> <li>(40) Pin</li> <li>(41) Collar</li> <li>(42) Screw</li> <li>(43) Screw</li> <li>(44) Deflector</li> <li>(45) Suction pipe</li> <li>(46) Seal</li> <li>(47) Intake manifold</li> <li>(48) Pipe</li> <li>(49) O-rings</li> <li>(50) Oil filter</li> <li>(51) Nut</li> <li>(52) Washer</li> <li>(53) Pump gear</li> <li>(54) Key</li> <li>(55) Screw</li> <li>(56) Pump</li> <li>(57) Trailer brake valve</li> <li>(58) High pressure test coupler</li> </ul> |
|---|--|



6100 SERIES TRACTORS



Hydraulics - RH hydraulic cover

9101.3

View of internal layout

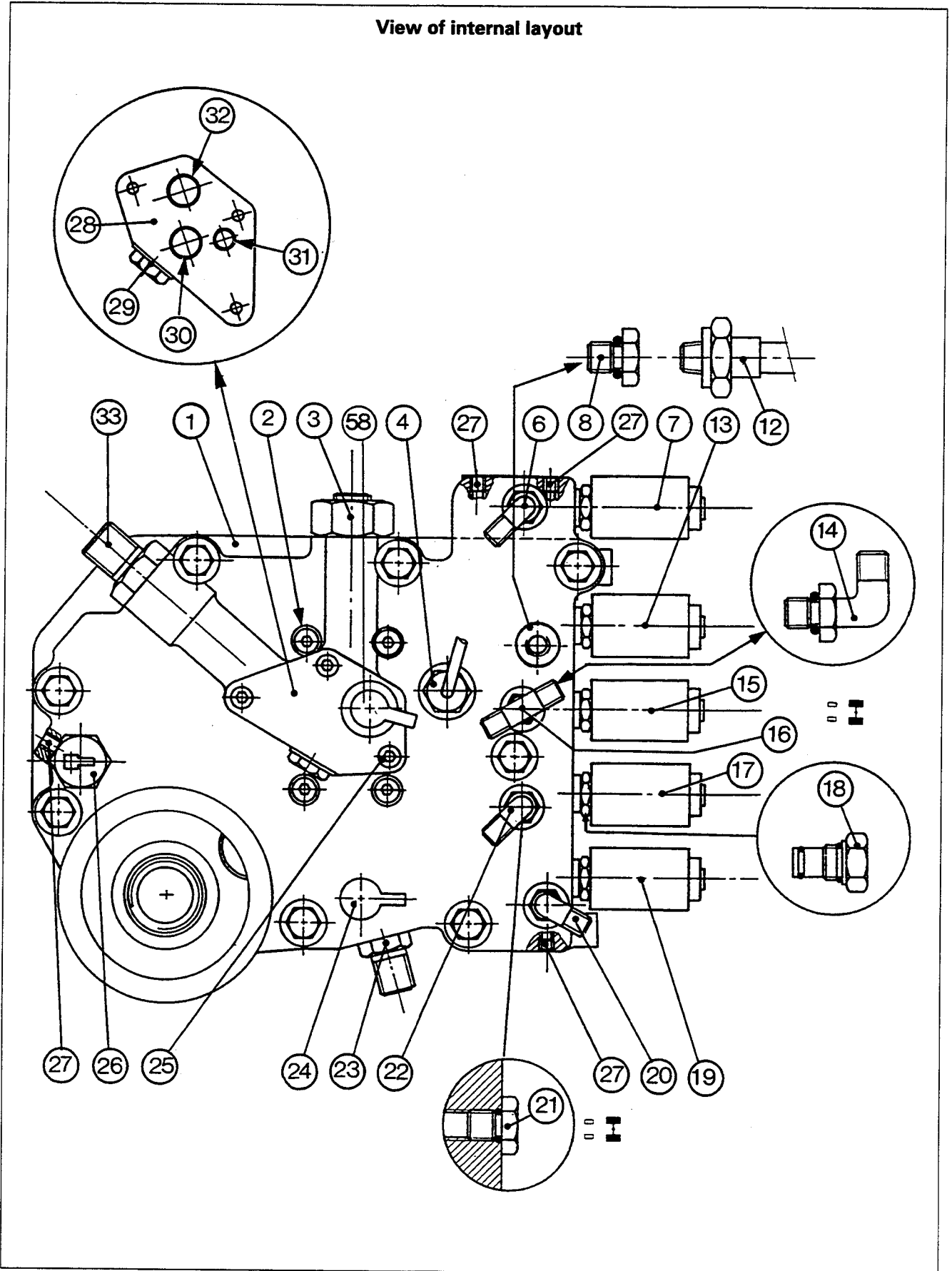





9101.4

6100 SERIES TRACTORS



**Hydraulics - RH hydraulic cover**

View of internal layout

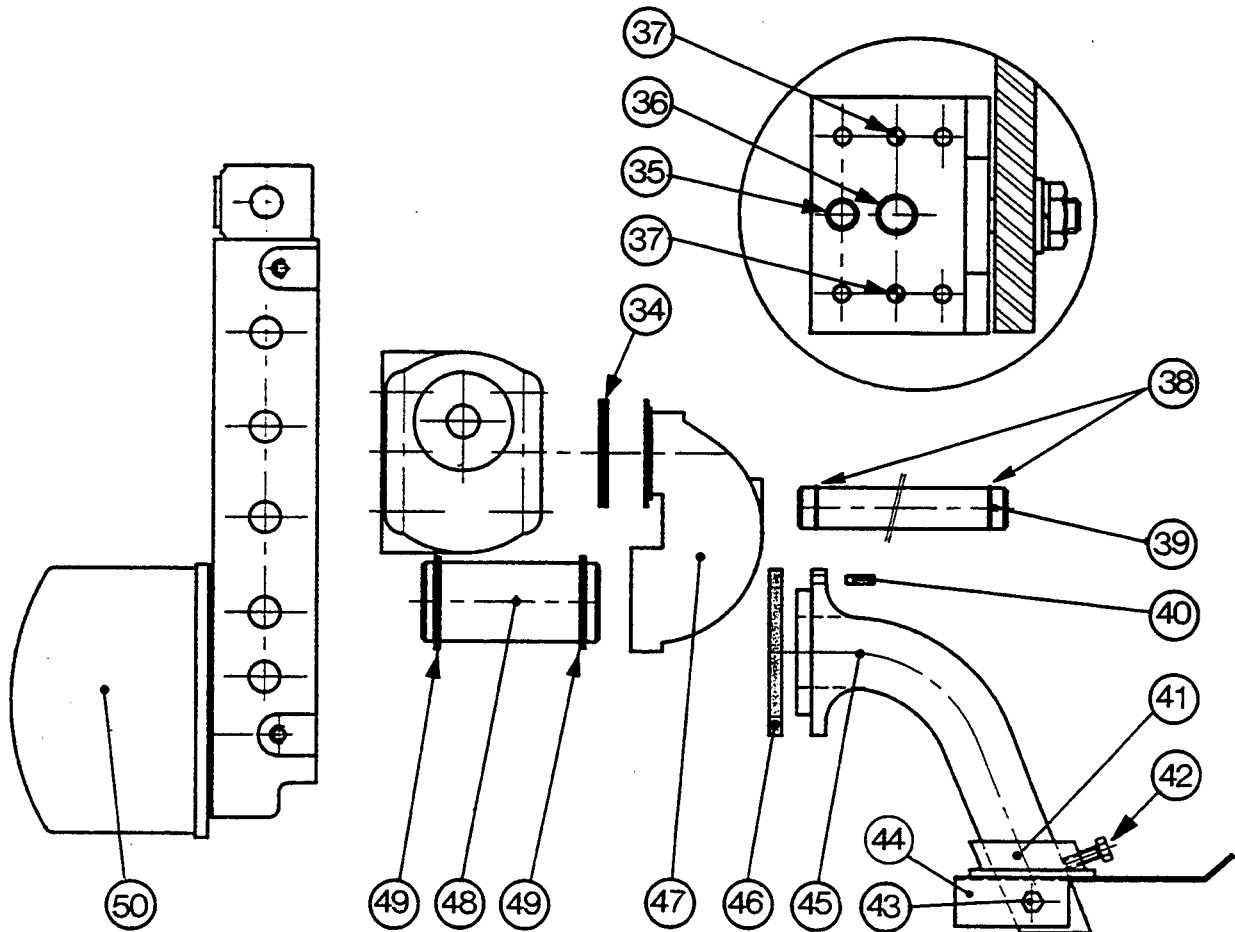
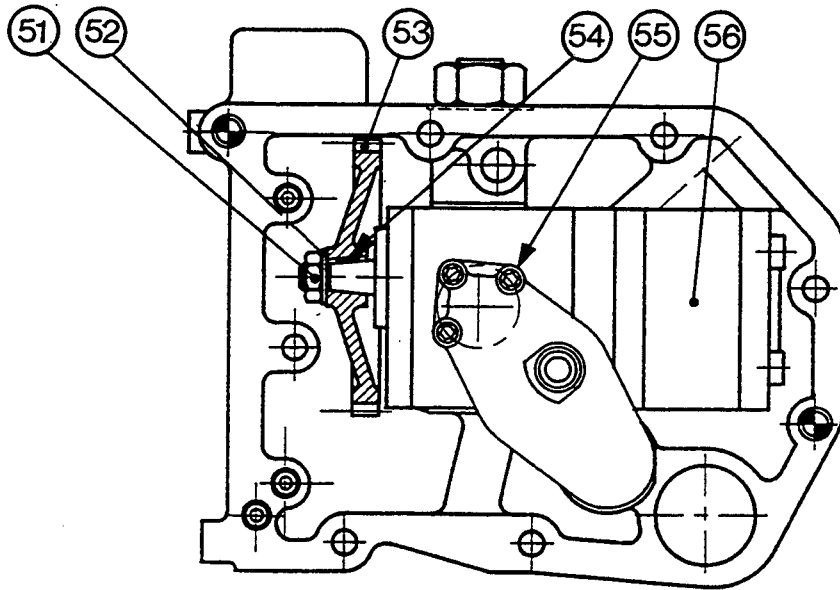



6100 SERIES TRACTORS



Hydraulics - RH hydraulic cover

9101.5

Exploded view

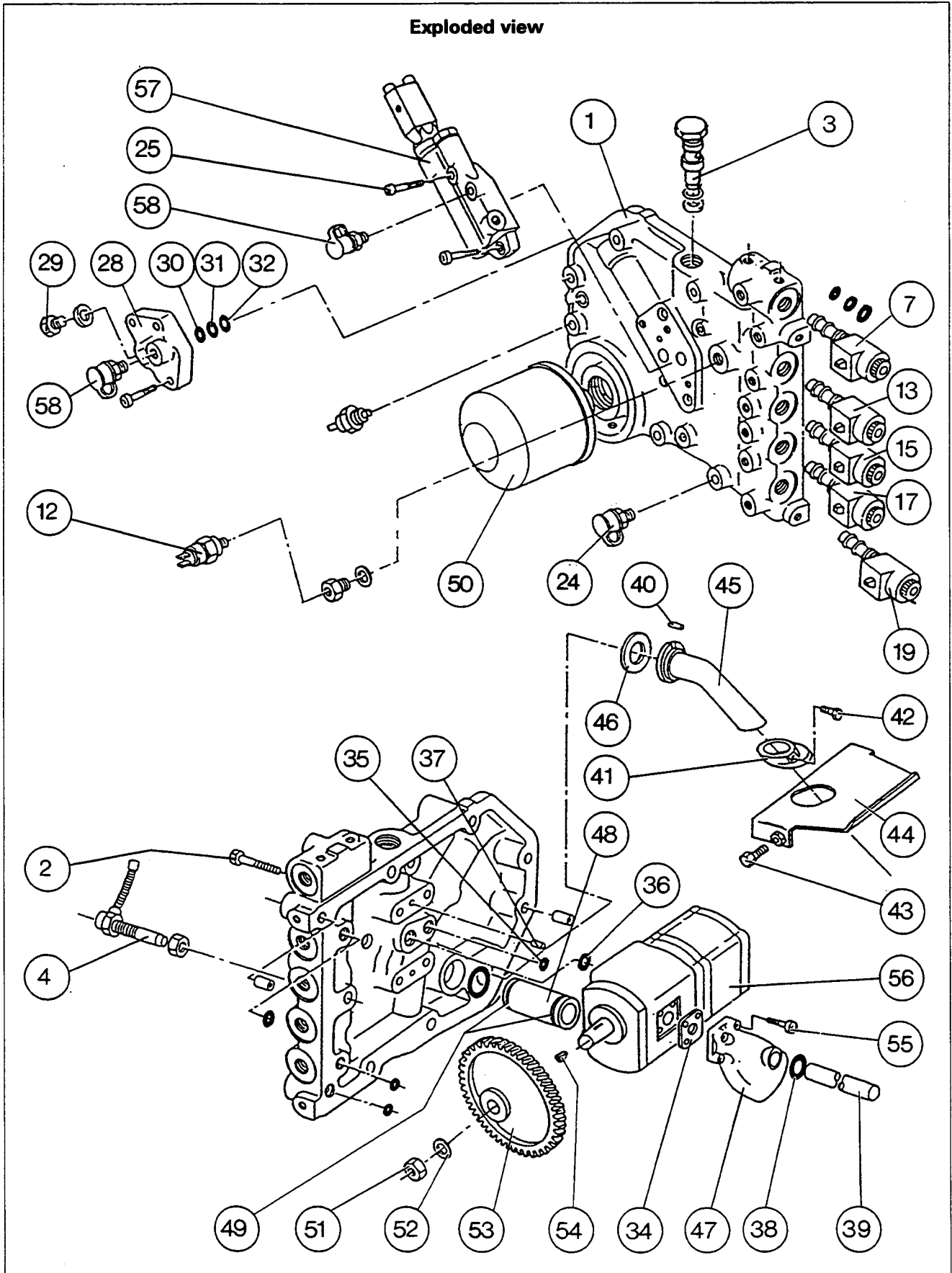



# 6100 SERIES TRACTORS



9101.6

## Hydraulics - RH hydraulic cover

### Identification of ports and lines

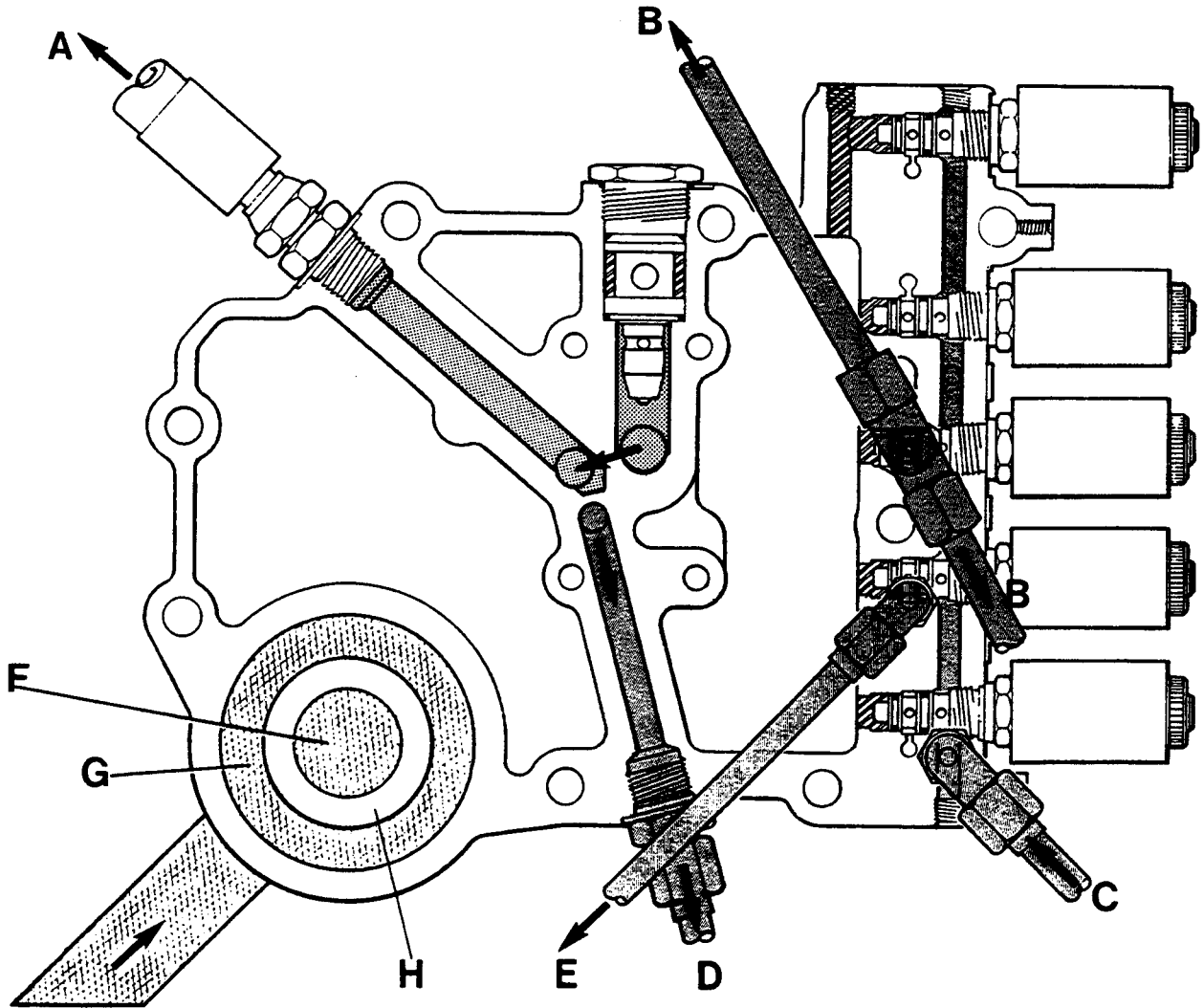

Low-pressure circuit

Return to housing

High-pressure circuit

Suction

- A** : Line to auxiliary spool valves
- B** : Front and rear differential lock (4WD)
- C** : 17 bar line coming from distribution valve
- D** : Low-pressure line to main filter (40 micron) and Orbitrol steering valve

- E** : Line to 4WD clutch (if fitted)
- F** : Suction
- G** : Suction (Output from strainer to two-stage pump)
- H** : Strainer



## Hydraulics - RH hydraulic cover

### A. Removal of cover

1. Carry out operations 1 to 7 (section 5 C01).

**For operations 2 to 12 refer to Fig. 1.**

Disconnect the clogging indicator harness. Remove the main filter (18) and its support.

2. Remove the strainer (1) to gain access to screw (2).
3. Remove the trailer brake socket feed pipe (3) (if fitted).
4. Remove the screws (5).
5. Remove the valve (6).

**Note: Do not disconnect the hose (7) on the pilot head, to avoid having to bleed the trailer brake circuit.**

6. Disconnect and block:

- the hose (8) towards the auxiliary circuit
- the pipe (10) and hose (12) of the differential lock control (4WD)

**Note: Hose (12) must be disconnected from the connector at the protector end.**

**On 2WD tractors, disconnect hose (10).**

- the supply pipe (16) of the 4WD clutch at both ends
- the supply pipe (11) of the p.t.o. brake at both ends
- the supply pipe (17) of the Orbitrol steering valve
- the pipe (15) coming from the distribution valve.

7. Disconnect the harness (9) of the engine speed sensor.

8. Disconnect the harness of the low-pressure switch (13).

9. Disconnect wire (4) from clogging indicator.

10. Disconnect the solenoids (mark the connections).

11. Remove the p.t.o. brake solenoid in order to avoid interference with the cab (low cab).

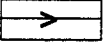
**Note: The p.t.o. solenoid is equipped with a diode. It is marked with the symbol** 

12. Remove the screws (2).

13. Remove the cover.

14. Remove the transfer pipe (1) (Fig. 2)

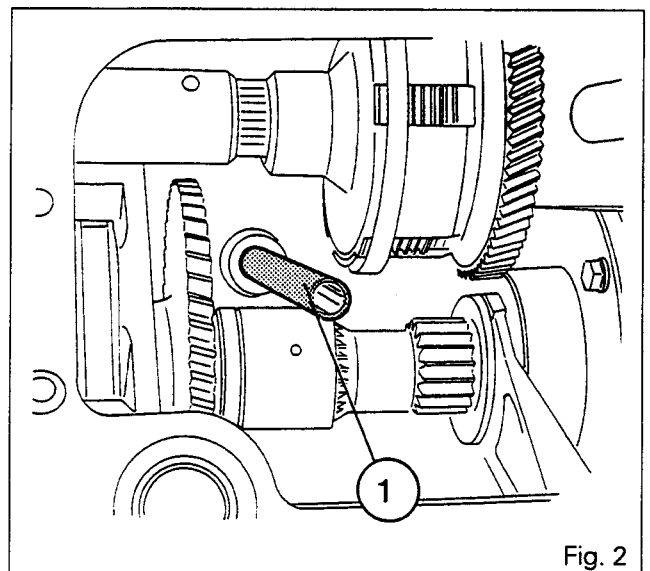

Fig. 2

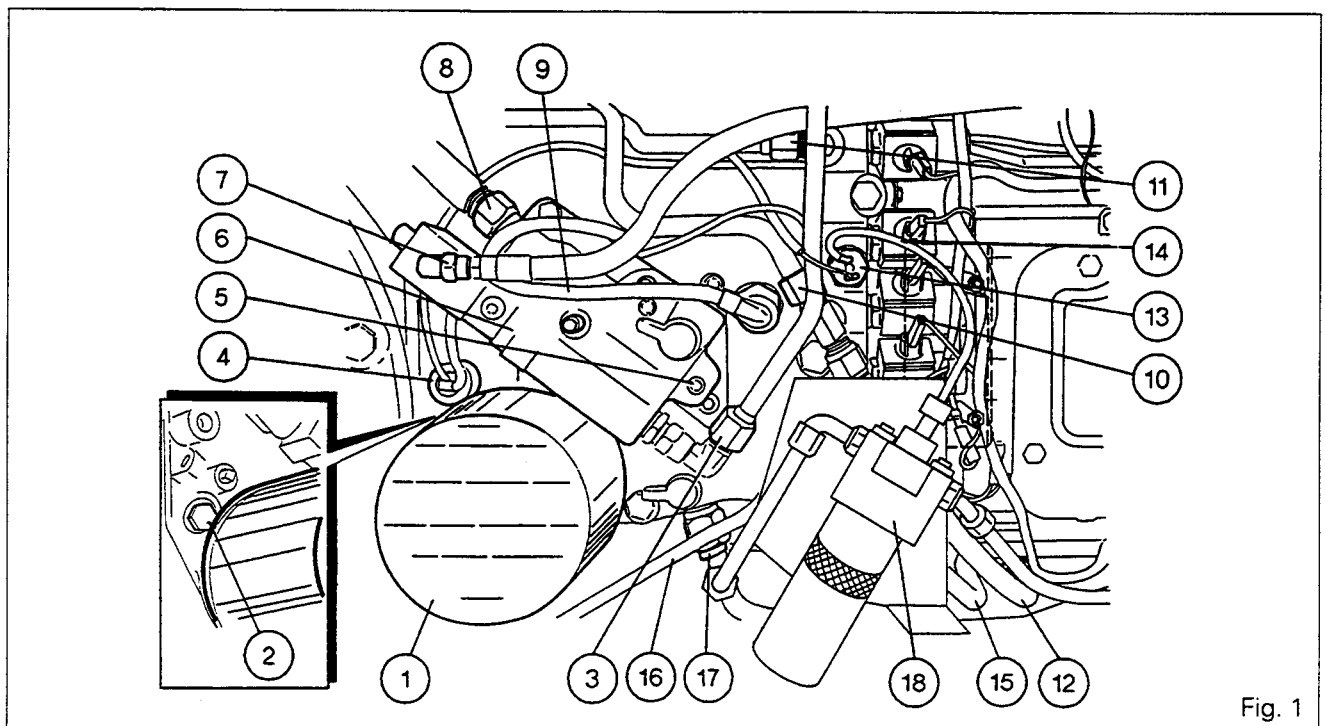

Fig. 1



9101.8

## 6100 SERIES TRACTORS

**Hydraulics - RH hydraulic cover****B . Refitting of cover**

15. Clean the housing and cover joint faces .
16. Check the presence of the two dowels **(1)** on the cover (Fig. 3).
17. **Fit new seals on the cover:**
  - for the Hare/Tortoise lines **(2)** (Fig. 3)
  - for the p.t.o. clutch line **(3)** (Fig. 3)
  - for the suction pipe **(4)** (Fig. 4) (ensure the pipe is the right way round; the pin on the housing must be in the notch (Fig. 4)).
18. Screw two guide studs, manufactured locally, in diametrically opposite positions on the housing.
19. Refit the transfer pipe.
20. Smear the cover joint face, with a sealing compound (Loctite 510 or equivalent).  
**Note: Take care not to obstruct the Hare/Tortoise lines.**
21. Refit the cover and screws **(2)** (Fig. 1).  
**Note: Remove the two guide studs. Tighten to a torque of 72-96 Nm.**
22. Refit the PTO brake solenoid and tighten to a torque of 18-20 Nm. Reverse operations 7 to 10.
23. Fix the harnesses with a clip.
24. Reverse operation 6.
25. Refit valve **(6)** (if fitted) (Fig. 1).  
**Note: Replace the O-rings.**
26. Refit the screws **(5)** (Fig. 1) and tighten them to a torque of 25-35 Nm.
27. Reverse operations 2 and 3.
28. Jack up the tractor. Refit the wheel.
29. Remove the jack and tighten the wheel nuts to a torque of 400-450 Nm.
30. Take away the chocks.
31. Top up the oil. Start the engine.
32. Check the operation of the electrical circuits, low-pressure switch, solenoids, filter vacuum switch and clogging indicator.
33. If the pump has had to be removed or replaced (see sections E and F) repeat hydraulic tests.  
Check the cover joint face and hydraulic connectors for leaks.

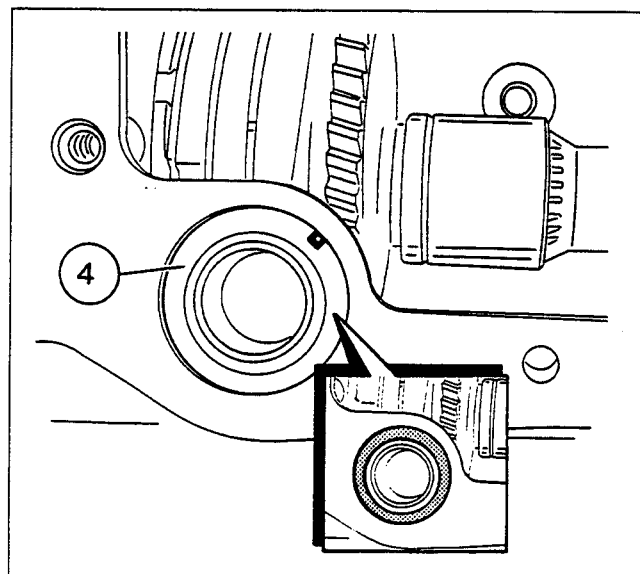
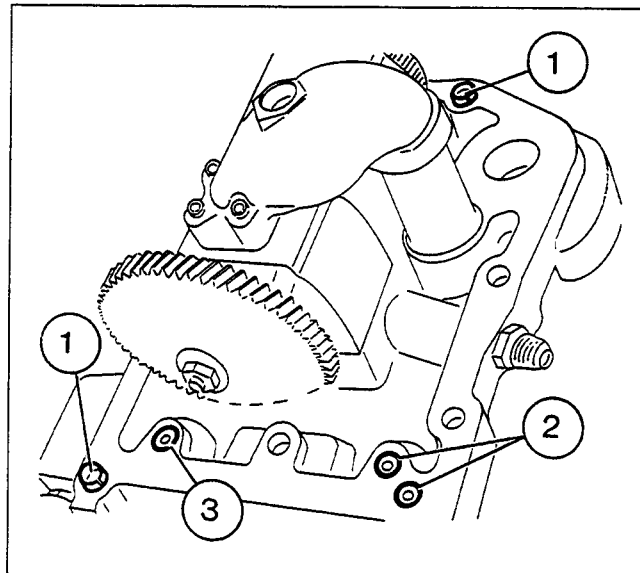



## Hydraulics - RH hydraulic cover

9101.9

### C . Disassembly and reassembly of high-pressure valve

#### Operation (Fig. 5)

If the pressure **P** exceeds 200 bar, spring **(4)** is compressed and valve **(7)** moves allowing oil to pass to the housing via port **C**.

#### Disassembly

34. Unscrew the plug **(1)**. Retrieve the shims **[2]**, withdraw the spring **(4)**.
35. Remove the O-ring **(5)**, withdraw the body **(6)** complete with valve **(7)** and washer **(8)** from the RH cover.

**Note : Ball (9) is fitted in the valve body.**

#### Reassembly

36. Check that the valve **(7)** slides freely in the valve body **(6)**.
37. Fit washer **(8)**, mount the body **(6)** complete with valve **(7)** in the cover. Position the O-ring **(5)**.
38. Fit the spring **(4)** and shims **[2]** and tighten the plug **(1)** to a torque of 50 - 60 Nm.

### D . Disassembly of cover

39. Remove the cover. Carry out operations 1 to 14.
40. Place the cover **(1)** in a vice with soft plastic jaws.
41. Remove the solenoids and plug **(18)** (2WD version).
42. Remove the low-pressure switch **(12)**.
43. Remove the reducer **(8)**.
44. Remove connector **(16)**, then fitting **(22)**, (or fitting **(14)** and a plug **(21)** on 2WD version).

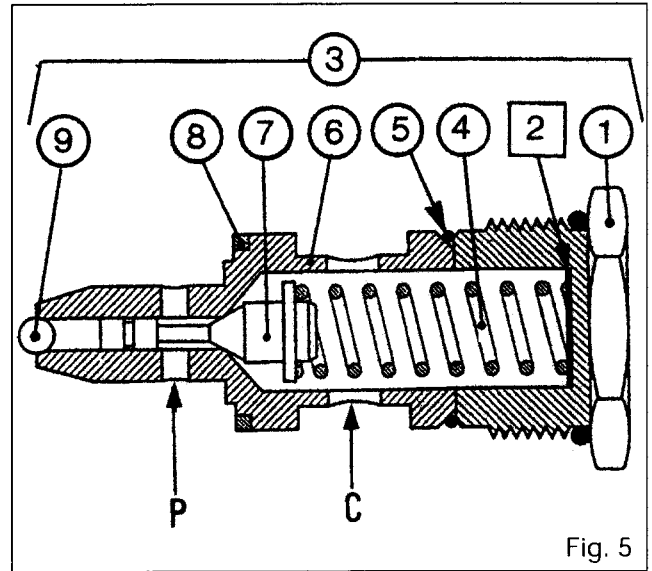

Fig. 5

45. Remove connectors **(6)**, **(20)**, **(23)**, **(33)**.
46. Remove the screws **(25)** and the cover plate **(28)** (version without trailer brake). Remove the O-rings **(30)**, **(31)** and **(32)**.
47. Unscrew the engine speed sensor **(4)**.
48. Remove the filter vacuum switch **(26)** and the test coupler **(24)**.
49. Remove the screws **(55)**, the intake manifold **(47)**, the seal **(34)** and the pipe **(48)**. Remove the seals **(49)**.
50. If necessary, unscrew the plugs **(27)**.

#### Removal of driving gear

51. Unscrew the nut **(51)**. Remove the washer **(52)**, the gear **(53)** and the key **(54)**.



9101.10

6100 SERIES TRACTORS



Hydraulics - RH hydraulic cover

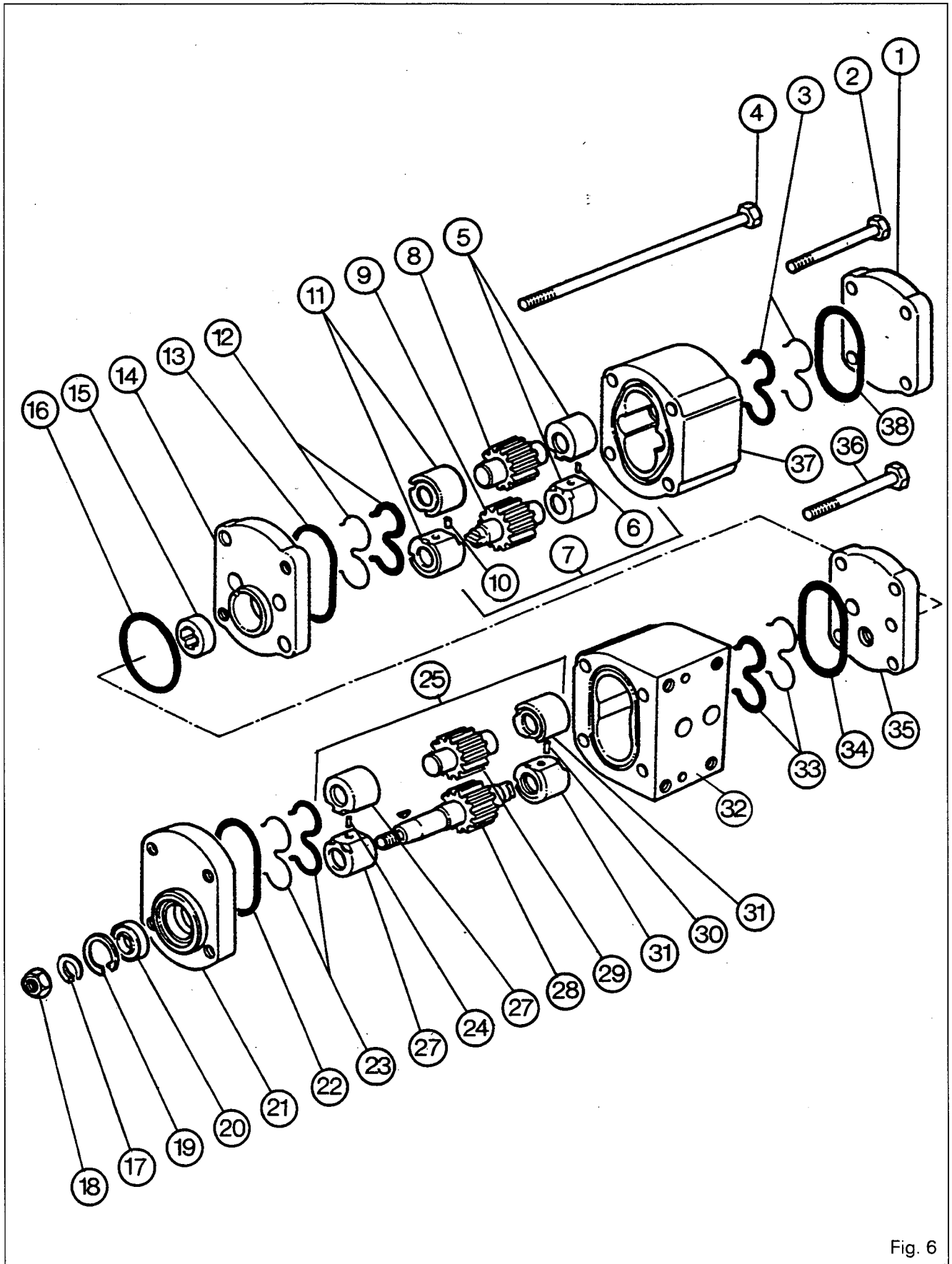

Fig. 6



## Hydraulics - RH hydraulic cover

### E . Removal and disassembly of pump

#### Removal (Fig. 7)

52. Remove the screws (2), and pump (56). Remove the O-rings (35) and (36).

**Note :** *The dowels (37) are force-fitted in the cover.*

#### Disassembly (Fig. 6)

53. Place the pump in a vice (Fig. 8).

54. Mark the position of: the stages, the intermediate plate and the plates.

55. Remove the screws (2) and (4).

56. Remove the cover plate (1).

57. Remove the composite seal (3) and seal (38). Separate the low-pressure stage (37) from the intermediate plate (14).

58. Remove the stage and the bearing/pinions assembly (7).

59. Remove the pinions (8) and (9) from the bearing assemblies (5) and (11).

**Note :** *Keep the bearing assemblies paired. Each bearing is linked by a dowel «P» (Fig. 9).*

60. Remove the composite seal (12) and seal (13).

61. Remove the intermediate plate (14), the driver (15) and the seal (16).

62. Untighten and remove the screws (36).

63. Remove the intermediate plate (35).

64. Remove the composite seal (33) and seal (34).

65. Separate the high-pressure stage (32) from the flange (21).

66. Remove the bearing/pinions assembly (25).

67. Remove the pinions (28) and (29) from the bearing assemblies (27) and (31).

**Note :** *Keep the bearing assemblies paired.*

68. Remove the composite seal (23).

69. Remove the seal (22).

70. Remove the circlip (19) and drive out the bush (20).

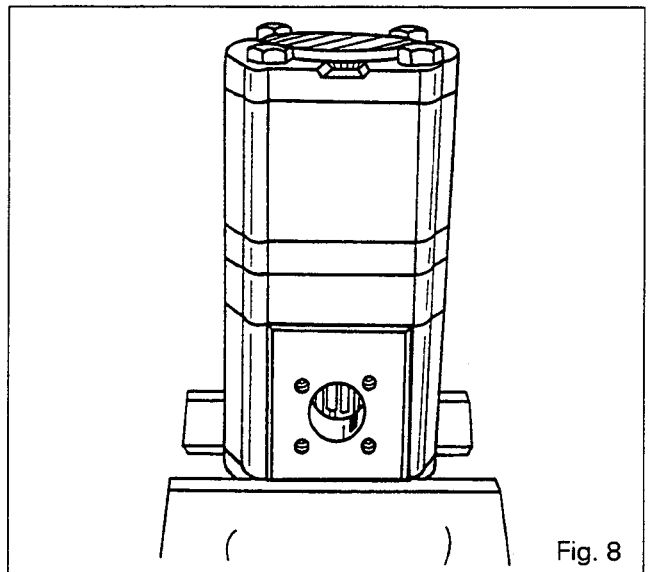
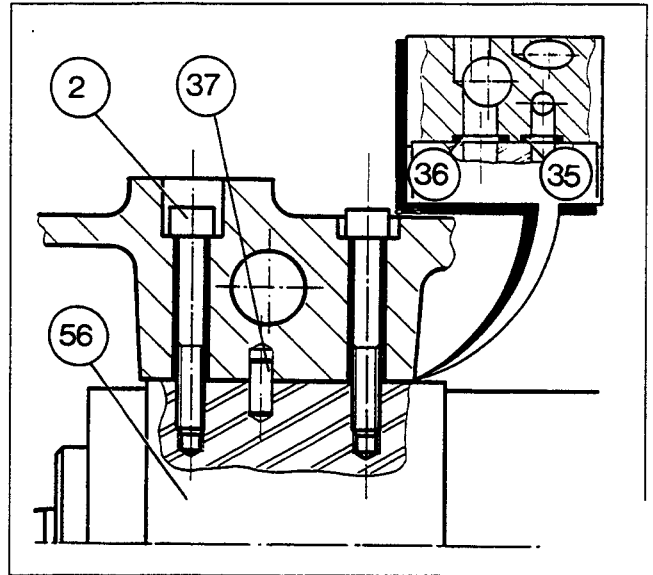

Fig. 8

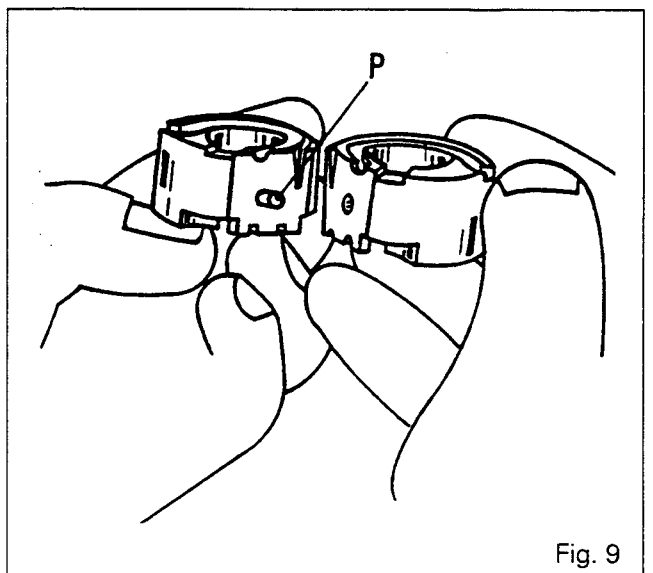

Fig. 9



**F. Reassembly and refitting of pump****Reassembly (Fig. 6)**

71. Clean and check the parts. Replace any which are defective.

**Note : The seals and the bush must always be replaced and fitted in the lubricated state.**

72. Push the seal ring (20) in the plate (21) and fit the circlip (19).

**Note : The bearing assemblies have different forms. The intermediate bearing assemblies (11) and (31) have a recess «E» (Fig. 10) for oil to pass to the low-pressure stage (37).**

73. Fit the bearing assembly (27) (without recess), located by the pin (24), in the high-pressure stage (32). Position the lubrication channels «G» towards the intake orifice «O», and the groove «R» of the composite seal (23) towards the plate (21) (Fig. 11).

74. Place the pinions (28) and (29) of the high-pressure stage in the bearing assembly (27).

**Note : The pinions of the high-pressure stage are wider.**

75. Position the composite seal (23) and seal (22) (Fig. 12).

76. Assemble the high-pressure stage (32) on the flange (21) according to the marks made at the time of disassembly.

77. Fit the bearing assembly (31) (with recess), located by the pin (30), in the high-pressure stage (32). Position the lubrication channels «G» and the recess «E» towards the intake orifice «O», and the groove «R» of the composite seal (33) towards the top (Fig. 13).

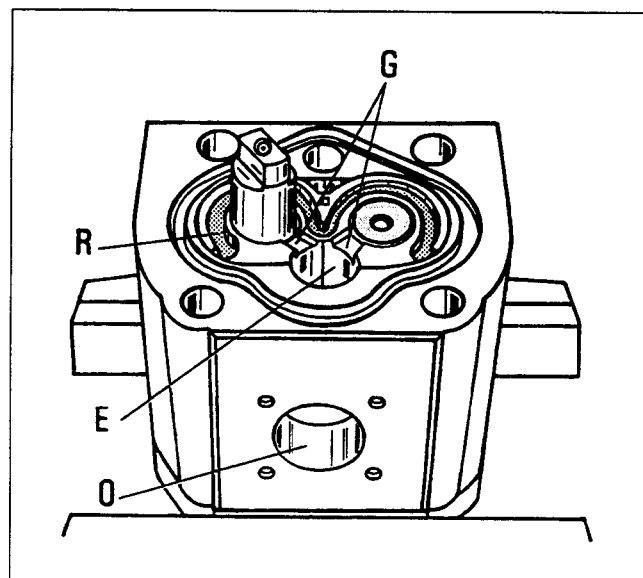
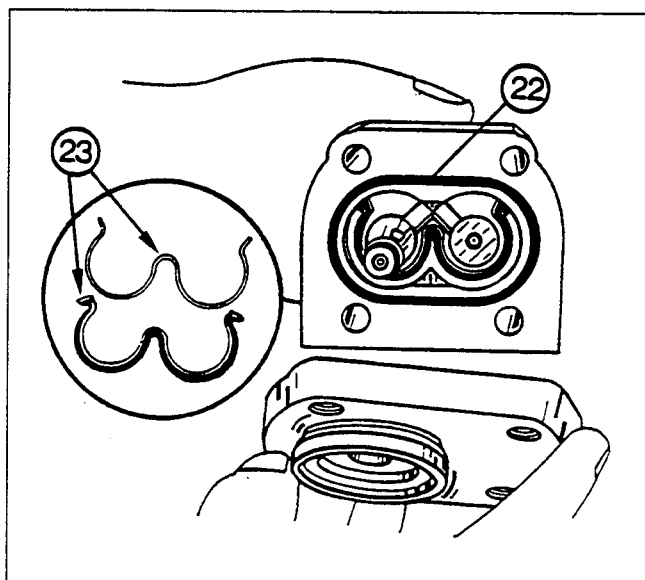
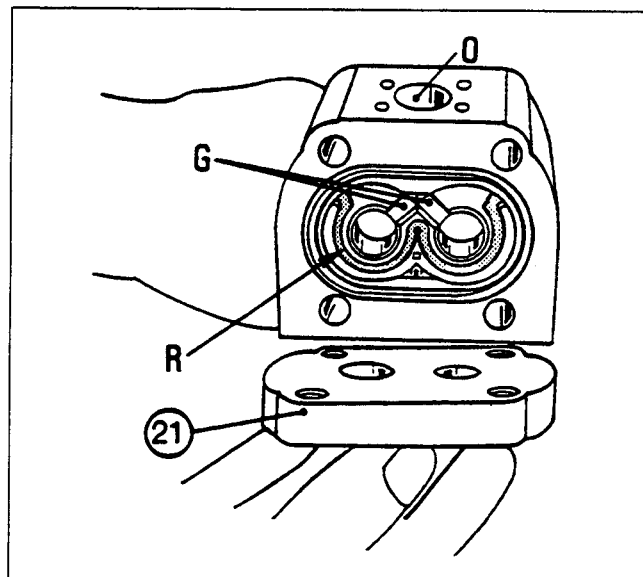
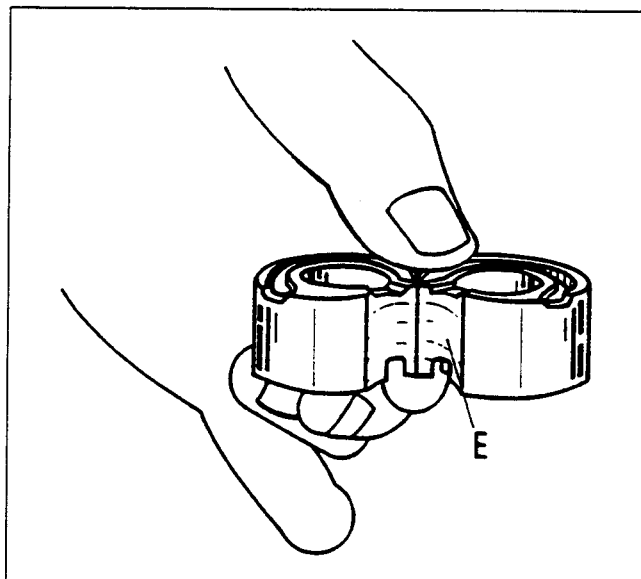



## Hydraulics - RH hydraulic cover

78. Position the composite seal (33) and seal (34).  
Assemble the flange (35) on the high-pressure stage (32) (Fig. 14) according to the marks made at the time of disassembly.
79. Centre the flange (35). Fit and tighten the screws (36) to a torque of 40-47 Nm.
80. Refit the driver (15) against the flat surface of the driving pinion (28). Position the seal (16).
81. Fit the intermediate plate (14) according to the marks made at the time of disassembly.
82. Fit the bearing assembly (11) (with recess), located by the pin (10), in the low-pressure stage (37). Position the lubrication channels «G» and the recess «E» towards the intake orifice «O», and the groove «R» of the composite seal (12) towards the intermediate plate (14) (Fig. 15).
83. Position the composite seal (12) and seal (13) (Fig. 15).
84. Assemble the low-pressure stage (37) on the intermediate plate (14) according to the marks made at the time of disassembly.
85. Place the pinions (8) and (9) in the low-pressure stage, ensuring that the flat surface of the driving pinion (9) enters the driver (15).
86. Fit the bearing assembly (5) (without recess), located by the pin (6), in the low-pressure stage (37). Position the lubrication channels «G» towards the intake orifice «O», and the groove «R» of the composite seal (3) towards the cover plate (1) (Fig. 16).
87. Position the composite seal (3) and seal (38) (Fig. 17).

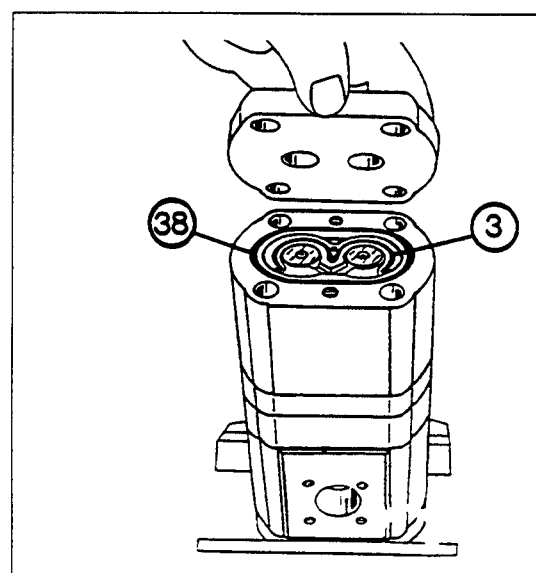
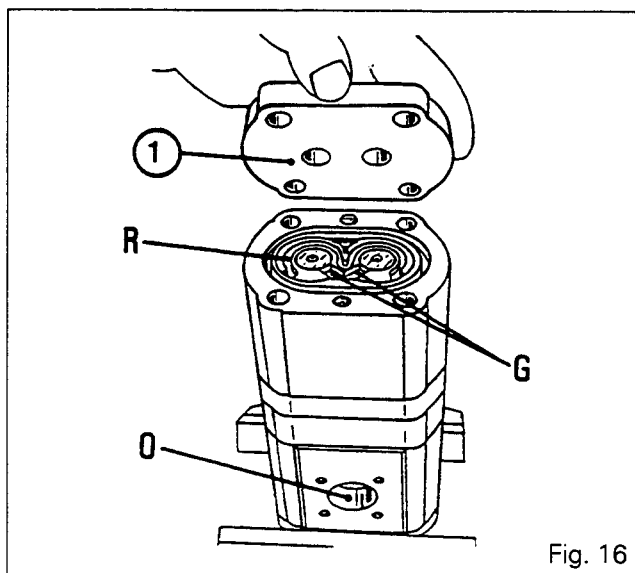
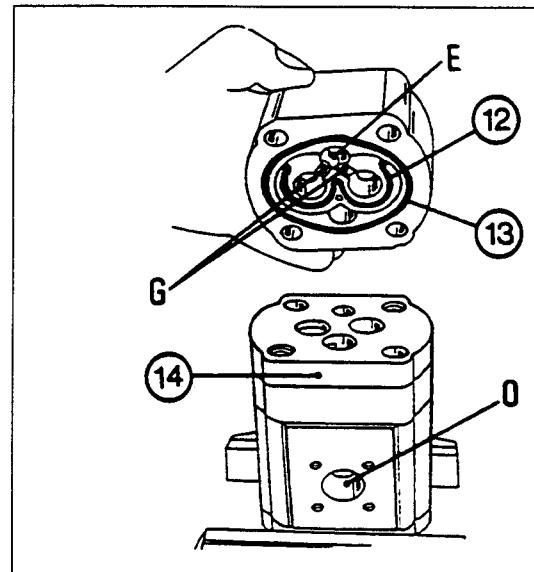
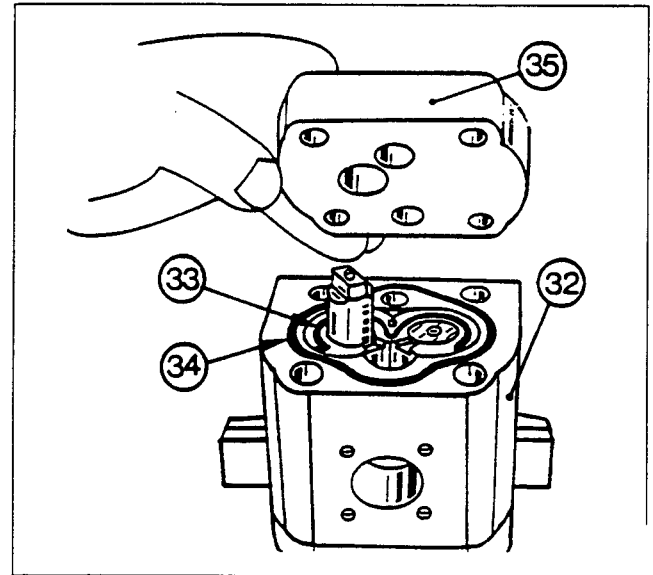



9101.14

## 6100 SERIES TRACTORS

**Hydraulics - RH hydraulic cover**

88. Centre the low-pressure stage (37) and assemble the cover plate (1) according to the marks made at the time of disassembly.
89. Fit and tighten the screws (2) and (4) to a torque of 40-47 Nm.
90. Manually check the rotation of the pump.

**Refitting**

91. Clean and check the parts. Replace any which are defective. Check that none of the channels of the cover are blocked.
92. Push the dowels (37) (if removed) into the cover (Fig. 18).
93. On the cover, fit new O-rings (35) and (36) in the counterbores of the high- and low-pressure channels (Fig. 18).
94. Inside the cover, apply a bead C of Loctite 575 around the four screw holes (Fig. 18).
95. Refit the pump on the dowels (37) (Fig. 7).
96. Smear the screws (2) with Loctite 221 and tighten them to a torque of 10 - 12 Nm (Fig. 7).

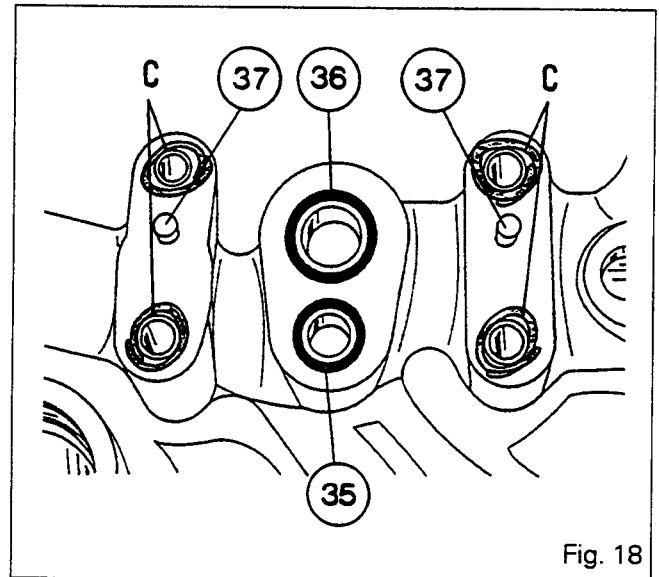

Fig. 18

**G . Reassembly of cover****Refitting of driving gear**

97. Position the key (54). Fit the driving gear (53), ensuring that it is correctly engaged on the key. Fit the washer (52).
98. Smear the nut (51) with Loctite 241 and tighten to a torque of 50 - 60 Nm.
99. Refit the plugs (27) smeared with Loctite 542 (if removed).
100. Replace the O-rings (49) on the pipe (48).
101. Replace the seal (34), refit the pipe and intake manifold (47). Refit the screws (55).
102. Fit the filter vacuum switch (26).
103. Fit and tighten the test coupler (24) with its O-ring.
104. Fit the sensor (4) (Autotronic, Datatronic) with "Loctite 577 Sensor Sealing" or equivalent.
105. Screw in the sensor, without forcing it, until it is in contact with the pump gear.
106. Unscrew the sensor 3/4 of a turn to provide clearance of approx. 1 mm between the sensor (4) and the gear (53). Tighten the nut (1) to a torque of 18-20 Nm (Fig. 19).
107. Fit the O-rings (30) (31) (32) in their respective locations on the cover plate (28) (version without trailer brake).

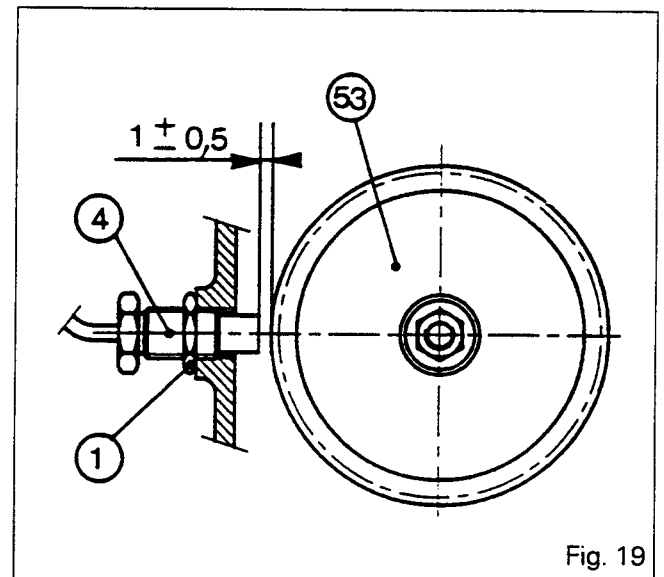

Fig. 19



---

## 6100 SERIES TRACTORS

---



9101.15

### **Hydraulics** - RH hydraulic cover

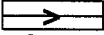
108. Refit the plate, fit the screws **(25)** and tighten them to a torque of 25 - 35 Nm.
109. Refit the connectors **(6)**, **(20)**, **(23)** and **(33)**.
110. Fit the plug **(21)** and connector **(14)** (2WD version), connectors **(16)** and **(22)** (4WD version).
111. Refit the reducer **(8)** with its O-ring and low-pressure switch **(12)**, lightly smeared with Loctite 221 (version with Autotronic, see table on page 2).
112. Refit the pressure switch **(12)** coated with Loctite 221.
113. Refit the solenoid and plug **(18)** (2WD version).  
**Note: To avoid interference with the cab, do not refit the p.t.o. brake solenoid on tractors with a low cab. The p.t.o. brake solenoid is equipped with a diode. It is marked with the symbol **  
**Tighten the solenoid to a torque of 18-20 Nm.**
114. Refit the high-pressure valve. Carry out operations 36 to 38.
115. Refit the cover. Carry out operations 15 to 33.





---

6100 SERIES TRACTORS

---



9102.1

**Hydraulics - LH cover**

*9 102 Left-hand hydraulic cover*

CONTENTS

<b>A. Removal</b> _____	<b>2</b>
<b>B. Refitting</b> _____	<b>2</b>



9102.2

## 6100 SERIES TRACTORS

**Hydraulics - LH cover****A . Removal**

1. Immobilise the tractor and lift the rear with a trolley jack. Remove the rear wheel and put a stand in place.
2. Drain the gearbox.
3. Mark and disconnect the cable of the lift (1) and lowering (2) solenoid valves (Fig. 1A).
4. Disconnect and block the lift valve supply hose (3) and the ram supply tube (4) (Fig. 1A).  
On tractors with brake lubrication, disconnect the union (10) and tube (11) (Fig. 1B).
- Note: On tractors with a low cab, remove the bolts (7) and take away the valve to facilitate access to the upper bolts (5) of the cover.**
5. Remove the handbrake control support (6). Disconnect the ground speed power take-off control (8) and remove the support (9) (if fitted) (Fig. 1A). Remove the bolts (7), remove the valve to facilitate access to the upper bolts (5) on the cover (low cab) (Fig. 1A).
6. Remove the cover and the transfer tube.

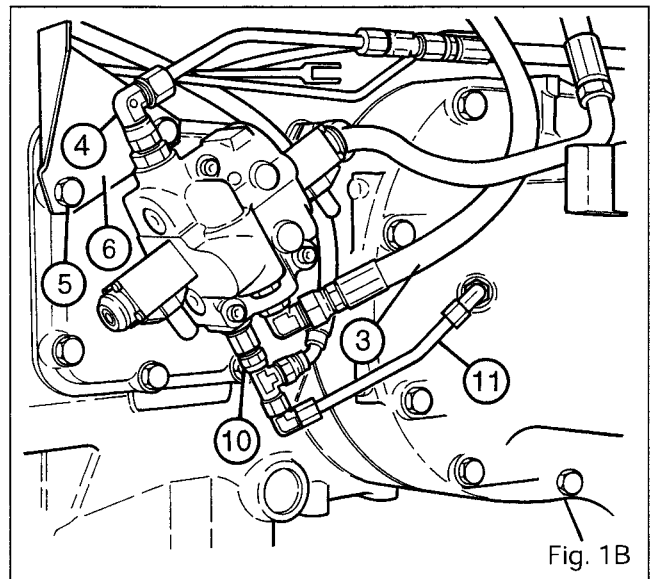
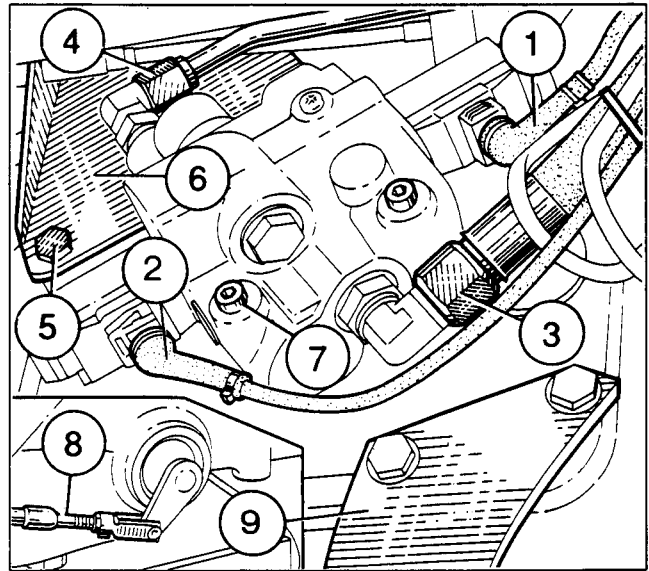

Fig. 1B

**B . Refitting**

7. Clean the cover and housing joint surfaces .  
**Note: As from serial number E240024, a check valve (1) (Fig 3) screwed onto the inner face of the cover maintains a pressure of approximately 5 bar for the lubrication of brakes (see section 9A01).**
8. Check that the O-rings (1) of the transfer tube are not damaged and refit the tube (Fig. 2).
9. Coat the housing joint surface with a sealant (Master Joint or equivalent).
10. Screw in two opposing guide studs G (Fig. 2).
11. Refit the cover.
12. Mount the handbrake control support (6), the GSPTO support (9) (if fitted) (Fig. 1A). Remove the guide studs. Fit and tighten the bolts to a torque of 72 - 96 Nm. Connect the controls.  
On tractors with a low cab, check that the O-rings of the lift control valve are not damaged and refit the valve.  
Fit and tighten the bolts (7) to a torque of 25 - 35 Nm (Fig. 1A).

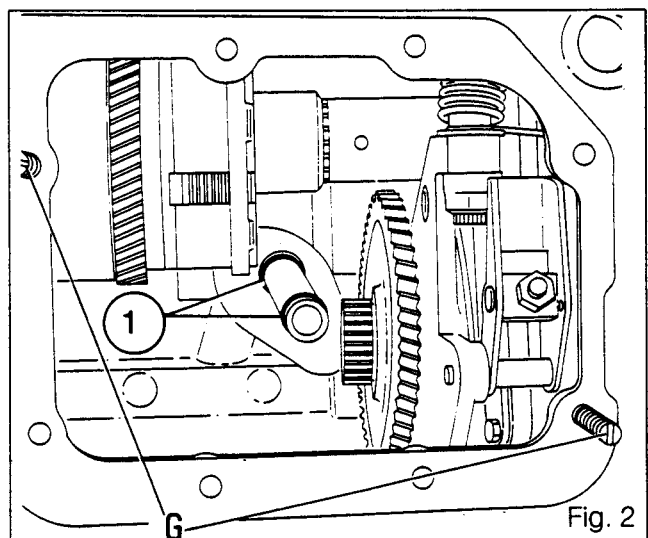

Fig. 2



## Hydraulics - LH cover

13. Check the adjustment of the control :
  - of the handbrake, see section 6 D01.
  - of the ground speed power take-off (if fitted) (see section 7D01).
14. Reconnect the supply hose **(3)** of the lift valve and the feed tube **(4)** of the lift rams (Fig. 1A).
15. Reconnect the lift **(1)** and lowering **(2)** solenoid valves (yellow connector) (Fig. 1).
16. Fasten the cable to the valve supply hose with a clip.
17. Refit the wheel. Take away the stand and the trolley jack. Tighten the nuts to a torque of 400 - 450 Nm.
18. Top up the housing oil level.
19. Start the engine.
20. Check the operation of the lift system and check for leaks at the joint faces of the cover and the hydraulic connectors.

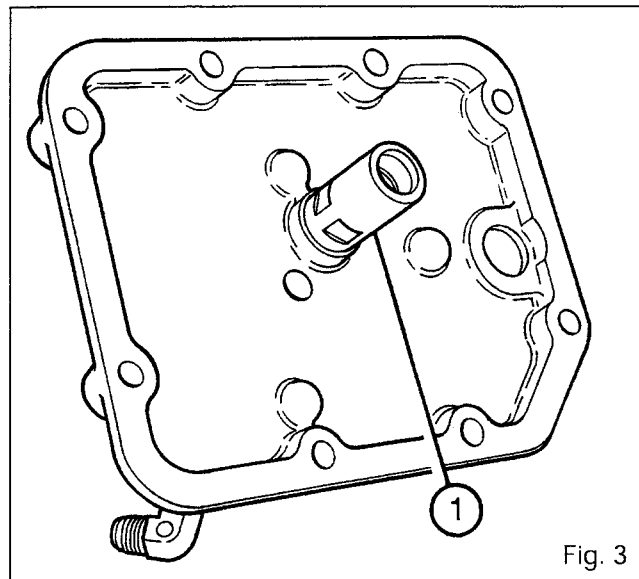

Fig. 3

### Version without lift

The cover (valve support) is replaced by a plate with a hydraulic sleeve.







9 J01 Clutch control valve

CONTENTS

-	<b>General</b> _____	2
A.	<b>Clutch valve operating phases</b> _____	3
B.	<b>Dismantling and reassembling the clutch valve</b> _____	7
C.	<b>Service tool</b> _____	9



# 6100 SERIES TRACTORS



9J01.2

## Hydraulics - Clutch control valve

### General

The distribution unit (3) (Fig. 1) installed on the front right-hand side of the gearbox consists of two separate sections, one for clutch control and the other controlling the four Dynashift ratios.

- **Clutch section:** This consists of a series of spools, seals, a check valve and a piston, which are replaceable using kits the contents of which are described in the spare parts catalogue.

- **Dynashift section** (see section 9 K01).

### Purpose of the control valve

This valve installed on the 17-bar system performs the following functions:

- Supply to the clutch at 17 bars when the clutch pedal is released (in clutch engaged position).
- Modulation of clutch engagement pressure: 0 to 11 bars.
- Starting safety when the tractor is started up by external means. To activate the clutch, the clutch pedal must be pressed once.
- Low hydraulic pressure safety on starting the tractor. The clutch only works if the supply pressure is more than 12 bars. The clutch is automatically disengaged if the pressure falls below 3 bars.
- The ports «O» (Fig. 2) allow the return of leaks to the housing.

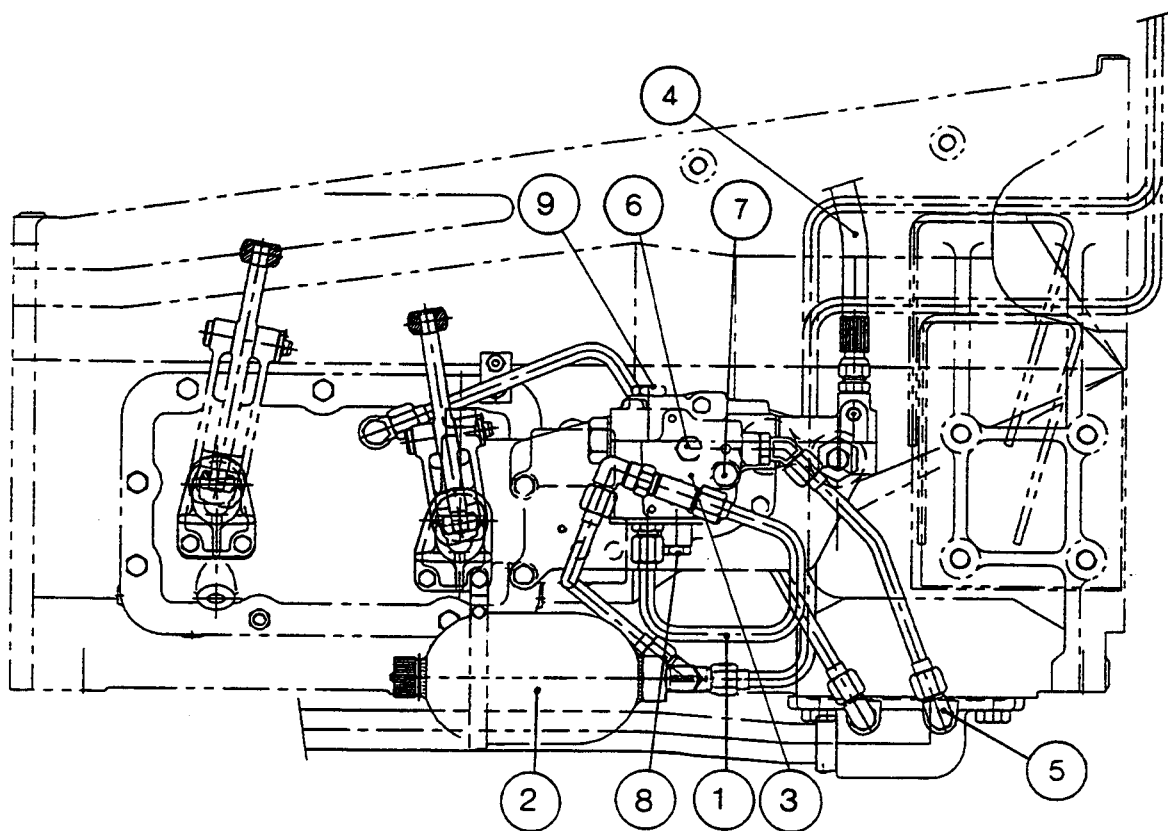

- |                         |   |
|-------------------------|---|
| 1. 17-bar supply        | 6. Clutch diagnostic connector          |
| 2. Accumulator          | 7. Dynashift front diagnostic connector |
| 3. Distribution unit    | 8. Dynashift rear diagnostic connector  |
| 4. Master cylinder hose | 9. Dynashift non-return valve           |
| 5. Clutch supply pipe   |   |

Fig. 1



## Hydraulics - Clutch control valve

9J01.3

### Description

The valve comprises two spools. The upper spool actuated by the clutch master cylinder controls supply to the clutch.

The lower spool actuated by the 17 bar pressure ensures the system's hydraulic safety function.

### Clutch disengagement before switching the safety valve (Fig. 3)

The main spool (5) is pushed rearwards and compresses the spring (2) under the action of the piston (19) actuated by the master cylinder. The pressure from the 17-bar system passes via the shoulder of the main spool (5) and starts to act on the front face of spool (4). The clutch is then connected to the return.

## A. Clutch valve operating phases

### Neutral position, engine running (Fig. 2)

If the tractor is started without pressing on the clutch pedal, the pressure rises to 17 bar but all the intake ports are closed and the clutch is not hydraulically supplied.

P = 17 bar  
R = Return  
E = Clutch

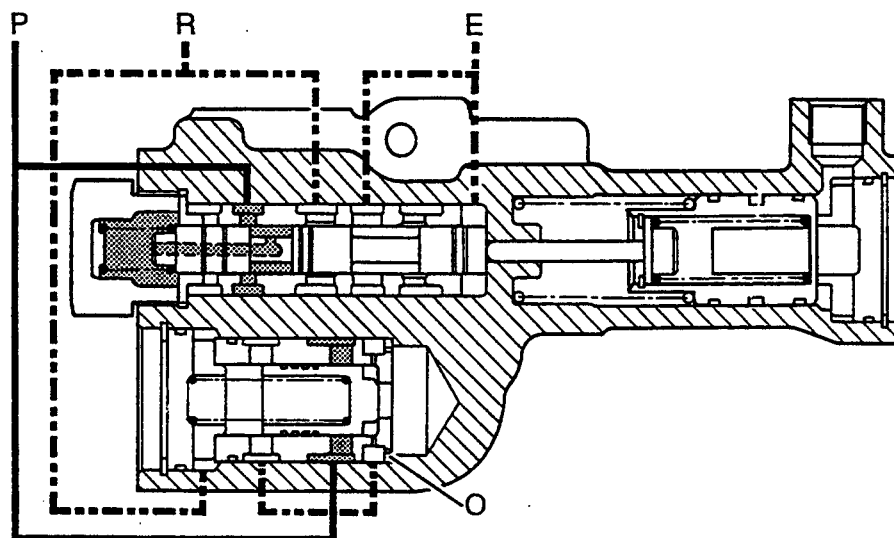

Fig. 2

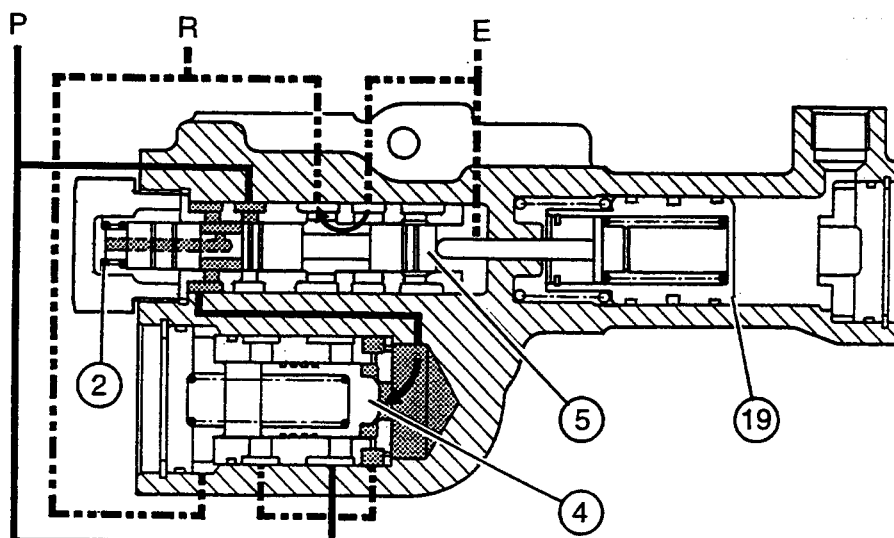

Fig. 3



6100 SERIES TRACTORS



9J01.4

**Hydraulics - Clutch control valve**

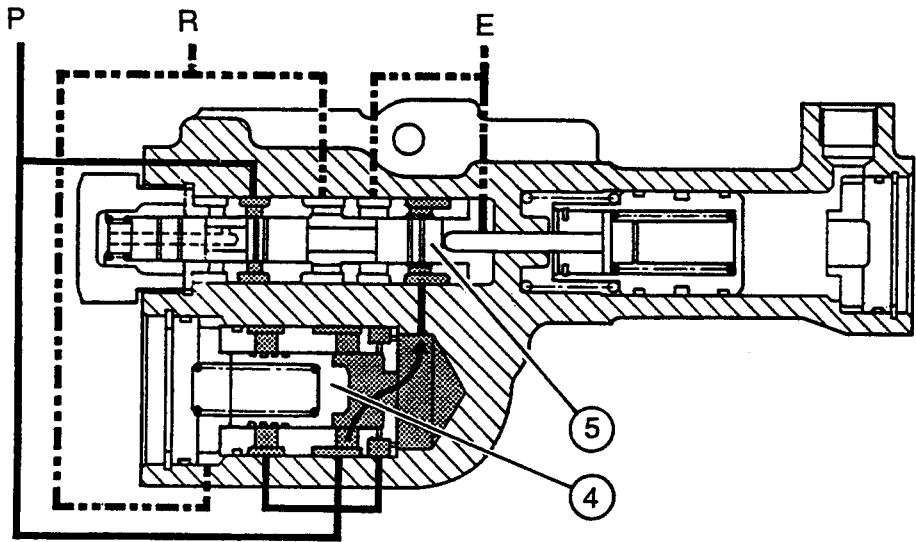

Fig. 4

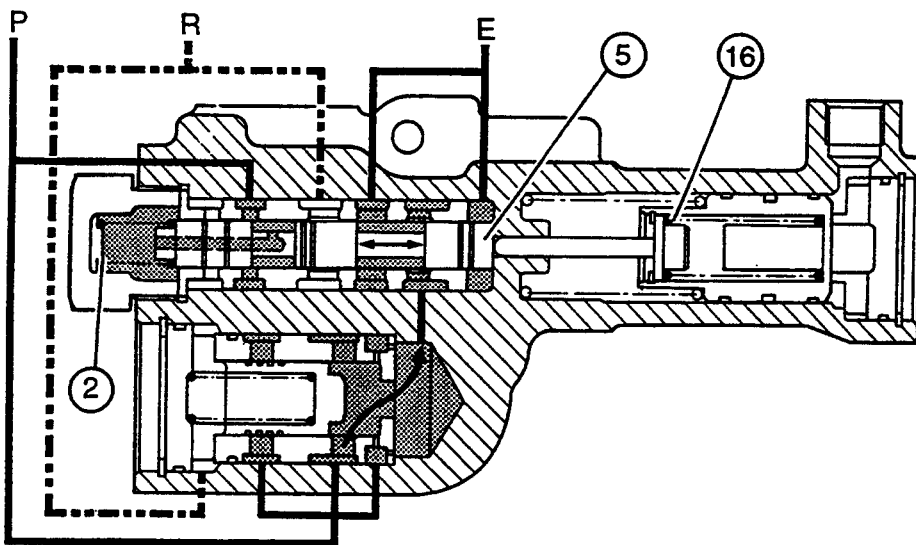

Fig. 5

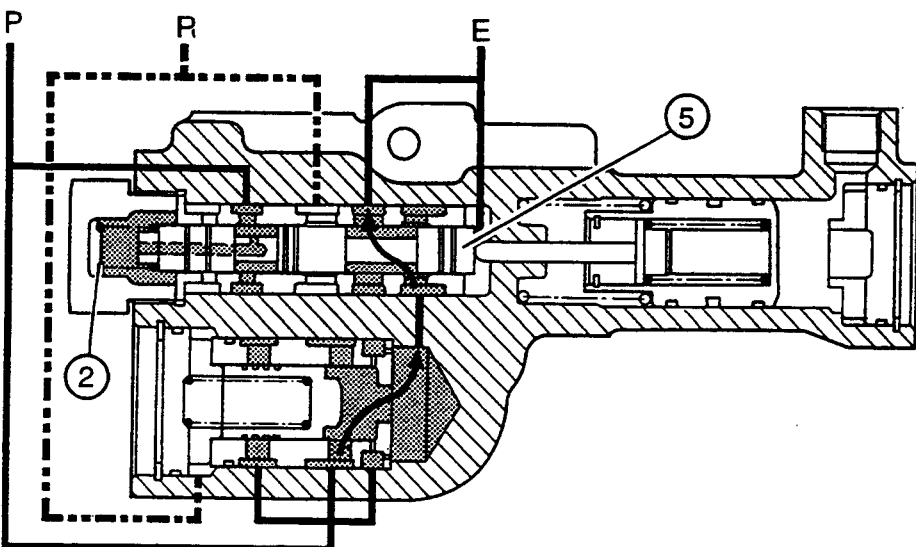

Fig. 6



## Hydraulics - Clutch control valve

### Clutch disengagement, switching of safety valve (Fig. 4)

Spool **(4)** moves rearwards when the pressure is greater than 12 bars. When fully open, spool **(4)** allows communication with the front of the main spool **(5)**.

### Clutch engagement, modulation phase (Fig. 5)

When the clutch pedal is released, the pressure supplying the clutch is modulated by the position of the main spool **(5)**.

This position is regulated:

- at the rear, by the 17-bar pressure and spring **(2)**,
- at the front, by the clutch engagement pressure and spring **(16)**.

When the pedal is slightly released, the tension of spring **(2)** decreases. The main spool **(5)** moves forward and allows communication between the 17-bar line and the clutch.

The pressure in the clutch increases, pushing the spool rearwards in its position of equilibrium.

From this intermediate position, while slightly pressing the pedal, the load on spring **(2)** increases. The spool moves rearwards, opening communication between the clutch and return.

The pressure in the clutch decreases and the spool moves forwards to its position of equilibrium.

Modulation is actuated when the pedal has been depressed by about 25 mm. The fully disengaged position is reached 25 mm before the pedal end of travel (Fig. 10).

### Clutch fully engaged position (Fig. 6)

When the pedal is completely released, spring **(2)** pushes spool **(5)** forwards causing the 17-bar system to open fully to the clutch.



6100 SERIES TRACTORS



9J01.6

Hydraulics - Clutch control valve

Overall view

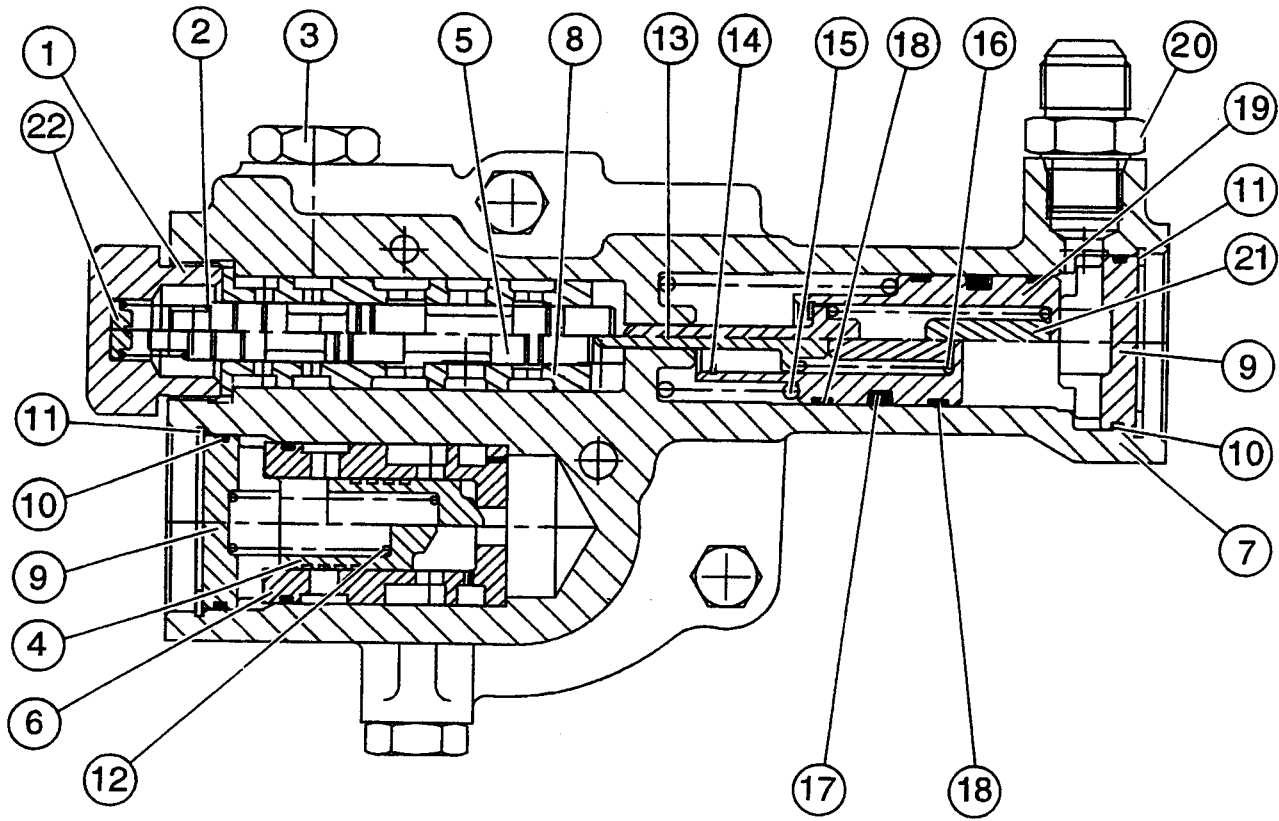

List of parts

- (1) Plug
- (2) Spring
- (3) Non-return valve
- (4) Safety valve spool
- (5) Main spool
- (6) Main spool sleeve
- (7) Valve body
- (8) Pressure valve sleeve
- (9) Plugs
- (10) O-ring
- (11) Circlip
- (12) Spring
- (13) Pusher
- (14) Circlip
- (15) Spring
- (16) Modulation spring
- (17) Quadring seal
- (18) Guide rings
- (19) Piston
- (20) Calibrated coupling
- (21) Modulation limit stop
- (22) Spool limit stop

Fig. 7



## Hydraulics - Clutch control valve

9J01.7

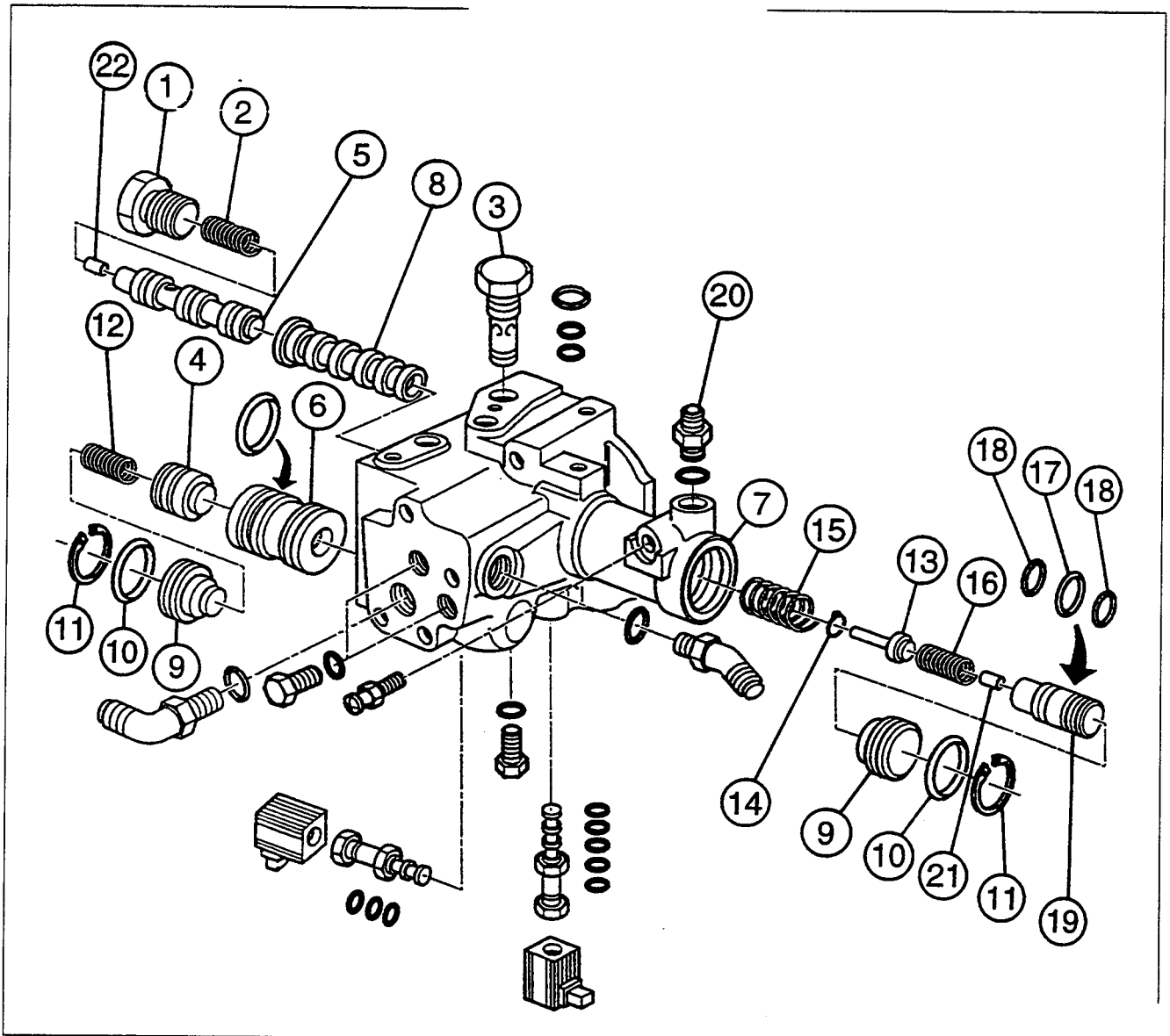

### B. Dismantling and reassembling the valve (Fig. 8)

#### Dismantling

To remove and refit the valve, see section 4 A01, § D.

1. Using the locally manufactured tool described in Part C, remove the circlip (11) and remove the plug (9) (Fig. 9) from assembly A. Remove the plug from assembly B in the same manner. Remove assemblies A and B, taking visual note of their positions.

2. Unscrew plug (1) and remove assembly C in the same way as in the previous operation.

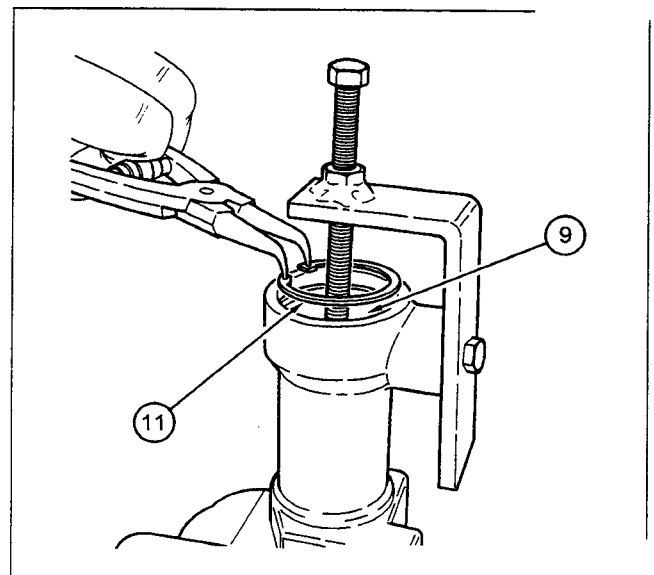





## 6100 SERIES TRACTORS



9J01.8

### Hydraulics - Clutch control valve

#### Reassembly

3. Check and clean the parts. Replace any parts that are scored or deformed. Check that the check valve (4) and spool (5) slide freely in sleeves (6) and (8). Before reassembling, lubricate the seals with transmission oil.
4. Replace the O-rings (10) and assemblies A, B and C with repair kits. Fit the circlips (11).

**Note:** Before fitting the piston in assembly A, preform the guide rings (18) in circular shapes, with the knurled side facing valve body (7). Lubricate the rings with miscible grease and position them in the grooves on the piston. The bore in coupling (20) is calibrated.

#### 5. Checking the modulation pressure

- Make sure that all the solenoid valves are not hydraulically supplied.
- The front axle assembly (if fitted) must be engaged (hydraulic pressure being used for clutch disengagement only). Place the range change lever in the Tortoise position and the Dynashift lever in position D.
- On the diagnostic connector (1), connect a pressure gauge (approx. 30 bars) equipped with a coupler 3582045M1 (Fig. 10).
- Press the pedal and check the modulation pressure from 0 to 11 bars through its travel. When the pedal is released, the clutch is under a pressure of 17 bars.

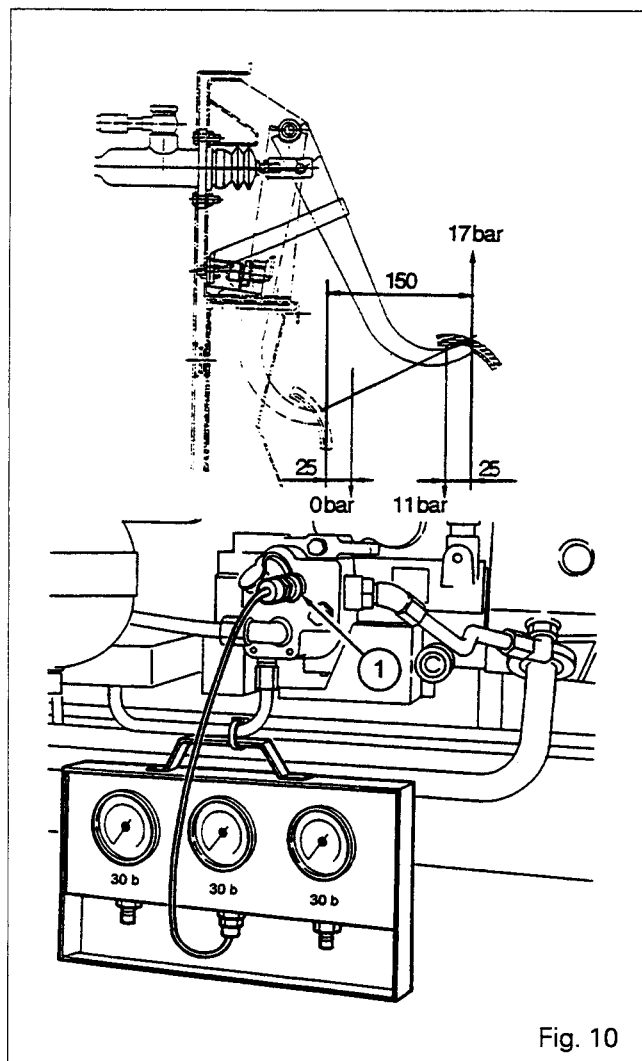

Fig. 10

#### Tightening torques (Fig. 11)

- Plug (1) smeared with Loctite 542: 50 Nm.
- Non-return valve (3): 28 to 30 Nm.

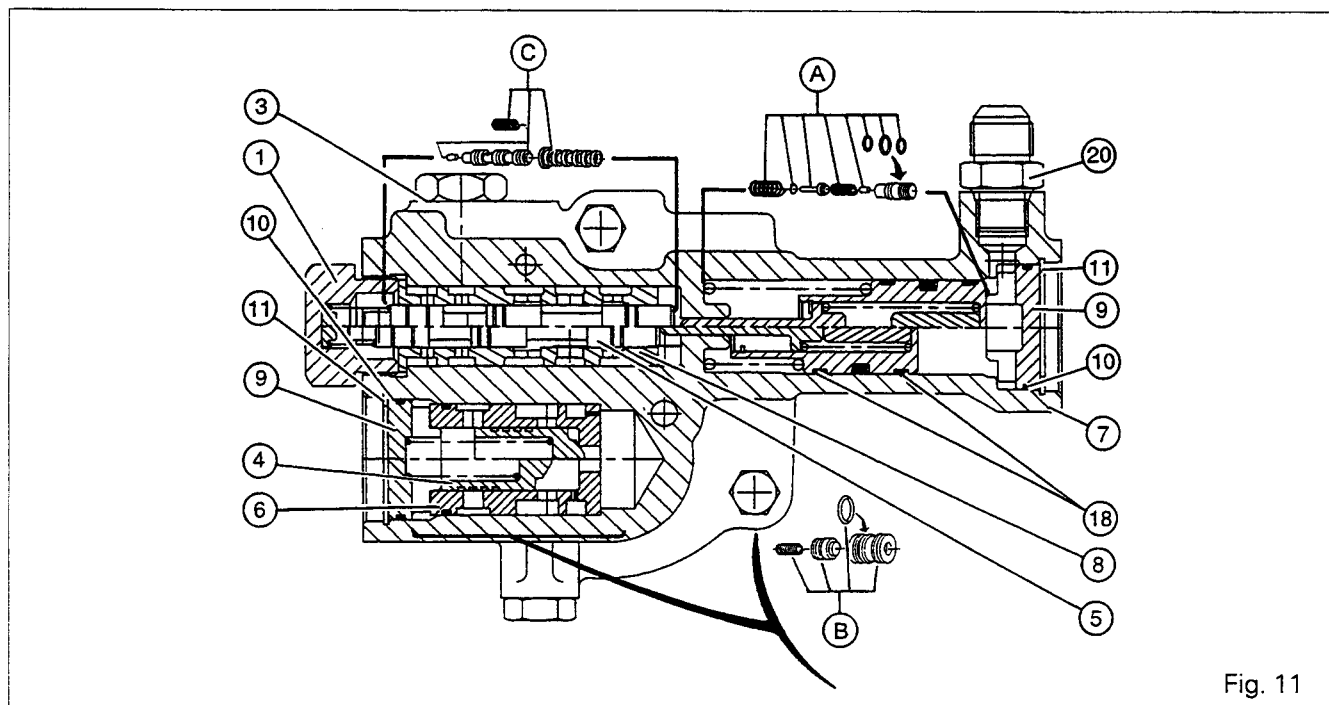

Fig. 11



6100 SERIES TRACTORS



9J01.9

**Hydraulics** - Clutch control valve

**E. Service tool**

Tool to be manufactured locally

- Spring compression tool.

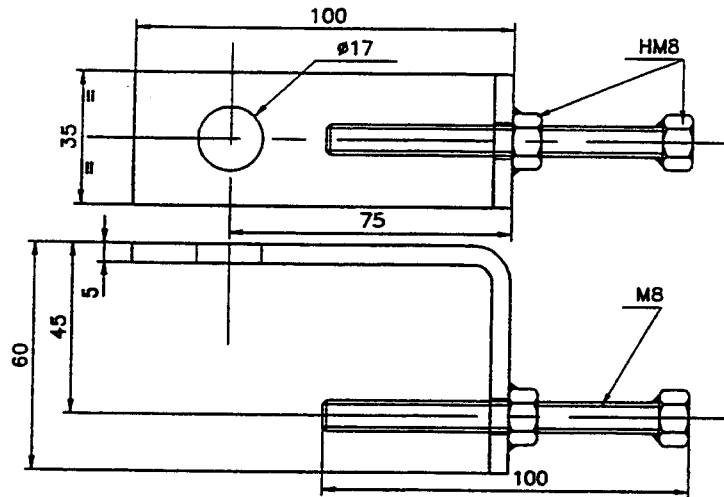





**Hydraulics** - *Dynashift control*

9 K01 *Dynashift control*

CONTENTS

-	<b>General</b> _____	2
A.	<b>Ratios explanation</b> _____	5
B.	<b>Piston pressure check</b> _____	6



9K01.2

## 6100 SERIES TRACTORS

**Hydraulics - Dynashift control****General**

The system control assembly comprises of the three main parts (Fig. 1) :

- **The distribution unit (1)** mounted on the right side of the gearbox can be fitted in two different versions :

**A . Pressure loaded** : The distribution unit consists of two separate sections, one for clutch control and the other controlling the Dynashift.

**B . Spring loaded** : The distribution unit controls only the Dynashift system.

Every version has two internal oilways A and B (Fig. 2 and 3) allowing the oil to circulate from one solenoid valve to the other.

- **The solenoid valves (2)** are screwed into the distribution unit, they include:

- . the lower solenoid valve EV1 with four ports and two positions.
- . the upper solenoid valve EV2 with three ports and two positions.

- **The accumulator (3)** mounted on the distribution unit, on the inlet line, enhances the oil flow to fill the Dynashift unit piston chambers when necessary. Thus piston reaction is maintained.

Make	:	Olaer
Type	:	1/20
Capacity	:	1 litre
Gas	:	Nitrogen
Pressure	:	9 ± 1 bar (must be checked every 6 month, with engine stopped)

**Note: When the engine is stopped, the accumulator maintains a pressure of 17 bars for a short period. If immediate maintenance action is necessary on the system, proceed with caution.**

Two test couplers may be fitted to check the pressure in the piston chambers (Fig. 8).

The distribution unit oil is supplied by the pipe (4). The return oil, from the piston chambers goes directly to the selector cover.

**Lubrication**

The oil flow coming from the cooler lubricates the mechanical elements of the Dynashift, reverse shuttle unit, gearbox and P.T.O. shaft which pass through the transmission (see section 5 A01).

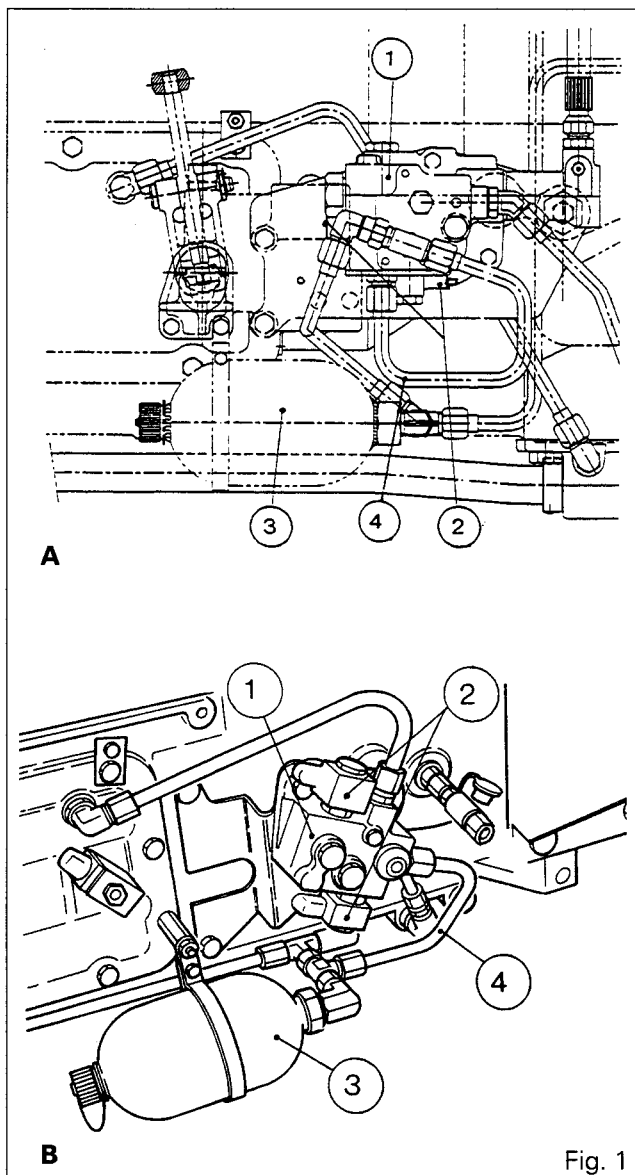
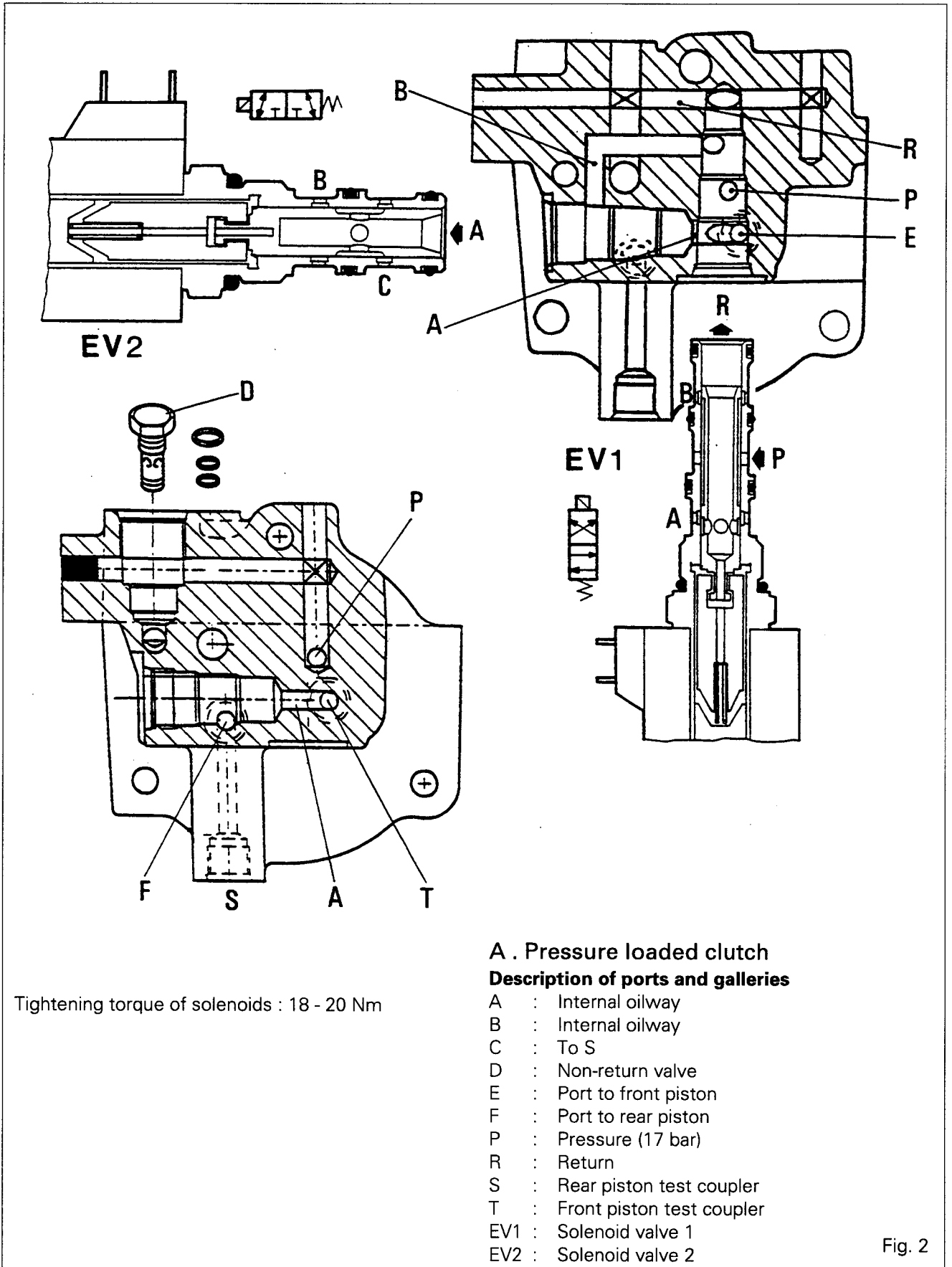

Fig. 1



# Hydraulics - Dynashift control

9K01.3



Tightening torque of solenoids : 18 - 20 Nm

Fig. 2



9K01.4

6100 SERIES TRACTORS



Hydraulics - Dynashift control

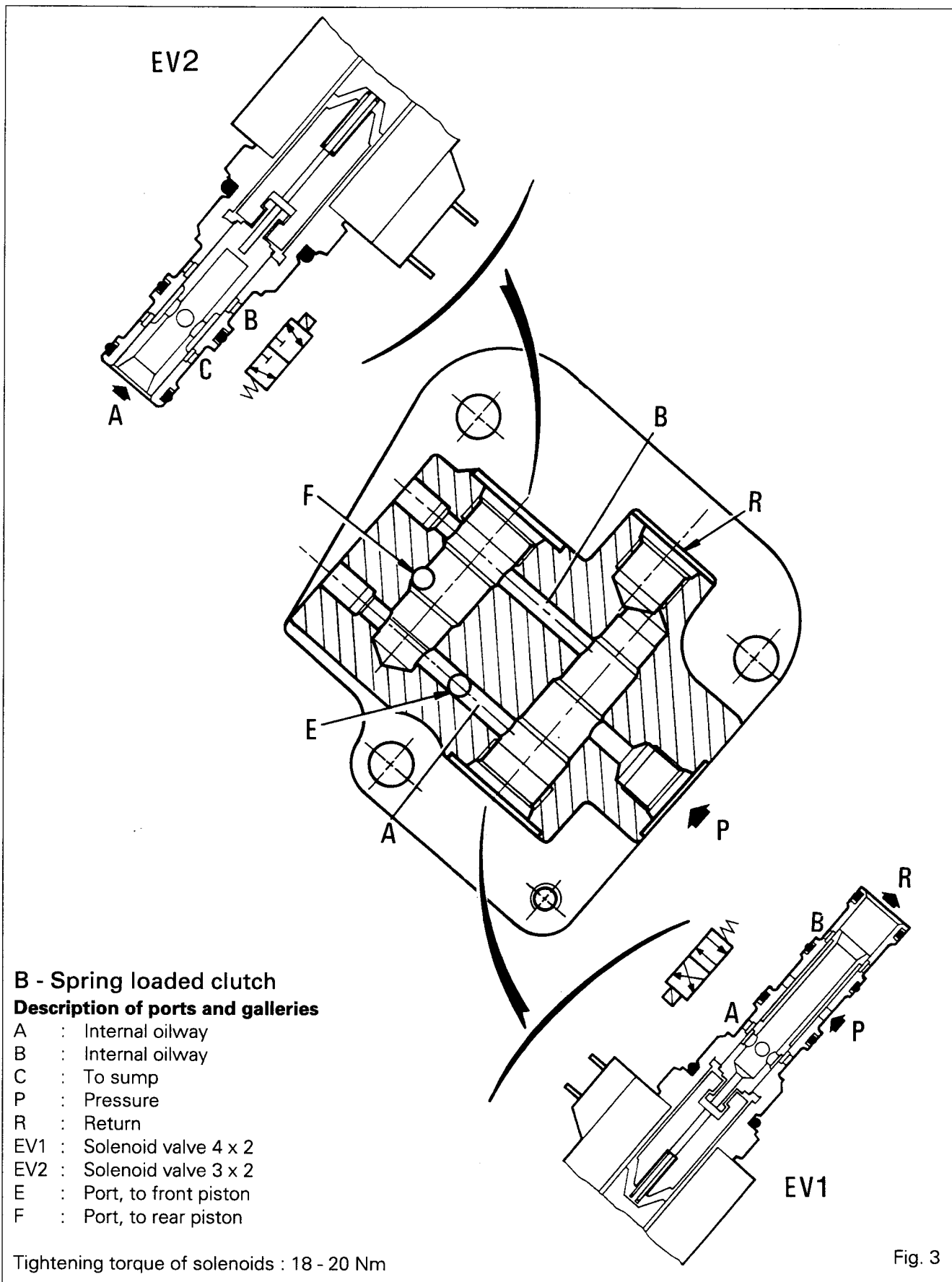

Fig. 3



## Hydraulics - Dynashift control

### A . Ratios explanation

Refer to section 5 B03 for the theoretical operation and the mechanical explanation of the ratios.

#### Ratio A (Fig. 4)

Solenoid valve EV1 is supplied, thus allowing oil under pressure to reach gallery A. This gallery directs the oil to the front piston via orifice E, and also, to solenoid valve EV2. Since EV2 is in neutral position, the oil can circulate through the spool valve and orifice F to the rear piston chamber. Both pistons are thus under pressure.

#### Ratio B (Fig. 5)

A gear change from A to B is obtained when both solenoid valves are supplied. The oil flow to the rear piston is thus interrupted. The rear piston is pushed back by springs which send oil back into gallery B. This gallery communicates with the sump via solenoid valve EV1.

#### Ratio C (Fig. 6)

A gear change from B to C is obtained by interrupting the electrical supply to solenoid valve EV1, solenoid valve EV2 remains energized. Gallery A is no longer under pressure but is connected to the sump. Consequently, the front piston can return to neutral position.

Gallery B is under pressure. The oil circulates to the rear piston through solenoid valve EV2.

#### Ratio D (Fig. 7)

Ratio D is obtained by cutting the electrical supply to EV2. The two pistons are connected to the sump by gallery A.

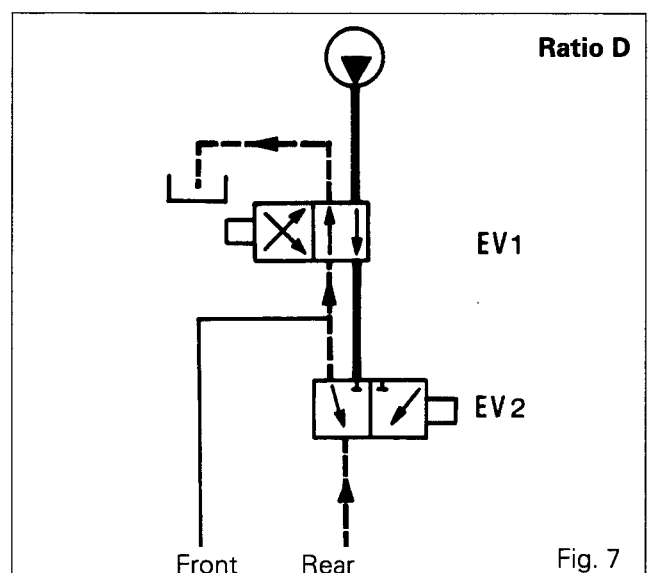
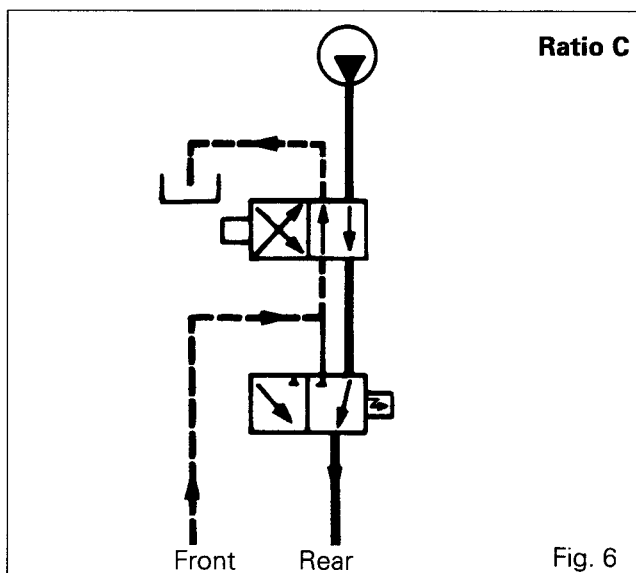
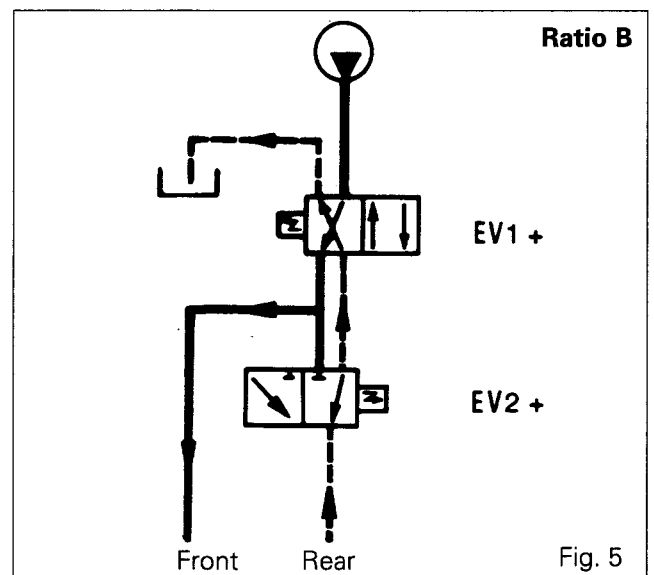
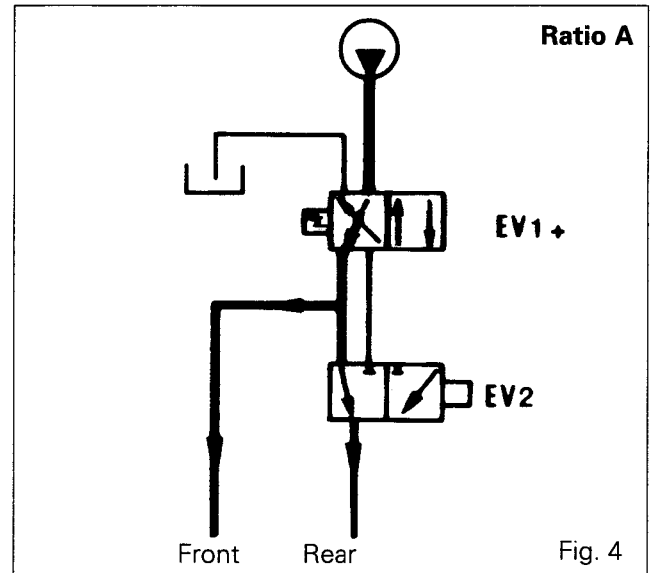





9K01.6

## 6100 SERIES TRACTORS

**Hydraulics - Dynashift control****B . Piston pressure check (Fig. 8)**

1. Remove plugs (1) from the distribution unit.
2. Screw on two male couplers (2) and (3), ref. 3384387 M1, and connect them to couplers ref. 3582045 M1, connected to pressure gauges with a capacity of 30 bar approx.
3. Start the engine.
4. Operate the lever under the steering wheel to select each ratio (A, B, C, D).
5. Check that the pressures are correct in accordance with the following table.

Ratio	Front piston coupler (7)	Rear piston coupler (8)
A	17 bar	17 bar
B	17 bar	0
C	0	17 bar
D	0	0

6. If the pressures are not correct, check the displacement of the solenoid spool valve or refer to the electrical tests.

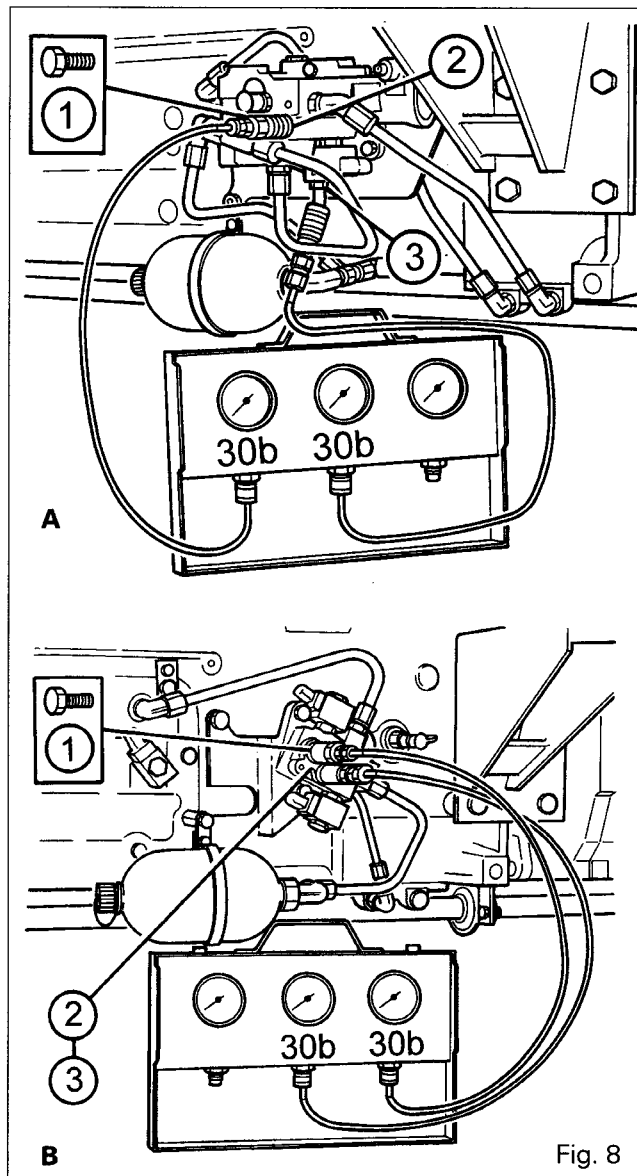

Fig. 8



**Hydraulics - Tests**

9 L01 *Hydraulic tests*

CONTENTS

-	<b>Preparation</b> _____	<b>2</b>
A.	<b>High-flow circuit</b> _____	<b>2</b>
B.	<b>Low-flow circuit</b> _____	<b>5</b>



9L01.2

## 6100 SERIES TRACTORS

**Hydraulics - Tests****Preparation**

Before beginning the tests, the engine should be run to bring the oil temperature up to a minimum of 60°C (140°F).

The following equipment is recommended for the tests described in this section. This equipment is available through the MF network:

- MF 3001: Pressure gauge kit
- MF 3002: Hoses and unions kit
- MF 3003: Flowmeter assembly
- 3582045 M1: Hydraulic coupler

Otherwise, use suitable equivalent equipment.

**In all cases, make sure of the direction of flow of the oil in order to avoid damaging the flowmeter. Choose pressure gauges, hoses and unions of sufficient capacity and strength.**

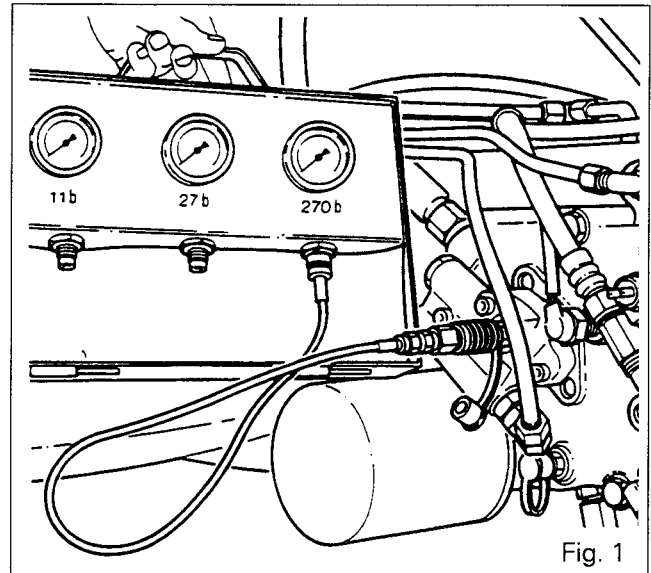

Fig. 1

**A. High-flow circuit (Fig. 3)**

**Note: The ratio of the pump drive gears (high and low flow) has been modified as from serial number D125027 in order to obtain an output of 57 l/mn at a maximum speed.**

**1. High-pressure safety valve**

Fit a pressure gauge with a coupler 3582045 M1 (Fig. 1) on the diagnostic connector on the trailer brake valve (if fitted) or on the blanking plate fitted on the cover. Run the engine at 2,200 rpm. Operate an auxiliary spool valve to open the valve. Read:

**P1 = 185 bar (+ 15 bar - 5 bar).**

At 1,000 rpm, the pressure should not drop.

If necessary, adjust the valve with shims (see Section 9I01, Part C).

**2. Pump output**

Connect the flowmeter pressure inlet to a quick coupler on a spool valve other than the one supplied by the flow divider.

Connect the return directly to the housing via the transmission filler port. It is also possible to connect the return to accessory 3467953M91 which allows direct connection with the housing (Fig. 2).

Check that the flowmeter valve is fully open and connect a suitable pressure gauge to the flowmeter diagnostic connector as shown in Fig. 1.

Operate the relevant spool valve and check that the following minimum values are obtained:

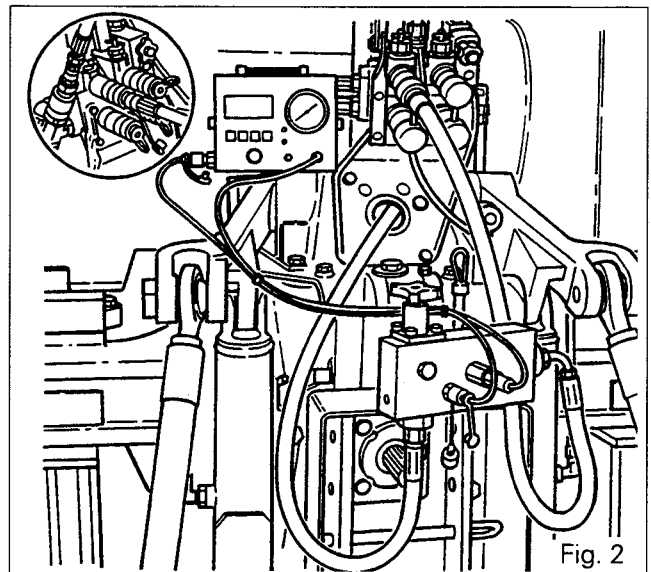

Fig. 2

Engine speed (rpm)	Q1:L/mn	Q1:L/mn	P2:bar
	→D125026	↳D125027	
2,200	47,7	53,5	0
2,200	47,7	53,5	0



High-flow circuit

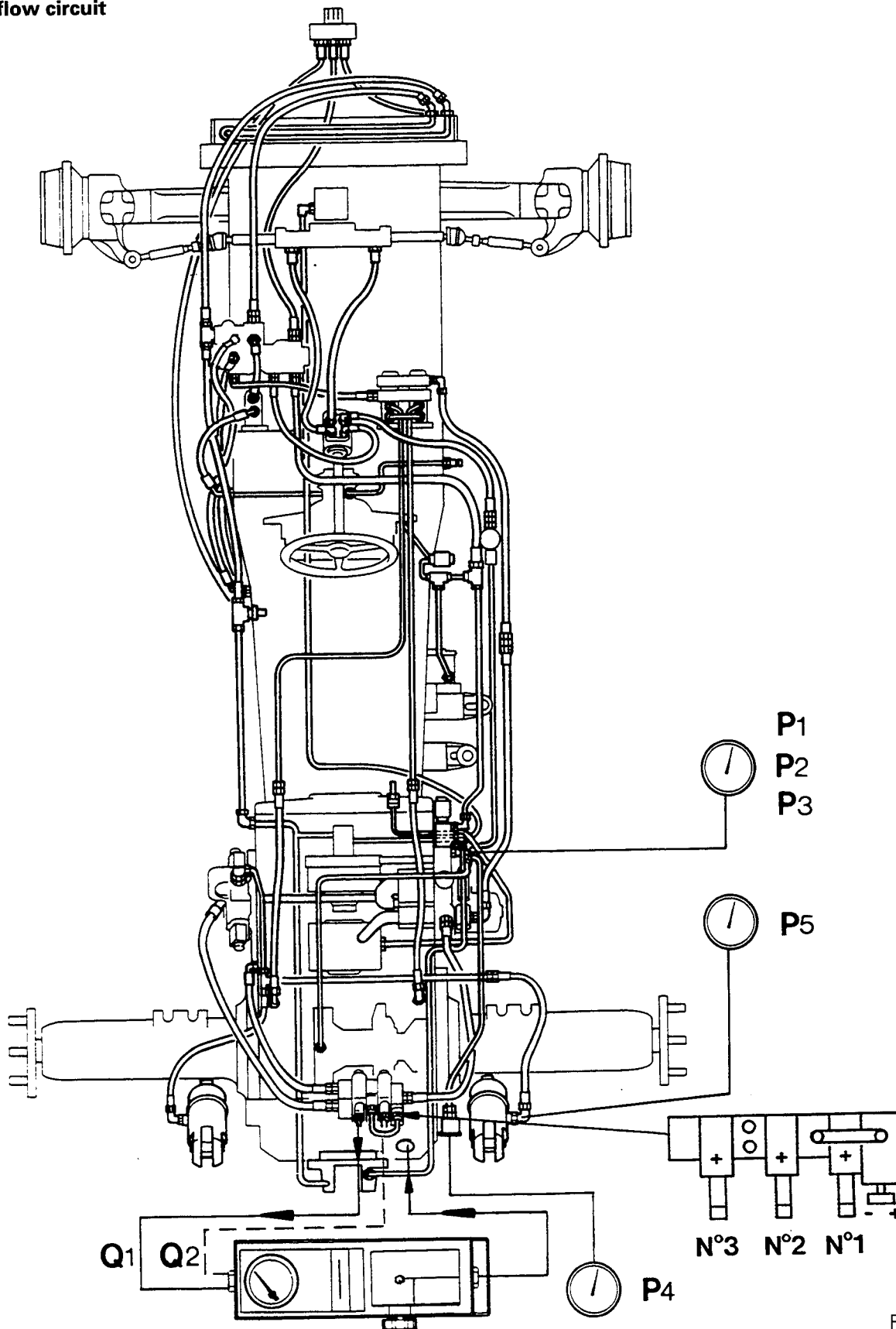

Fig. 3



9L01.4

## 6100 SERIES TRACTORS

**Hydraulics - Tests****3. Flow divider (if fitted)**

Connect up the flowmeter as described in Part A.2 but on spool valve No. 1 (Fig. 3).

Operate the spool valve and control the flow through the flow divider by operating the regulating valve (Fig. 4).

Engine speed 2,200 rpm	P2: 0 bar
Q2 l/mn                      max.	40

**4. Auxiliary spool valve with automatic return to neutral point**

Connect the flowmeter onto the corresponding spool valve as described in Part A.2.

Run the engine at 2,200 rpm and operate the spool valve. Release the lever and gradually close the flowmeter valve until the lever returns to the neutral point.

The triggering pressure must be:

**P3 = 135 to 160 bar**

**5. Trailer brake (if fitted)**

Connect a pressure gauge to the trailer brake valve.

Run the engine at 2,200 rpm.

With the brake pedals coupled together, gradually apply force. The pressure reading must gradually increase to reach:

**P4 = 130 to 150 bar max.**

**6. Lift shock valve**

Uncouple the feed hoses from the ram and connect them to a hand-operated calibrating pump.

With the engine stopped and the lift control valve in the neutral position, apply pressure in the circuit. Note the opening pressure:

**P5 = 200 to 210 bar**

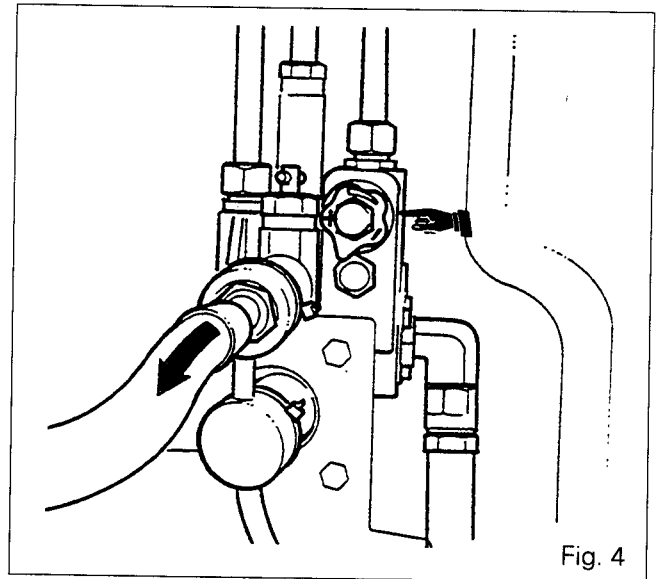

Fig. 4



# Hydraulics - Tests

## B. Low-flow circuit (Fig. 6)

### 1. Pump output

Connect the flowmeter between the distribution valve the hose (1) of the 1.5 bar valve, as shown in Fig. 5.

**Caution: Make sure that the flowmeter calibrating valve is fully open.**

Also connect a pressure gauge to the distribution valve (outlet 4 fitted with a plug).

The following minimum values must be obtained:

Engine speed rpm	Q3: l/mn → D125026	Q3: l/mn → D125027	P6: bar	Obs.
2,200	25,4	26,7	16,4 à 19	Steering at rest
1,000	11	12	16,4 à 19	Steering at rest



During the tests, the rear axle assembly must not be installed on blocks with the front axle engaged (4WD).

### 2. Checking for leaks on clutches and receiving components

To check the reference flow Q3, the front axle must be **engaged** (no flow to clutch, warning light on), the range lever must be in the Tortoise position and the Dynashift lever must be in position D. On tractors equipped with a Speedshift, the lever must be placed in position C (30 km/h tractors) or in position D (40 km/h tractors) according to the version.

Remain connected as in B1. Check the reference flow Q3 at 1,000 rpm.

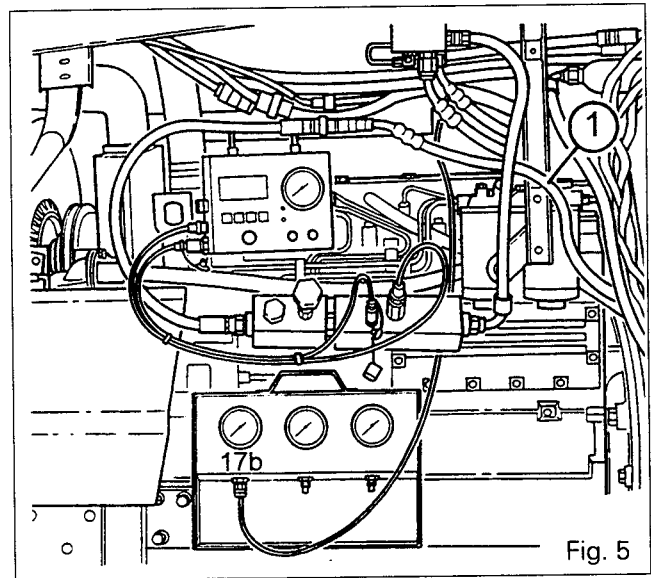

Fig. 5

Operate each function **separately** and note flow Q4. The difference between Q3 and Q4 represents the leak observed which must not exceed the values shown in the guide table.

Example: PTO clutch

Q3 = 13 l/mn Q4 = 11.5 l/mn Leak = 1.5 l/mn, OK

Q3 = 13 l/mn, Q4 = 10.8 l/mn, Leak = 2.2 l/mn, greater than permissible leak

**Note: Before checking the next function and to avoid falsifying flowrate Q4, return the control lever for the component under test to the neutral point or to the position specified above.**

Pressure P6 must stay at 17 bars when all the clutches and receiving components are operated.

	PTO clutch and brake	Diff. lock	Front PTO	Dynashift ABCD	Speed-shift	Range	Clutch Front axle	Pressure-loaded clutch	Electro-hydraulic reversing control
			Optional	As per version					As per version
Reference flow Q3							*	◇	
Flow reading Q4							*	◇	
Flow observed Q3 - Q4 l/mn									
Permissible flow l/mn	1.5	2	3	0	3	2	2	3.5	0
Pressure P6 (bar)	16.4 - 19								



## 6100 SERIES TRACTORS



9L01.6

### Hydraulics - Tests

- \* Q3 = Front axle **engaged** (no flow to clutch)
- \* Q4 = Front axle **disengaged** (flow to clutch)

**On tractors 6170 to 6190** (Pressure-loaded engine clutch)

- ◊ Q3 = Pedal pressed fully down (no flow to clutch)
- ◊ Q4 = Pedal released (flow to clutch)

Leaks from single-piston systems can be detected using the values stated above. For dual-piston functions (power take-off and differential lock), a further test is required:

- Disconnect one of the pistons and block off its supply. Check whether the leak disappears.

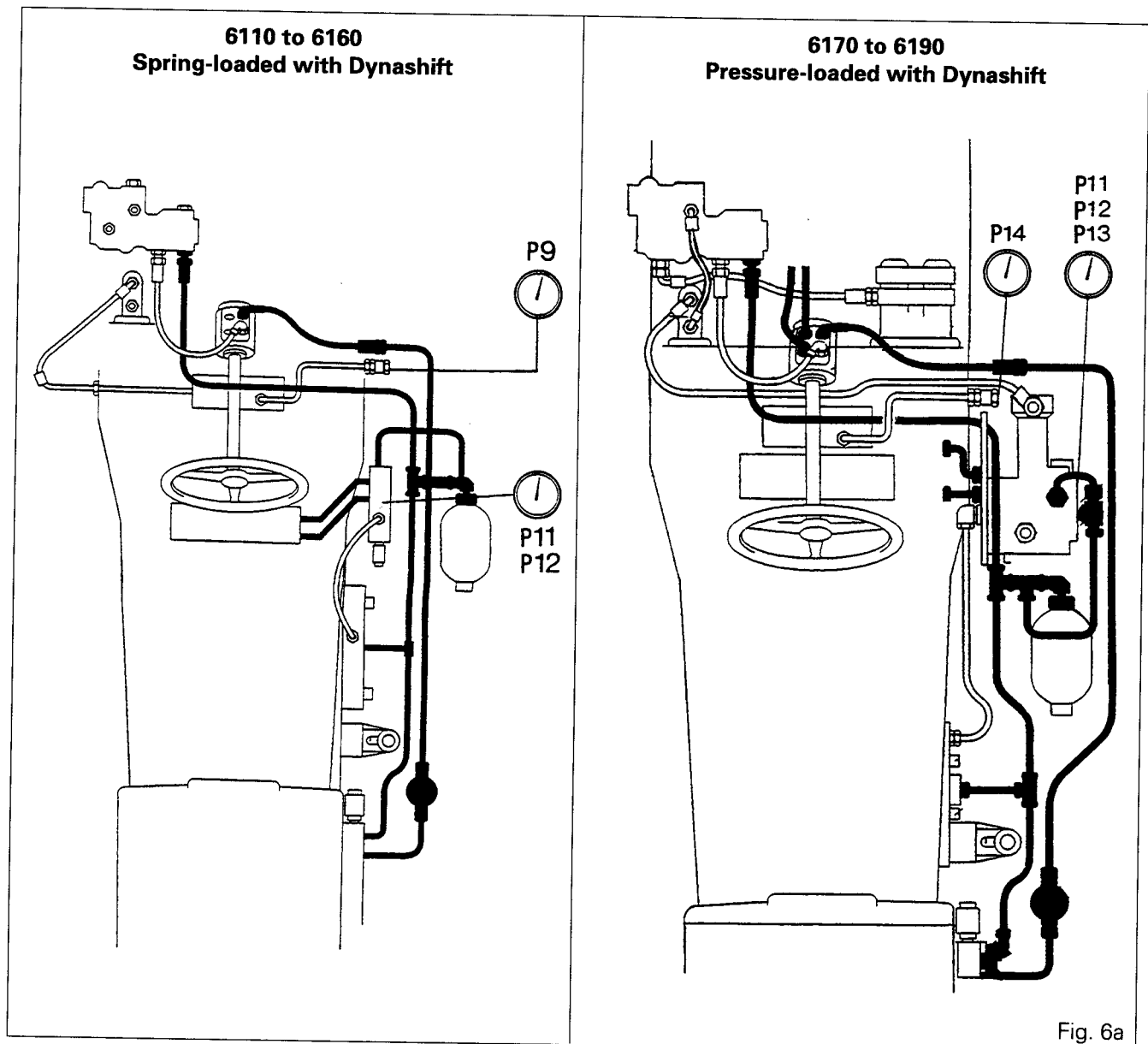



**Hydraulics - Tests**

9L01.7

Low-flow circuit

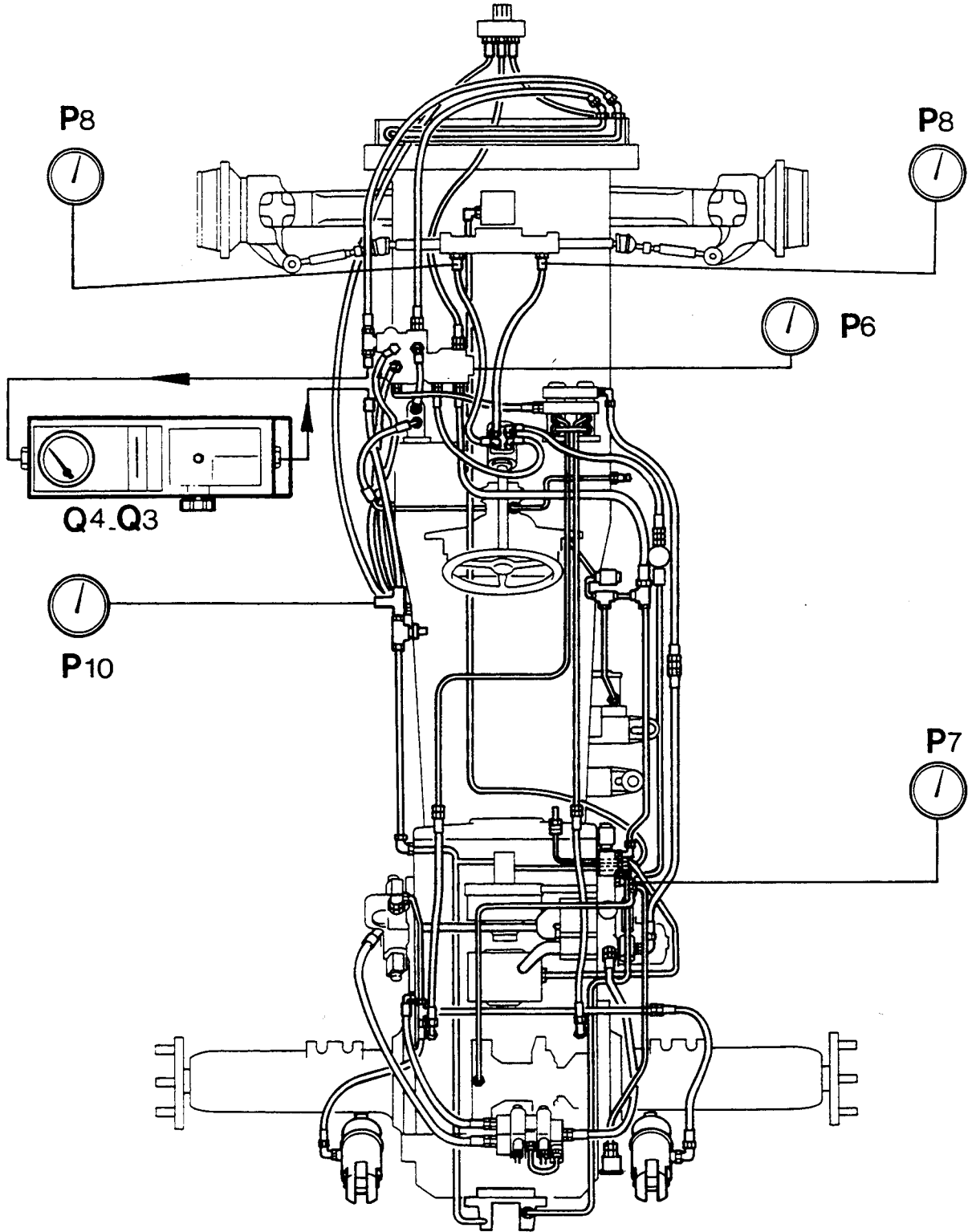

Fig. 6b





9L01.8

## Hydraulics - Tests

### 3. Supply to steering distribution valve (Orbitrol)

Connect a pressure gauge to the diagnostic connector on the right-hand hydraulic cover, as shown in Fig. 7. Turn the steering wheel as far as it will go and read:  
**P7 = 170 bar** at 1,000 rpm as well as at 2,200 rpm.

### 4. Supply to steering ram

Connect a pressure gauge as a bypass on each steering ram hose.

With the steering at rest, read:

**P8 = 17 bar.**

Turn the steering wheel. Pressure **P8** must be established at between **17 and 170 bar** on the ram supply side.

The pressure on the return line must be 17 bar.

Check for leaks from the steering circuit.

Run the engine at 1,000 rpm.

Apply full steering lock on the wheels, applying a torque of 4 Nm on the steering wheel. The steering wheel must not turn faster than 2 revolutions per minute.

If the steering wheel does turn faster than 2 revolutions per minute, disconnect the pipes supplying the rams and blank the two ports.

Apply the same torque on the steering wheel. If it turns slower than 2 revolutions per minute, there is a leak from the ram.

### 5. Clutch release bearing

#### Tractors 6110 to 6160 - spring-loaded engine clutch

Fit a pressure gauge equipped with a coupler 3582045 M1 to the bleed point on the right-hand side of the gearbox (Fig. 8)

**Caution:** As the pressure may reach approximately 18 bar when the pedal is depressed, it is essential to connect the pressure gauge after starting up the engine.

Check the pressure:

- Std tractors up to S/N D086000
- Step nose tractors up to S/N D115016

**P9 = 1,5 bar**

From S/N D086001 (std) and D115017 (step nose) a new block and a valve fitted on the 17 bar distribution valve limit the pressure towards the master cylinders.

**P9 = about 1 bar**

### 6. Lubricating pressure (transmission)

Connect a pressure gauge on the tee on the valve on the left of the gearbox. **Check the reading: P10 = 1.5 bar max.**

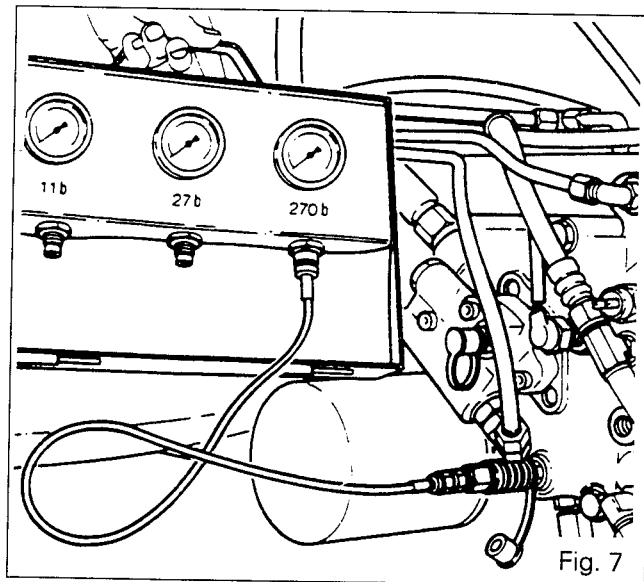

Fig. 7

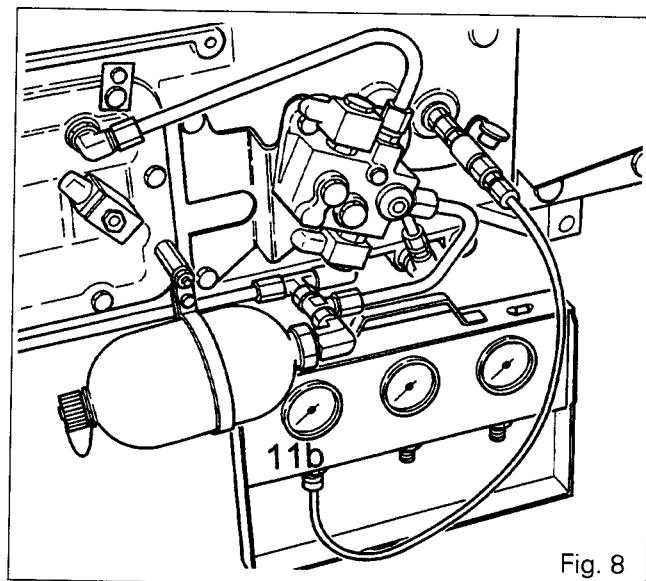

Fig. 8



## Hydraulics - Tests

### 7. Checking of Dynashift piston pressure

Remove the guard preventing access to the connectors (30 km/h tractors).

Remove the plugs **(1)** from the distribution unit.

Screw in two male connectors **(2) - (3)**, ref. 3384387M1, and couple them with the diagnostic connectors connected to pressures gauges with a capacity of about 30 bar (Fig. 9).

Start up the engine.

Operate the lever under the steering wheel to select each gear ratio (A, B, C and D).

Check that the pressures are correct, in accordance with the table below:

Ratio	Front piston <b>(2)</b> <b>P11</b> (bar)	Rear piston <b>(3)</b> <b>P12</b> (bar)	EV1 (V)	EV2 (V)
A	17	17	12	0
B	17	0	12	12
C	0	17	0	12
D	0	0	0	0

If the pressures are not correct, check the movement of the spools of the solenoid valves (EV) or see the documentation on electrical tests.

Reinstall the guard and seal the attaching screw with lead.

### 8. Checking of modulation pressures and lubrication of pressure-loaded clutch - Tractors 6170 to 6190

Connect a pressure gauge to the diagnostic connector on the clutch valve located on the right-hand side of the gearbox, as per Fig. 10, to check **P13**.

- Operate the pedal to engage or disengage the clutch.

Engine speed (rpm)	<b>P13</b> (bar) disengaged	<b>P13</b> (bar) engaged
1,000	0	17
2,200	0	17

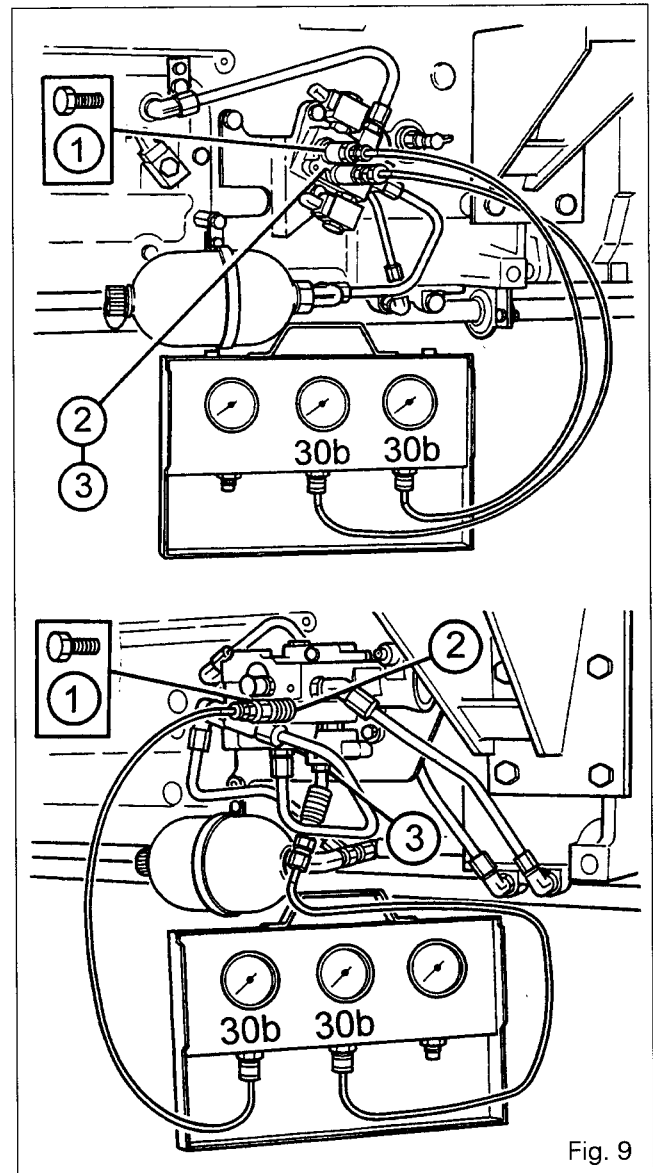

Fig. 9



# 6100 SERIES TRACTORS



9L01.10

## Hydraulics - Tests

### Modulation pressure

The clutch valve gives a modulation between 11 bars and 0 bar. This modulation corresponds to a pedal travel extending between 32 mm ± 1 from the high stop position and 25 mm ± 1 before the pedal low stop position (the total travel being 150 mm).

- If the modulation travel is offset with respect to the pedal travel, bleed the control using the bleeder (2) located at the end of the valve (see Section 4A01, Part E).

### Lubrication circuit

Connect a pressure gauge onto the diagnostic connector located on the right-hand side of the gearbox (Fig. 11) to check **P14**.

Operate the pedal to disengage or engage the clutch.

Engine speed (rpm)	P14 (bar) disengaged	P14 (bar) engaged
1,000	2	0.4
2,200	3	1.2

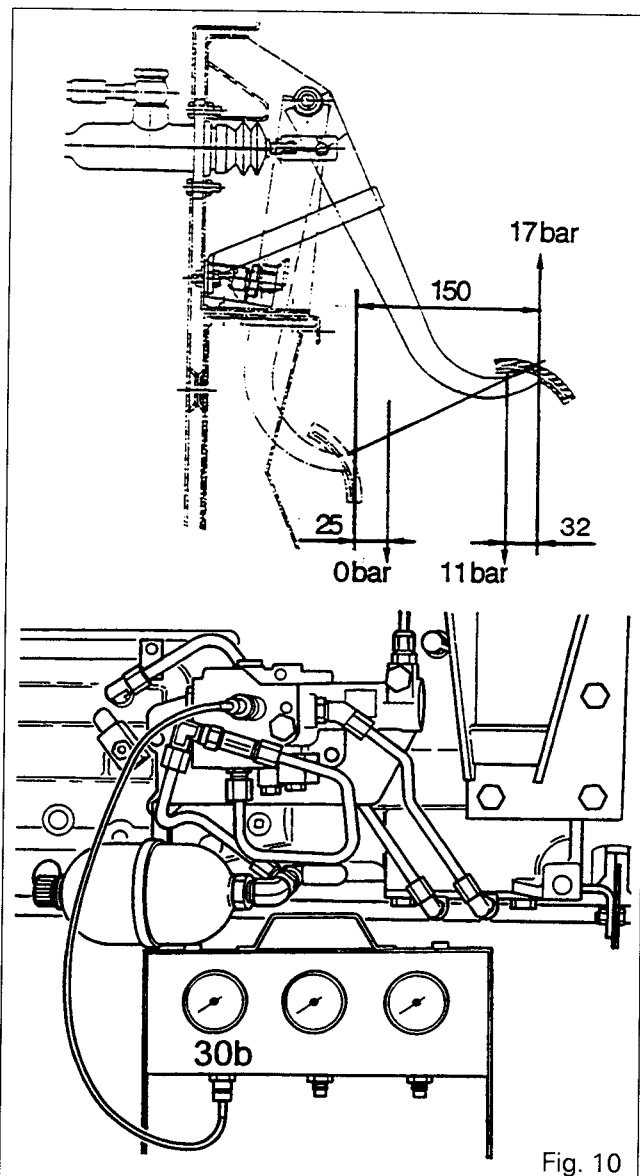

Fig. 10

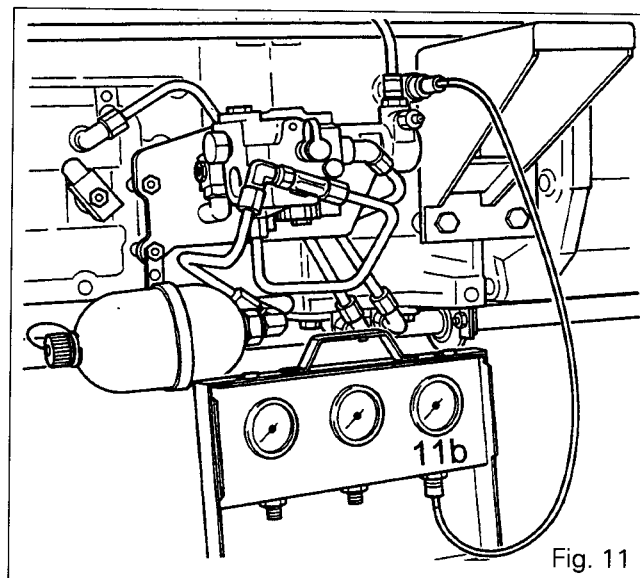

Fig. 11



# Hydraulics - Tests

## 9. Checking constant level in the front PTO housing (if fitted)

- Using a probe, measure the outlet flowrate **Q5** (Fig. 12) and the inlet flowrate **Q6** after the restrictor (Fig. 13).

Engine speed (rpm)	<b>Q5</b> l/mn disengaged	<b>Q6</b> l/mn engaged
2,200	0.75	0.75

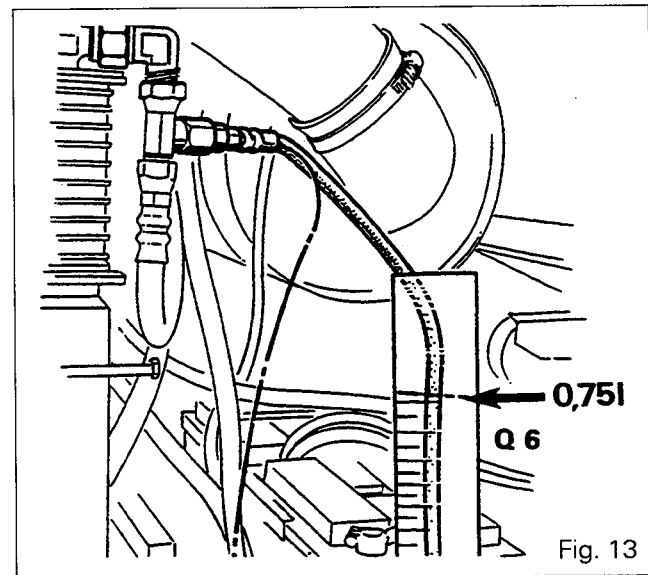
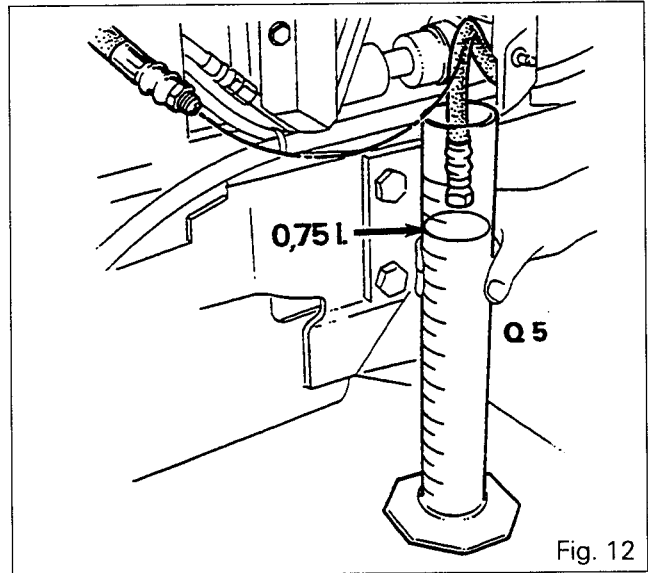





*9 M01 General description*

CONTENTS

A.	General _____	2
B.	Principle _____	2
C.	Layout of parts _____	3
D.	Circuit diagrams _____	5
E.	Identification of ports _____	6



9M01.2

## 6100 SERIES TRACTORS



# Hydraulics - Closed centre

### A . General

6100 series tractors with six-cylinder engines can, on option, be equipped with a hydraulic circuit of the closed centre type with controlled flowrate and pressure. This is made up of two separate HP and LP circuits supplied by a variable-displacement pump which is, itself, supplied by a booster pump.

Both pumps are driven by the external teeth on the PTO clutch.

The booster pump installed on the left-hand cover sucks the oil, through a strainer, into the common reservoir formed by the centre housing and the gearbox. The booster flow is then conveyed to the right-hand cover and passes through the main filter before flowing to the variable-displacement pump, and to the cooling and gearbox lubricating circuit. The booster pressure is maintained by a valve mounted on the right-hand cover and calibrated at 5 bars.

The variable-displacement pump provides supply to either one or two override units installed on the left-hand cover, as applicable:

- one unit for tractors without trailer braking,
- two units for tractors with trailer braking.

The first override unit ensures supply to:

- the steering system (or the steering system and trailer braking) as first priority,
- the 17-bar circuit as second priority.

The second override unit, if fitted, shares its first priority between the steering system and the trailer brake circuit. When supply has been provided for these priority functions, the remaining flow is available for the lift control valve and auxiliary spool valves.

It is impossible for the whole output from the variable-displacement pump to be absorbed by the override units.

All the pilot signals from the various HP valves are sent to the override units and then transmitted to the variable-displacement pump controller.

The controller responds to the pilot signal corresponding to the function requiring the highest pressure.

### Characteristics of components

#### Suction strainer (27)

- Cartridge type
- Filtration threshold: 150  $\mu$

#### Booster pump (5)

Trademark: Rexroth - Sigma

Capacity: 60 cm<sup>3</sup> per revolution

Output: 165 litres/mn at 2,200 rpm

#### Main filter (40)

- Filtration threshold: 15  $\mu$
- With bypass
- With differential pressure switch

#### Safety valve (58)

- Calibration: 22 bars
- Fitted on the LP circuit

#### Safety valve (52)

- Calibration: 5 bars
- Hydraulic receivers not used: resupply of booster pump

#### 5-bar switch (44) (Clogging indicator)

- Opening at 3 bars - Closing at 2 bars
- Fitted in parallel with the filter
- Connected to the indicator light on the dashboard

#### Variable-displacement pump (29)

- Trademark: Brueninghaus
- Type: Axial pistons (9)
- Capacity: variable from 0 to 45 cm<sup>3</sup> per revolution
- Output: 0 to 105 litres/mn at 2,200 rpm
- Pressure: 22 bars min.  
200 bars max.
- Lubrication: internal, with return to housing

### B . Principle

The principle of the closed centre hydraulic system is to limit the power absorbed by the engine. If no hydraulic slave device is actuated, no output is discharged from the variable-displacement pump. When one function is engaged, the pump supplies only the output required for that function.

**Note : When the housing is drained, the main filter is replaced or any servicing operation resulting in the intake of air is performed on the circuit, the hydraulic circuit must be primed.**

**Disconnect the electrical stop device on the injection pump and turn the engine with the starter motor until the 5-bar pressure indicator light goes out on the dashboard.**



C . Layout of parts

Tractors 6170 - 6180 - 6190

Pressure-loaded clutch with Dynashift and electro-hydraulically controlled selector cover (according to option)

List of parts

- (1) Front differential lock
- (2) Steering ram
- (3) Left-hand cover
- (4) Hydrostatic steering unit (Orbitrol)
- (5) Booster pump
- (6) Dynashift
- (7) Hare/Tortoise solenoid valve
- (8) PTO clutch
- (9) 4WD clutch
- (10) Rear differential lock
- (11) PTO brake
- (12) Front PTO (if fitted)
- (13) Cooler
- (14) Clutch master cylinder
- (15) Brake master cylinders
- (16) Pressure control valve, 17 bar
- (17) Steering override valve
- (18) Hare/Tortoise solenoid valve
- (19) Differential lock solenoid valve
- (20) PTO solenoid valve
- (21) PTO brake solenoid valve
- (22) 4WD solenoid valve
- (23) Front PTO solenoid valve (if fitted)
- (24) LP switch
- (25) Right-hand and left-hand brakes
- (26) Pump suction pipe
- (27) Suction strainer, 150 micrometres
- (28) Lubrication switch
- (29) Variable-displacement pump
- (30) Pressure relief valve
- (31) Trailer brake valve
- (32) Trailer brake connector
- (33) Auxiliary spool valves
- (34) Lift control valve
- (35) Lift ram
- (36) Valve 1.5 bar
- (37) LP diagnostic connector
- (38) Electrohydraulically controlled reverse shuttle piston (if fitted)
- (39) Lubrication: Speedshift or Dynashift (according to version) - Reverse shuttle - Gearbox - Power take-off and PTO brake
- (40) Main filter, 15 micrometres
- (41) Engine clutch and Dynashift control valve
- (42) Accumulator (Dynashift version)

- (43) Electrohydraulically controlled reverse shuttle solenoid valves (if fitted)
- (44) Clogging indicator
- (47) Pressure-loaded clutch
- (48) Pump controller
- (49) Gearbox
- (50) Override unit
- (51) Manifold
- (52) Safety valve 5 bar
- (53) Trailer brake unit (if fitted)
- (54) Right-hand hydraulic cover

On tractors with Speedshift, the "T" tube is replaced with a plug and a solenoid valve (45) is deleted.

Clogging indicator (44) screwed onto the filter head (40)

Activating pressure:  $2.4 \pm 0.3$  bar  
 Deactivating pressure:  $1.8 \pm 0.3$  bar  
 Connected to indicator light on dashboard  
 Tightening torque: 50 to 60 Nm

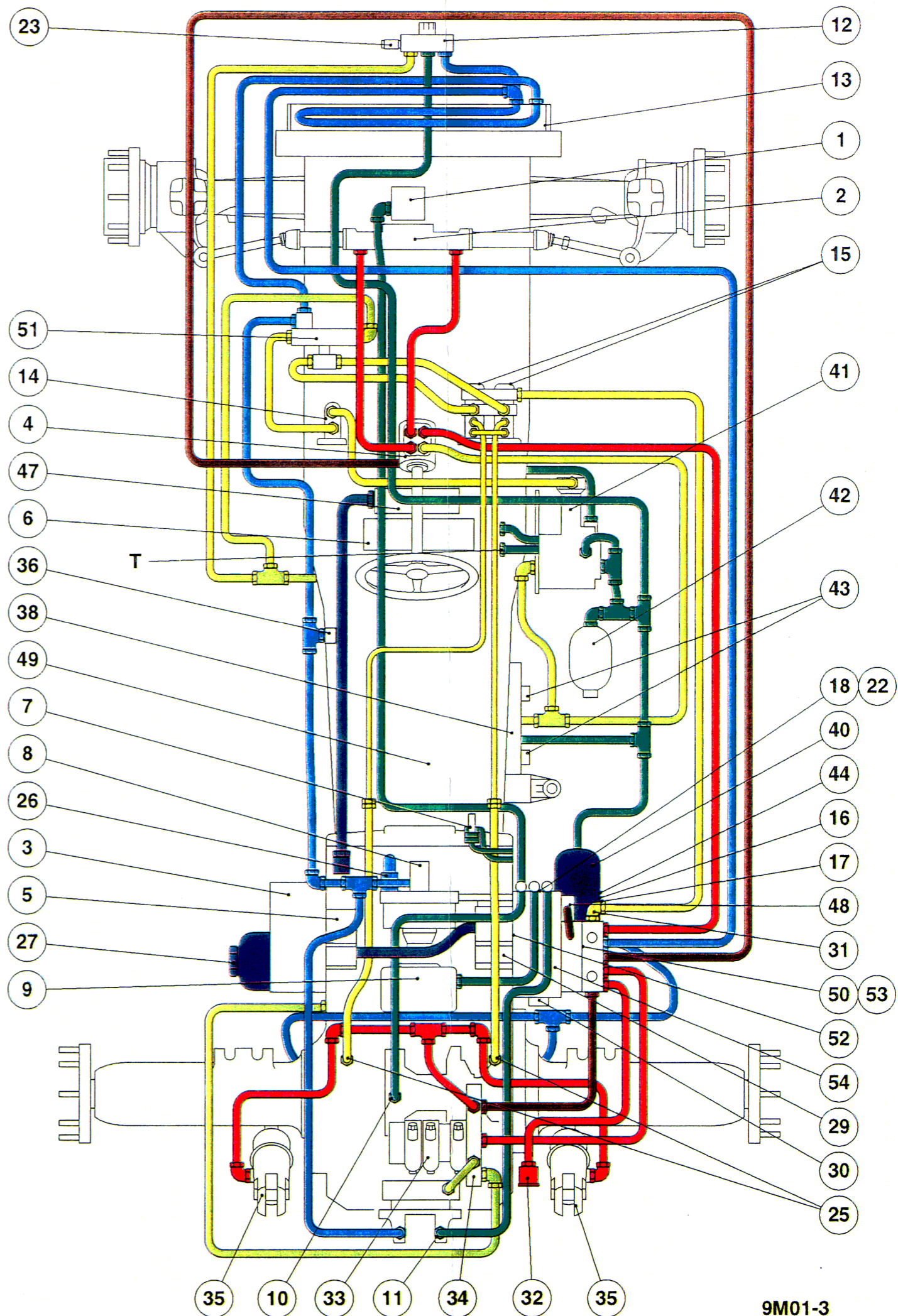
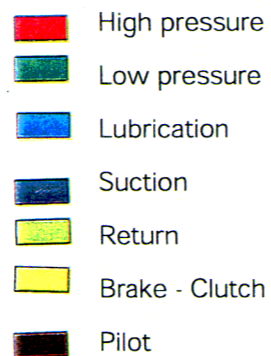





# Hydraulics - Closed centre

## Layout of parts Tractor 6160

Spring-loaded clutch with Speedshift and electrohydraulically controlled selector cover (according to option)

### Layout of parts Tractor 6160

- (45) Dynashift solenoid valves
- (46) Dynashift control valve
- (62) 3rd point support
- (63) Clutch (spring-loaded)

Spring-loaded clutch with Dynashift and electrohydraulically controlled selector cover (according to option)

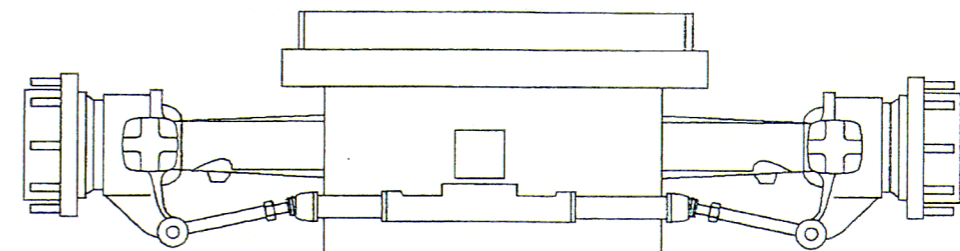
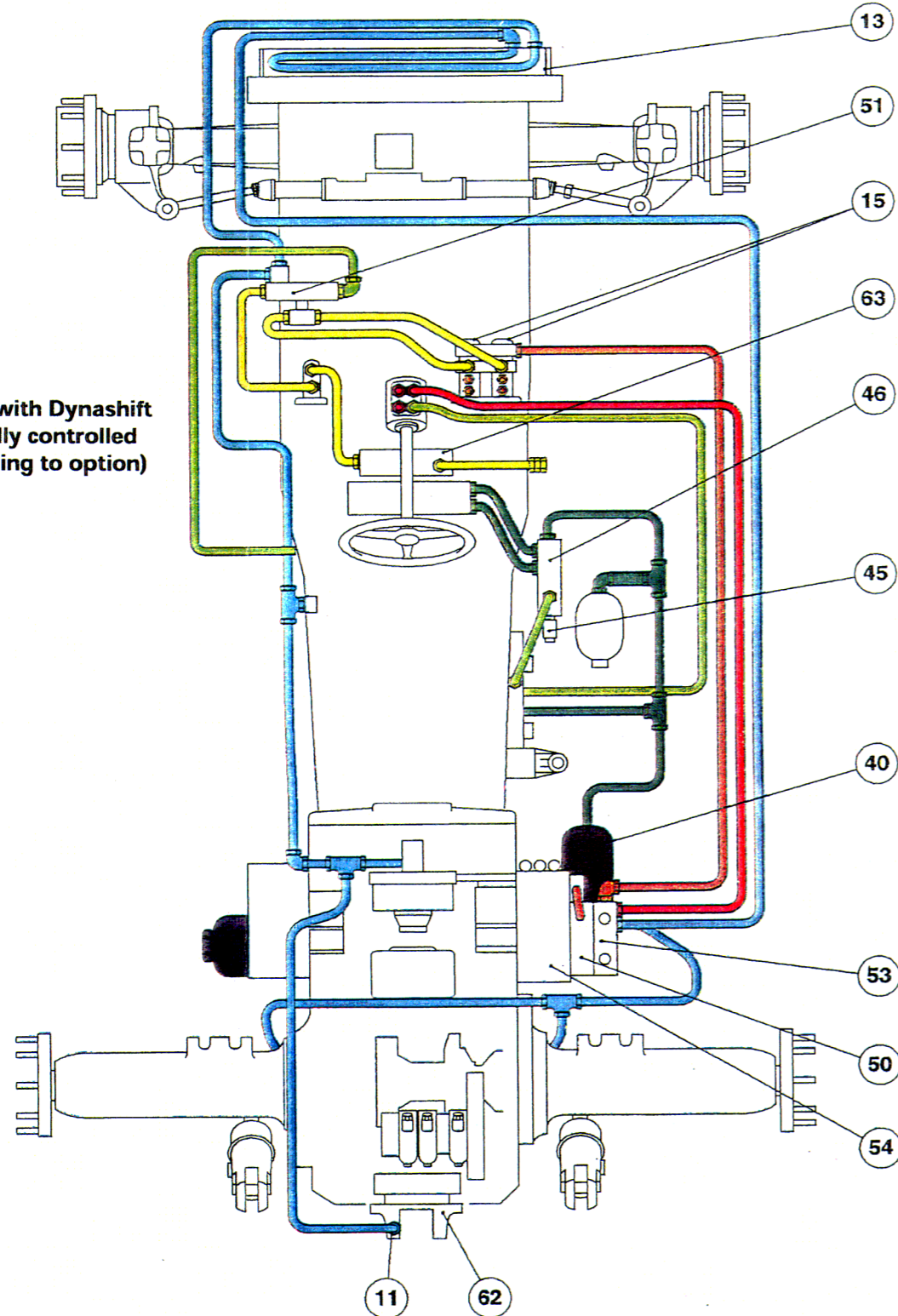

### Layout of parts Tractor 6160

- (64) Speedshift solenoid valves
- (65) Speedshift unit

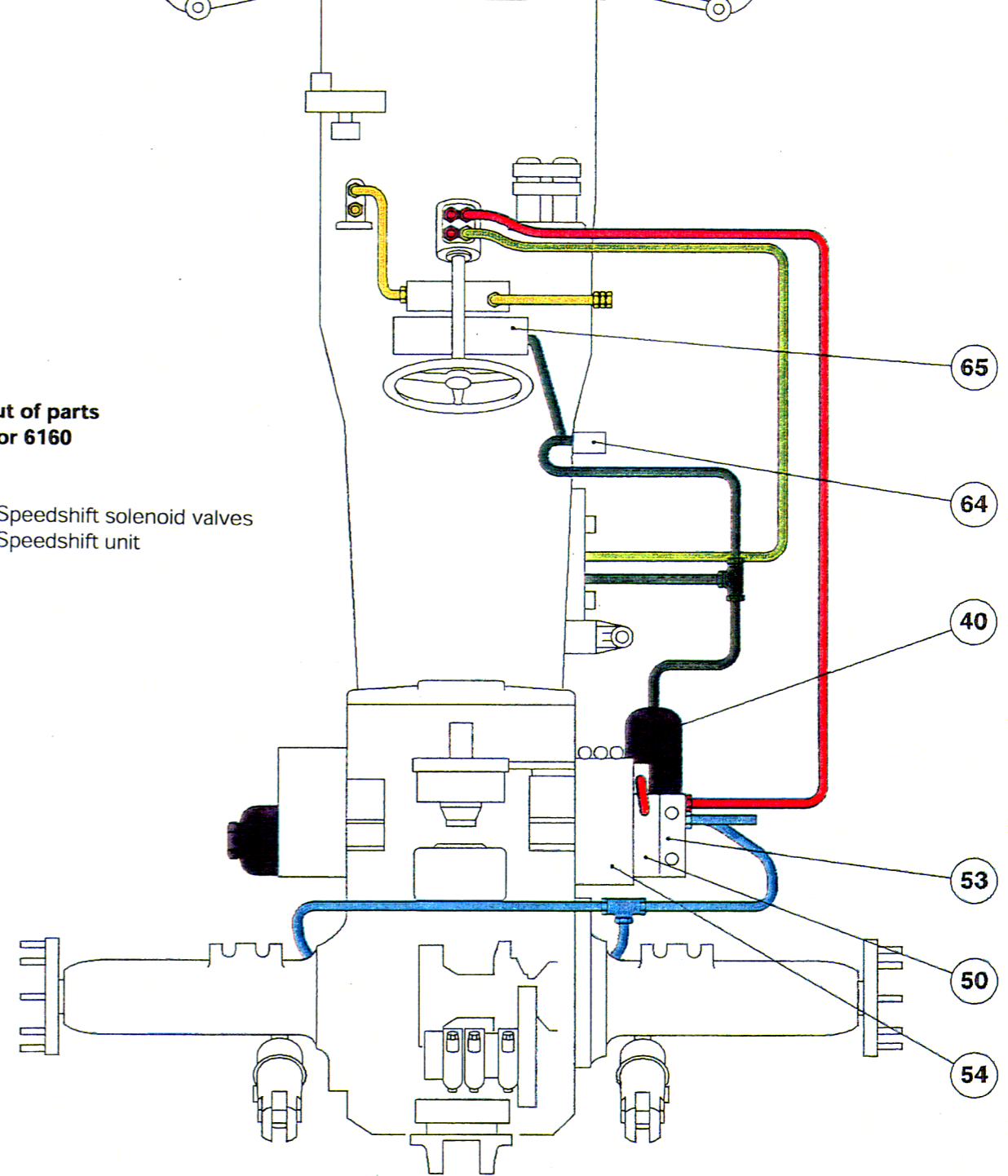





9M01.6

## 6100 SERIES TRACTORS

**Hydraulics - Closed centre****List of parts**

- (16) Pressure control valve, 17 bar
- (18) Hare/Tortoise solenoid valve
- (19) Differential lock solenoid valve
- (20) PTO solenoid valve
- (21) PTO brake solenoid valve
- (22) 4WD solenoid valve
- (24) LP switch
- (28) Lubrication switch
- (37) LP diagnostic connector
- (44) Clogging indicator
- (55) LS diagnostic connector
- (56) HP diagnostic connector
- (57) Lubrication diagnostic connector
- (58) Safety valve, 22 bar
- (59) Dynashift solenoid valves (EV1 and EV2)
- (61) Accumulator
- (63) Spring-loaded clutch
- (64) Speedshift solenoid valve
- (65) Speedshift unit

**E . Identification of pipes and ports**

- A : 4WD pipe
- B : LP pipe
- C : Front differential lock pipe
- D : PTO brake pipe
- E : Lubrication connection to cooler
- F : Rear differential lock pipe

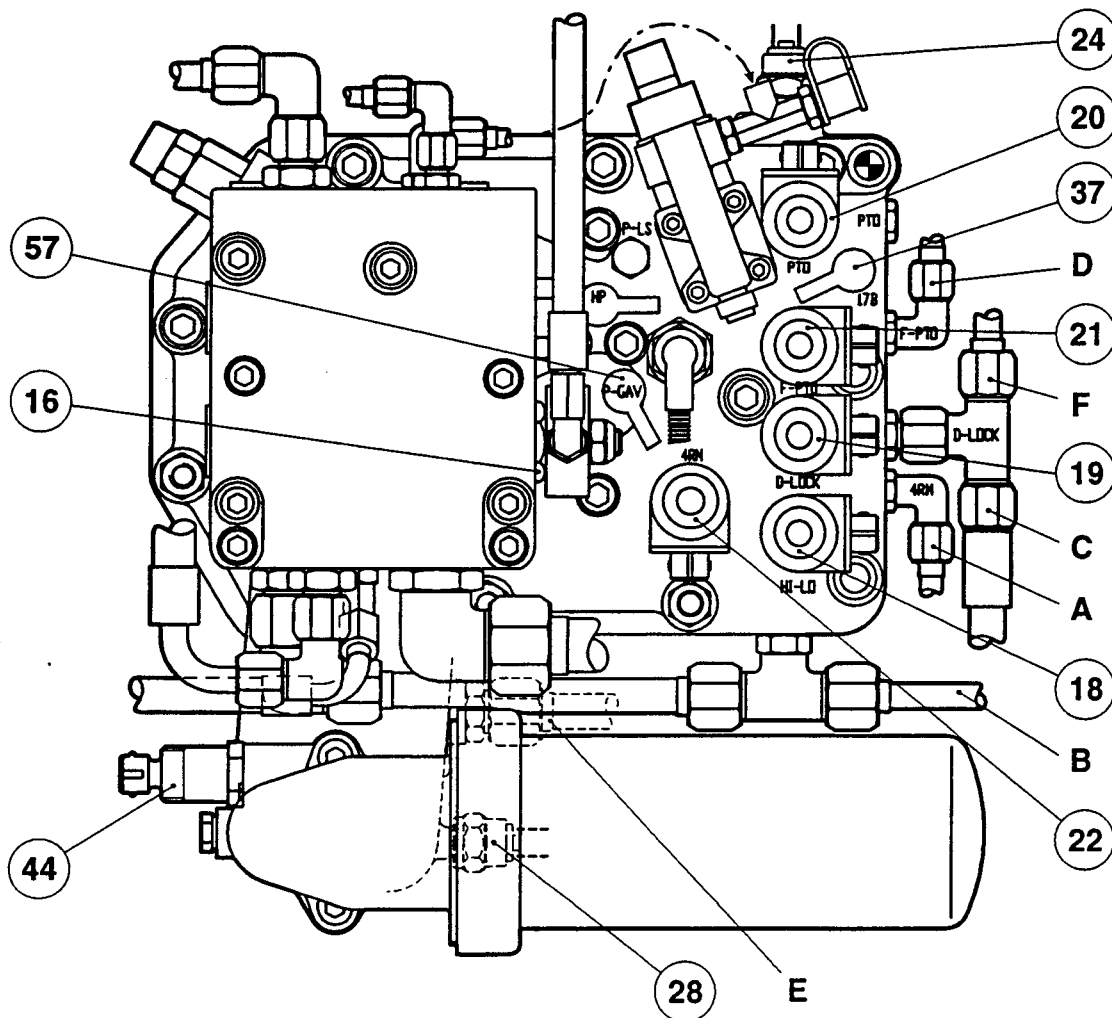



9 N01 *Trailer brake*

CONTENTS

- <b>General</b> _____	2
<b>A. Identification of ports</b> _____	2
<b>B. Operation of spools</b> _____	4
<b>C. Bleeding the trailer braking system</b> _____	4



9N01.2

## 6100 SERIES TRACTORS

**Hydraulics - Closed centre****General**

The design of the trailer braking system for 6100 series tractors is identical to that of 8100 series tractors.

The hydraulic unit mounted on the right-hand cover includes two override units installed in series.

The inner unit **(1)** (Fig. 1) ensures priority to the 17-bar circuits and the lift control valve mounted on the auxiliary spool valve assembly.

The outer unit **(2)** (Fig. 2) shares priority between the steering and trailer braking.

**A . Identification of ports (Figures 1 and 2)**

**Note:** As the hydraulic unit is fitted on the cover (54), high-pressure port "B" of the inner unit (Fig. 1) communicates directly with the output of the variable-displacement pump.

- A** : Supply to steering distribution valve (Orbitrol)
- C** : LS piloting to the pump controller
- D** : LS piloting from Orbitrol
- E** : To trailer brake connector
- F** : Pressure to lift control valve and auxiliary spool valves
- G** : LS piloting from lift control valve and auxiliary spool valves
- I** : 17-bar output linked to LP channel on right-hand cover
- J** : Plugs
- K** : Piloting from brake master cylinders

- O.st : Steering override spool
- LP : Low-pressure spool
- HP : High-pressure spool

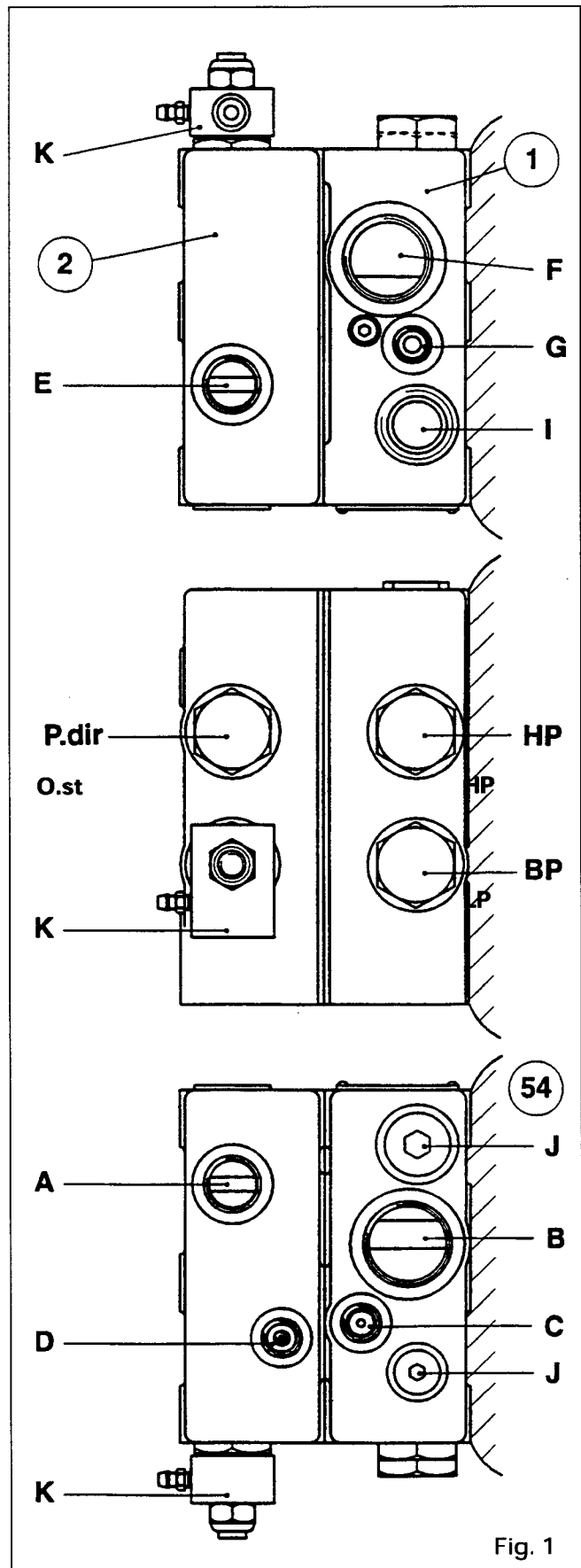

Fig. 1



**Hydraulics - Closed centre**

9N01.3

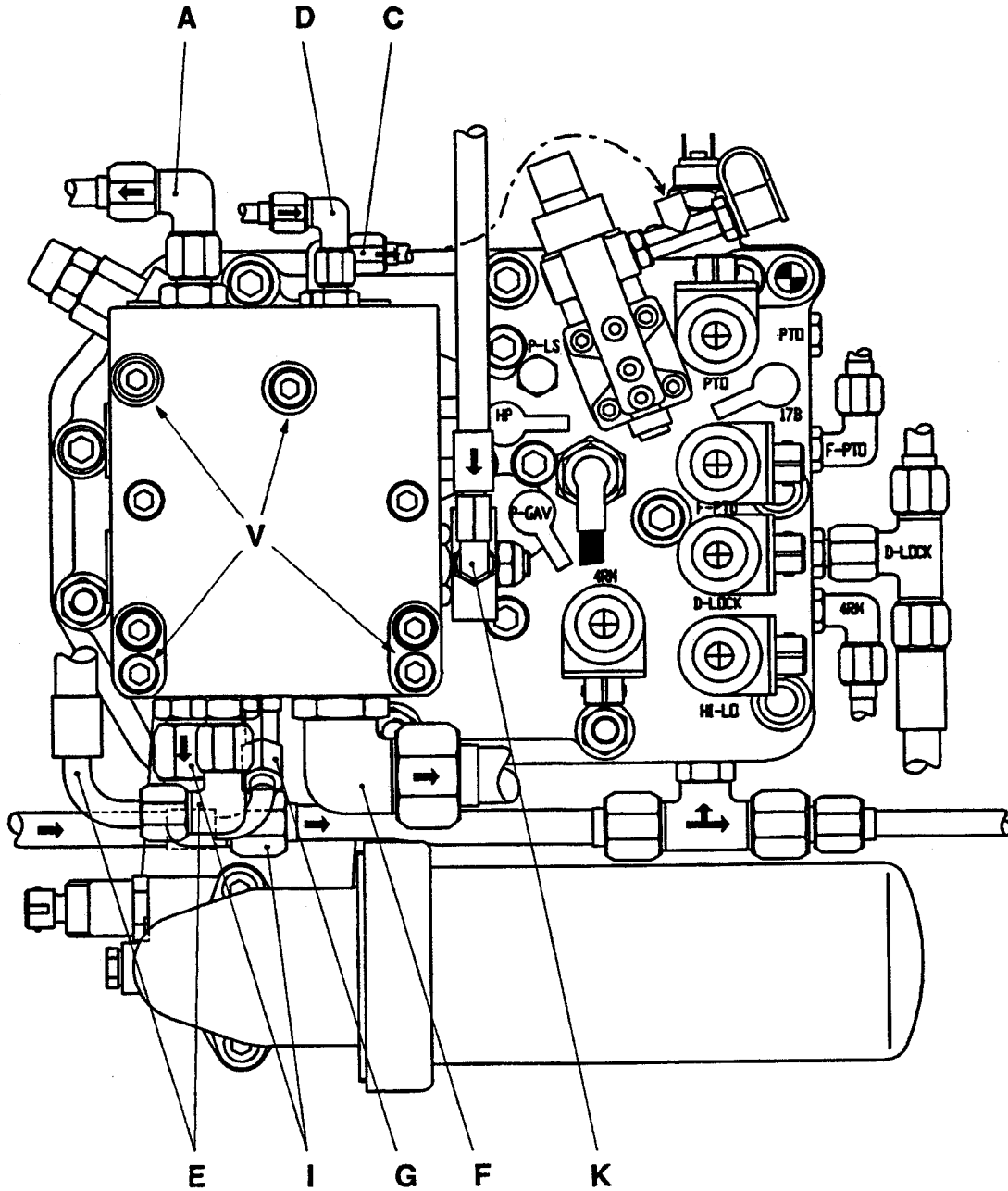

Fig. 2



9N01.4

---

 6100 SERIES TRACTORS
 

---



## Hydraulics - Closed centre

### B . Operation of spools

#### Steering override spool (4) (Fig. 3)

The spool moves to the left due to the effect of the spring (5). The flow from channel B is routed to the Orbitrol distributor valve as priority via channel A. With the steering in the neutral position, there is no flow in this channel. The increase in pressure forces the spool to move to the right, so compressing the spring (5) and allowing flow into channel J.

In operation a pilot pressure from the Orbitrol is established in channel D and this pushes the spool back to the left, so allowing flow to channel A required for the steering.

The remaining flow is routed to channel J.

#### Trailer brake spool (6) (Fig. 3)

When the trailer brake is not actuated, there is no pressure in channel K and the spool allows communication between channels L and R.

As soon as the tractor braking system is used, the pressure in channel K moves the piston (7) which pushes the spool (6) to the left, so allowing flow between channels J and L.

The pressure increase in channel L acts on the end of the spool (6) and compresses the spring (8), so re-establishing the balance allowing the pressure to be maintained in channel L according to the pressure in channel K.

This maintaining of pressure is obtained by establishing communication between channel L and either channel J or port R.

**Note : As in the case of the override unit (1) (see Section 9P01), there is 0.5 l flow from channel A to channel D (dynamic type steering) via a hole and a restrictor in the spool (4).**

### Tightening torque

Bolt V : 25 to 35 Nm, Loctite 542

### Special points

- Check for leaks from the seals and unions.
- Carry out hydraulic tests (see Section 9V01).

### C . Bleeding the trailer braking system

**Note : It is essential to bleed the main braking system before the trailer braking system.**

1. Run the engine at about 1,200 rpm. Correctly identify the return hose (1) located to the front left-hand side of the gearbox and block it with a clamp fitted with suitable protection (Fig. 4).
2. Fit a pipe on the bleed screw (1) as shown in Fig. 5.
3. Open the bleed screw and slowly press the coupled brake pedals Repeat this operation several times.
4. Close the bleed screw and remove the clamp from the return line.
5. Check the trailer brake pressure (see Section 9V01).
6. Carry out a road test.



**Hydraulics - Closed centre**

9N01.5

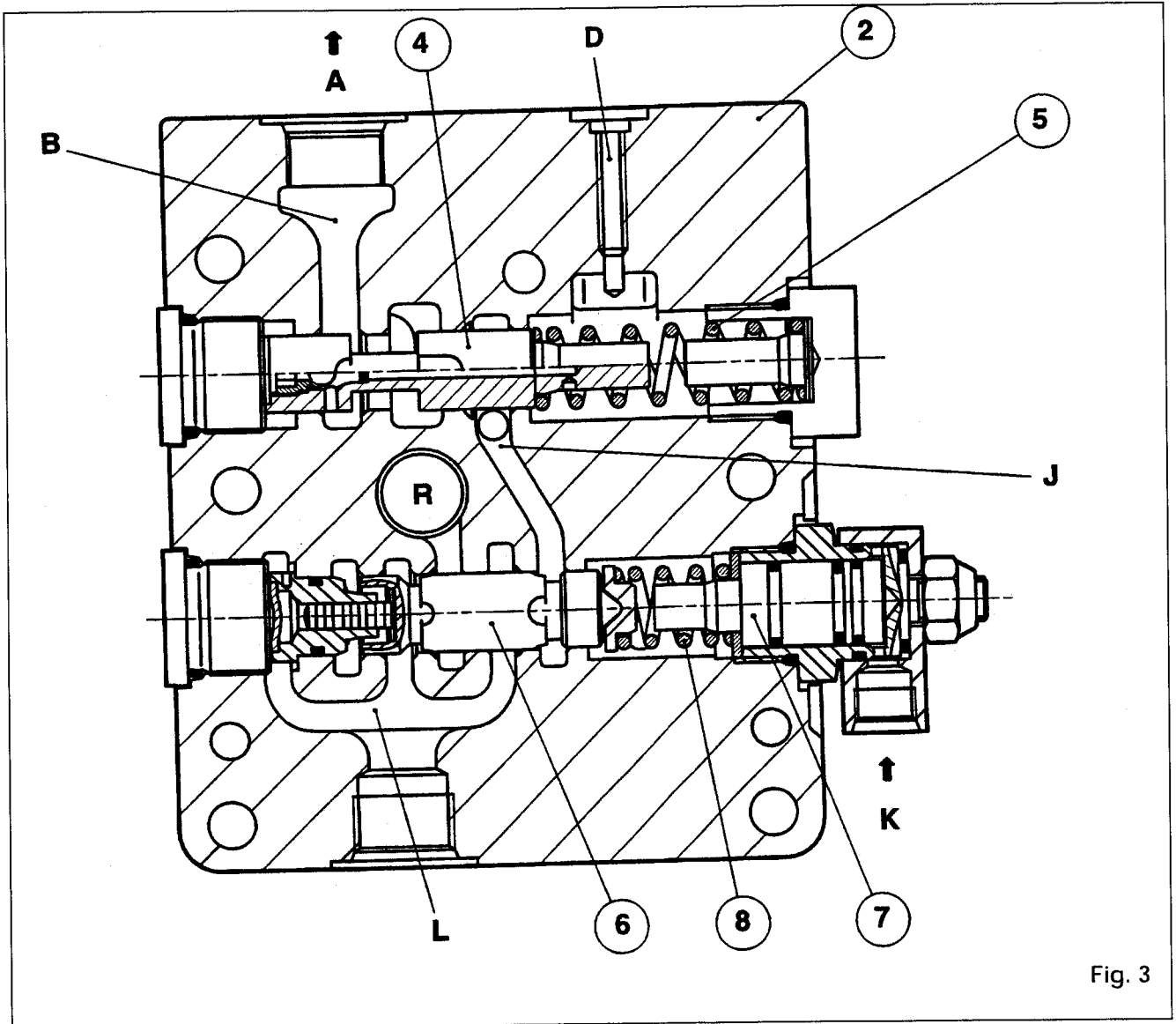

Fig. 3

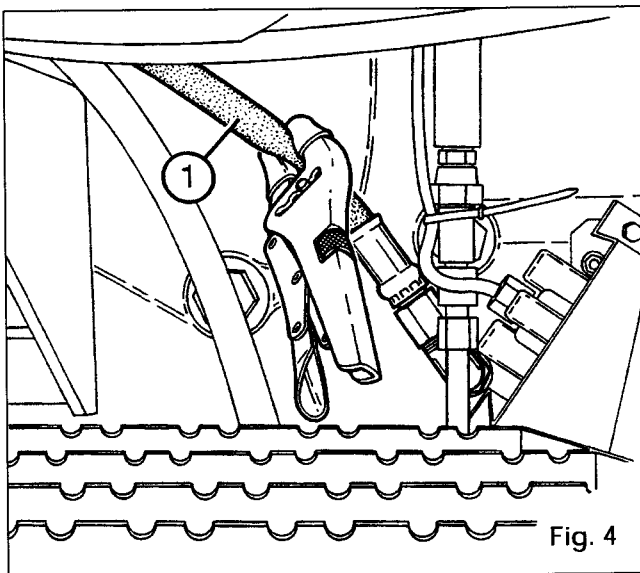

Fig. 4

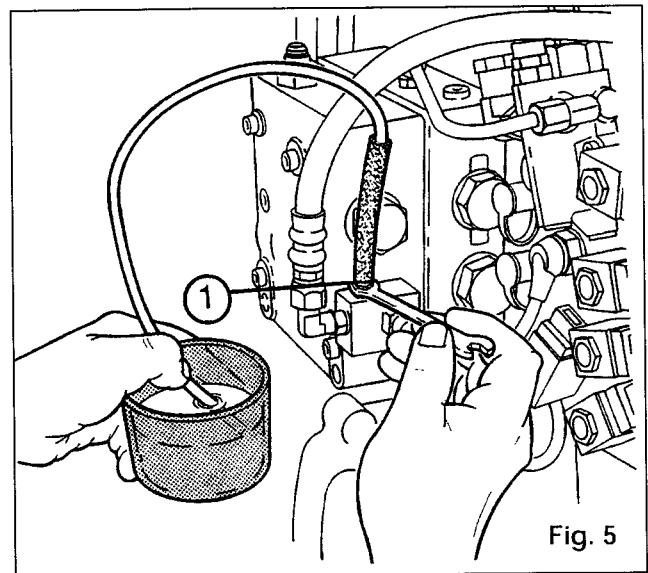

Fig. 5







9 P01 *Override unit*

CONTENTS

- <b>General</b> _____	2
<b>A. Identification of ports</b> _____	2
<b>B. Operation</b> _____	4



## Hydraulics - Closed centre

### General

The override unit (50) which includes two spools (Fig. 3) installed on the right-hand cover (54) receives flow from the variable displacement pump. It ensures that priority flows are provided to the steering circuit via the trailer brake unit (if fitted) and the low-pressure circuit (17 bars). The oil is then conveyed to the lift control valve and the auxiliary spool valves.

### Tightening torque (Fig. 2)

Bolts **V** : 25 to 35 Nm, Loctite 542.

### Special points

- Check for leaks from hydraulic unions O-rings between the override unit and the hydraulic cover.
- Carry out hydraulic tests (see Section 9V01) and check that the controls operate correctly.
- Carry out a road test.

### A . Identification of ports (Figures 1 and 2)

- A** : Supply to Orbitrol
- B** : HP supply from variable displacement pump (port drilled on the bearing face on the override unit and the cover (Fig. 2))
- C** : LS piloting to pump regulator
- D** : LS piloting from Orbitrol
- F** : Supply for lift control valve and auxiliary spool valves
- G** : LS piloting from lift control valve and auxiliary spool valves
- H** : Internal channel (Fig. 3)
- I** : 17-bar outlet

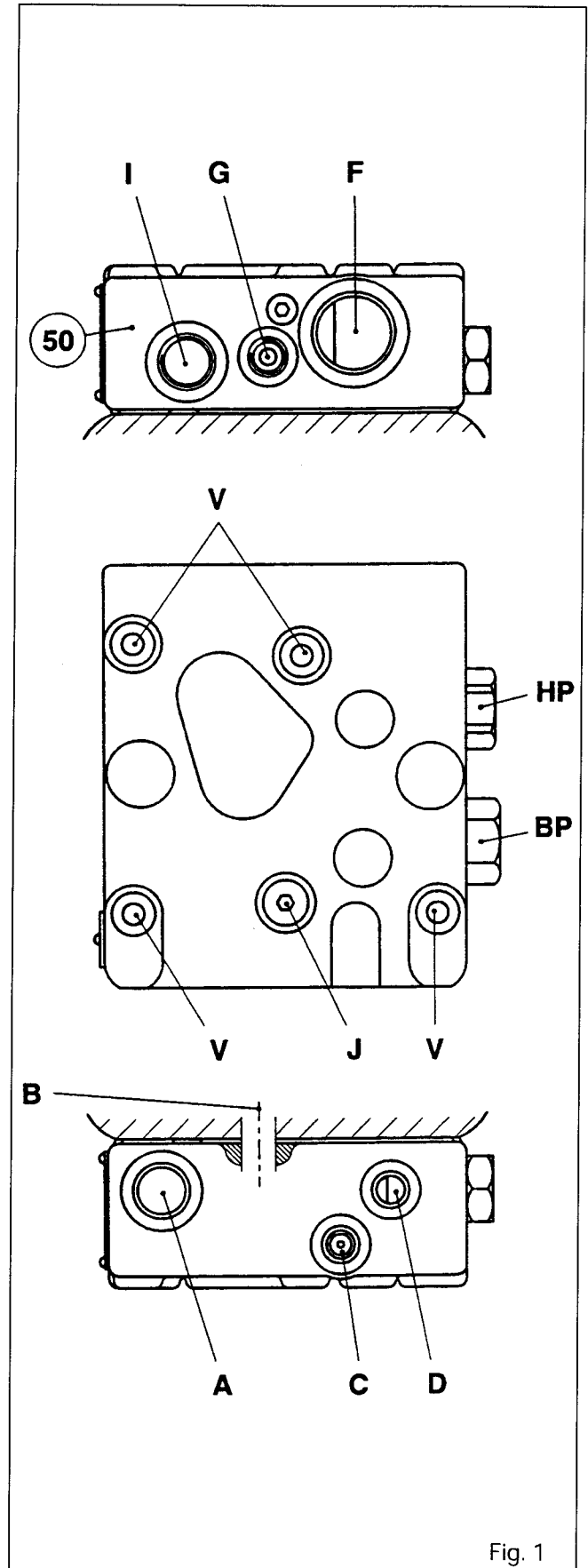

Fig. 1



6100 SERIES TRACTORS

Hydraulics - Closed centre



9P01.3

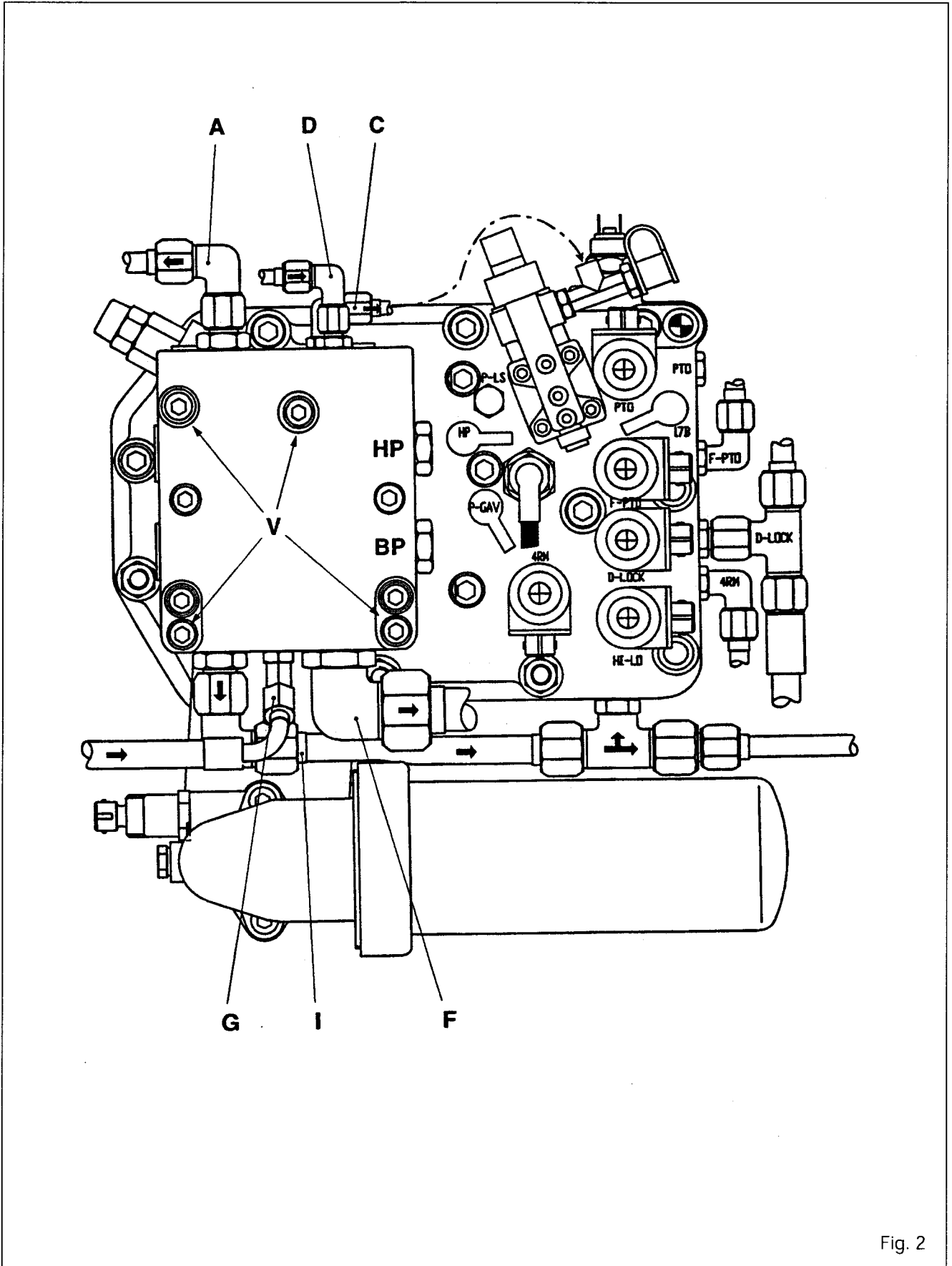

Fig. 2



9P01.4

---

 6100 SERIES TRACTORS
 

---

**Hydraulics - Closed centre**

---

**B . Operation (Fig. 3)**

---

1st priority : Steering (or 2nd unit if equipped with trailer braking)

Spool (2) moves to the left due to the action of spring (3).

The flow sent along channel **B** (Fig. 1) from the variable displacement pump is conveyed, as priority, to the Orbitrol distribution valve through channel **A**.

- **Steering in neutral** : The steering distribution valve (Orbitrol) is in the closed position. Pressure from the pump lifts spool (2) and the flow is directed to channel **H**.

- **Steering actuated** : A pilot pressure from the Orbitrol distribution valve arrives at port **D** and pushes spool (2) to the left, allowing flow through to port **A** supplying the Orbitrol unit.

**Note : A flowrate of approximately 0.5 l/mn passes from port A to port D via a hole and a restrictor in spool (2). This flow produces a pressure of approximately 6 bars at port D. The LS line carries that pressure to the pump regulator, set at 22 bars, to obtain a standby pressure of 28 bars.**

In the version equipped with trailer braking, ports **A** and **D** are closed with blanking plugs.

2nd priority : 17-bar pressure holding valve

Spool (4) is moved to the left due to the action of spring (5) allowing flow from channel **H** to reach port **I** (17-bar low pressure). As soon as the pressure at this port reaches 17 bars, the spool is in equilibrium allowing low pressure to be maintained and permitting flow to port **F** (auxiliary and lift).

When the auxiliary spool valves and lift control valve are used, an LS pilot pressure is sent to the unit via port **G** to join the LS line at port **C**.

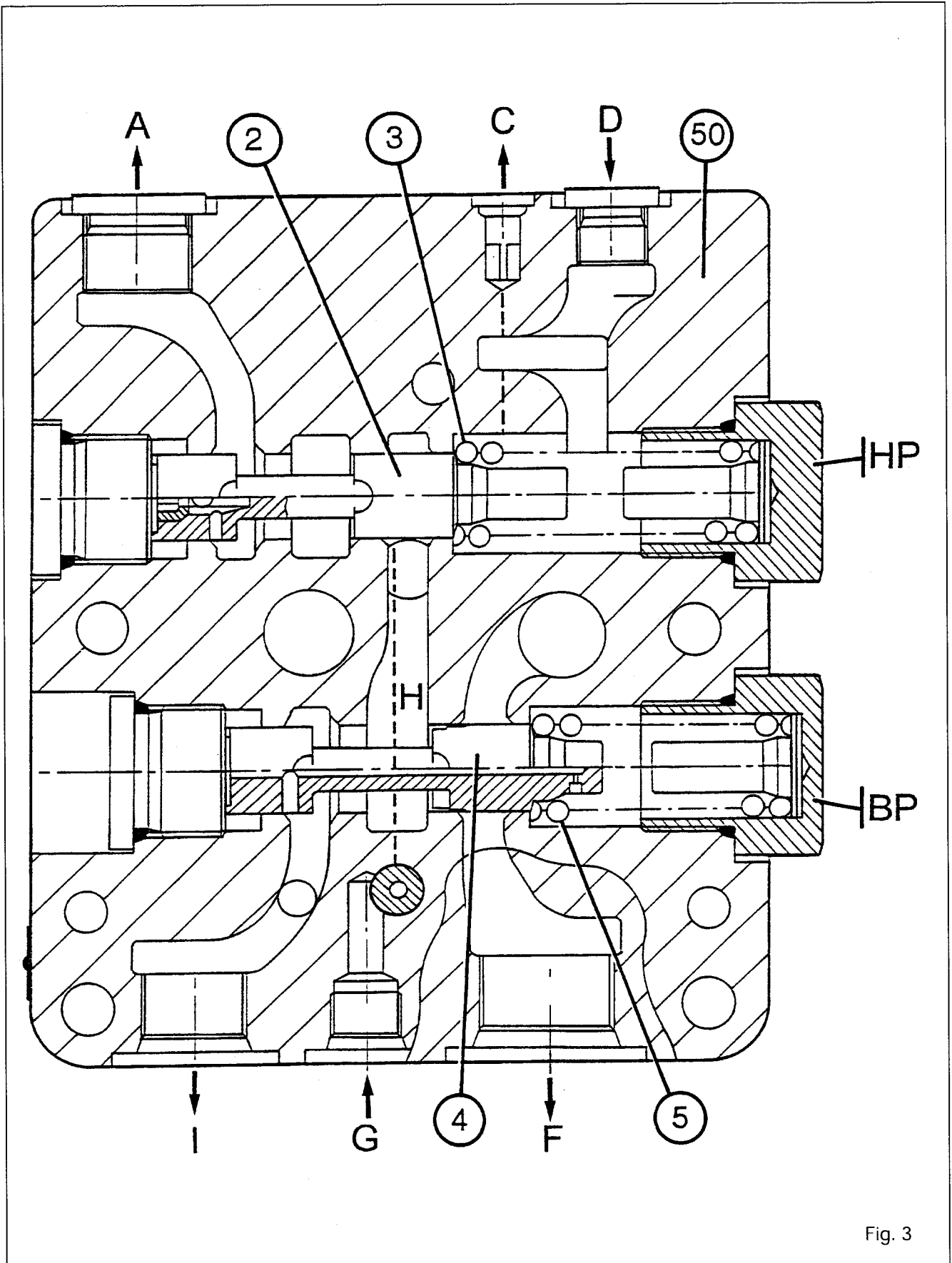

Fig. 3





9 Q01 *Auxiliary spool valves*

CONTENTS

-	<b>General - Operation</b> _____	<b>2</b>
A.	<b>Removing and refitting the spool valves unit</b> _____	<b>6</b>
B.	<b>Assembly procedure</b> _____	<b>7</b>
C.	<b>Fitting and adjusting the control cables</b> _____	<b>8</b>





9Q01.2

## 6100 SERIES TRACTORS



### Hydraulics - Closed centre

#### General

The proportional auxiliary spool valves, type SB23 Bosch, are installed on the high-flow, high-pressure system. They are supplied with hydraulic fluid from the override units.

If no function is engaged, all the flow is directed to the spool valves. If some priorities are supplied with fluid, the remaining flow is then available for the auxiliary spool valves.

Each spool valve is equipped with a flow regulating system controlled by a black, red or green button located on a console above the spool valves unit.

The valve's main spool is actuated by a cable connected to a lever located in the cab. The spool routes the fluid to one of the outlet ports. Each outlet port is linked to the LS pilot line of the variable-displacement pump controller via the override units.

#### Various types of spool valves

- a - 3 positions - Return to neutral by spring, zero leak
- b - 4 positions - Automatic return to neutral (kick-out)
- c - 4 positions - Automatic return to neutral (kick-out), zero leak
- d - 4 positions - Special for hydraulic motor

#### Proposed assemblies

- GP050 = a + b
- GP052 = a + b + c
- GP054 = c + c + c

#### Couplers

The couplers are of the Parker 7451 type: coupling / uncoupling by pressure on one side. These couplers are identical to those fitted on the open centre type hydraulic centre.

#### Operation (Fig. 1)

When the spool **(1)** is pulled, the fluid enters via channel **P**, passes through restrictor **C** and port **D**. It is then routed to channel **E**, pushes rod **(2)** and enters chamber **F**. At the same time, the ramp of the spool valve raises the plug **A** and the oil flows via port **B**.

Supply to port **A** is obtained by pushing the spool **(1)**. The flowrate is regulated by means of the button **(4)** and the controlling spool valve **(5)**.



Hydraulics - Closed centre

9Q01.3

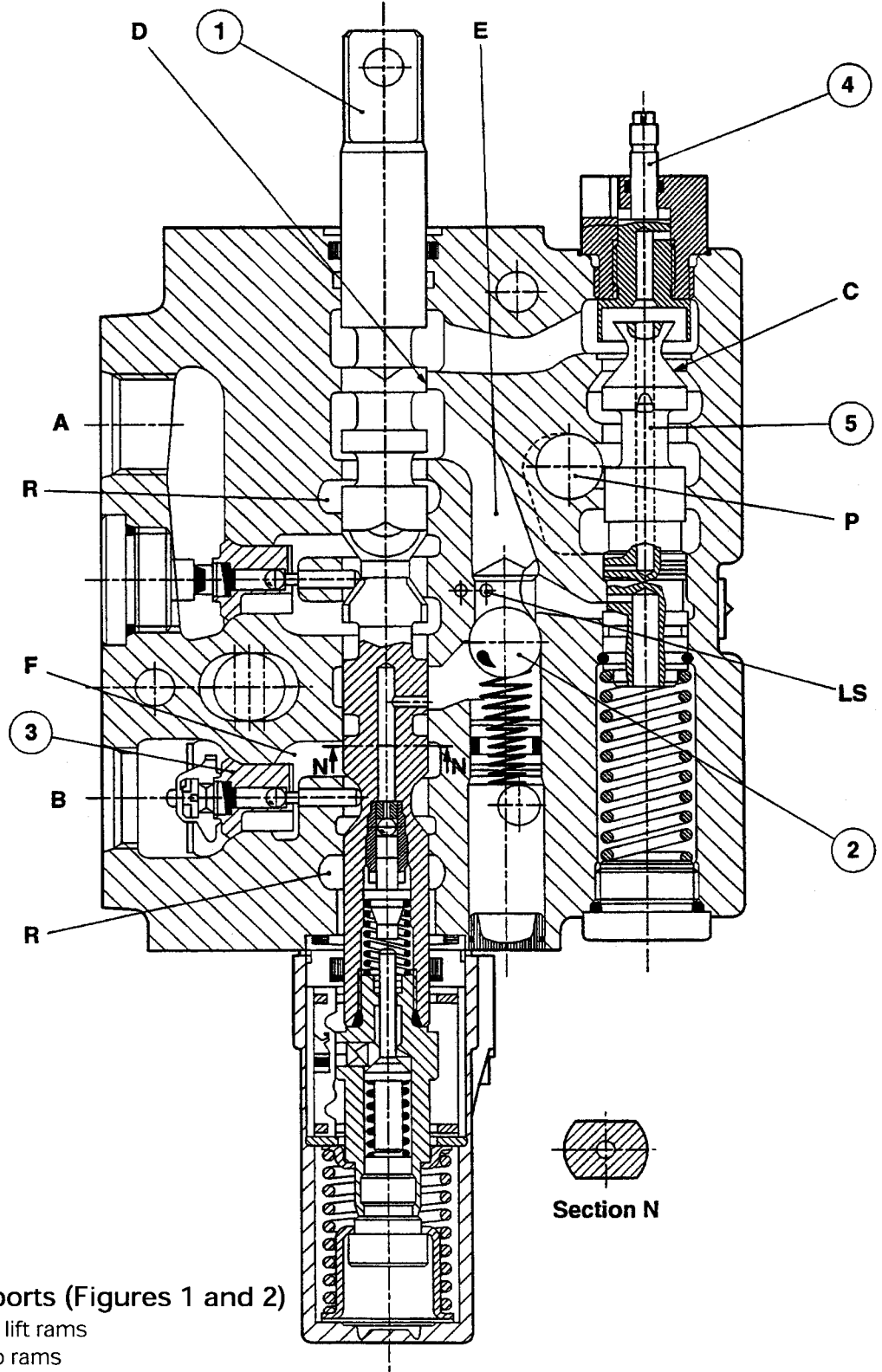

Identification of ports (Figures 1 and 2)

- (15)** Return from lift rams
- (16)** HP supply to rams
- A and B** Couplers
- P** Pressure
- R** Return from auxiliary spool valves
- LS** Signal to variable-displacement pump controller

Fig. 1



9Q01.4

# Hydraulics - Closed centre

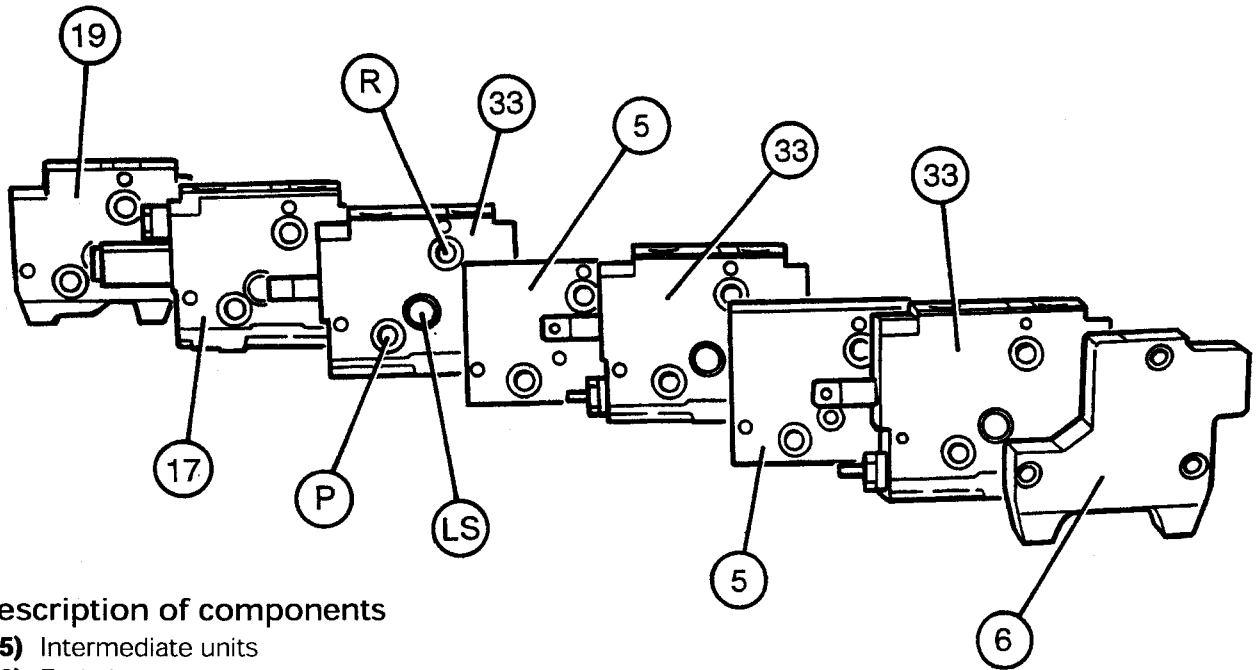
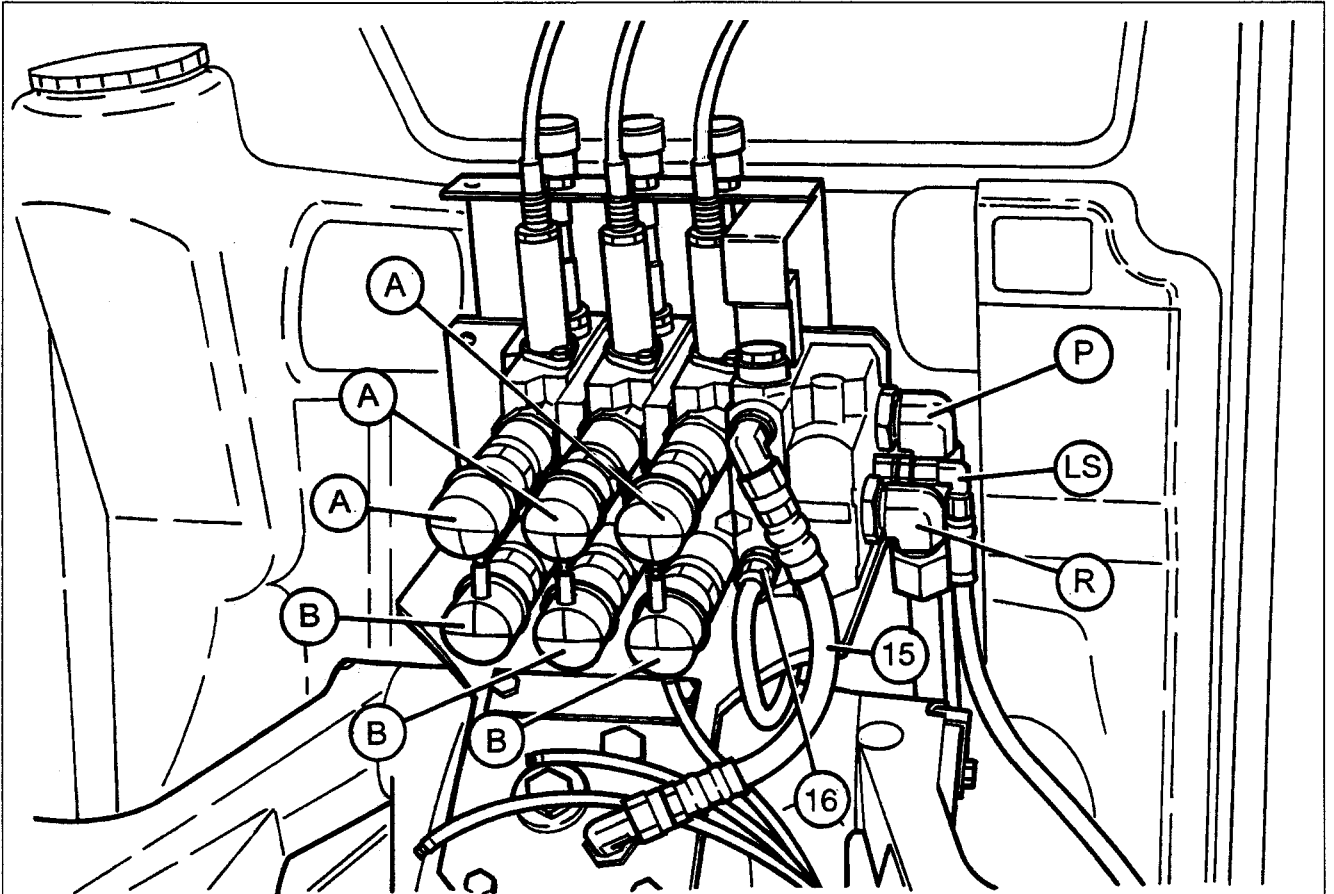

### Description of components

- (5) Intermediate units
- (6) End plate
- (17) Lift control valve
- (19) Inlet unit
- (33) Auxiliary spool valves

Fig. 2



**Hydraulics - Closed centre**

9Q01.5

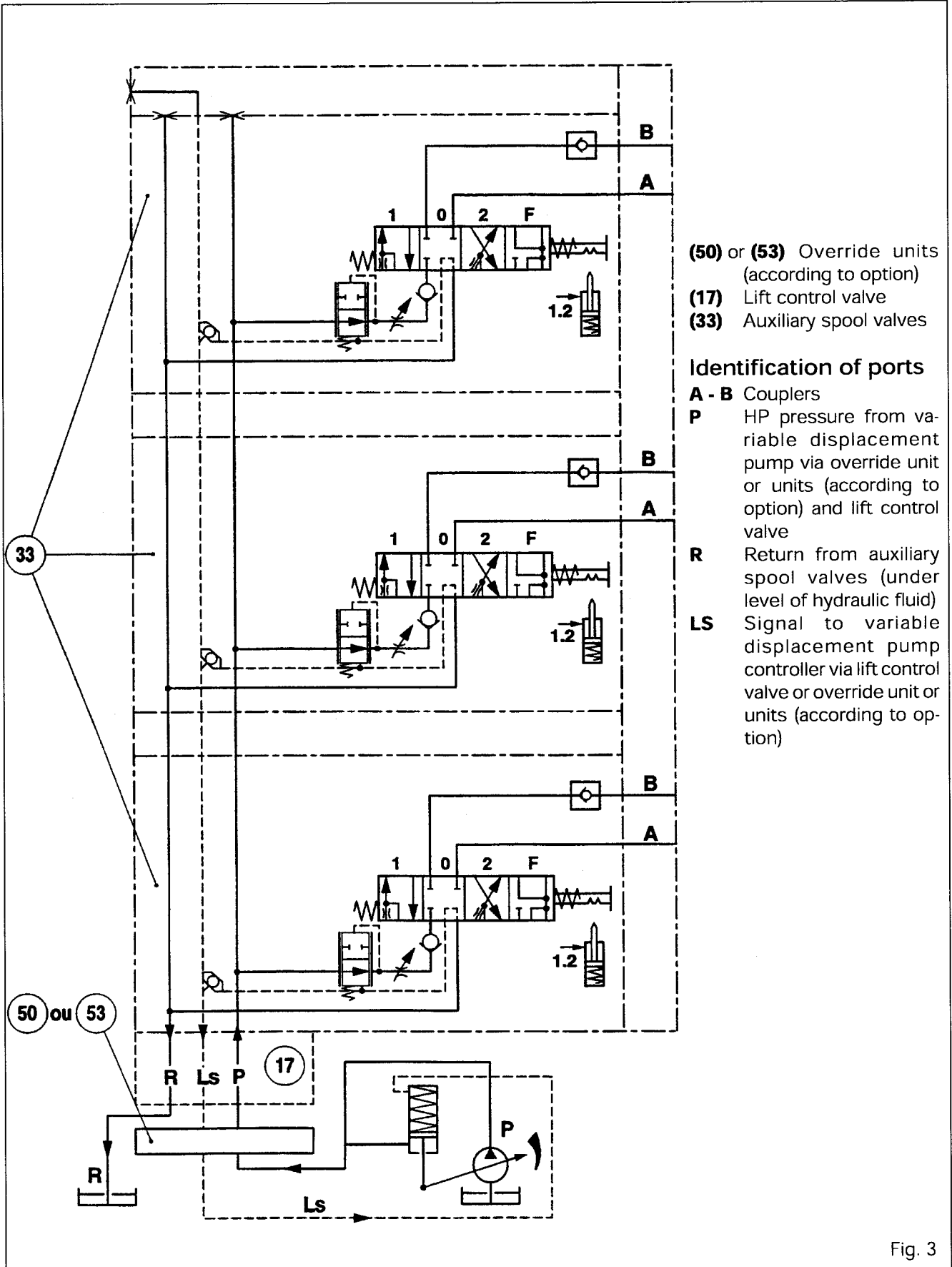

Fig. 3



9Q01.6

## Hydraulics - Closed centre

### A . Removing and refitting the spool valves unit (Figures 4 and 5)

#### Removal

1. On each auxiliary spool valves, disconnect the control cables (2) and the valve adjusting rods (9) (flow control).
2. Disconnect the tubes (8), (16) and (30) and hoses (15) and (31).
3. Mark and disconnect the wiring harnesses from the raising and lowering solenoid valves, (14) and (18) respectively.
4. Remove the bolts (10). Detach and remove the support and spool valves assembly.
5. Remove the bolts (11). Separate the spool valves unit from the support.

#### Refitting

6. Carry out the same operations as for removal in the reverse order.
7. Fit and adjust the control cables on the spool valves (see § C).
8. Check the correct operation of the spool valves in each position and the adjustment of the flow control (see hydraulic tests, section 9V01).

#### Special points (Fig. 5)

- . Fit the knurled knob (12), observing a space "E" between the nut and the grommet.
- . Smear the support mating face on the lift cover with Loctite 510 or equivalent.

#### Tightening torques (Figures 4 and 5)

- . Bolt (10) : 50 to 70 Nm (threads coated with Loctite 510)
- . Bolt (11) : 25 to 35 Nm
- . Bolt (13) : 0.5 to 1 Nm
- . Flow control valve "V" : 64.8 to 69.2 Nm
- . Shock valve "C" : 64 to 66 Nm

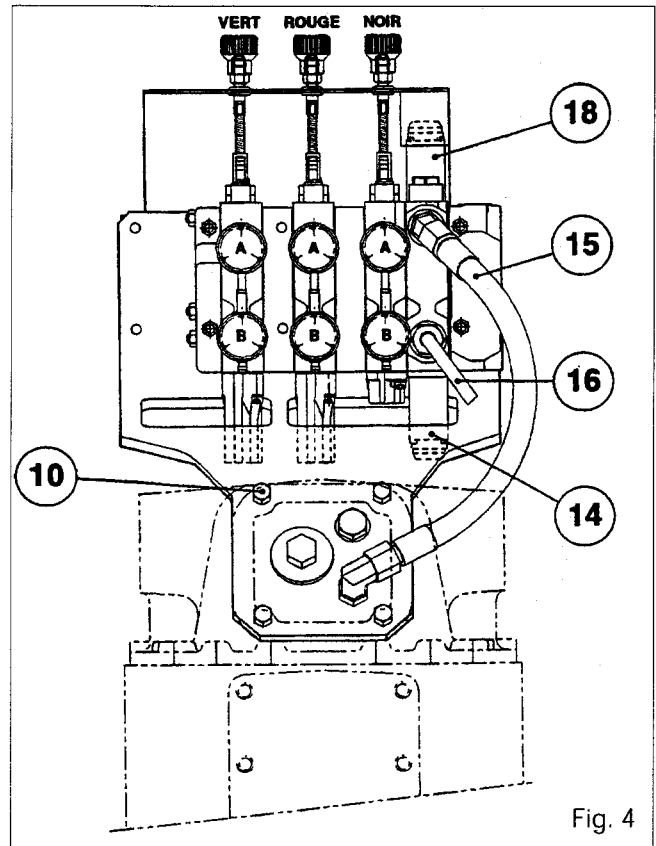

Fig. 4

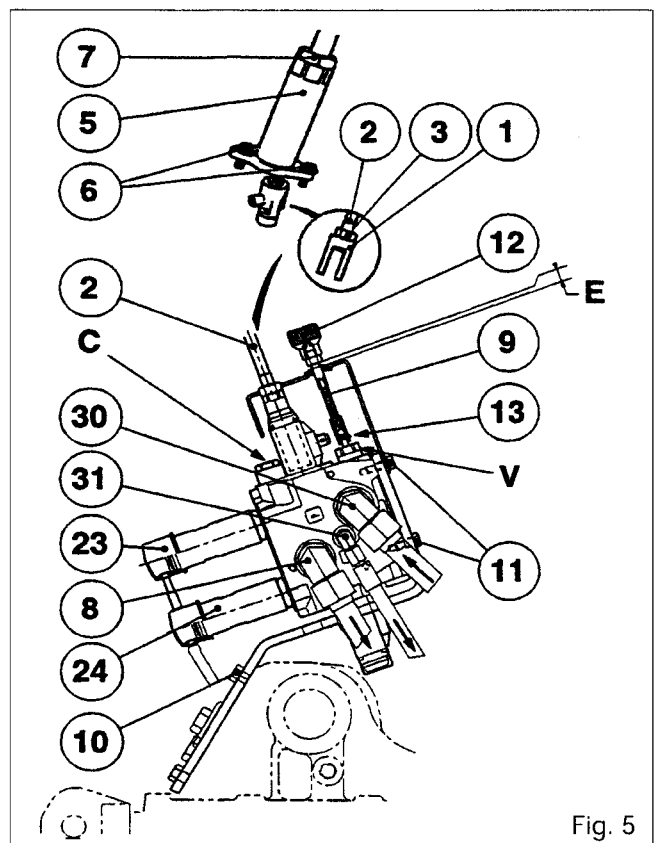

Fig. 5



## Hydraulics - Closed centre

9Q01.7

### B . Assembly procedure (Figures 6 and 7)

To obtain correct fitting of the O-rings (3) to (5) and the thickness shims (7), each spool valve including the lift control valve must be reinstalled vertically as shown in Fig. 6.

**Important :** The thickness shims (7) allow the tightening load to be distributed on the three studs and not on all the spool valve contact faces. To avoid seizing of the spools, it is mandatory to comply with the correct fitting of shims and the specified tightening torque on nuts (8).

Screw the nuts until contact with the locking plate (6).

Place the spool valves assembly with the faces "F" bearing on a flat surface in order to ensure correct positioning.

Tighten the nuts to between 30 and 33 Nm (Fig. 7). Fit the unions and couplers.

9. Check the operation of the spool valves in each position and the adjustment of the flow control (see hydraulic tests, Section 9V01).

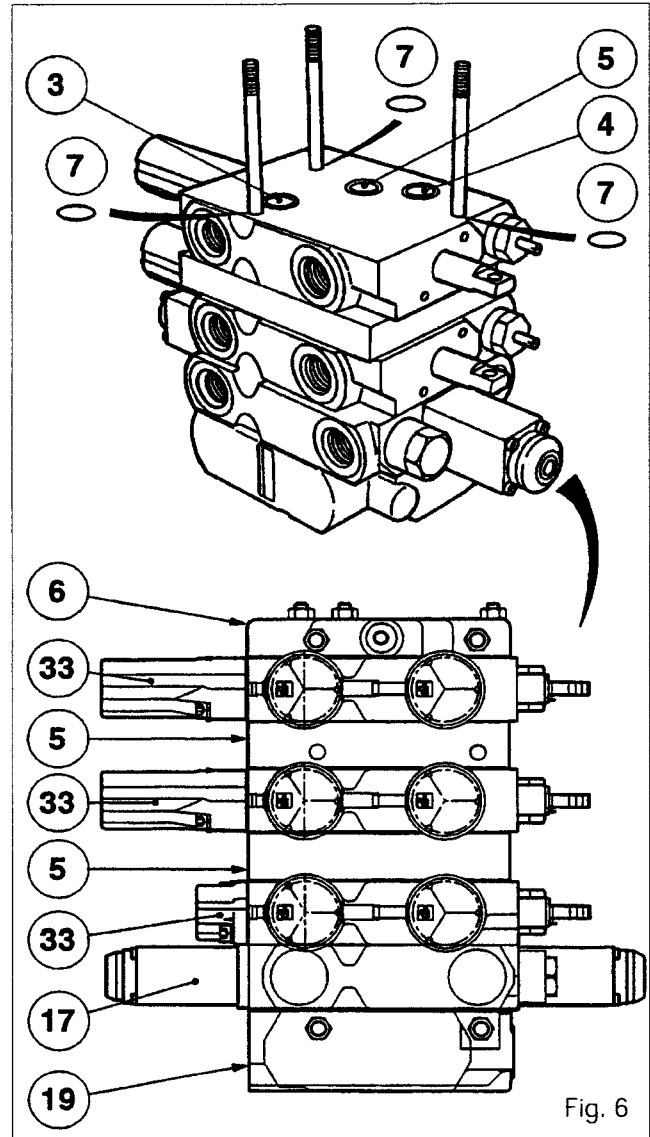

Fig. 6

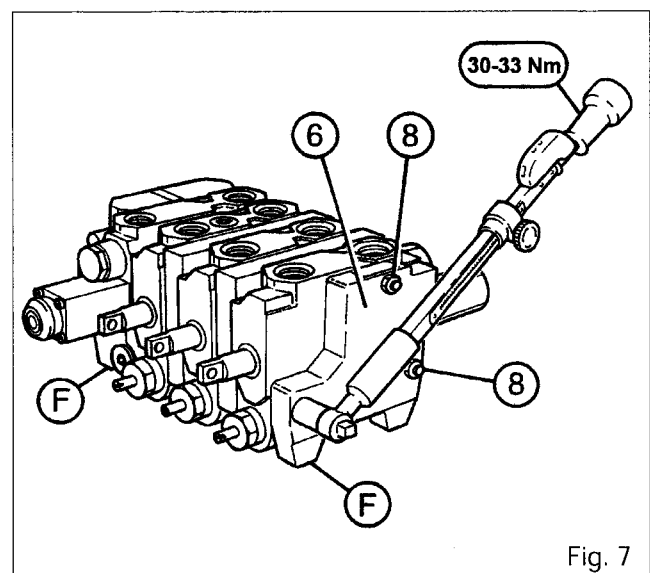

Fig. 7



9Q01.8

## 6100 SERIES TRACTORS

**Hydraulics - Closed centre****C . Fitting and adjusting the control cables (Fig. 8)****Special points**

The pins (5) are to be fitted after coating them with Loctite 241 or equivalent.

The order of fitting of the levers to the spool valves is indicated by the numbers 1 to 3.

Lever 4 is used for the fitting of a fourth spool valve, where required.

The friction washers (10) are to be coated with Molybdenum bisulphide before being fitted.

The nuts (8) are to be tightened so as to place the friction washers (10) under slight stress.

**On support and lever**

**Note :** The clevis (1) can be fitted on link rod A or B depending on the type of spool valve.

**Fitting A : Standard spool valves**

**Fitting B : Spool valves with floating position**

10. Insert the cable into the attachment point (6).

**Note :** When the attachment (6) is offset (with the spool valves in the floating position), fit the spacer (1) and the plate (2) as shown in Fig. 9.

11. Screw the clevis (1) level with the threaded section of the cable (2) and fit the link rod A or B of the lever L concerned. Position the clip (7).

Tighten the nut (3), checking that the cable is not constrained.

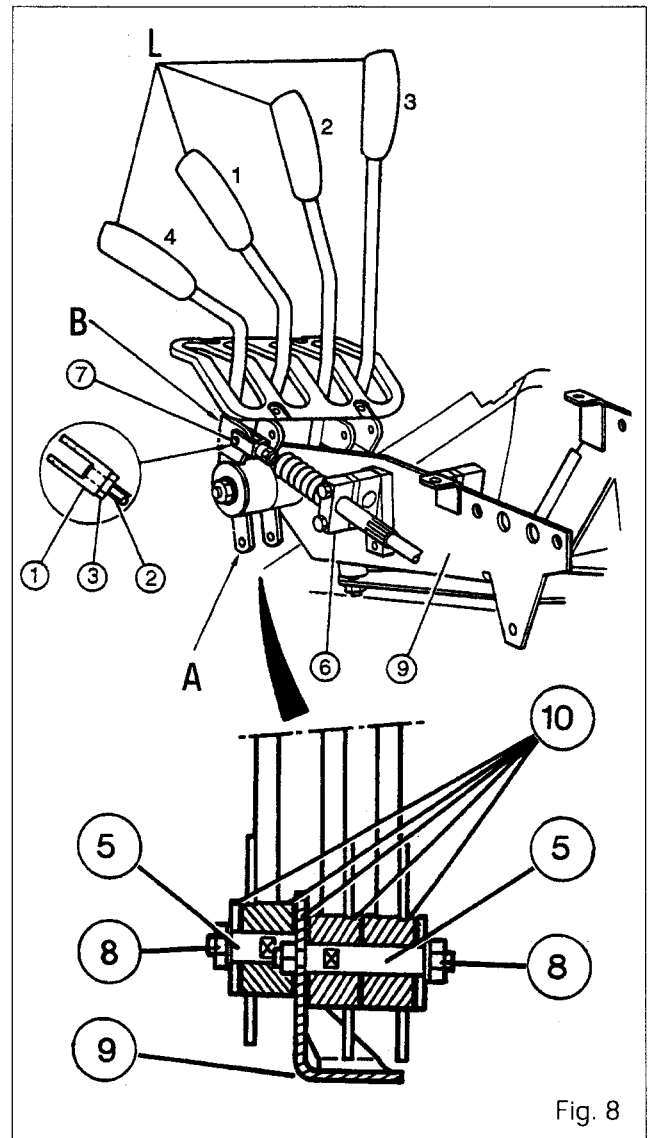

Fig. 8

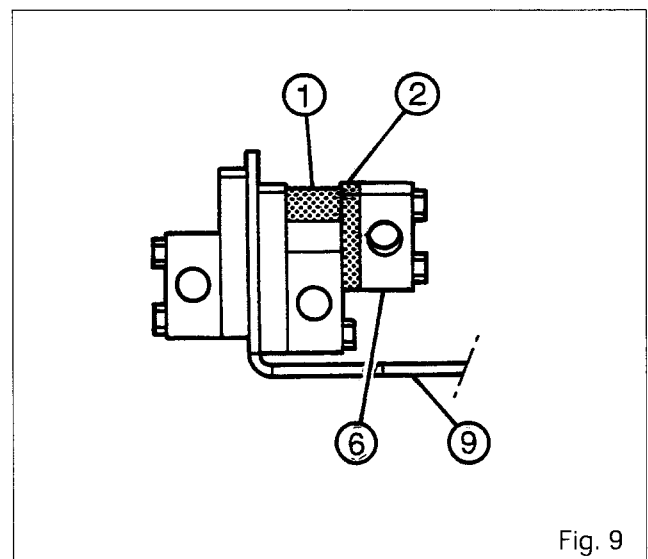

Fig. 9



## Hydraulics - Closed centre

9Q01.9

### On spool valves (Fig. 9)

12. Check that the spools of the valves are in the neutral position.
13. Screw clevis **(1)** level with the threaded section of cable **(2)**. Tighten the nut **(3)** and fit the pin **(4)**.
14. Partially screw on the housing **(5)** and fit the bolts **(6)** without tightening them.
15. Adjust the housing so that the control lever is correctly positioned with respect to the plate **(4)** (Fig. 8).
16. Lock the bolts **(6)** and tighten the nut **(7)** to a torque of 20 Nm.
17. Check that the valve controls operate correctly in all three or four positions, according to the type fitted.

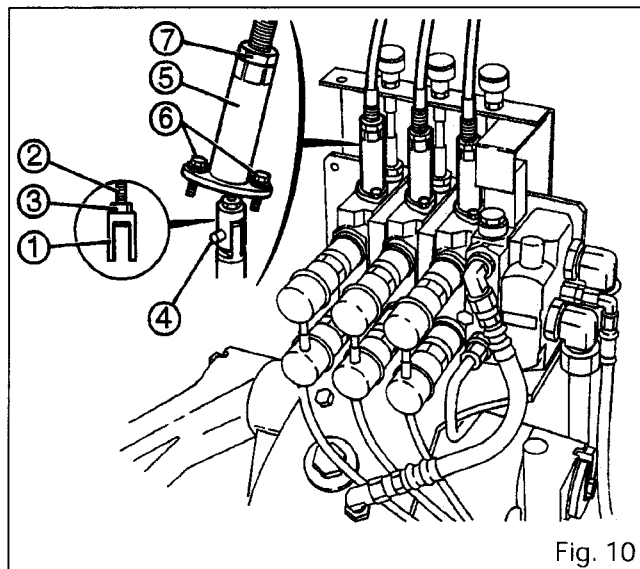

Fig. 10





**Hydraulics - Closed centre****9 R01    Lift control valve**

## CONTENTS

- <b>General</b> _____	<b>2</b>
<b>A. Removing and refitting the lift control valve unit</b> _____	<b>2</b>
<b>B. Description</b> _____	<b>2</b>
<b>C. Neutral position</b> _____	<b>4</b>
<b>D. Lifting position</b> _____	<b>5</b>
<b>E. Lowering position</b> _____	<b>6</b>
<b>F. Assembly procedure</b> _____	<b>6</b>



9R01.2

## 6100 SERIES TRACTORS

**Hydraulics - Closed centre****General**

The lift control valve (17) is different from the lift control valve used with the hydraulic system of the open centre type. Located between the inlet unit (19) and the auxiliary spool valves assembly, it is attached to a support mounted to the rear of the lift cover (Fig. 1). Its function is to regulate the flow of hydraulic fluid to and from the lift rams according to the signals transmitted to it by the computer of the electronic lifting system.

The lift control valve is equipped with an **LS** pilot port for the load sensing system.

This pilot port allows the lift control valve to send pressure data to the variable-displacement pump controller via the override unit.

**Description (Figures 2 to 6)**

The BOSCH lift control valve is made up of two sections :

**Hydraulic section (lift control valve)**

- (1) Non-return valve keeping the hydraulic fluid in the rams
- (2) Spool assembly used during the lowering phase
- (4) Control spool
- (5) Flow regulating spool
- (6) Shock valve
- (9) Flow regulating spool spring
- (10) Control spool spring
- (11) Spool assembly spring

**Electrical section (solenoid valves) (Fig. 1)**

- (14) Lifting solenoid valve
- (18) Lowering solenoid valve

**Designation of ports****On inlet unit (19) (Fig. 1)**

- (30) HP supply from the variable-displacement pump via the override unit or units (according to option)
- (31) LS signal to the variable-displacement pump controller via the override unit or units

**On lift control valve (17) (Fig. 1)**

- (15) Return hose to housing
- (18) Lowering solenoid valve

**Note : To distinguish between a hydraulic fault and an electrical fault, simply operate the push-buttons at the ends of the solenoid valves in order to deactivate the electronic lifting system.**

**A . Removing and refitting the lift control valve unit**

For the removal and refitting of the lift control valve unit, see Section 9Q01 §B.

**B . Description (Figures 2 and 3)**

- (17) Lift control valve
- (33) To auxiliary spool valves
- (50) or (53) Override units (according to option)

**Designation of ports (Figures 3 to 6)**

- P** : High pressure from the variable-displacement pump via the override unit or units (according to option)
- R** : Return from auxiliary spool valves (under level of hydraulic fluid)
- V** : Lift rams
- LS** : Signal to the variable-displacement pump controller via the override unit or units (according to option)

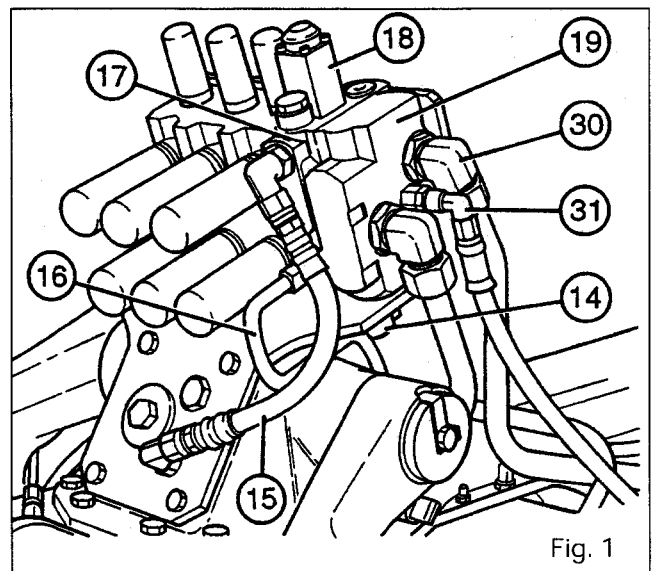

Fig. 1



6100 SERIES TRACTORS



Hydraulics - Closed centre

9R01.3

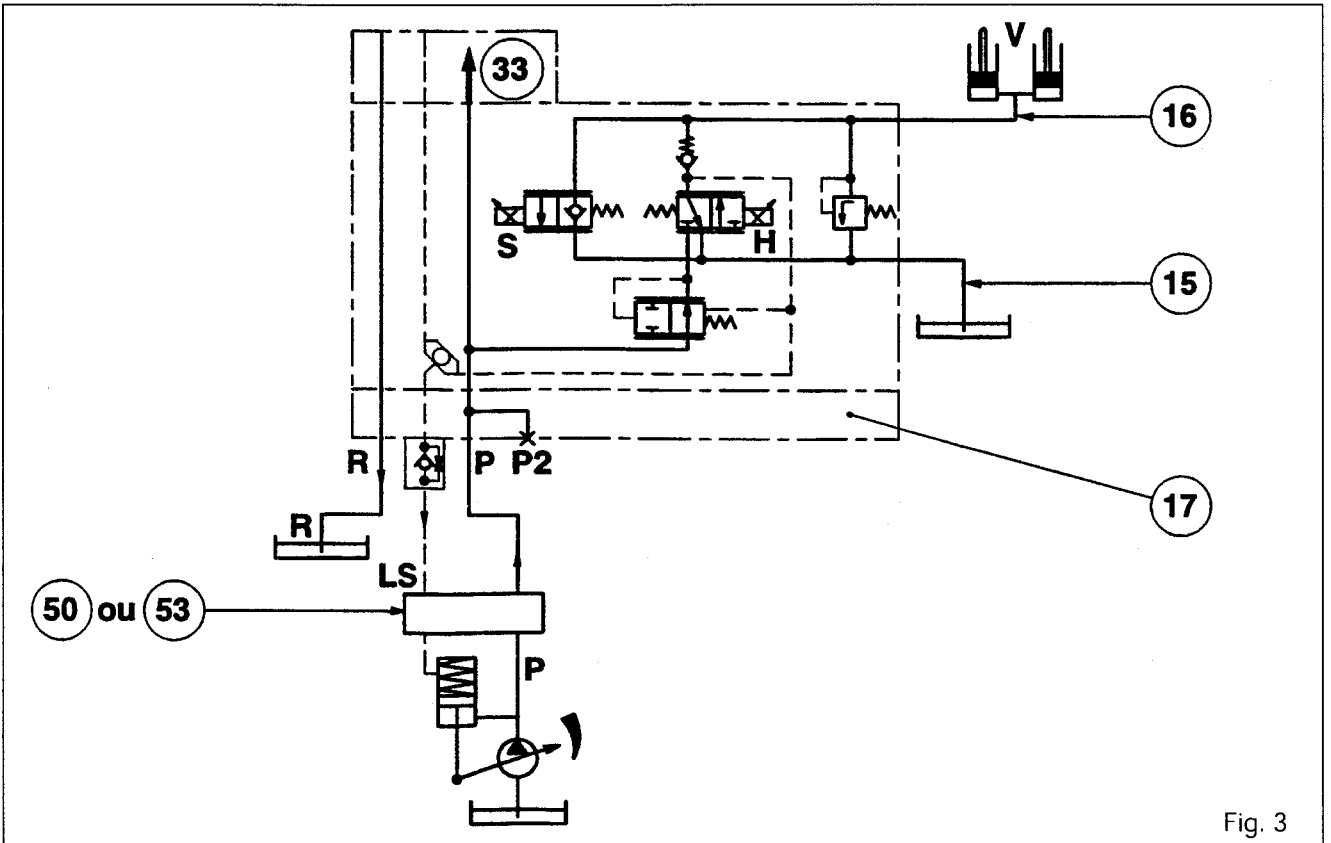
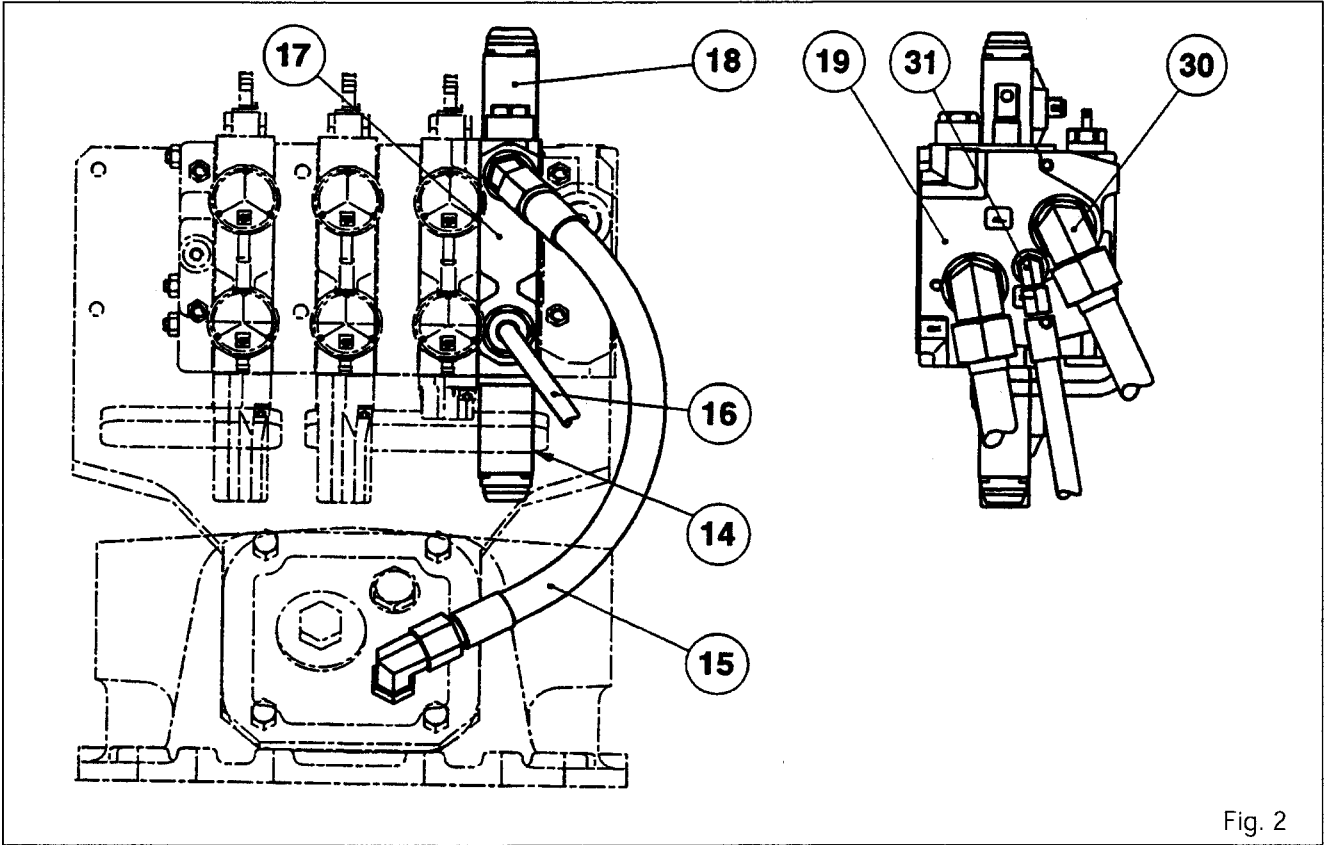



9R01.4

# 6100 SERIES TRACTORS



## Hydraulics - Closed centre

### C . Neutral position

When the engine is stopped and the lift control valve is in the neutral position, the control spool (4) and the spool assembly (2) are held in position by springs (10) and (11), respectively.

The flow regulating spool (5) is pushed downwards by spring (9).

When the engine is running and the lift control valve is in the rest position, no pressure data is sent to the variable-displacement pump. The LS line is connected to the return channel.

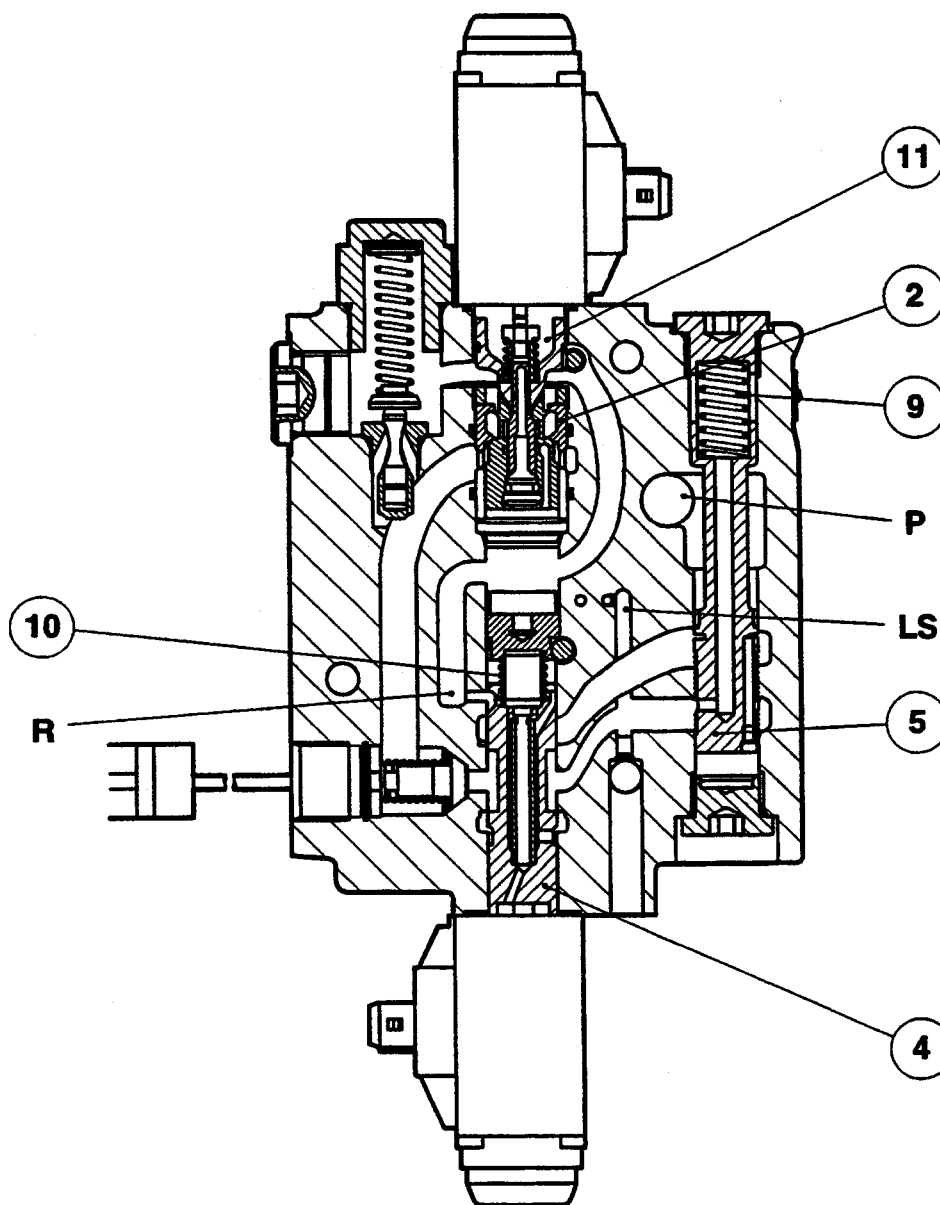

Fig. 4



## Hydraulics - Closed centre

9R01.5

### D . Lifting position

When the lifting solenoid valve **(8)** is actuated, the control spool **(2)** moves upwards.

The **LS** pressure data is transmitted onto the upper face of the flow regulating spool **(5)** (same side as spring **(9)**) and moves the spool downwards, so directing the flow to the control spool and the non-return valve **(1)**.

The movement of the flow regulating spool is damped by the volume of hydraulic fluid contained in chamber "d".

As soon as the pressure on the non-return valve **(1)** exceeds the pressure in the rams, the lift arms are raised.

The **LS** line is connected with the outlet **(16)** and data is transmitted to the variable-displacement pump controller.

If the pressure on the rams is too great (impacts on lift arms), valve **(6)** opens and the excess pressure is directed to the housing.

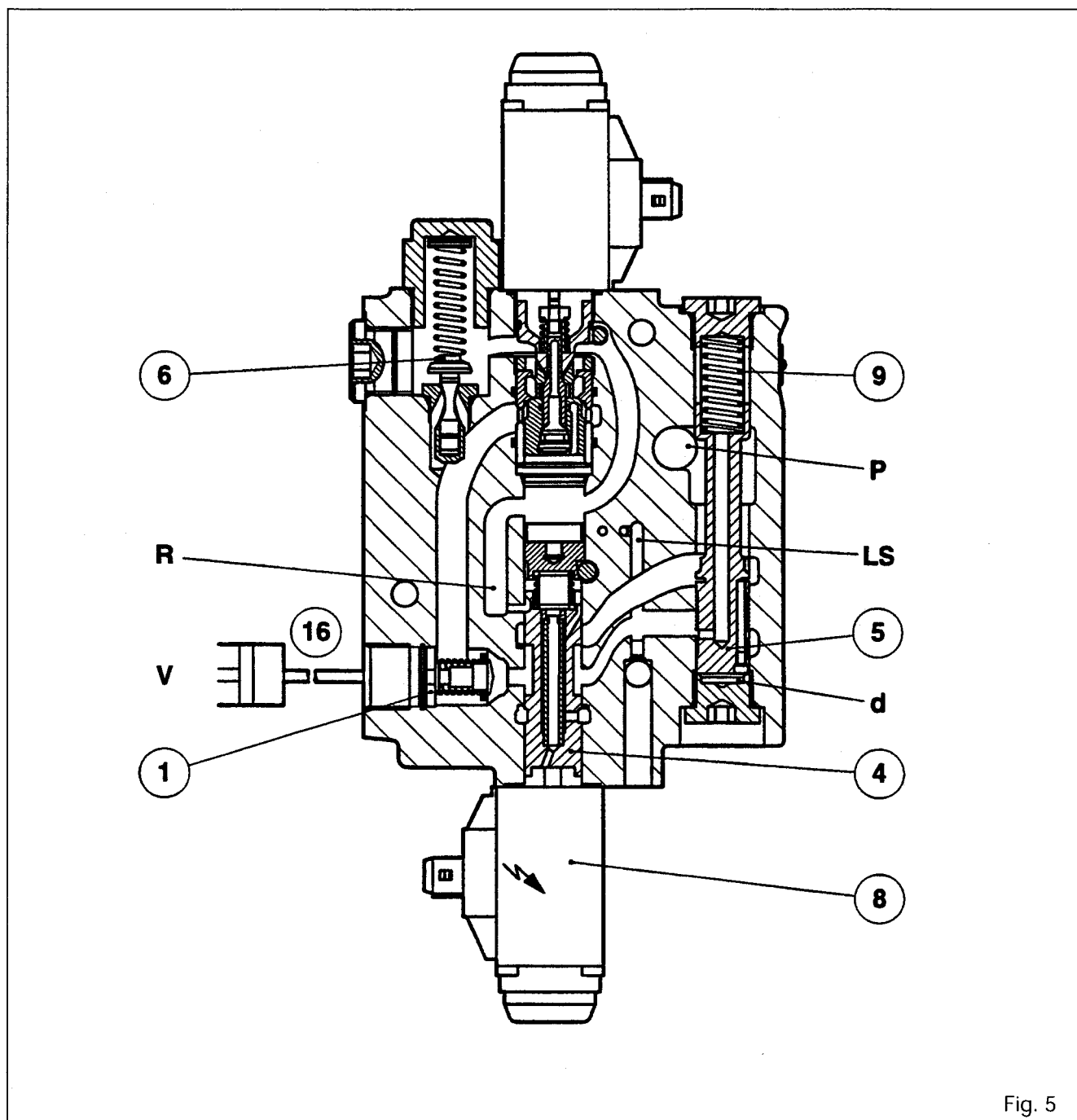

Fig. 5



9R01.6

# 6100 SERIES TRACTORS



## Hydraulics - Closed centre

### E . Lowering position

When the lowering solenoid valve (7) is actuated to lower the lift arms, spool assembly (4) allows the flow from the rams to go to the return channel. The LS pressure data is transmitted onto the face of the flow regulating spool (5) (same side as spring (9)) and to the variable-displacement pump controller.

### F . Assembly procedure

To assemble the control valve unit, see Section 9Q01, §C.

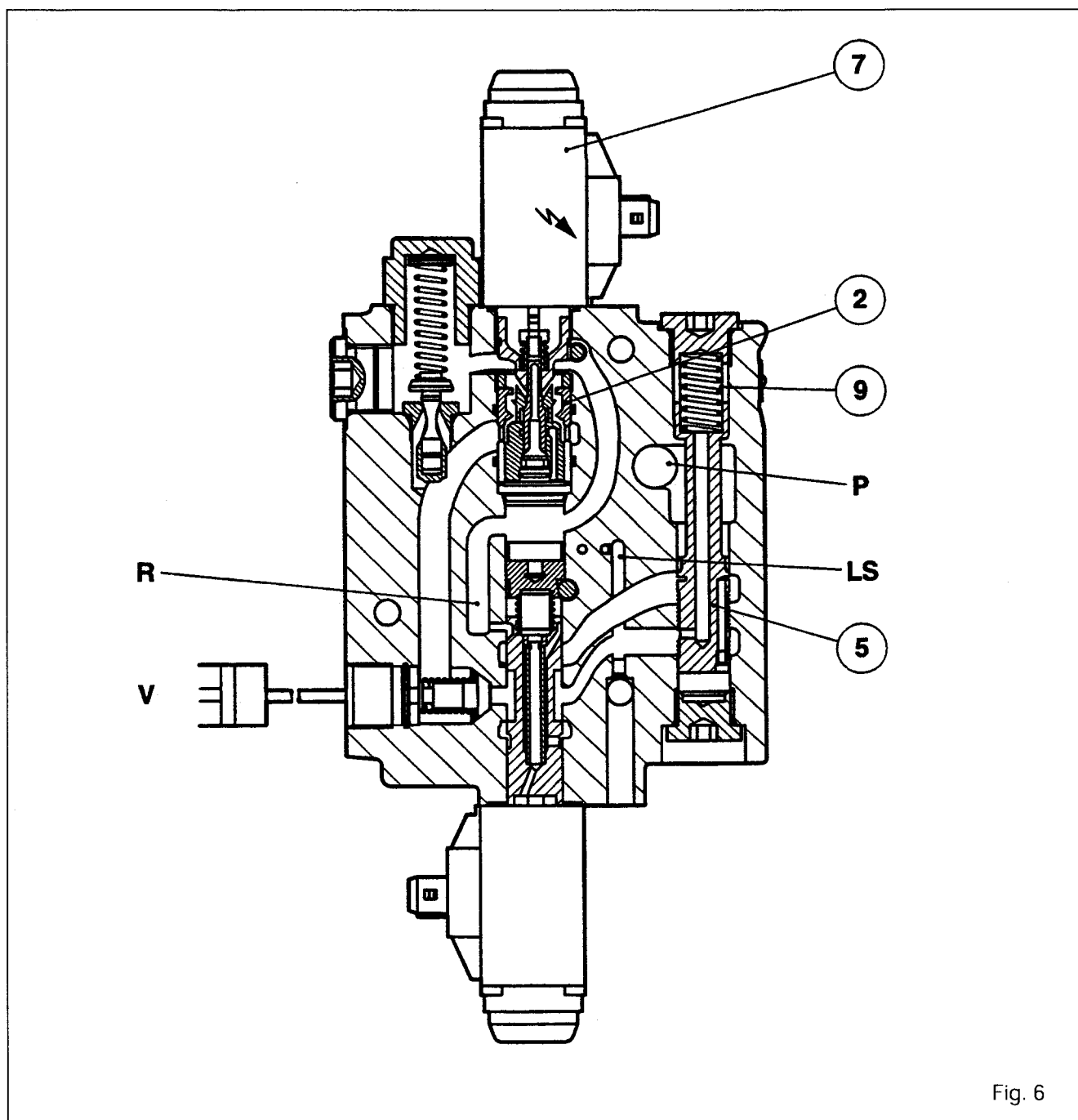

**Hydraulics** - Closed centre9 S01 *Hydrostatic steering*

## CONTENTS

-	<b>General</b> _____	<b>2</b>
A.	<b>Principle of Load Sensing</b> _____	<b>2</b>
B.	<b>Neutral position (engine running)</b> _____	<b>4</b>
C.	<b>Steering wheel turning (engine running)</b> _____	<b>5</b>
D.	<b>Manual steering (engine stopped)</b> _____	<b>6</b>
E.	<b>Disassembling and reassembling the distribution valve (Orbitrol)</b> _____	<b>8</b>





9S01.2

## 6100 SERIES TRACTORS



### Hydraulics - Closed centre

#### General

The steering system used on 6100 series tractors fitted with a six-cylinder engine is of the dynamic type (constant flow 0.5 l/mn - stand-by pressure 6 bar - see Section 9 N01 and 9 P01) with no mechanical linkage between the steering wheel and the steering cylinder.

Its control is based on the principle of "Load Sensing". The main components of the system are :

- a pressurised oil feed supplied by the high-pressure stage of the variable displacement pump
- an Orbitrol steering distribution valve (unit)
  - . OSPC 100 LS Dynamic 2WD
  - . OSPC 125 LS Dynamic 4WD
- a double-acting steering ram fitted on the 4WD front axle or the 2WD axle.

The Orbitrol unit is supplied by the high-flow circuit via the override units. When the steering wheel is turned, the required oil flow is sent to the relevant side of the steering ram. The excess flow not required by the ram is then directed via return ports to the selector cover installed on the gearbox, forming a reservoir with the centre housing.

In the case of failure of the engine or the variable displacement pump, the Orbitrol unit acts as a hand-operated pump so that the steering can be controlled.

#### Description of the distribution valve (Orbitrol)

The Orbitrol unit consists of a selector spool valve, a supply sleeve which is centred by springs and a drive shaft connected to the steering column. The Orbitrol unit has five ports, as follows :

- a pressure port
- a port for return to the selector cover
- two supply ports for the steering cylinder
- a Load Sensing port

The circuit is protected by a safety valve and two shock valves as well as two suction valves.

#### A . Principle of "Load Sensing"

##### Steering unit

Unlike the unit with an open centre type hydraulic system, the LSD steering unit is equipped with a fifth LS port.

This port is either connected to the Orbitrol closed circuit when the steering is in the neutral position or connected with the supply pressure line when the steering wheel is turned.

##### List of parts

- (1) Bolt
- (2) Bolt
- (3) O-ring
- (4) Cover plate
- (5) O-ring
- (6) Stator
- (7) Pin
- (8) O-ring
- (9) Rotor
- (10) Spacer
- (11) Link shaft
- (12) Washer
- (13) Centring springs
- (14) Needle-roller bearing
- (15) Bush
- (16) Washer
- (17) O-ring
- (18) Relief valve
- (19) Seal
- (20) Shock valve
- (21) Orbitrol distribution valve
- (22) Non-return valve
- (23) Suction valves
- (24) Ring
- (25) Spool valve
- (26) Check valve
- (27) Sleeve
- (28) O-ring
- (29) Distributor plate



**Hydraulics - Closed centre**

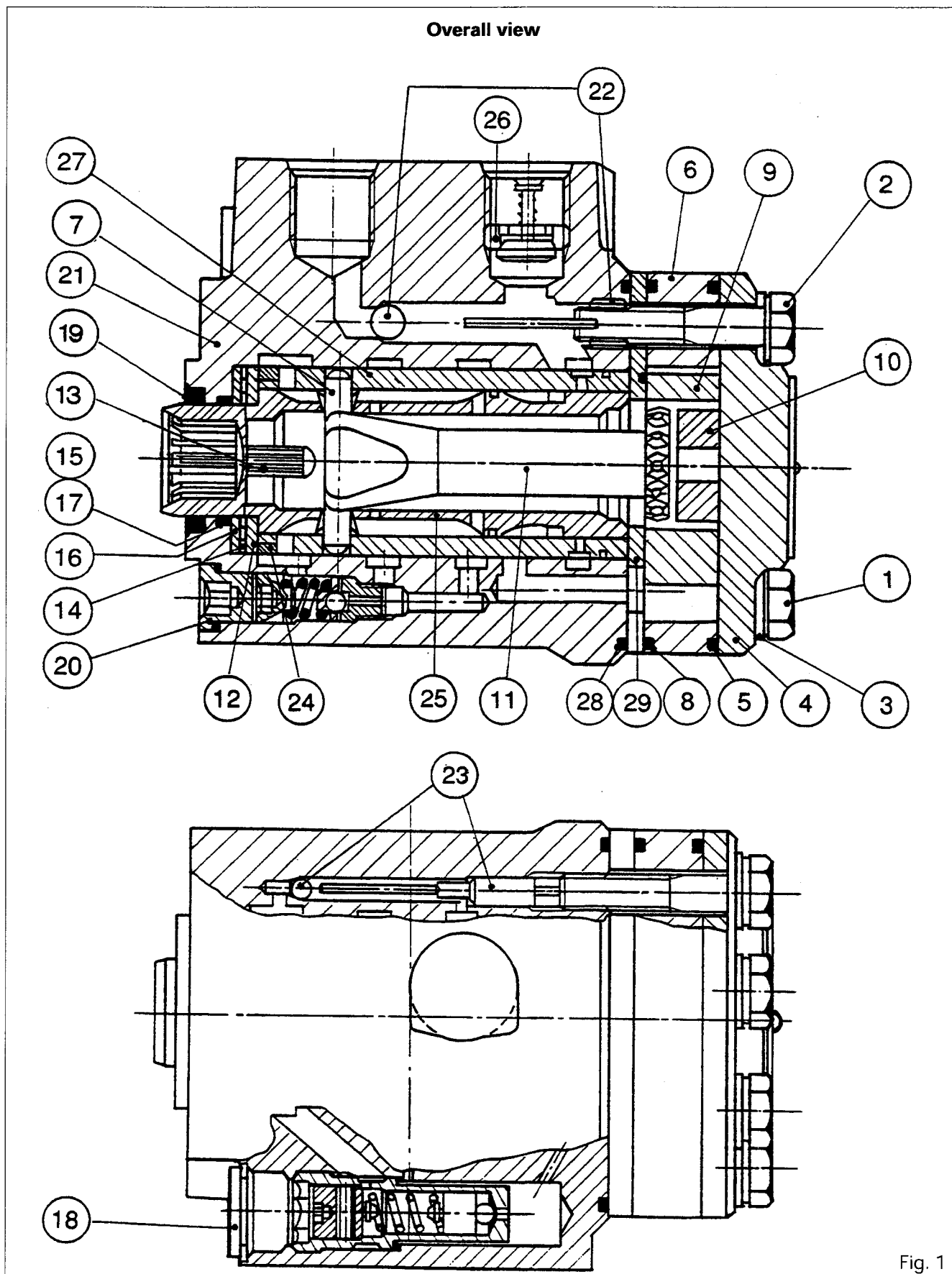

Fig. 1



9S01.4

## Hydraulics - Closed centre

### B. Neutral position (engine running) (Fig. 2)

In this position, the spool valve (25) is centred with respect to the sleeve (27) by means of springs (13). There is no supply to channels P1-L-R.

The flow coming from the variable displacement pump via channel (2) is directed, as priority, to the Orbitrol distributor via channel (1).

When the steering is in the neutral position, there is no flow in this channel.

Two shock valves (20) and two suction valves (23) are placed in ports L and R of this distribution valve.

The shock valves (20) protect the circuit between the steering ram and the distribution valve from any impact on the wheels.

The suction valves (23) allow the oil released by the shock valves (20) to flow from the right-hand channel to the left-hand channel or vice versa, depending on the displacement of the piston in the steering ram.

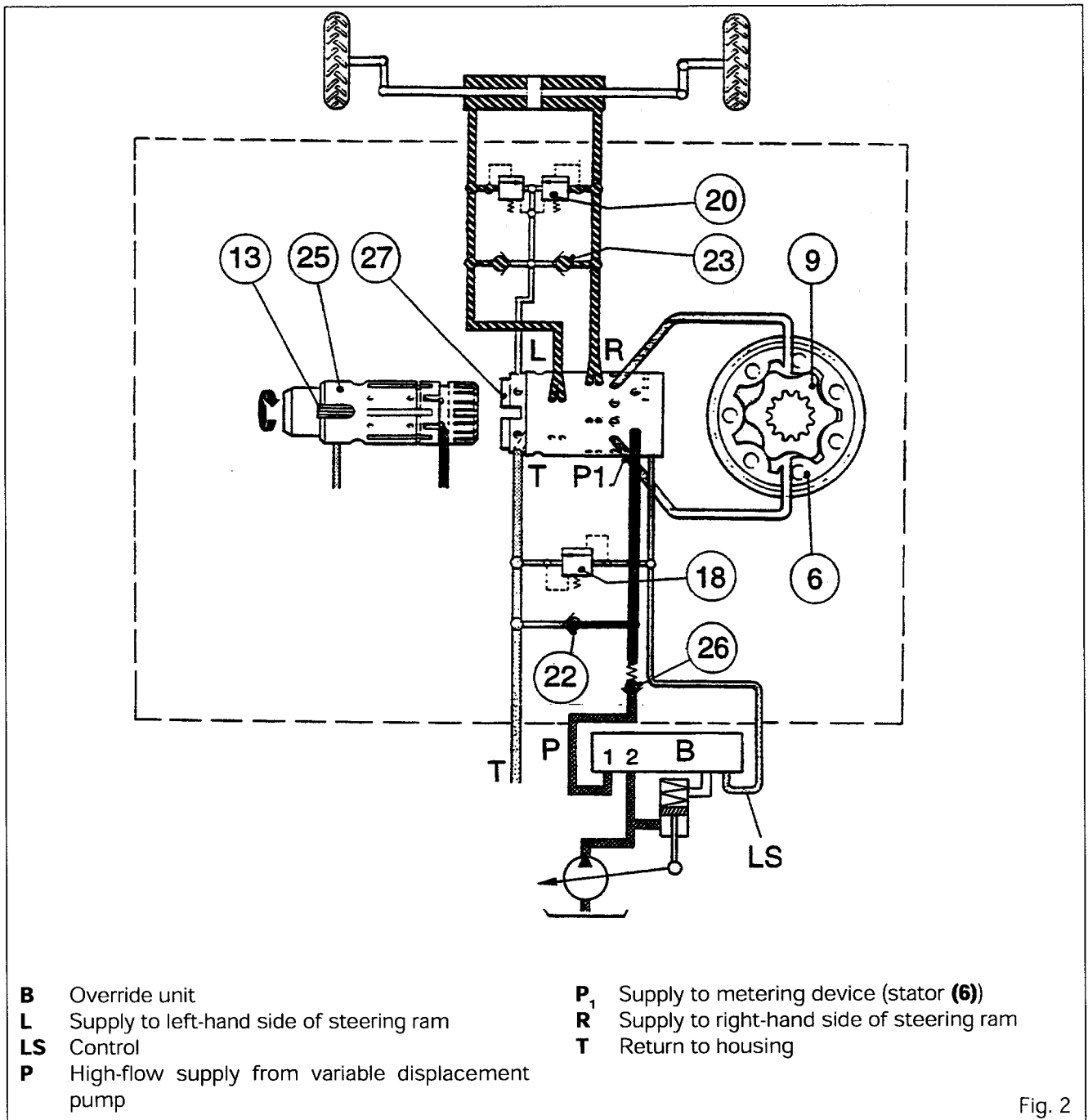

Fig. 2



## Hydraulics - Closed centre

### C . Steering wheel turning (engine running) (Fig. 3)

Action on the steering wheel (movement to the right or left) causes an angular shift of the spool valve (25) with respect to the sleeve (27) and opening of the Orbitrol closed circuit.

A pilot pressure from the Orbitrol unit is established in channel (4) and allows the flow required for the metering device (stator (6) and rotor (9)) to pass into channel (1).

The rotor (9) is driven in rotation and supplies the ram with a quantity of oil that is proportional to the angle of rotation. The rotation of the rotor (9) is equal to that of the steering wheel.

**Example :** Let us suppose that the steering wheel is turned through an angle of 5°. This causes an angular shift of 5° of the spool valve (25) with respect to the sleeve (27).

The rotor (9) is driven in rotation as long as it is supplied. It drives, with it, the link shaft (11) and the sleeve (27). When these have turned through 5°, the spool valve (25) and sleeve (27) are again centred by the springs (13). The rotor is no longer supplied and stops rotating.

This reasoning can be extended to greater angles. The quantity of oil delivered by the steering unit to the ram is, thus, proportional to the angle of rotation of the steering wheel.

Depending on whether the steering wheel is turned to the left or to the right, the spool valve (25) directs the oil delivered by the metering device (stator (6) and rotor (9)) to port L or R. During the rotation, the sleeve (27) ensures that the cavities in the metering device are set into synchronous communication with the circuit from the pump, on the one hand, and the circuit to the ram, on the other hand.

A check valve (26) is screwed into the distribution valve supply port. This is a one-way valve which prevents excess pressures exerted on the wheels from being transmitted to the pump when the wheels are turned.

If the pressure in the steering system is too high, the relief valve (18), located in the distribution valve, is actuated and the excess pressure is routed to channel T.

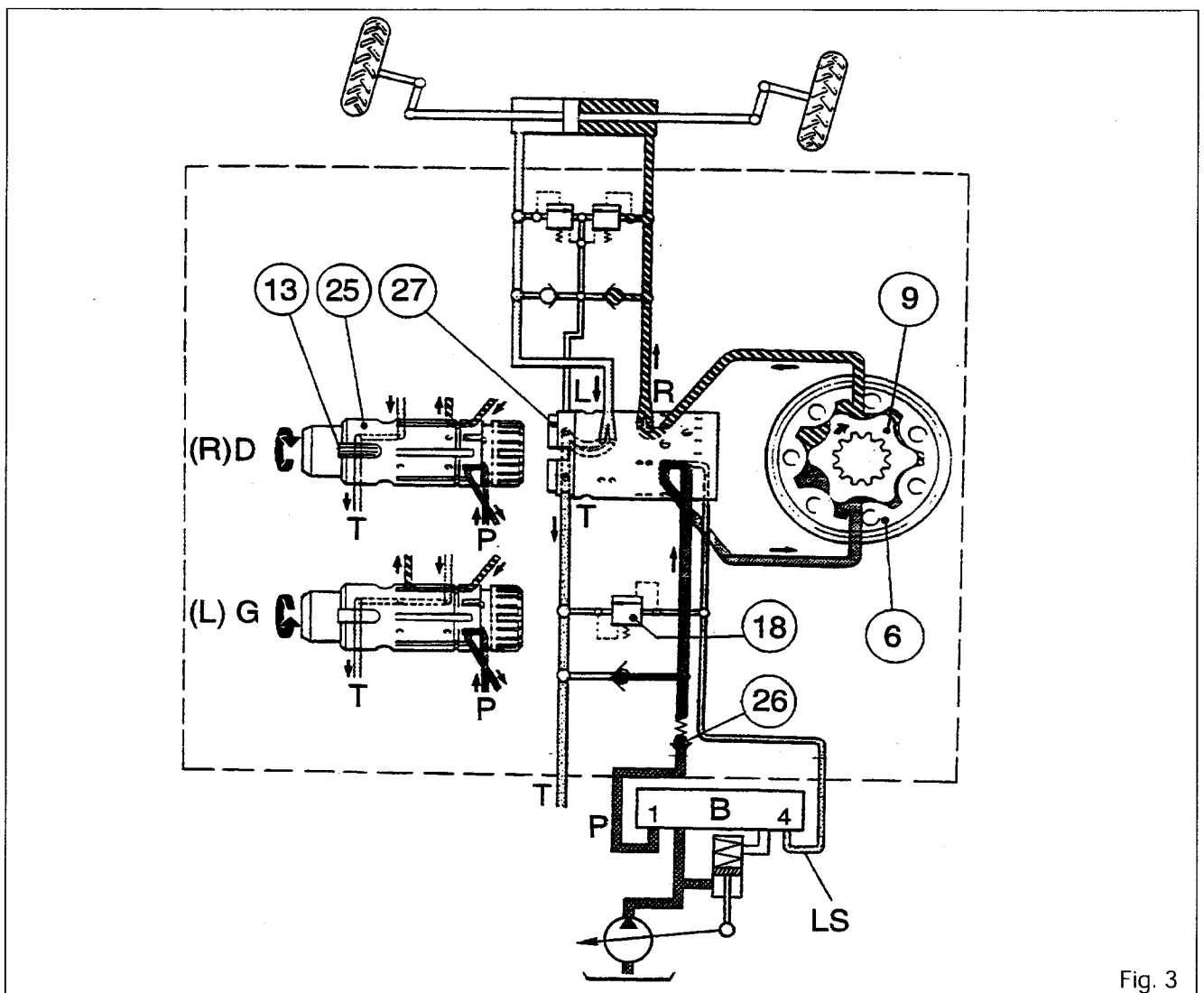

Fig. 3



9S01.6

## Hydraulics - Closed centre

### D. Manual steering (engine stopped) (Fig. 4)

When there is no more flow from the pump or when the available pressure is too low, the rotor (9) is no longer driven hydraulically. Power assistance is no longer provided.

In this case, action on the steering wheel compresses the centring springs (13). The angular play between the pin (7) and the sleeve (27) is taken up and the metering device (stator (6) and rotor (9)) is driven mechanically. The distribution valve then functions like a hand-operated pump.

The oil returning from the cylinder passes via the non-return valve (22) and supplies the metering device.

The pressure generated is proportional to the torque applied on the steering wheel. In this case, considerable force is required on the steering wheel.

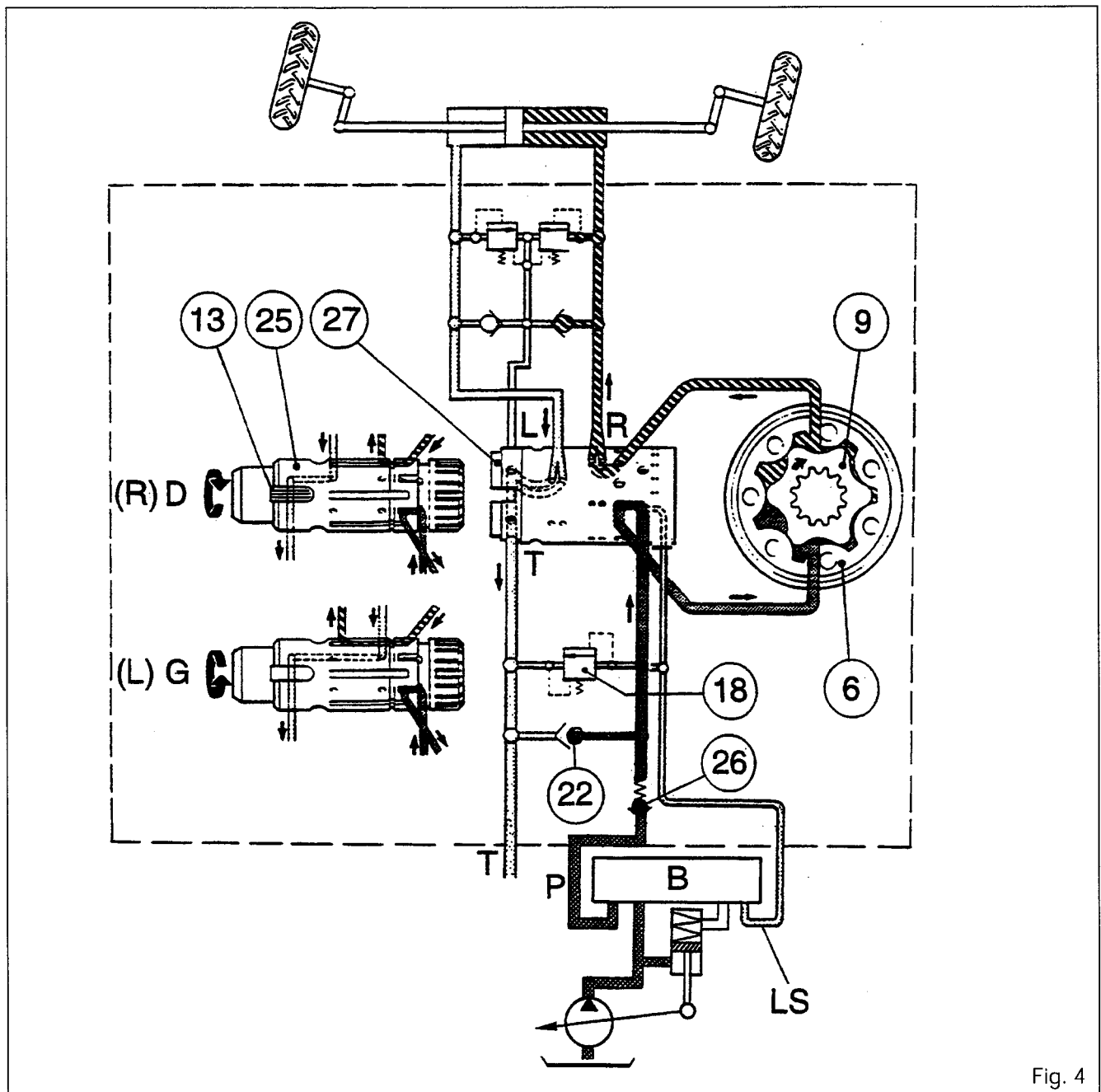

Fig. 4



**Hydraulics - Closed centre**

9S01.7

Exploded view

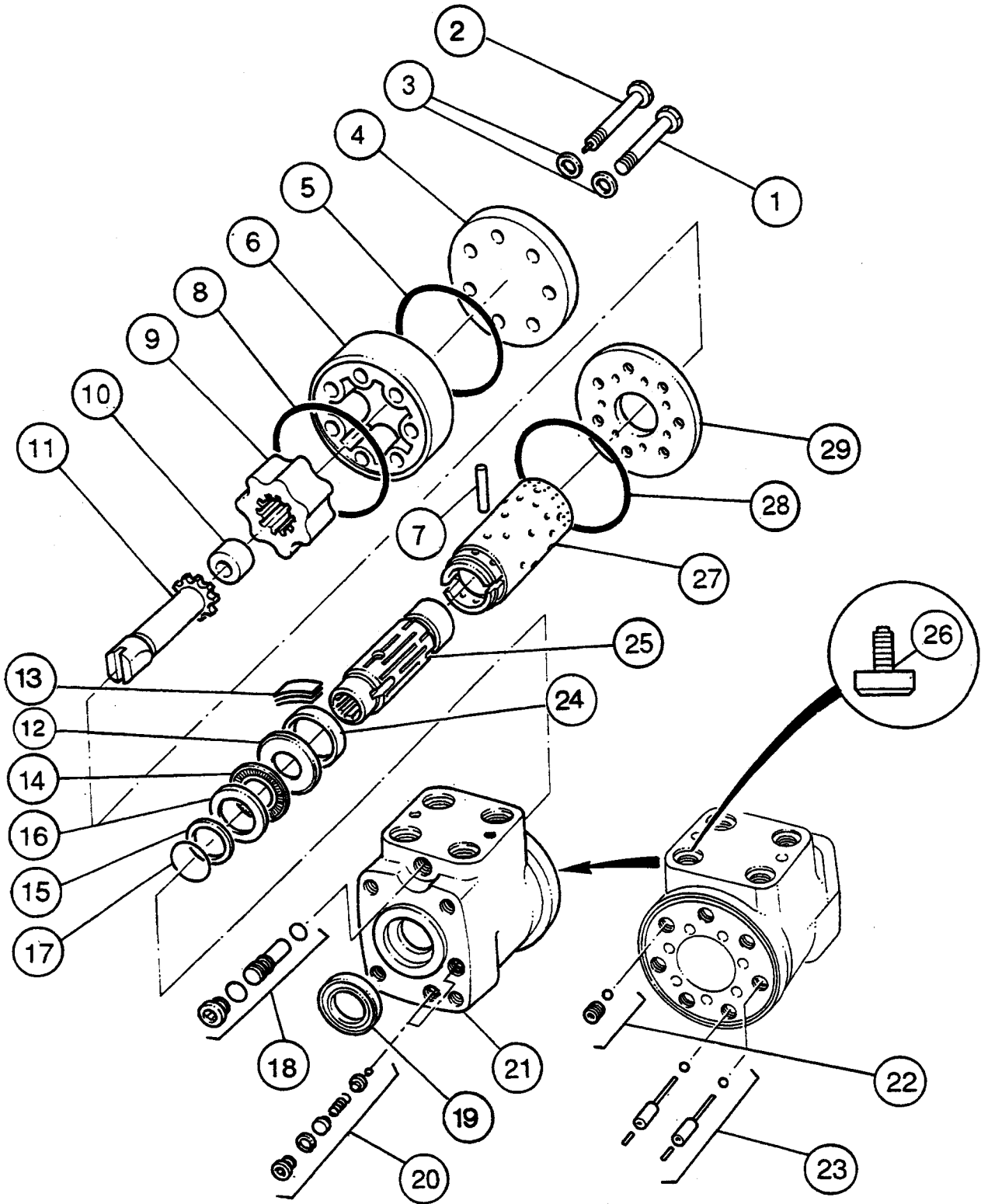
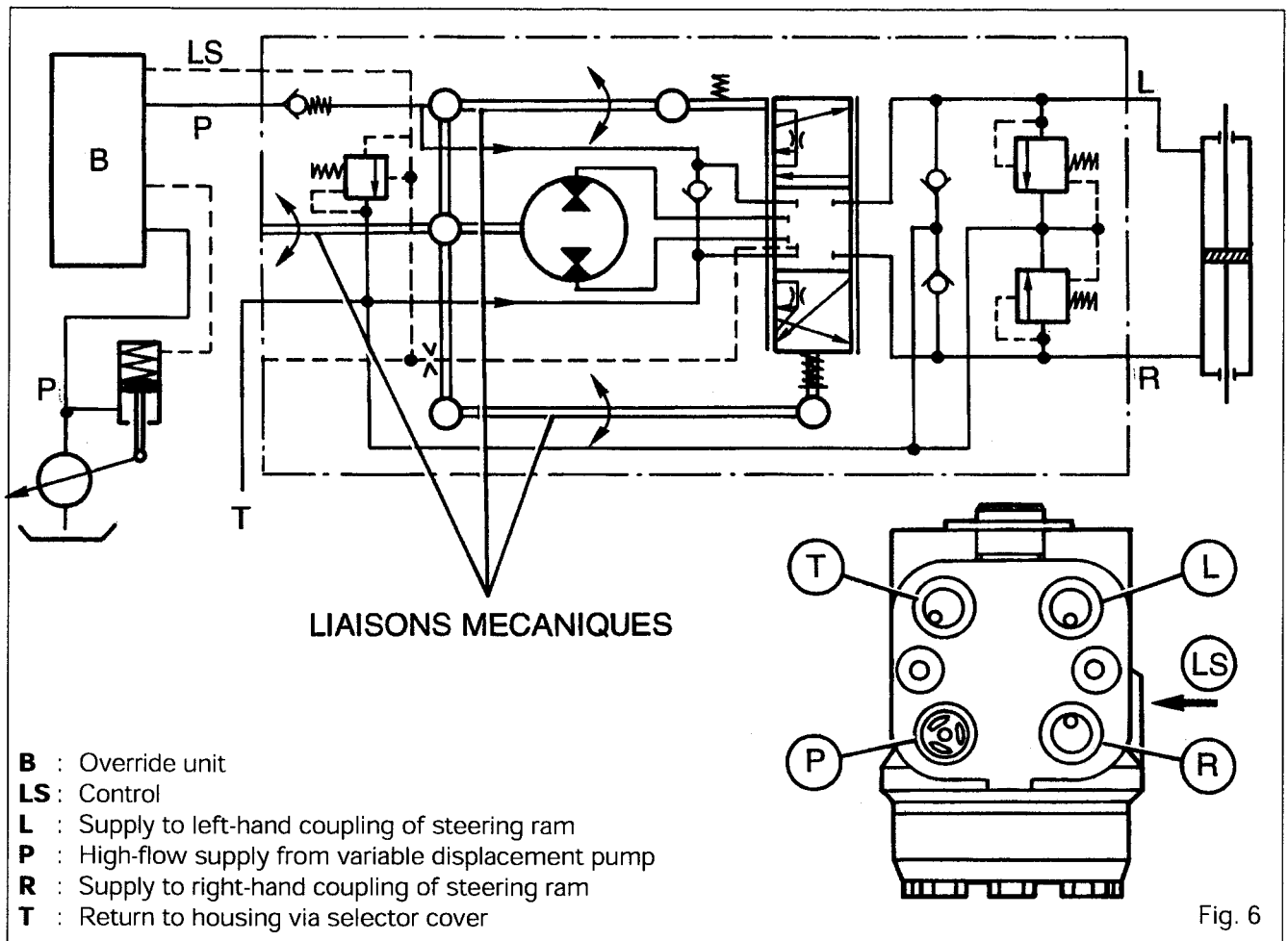

Fig. 5



9S01.8

## 6100 SERIES TRACTORS

**Hydraulics - Closed centre**

### E . Disassembling and reassembling the distribution valve (Orbitrol) (Fig. 1)

#### Disassembly

1. Remove the distribution valve from the tractor.
2. Place the distribution valve in a vice fitted with plastic jaws.
3. Remove bolts (1). Mark the position of bolt (2) and remove it.
4. Remove the cover plate (4), O-ring (5), the stator (6) and O-ring (8).
5. Remove the spacer (10), rotor (9), distributor plate (29) and O-ring (28).
6. Withdraw the splined link shaft (11).
7. Unscrew the threaded bush and recover the ball from the non-return valve (22).
8. Withdraw the two pins and the two balls from the suction valves (23) of the distribution valve.
9. Extract the sleeve (27) and spool valve (25) assembly by pushing it, making sure that the pin (7) is horizontal.
10. Remove the washers (12) and (16), the needle-roller bearing (14) and the ring (24) from the sleeve/spool valve assembly. Remove the pin (7) and the centring springs (13) by pressing on one of their ends. Separate the sleeve (27) from the spool valve (25).
11. Unscrew the cap of the relief valve (18). Using an 8 mm Allen key, remove the threaded bush and take out the seal, the spring and the valve. (The crimped seat is not removable).
12. Unscrew the two caps from the shock valves (20), and remove the seals. Using a 6 mm Allen key, remove the threaded bushes and take out the springs, the balls and their seats. (The crimped seats are not removable).
13. Extract the seal (19), the bush (15) and O-ring (17).
14. Remove the check valve (26).



## Hydraulics - Closed centre

### Reassembly

15. Check and clean the parts, and replace any that are faulty. Lubricate parts with clean transmission oil before reassembling.
  16. Refit the check valve (26).
  17. Fit seal (19), O-ring (17) and bush (15).
  18. Place the balls and springs in the recesses for the shock valves (20). Screw in the threaded bushes, position the seals and tighten the caps.
  19. Place the valve and spring in the recess for the relief valve (18) and screw in the threaded bush. Position the seal and tighten the cap to a torque of 40 to 60 Nm.
  20. Insert the spool valve (25) in the sleeve (27). Position the centring springs (13) as shown in Figure 7 and fit the pin (7).
  21. Position the ring (24) on the sleeve and spool valve assembly so that the chamfer facilitates assembly in the distribution valve.
  22. Fit washers (12) and (16) with the chamfer on washer (12) directed towards the centring springs (13) and with the needle-roller bearing (14) positioned between them.
  23. Fit the sleeve and spool valve assembly in the distribution valve, applying a slight oscillating movement. Check that the pin (7) is held horizontally.
  24. Place the two balls and the two pins in the recesses for the suction valves (23).
  25. Place the ball in the recess for the non-return valve (22) and screw in the threaded bush.
  26. Position the splined link shaft (11).
  27. Fit O-ring (28) and the distributor plate (29).
  28. Fit the rotor (9) so that the two hollows "C" are in line with the slot in the splined shaft (11) (Fig. 8). Refit the spacer (10).
  29. Place O-rings (5) and (8) on the stator (6).
  30. Taking care not to move the rotor (9), fit the stator (6). Then move the stator so that its attachment holes coincide with those of the distribution valve.
- Note : The rotor (9) and pin (7) must be in the position shown in Figure 9.**
31. Refit the cover plate (4).
  32. Refit bolt (2) (in the position marked during disassembly) and bolts (1) fitted with their seals (3). Tighten them alternately to a torque of 30 to 35 Nm.

33. Using a test bench or a suitable fixture, check the adjustment and operation of the distribution valve.
34. Refit the distribution valve on the tractor.
35. Check the couplings for leaks.

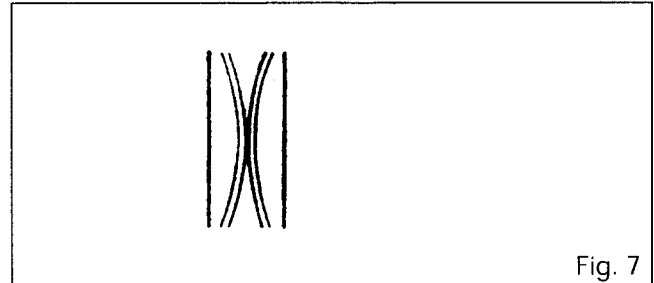

Fig. 7

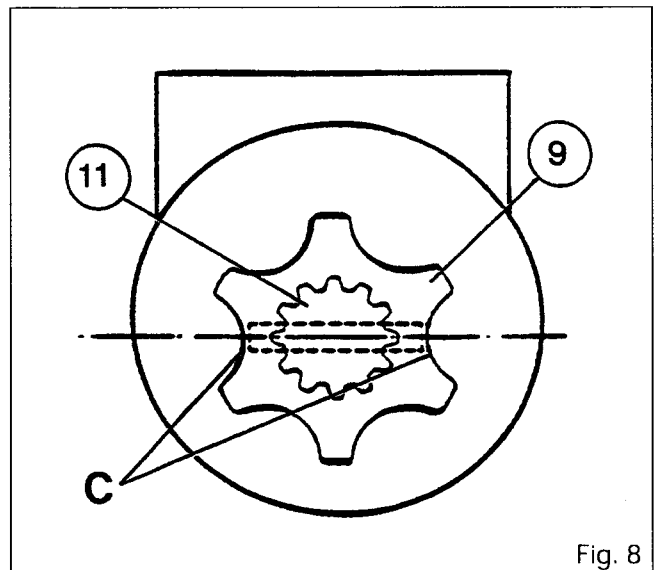

Fig. 8

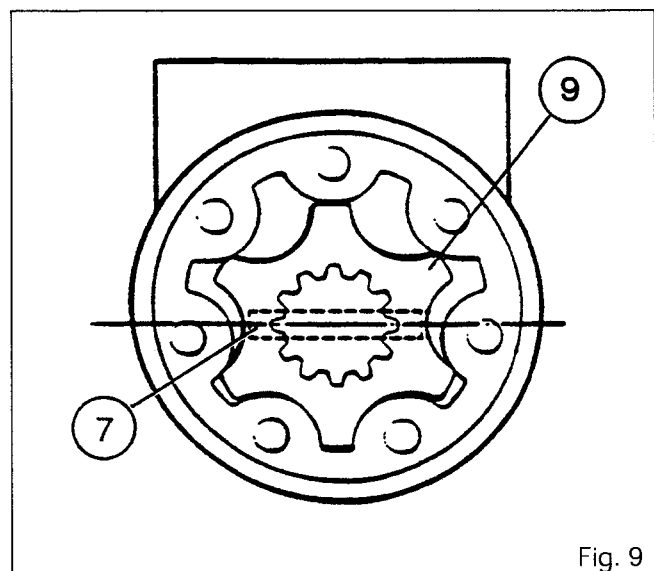

Fig. 9







---

6100 SERIES TRACTORS

---

**Hydraulics - Closed centre**



9T01.1

9 T01 *Right-hand hydraulic cover*

CONTENTS

- <b>General</b> _____	2
<b>A. Removing and refitting the cover</b> _____	9
<b>B. Description and operation of the variable-displacement pump</b> _____	11
<b>C. Removing and refitting the pump</b> _____	14



9T01.2

## Hydraulics - Closed centre

### General

The right-hand cover fitted on the rear axle housing has the same functions as the cover for the hydraulic system of the open centre type :

- It serves as a support for many components.
- It comprises various channels of the booster, lubrication and low flow circuits.

The internal face of the cover accommodates :

- the variable displacement pump **(41)** and its driving gear **(39)**,
- the safety valve **(45)** of the low pressure circuit calibrated at 22 bars
- the safety valve **(44)** of the booster and lubrication circuit calibrated at 5 bars

On its external faces, it is fitted with :

- the 15-micrometre main filter **(27)**,
- an override unit or trailer brake unit (according to option) used for the various functions of the circuits (low and high flow),
- the pressure relief valve **(2)**,
- the variable-displacement pump controller **(12)**,
- 4 or 5 solenoid valves **(15)** to **(19)** controlling the low pressure functions (according to option),
- the diagnostic connectors: high and low pressure **(11)** and **(20)**, lubrication and booster **(29)** and LS **(9)**,
- the engine speed sensor,
- the low pressure **(14)** and booster **(42)** switches and the main filter clogging indicator **(34)**.

- (21)** Plug
- (22)** Piloting from brake master cylinders
- (23)** PTO brake union
- (24)** 2WD or 4WD differential lock union
- (25)** Engine speed sensor
- (26)** 4WD union
- (27)** Main filter, 15 micrometres
- (28)** LP union
- (29)** Booster and lubrication pressure diagnostic connector
- (30)** Supply to lift control valve and auxiliary spool valves
- (31)** LS piloting to auxiliary spool valves and lift control valve
- (32)** Bolt
- (33)** Trailer brake hose
- (34)** Clogging indicator
- (35)** Bolt
- (36)** Locating dowels
- (37)** Nut
- (38)** Washer
- (39)** Gear
- (40)** Key
- (41)** Variable-displacement pump
- (42)** Booster and lubrication pressure switch
- (43)** Union and pipe to cooler
- (44)** Safety valve, 5 bar
- (45)** Safety valve, 22 bar
- (46)** Heat-sensitive switch
- (47)** Pump attaching bolt
- (48)** Nuts
- (49)** Studs

### List of parts

- (1)** Bolt
- (2)** Pressure relief valve
- (3)** Supply to Orbitrol
- (4)** Bolt
- (5)** LS piloting from Orbitrol
- (6)** LS piloting to pump controller
- (7)** Override unit or trailer brake unit (if fitted)
- (8)** Cover
- (9)** LS diagnostic connector
- (11)** HP diagnostic connector
- (12)** Pump controller
- (13)** Union (LS)
- (14)** LP switch (17 bars)
- (15)** Solenoid valves (PTO, PTO brake, to differential lock (front and rear), **(19)** and 4WD)
- (20)** LP diagnostic connector



Outside overall view

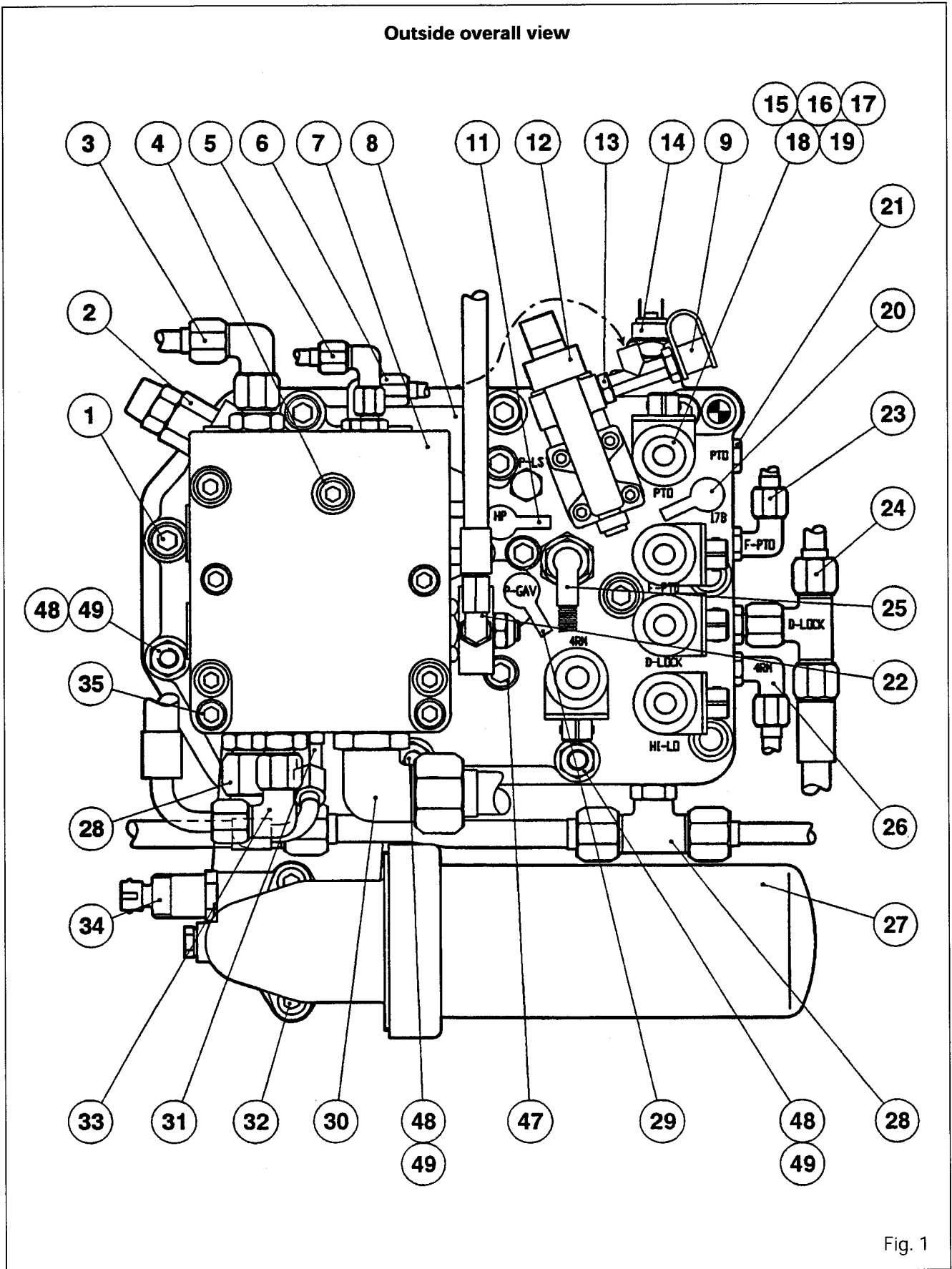

Fig. 1



9T01.4

6100 SERIES TRACTORS



**Hydraulics - Closed centre**

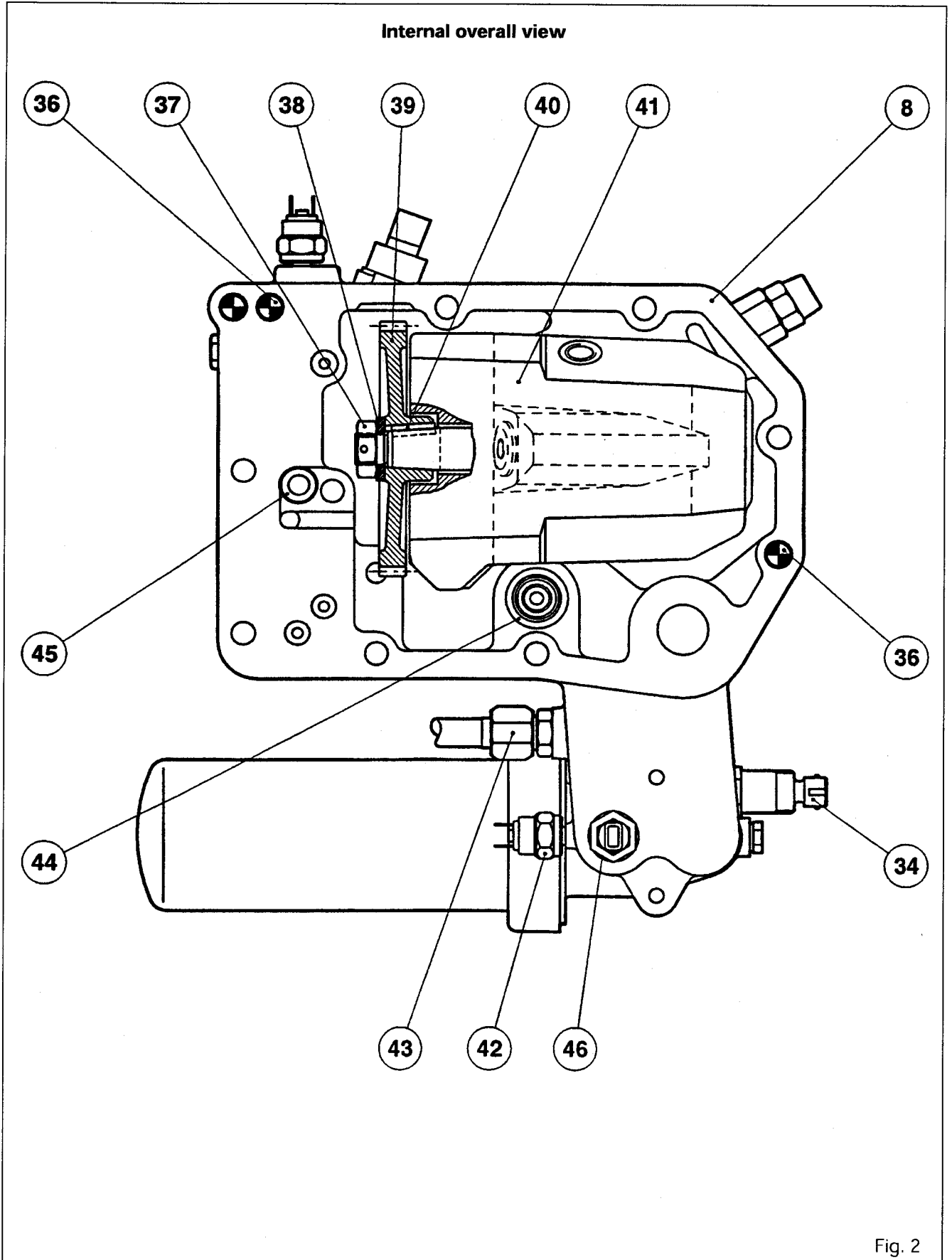

Fig. 2



**Hydraulics - Closed centre**

Exploded view

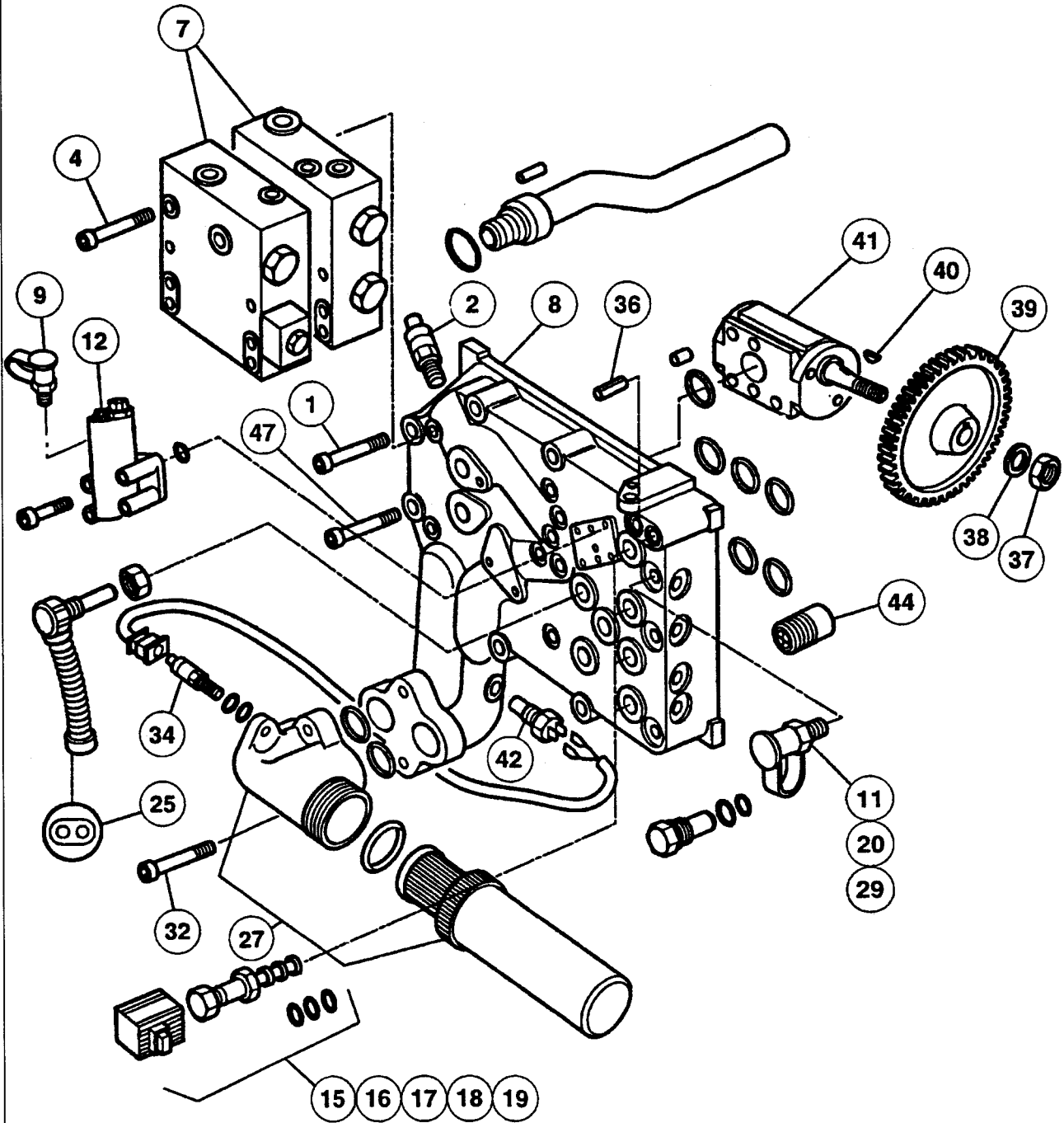

Fig. 3



# Hydraulics - Closed centre

Identification of ports and channels (Figures 4 and 5)

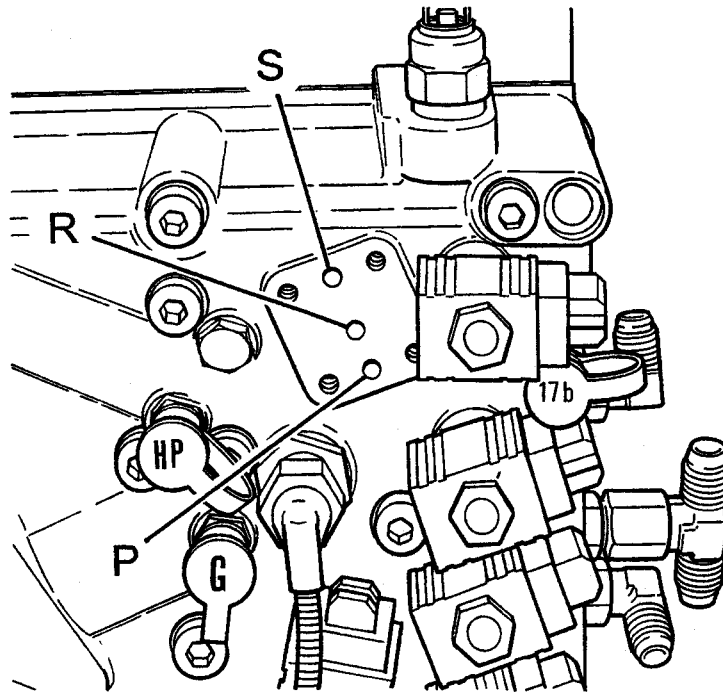
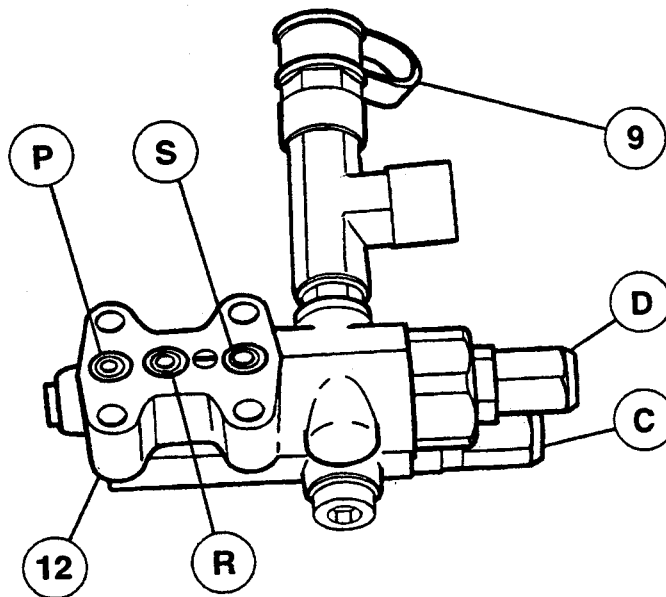

Fig. 4



- C** : Adjusting screw, 22-bar
- D** : Adjusting screw, 200-bar
- G** : Booster
- P** : HP pressure from variable-displacement pump
- R** : To variable-displacement pump control piston
- S** : Controller return
- HP** : High-pressure

- (9)** LS diagnostic connector
- (12)** Pump controller

**Important : Adjusting screws C and D are pre-set. These settings should not be modified.**

Fig. 5



Identification of ports and channels (Figures 6 and 7)

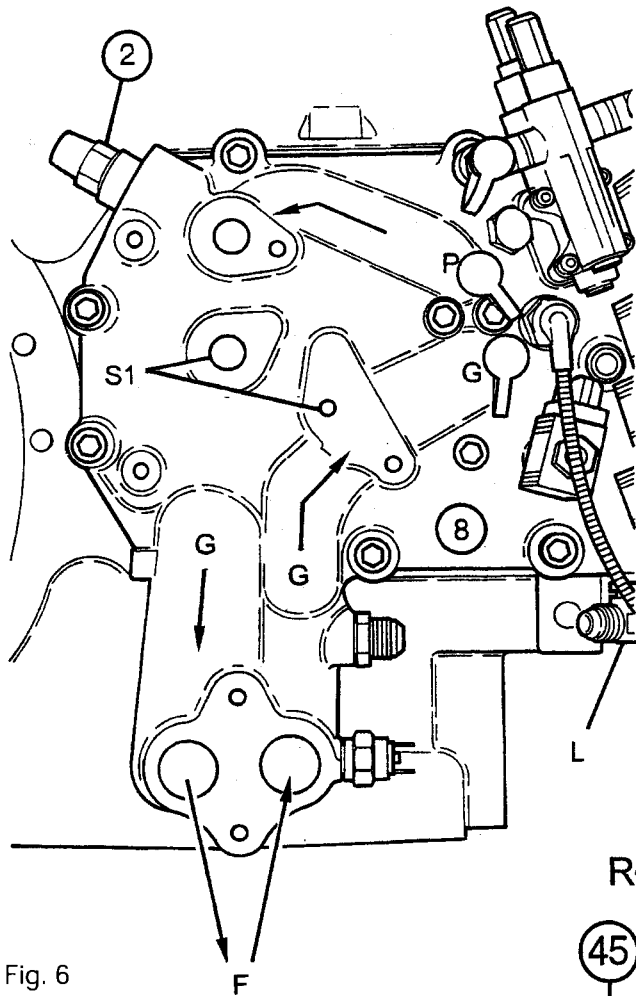

Fig. 6

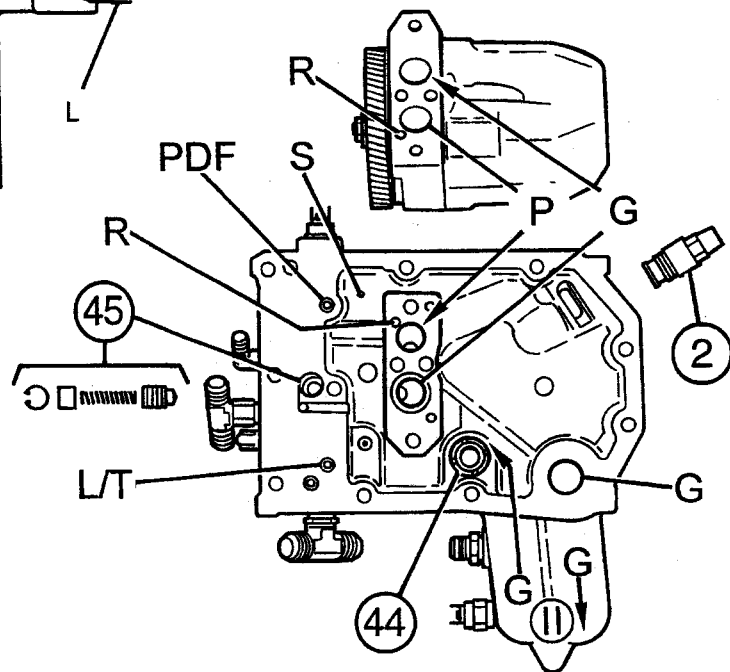

Fig. 7

- F** : Main filter, 15 micrometres
- G** : Booster
- L** : Lubrication (to cooler)
- P** : HP pressure from variable-displacement pump
- R** : To variable-displacement pump control piston
- S** : Controller return
- S1** : Return for override unit or trailer brake unit (if fitted)
- H/T** : Hare/Tortoise (Hi/Lo)
- PTO** : Power take-off

- (2)** Pressure relief valve
- (44)** Safety valve, 5 bar
- (45)** Safety valve, 22 bar







## Hydraulics - Closed centre

### A . Removing and refitting the cover

#### Removal (Fig. 8)

1. Immobilise the tractor. Fit wedge blocks under the left-hand rear wheel.
2. Fit wedges between the frame and the front axle.
3. Partially drain the centre housing.
4. Remove the wheel on the relevant side. Install a stand.
5. Disconnect the pipes or hoses **(3)**, **(5)**, **(6)**, **(23)**, **(24)**, **(26)**, **(28)**, **(30)**, **(31)**, **(33)** and **(43)**, the cable harnesses for the solenoid valves **(15)** to **(19)** (according to version), the switches **(14)**, **(42)**, **(34)** and **(46)** and the engine speed sensor **(25)**.
6. Remove bolts **(32)**. Remove the main filter assembly **(27)**.
7. Remove bolts **(4)**. Remove the override unit or the trailer brake unit (if fitted).
 

**Note: To avoid having to bleed the trailer brake system, it is advisable to remove the brake unit without disconnecting the pilot hose (22) from the master cylinders.**
8. Remove bolts **(1)** and nuts **(48)**. Detach and remove the cover.

#### Special points

- An upper bolt on the cover is hidden by the union screwed onto the controller **(12)**. The controller should be removed to facilitate removal of the cover.
- If it is necessary to remove the suction pipe **(1)**, remove the bolt **(2)** (Fig 9). Orient the pipe as required and remove it by manoeuvring it through the opening in the cover.
- To remove the safety valve **(45)** on the LP circuit, compress the spring **(3)** with a screwdriver and remove the circlip **(1)**. Remove components **(2)** to **(4)** (Fig. 10). Check that the valve **(4)** slides freely in its housing.

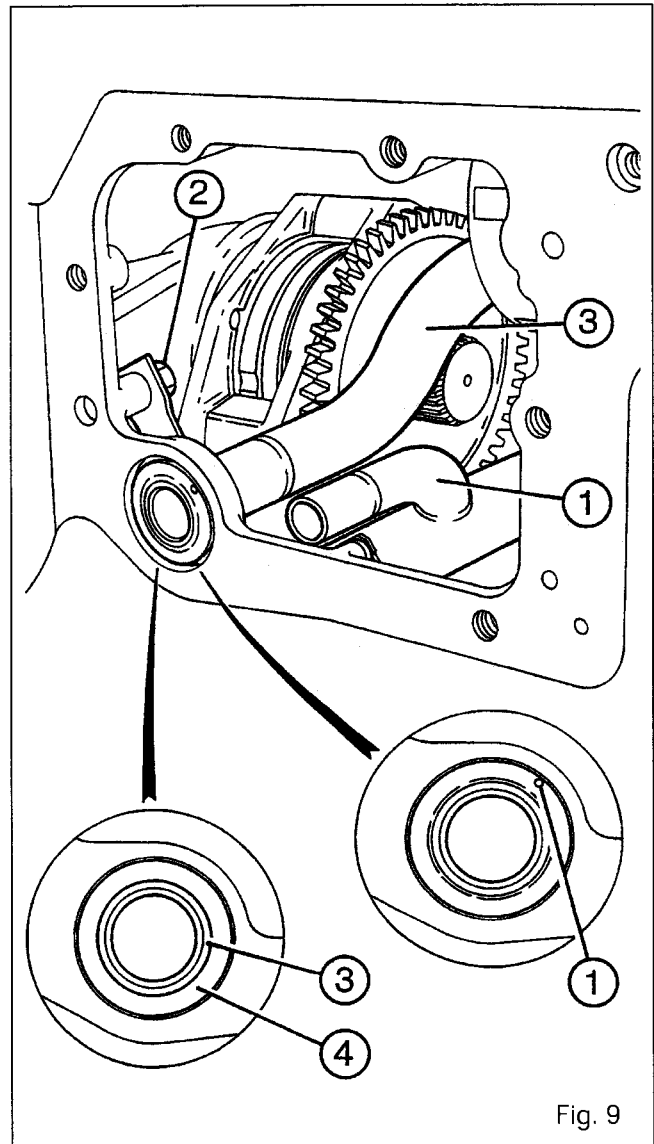

Fig. 9

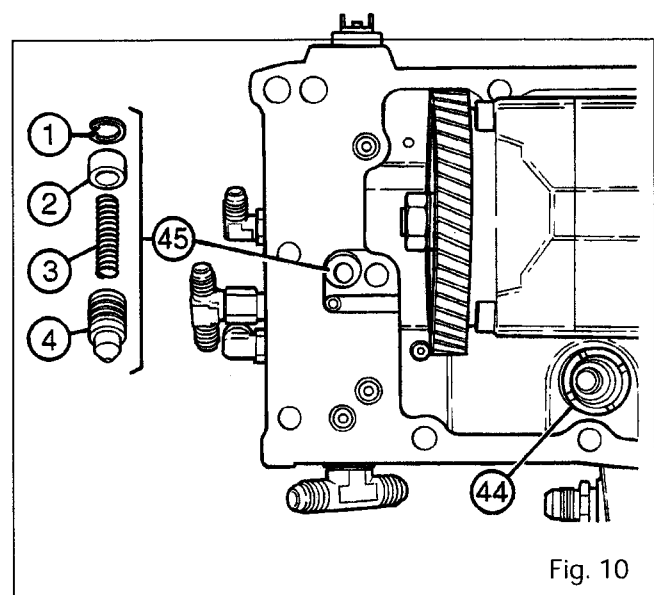

Fig. 10



9T01.10

## 6100 SERIES TRACTORS

**Hydraulics - Closed centre****Refitting**

9. Clean the mating faces on the housing and cover.
10. Check that the two locating dowels (36) are in place. Replace the O-rings on the H/T and PTO channels (Fig. 11).
11. Fit the suction pipe (1) if it was removed. Tighten the bolt (2). Fit the booster pipe (3) with the notch in the dowel (1). Lightly smear the seal (4) with miscible grease and position it on the flange of the pipe (3) (Fig. 9).
12. Smear the mating face on the cover with a sealing compound (Loctite 510 or equivalent) without blocking the Hare/Tortoise and PTO ports.
13. Fill the pump (41) with transmission oil via port "O" (Fig. 8).
14. Slide the cover onto the studs and apply it onto the centre housing, checking that the suction pipe (1) is correctly positioned on the 5-bar valve (48) between the mating faces between the cover and the housing (Fig. 12).
15. Tighten the bolts (1) to a torque of between 120 and 160 Nm and the nuts to between 90 and 120 Nm.
16. Replace the O-rings (1) to (3) (Fig. 13) and reinstall the override unit or the trailer brake unit (if fitted). Smear the bolts (4) with Loctite 542 and tighten them to a torque of between 25 and 35 Nm (Fig. 8).
17. Reconnect the engine speed sensor, the switches, the solenoid valve harnesses and the pipes.
18. Raise the tractor and refit the wheel. Remove the axle stand and tighten the wheel nuts to a torque of 400 to 450 Nm.
19. Top up the oil in the centre housing.
20. Check the operation of the electric circuits, the LP switch (14), the booster switch (lubrication) (42), the clogging switch (34), the heat-sensitive switch (46) and the solenoid valves.
21. Check for leaks on the cover mating face and the hydraulic unions.

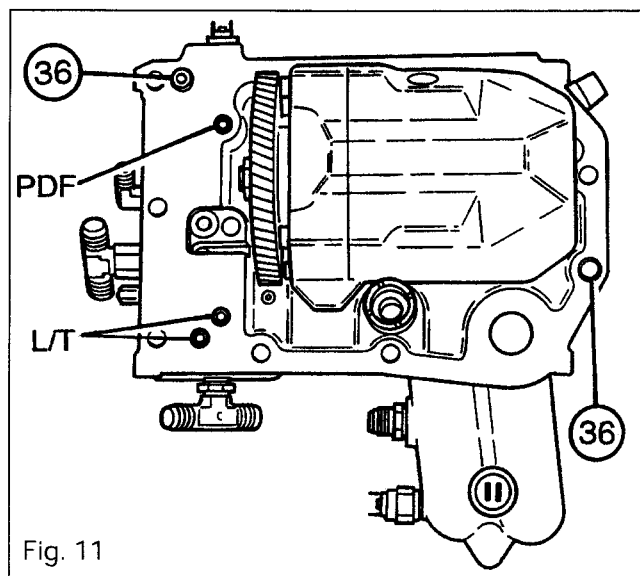

Fig. 11

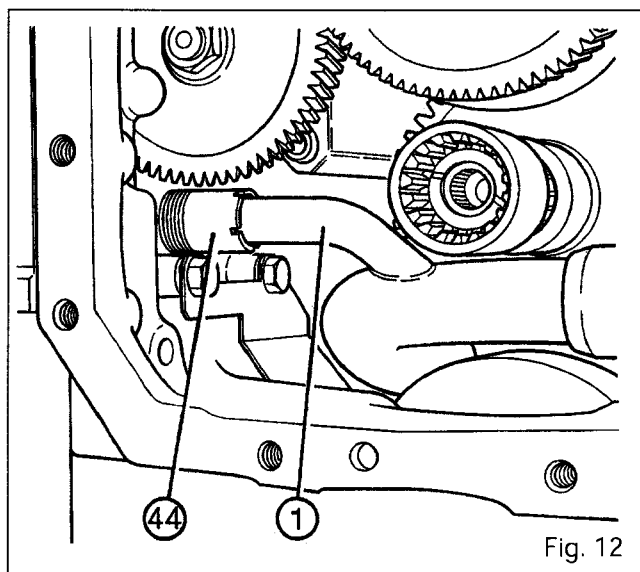

Fig. 12

**Special points**

- Sensor (25): Smear the threads with Loctite 577 Sensor Sealing compound or equivalent.
- Booster switch (lubrication) (42), LP switch (14) and heat-sensitive switch (46): Lightly smear the threads with Loctite 542.
- If a replacement pump has to be fitted (see part C), repeat the hydraulic tests (see Section 9V01).

**Tightening torques**

- Solenoid valves (15) to (19): 18 to 20 Nm,
- Knurled nuts: 4 to 5 Nm.
- 5-bar safety valve (44): Coat the threads with Loctite 241 and tighten to between 10 and 20 Nm using the locally manufactured tool.
- Sensor locknut (25): 10 to 15 Nm.
- Pressure relief valve (2): 150 Nm.

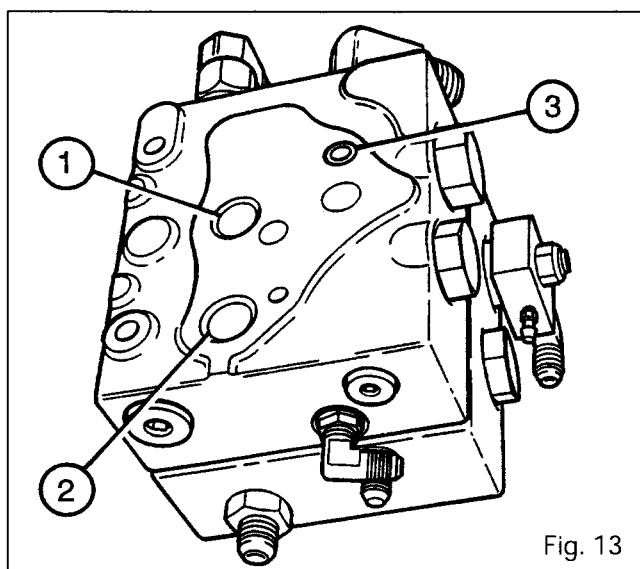

Fig. 13



## Hydraulics - Closed centre

### B . Description and operation of the variable-displacement pump

#### Description (Fig. 14)

The variable-displacement pump installed inside the right-hand cover is driven by the external teeth on the PTO clutch.

It consists of a body (1) and a barrel (3) driven by the shaft (13). The barrel has nine axial pistons (4) bearing on ball joints (5) which are in contact with the plate (6) via shoes (7).

The slope of the plate is obtained by balancing between the spring (8), the push-rod (9) and the piston (10) actuated by a controller receiving the LS pilot pressure from the high-pressure components via the override units.

The travel of the axial pistons (4) is modified according to the slope of the plate, so that the flowrate can be adapted to operating conditions.

The distribution plate (11) to the rear of the ball established communication between the piston chambers and the pump suction and discharge ports. The ball joints (5) have holes to ensure lubrication between the shoes (7) and the plate (6). The oil is then routed to the housing via port "O" (Fig. 8).

The pressure relief valve (2) is screwed into the upper left-hand section of the cover (Fig. 1).

The controller (12), including the diagnostic connector (9) (LS signal), communicates with the pump via the ports in the cover (Figures 4 and 5).

The diagnostic connector (11) is used to monitor the high pressure on the pump outlet.

#### Operation (Figures 14, 15 and 16)

##### Stand-by position

When the engine is stopped, the pump is automatically set to its maximum flowrate position. When the engine is started up, no flow is necessary in theory. The pressure in line P increases. When it reaches 22 bars, it pushes the spool a and is placed in communication with port R of the controller. The pressure acts on the piston (10) and the push-rod (9) of the pump which causes the plate (6) to slope, positioning it in the zero flow position. In practice, a low flow at less than 6 bars is maintained in the steering circuit, increasing the stand-by pressure to 28 bar.

##### Principle of the working function

The spool a is in balance between the LS pressure and the spring, on the one hand, and the output pressure P from the pump, on the other hand.

The pump supplies the receiver to maintain the spool a in its balanced position: pressure P = pressure LS + 22 bar.

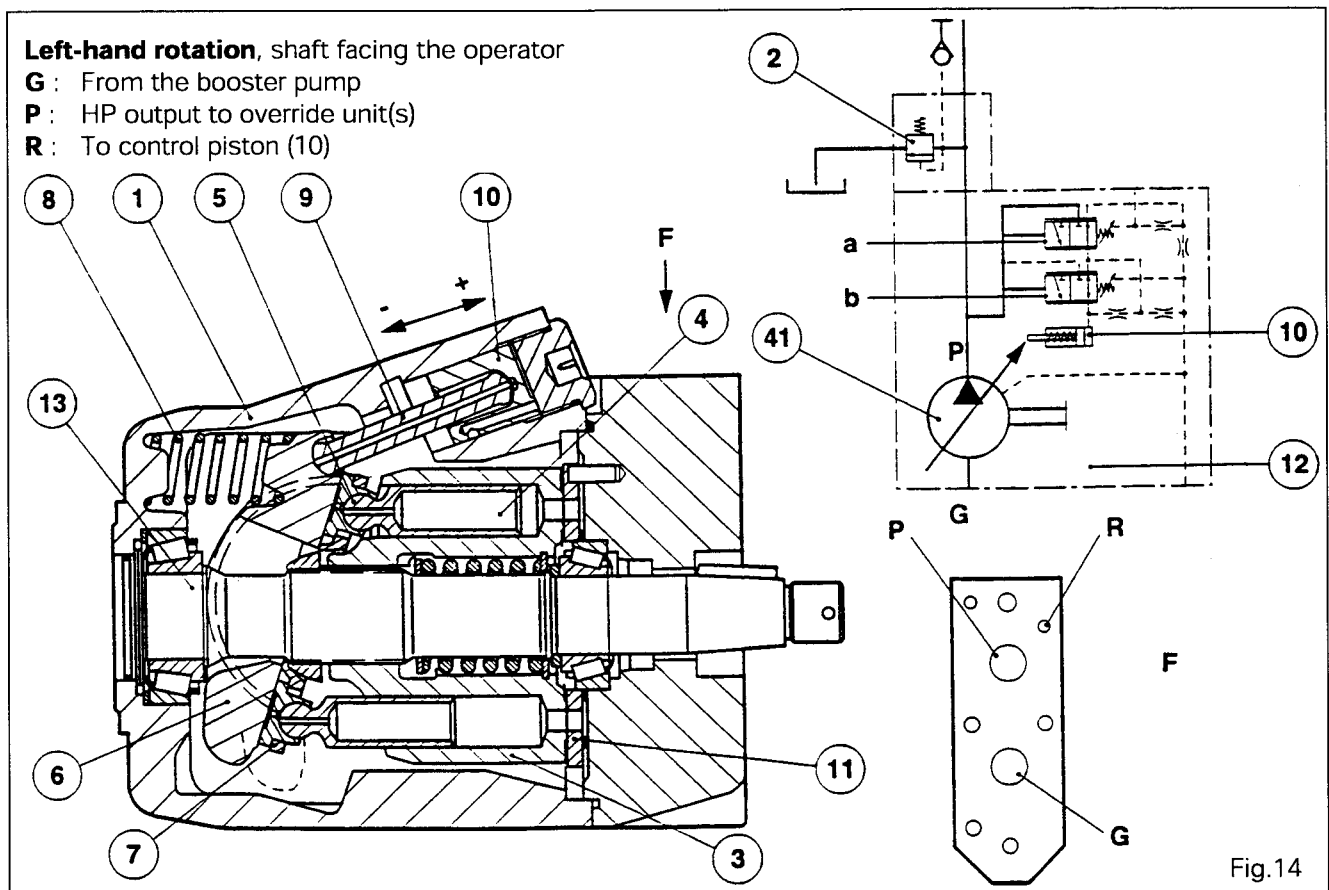



9T01.12

# Hydraulics - Closed centre

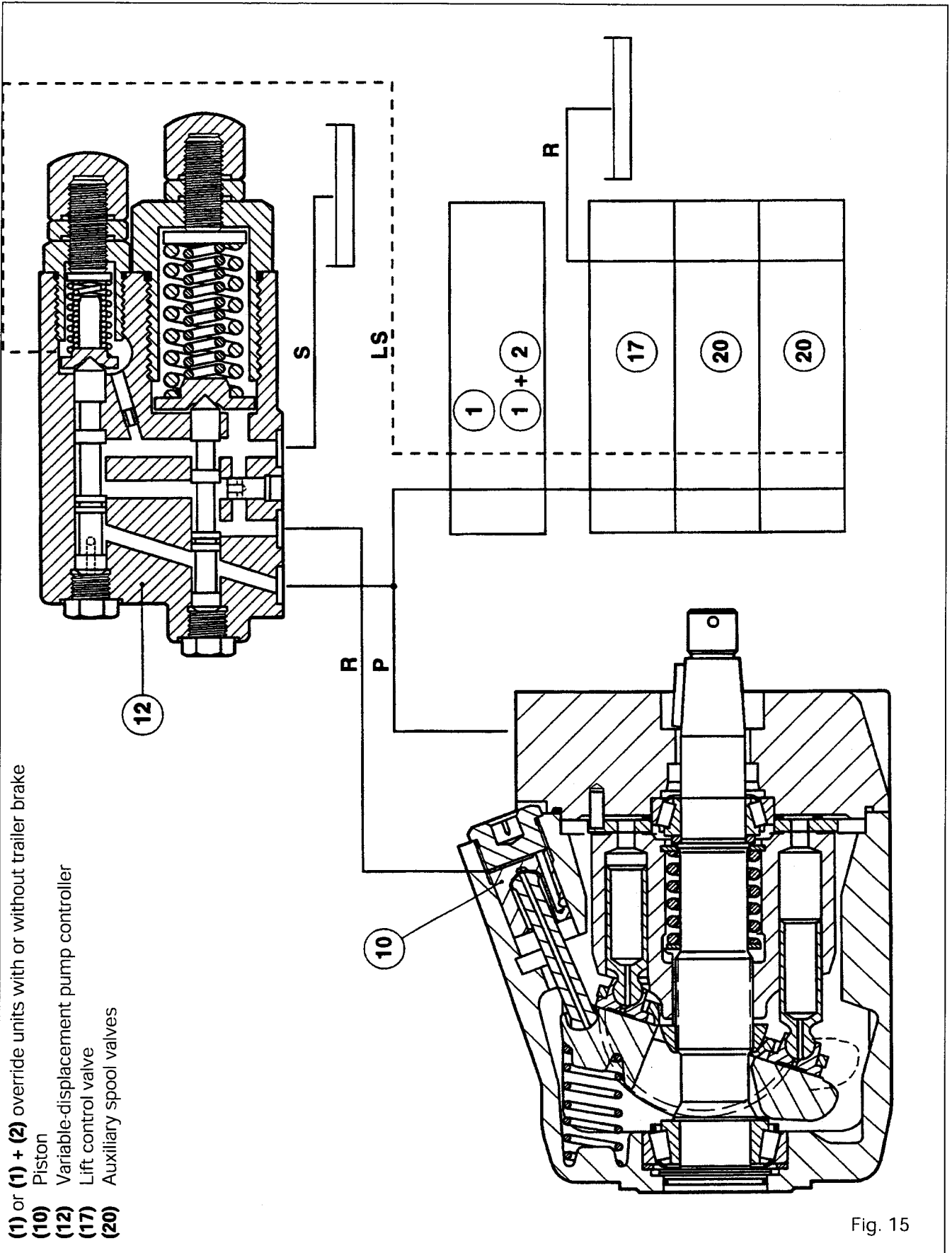

- (1) or (1) + (2) override units with or without trailer brake
- (10) Piston
- (12) Variable-displacement pump controller
- (17) Lift control valve
- (20) Auxiliary spool valves

Fig. 15



## Hydraulics - Closed centre

9T01.13

### Work position - full capacity

When a high-pressure, high-flow function is actuated, such as an auxiliary spool valve, the pump switches from the stand-by position to maximum flow. The flow in the spool valve is not sufficiently braked to allow the pump pressure to compress the 22-bar spring of spool **a**. The pump remains in the maximum flow position. The **LS** pilot pressure is slightly higher than the pump pressure minus 22 bars.

### Work position - partial capacity

When a spool valve is partially opened, this causes a pressure increase which generates an **LS** pilot pressure that is transmitted to the pump. This pressure pushes the spool **a**, allowing the pump to be set to full capacity. The pump pressure increases and pushes the spool **a** back to its balance position where the pump pressure is 22 bars higher than the **LS** pilot signal.

If the load on the receiver increases, the **LS** pilot pressure increases on the spring side of spool **a** and communication is established between ports **R** and **S**. The pressure on the piston (**10**) decreases, the spring (**8**) pushes back the plate (**6**) and increases the pump flowrate so as to stabilise in a position where spool **a** is in the balance position.

If a higher flowrate is required, the spool valve should be opened more. The pressure drops and the pump flowrate increases to reach another balance level.

### Maximum pressure - zero flow

When the pressure at port **P** reaches 200 bar, spool **b** is pushed forwards, so compressing its spring. Communication is established between ports **P** and **R**, and the piston (**10**) is returned to the zero flow position. The controller (**12**) (Fig. 16), installed on the cover (**8**) regulates the pump flowrate and pressure according to the data transmitted by the **LS** signal.

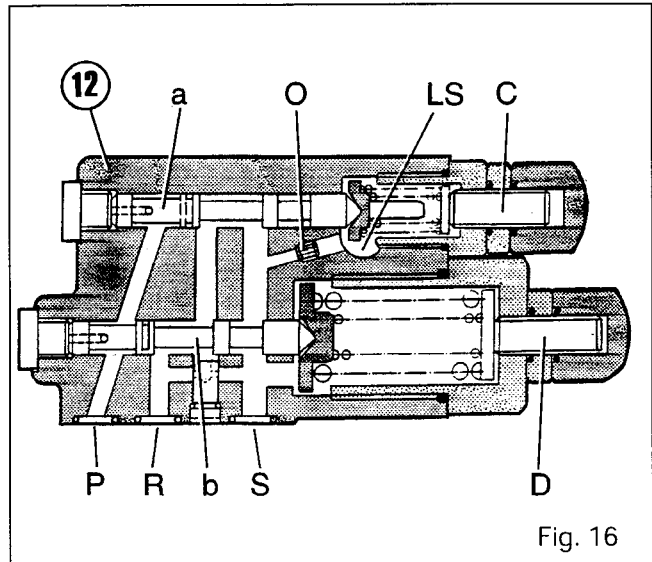

Fig. 16

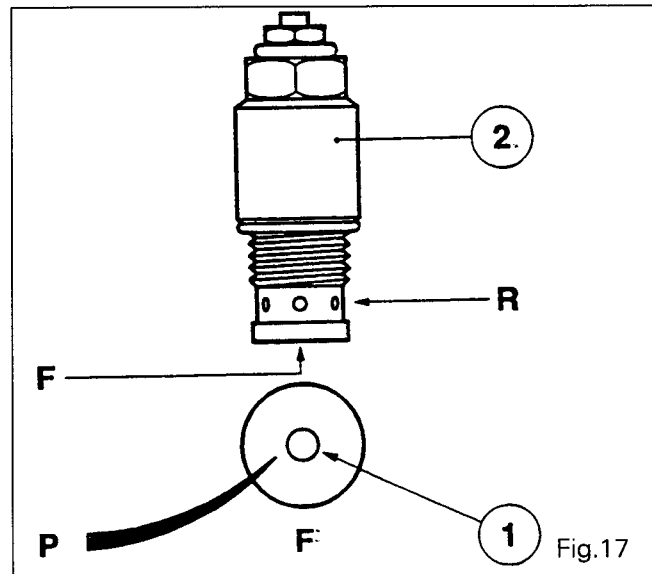

Fig.17

### Identification of channels (Fig. 16)

- C** : 22-bar adjusting screw
- D** : 200-bar adjusting screw
- O** : Decompression port
- P** : Pump pressure
- R** : To piston (**10**)
- S** : Return
- LS** : Signal

**Important : Adjusting screws C and D are pre-set. These settings should not be modified.**

### Pressure relief valve (2) (Fig. 17)

The high-pressure flow discharged by the variable-displacement pump passes into channel **P** on the cover (**8**) (Fig. 6) and is routed to the override unit or the trailer brake unit (if fitted).

The pressure relief valve calibrated to 230 bar and screwed onto the cover ensures the safety of the high-pressure circuit. If the pressure becomes abnormally high, the valve plug (**1**) is raised and the fluid is routed to the housing via ports **R** in the relief valve.



9T01.14

## 6100 SERIES TRACTORS

**Hydraulics - Closed centre****C . Removing and refitting the pump****Preliminary operations**

22. Remove the right-hand cover. See part A.

**Removal**

23. Remove the pump (41) with the gear (39).  
 24. Unscrew the nut (37). Remove the washer (38).  
 Remove the gear with a suitable extracting tool.  
 Recover the key (40).

**Refitting**

25. Clean the parts and replace any that are faulty.  
 Check that the channels in the cover are not blocked.  
 26. Check that the locating dowels (4) are in place (Fig. 18).  
 27. Replace the O-rings (1) to (3) (Fig. 18).  
 28. Carry out the operations for removal in the reverse order. Tighten the bolts and nuts to the torque values specified at the end of this part.

**Note :** *Apply a small bead of Loctite 574 or equivalent around the bolt holes (47) inside the cover. Use the same method as for the left-hand cover (see Section 9T02, part B).*

**Final operation**

29. Reinstall the right-hand cover (see part A).

**Special point**

- Engine speed sensor (25) : smear the threads with Loctite 577 or equivalent (see the adjusting method in procedure 30).

**Tightening torques**

- Nut (37) : 50 to 60 Nm, Loctite 241
- Bolt (47) : 120 to 160 Nm, Loctite 241
- Bolt (4) : 25 to 35 Nm, Loctite 542
- Locknut : 10 to 15 Nm

**Adjusting method for the engine speed sensor (25)**

30. Screw the sensor fully home without forcing it.  
 Loosen by three-quarters of a turn so as to obtain a clearance of approximately 1 mm between the sensor and the gear (39).  
 Tighten the sensor nut to between 10 and 15 Nm.

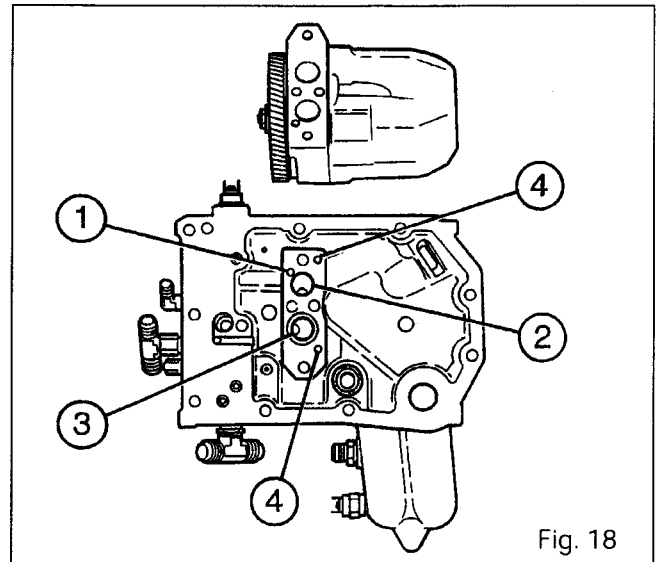

Fig. 18



**Hydraulics - Closed centre**

9T02.1

9 T02 *Left-hand cover*

CONTENTS

- <b>General</b> _____	2
<b>A. Removing and refitting the cover</b> _____	7
<b>B. Removing and refitting the booster pump</b> _____	8
<b>C. Replacing pump seals</b> _____	8





9T02.2

## Hydraulics - Closed centre

### General

The left-hand cover installed on the centre housing supports the following components :

**On its inside face:**

- booster pump **(2)** and its driving gear **(12)**
- suction manifold **(4)**

**On its outside face:**

- suction strainer, 150 micrometres **(6)**
- plug **(8)** allowing access to the handbrake adjustment

### Description (Fig. 2)

Oil is sucked in at the rear end of the centre housing via pipe **(1)** and manifold **(4)**. It is then conveyed to the strainer **(6)** and booster pump **(2)** via a channel inside the cover. The oil is then discharged to the variable displacement pump **(41)** via the booster pipe **(3)**.

### List of parts

- (1)** Suction pipe
- (2)** Booster pump
- (3)** Booster pipe
- (4)** Suction manifold
- (5)** O-ring
- (6)** Strainer
- (7)** Bolt
- (8)** Plug
- (9)** Seal
- (10)** Bolt
- (11)** Washer
- (12)** Gear
- (13)** Key
- (14)** Cover
- (15)** Nut
- (16)** Locating dowels
- (17)** O-ring
- (18)** Gasket
- (19)** Bolt
- (20)** Bowl
- (21)** O-ring
- (22)** Bolt
- (23)** O-ring
- (24)** Locating pins



Hydraulics - Closed centre

9T02.3

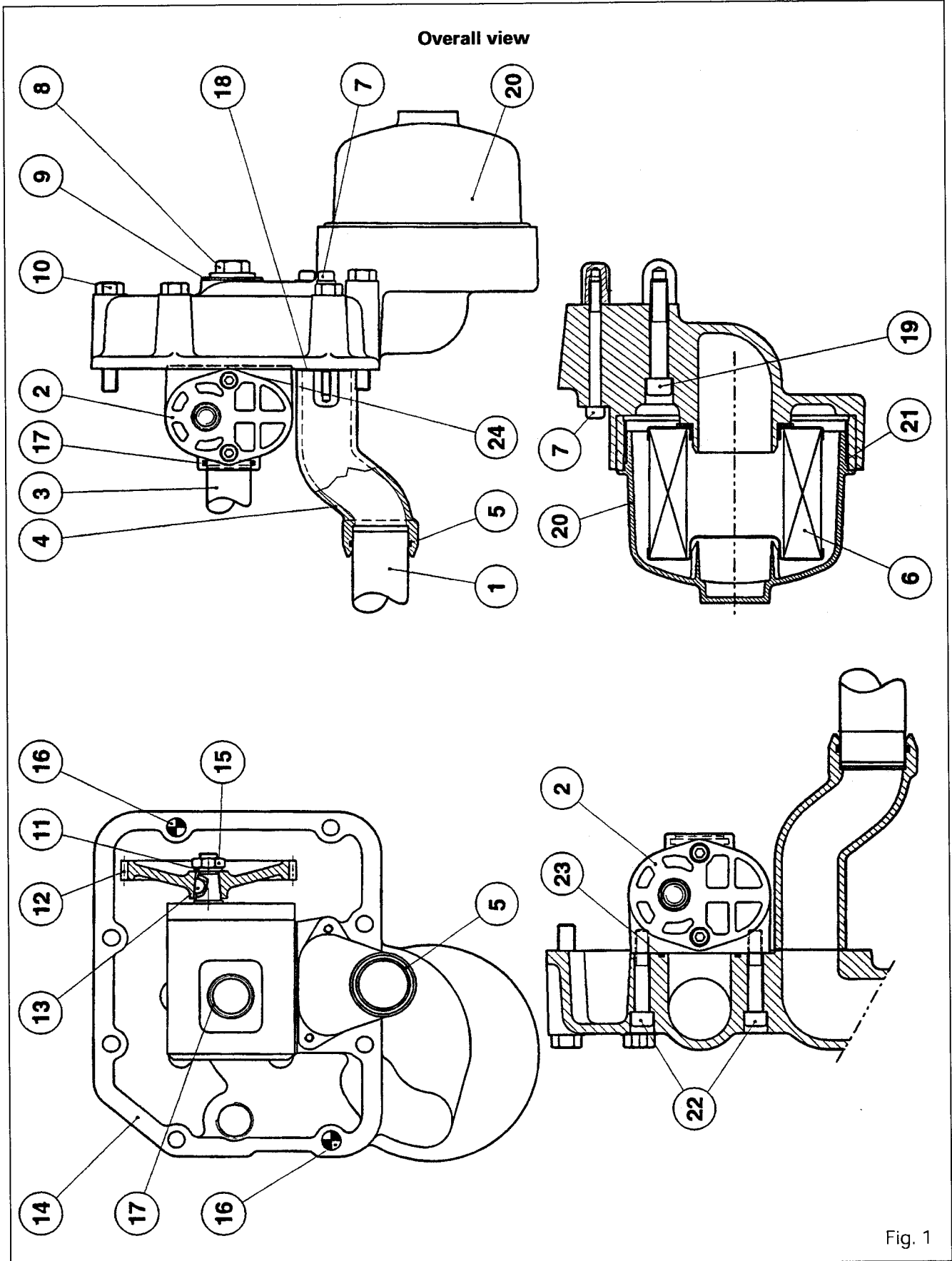

Fig. 1



9T02.4

6100 SERIES TRACTORS



**Hydraulics** - Closed centre

Overall view

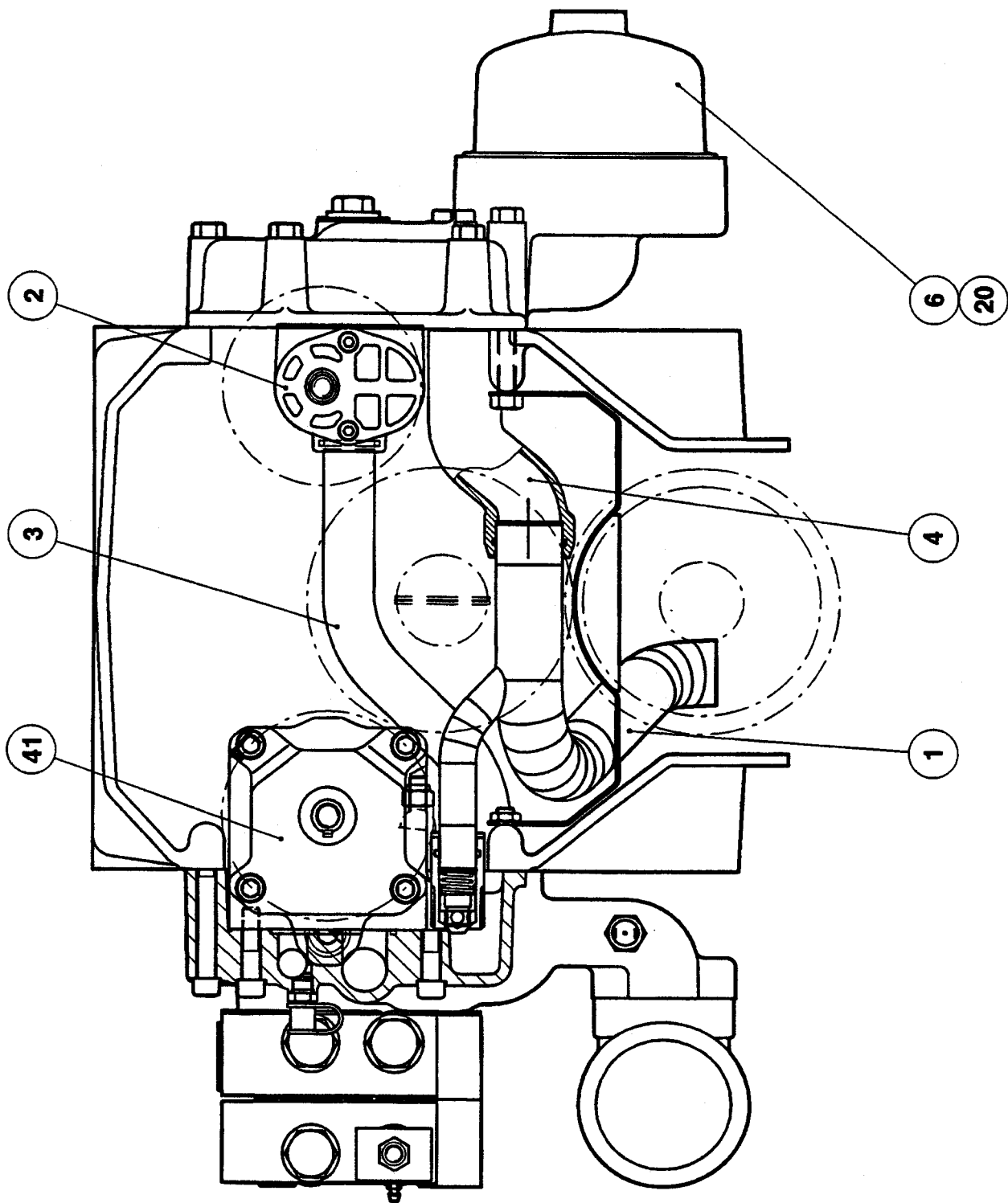

Fig. 2



**Hydraulics - Closed centre**

9T02.5

Exploded view

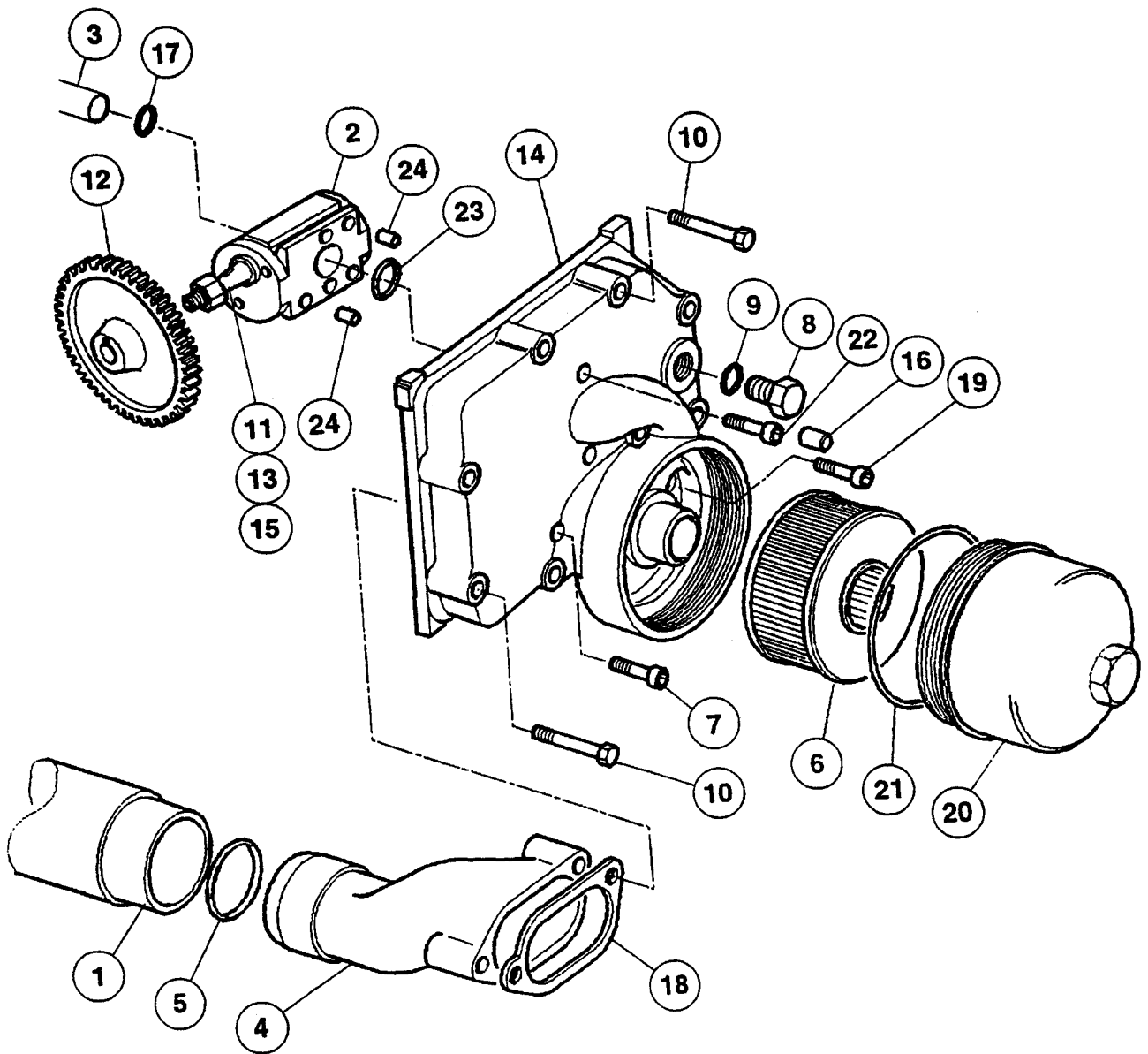

Fig. 3



9T02.6

6100 SERIES TRACTORS



Hydraulics - Closed centre

Identification of ports and channels

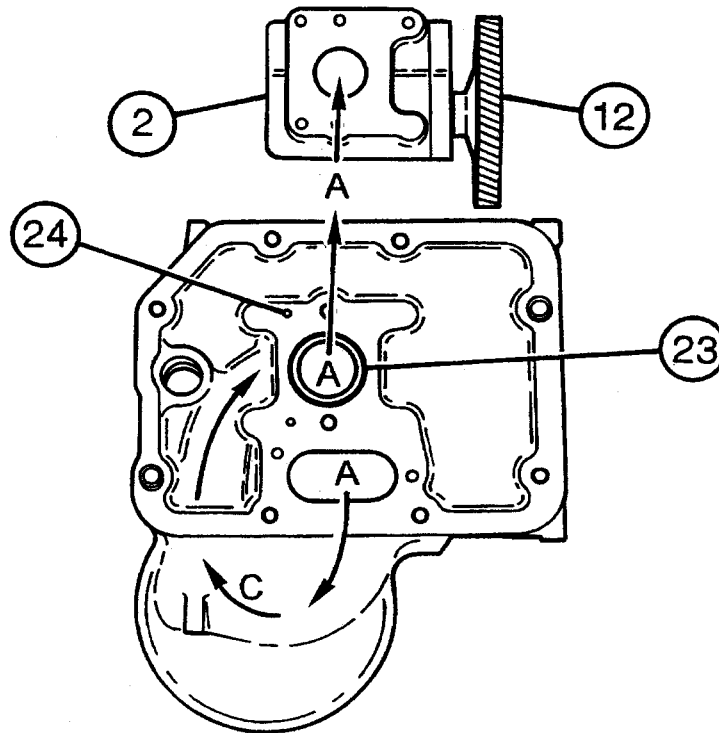
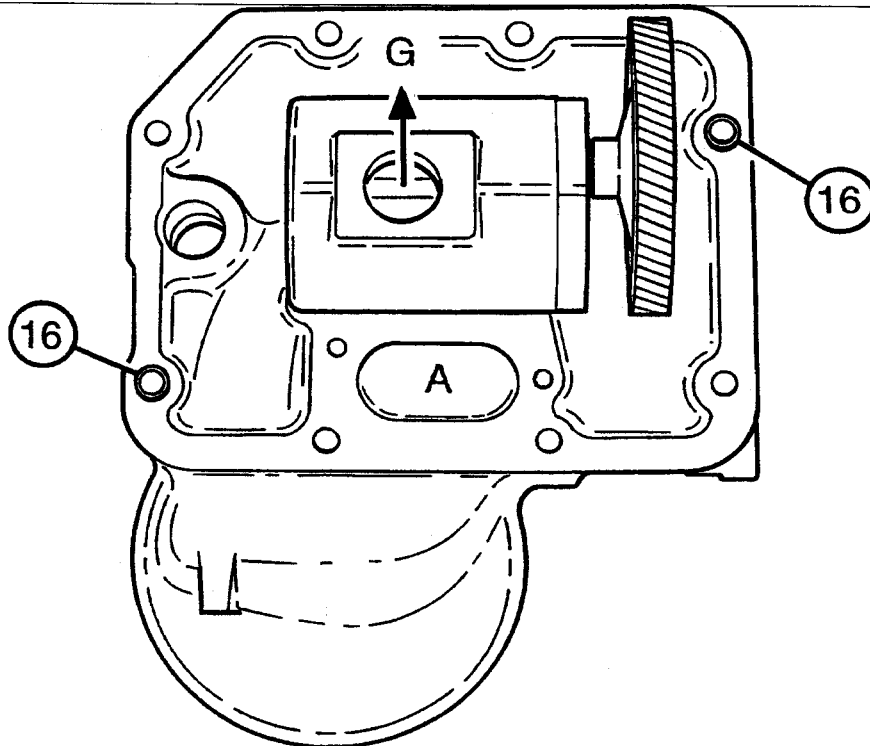

Fig. 4



- A : Suction from pipe (1) and manifold (4)
- C : Strainer (150 micrometres)
- G : Booster feed to variable-displacement pump (41)

Fig. 5



## Hydraulics - Closed centre

9T02.7

### A . Removing and refitting the cover

#### Removal

1. Remove the wheel on the relevant side. Install a stand.
2. Partially drain the oil from the centre housing.
3. Unscrew the bowl **(20)**. Remove the strainer **(6)**.
4. Remove the supports for the handbrake controls and proportional PTO on forward motion (if fitted). Remove bolts **(7)**, **(10)** and **(19)** (Fig. 6).
5. Remove the cover **(14)** and the suction manifold **(4)**.

#### Refitting

6. Clean the mating face between the housing and the cover. Apply Loctite 510 or equivalent on the housing mating face.
7. Replace the O-ring **(17)** and position the seal **(5)** on the suction manifold **(4)** (Fig. 1).
8. Reinstall the manifold on the pipe **(1)**.
9. Slide the gasket **(18)** on the guide dowels **G2**, with the face on the manifold side lightly smeared with silicone (Silicom type). Screw the two diametrically opposite guide dowels **G1** on the housing (Fig. 7).
10. Check that the two locating dowels **(16)** are in place (Fig. 5).
11. Slide the cover onto the guide dowels **G1** and **G2** and fit it on the housing.
12. Remove the guide dowels **G2** alternately and fit bolts **(7)** smeared with Loctite 241 and tighten to a torque of 15 to 20 Nm.
13. Remove the guide dowels **G1**. Reinstall the supports. Fit bolts **(10)** and **(19)** and tighten them to a torque of 90 to 120 Nm.
14. If necessary, replace the O-ring **(21)** on the bowl **(20)**. Install the strainer **(6)** and tighten the bowl.
15. Carry out procedures 1 and 2 in the reverse order.
16. Check for leaks from the mating face between the cover and the bowl.

#### Tightening torques

- Bolts **(7)** : 15 to 20 Nm (Loctite 241)
- Bolts **(10)** **(19)** : 90 to 120 Nm
- Wheel nuts : 400 to 450 Nm.
- Bowl **(20)** : moderately tight

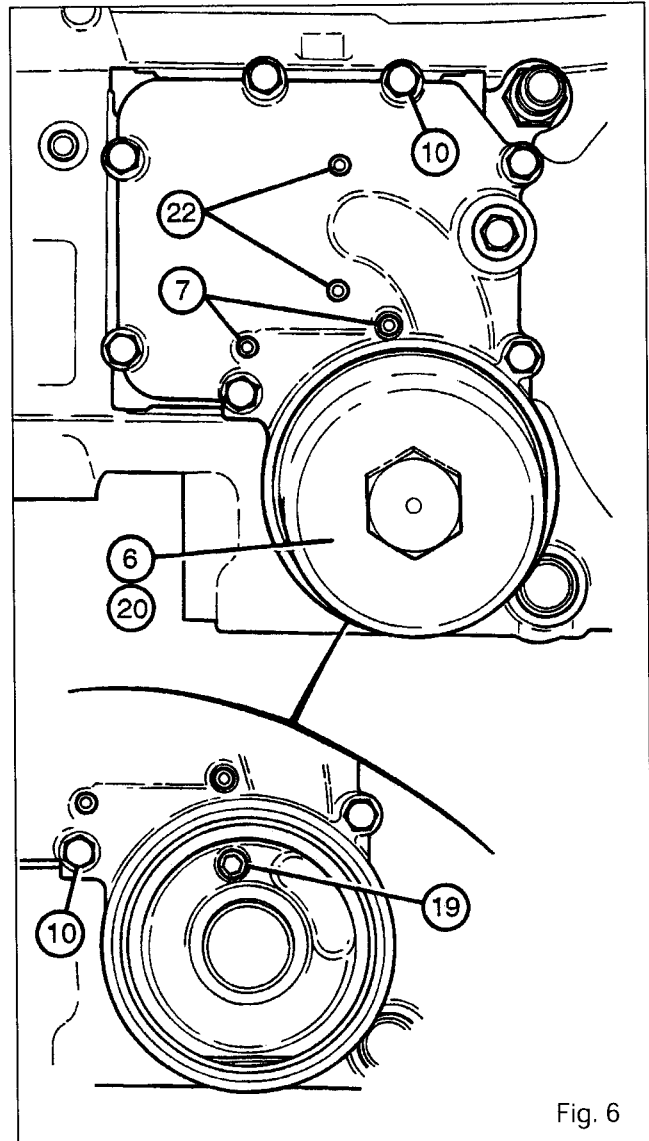

Fig. 6

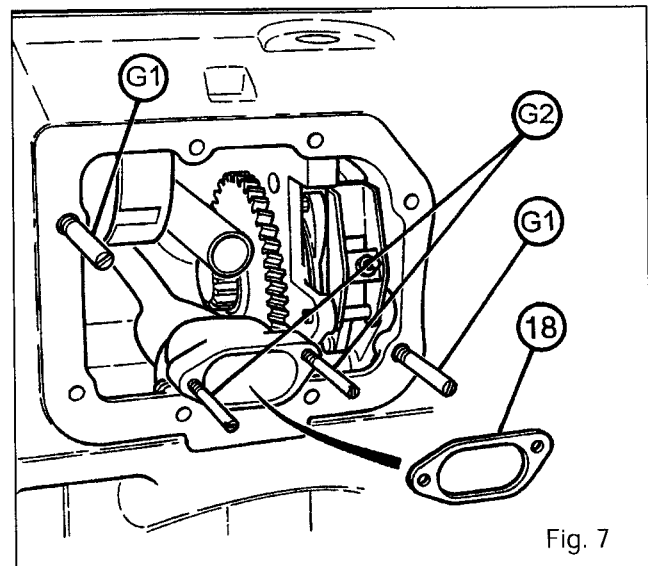

Fig. 7



9T02.8

## 6100 SERIES TRACTORS

**Hydraulics - Closed centre****B. Removing and refitting the booster pump****Preliminary operation**

17. Remove the cover (see § A).

**Removal**

18. Remove the bolts (22) and the pump (2) (Fig. 1).

**Note : The gear (12) can be dismantled without removing the pump. Recover the key (13).**

**Refitting**

19. Clean the bearing faces between the pump and the cover.

20. Check that the two locating pins (24) are in place (Fig. 8).

21. Apply a bead C of Loctite 574 or equivalent around the two bolts holes inside the cover (Fig. 8). The diameter of this bead must be small so that it does not reach the groove for seal (23). Fit a new seal.

22. Position the pump on the locating pins.

23. Fit the bolts (22) smeared with Loctite 241 or equivalent and tighten them to a torque of 40 to 50 Nm.

24. Check the rotation of the pump by hand.

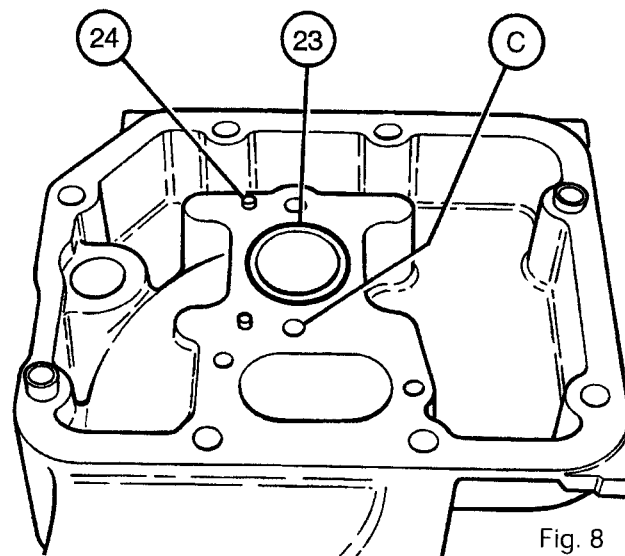

Fig. 8

**Tightening torques**

- Nut (15) : 50 to 60 Nm (Loctite 241)
- Bolt (22) : 40 to 50 Nm (Loctite 241)

**Final operation**

25. Reinstall the cover (see § A).

**C . Replacing the pump seals (Fig. 9)****Preliminary operation**

26. Remove the left-hand cover (see § A) and the booster pump (see § B).

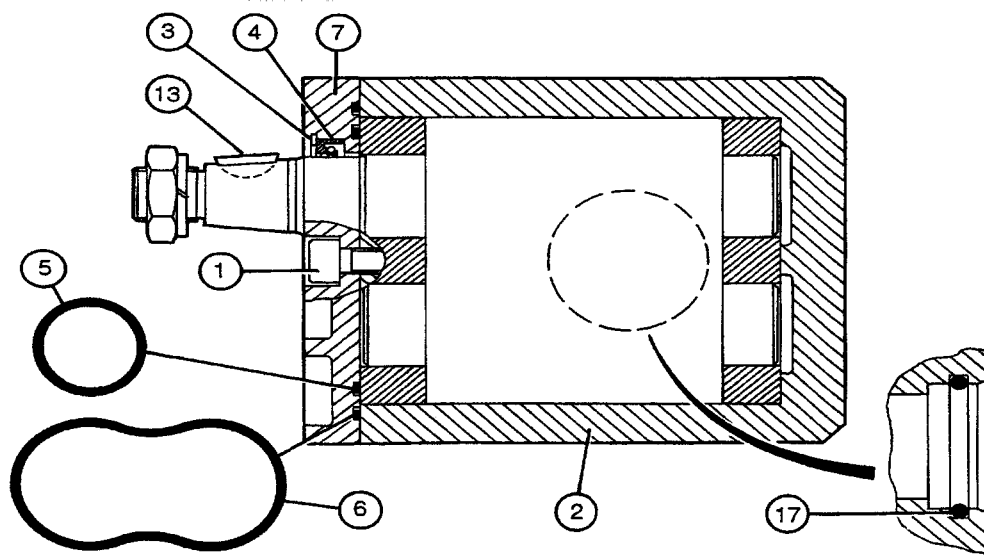

Fig. 9



## Hydraulics - Closed centre

9T02.9

### Removal

27. Clamp the pump in a vice fitted with plastic jaws.
28. Remove the bolts **(1)** and the cover **(7)** (Fig. 10).
29. Remove the circlip **(3)**, the lip seal **(4)** (Fig. 11) and the O-rings **(5)** and **(6)** (Fig. 12).

### Refitting

30. Lubricate the seal **(4)** and fit it using a suitable fixture. Install the circlip **(6)**.
31. Lightly smear the O-rings **(5)** and **(6)** with miscible grease and position them in the cover **(7)** (Fig. 12).
32. Fit the cover (Fig. 13). Fit the bolts **(1)** and tighten them to a torque of 30 to 40 Nm.

### Final operation

34. Reinstall the booster pump (see § B) and the left-hand cover (see § A).

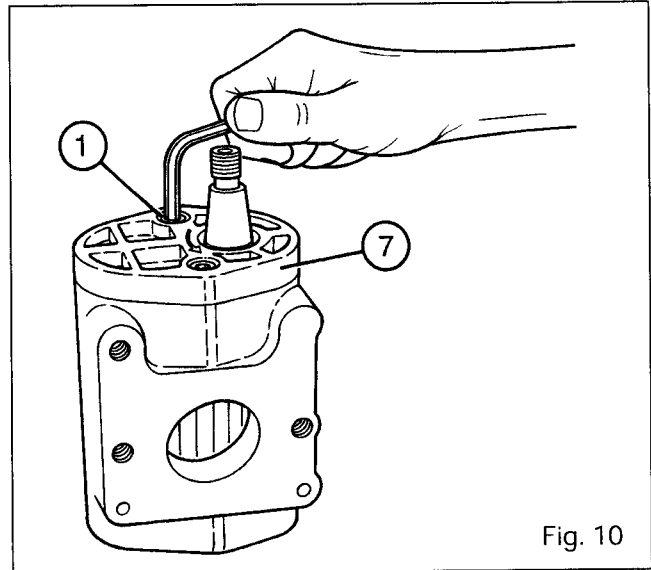

Fig. 10

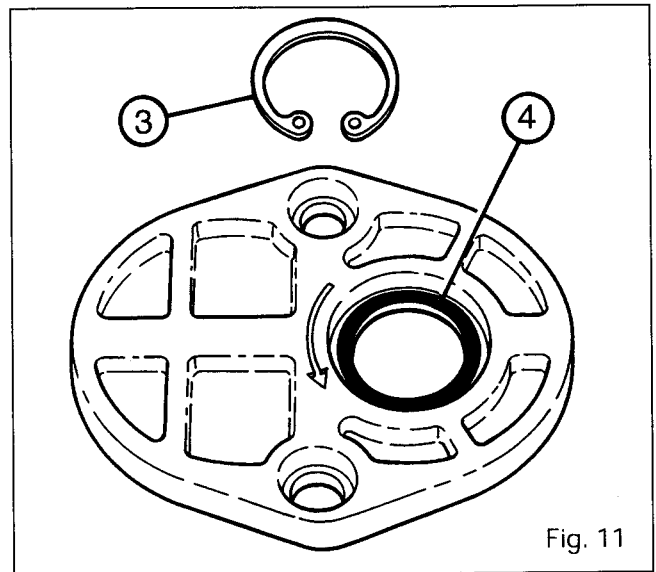

Fig. 11

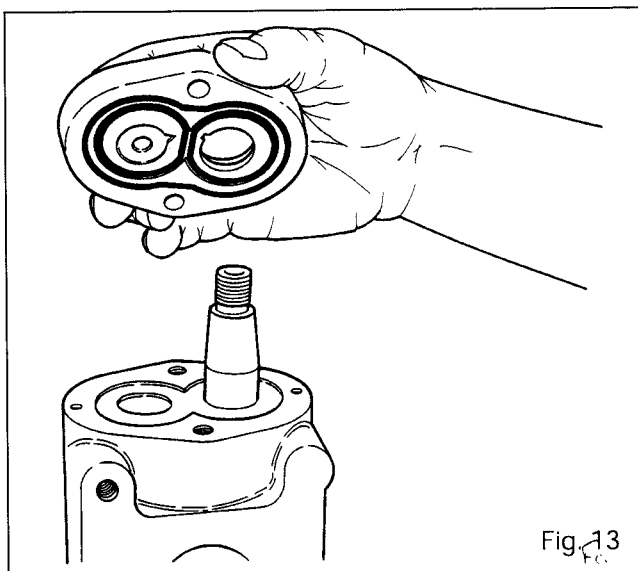

Fig. 13

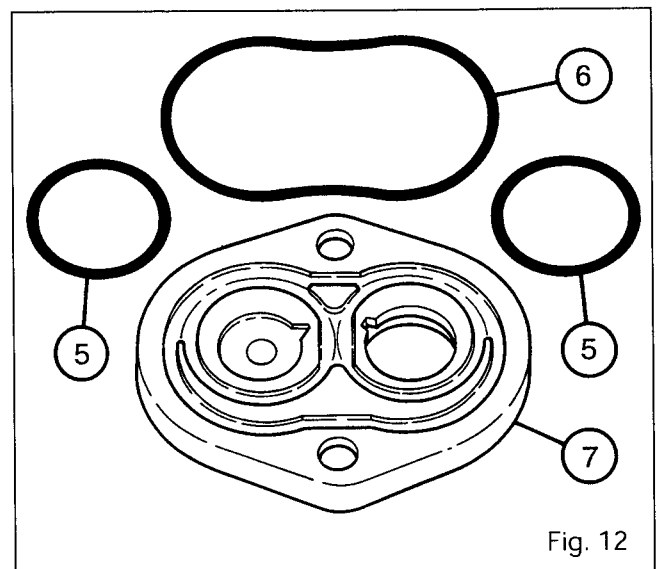

Fig. 12







## **Hydraulics - Closed centre**

### 9 U01 Brake and clutch master cylinders circuit

#### CONTENTS

<b>A. Working on brake and clutch master cylinders</b>	<b>2</b>
<b>B. Master cylinders with trailer brake</b>	<b>3</b>
<b>C. Master cylinder without trailer brake</b>	<b>5</b>
<b>D. Adjusting the brake pedals</b>	<b>6</b>
<b>E. Clutch master cylinder</b>	<b>7</b>
<b>F. Adjusting the clutch pedal</b>	<b>7</b>
<b>G. Bleeding the main brake circuit</b>	<b>8</b>
<b>H. Bleeding the clutch circuit</b>	<b>9</b>



9U01.2

## 6100 SERIES TRACTORS

**Hydraulics - Closed centre****A . Working on brake and clutch master cylinders**

The design of the 17-bar function on 6100 series tractors equipped with a hydraulic system of the closed centre type is different from that on the open centre version. A manifold **(51)** is mounted under the hood in the location of the distribution valve and ensures lubrication of the gearbox, topping up of the brake and clutch master cylinders and return to the housing (Fig. 1).

If it should prove necessary to dismantle the master cylinders, clean all parts carefully. Replace any parts which are scratched or deformed.

Brake and clutch master cylinder repair kits can be found in the spare parts catalogue. After disassembling or replacing brake master cylinders, bleed the main brake circuit and the trailer brake circuit (if fitted). Proceed as described in part G and in Section 9N01, part C. Check the adjustment of the pedals (see part D).

After disassembling or replacing the clutch master cylinder, bleed the circuit (see part H). Check the pedal adjustment (see part F).

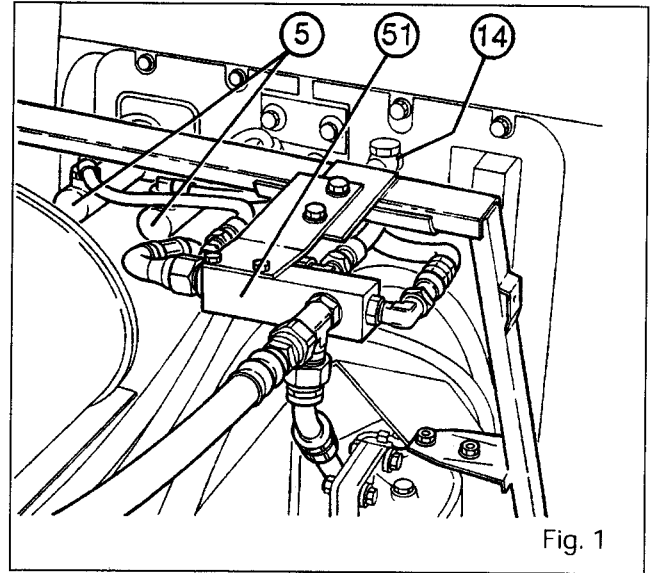

Fig. 1



## Hydraulics - Closed centre

### B. Master cylinder with trailer brake (dual circuit) (Fig. 3)

#### Pedals unlatched (Fig. 2)

The force applied on a pedal, transmitted by rod (7), moves the piston (4) in the bore of the active master cylinder. Valve (1) closes the feed port, the balancing valve (3) is opened by the piston (4) and ball (2) and oil is fed under pressure to the ports of the main brake C and of the pressure balancing junction D.

Through the junction, the pressure closes the valve (3) of the passive master cylinder.

Action on piston (4) also causes the movement of piston (6) and the closing of valve F. The oil contained in chamber E is channelled via the connecting bar to chamber E' and to port B' via the open valve F' in the passive master cylinder.

The assembly comprising valve F and piston (6) quickly reaches the end of the active master cylinder.

In this position, only the tractor brake is actuated, and the trailer is not braked.

#### Pedals latched

#### Braking and pressure balancing

The force applied on both pedals, transmitted by the push rods (7) moves the pistons (4) in the bores of the two master cylinders. The two valves (1) close the feed ports, the two balancing valves (3) are opened by the pistons (4) and balls (2). The pressure is balanced in the two master cylinders by the balancing junction D.

The pressurised oil is also directed to ports C and C' of the main brake circuit.

#### Trailer braking

Continuous action of pistons (4) and (6) closing valves F and F'. Chambers E and E' are pressurised and feed the control system of the trailer brake spool (see Section 9N01) via ports A and A'.

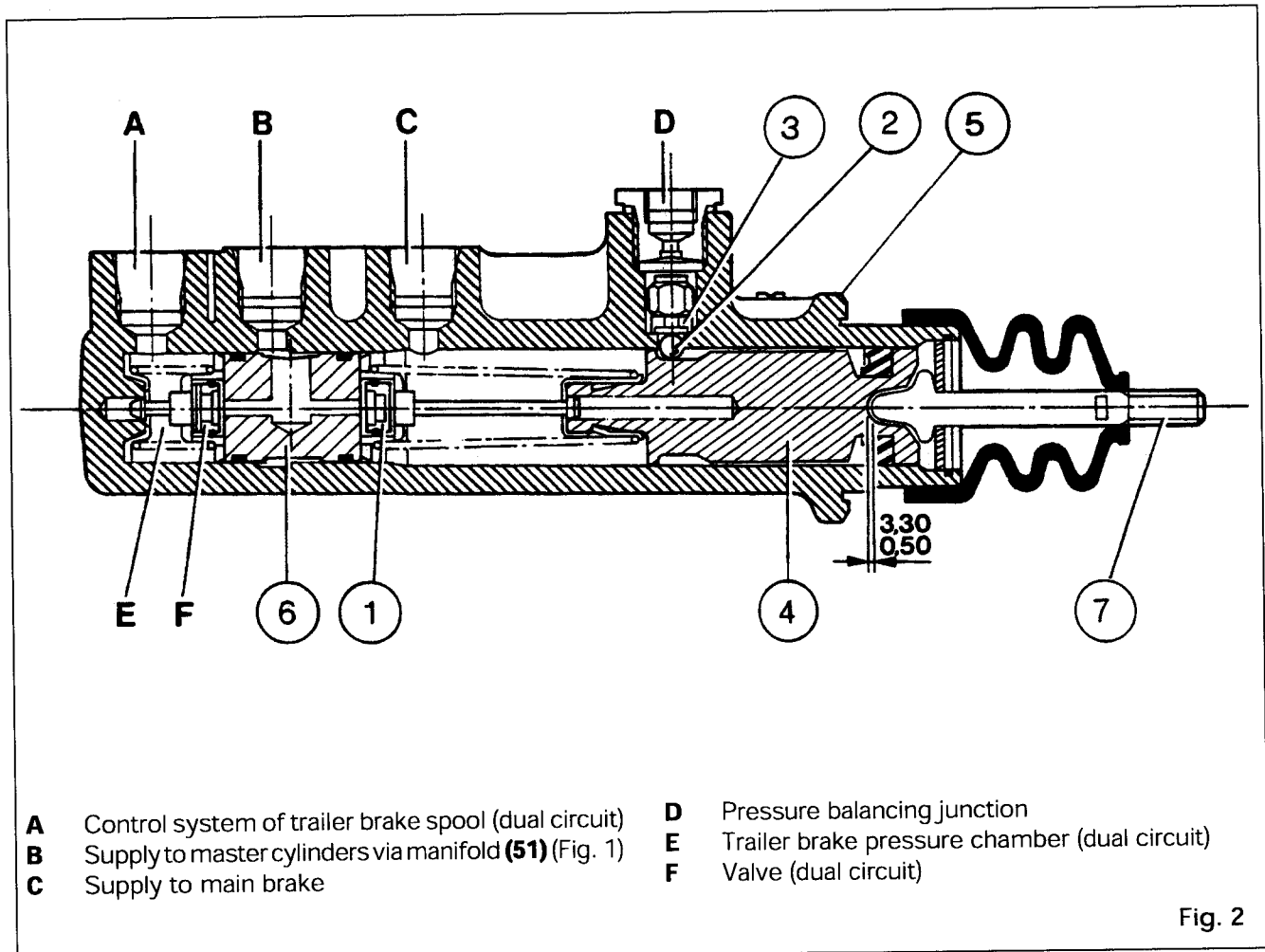



9U01.4

### Hydraulics - Closed centre

**Brake master cylinders with trailer brake (dual circuit)**

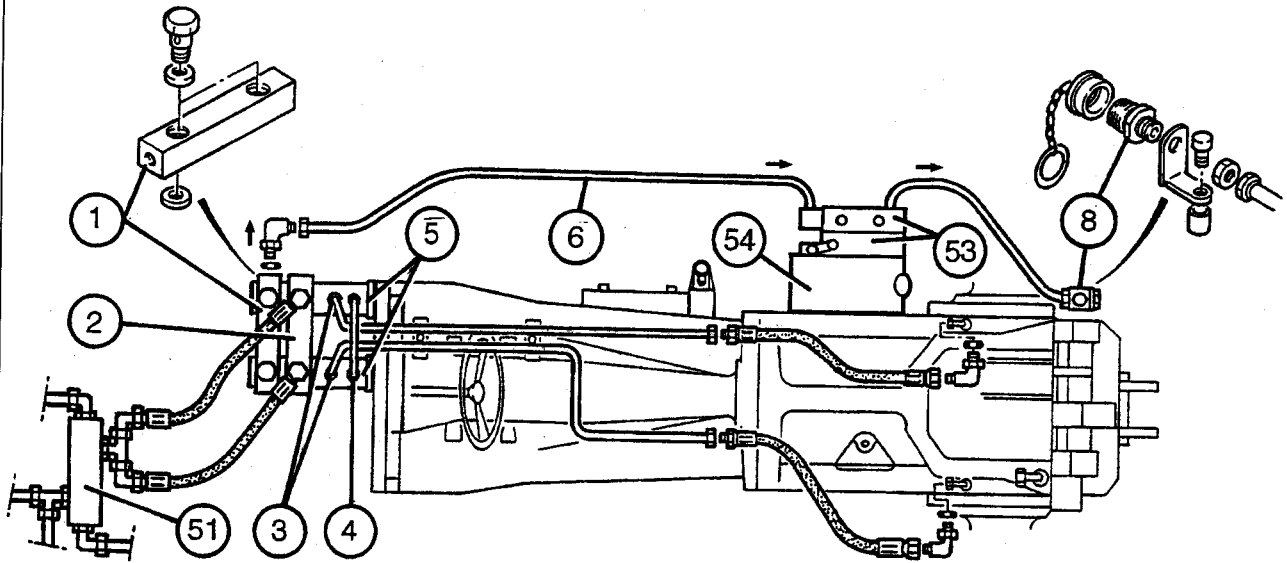

Fig. 3

**Brake master cylinders with trailer brake (single circuit)**

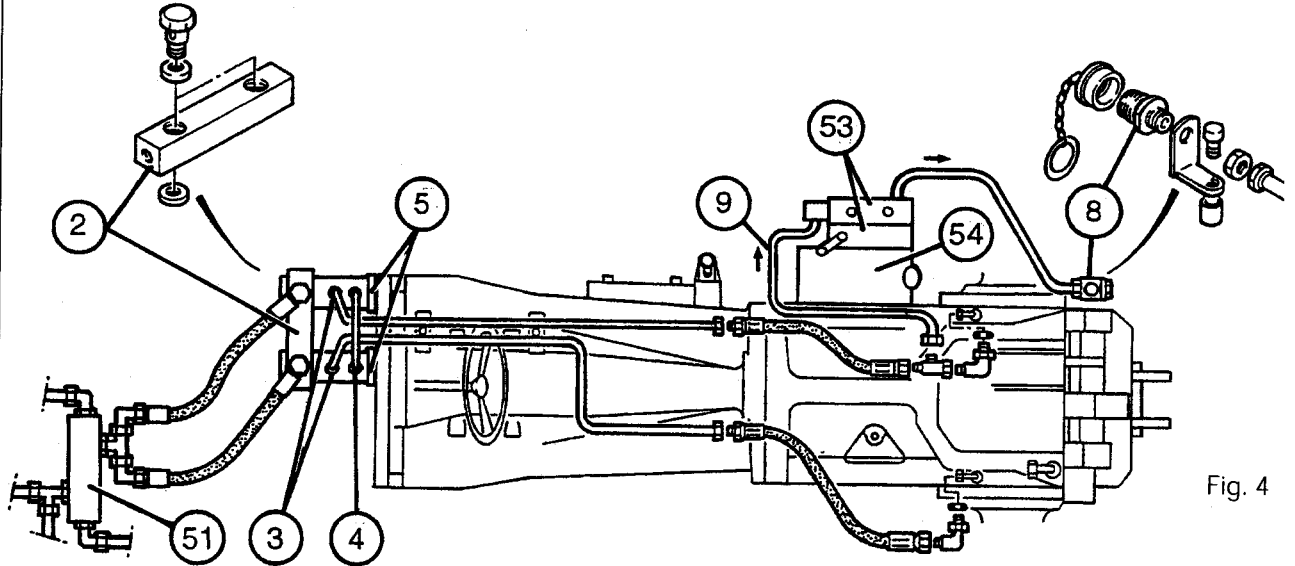

Fig. 4

- (1) Bar (control of trailer brake spool)
- (2) Bar (feed to master cylinders from manifold)
- (3) Feed to main brake
- (4) Pressure balancing junction pipe
- (5) Brake master cylinders
- (6) Trailer brake control pipe
- (8) Trailer brake connector
- (9) Control pipe (single circuit version with trailer brake)
- (51) Manifold
- (53) Trailer brake units
- (54) Right-hand hydraulic cover



## Hydraulics - Closed centre

### C. Master cylinder without trailer brake (single circuit) (Fig. 6)

#### Pedals unlatched (Fig. 5)

The force applied on a pedal, transmitted by rod (7), moves the piston (4) in the bore of the active master cylinder. Valve (1) closes the feed port, the balancing valve (3) is opened by the piston (4) and ball (2) and oil is fed under pressure to the ports of the main brake C and of the pressure balancing junction D. Through the balancing junction, the pressure closes the valve (3) of the passive master cylinder.

#### Pedals latched

#### Braking and pressure balancing

The force applied on both pedals, transmitted by the push rods (7) moves the pistons (4) in the bores of the two master cylinders. The two valves (1) close the feed ports, the two balancing valves (3) are opened by the pistons (4) and balls (2).

The pressure is balanced in the two master cylinders by the balancing junction D.

The pressurised oil is also directed to ports C and C' of the main brake circuit.

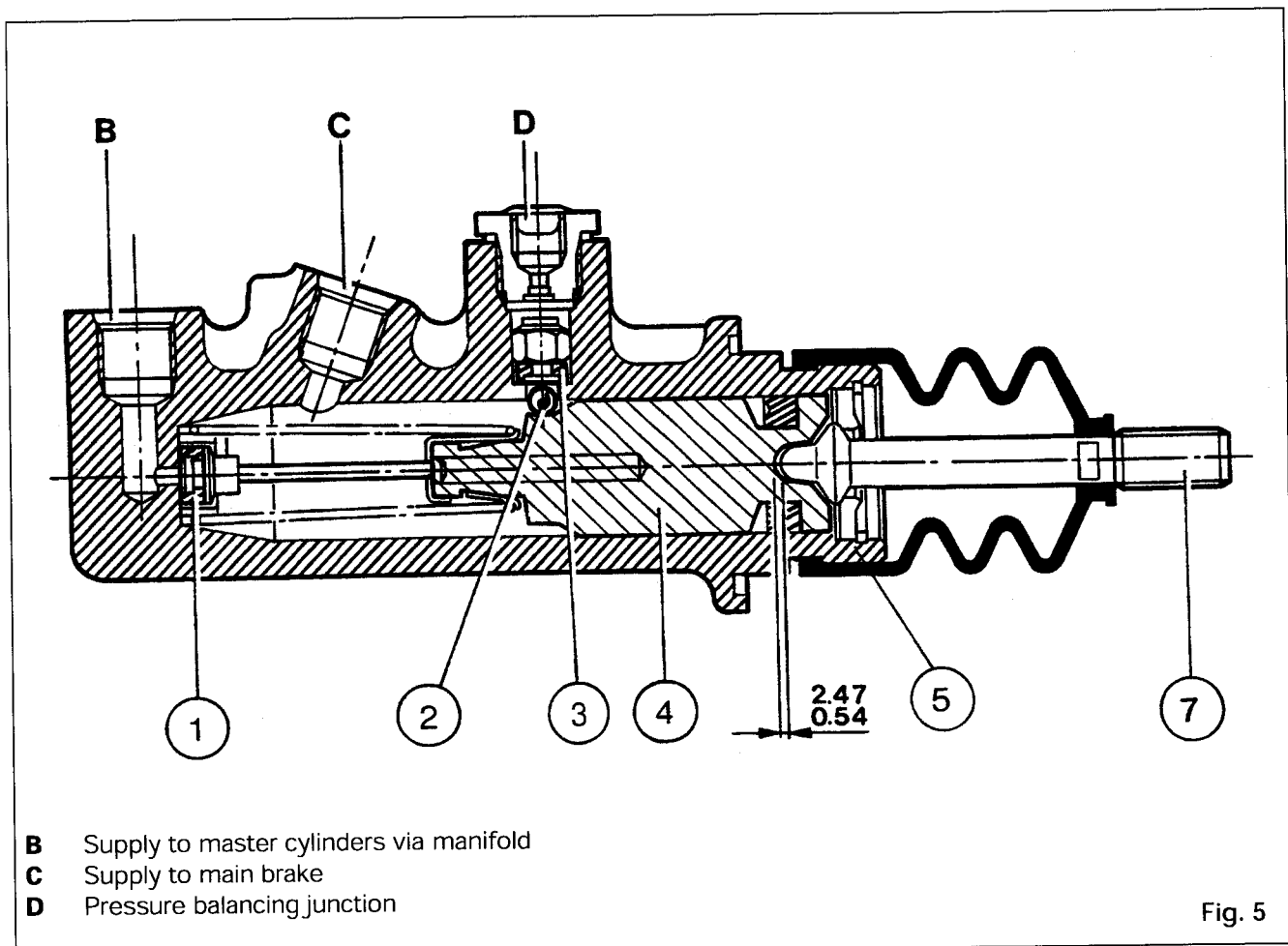



9U01.6

## 6100 SERIES TRACTORS

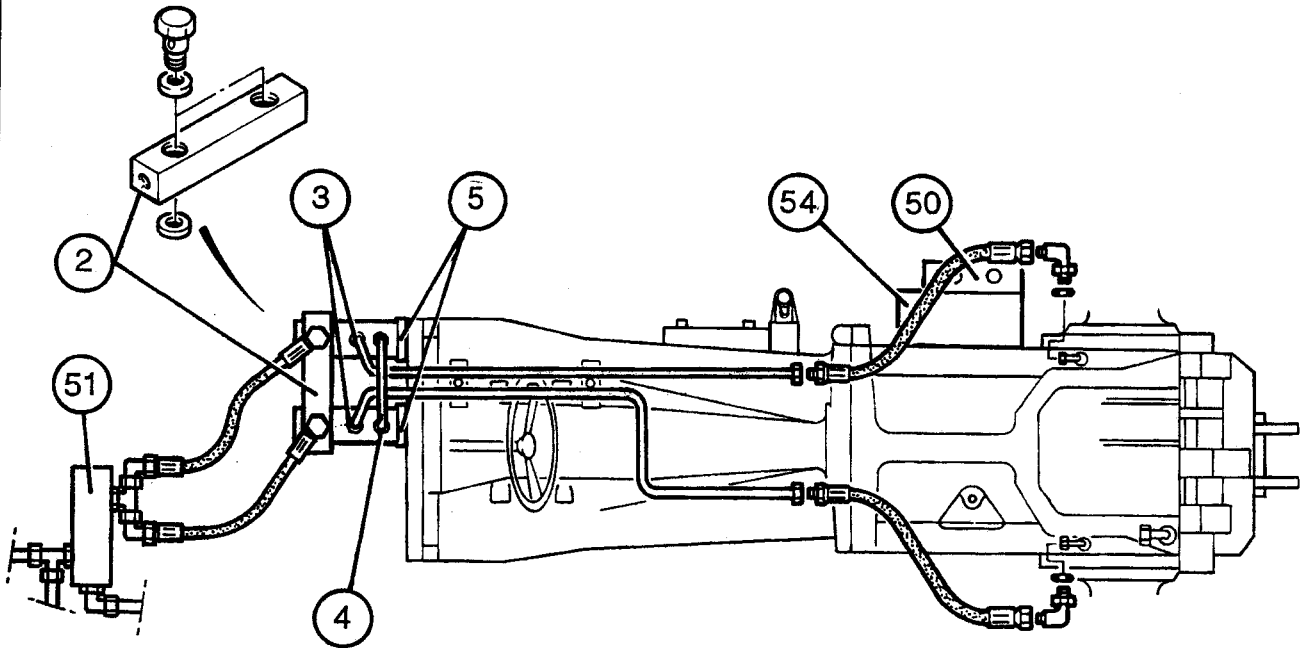
**Hydraulics - Closed centre****Brake master cylinders without trailer brake (single circuit)**

- (2) Bar (feed to master cylinders from manifold)
- (3) Feed to main brake
- (4) Pressure balancing junction pipe
- (5) Brake master cylinders
- (50) Override unit
- (51) Manifold
- (54) Right-hand hydraulic cover

Fig. 6

**D . Adjusting the brake pedals**

1. Coat the pins (5) and (6) with molybdenum bisulphide (Fig. 7).
2. Apply Loctite 542 on the threads on clevis (1) and screw it onto the rod (2).
3. Fit the return spring (3).
4. Adjust the clevis (1) in order to obtain a distance  $X$  of  $115 \text{ mm} \pm 0.5$  between the support (4) and the clevis attaching pin.
5. Proceed in the same manner for the second clevis and check that the twinning mechanism operates smoothly.
6. Manually check the operation of each pedal to ensure that it operates freely.

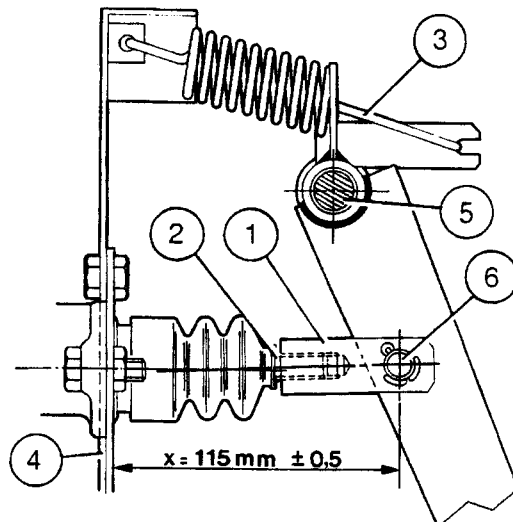

Fig. 7



# Hydraulics - Closed centre

## E. Clutch master cylinder

### Operation (Fig. 10)

The force **F** applied on the pedal moves the piston (1) in the bore of the master cylinder. Oil is fed under pressure to port **B** and the pipe supplying the clutch thrust bearing (spring-loaded clutch) or the clutch control valve (pressure-loaded clutch).

## F. Adjusting the clutch pedal

1. Coat the pins (7) and (8) with molybdenum bisulphide.
2. For spring-loaded clutches (Fig. 9), adjust the stop screw (5) so as to obtain a travel of 215 mm between the disengaged position (with the pedal against the stop (2)) and the engaged position. Tighten the locknut (6).

Then bring the pedal (1) into contact with the stop (5). Adjust the push rod so as to obtain a clearance 0.5 to 1 mm between it and the master cylinder piston. Tighten the locknut (4) to a torque of between 15 and 20 Nm.

On tractors with pressure-loaded clutch (hydraulically operated), the pedal clearance is not adjustable (Fig. 8).

Use the same method as in the previous version to adjust the push-rod (3). Bring the pedal (1) into contact with the fixed stop (9) (Fig. 8).

3. Manually check the operation of the pedal.

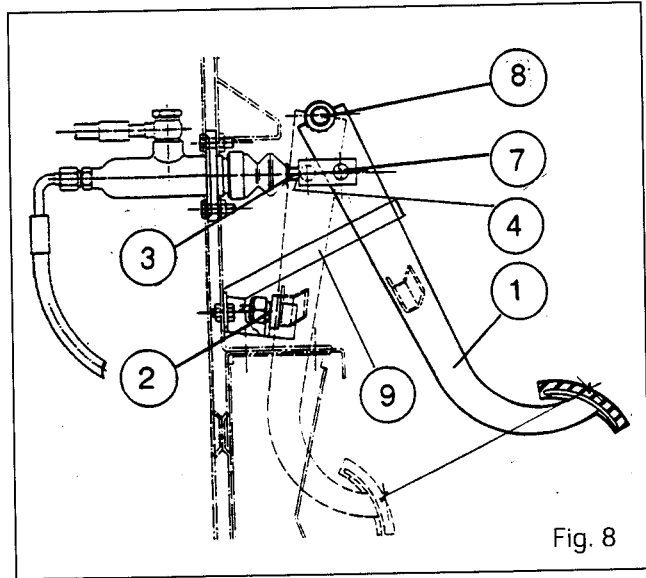

Fig. 8

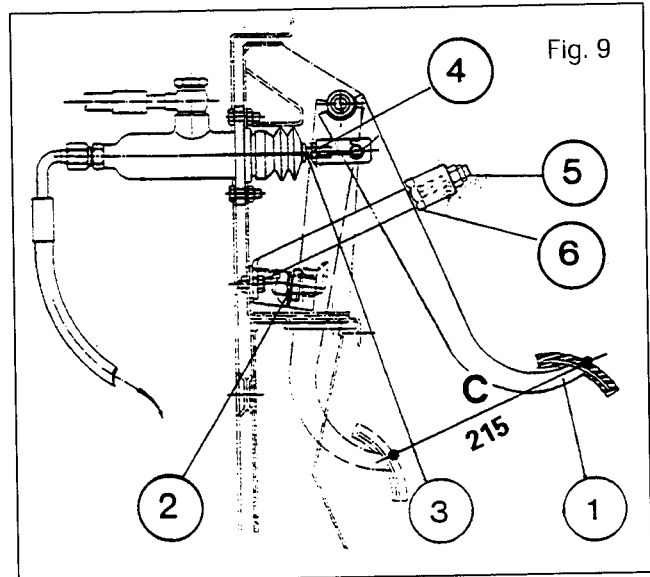

Fig. 9

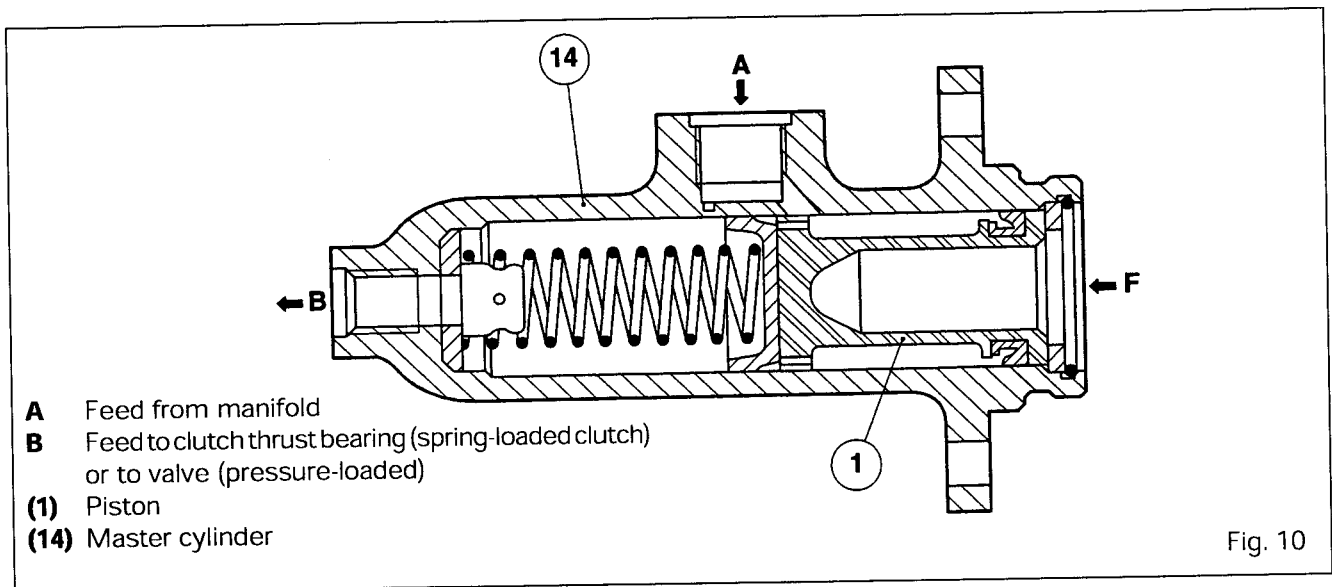

Fig. 10

- A** Feed from manifold
- B** Feed to clutch thrust bearing (spring-loaded clutch) or to valve (pressure-loaded)
- (1)** Piston
- (14)** Master cylinder



**G . Bleeding the main brake circuit**

1. Connect a transparent pipe (with an inside diameter of 6 mm) onto each right-hand and left-hand bleed screw on the axle housing (Fig. 11).
  2. Plunge the end of both pipes into a receptacle partially filled with transmission oil.
  3. Run the engine at approximately 1,200 rpm. Turn the steering wheel several times in order to drive out the air from the steering circuit.
  4. Correctly identify the return hose (1) located to the front left-hand side of the gearbox and block it with a clamp and suitable protection (Fig. 12).
  5. Open the right-hand bleed screw. Check that there are no leaks between the pipe and the bleed screw.
  6. Uncouple the brake pedals.
  7. Press **slowly** on the right-hand pedal until it reaches its end of travel and then release it in the same manner. Repeat this operation several times until the oil flowing out does not contain any air bubbles.
  8. Close the bleed screw.
  9. Open the left-hand bleed screw and carry out the same operations as described above.
  10. Close the bleed screw and remove the clamp from the return hose.
  11. Recouple the brake pedals.
  12. Operate each pedal several times in order to position the brake pistons.
  13. Check the hardness of each pedal when a force is applied.
- Note : If an operating problem occurs, carry out the bleeding procedure a second time.**  
**If the problem persists, check for leaks on :**
- the circuit,
  - the master cylinders,
  - the brake piston seals.
14. Bleed the trailer brake circuit and check the pressure (see Section 9N01, part C).

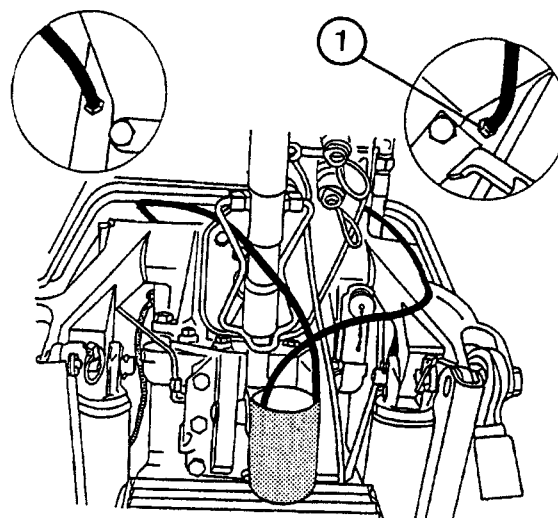

Fig. 11

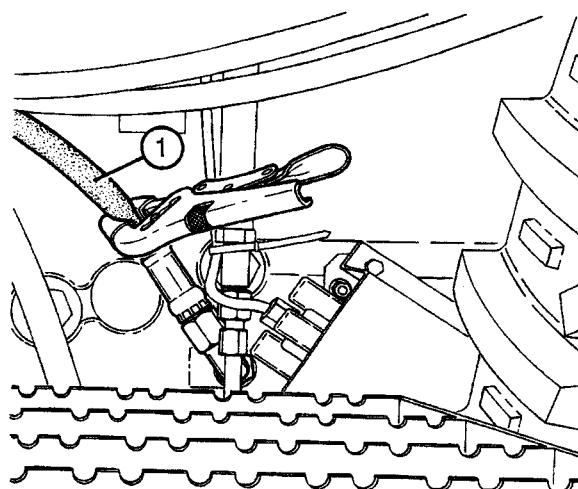

Fig. 12



# Hydraulics - Closed centre

## H. Bleeding the clutch circuit

### Control valve (pressure-loaded clutch) (Fig 13)

1. Run the engine at approximately 1,200 rpm.
2. Using suitable protection, clamp the return hose (1) (see procedure 4 and Fig. 12, part G).
3. Fit a hose onto the bleed screw (2) as shown in Figure 13.
4. Unscrew the bleed screw and **slowly** press the clutch pedal until oil free of bubbles comes out of the hose.
5. Close the bleed screw. Carry out a road test.

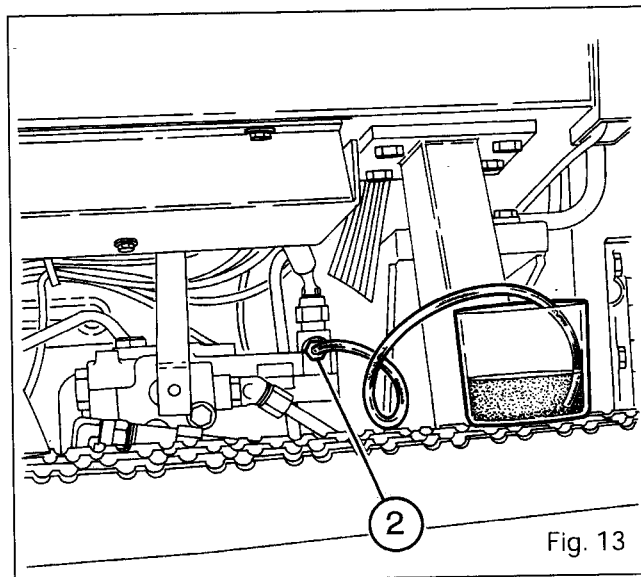

Fig. 13

### Spring-loaded clutch (Fig 14)

1. Use the same method as in the previous version and union No. 3582045M1 fitted with a hose on the bleed connector (67) as shown in Figure 14.

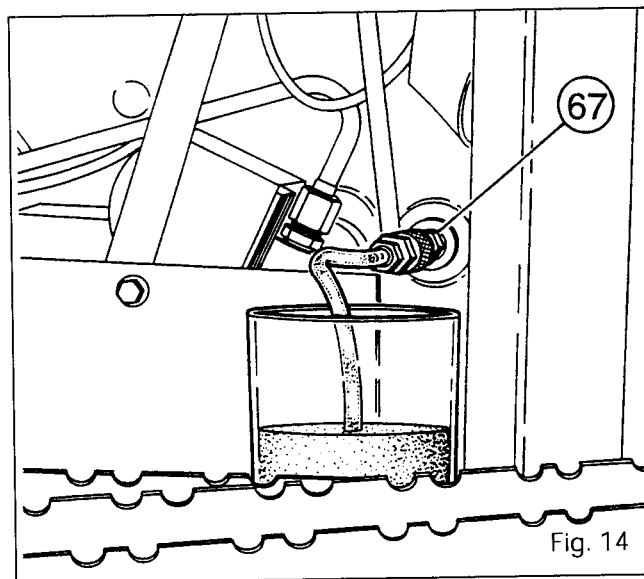

Fig. 14





9 V01 Tests

CONTENTS

- Preparation _____	2
A. Tests on high-pressure circuit _____	2
B. Tests on low-pressure circuit _____	8



9V01.2

## Hydraulics - Closed centre

### Preparation

Before beginning the tests, the engine should be run to bring the oil **temperature** up to a minimum of **80°C** (176°F).

To help increase the oil temperature:

- Run the engine at 2,000 rpm.
- Connect a flowmeter onto an auxiliary spool valve.
- Keep that spool valve actuated.
- Limit the flow in the flowmeter.
- As soon as the oil temperature rises to above 80°C (176°F), release the auxiliary spool valve and open the flowmeter valve.

The following equipment is recommended for the tests described in this section. This equipment is available through the MF network:

- MF 3001: Pressure gauge kit
- MF 3002: Hoses and unions kit
- MF 3004: Flowmeter assembly with turbine
- 3582045M1: Diagnostic coupler

Otherwise, use suitable equivalent equipment.

**In all cases, make sure of the direction of flow of the oil to avoid damaging the flowmeter.**

**Choose pressure gauges, hoses and unions of sufficient capacity and strength.**

Values measured during tests:

- max. flowrate: 105 l/mn,
- min. flowrate: 0 - 5 l/mn,
- max. pressure: 200 bars,
- min. pressure: 0.4 bar.

### A. High-pressure circuit

The high-pressure circuit supplies the following systems:

- the steering,
- the brakes,
- the auxiliary spool valves,
- the lifting system.

#### 1. Booster pressure of the main variable-displacement pump

- Connect a pressure gauge to the diagnostic connector located on the right-hand hydraulic cover (Figures 1 and 3) and check **P1**.

Engine speed rpm	P1 (bar)
1,000	5,2
2,200	6,3

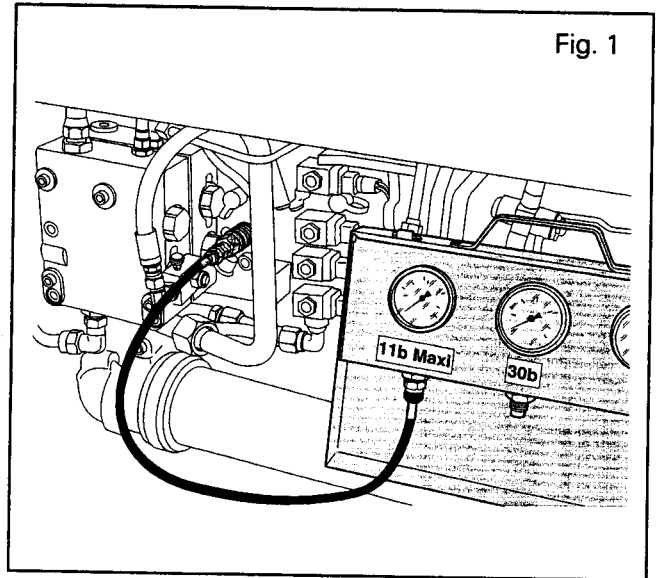

Fig. 1

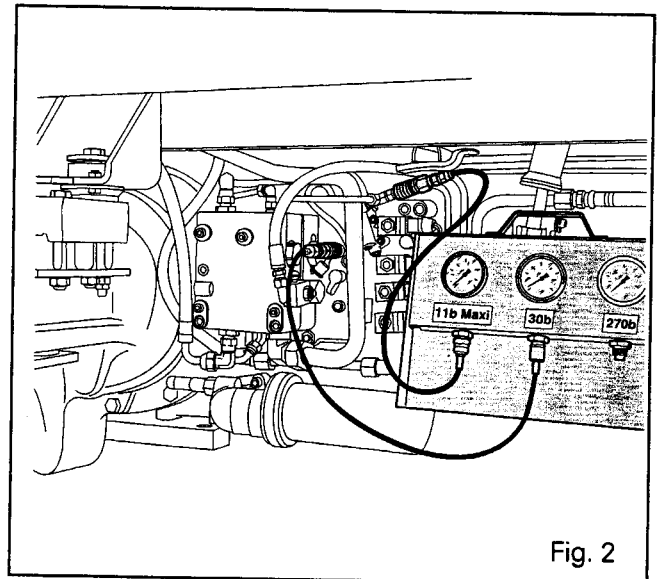

Fig. 2

#### 2. Standby pressure and XLS pressure

Connect a pressure gauge to each diagnostic connector (Figures 2 and 3) located:

- to the pump controller: XLS pressure = **P2**,
- to the right-hand cover: pump pressure = **P3**.

**Important: Do not actuate high-pressure components (such as the steering) as this may damage the pressure gauges connected at P2 or P3.**

Engine speed rpm	P1 (bar)	P3 (bar)
1,000	4	25
2,200	4	25

Pump pressure = XLS pressure + 22 bars ± 1 bar  
**P3 = P2 + 22 bars ± 1 bar**



## Hydraulics - Closed centre

9V01.3

### 3. Maximum flow and pressure

- Connect a flowmeter onto an auxiliary spool valve (Fig. 4) to obtain **Q1**.
- Do not use a valve with automatic return to neutral.
- Connect a pressure gauge to each diagnostic connector located (Figures 5 and 6):
  - . to the pump controller: XLS pressure = **P4**,
  - . to the right-hand cover: pump pressure = **P5**.
- Set the flow controller (1) (Fig. 7) of the auxiliary spool valve to maximum flowrate.
- Actuate the auxiliary spool valve and gradually close the flowmeter valve to reduce the flowrate and increase the pressure.

Engine speed rpm	<b>Q1</b> (l/mn)	<b>P4</b> (bar)	<b>P5</b> (bar)
2,200	90/100	P4 = P5	110
2,200	90/100	- 22 ± 1 bar	130
2,200	90/100		150
2,200	90/100		170
2,200	90/100		180
2,200	0		190

**Note: Do not take the pressure indicated in the flowmeter into account.**

### 4. Adjusting the auxiliary spool valves flowrate controller (1)

- Connect the flowmeter onto a spool valve (Fig. 4) to obtain **Q2**.
- Connect a pressure gauge to each diagnostic connector located (Figures 5 and 6):
  - . under the pump controller: XLS pressure = **P6**,
  - . under the right-hand cover: pump pressure = **P7**.

Controller setting	Engine speed rpm	<b>P6</b> (bar)	<b>P7</b> (bar)	<b>Q2</b> (l/mn) min.
Max.	2,200	106	130	95

Slowly turn the controller (1) (Fig. 7) towards the minimum stop (about 2 turns). **Q2** should drop to a minimum flowrate of between 0 and 5 l/mn. If the flowrate is not correct, see Section 9Q01 for its adjustment.

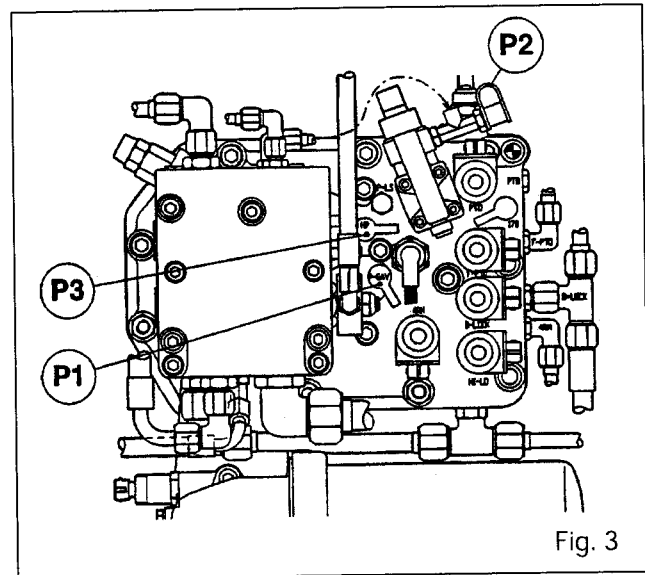

Fig. 3

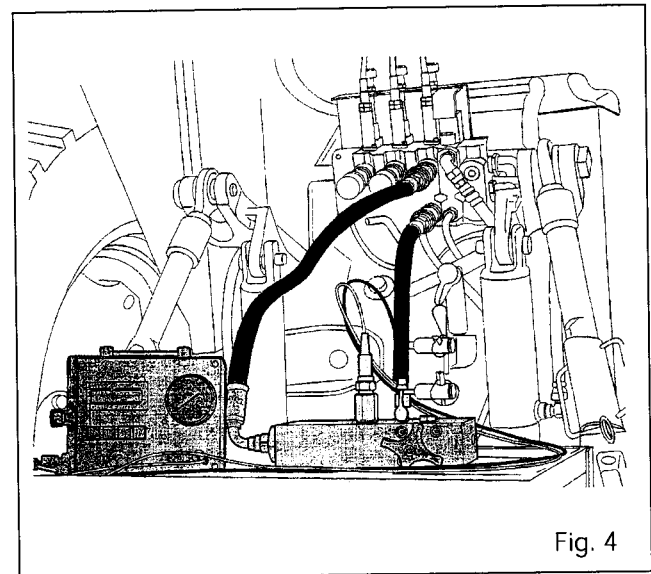

Fig. 4

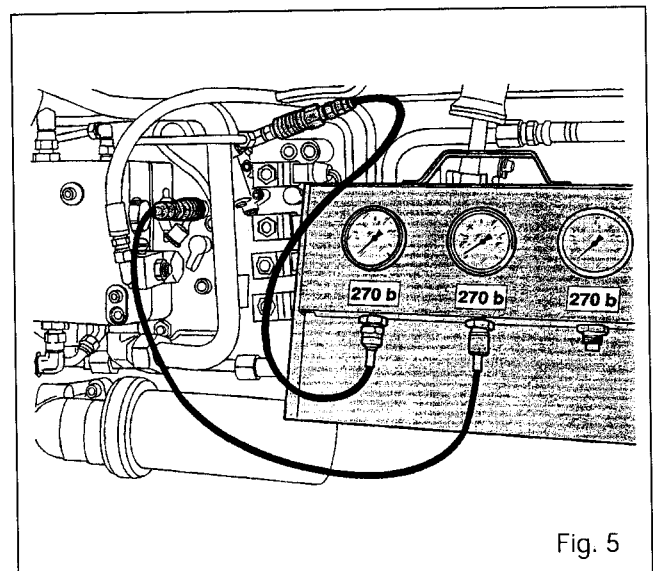

Fig. 5



9V01.4

## Hydraulics - Closed centre

### 5. Auxiliary spool valve with automatic return to neutral (Fig. 4)

- Connect a flowmeter to the valve concerned.
- Connect a pressure gauge to the pump controller (Fig. 6 and 8) and read: XLS pressure = **P8**.
- Run the engine at 1,000 rpm. Set the valve to the automatic return position, release the lever and gradually close the flowmeter valve until the lever returns to the neutral point. Read the triggering pressure:

**P8 = 160 to 175 bars.**

**Note: Check that the valve is in the automatic return position and not in the floating position.**

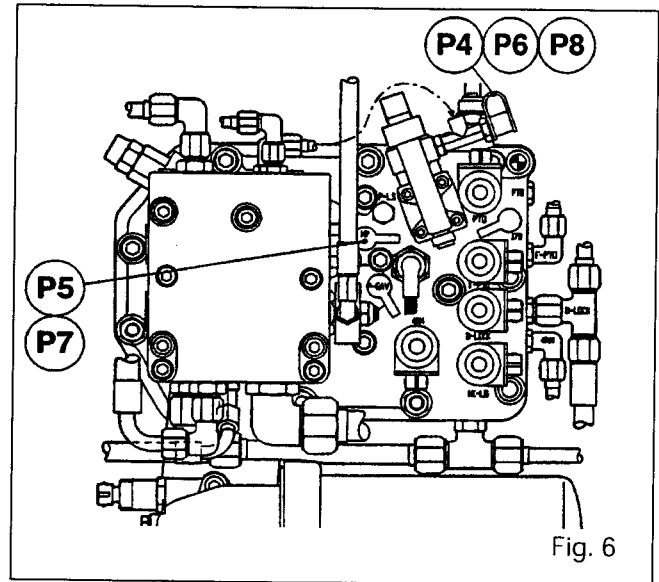

Fig. 6

### 6. Lifting

#### Maximum pressure

- Connect a pressure gauge to each diagnostic connector (Figures 9 and 10) located:
  - on the pump controller: XLS pressure = **P9**,
  - on the right-hand cover: pump pressure = **P10**.
- Run the engine at 1,000 rpm.
- Use the external lift control buttons to engage the maximum high position:

**P9 and P10 = 190**

#### Shock valve

- With the engine stopped, connect a hand-operated calibrating pump to the lift rams (with the rams linked together) (Fig. 10).
- Apply pressure with the calibrating pump.

**P11 = 220 to 240 bars**

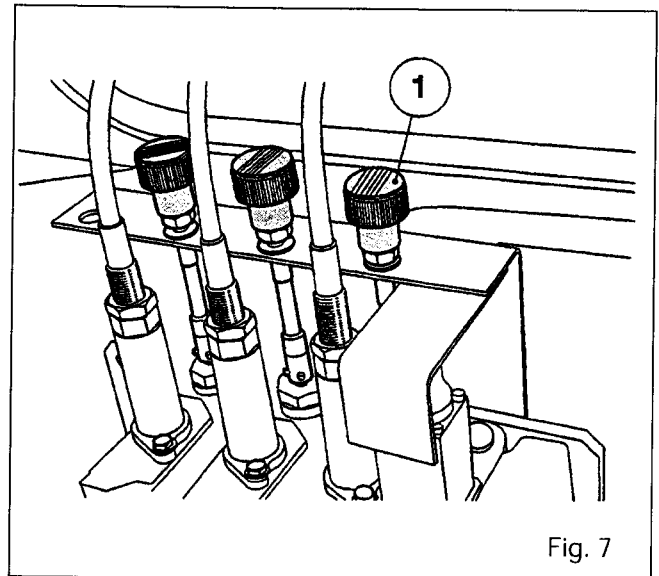

Fig. 7

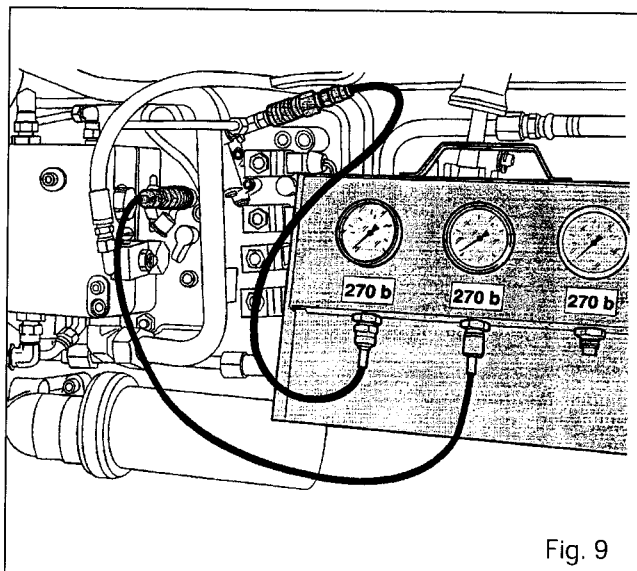

Fig. 9

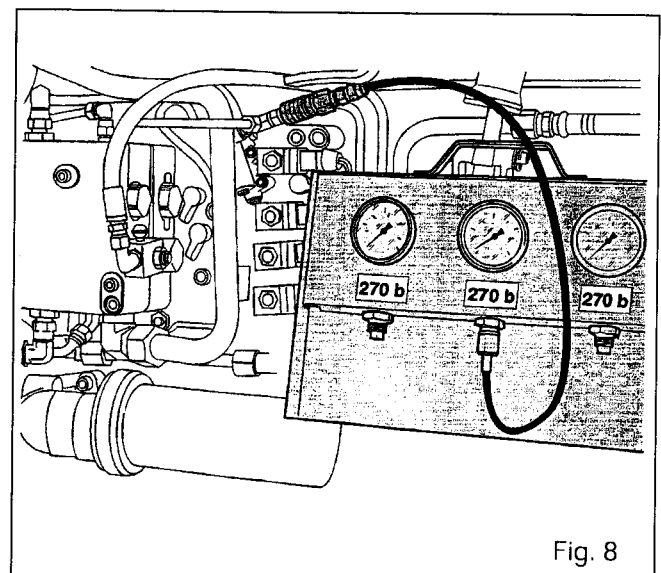

Fig. 8



6100 SERIES TRACTORS

**Hydraulics - Closed centre**



9V01.5

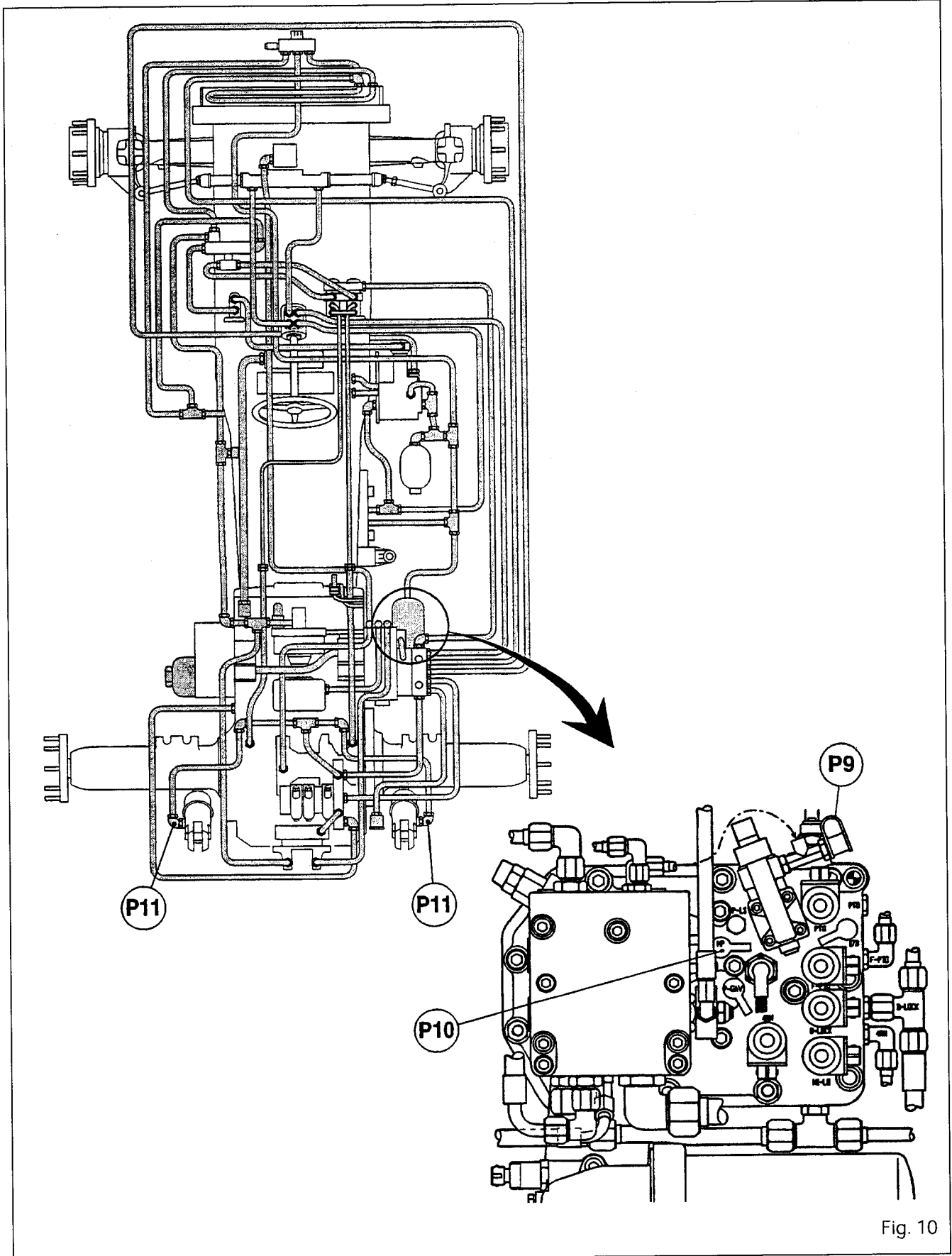

Fig. 10





9V01.6

## 6100 SERIES TRACTORS

**Hydraulics - Closed centre****7. Steering****Maximum pressure**

- Connect a pressure gauge to each diagnostic connector and run the engine as described in paragraph 6.
- Slowly turn the steering wheel and check that **P12** and **P13** gradually increase (Fig. 11).

**P12 = 145 bars****P13 = 170 bars****Shock valve**

- With the engine stopped, connect a hand-operated calibrating pump under one of the two steering ram supply points.
- Apply pressure with the calibrating pump (Fig. 11):  
**P14 = 225 to 250 bars**
- Carry out the same procedure for the second steering ram supply point.

**Checking the steering circuit for leaks**

- Run the engine at 1,000 rpm.
- Apply full steering lock and apply a torque of 4 Nm on the steering wheel. It must not turn at more than 2 revolutions per minute. If the steering wheel turns at more than 2 rpm, disconnect the lines supplying the rams and block the two openings.
- Apply the same torque on the steering wheel. If it turns at less than 2 rpm, there is a leak from the ram.

**8. Trailer brake (if fitted)****Maximum pressure**

- Connect a pressure gauge to the quick coupler on the trailer brake system (Fig. 11) to read **P15**.
- Run the engine at 2,200 rpm.
- With the brake pedals coupled together, gradually apply force.
- The pressure reading must gradually increase to reach:  
**P15 = 120 to 150 bars**
- If the pressure does not increase gradually, bleed the brake circuit.

**Flowrate**

- Connect a flowmeter to the quick coupler on the trailer brake system. Connect the return to the filling port and read **Q3**.

Engine speed rpm	<b>Q3</b> (l/mn) min.
1,000	27



6100 SERIES TRACTORS

**Hydraulics - Closed centre**



9V01.7

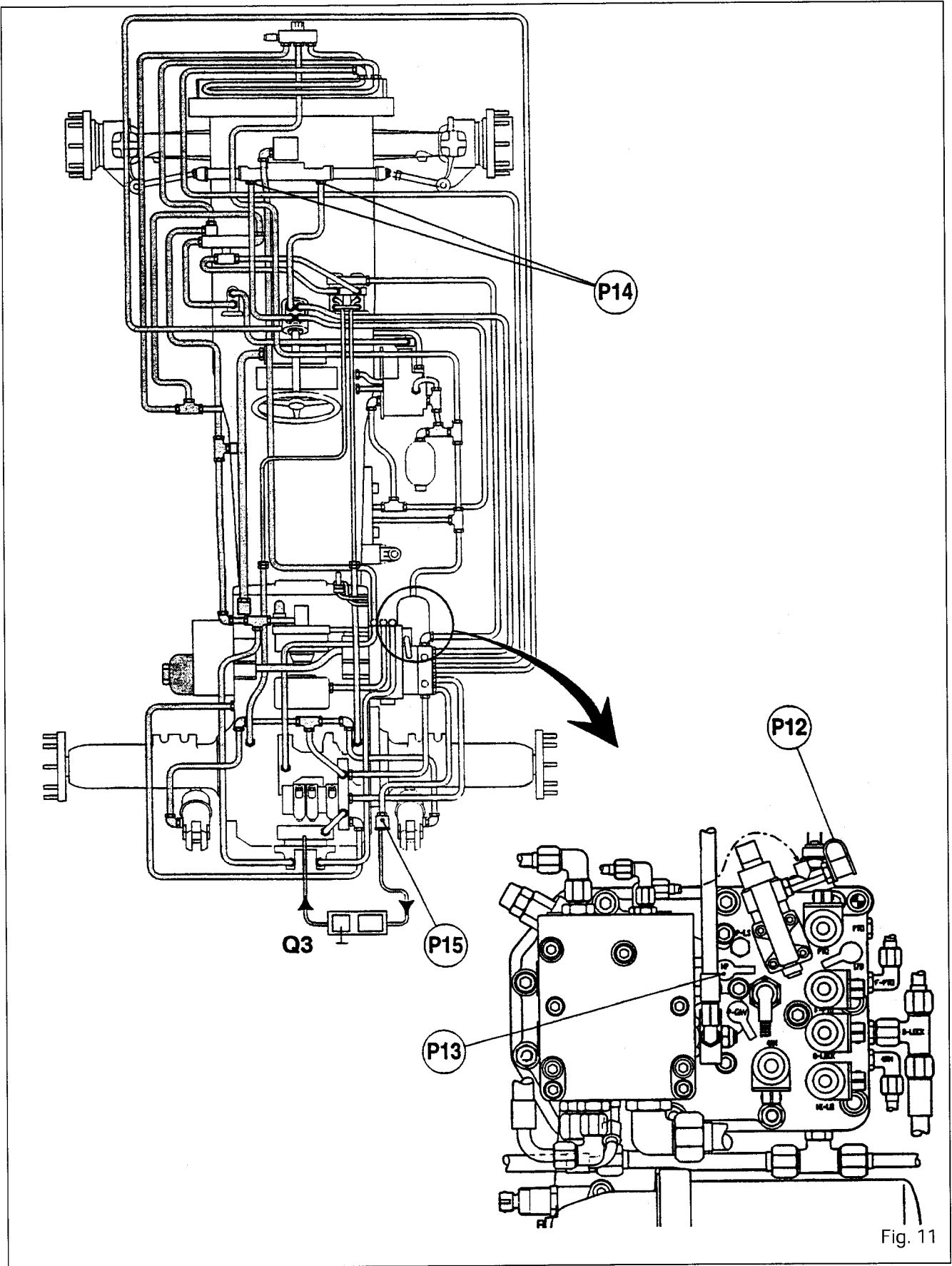

Fig. 11



9V01.8

## 6100 SERIES TRACTORS

**Hydraulics - Closed centre****B. Low-pressure circuit**

The 17-bar low-pressure circuit supplies the following systems:

- Dynashift or Speedshift,
- engine clutch (pressure-loaded only),
- rear power take-off clutch,
- front take-off clutch (if fitted),
- 4WD clutch,
- front and rear differential lock,
- Hare/Tortoise range,
- electrohydraulic reverse shuttle control (if fitted).

**1. 17-bar circuit**

- Connect a pressure gauge to the diagnostic connector (Figures 12 and 14) located to the front of the right-hand hydraulic cover to check **P16**.
  - Run the engine at 1,000 rpm.
  - Declutch (pressure-loaded clutch only) and deactivate all the low-pressure components.  
The front axle must be engaged with the pressure used only for declutching.  
Place the range lever in the Tortoise position and the Dynashift lever in position D.
  - On tractors equipped with Speedshift, place the lever in position C (30 km/h tractor) or position D (40 km/h tractor).
  - **Engage each system. The pressure must not drop below 14 bars** and must return to its initial level when each system is engaged.
- P16 = 17 ± 1 bar**

**2. Booster circuit and cooling safety**

- Connect a pressure gauge to the diagnostic connector located on the right-hand cover (Figures 13 and 14) to check **P17**.

Engine speed rpm	<b>P17</b> bar
1,000	5
2,200	6

**3. Oil cooler (optional)**

- As shown in Figure 14, connect a pressure gauge to the cooler inlet to check **P18** and onto the cooler outlet to test **P19**.

Engine speed rpm	<b>P18</b> (bar)	<b>P19</b> (bar)
1,000	2	1,9
2,200	2,3	2

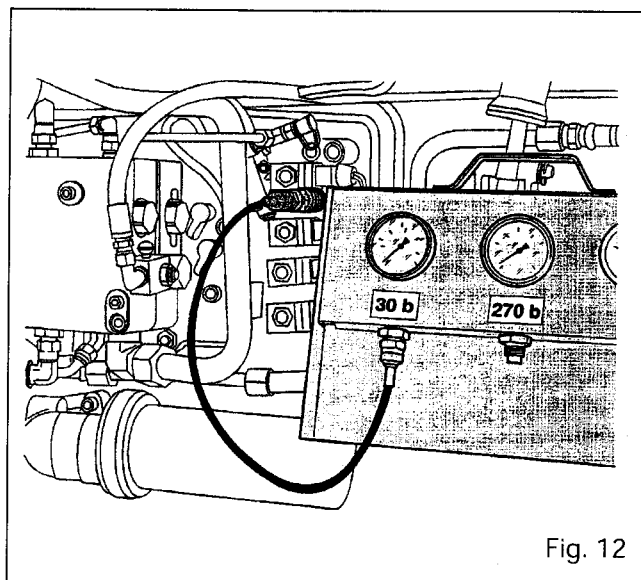

Fig. 12

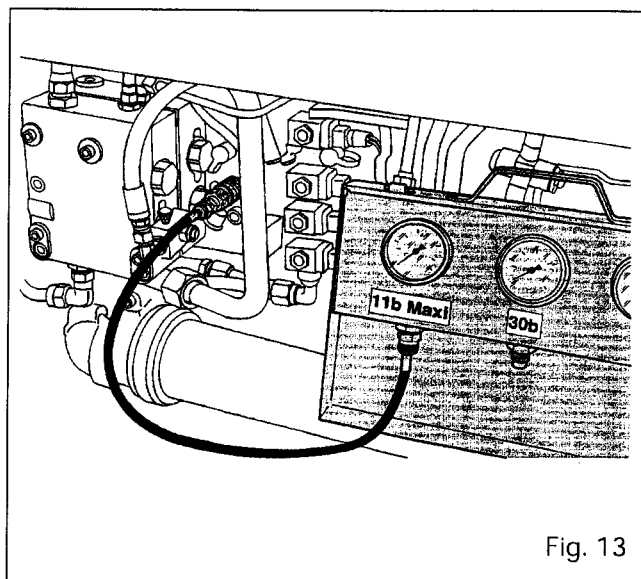

Fig. 13



6100 SERIES TRACTORS

**Hydraulics - Closed centre**



9V01.9

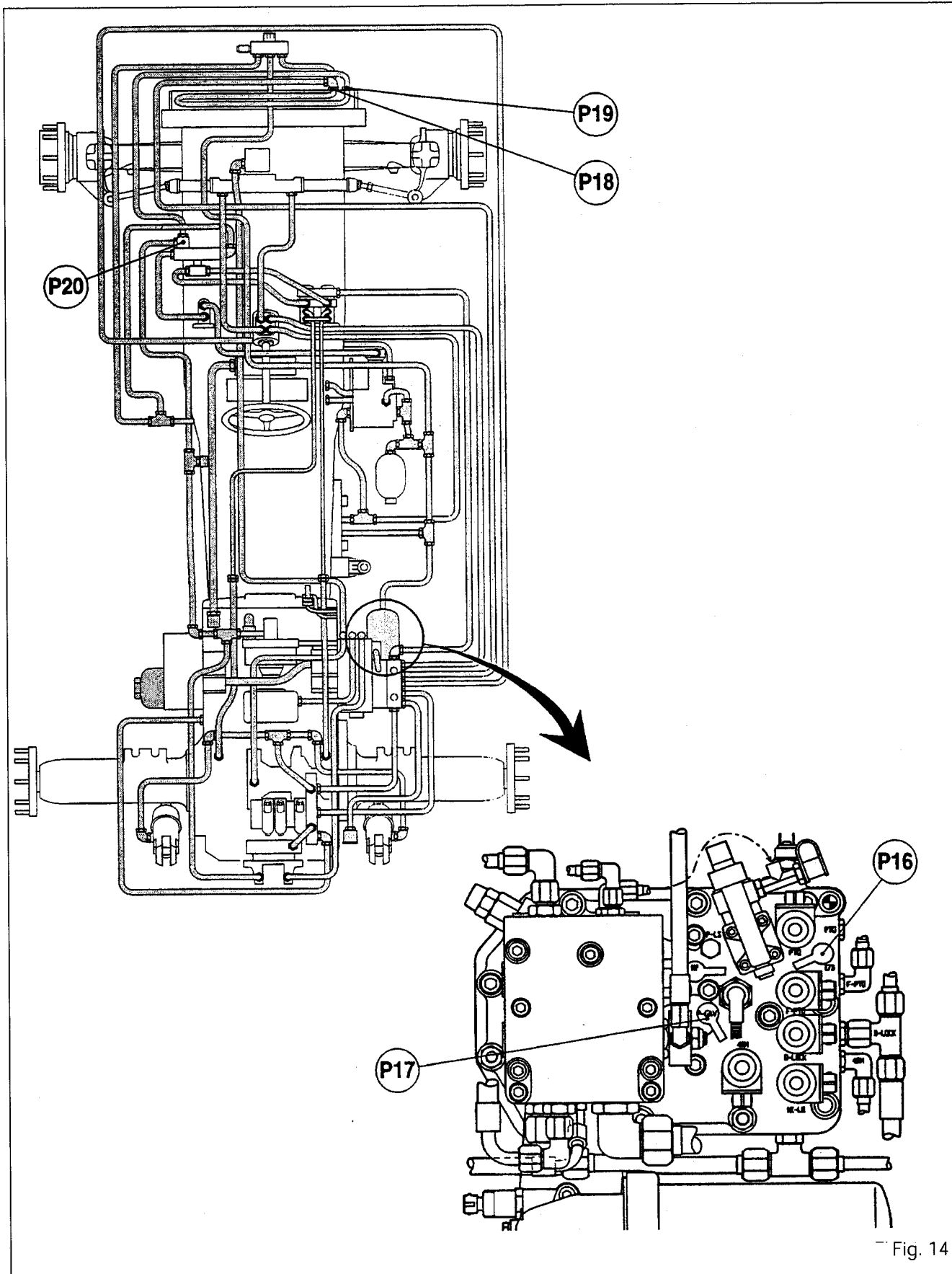

Fig. 14



9V01.10

## 6100 SERIES TRACTORS

**Hydraulics - Closed centre****4. Transmission lubricating circuit****a) Pressure test**

- Tractor with or without additional tank
- Connect a pressure gauge to the connector located under the manifold to check **P20** (Fig. 14).
- At 1,000 rpm, **P20 = 1.5 bars**

**Important: If an auxiliary spool valve is engaged (in which case a flowmeter or a slave device must be connected to it), the pressure must not drop below 1 bar for P20.**

**b) Flowrate test**

- Connect a flowmeter to the lubricating circuit between the manifold and the gearbox to read **Q4** (Fig. 16).
- Important: It is mandatory that the flowmeter valve must be in the maximum open position until the end of the test.**

Engine speed rpm	<b>Q4</b> (l/mn) min.
1,000	5
2,200	6

If an auxiliary spool valve is engaged (in which case a flowmeter or a slave device must be connected to it), the flowrate must not drop by more than 2 l/mn.

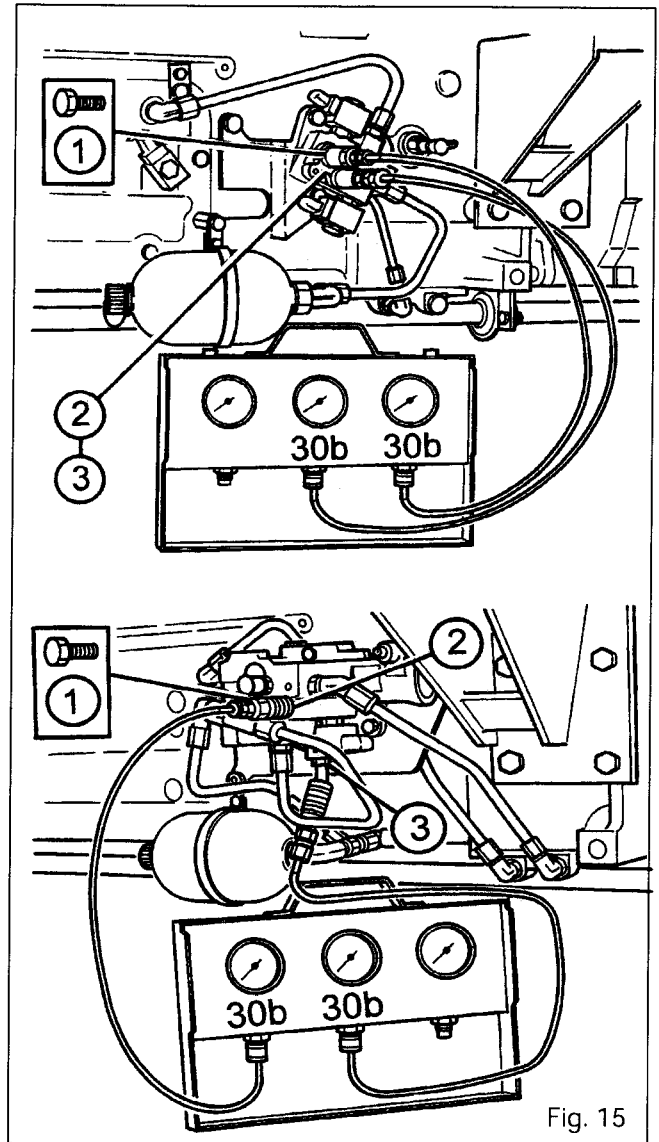

Fig. 15

**5. Pressure of servo systems****a) Dynashift**

- Remove the guard preventing access to the connectors (30 km/h tractors, pressure-loaded clutch).
- Remove the plugs **(1)** from the distribution unit.
- Screw on two male connectors **(2)** and **(3)**, ref. 3384387M1, and connect them to diagnostic connectors fitted on pressure gauges with a capacity of approximately 30 bars (Figures 15 and 16).
- Start the engine.
- Operate the lever under the steering wheel to select each ratio (A, B, C and D).
- Check whether the pressures are correct compared with the table:

Ratio	Front piston connector <b>(2)</b> <b>P22</b> (bar)	Rear piston connector <b>(3)</b> <b>P23</b> (bar)	EV1 (V)	EV1 (V)
A	17	17	12	12
B	17	17	12	12
C	0	0	0	0
D	0	0	0	0

- If the pressures are not correct, check the movement of the spools of the solenoid valves (EV1, EV2) or see the documentation on electrical tests.
- Fit the guard and seal the attaching bolt with lead.

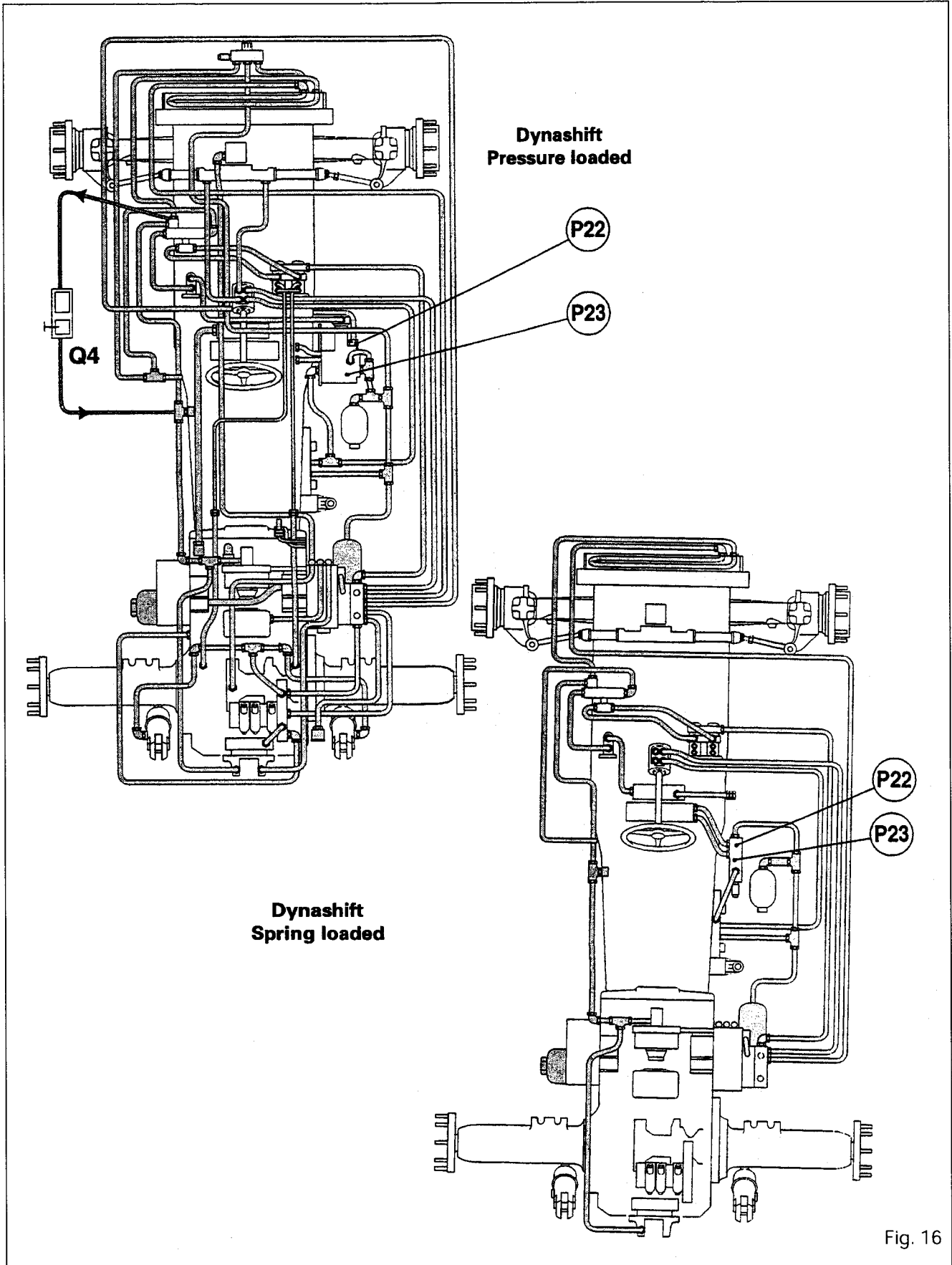

Fig. 16



9V01.12

## 6100 SERIES TRACTORS

**Hydraulics - Closed centre****b) Clutch****Control circuit**

- Connect a pressure gauge to the diagnostic connector of the clutch valve located on the right-hand side of the gearbox (Figures 17 and 20) to check **P24**.
- Operate the pedal to engage or disengage the clutch.

Engine speed rpm	<b>P24</b> (bar) disengaged	<b>P24</b> (bar) engaged
1,000	0	17
2,200	0	17

**Modulation pressure**

- The clutch valve modulates between 11 bars and 0 bar. This modulation corresponds to a pedal travel extending  $32 \pm 1$  mm from the high stop position and  $25 \pm 1$  mm before the pedal low stop position (the total travel being 150 mm).
- If the modulation travel is offset with respect to the pedal travel, the control system must be bled using the bleeder (2) located at the end of the valve (see Section 4A01, § E).

**Clutch lubricating circuit**

- Connect a pressure gauge to the diagnostic connector located on the right-hand side of the gearbox (Figures 18 and 20) to check **P25**.
- Operate the pedal to disengage or engage the clutch.

Engine speed rpm	<b>P25</b> (bar) disengaged	<b>P25</b> (bar) engaged
1,000	2	0,4
2,200	3	1,2

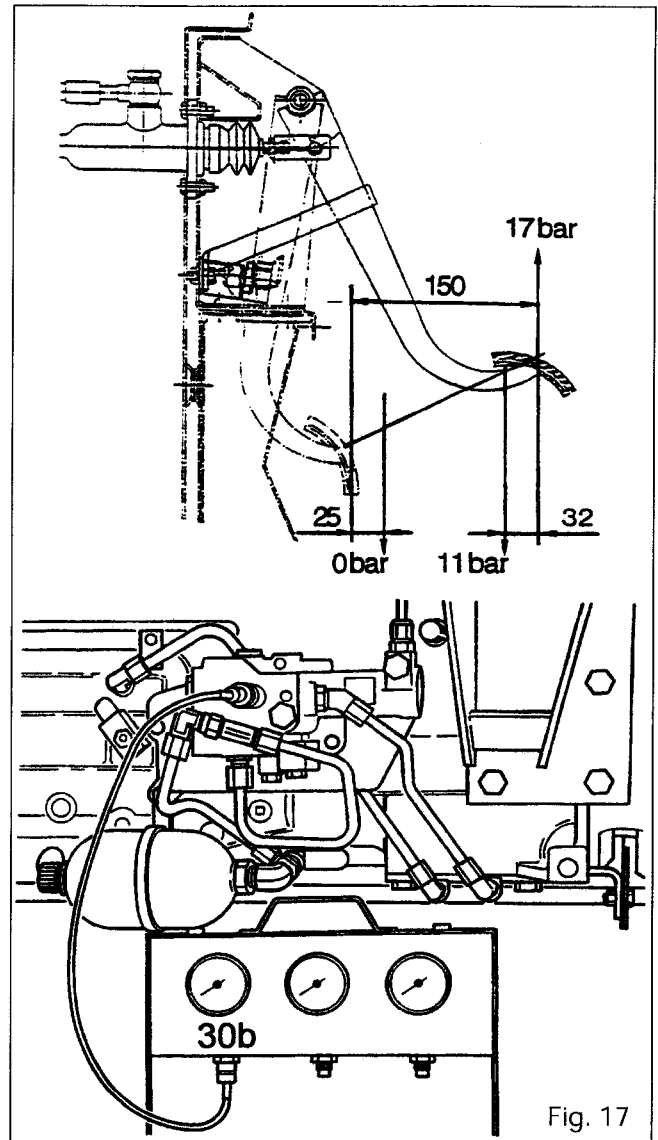

Fig. 17

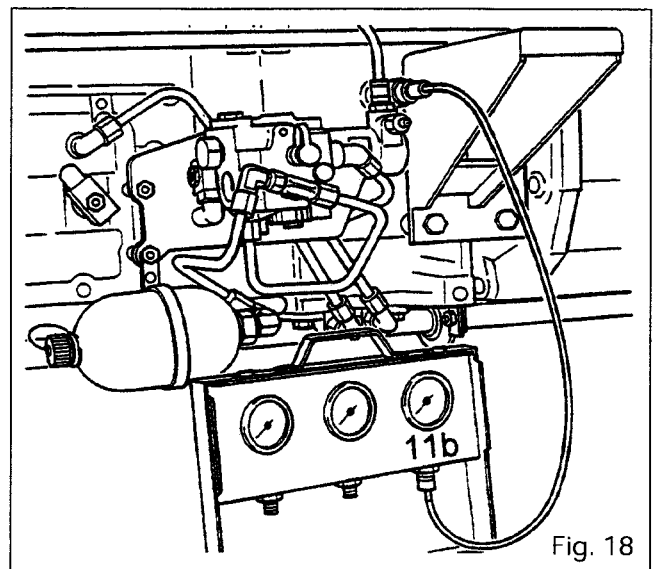

Fig. 18



# 6100 SERIES TRACTORS



9V01.13

## Hydraulics - Closed centre

### Clutch stop (residual pressure)

#### 6110 to 9160 tractors - Spring-loaded engine clutch

Install a pressure gauge equipped with a coupler 3582045M1 onto the bleed connector located on the right-hand side of the gearbox (Fig. 19).

**Caution:** As the pressure can reach about 18 bars when the pedal is pressed, it is mandatory to start the engine before connecting up the pressure gauge.  
Read the pressure: **P26 = 0.5 bar**

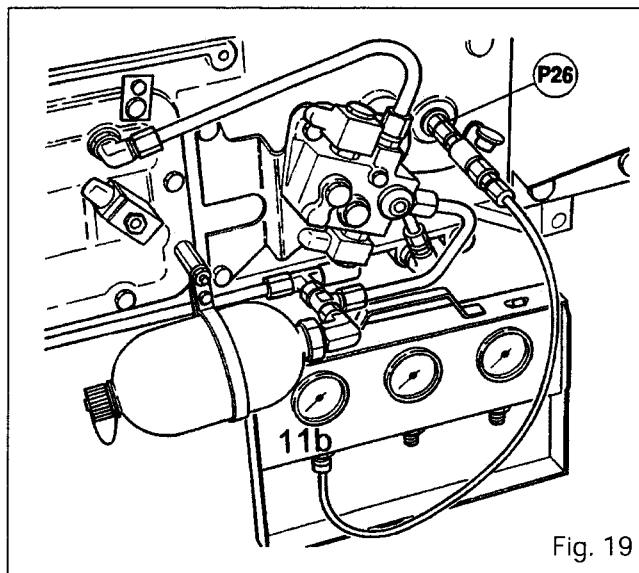

Fig. 19

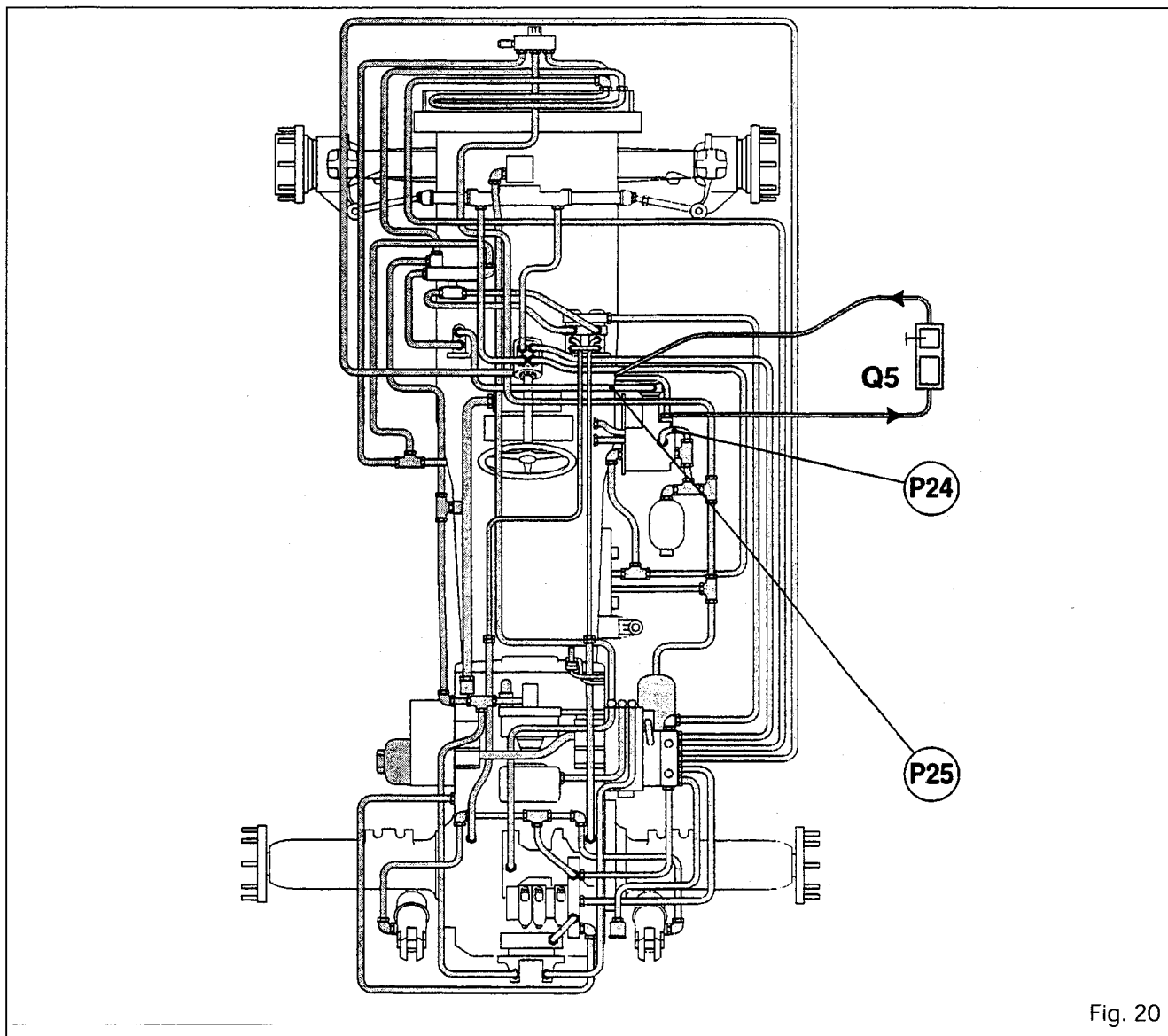

Fig. 20





## 6100 SERIES TRACTORS



9V01.14

### Hydraulics - Closed centre

#### Checking the permissible leakage

- Connect a flowmeter between the valve and the clutch supply point (Fig. 20) and read **Q5**.

Engine speed rpm	<b>Q5</b> disengaged (l/mn)	<b>Q5</b> engaged (l/mn)
1,000	0	3 max.

#### c) Front power take-off (if fitted)

##### Checking the constant level in housing

- Using a probe, measure the outlet flowrate **Q6** and the inlet flowrate **Q7** after the restrictor (Figures 21 and 22).

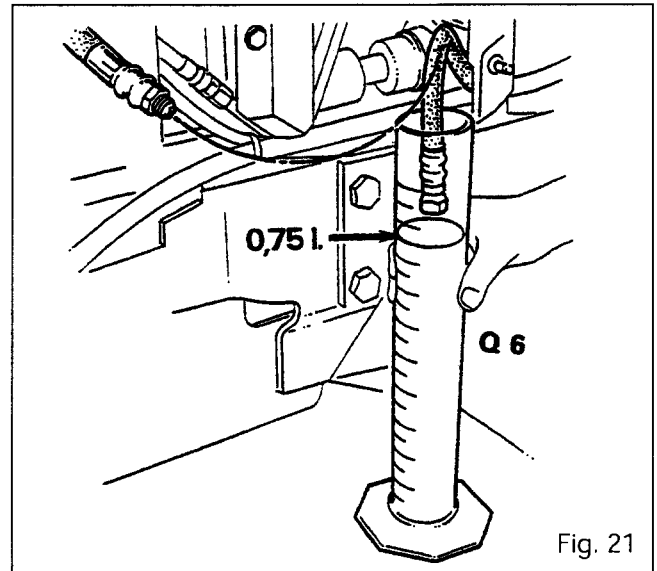

Fig. 21

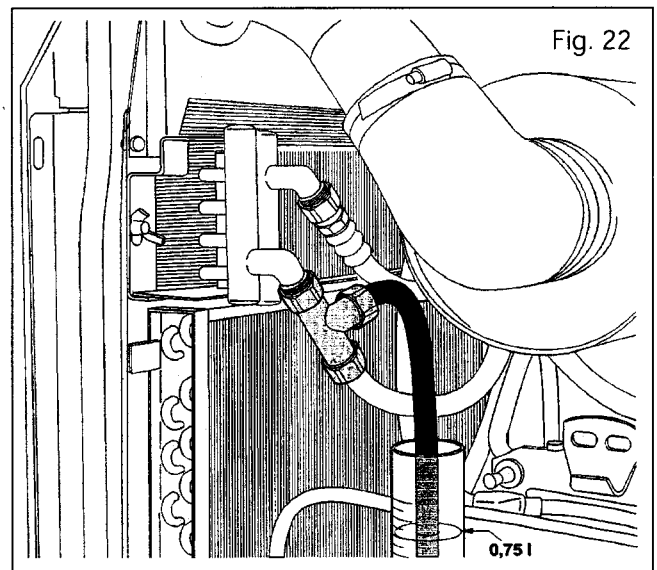

Fig. 22



# **10 . ELECTRICAL EQUIPMENT**

## **Contents**

**10 A01 ELECTRICAL SYSTEM**





**Electrical equipment - System**

*10 A01 Electrical system*

CONTENTS

<b>A.</b>	<b>General</b> _____	<b>2</b>
<b>B.</b>	<b>Engine and equipment wiring</b> _____	<b>3</b>
<b>C.</b>	<b>Lighting system wiring - all types except USA</b> _____	<b>5</b>
<b>D.</b>	<b>Lighting system wiring - USA type</b> _____	<b>6</b>
<b>E.</b>	<b>Wiring for additional front work lamps</b> _____	<b>7</b>
<b>F.</b>	<b>Fuses</b> _____	<b>8</b>



10A01.2

## 6100 SERIES TRACTORS



# Electrical equipment - System

### A. General

MF 6100 tractors are equipped with a 12-volt electrical system with negative earth, charged by a 70-ampere alternator.

The alternator has an integrated rectifier and charging regulator. An additional terminal is provided to supply power to the electronic engine tachometer. The alternator is fitted on the right-hand side of the engine and is driven by a twin belt from the crankshaft pulley. The starter motor, mounted on the right-hand side of 1000 series engines, is of the pre-engaged type.

A starting safety switch, located under the clutch pedal, cuts off the power supply to the starter motor when the clutch is not pressed.

### Specifications

#### Battery

MF 6110-6120-6130-6140

Quantity	1
Make	CEAC
Type	Maintenance-free
Model	FCM 125388
Cold start performance	505 A (-18°C)
Reserve capacity at 25 A	120 mn
Voltage	12 V
Acid capacity	8.2 l

MF 6110-6120-6130-6140 (cold countries)

MF 6150 to 6190

Quantity	2
Make	CEAC
Type	Maintenance-free
Model	FCM 066431
Cold start performance	420 A (-18°C)
Reserve capacity at 25 A	120 mn
Voltage	12 V
Acid capacity	4.3 l

#### Alternator

Make	Valeo
Type	NG
Max. output	70 A
Regulator	Integrated
Regulator voltage	14.2 V

#### Starter motor

Make	Magnetti-Marelli
Model	M127 (2.8 kW)
Voltage	12 V
Type	Pre-engaged

### Identification of connectors

Item	Colour	Ways
C1	Black (circular)	9
C2	Black (circular) Red band	9
C3	Black	6
C4	Black	6
C5	White	5
C7	White	13
C8	Black	2
C9	Black (circular)	3
C10	Black	1
C11	Black	1
C12	Red	2
C13	Black	1
C14	White	5
C16	White	4
C17	Black	3
C18	Black	6
C19	Black	2
C20	Black	1
C21	Black	2
C22	Black	2
C23	Black	1
C24	Black	8
C25	Black	1
C26	Black	1
C27	Black	1
C28	Black	3
C30	White	13
C31	White	11
C33	Black	2
C34	Black	2
C60	Black	6

### Identification of harnesses

Item	Description of harnesses
(a)	Instrument panel harness
(b)	Engine harness
(c)	Engine harness extension
(d)	Console harness
(e)	Starting assistance wire
(f)	Internal power socket supply harness
(g)	Roof harness
(h)	Battery main switch harness
(i)	Rear wiper harness
(j)	Wire (for power supply to radio, clock and interior light) (for battery main switch)
(k)	Additional tank harness
(l)	Interior light door switch harness
(m)	Instrument panel electronic harness
(o)	Battery harness
(t)	Instrument panel / roof harness (lower section)
(u)	Instrument panel / roof harness (upper section)
(w)	Front and rear lighting harness
(ae)	25 A internal power socket harness
(af)	Cigar lighter harness



---

6100 SERIES TRACTORS

---



***Electrical equipment - System***

10A01.3



## 6100 SERIES TRACTORS

10A01.3

# Electrical equipment - System

## B. Engine and equipment wiring

### 1. Cab equipment and accessories

#### Key to diagram

1. Starter switch
2. Pressure switch
3. Air-conditioning compressor
4. Cab relay
5. Brake oil pressure warning light
6. Alternator warning light
7. Radio (NA)
8. Radio (except NA)
9. Digital clock
10. Interior light
11. Door switch
12. Water circulating pump (optional)
13. Switch (optional)
14. Blower switch
15. Blower motor
16. Compressed air thermostart
17. Starter motor
18. Battery
19. Battery main switch (optional)
20. Windscreen wiper motor
21. Interior power socket
22. Overhead panel illumination
23. Windscreen washer pump
24. Parking brake switch
25. Rear wiper switch
26. Cigar lighter
27. Timing relay
28. Parking brake warning light
29. Rear wiper motor
30. Wiper selector switch

#### Colour code

- A = Aluminium
- B = White
- BL = Blue
- G = Grey
- I = Ivory
- J = Yellow
- M = Brown
- N = Black
- O = Orange
- R = Red
- RO = Pink
- V = Green
- VI = Violet
- C = Light
- F = Dark

#### Abbreviations

- HB: Handbrake buzzer (if fitted)
- PB: Pneumatic brake (if fitted)
- PS: Pneumatic seat (if fitted)

emb: end fitting

+ P = + permanently live

+ AC = + live when ignition is on

**Note: If the alternator warning light (6) does not come on when the starter switch is in position 2, check that the bulb has not blown. If it has blown, the alternator will not be energised and will not charge, which renders the lift function inoperative.**



Electrical equipment - System



10A01.3

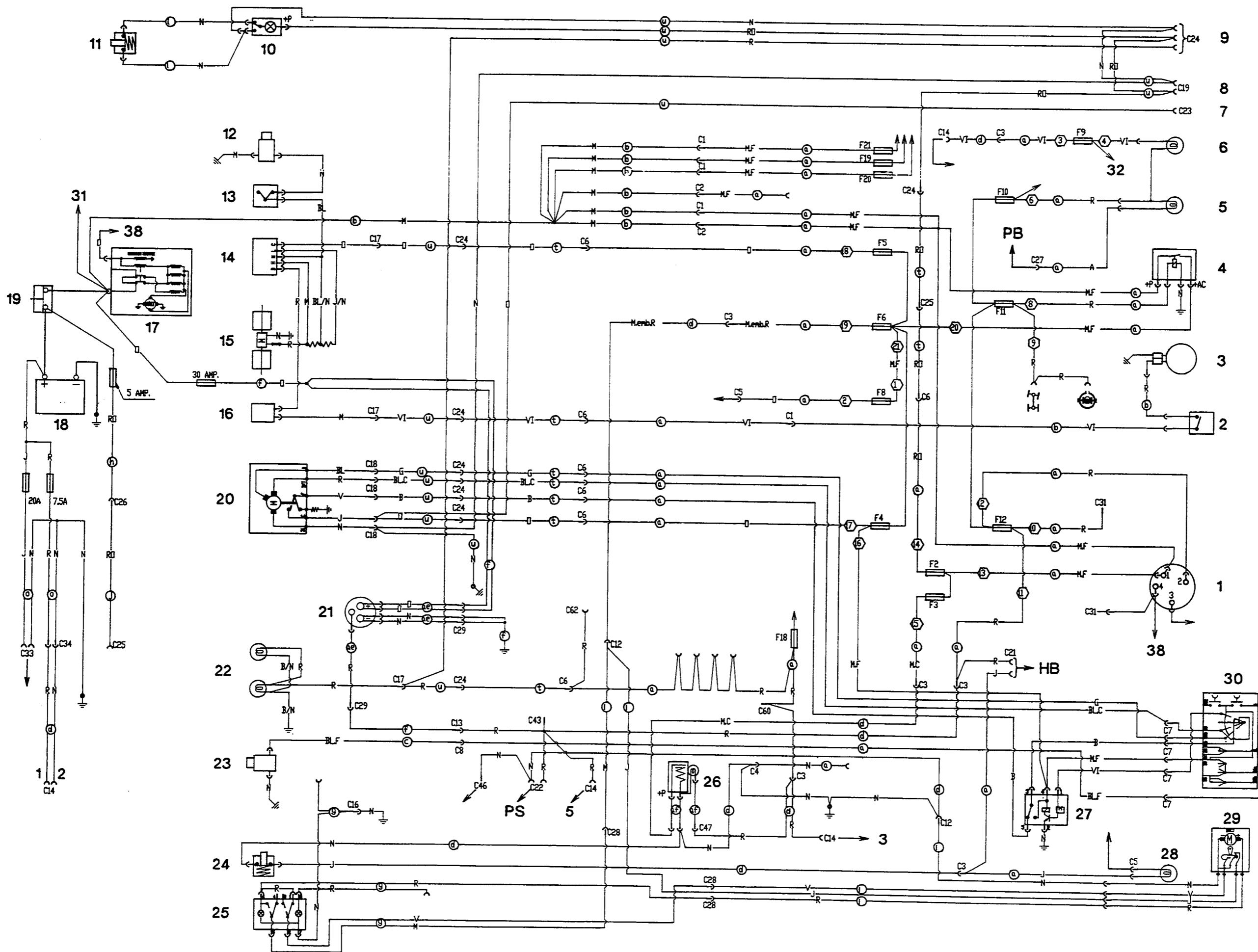





10A01.4

## 6100 SERIES TRACTORS

**Electrical equipment - System****2. Engine equipment****Key to diagram**

1. Starter switch
6. Alternator warning light
17. Starter
18. Battery
19. Battery main switch (optional)
31. Safety switch
32. Alternator
33. Engine oil pressure switch
34. Temperature gauge
35. Fuel gauge
36. Air filter vacuum gauge
37. Hydraulic filter vacuum switch
38. Gauges with additional fuel tank
39. Rev. counter / totaliser
10. Engine oil pressure warning light
11. Water temperature gauge
12. Fuel gauge indicator
13. Air filter clogging warning light
14. Hydraulic filter clogging warning light
15. Injection pump control solenoid
17. Thermostart
18. Hydraulic filter clogging indicator
19. Hydraulic low-pressure switch

**Colour code**

- A = Aluminium
- 3 = White
- 3L = Blue
- 3 = Grey
- = Ivory
- 1 = Yellow
- 1 = Brown
- 1 = Black
- 0 = Orange
- 3 = Red
- 30 = Pink
- 1 = Green
- 1 = Violet
- 3 = Light
- 1 = Dark

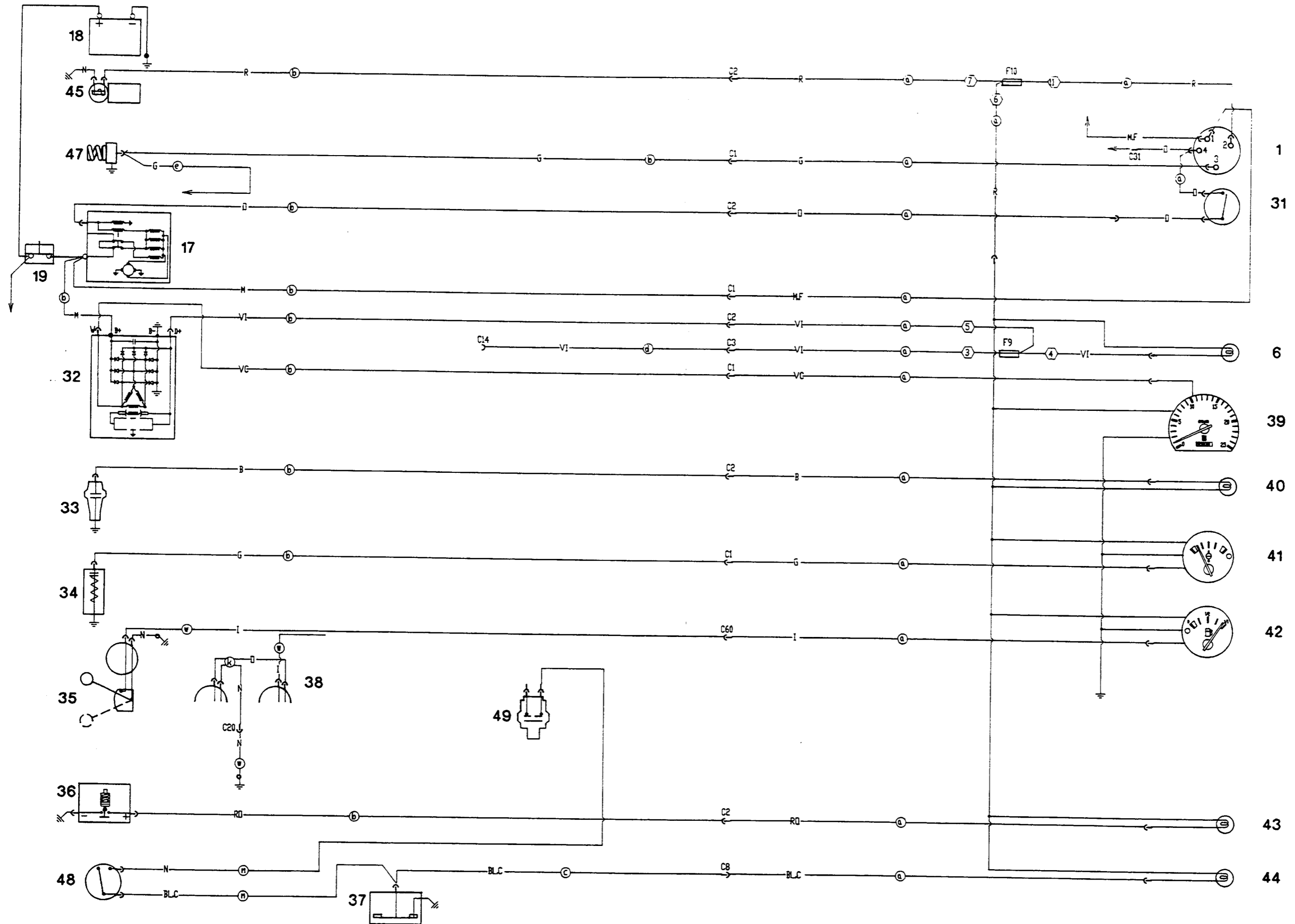



10A01.5

## 6100 SERIES TRACTORS

**Electrical equipment - System****C. Lighting system wiring - all types except USA****Key to diagram**

1. Starter switch
2. Stop switches
3. Rear RH direction indicator
4. Rear RH brake light
5. Rear RH work lamp
6. Number-plate lights
7. Power socket
8. Rear LH work lamp
9. Rear LH brake light
10. Rear LH direction indicator
11. Front LH direction indicator
12. Front LH parking light
13. Front LH work lamp
14. Front LH headlight
15. Horn
16. Front RH headlight
17. Front RH work lamp
18. Front RH parking light
19. Front RH direction indicator
20. Flashing beacon
21. Flashing beacon switch
22. Flasher unit
23. Lighting selector switches
24. Hazard warning light switch
25. Instrument panel assembly illumination
26. LH direction indicator warning light
27. RH direction indicator warning light
28. Front headlight main beam warning light
29. 1st trailer warning light
30. 2nd trailer warning light
31. Rear work lamps switch
32. Front work lamps switch
33. Rear work lamp relays
34. Front work lamp relays
35. Front and rear work lamp relays
36. Fuel gauge

**Colour code**

A = Aluminium	N = Black
B = White	R = Red
BL = Blue	RO = Pink
G = Grey	V = Green
I = Ivory	VI = Violet
J = Yellow	F = Dark
M = Brown	

**Abbreviations**

- + P = + permanently live  
+ AC = + live when ignition is on

**Identification of connectors**

Item	Colour	Ways
C7	White	13
C9	Black	3
C10	White	6
C16	White	4
C60	White	6
C62	White	6
C63	Black	6
C64	White	2
C65	White	2
C66	Black	4
C67	Black	4
C68	Black	2
C69	Black	2
C70	Black	1
C71	Black	1
C72	Black	2
C73	Black	2
C74		1 Tubular connection
C75	Black	6
C76	Black	6
C77	Black	2

**Identification of harnesses**

Item	Description of harnesses
(a)	Instrument panel harness
(b)	Engine harness
(g)	Roof harness
(t)	Instrument panel/roof (lower section)
(u)	Instrument panel/roof harness (upper section)
(v)	Front work lamps harness (accessories)
(w)	Front and rear lighting harness
(x)	Roof lighting harness
(y)	Number-plate illumination harness
(ag)	Instrument panel / roof illumination harness
(ah)	Roof lights harness

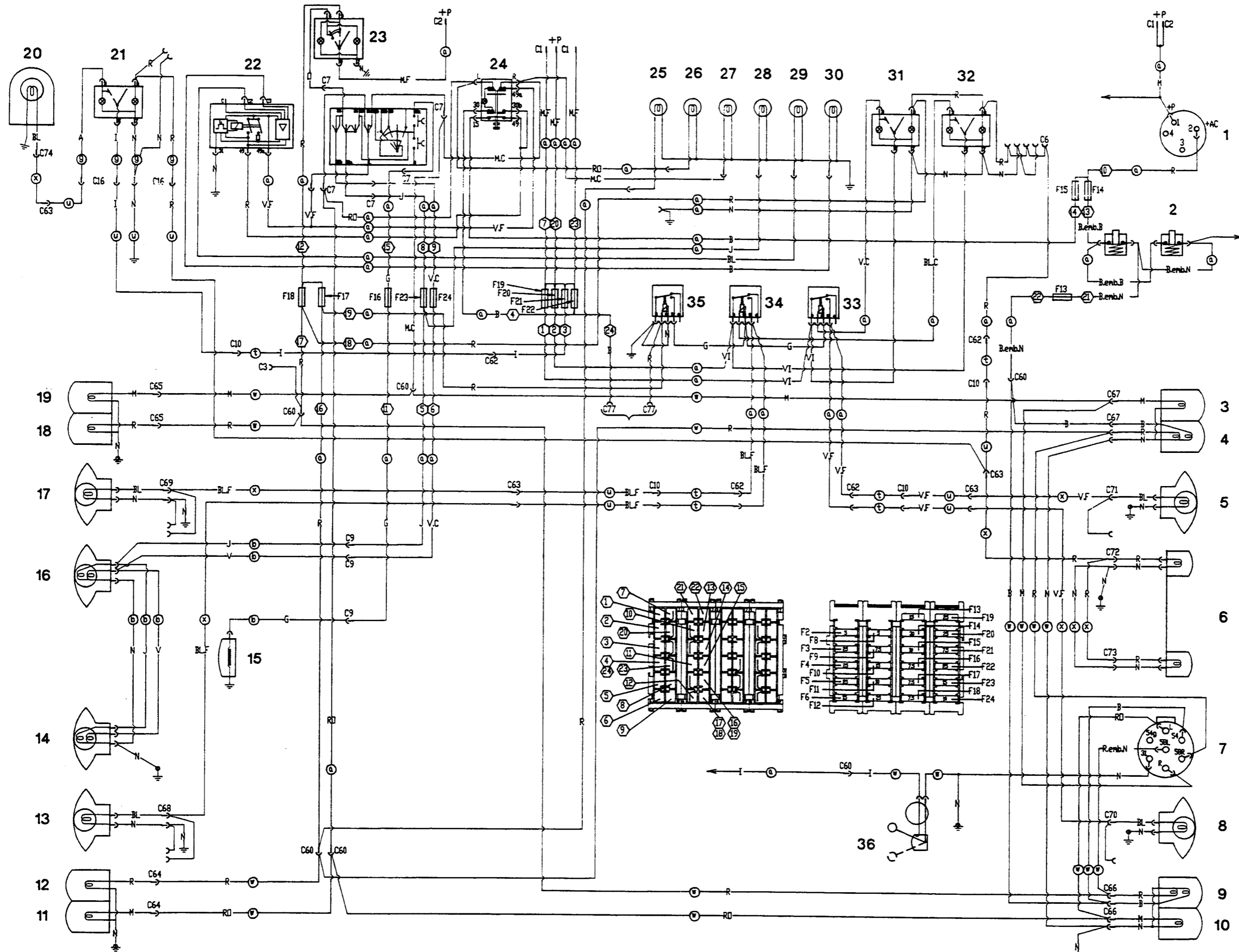



10A01.6

## 6100 SERIES TRACTORS

**Electrical equipment - System****D. Lighting system wiring - USA type****Abbreviations**

- + P = + permanently live  
+ AC = + live when ignition is on

**Key to diagram**

1. Starter switch
2. Stop switches
3. Rear RH direction indicator
4. Rear RH brake light
5. Rear RH work lamp
6. Number-plate lights
8. Rear LH work lamp
9. Rear LH brake light
10. Rear LH direction indicator
11. Front LH direction indicator
13. Front LH work lamp
14. Front LH headlight
15. Horn
16. Front RH headlight
17. Front RH work lamp
19. Front RH direction indicator
22. Flasher unit
23. Lighting selector switches
24. Hazard warning light switch
25. Instrument panel assembly illumination
26. LH direction indicator warning light
27. RH direction indicator warning light
28. Front headlight main beam warning light
29. 1st trailer warning light
30. 2nd trailer warning light
31. Front work lamps switch
32. Rear work lamps switch
33. Rear work lamp relays
34. Front work lamp relays
36. Fuel gauge

**Identification of connectors**

Item	Colour	Ways
C7	White	13
C9	Black	3
C10	White	1
C16	White	4
C60	White	6
C62	White	6
C63	Black	6
C64	White	2
C65	White	2
C66	Black	3
C67	Black	3
C68	Black	2
C69	Black	2
C70	Black	1
C71	Black	1
C72	Black	2
C73	Black	2
C74		1 Tubular connection
C75	Black	6
C76	Black	6
C77	Black	2

**Colour code**

- A = Aluminium  
B = White  
BL = Blue  
G = Grey  
I = Ivory  
J = Yellow  
M = Brown  
N = Black  
R = Red  
RO = Pink  
V = Green  
VI = Violet  
F = Dark

**Identification of harnesses**

Item	Description of harnesses
(a)	Instrument panel harness
(b)	Engine harness
(g)	Roof harness
(t)	Instrument panel/roof harness (lower section)
(u)	Instrument panel/roof harness (upper section)
(v)	Front work lamps harness (accessories)
(w)	Front and rear lighting harness
(x)	Roof lighting harness
(y)	Number-plate illumination harness
(ag)	Instrument panel/roof illumination harness
(ah)	Roof lights harness

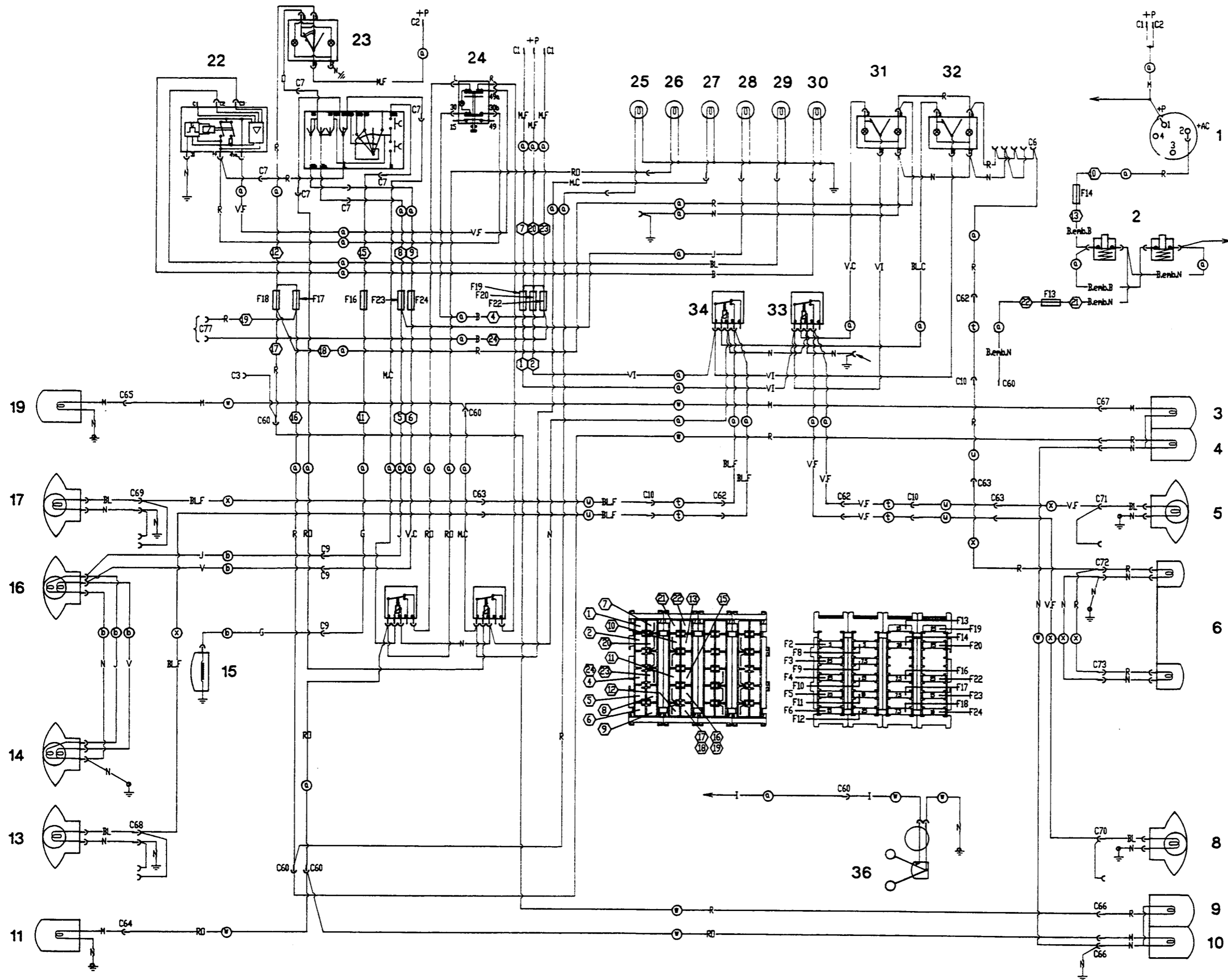



# 6100 SERIES TRACTORS



10A01.7

## Electrical equipment - System

### E. Wiring for additional front work lamps (optional)

#### Key to diagram

- 40. Switch
- 41. Relay
- 42. Front LH work lamp
- 43. Front RH work lamp

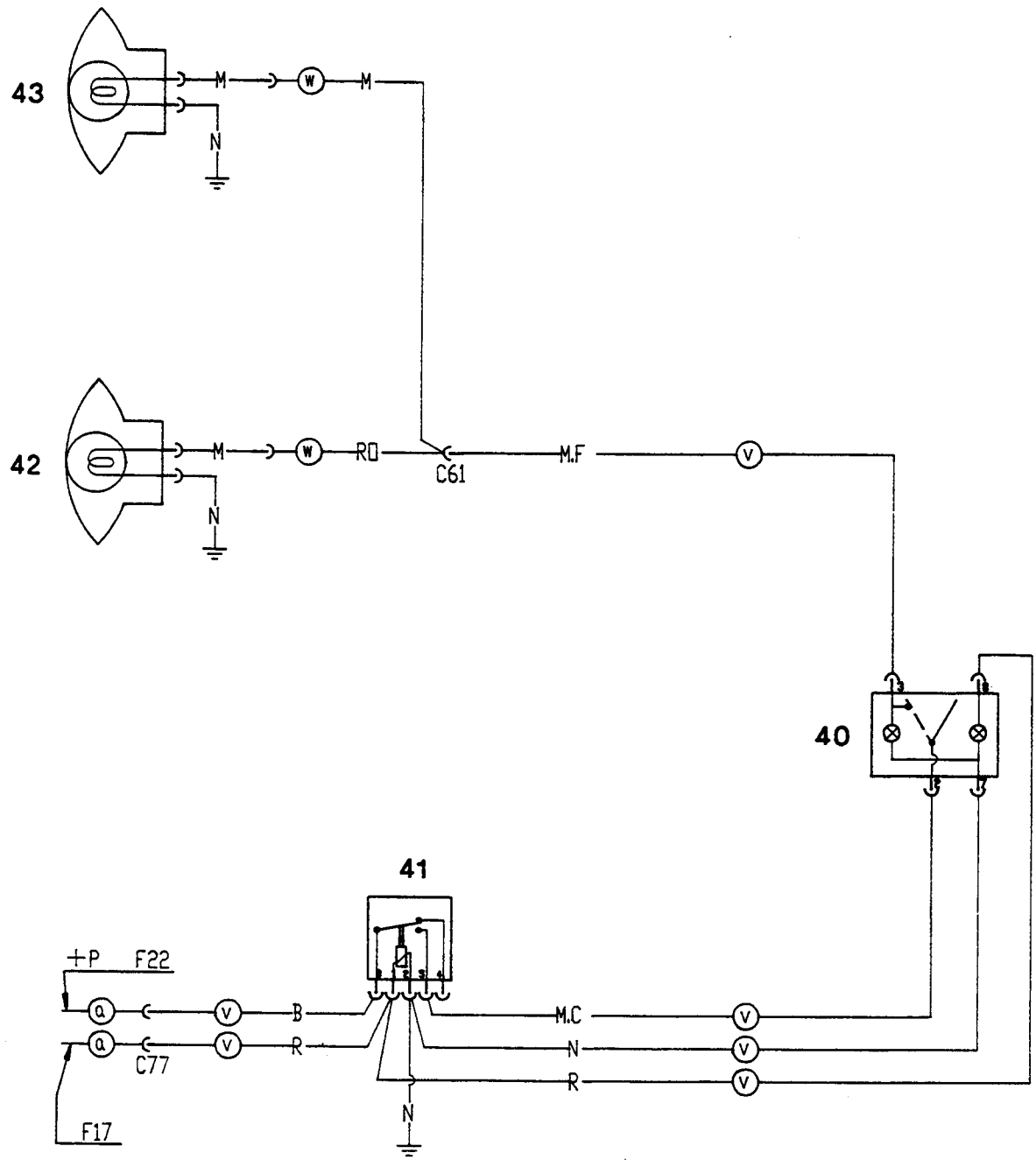



10A01.8

6100 SERIES TRACTORS



Electrical equipment - System

F. Fuses

Fuses are housed in a box located to the left of the instrument panel. The box is divided into two sections. The upper section contains the fuses for the lighting system and the lower part contains the fuses protecting the engine and electronic functions.

A special tool (25) located in the box allows fuses to be replaced easily.

**Note: The fuse box should always be kept clean. Fuses with a higher rating than the specified rating must never be used. The origin of the failure should always be traced before replacing a blown fuse.**

In addition to those fitted in the fuse box, the system is also equipped with other fuses, as follows:

- four fuses fitted at the front:
  - . 7.5 A fuse (brown) protecting the electronic lift unit,
  - . 15 A fuse (blue) protecting the Autotronic unit,
  - . 5 A fuse (yellow) protecting the front PTO (if fitted);
  - . 30 A fuse protecting the interior power supply socket.

ITEM No.	AMP.	APPLICATION
1-7		Not used
2	5	(+P) - Radio, clock and interior light pre-equipment
3	25	(+P) - Cigar lighter
4	25	(+AC) - Front windscreen wiper and washer
5	25	(+AC) - Cab blower
6	15	(+AC) - Rear wiper
8	5	(+AC) - Dynashift control
9	7.5	(+AC) - Electronic lift, Alternator warning light
10	15	(+AC) - Instrument panel assembly, Injection pump
11	10	(+AC) - 4WD and differential lock switch, Cabin relay
12	25	(+AC) - TPM computer, Parking brake buzzer, Pneumatic suspension seat, Creeper gears, Interior power socket, Hare/Tortoise, Lift, PTO switch, Autotronic
13	15	(+AC) - In series with F14, Stop switch and brake lights
14	30	(+AC) - TCU braking information
15	10	(+AC) - RH and LH indicators
16	7.5	(+AC) - Horn
17	7.5	Lighting relay control, Lighting, front LH sidelights, RH rear red light
18	7.5	Illumination of instrument panel assembly, Illumination of clock, differential lock, Front RH sidelight, LH red light, Illumination of switches/buttons, Illumination of number-plate
19	25	(+P) - Rear work lamp
20	25	(+P) - Front work lamp
21	7.5	(+P) - Flashing beacon switch
22	25	(+P) - Hazard warning lights, Additional work lamps (if fitted)
23	15	Headlights (main beam) and indicator light
24	10	Headlights (dipped beam)

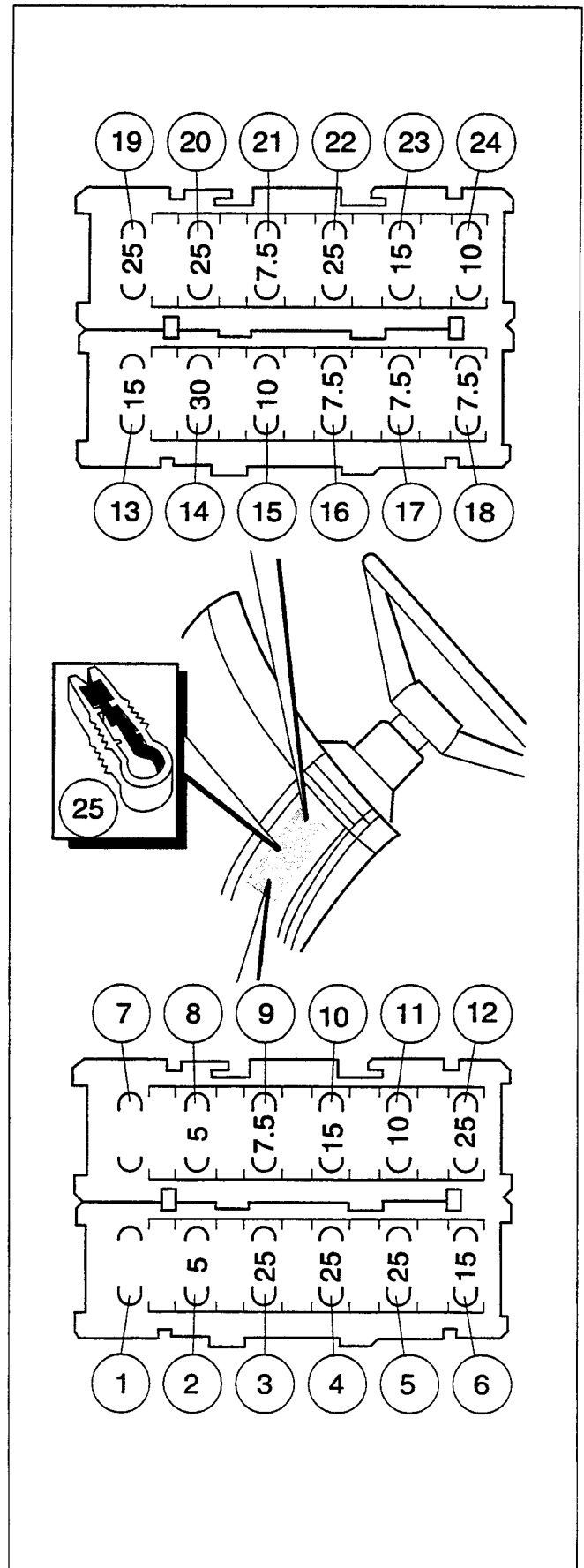

(+P) = + permanently live (+AC) = + live when ignition is on





# **11 . ELECTRONICS**

## **Contents**

- 11 A01 TESTER-PROGRAMMER - DESCRIPTION**
- 11 A02 TESTER-PROGRAMMER - REPROGRAMMING**
- 11 B01 ELECTRONIC LIFT CONTROL - GENERAL DESCRIPTION**
- 11 B02 ELECTRONIC LIFT CONTROL - ELECTRICAL DIAGRAM**
- 11 B03 ELECTRONIC LIFT CONTROL - AUTO-DIAGNOSTIC**
- 11 B04 ELECTRONIC LIFT CONTROL - CHECKING WITH TESTER**
- 11 C01 AUTOTRONIC 2 - DESCRIPTION**
- 11 C02 AUTOTRONIC 2 - CHECKING WITHOUT TESTER**
- 11 C03 AUTOTRONIC 2 - CHECKING WITH TESTER**
- 11 C04 AUTOTRONIC 2 - PARAMETERS**
- 11 C05 AUTOTRONIC 2 - REPROGRAMMING**
- 11 D01 DATATRONIC 2 - DESCRIPTION**
- 11 D02 DATATRONIC 2 - USING THE TESTER**





**Tester-programmer - Description**

*11 A01 Tester-programmer*

CONTENTS

<b>A.</b>	<b>General - Description</b> _____	<b>2</b>
<b>B.</b>	<b>Composition of kit</b> _____	<b>3</b>
<b>C.</b>	<b>Using the tester</b> _____	<b>3</b>
<b>D.</b>	<b>Connecting the tester</b> _____	<b>3</b>
<b>E.</b>	<b>Screen displays</b> _____	<b>6</b>
<b>F.</b>	<b>ETCU modes</b> _____	<b>10</b>
<b>G.</b>	<b>Error messages</b> _____	<b>11</b>
<b>H.</b>	<b>Multimeter function</b> _____	<b>11</b>



11A01.2

## 6100 SERIES TRACTORS

**Tester-programmer - Description****A. General - Description**

**Note : These sections concern the use of the tester-programmer on all tractors in series 6100 and 8100.**

The following testers should be used according to the local language and speed limits:

- 3376941M1	30 km/h	French
- 3376942M1	40 km/h	French
- 3376943M1	30 km/h	English
- 3376944M1	40 km/h	English
- 3376945M1	30 km/h	German
- 3376946M1	40 km/h	German
- 3376947M1	30 km/h	Spanish
- 3376948M1	40 km/h	Spanish

The tester-programmer allows you to :

- monitor the operation of main electronic components and detect failures of the following systems :
  - . Autotronic,
  - . Electronic lift control,
  - . Datatronic.
- parameterise the various electronic components according to the specifications of the tractor they are installed on.

**Autotronic**

- load a new program into the Autotronic 2 electronic transmission control unit (ETCU) in order to update its programming.
- set the parameters on a replacement Autotronic 2 unit before installing it on a tractor.
- test the Autotronic 2 system.

**Electronic lift control**

- possibility of monitoring the operation of the system and detecting failures.
- checking of the adjustment of the position sensor.

**Datatronic**

- as in the case of the Autotronic unit, allows the Datatronic unit to be configured according to the specifications of the tractor it is installed on.
- checks the various values calculated by the Datatronic unit.
- allows the menu to be displayed in the desired language.

**List of parts**

- 1 - Cable harness/tester connector
- 2 - Connector for Autotronic unit (CAN)
- 3 and 4 - Power supply and earth terminals
- 5 - On/Off switch
- 6 to 10 - Keypad
- 11 - Screen display contrast adjustment
- 12 - Input for earth continuity test
- 13 - Input for testing of voltmeter and frequency-meter

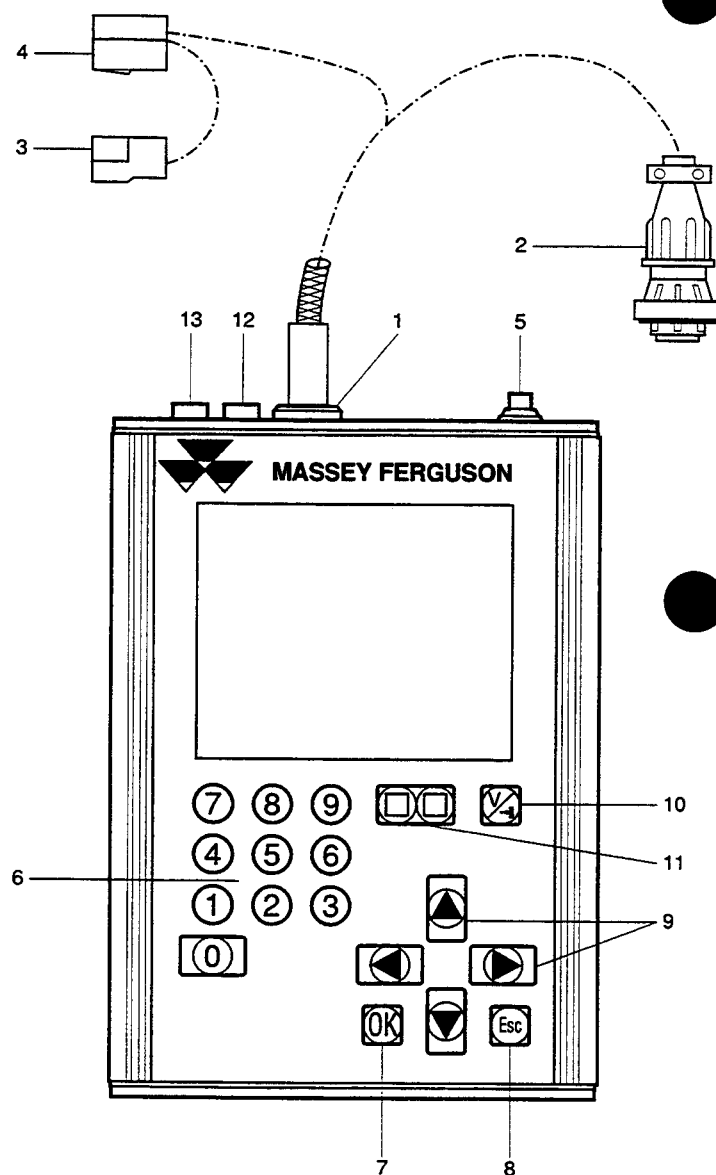



## Tester-programmer - Description

### B . Composition of kit

The basic kit includes:

- a tester box,
- a tester harness (to be connected to the tester),
- an adaptor harness 3714779 M1
- a needle type test lead,
- a carrying case.

The tester does not include any battery and must be connected to the tractor harness to be powered.

On request, the following supplementary harnesses can be supplied :

- 3712344 M1- PC / Tester connecting harness

Used to update or reprogram the tester by means of a PC

- 3712723 M1 : 4-LED harness

Allows the "Auto 2" unit be programmed or parameterised off the tractor (on table)

- 3714780 M1 - Connecting harness on tractors with Datatronic.

To be connected to the 16-way round connector in the cab.

Allows the testing of all electronic systems.

- 3715767 M1 - Connecting harness on tractors without Datatronic.

To be connected to the C35 connector in the cab console.

**Please read the following instructions carefully before switching on the tester.**

### C . Using the tester

The tester is switched ON and OFF by pressing the switch **(5)**. When the tester is switched on, the various tester software issues are shown on the screen.

The various menus are accessed using the keys as indicated at the bottom of the screen. The keypad includes:

- the numeric keypad **(6)** used to enter codes,
- the OK key **(7)** used to validate choices,
- the ESCAPE key **(8)** used to go back to the previous menu,
- the four arrow keys **(9)** used to move the cursor on the display,
- key  $V/- \rightarrow +$  **(10)** used to obtain direct access to the multimeter function from anywhere in the program,
- two keys **(11)** used to adjust the display contrast.

### D . Connecting the tester

Four different possibilities

Connections	On tractor	On table	Testable function			Harness used
			Autotronic II	E.L.C.	Datatronic II	
<b>1</b>	•		•			3714779 M1
(a) <b>2</b>		•	•			3712723 M1
<b>3</b>	•		•	•	• (b)	3715767 M1
<b>4</b>	•		•	•	•	3714780 M1

(a) : This connection allows on the "Auto 2" unit to be parameterised or programmed.

(b) : See section 11 D02

- Connect the tester harness to plug **(1)**.
- Disconnect connector **C33** of the tractor harness. This connector is the direct power supply and earth for the Autotronic system. It is a two-way connector (yellow and black wires) located below the Autotronic box (ETCU).
- Connect the tester connector **(4)** to the adaptor harness 3714779M1 itself connected to the ends of connector **C33** (Fig. 1). In this way, the ETCU power supply is not interrupted.
- Connect connector **(2)** (black) to connector **"E"** of the ETCU after removing of the plug.
- Switch on the tester using the On / Off switch **(5)**.

#### Fault:

If the tester screen does not light up, check the tractor cable harness.

- Yellow wire: direct supply from the battery protected by a 15 A fuse fitted in the battery compartment.
- Black wire: connected to the earth on the gearbox selector cover.
- Check for MINIMUM VOLTAGE of 9 volts on connector **C33**.



11A01.4

# 6100 SERIES TRACTORS



## Tester-programmer - Description

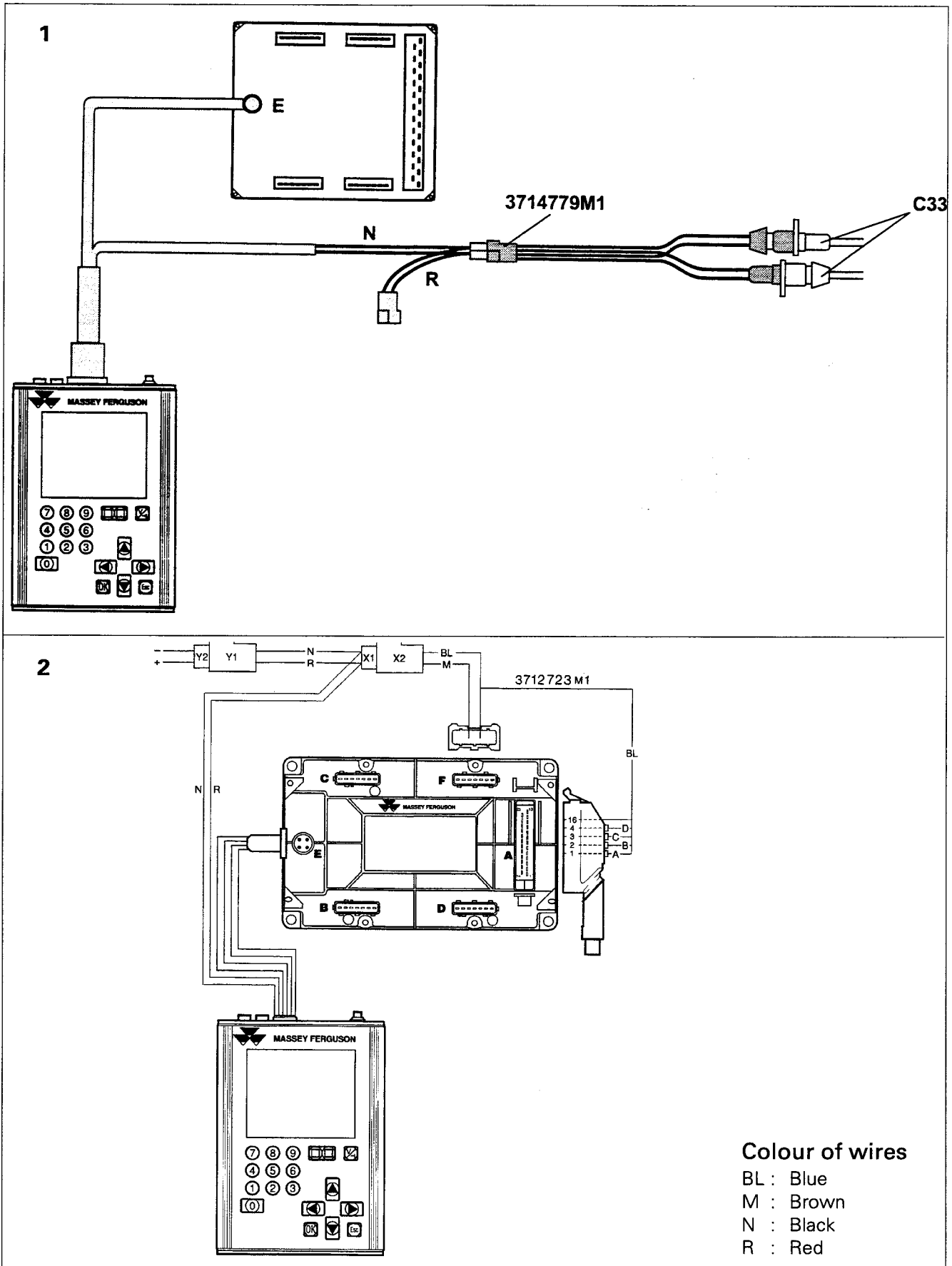



# Tester-programmer - Description

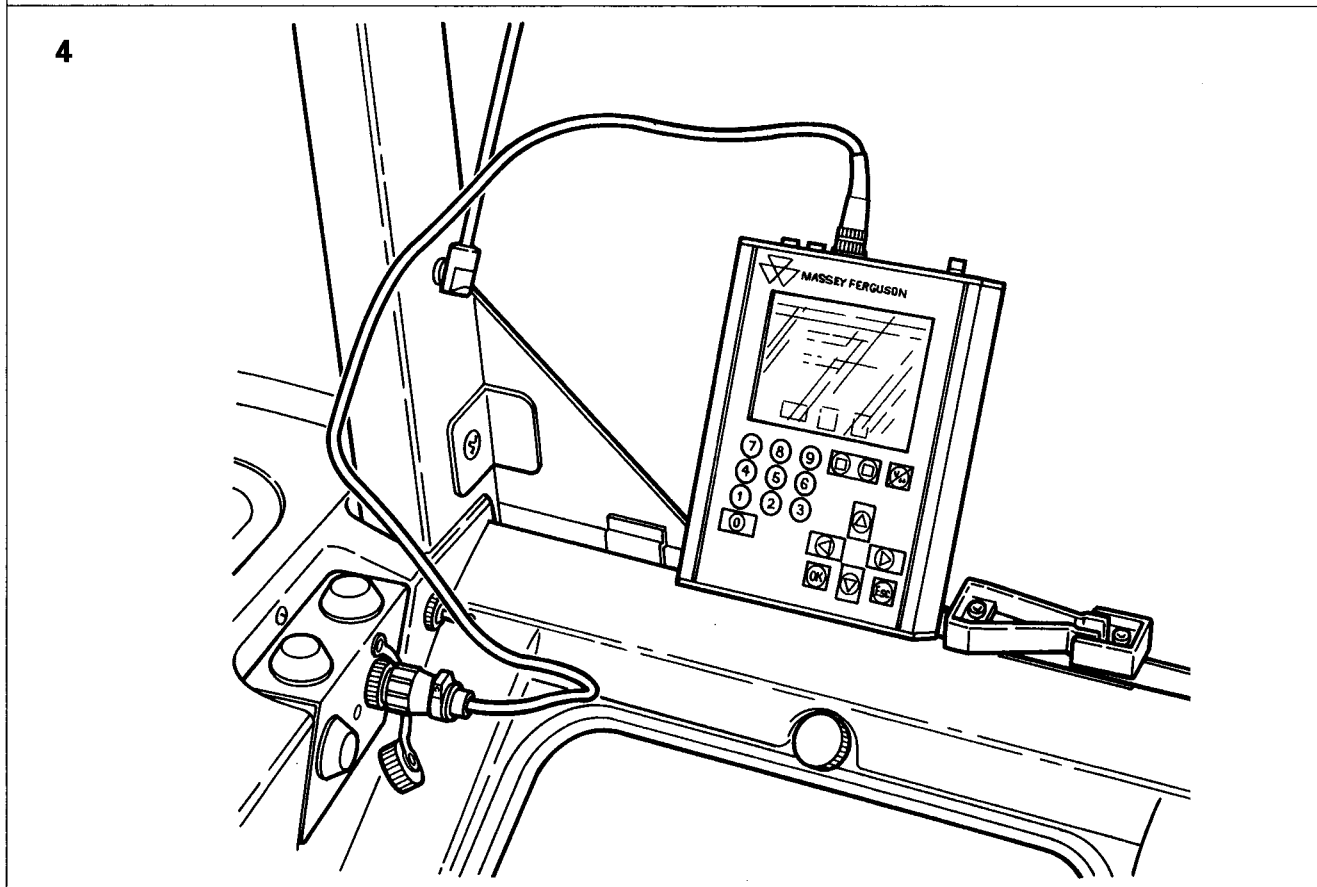
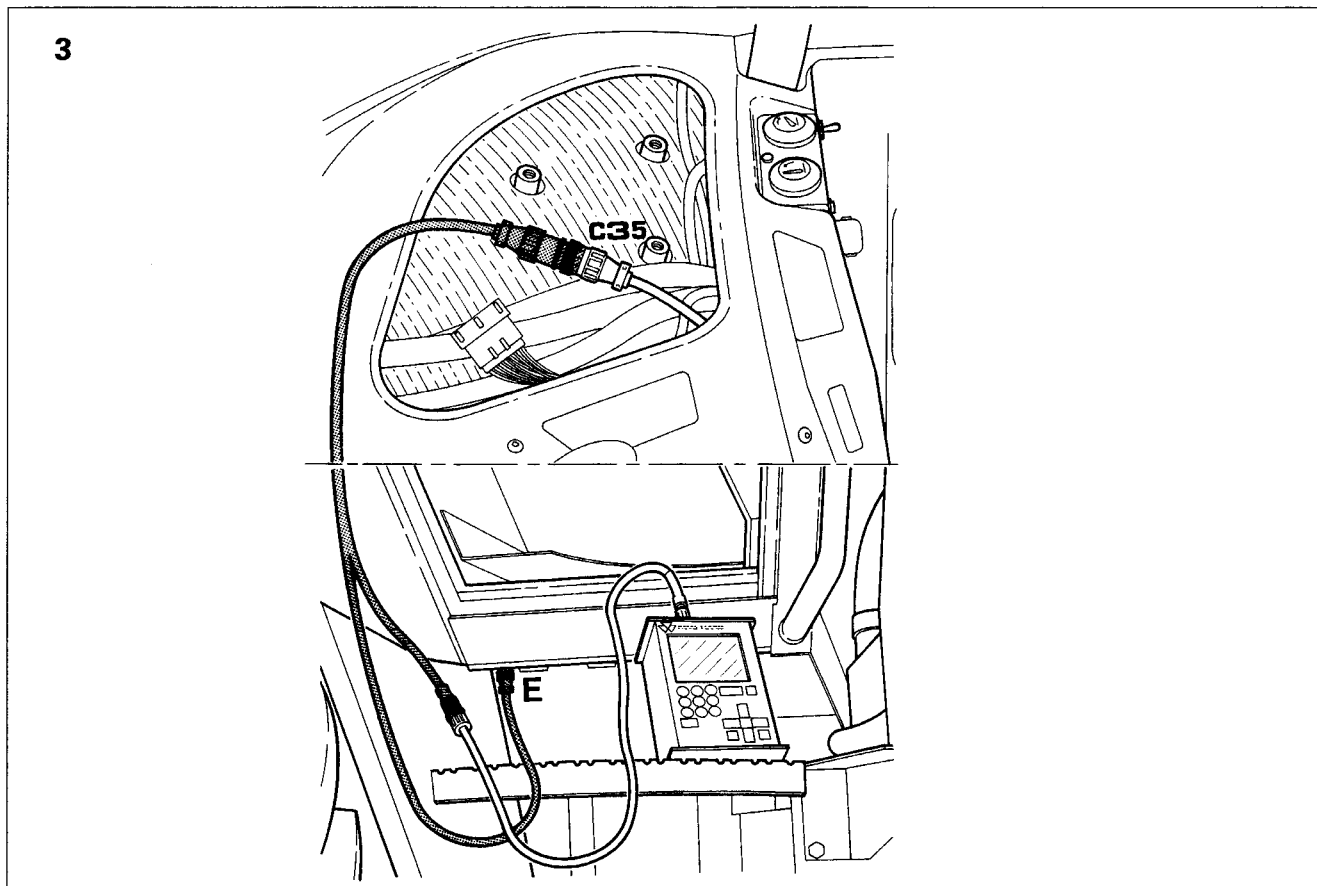



11A01.6

## 6100 SERIES TRACTORS

**Tester-programmer - Description****E. Screen displays**

Issue of operating software present on the tester-programmer.

Serial : 30101 - Indicates the tester serial number.

I: Identification of tester (see 12I01-2C)

Select the circuit to be tested using arrows and then press OK.

The tester indicates the ETCU operating software issue present in the tester (EX : issue Y).

Press the clutch to activate the ETCU.

The tester indicates the issue of the operating software of the tractor ETCU.

If the ETCU operating software issue is Y, press OK to go to the main menu.

**Case 1 - When the tester detects an ETCU software issue earlier than its own:**

The message «Program is necessary» is displayed on the screen.

Press OK to continue.

MASSEY FERGUSON  
(C) COPYRIGHT  
1993

PROM: A93121  
FLASH: A931210  
SERIAL: 30101

I xxxx

PRESS OK ■

**AUTOTRONIC**

**DATATRONIC**

**ELECTRONIC LINKAGE**

OK



**OPER. SOFT. ISSUES**

TESTER: Y

AUTOTRONIC: ?

PRESS CLUTCH PEDAL

TCU OFF

**OPER. SOFT. ISSUES**

TESTER : Y

AUTOTRONIC : Y-1

**PROGRAM IS NECESSARY**

PRESS OK ■





## **Tester-programmer - Description**

Start the engine to provide a power supply of more than 13.6 volts. This is required in order to clear the ETCU memory. Otherwise, a message is displayed on the screen.  
Press OK.

**PROGRAM TCU**

**START ENGINE**

**PRESS OK ■**

Disconnect the Autotronic black connector, **F**, to reset the ETCU.  
Press OK.

**PROGRAM TCU**

**DISCONNECT CONNECTOR F**

**PRESS OK ■**

Reconnect the Autotronic black connector, **F**.  
Press OK.

**PROGRAM TCU**

**CONNECT CONNECTOR F**

**PRESS OK ■**

Press the clutch pedal to activate the ETCU.  
Press OK.

**PROGRAM TCU**

**PRESS CLUTCH PEDAL**

**PRESS OK ■**



11A01.8

## 6100 SERIES TRACTORS

**Tester-programmer - Description**

It takes two minutes to clear the ETCU memory.  
Wait, without taking any action during this period (no indicator light on).  
If you make a mistake, disconnect connector **F** and then reconnect it. Then repeat the programming procedure.

**PROGRAM TCU****WAIT**

The tester reprograms the ETCU to obtain issue Y (indicator lights **B** and **C** or Speedshift Hi come on). Wait until the programming is completed (about five minutes).  
The value displayed on the screen switches from 32716 to 0.  
Then, lights **A, B, C, D** (or Speedshift Hi and Lo) come on.

**PROGRAM TCU****WAIT PROGRAMMING  
32716**

The transfer has been completed.  
The program was correctly transferred but the ETCU has not yet been initialised.  
Disconnect connector **F** on the ETCU to reset.  
Press OK.  
If a problem occurs during programming, only light **A** or **B** comes on. In this case, check the power supply and the connectors.  
Disconnect the ETCU and start again.

**PROGRAM TCU****WAIT PROGRAMMING  
0  
PROGRAM OK  
DISCONNECT CONNECTOR F****PRESS OK ■**

Reconnect connector **F** on the ETCU.  
Press OK.

**PROGRAM TCU****WAIT PROGRAMMING  
0  
PROGRAM OK  
DISCONNECT CONNECTOR F  
RECONNECT CONNECTOR F****PRESS OK ■**



## Tester-programmer - Description

### Case 2 :

The issues of the tester operating software and the ETCU are identical.  
No reprogramming is required.  
Press OK.

**OPER. SOFT. ISSUES**

TESTER :     **Y**  
AUTOTRONIC : **Y**

**PRESS OK** ■

The tester indicates the three possible functions:

- **Test** : to test the tractor circuit,
  - **Parameter** : to read or enter new parameters,
  - **Program** : to update the operating software issue.
- Select by moving the black line with the arrow keys.  
Press OK.

TCU: XX indicates the mode in which the ETCU is working (see section F). If the ETCU is switched off, press the clutch again.

**TEST**

**PARAMETER**  
**PROGRAM**

TCU: XX    **OK**    ▲    ▼    **ESC**

Parameter setting must be performed for each switch between issue **Y-1** and issue **Y** and when a new ETCU is installed.  
Press OK.

**TEST**

**PARAMETER**  
**PROGRAM**

**OK**    ▲    ▼    **ESC**

**OPER. SOFT. ISSUES**

TESTER :     **Y**  
AUTOTRONIC : **Y**

**PRESS OK** ■



11A01.10

# 6100 SERIES TRACTORS



## Tester-programmer - Description

### F . ETCU modes

In case of failure, it is important to note which mode the Autotronic ETCU is in.

The tester indicates the status of the Autotronic ETCU. This status, referred to as its mode, is identified by means of a code (TCU off, 1, 2, etc.) which is automatically displayed in the bottom left-hand corner of the screen.

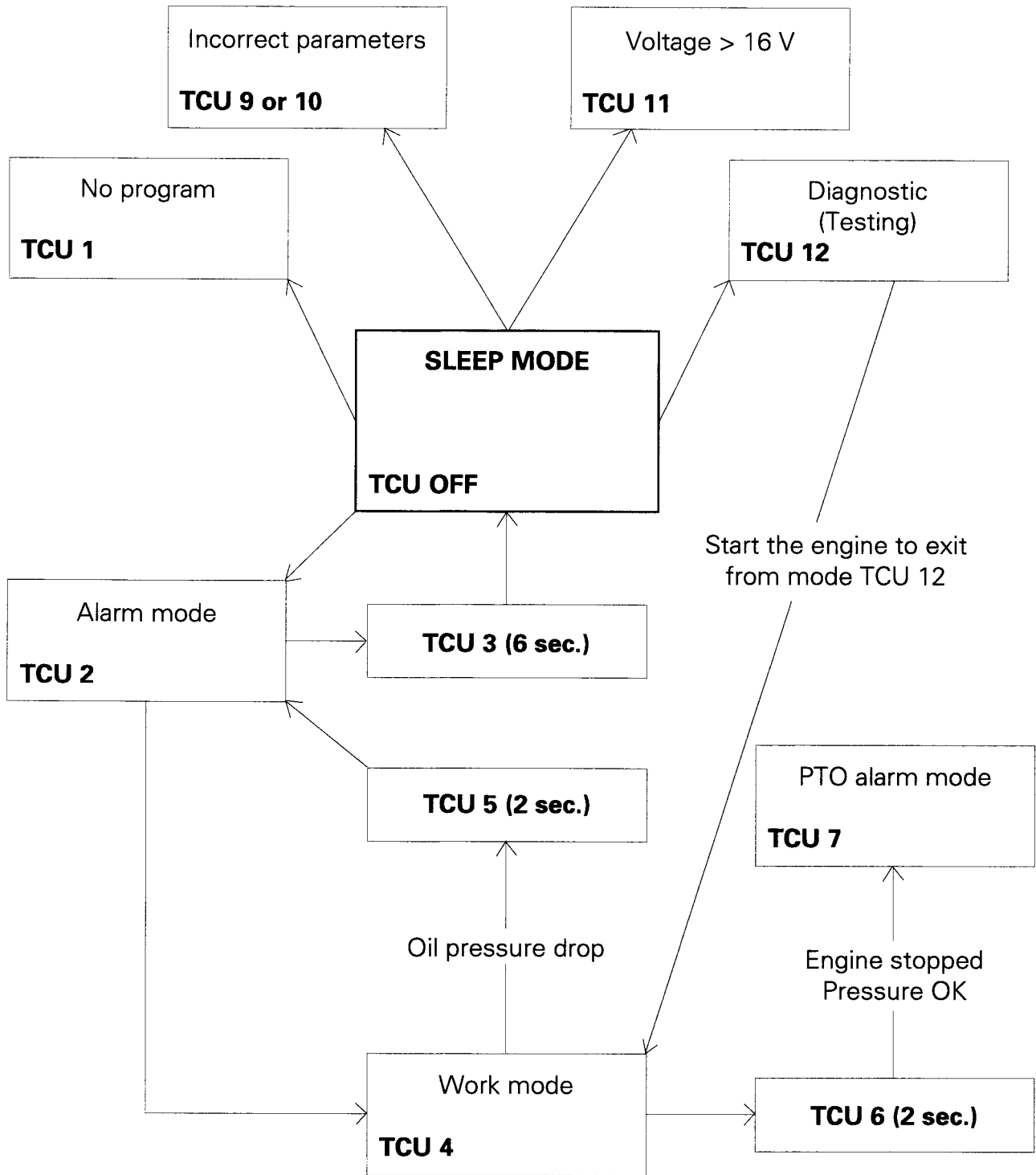



## Tester-programmer - Description

11A01.11

### G . Error messages

The tester can give the following error messages:

- Symbol**  **E100**
- E:1** Program error. Switch off and then on again.
- E:2** Parameter code too long. Check code on sticker in fuse box.
- E:3** No reference parameters found. Check code on sticker in fuse box.
- E:4** No 4WD parameters found. Check code on sticker in fuse box.
- E:5** No Hi/Lo (Hare/Tortoise) parameters found. Check code on sticker in fuse box.
- E:6** No gearbox parameters found. Check codes on sticker in fuse box.
- E:7** No speed limit parameters found. Check code on sticker in fuse box.
- E:8** No Speedshift parameters found. Check code on sticker in fuse box.
- E:9** No Dynashift parameters found. Check code on sticker in fuse box.
- E:10** Incorrect parameters (last 4 digits). Check code on sticker in fuse box.
- E:100** Voltage too low. Start engine. Check alternator. Min. 13 volts.
- E:101** Problem erasing TCU software. Check connections and try again.
- E:102** Problem locating new software in TCU. Check connections and try again.

### H . Multimeter function

From anywhere in the program, this function allows the following operations to be performed with a single test lead:

- measure a positive voltage using the tractor chassis as earth,
- measure earth continuity on the tractor,
- measure the frequency of speed sensor signals.

To access multimeter mode:

- Press key V/ + (10).
- Connect the test lead to plug 12 (**black**) to check earth continuity, or to plug 13 (**red**) to check voltage or frequency.

To exit from multimeter mode, press the ESCAPE key (8). The display on the tester screen returns to the state it was in when the multimeter function was selected.



**Do not use the tester to perform any measurements other than those specified.**

#### Resistance

The earth reference is on connector **C33**.  
(R = 0 Ω)

The screen display can be:

- R = -1 Ω when measuring the battery negative terminal for a low resistance on the line
- R = 0 Ω when measuring earth continuity with connector **C33**
- R = +1 or 0L for infinity or more than 30 Ω
- R = 1 to 30 Ω for resistance between 1 and 30 Ω

#### Frequency

Value in hertz = 0 to 4,000 Hz





*11A02 Reprogramming of the tester*

CONTENTS

<b>A. Equipment required</b>	_____	<b>2</b>
<b>B. Connecting the tester</b>	_____	<b>2</b>
<b>C. Tester identification</b>	_____	<b>2</b>
<b>D. Updating the tester</b>	_____	<b>3</b>
<b>E. Translating</b>	_____	<b>4</b>



**Note :** To perform procedures C, D and E basis knowledges of the DOS system are necessary.

## A . Equipment required

- 1 tester.
- 1 PC/tester connecting cable, ref. 3712344 M1.
- 1 mains power unit, 220 V - 12 V at 1 A (12.6 V min at 0.3 A).
- 1 PC IBM 386 or 286 Turbo compatible, serial port No 1 equipped with a 9-pin socket.
- 1 diskette containing the following files :  
Disc B:\ or A:\ (depending on the PC)

TRADUCT	EXE	.././95
FRANCAIS		.././95
BASE	TXT	.././95
TRADUCT	TXT	.././95
NAMETEST	TXT	.././95
TCU	HEX	.././95
TRANSFER	EXE	.././95
TRANSFER	TXT	.././95
TESTEUR	HEX	.././95
GERMAN		.././95
SPANISH		.././95
NAMETEST	EXE	.././95

## B . Connecting the tester

- Using cable 3712344 M1, connect the tester to the 12 V power supply (standard 3.5 mm jack plug).
- Switch on the tester. If it does not work, check the power supply or reverse the 12 V supply "+" and "-" leads.
- Switch off the tester.
- Connect the serial connector to port COM1 on the PC (9-pin socket).
- Switch on the tester and the PC.

## C . Tester identification

This procedure consists in replacing the message "SEGRE ELECTRONIQUE" displayed on the tester when it is switched on by the identification desired by the user.

- Start program NAMETEST.EXE on the PC in typing NAMETEST and then, press the "ENTER" key.  
Type you ID (20 characters maxi) ex : "SA.TRAC.OISE".  
Switch off the tester and then switch it back on.  
Your message is displayed instead of "SEGRE ELECTRONIQUE".

**Note :** File NAMETEST.EXE is the program used to change the tester identification.

**File NAMETEST.TXT is the file containing the messages for the NAMETEST program.**





## D . Updating the tester

This operation consists in replacing the whole tester program if you want to :

- enter a new version of the tester program,
- enter a new version of the TCU program in the tester,
- change the tester language.

### Procedure

- Connect the tester to the power supply and to the PC as specified in part B.
- Switch on the tester and the PC.
- Type the following message and then press the "ENTER" key
  - to transfer English, type TRANSFER
  - to transfer French, type TRANSFER FRANCAIS
  - to transfer German, type TRANSFER GERMAN
  - to transfer Spanish, type TRANSFER SPANISH

**Caution : This program will transfer the following to the tester :**

- **the tester program (file TESTEUR.HEX)**
- **the TCU program (file TCU.HEX)**
- **the tester language FRENCH or GERMAN or SPANISH or other (see E).**

The transfer takes about 8 minutes.

- When the operation has been completed, switch off the tester and then switch it on again.

### Error messages

The messages are listed in **'ERREUR.TXT'**. Use the DOS function "TYPE" to read them.

**ERROR 1** : problem on serie port of PC (COM1).

**ERROR 2 to 7** : dialog problem

**ERROR 8** : loading problem (PC microprocessor speed)

**ERROR 9** : dialog problem

**ERROR 10** : no answer from tester (reboot tester)

**ERROR 11 and 12** : dialog problem

**ERROR 13 and 14** : problem on files to transfer (check disc)

**ERROR 15** : dialog problem

**ERROR 16 and 17** : problem of tester identification

**ERROR 18 and 19** : too low tester supply

**ERROR 20** : supplier test problem

If an error message appears, check connections, supply stability, PC compatibility.

Switch the tester OFF, then ON to reboot and start again : TRANSFER.

If the problem appears again, contact Beauvais Service.



## E . Translating

This procedure consists in creating a new file containing the messages displayed on the tester

The new messages can be displayed in another language.

- Start the TRADUCT program on the PC, for example :

To translate into another language (ex : ITALIAN)

Type "TRADUCT ITALIAN"

A file "ITALIAN" will be created to store the italian translation you will enter.

If the file "ITALIAN" already exists, you will be asked if you want to modify it.

Then, a temporary file TEMP.XXX will be created.

The english text appears on the screen. Type the translation line per line using 20 characters maxi for each of them.

It is necessary to type the blanks to centralise the text and to cover the existing letters.

In case of a mistake, finish the translation to exit. Re-enter the same file with TRADUCT.EXE.

Use "RETURN" to go down to the faulty line. Press any key to erase it. Type the correct text.

Use "RETURN" to go to the end and exit.

- The new language file (Italian) is ready to be introduced in the tester. Use the procedure updating the tester (part D) by typing TRANSFER ITALIAN.

### Tester language to translate (English version)

```

* AUTOTRONIC *
* TEST *
* PARAMETER *
* PROGRAM *
* CODE *
* CODE OK ? *
* PROGRAM TCU *
* PUT AUTOTRONIC OFF *
* PRESS CLUTCH PEDAL «
* WAIT *
* WAIT PROGRAMMING *
* PROGRAM OK ! *
* DISCONNECT *
* CONNECT *
* POWER CONNECTOR F *
* OPER.SOFT ISSUES *
* TESTER *
* PROGRAM IS NECESSARY *
* PROGRAM TCU *
* OPER.SOFT ISSUE OK *
* NOT NECESSARY *
* CONFIRM PROGRAM ? *
* OPER.SOFT *
* NOT *
* COMPATIBLE *
* START ENGINE *
* MONITORING *
* TESTING *
* DATATRONIC *
*
*
*
*
*ENGINE RPM*
*PTO 540 *

```

### New language to introduce



6100 SERIES TRACTORS



Tester-programmer - Reprogramming

11A02.5

Tester language to translate (English version)

New language to introduce

- \*PTO 1000 .
- \*FWD SPEED .
- \*WHEEL SLIP .
- \*SLIP LIMIT .
- \*AREA/HOUR .
- \*FUEL/HOUR .
- \*FUEL/AREA .
- \*COST/AREA .
- \*FUEL USED .
- \*AREAWORKED
- \*DISTANCE .
- \*HRS WORKED
- \*COUNTER .
- \*COMP.MODE
- \*EXT.TEMP. .
- \*TIME .
- \*DATE .
- \*SERVICE .
- \*FUEL/COST .
- \*COST/HOUR
- \*METRIC/IMP
- . .
- . .
- . .
- . .
- \*METRIC .
- \*US IMPER. .
- \*UK IMPER. .
- . .
- . .
- . .
- \*WORKING WIDTH .
- \*AREA WORKED .
- \*DISTANCE .
- \*FUEL USED .
- \*HOURS WORKED .
- \*COUNTER .
- . .
- . .
- . .





*11 B01 Description of electronic lift control*

CONTENTS

<b>A.</b>	<b>Description</b> _____	<b>2</b>
<b>B.</b>	<b>Control panel</b> _____	<b>4</b>



11B01.2

# 6100 SERIES TRACTORS



## Electronics - Lift control

### A. Description

The electronic lift control system (Fig. 1) is made up of the following components:

- a control panel (1),
- a digital computer (2),
- a position sensor (3),

- two draft sensors (4),
- an electrical harness (5),
- a proportional control electrohydraulic control valve (6),
- four or six external control switches (according to option) (7).

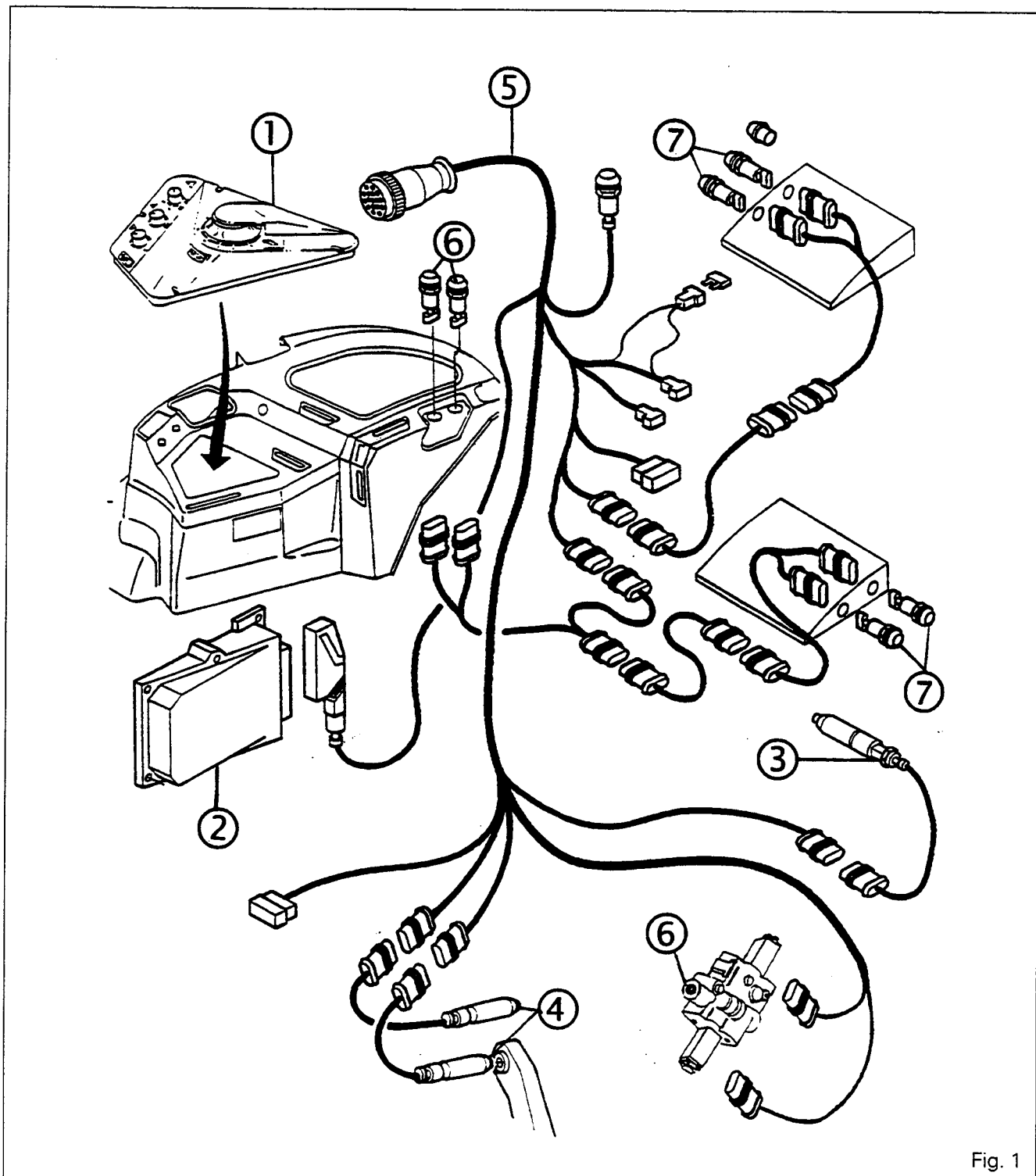

Fig. 1



## **Electronics - Lift control**

### **(1) Control panel**

Located on the right-hand side in the cab, the control panel comprises:

- four potentiometers,
- a switch,
- a push-button,
- five warning lights.

### **(2) Electronic computer**

This is installed on the right-hand side in the cab, under the lift control panel.

The computer records the signals sent out from the various controls on the control panel and compares them with the signals transmitted by the sensors. If these two types of signal have different values, the computer transmits its own signals to the lift control valve solenoids. This signal causes the lift arms to be raised or lowered until the values set on the control panel are equal to those received from the sensors.

When the tractor is working, these corrections are made continuously to ensure optimum work quality.

#### **Safety:**

The system is equipped with a safety device that prevents the electronic system from being active when the engine is stopped.

When the ignition is switched on, the computer is supplied with 12-volt power from the starter contactor. This lights up the three warning lights, **I**, **J** and **K**.

Lights **K** and **J** come on for 0.5 second.

Light **I** remains eliminated until the «engine running» signal is received from the alternator and the raising/lowering switch is set to position 1, then lowering position 2.

**Warning: Set position monitoring by positioning knob B to 1.**

### **(3) Position sensor**

The position sensor is installed on the auxiliary spool valve support to the rear of the tractor. It is positioned in contact with a cam on the arm lift actuating shaft. The sensor registers the angular position of the lift actuating shaft and sends the data to the lift control computer.

### **(4) Draft sensors**

These two sensors are fitted on the hitch links at their articulation with the lower support.

They convert the loads exerted on the hitch links during work operations into electrical signals.

Those signals are transmitted to the lift control computer.

### **(5) Electric harness linking the various components**

### **(6) Electrohydraulic control valve**

This is fitted on the auxiliary spool valve support to the rear of the tractor.

Its function is to regulate the oil flow so that the lift arms are raised or lowered in accordance with the signals transmitted by the computer and received by the two solenoids. The control valve is installed on the high-pressure (high-flow) hydraulic system.

### **(7) External control switches**

These are located on the fenders or in the cab, according to the relevant specifications. They are designed to simplify the coupling of certain implements by allowing the operator to control the height of the implement.

The switches can be used if the control panel is activated and the raising/neutral/lowering switch is set to the neutral or lowering position.

For safety reasons, the lift controls in the cab are automatically switched off when the external control switches are used.

To return control of lifting operations to the control panel in the cab, switch **E** must be moved to the raising position.



11B01.4

## 6100 SERIES TRACTORS

**Electronics - Lift control**

Fig. 2

**B. Control panel****Designation of controls**

- A. Height/depth setting
  - B. Function selector (draft, mixing, position)
  - C. Maximum lift limiter (setting of high position)
  - D. Setting of manual or automatic lowering speed and locking position (padlock) or automatic control
  - E. Raising/neutral/lowering
    - Raising or transport: the high position is defined by adjusting knob C.
  - F. Transport control selector push-button
  - G. Arm lifting warning light
  - H. Arm lowering warning light
  - I. Control panel locking warning light and self-diagnosis of operating failures
  - J. Transport control selector warning light
  - K. Lowering speed automatic control warning light
- Neutral or stop: no movement of the lift arms is possible in this position.
  - Lowering or work position: the low position obtained is defined by the settings of selectors A and B.



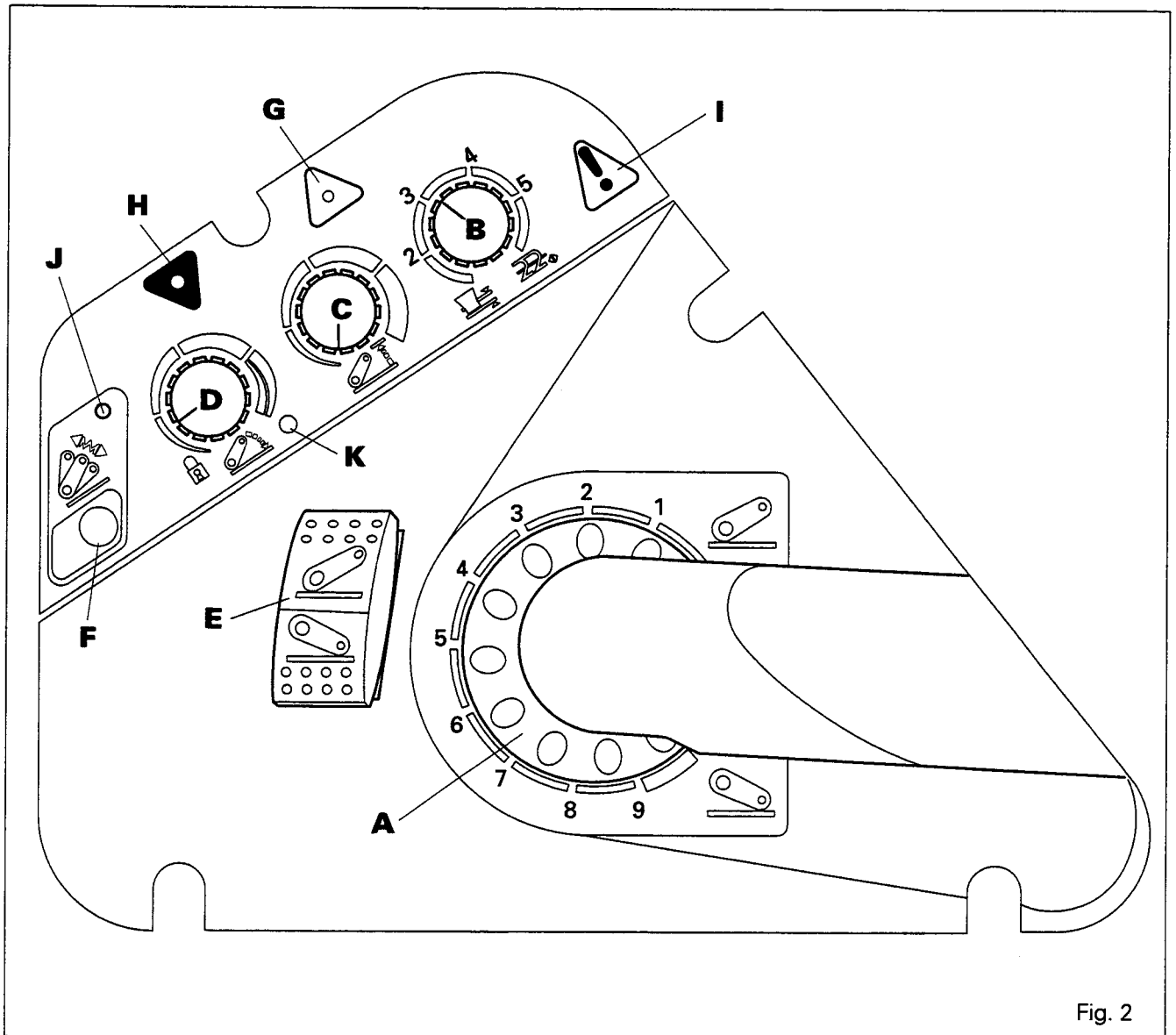

## Electronics - Lift control

### Description of controls

#### A. Height/depth setting potentiometer

This potentiometer **A** must be adjusted to set the depth (or height) of the instrument once the function selector **B** has been selected.

In position control mode, the potentiometer travel is maximum.

The maximum high position is slightly higher when it is obtained using external controls than when using the potentiometer **A**.

The floating position can be obtained by setting the potentiometer **A** to 9. In this case, the lowering warning light remains on.

#### B. Function selector potentiometer (draft/intermix/position)

This potentiometer must be set according to the work to be done:

- Position control: to be used for carried implements.
- Draft control: to be used for implements entering the soil (rarely used in 100% control).
- Intermix: to be used with implements entering the soil in order to control the maximum draft while maintaining even depth (position most commonly used for ploughing, subsoil work, etc.).

#### C. High position potentiometer

This potentiometer is used to set the maximum height of the lift arms.

When the switch, **E**, is in the raising position, the lift arms are raised until they reach the adjustment value selected by the high position potentiometer, **C**.

#### D. Lowering speed potentiometer

This potentiometer is used to adjust the implement lowering speed when lowering is selected on switch **E**. The potentiometer operates in the following three modes:

- Locked position: when the potentiometer is in the maximum anticlockwise position, the lift control cannot be lowered (transport safety device).
- Automatic speed position: when the potentiometer is in the maximum clockwise position, the speed is automatically adjusted according to the weight of the implement (measured by the draft sensors in the high position) and the tractor speed (measured by the tractor speed sensor connected to the Autotronic system). When this automatic speed mode is selected, warning light **K** is illuminated.

#### E. Raising/neutral/lowering switch

This switch allows work in the following three modes:

- Raising or transport position: the implement is raised until the maximum position selected by potentiometer **C** is reached.
- Neutral position: the implement is locked in its current position. This setting must not be used during the work phase.
- Lowering or work position: the instrument is lowered until it reaches the position selected on the depth potentiometer **A** and the function selector potentiometer **B**.

**Note: When restarting or after using the external controls, switch E must be set to the lifting position in order to activate the system.**

#### F. Transport control selector push-button

This push-button must be pressed once in order to be activated when switch **E** is in the transport position. In this case, each time that switch **E** is set to the transport position, the electronic computer energises the lift valve solenoids in order to keep the implement stable whatever the tractor speed.

The system is automatically disengaged when switch **E** is in the work position.

Warning light **J** is illuminated when the system is active in the transport position.

To deactivate this function, the lift control must be set to the transport position and push-button **F** must be pressed twice.

#### G - H. Arm raising and lowering warning lights

The warning lights come on at exactly the same time that the solenoids are energised. They indicate that the system is operating correctly.

Their status changes continually when the lift control is used in draft control mode or in slip control mode.

#### I - J - K. Warning lights indicating corresponding functions





**Electronics** - Lift control electrical system

11B02.1

*11 B02 Lift control electrical system*

CONTENTS

A. Description \_\_\_\_\_ 2



11B02.2

## 6100 SERIES TRACTORS

**Electronics - Lift control electrical system****A. Description**

The electrical system is made up of the following components:

1. Start switch
2. Lift control panel lighting
3. Alternator
4. Battery
5. Autotronic unit
6. Radar
7. Tractor computer (Datatronic)
8. Engine speed sensor (Autotronic 2 speed output)
9. Forward speed sensor (Autotronic 2 speed output)
10. Lift control valve
11. Left-hand draft sensor
12. Right-hand draft sensor
13. Position sensor
- 14-15. External control buttons
16. Third set of external or internal controls for automatic hook
17. Lift control computer

**Identification of terminals on lift control computer connector M**

1. Earth for sensors
2. 9.5 V power supply for sensors
3. Engine speed signal
4. Slip control signal
5. Not used
6. +12 V after contact
7. Position sensor signal
8. Depth potentiometer signal
9. Battery earth
10. Battery +12 V
11. Not used
12. Lighting +12 V
13. Automatic lowering warning light
14. CAN H. (connected to 15)
15. CAN H.
16. Alternator engine running signal (D+)
17. Not used
18. Not used
19. Lowering solenoid
20. Lift control panel earth
21. Not used
22. Earth
23. Ground speed signal
24. Forward speed signal
25. Right-hand draft signal
26. Intermix
27. Lowering speed
28. External controls, raising/lowering
29. Not used
30. Not used
31. Not used
32. Transport control warning light
33. CAN L. (connected to 34)
34. CAN L.
35. «CAN» network earth
36. Not used
37. Not used
38. Not used
39. Control panel 9.5 V power supply
40. Not used
41. Earth
42. Earth
43. Left-hand draft signal
44. High position signal
45. Battery earth
46. Raising/neutral/lowering switch
47. Battery +12 V
48. Not used
49. Diagnostic warning light
50. Not used
51. Transport control switch
52. Not used
53. Power supply to solenoids
54. Not used
55. Raising solenoid

**Identification of connections**

Item	Colour	Ways	Description
A	White	5	General power supply - connector C14
B	Black	4	«CAN» network
C	White	2	«Autotronic» high position signal connector C35
D	Black	7	Datatronic speed signals
E	Black	5	Forward speed and engine speed signals - connector C36
F	Yellow	2	Lowering solenoid valve
G	Black	2	Raising solenoid valve
H	Grey	3	Left-hand draft sensor
I	Grey	3	Right-hand draft sensor
J	Black	3	Position sensor
K	Black	3	External controls
K1	Black	3	External controls
K2	Black	3	External controls
K3	Black	3	External controls
K4	Black	3	External controls
K5	Black	3	External controls
L	Round	37	Lift control panel connection
M	Black	55	Computer connection

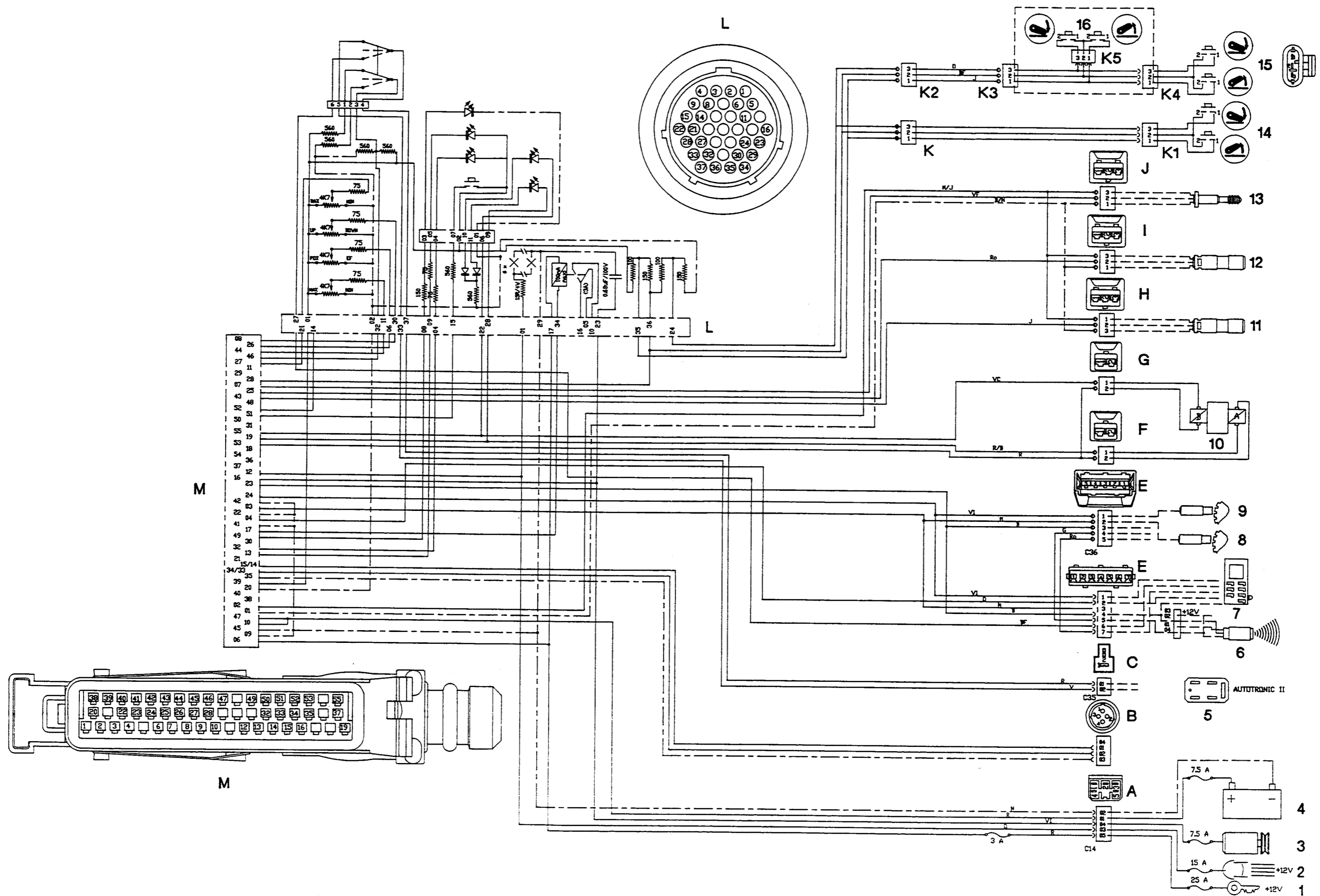



11B02.4

---

**6100 SERIES TRACTORS**

---

**Electronics - Lift control electrical system**

**The lift control panel** is equipped with a 37-way round connector and a printed circuit soldered onto the potentiometers and other components (resistors). Two connectors are located under the control panel: the raising/neutral/lowering switch harness and the warning lights harness.

The main output signals are signals from the potentiometers (depth, intermix, maximum height, lowering speed), the signal from the raising/neutral/lowering switch (via resistors: earth = lower, voltage = raise), the signal from the transport control button and the signal from the computer external controls.

**External controls**

Three sets of external controls can be fitted. They are connected to a set of resistors installed on the printed circuit. There is a single line to the computer for the raising and lowering signal.

**The electronic lift control computer** is equipped with a 55-way connector (see page 2).

Certain connections are not used in the standard application.

The computer is supplied with power by the battery. It is protected by a 7.5 A fuse located under the air filter, a 25 A fuse located in the fuse box and a 3 A fuse located under the lift control panel.

The computer is earthed by means of a wire on the gearbox selector cover.

To prevent the lift control system being active when the engine is running, a safety system is installed, managed by the computer (see Section 11B01, Part B).

The computer supplies the sensors (position and draft) and the lift control panel (potentiometers and switches) with 9.5-volt power.

It receives signals from:

- the position sensor,
- the draft sensors,
- the sensors for engine speed and theoretical forward speed via the Autotronic system (the forward speed being necessary for management of the lowering speed),
- the radar,
- the Datatronic system (slip control).

**Note: The raising/neutral/lowering switch on the control panel is connected to the Autotronic unit and to the Datatronic unit (so that the Datatronic system can count the hours and area worked).**

**Terminals of lift control panel connector**

No.	Description
1.	+12 volts - Lighting
2.	Earth for potentiometers and switches
3.	9.5-volt power supply
4.	Power supply to transport control warning light
5.	Not used
6.	Intermix potentiometer signal
7.	Not used
8.	Power supply to diagnostic warning light
9.	Power supply to automatic lowering speed warning light
10.	Not used
11.	High position potentiometer signal
12.	Not used
13.	Not used
14.	Not used
15.	Transport control selector push-button signal
16.	Not used
17.	Not used
18.	Not used
19.	Not used
20.	Not used
21.	Lowering speed potentiometer signal
22.	Power supply to raising indicator light
23.	Power supply + engine running
24.	Power supply to lowering external controls
25.	Not used
26.	Not used
27.	Work position signal for Datatronic (from raising/neutral/lowering switch)
28.	Power supply to lowering warning light
29.	Earth for warning lights, lamps and capacitor
30.	Depth potentiometer signal
31.	Not used
32.	Signal from raising/neutral/lowering switch
33.	Transport position signal for Autotronic (from raising/neutral/lowering switch)
34.	Not used
35.	Power supply to raising external controls
36.	Signal for external control
37.	+12 volts after contact for Autotronic signal



**Electronics - Lift control electrical system**

11B02.5

Block Diagram of data received and supplied by lift control computer

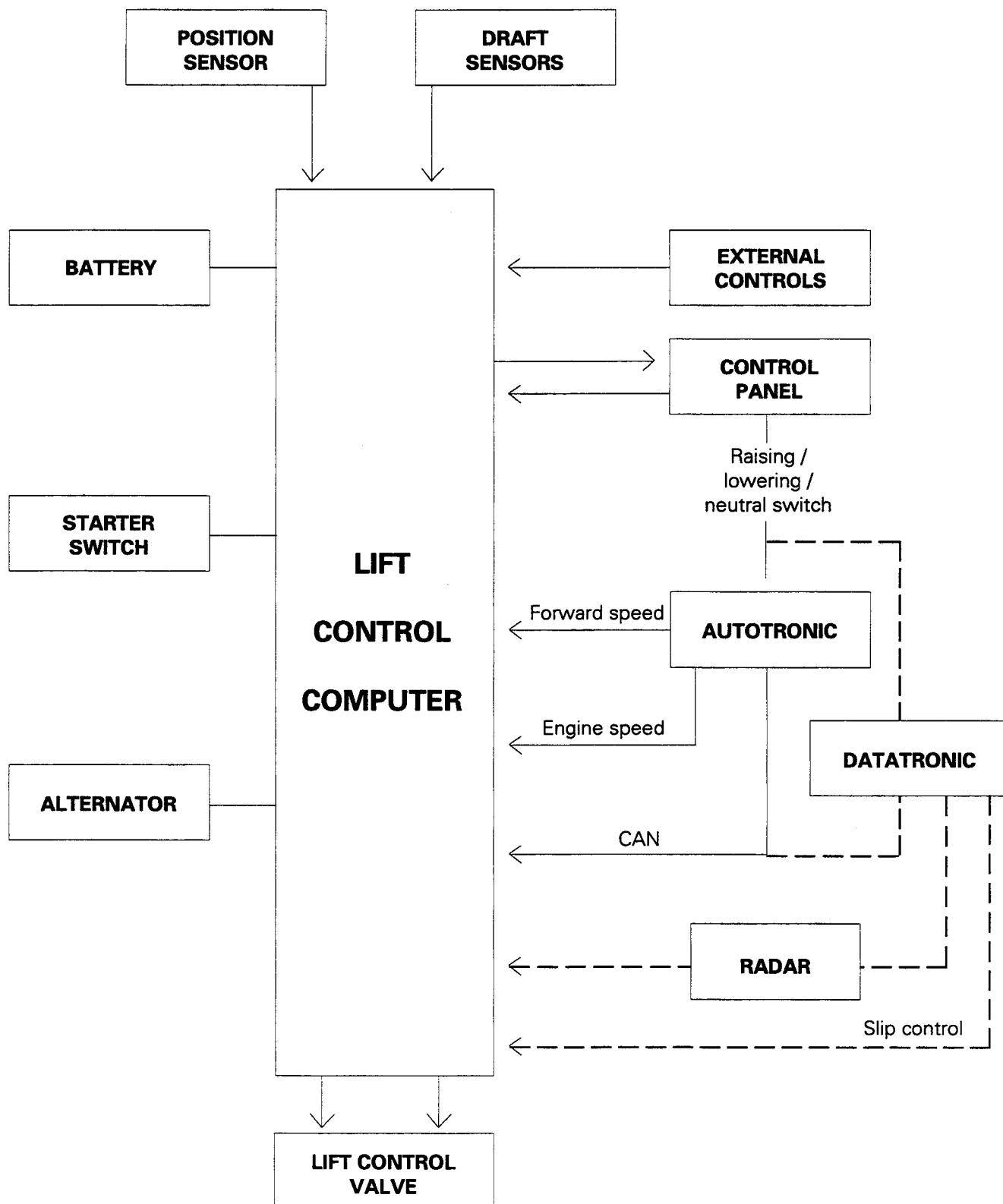







*11B03 Auto-diagnostic*

COTENTS

A. **Operation** \_\_\_\_\_ 2



11B03.2

## 6100 SERIES TRACTORS

**Electronic lift control - Auto-diagnostic****A . Operation**

The electronic lift control calculator is able to detect some faults on the harness or the components. When a fault has been detected, the driver will be informed by the flashing of the warning light I on the ELC control panel.

The first number of the flashing sequence indicated the importance level of the failure (1 = important, 2 = average, 3 = minor)

Code	Fault	System reaction	Action
1 - 1	One solenoid unplugged	Supply of solenoids interrupted No movement permitted	Interrupt supply. Repair fault. Reconnect supply to reset.
1 - 2	Short on lift solenoid	Idem	Idem
1 - 3	Short on lowering solenoid	Idem	Idem
1 - 5	Problem on external controls	Idem	Idem
1 - 6	Supply : more than 18 V	Idem	Idem
1 - 7	Short on 9.5 V line	Idem	Idem
1 - 8	Problem on lift/Lowering switch	Idem	Idem
2 - 2	Problem on position sensor	Console locked. Non control active.	Repair fault. Reset by putting Lift/ Lowering switch on lift.
2 - 3	Problem on depth potentiometer	Idem	Idem
2 - 4	Problem on maxi height potentiometer	Idem	Idem
2 - 7	Supply : less than 10 V	Idem	Idem
3 - 1	Problem on R.h.s. draft sensor	System working but diagnostic light flashing.	Idem
3 - 2	Problem on L.h.s. draft sensor	Idem	Idem
3 - 4	Problem on drop speed potentiometer	System working but diagnostic light falshing. Automatic drop speed selected.	Idem
3 - 6	Problem on intermix potentiometer	System working but diagnostic light flashing.	Idem



**Electronics** - *Electronic lift control*

*11 B04 Checking with tester*

CONTENTS

<b>A. General</b>	_____	<b>2</b>
<b>B. Symbols (icons)</b>	_____	<b>2</b>
<b>C. Connections</b>	_____	<b>2</b>
<b>D. Procedure</b>	_____	<b>2</b>
<b>E. Monitoring</b>	_____	<b>3</b>
<b>F. Adjusting the position sensor</b>	_____	<b>8</b>



11B04.2

## 6100 SERIES TRACTORS

**Electronics - Electronic lift control****A. General**

The tester is used to trace failures in the event of faulty operation of the lift linkage whether it is recognised by the diagnostic indicator light or not.

To carry out the test: START THE ENGINE.

The **monitoring** and **position sensor adjustment** functions are then accessible.

**B. Symbols (icons)**

As in the case of the Autotronic unit, the ELC functions are identified by the following icons:

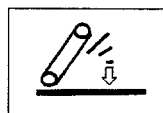

Lowering speed

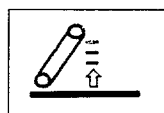

High position

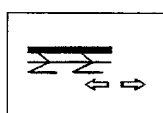

Draft

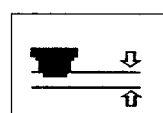

Position

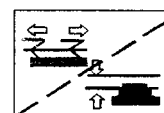

Intermix

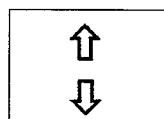
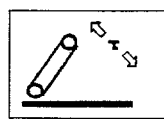
Lifting  
Lowering

Damper



Fault

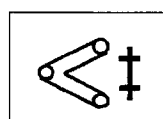

Depth

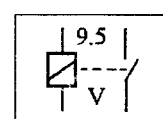

Relay

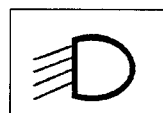

Lighting

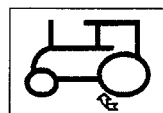

Wheel slip

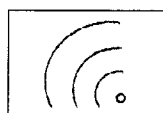

Radar

**C. Connection (see 11 A01)**

- Use connection No. 3 for tractors not equipped with Datatronic.
- Use connection No. 4 for tractors equipped with Datatronic.

**D. Procedure****- Tracing a fault code**

If more than one failure occurs at the same time, it may be difficult to visually decode the auto-diagnostic indicator light I on the console.

In these conditions, the «MONITORING» function can be used to identify the code or codes generated by the indicator light. The code is displayed in clear mode under the symbol corresponding to the auto-diagnostic indicator light.

Example:

Code 22 - Fault  
on position sensor



22

**- Precise tracing of a fault**

The code generated by the auto-diagnostic system has been translated and you want to carry out a precision check on a component, such as a potentiometer. The first monitoring screen allows you to view all the components of the console along with the corresponding values of the feedback signals. The second screen is used to monitor all the analogue inputs: battery voltage, signals from effort and position sensors, state of the internal safety relay.

The third screen is dedicated to external controls and the fourth to frequency inputs, i.e.: engine speed, forward speed (radar), theoretical forward speed (sensor) and MAX wheel slip value.

**- Adjusting the position sensor**

If, during servicing, it is necessary to check the adjustment of the position sensor or to fit a replacement sensor, the tester proposes the following section: position sensor adjustment. When this function is called, the tester indicates whether the position sensor is correctly adjusted or not and, if it is incorrectly adjusted, it indicates whether the adjustment value is to be decreased or increased.

In all cases, the message «OK» is displayed on the screen as soon as the sensor is correctly adjusted.



## 6100 SERIES TRACTORS



### **Electronics** - *Electronic lift control*

11B04.3

This screen is used to select the circuit to be tested.

Use the cursor arrow keys to position the grey bar on ELECTRONIC LINKAGE.

Press OK.

**AUTOTRONIC**

**DATATRONIC**

**ELECTRONIC LINKAGE**

OK

 ▲
 

 ▼

If the ignition is on but the engine is not running, the screen only appears if AUTO II is activated. Press the clutch pedal: the tester displays its operating software issue number and that of the lift control computer.

Press OK.

**OPER. SOFT. ISSUES**

<b>TESTER</b>	:	2.1
<b>LINKAGE</b>	:	1.0

OK
ESC

### **E . Monitoring**

The tester offers the following choice: Monitoring, Sensor adjustment.

Select «MONITORING».

Press OK.

**MONITORING**

**SENSOR ADJUSTMENT**

OK

 ▲
 

 ▼
 
ESC



11B04.4

## 6100 SERIES TRACTORS

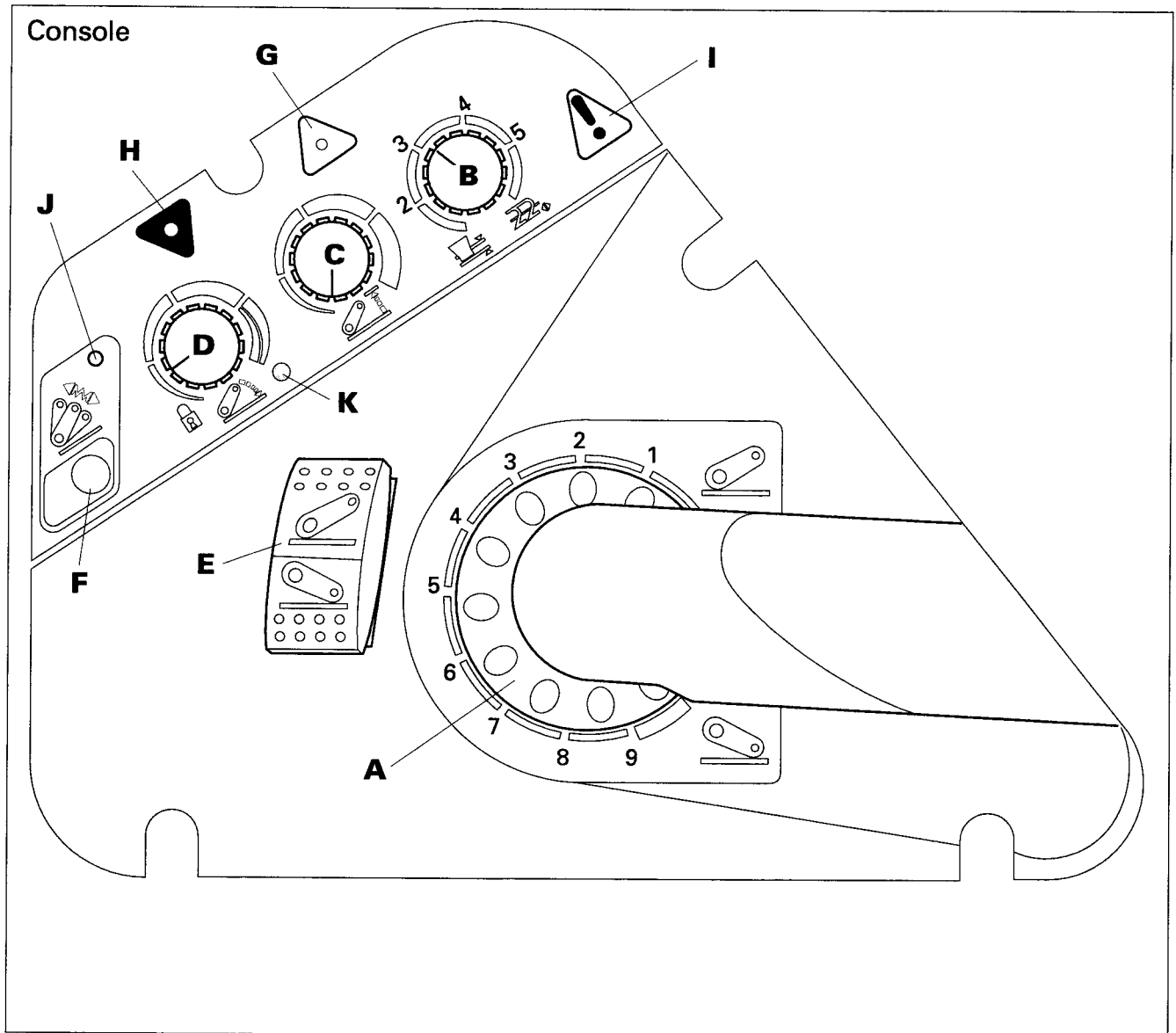
**Electronics - Electronic lift control**

- (D) Lowering speed potentiometer
- (K) Automatic lowering LED
- (C) High position potentiometer
- (B) Intermix potentiometer
- (A) Depth potentiometer
- (E) Lifting / Neutral / Lowering switch
- (H and G) Lifting and Lowering indicator lights
- (J) Transport impact damper indicator light
- (F) Impact damper control button
- (I) Auto-diagnostic indicator light

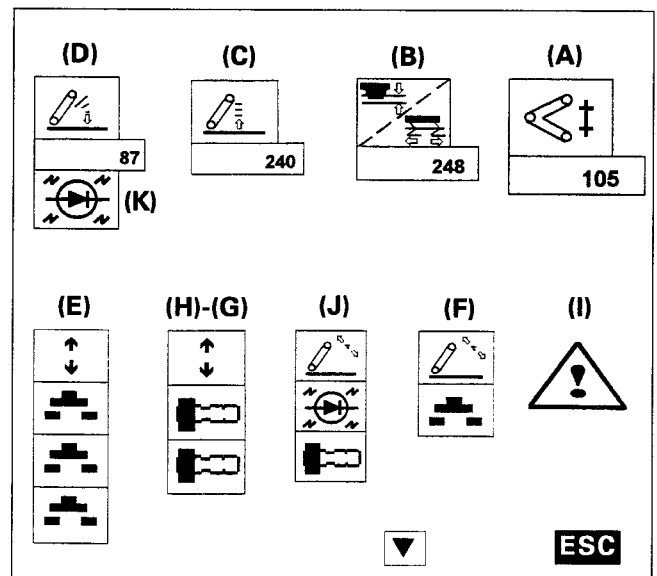



## Electronics - Electronic lift control

**1 . Lowering speed potentiometer (D)** (between 1 and 248, fault at 254) with an LED signalling the automatic earthing function (K).

Graduation	Approximate value
1	50
2	130
3	200

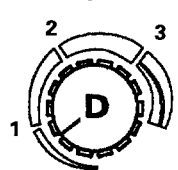

**2 . High potentiometer (C)** (between 79 and 240, fault at 255). The high position potentiometer cannot give a lower value than that on the position sensor. To test the whole range of values, set the lift control to the MAX. LOW position.

Graduation	Approximate value
1	119
2	169
3	216

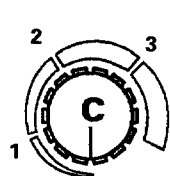

**3 . Intermix potentiometer (B)** (pure effort at 1, pure position at 248 and fault at 254).

Graduation	Approximate value
1	248
2	211
3	158
4	100
5	42
6	1

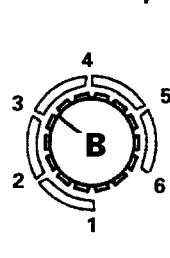

**4 . Depth potentiometer (A)** (between 11 and 249, fault at 255).

Graduation	Approximate value
0	249
1	226
2	202
3	178
4	156
5	130
6	104
7	80
8	55
9	29

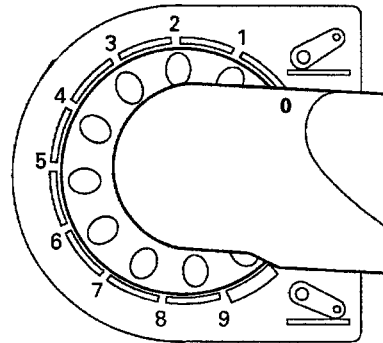

**5 . Lifting / neutral / lowering switch (E)**. The three contactors shown under the icon correspond to the three positions of the switch. According to the switch position, the icons change to reverse video (change of state) one after the other.

**6 . Lifting / lowering solenoid valve**. Start the engine and operate switch **E**. The solenoid valve indicator lights **H - G** on the tester change to reverse video (change of state) as soon as the lift control is activated either in lifting or lowering mode.

The corresponding indicator lights are illuminated on the console as soon as the switch is placed to the lifting or lowering position.

**7 . Transport damper indicator light (J)**. This changes to reverse video on the screen when the damper button is pressed and the Lifting / Lowering switch is in the high position.

**8 . Damper control button (F)**. This changes to reverse video when the button is pressed.

**9 . AUTO DIAGNOSTIC indicator light (I)**. The fault code detected by the auto-diagnostic system is shown under this icon.



11B04.6

## 6100 SERIES TRACTORS

**Electronics - Electronic lift control****Analog inputs**

From the console elements monitoring screen, press



to go to the «Analog inputs» screen.

**1 . Value of right and left draft sensor**

166 when sensor not fitted, fault 255.

**2 . Value of position sensor**

235 in high position.

**3 . Value of battery voltage**

ERR displayed for abnormal voltage.

**4 . State of internal safety relay**

This controls the 9.5 V voltage for the analog inputs. If no 9.5 V is present (icon displayed in normal video mode), all the analog input values (sensors, potentiometers and states of control buttons) are cleared as they no longer have any significant meaning and the power stages (outputs to solenoid valves) can no longer be operated.

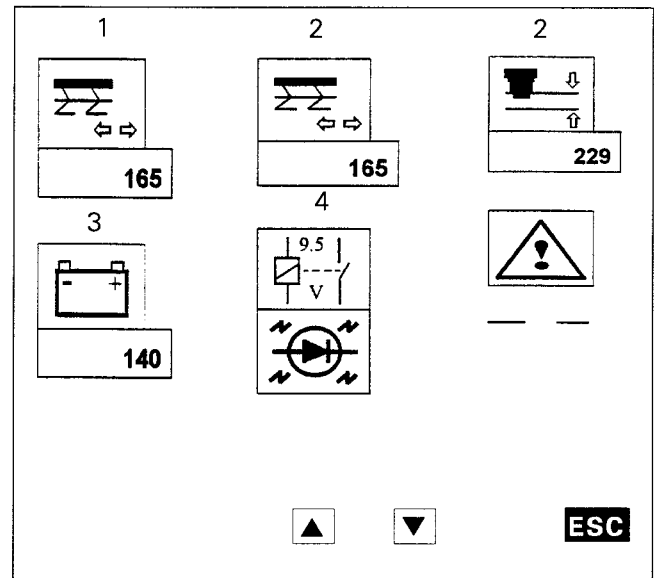
**External controls**

From the analog input monitoring screen, press



to display the «External controls» screen.

**1 . Information + Engine running**

Icon in reverse video if + engine running present.

**2 . State of lifting and lowering external controls**

The corresponding icon changes to reverse video when the button is pressed.

**3 . Presence + Lighting**

Changes to reverse video mode when the parking lights are on.

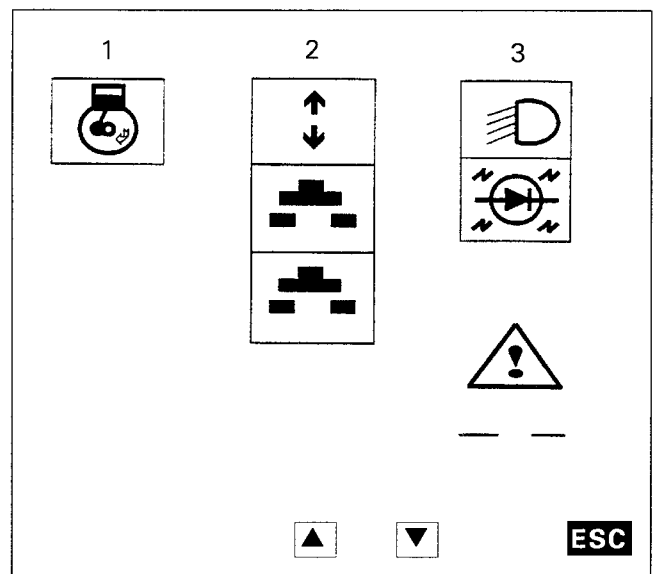





## Electronics - Electronic lift control

### Frequency inputs

From the external controls monitoring screen, press  to display the «Frequency inputs» screen.

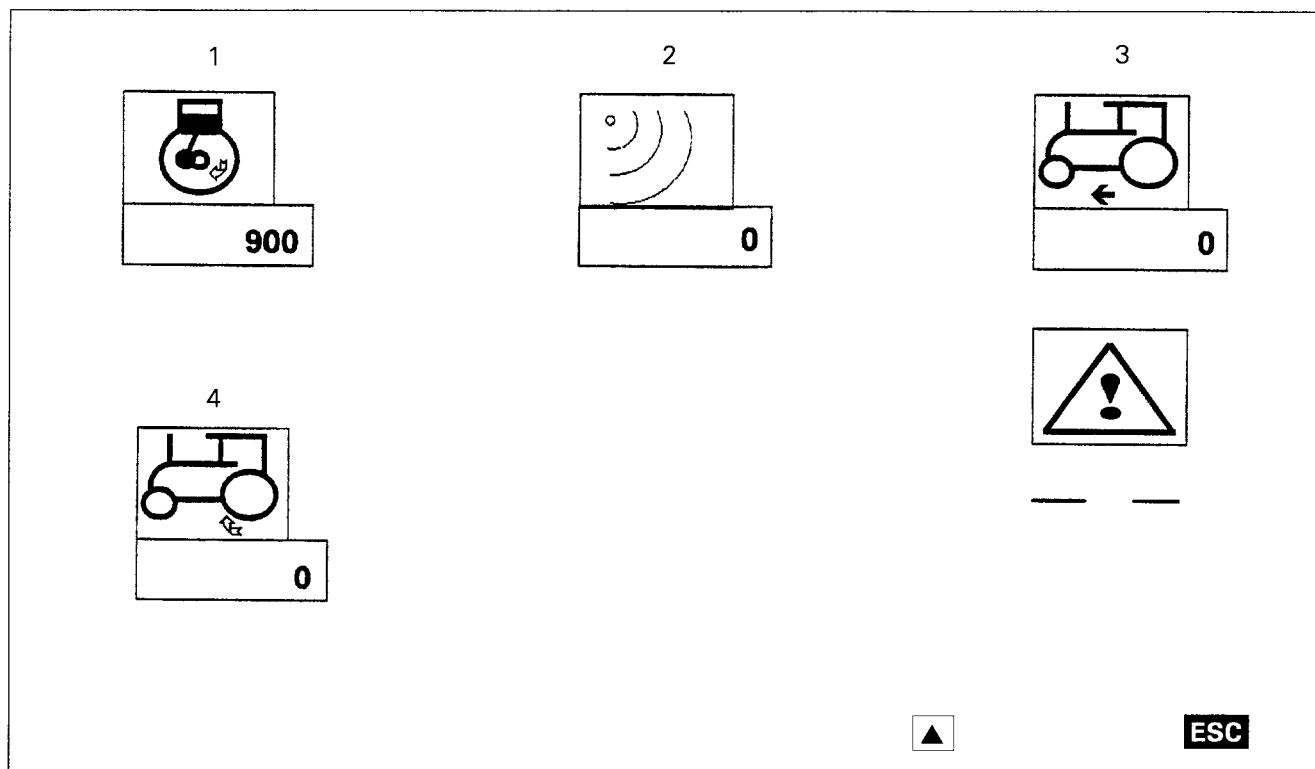

1 . Engine speed (rpm)

2 . Actual forward speed (radar) (in km/h)

3 . Theoretical forward speed (sensor) (in km/h)

#### 4 . Wheel slip control information

When Datatronic is installed, the tester displays the MAX WHEEL SLIP set point if the Datatronic is in active wheel slip control mode (otherwise the set point remains at zero).

If the frequency transmitted is abnormally low (connection problem or problem on Datatronic), the tester then displays a failure symbol next to the wheel slip icon.

A . To return to one of the previous screens, press



B . To quit «Monitoring» and return to the function selection screen, press **ESC**



11B04.8

## 6100 SERIES TRACTORS

**Electronics - Electronic lift control****F . Position sensor adjustment**

The tester offers the following choice: Monitoring, Sensor adjustment.

Select «Sensor adjustment».

Press OK.

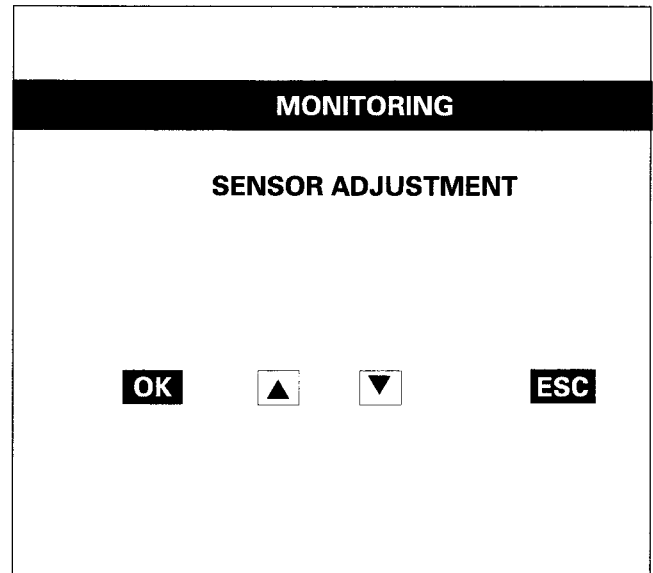

This function was selected when the impact damper was engaged.

The icon is displayed to remind you that the position sensor cannot be adjusted when this function is engaged. Press the damper button.

The icon should disappear.

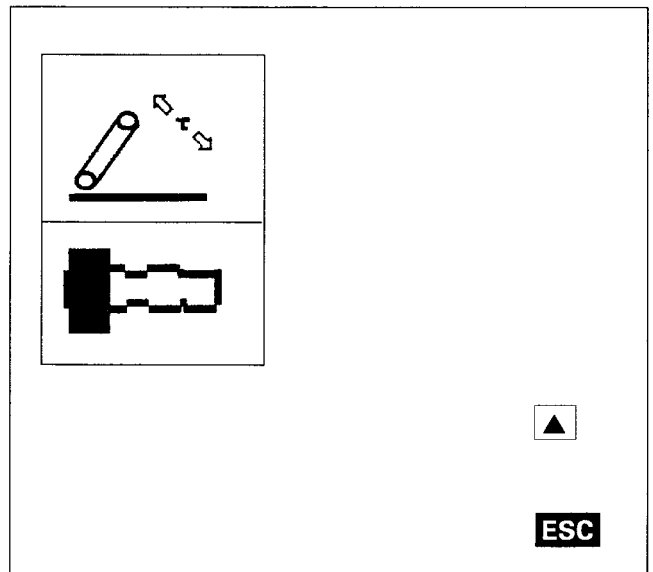
**Adjustment procedure**

- Place the lift control in the high stop position with the external controls.
- Position the sensor in contact with the cam.
- Lower the lift linkage by 3 to 5 cm.
- Adjust the sensor in order to obtain a value of 235 + 1 on the screen.

If the value is incorrect, the tester indicates the direction it should be adjusted:

 Tighten

 Loosen

**OK** ADJUSTMENT IS CORRECT

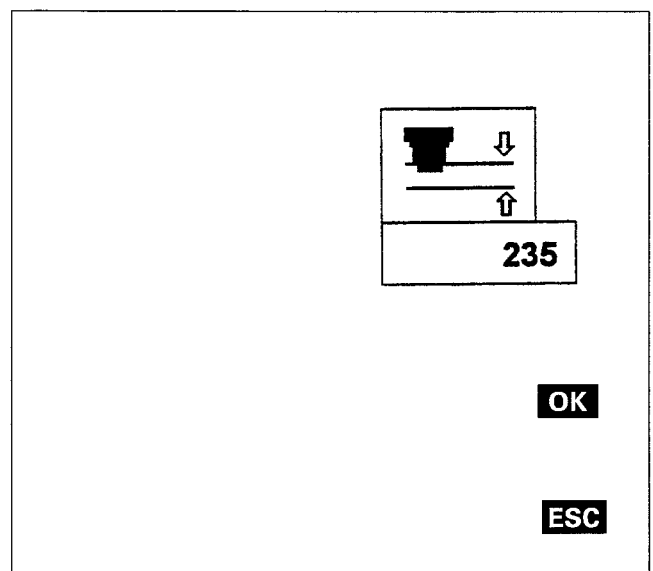



*11 C01 Description*

CONTENTS

A.	<b>Description</b> _____	2
B.	<b>Diagram (Hydro-electrical reverse shuttle - control by switch)</b> _____	7
C.	<b>Diagram (Hydro-electrical reverse shuttle - control by lever)</b> _____	10



11C01.2

## 6100 SERIES TRACTORS

**Autotronic 2 - Description****A . Description****General**

The following information and procedure apply to the **Autotronic 2** system featuring the new ETCU box 3618318M5 fitted on 6100 tractors.

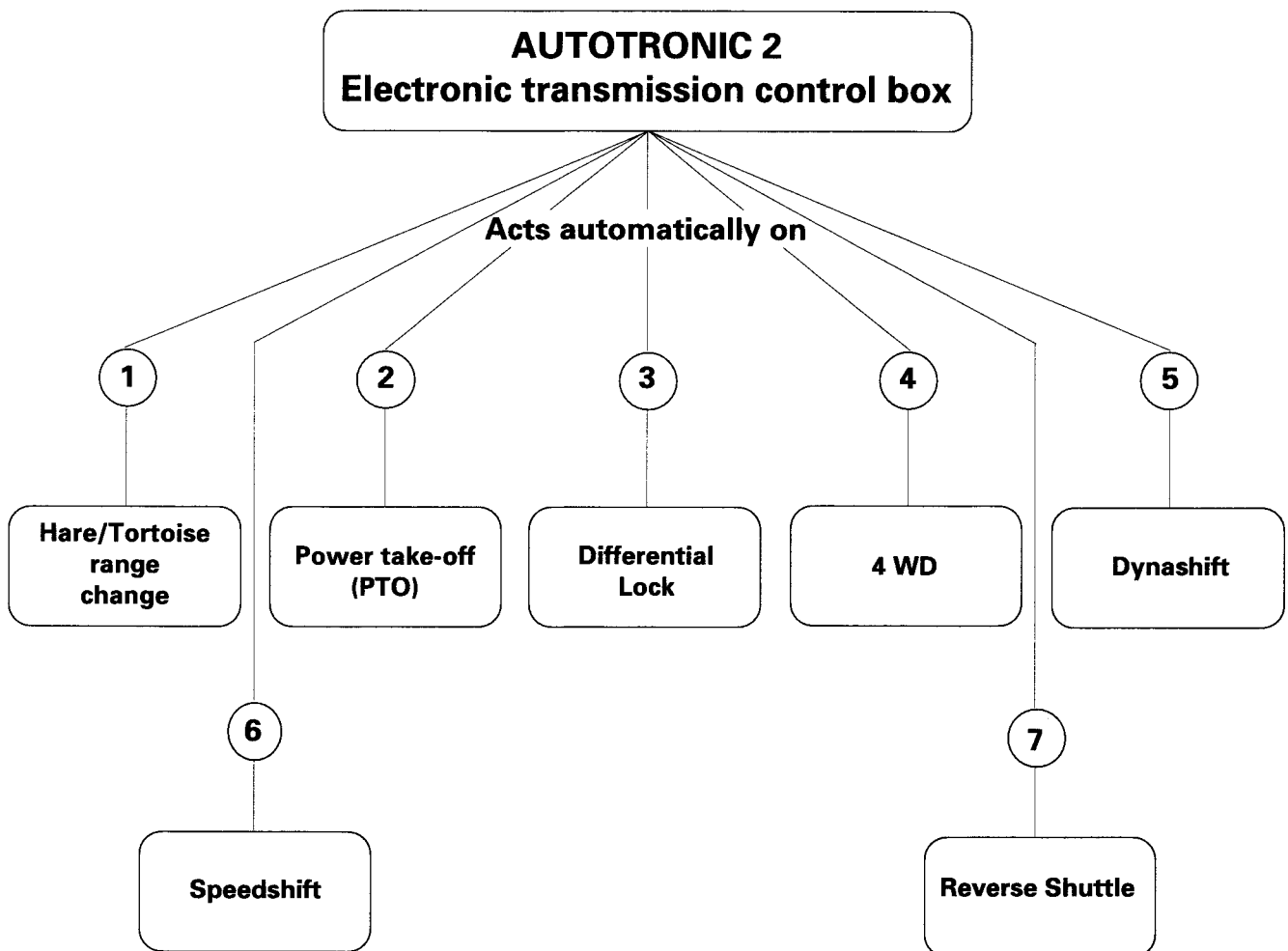
**Hydraulic protection of functions 1 - 2 - 3 - 4 - 5 - 6 - 7**

If hydraulic pressure becomes too low (17 bar nominal). The red pressure warning light comes ON and the Autotronic system comes to an Alarm Mode.

In this mode :

1. The Hare/Tortoise shifting is prevented.
2. The PTO is disengaged automatically.
3. The Diff.lock is disengaged automatically.
4. The 4WD is engaged automatically.
5. The Dynashift shifts automatically to D range.
6. The Speedshift is blocked in the last position (any change is prevented).
7. The forward reverse is blocked in the last position (any change is prevented).



## Autotronic 2 - Description

### HARE/TORTOISE RANGE CHANGE

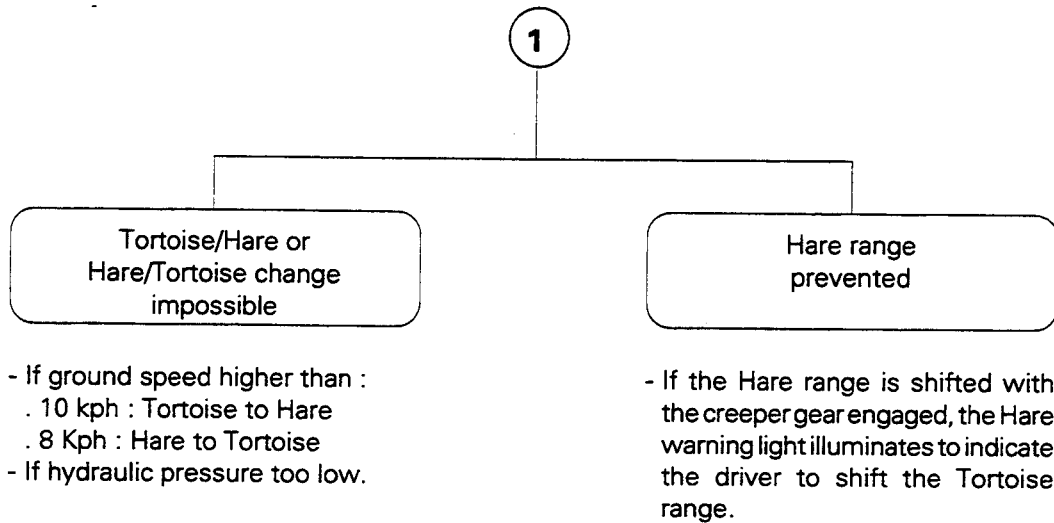

### POWER TAKE-OFF

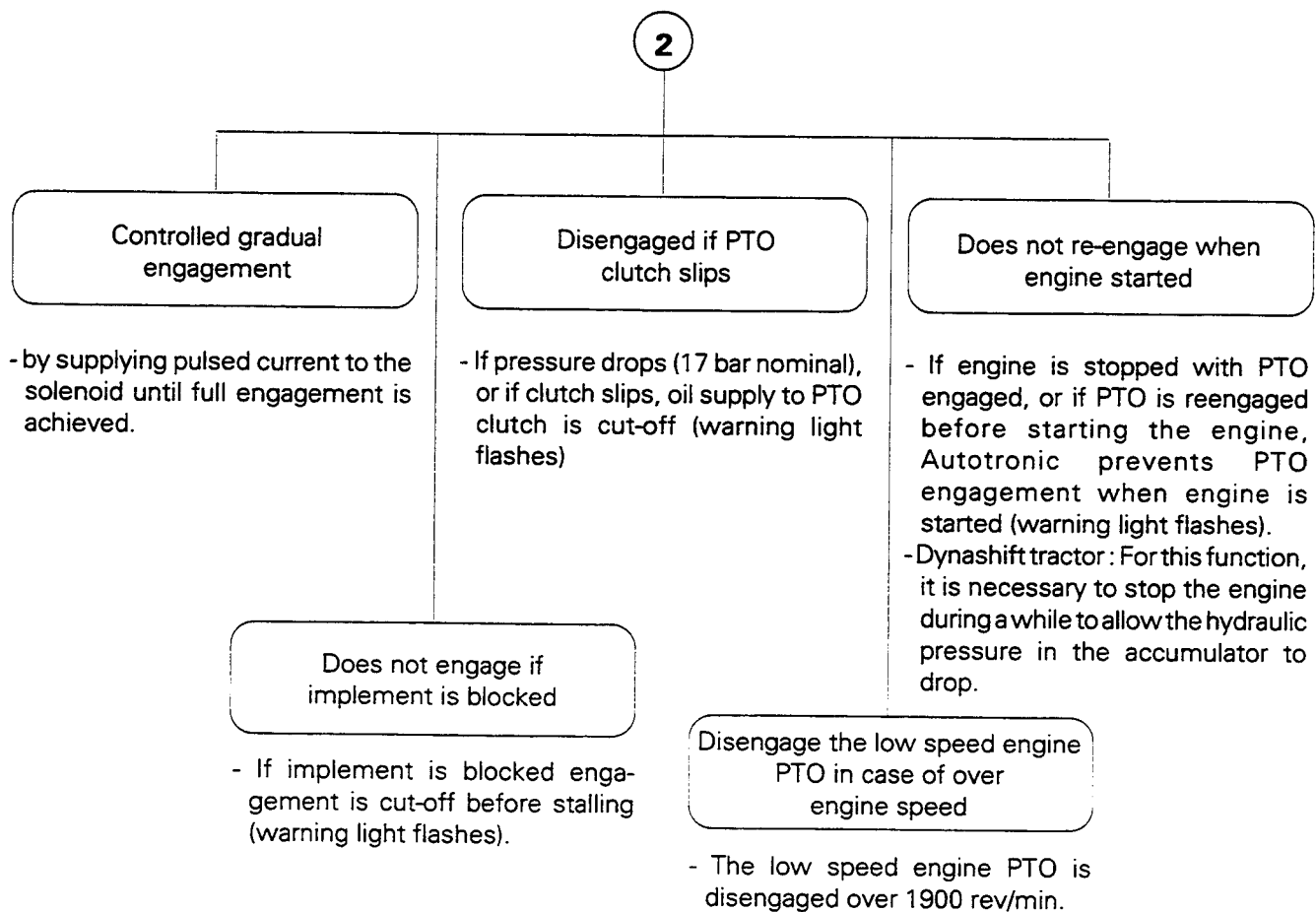



11C01.4

## 6100 SERIES TRACTORS

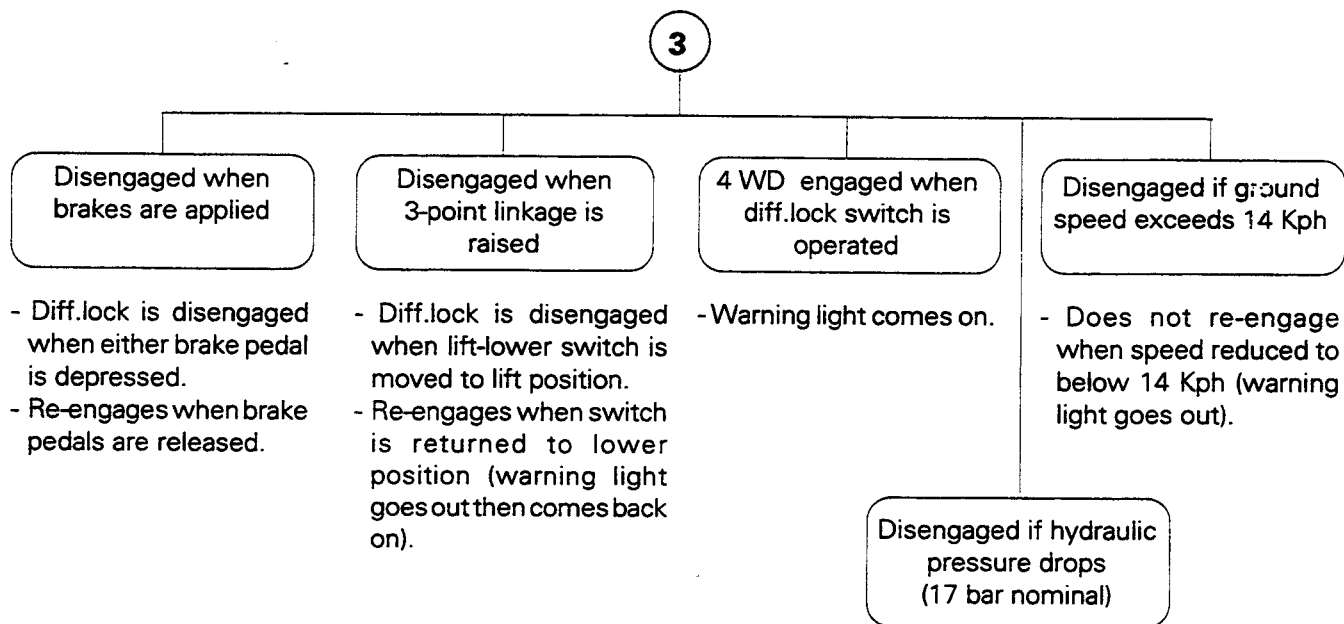
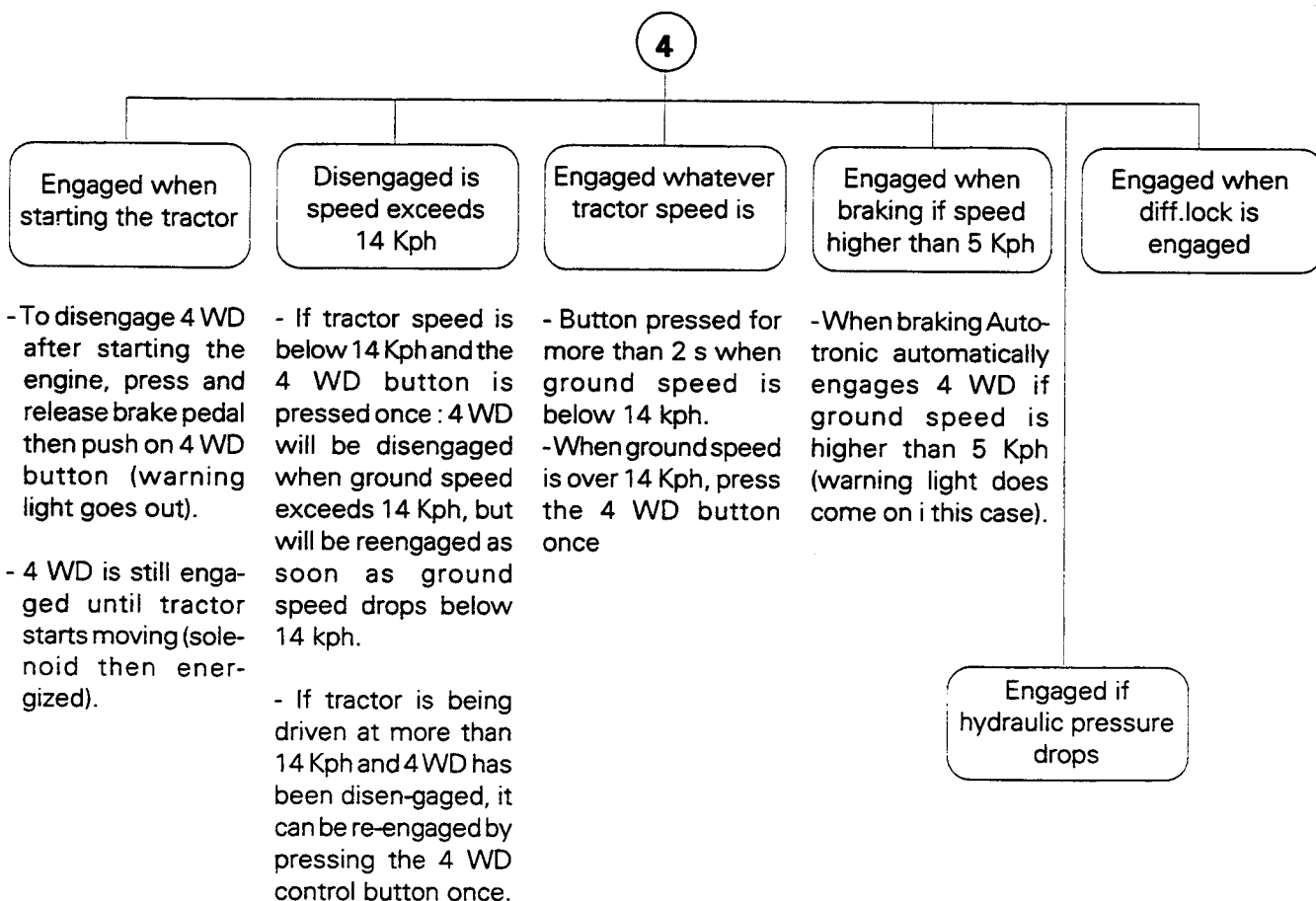
**Autotronic 2 - Description****DIFFERENTIAL LOCK****FOUR WHEEL DRIVE**

**Autotronic 2 - Description**

11C01.5

## DYNASHIFT

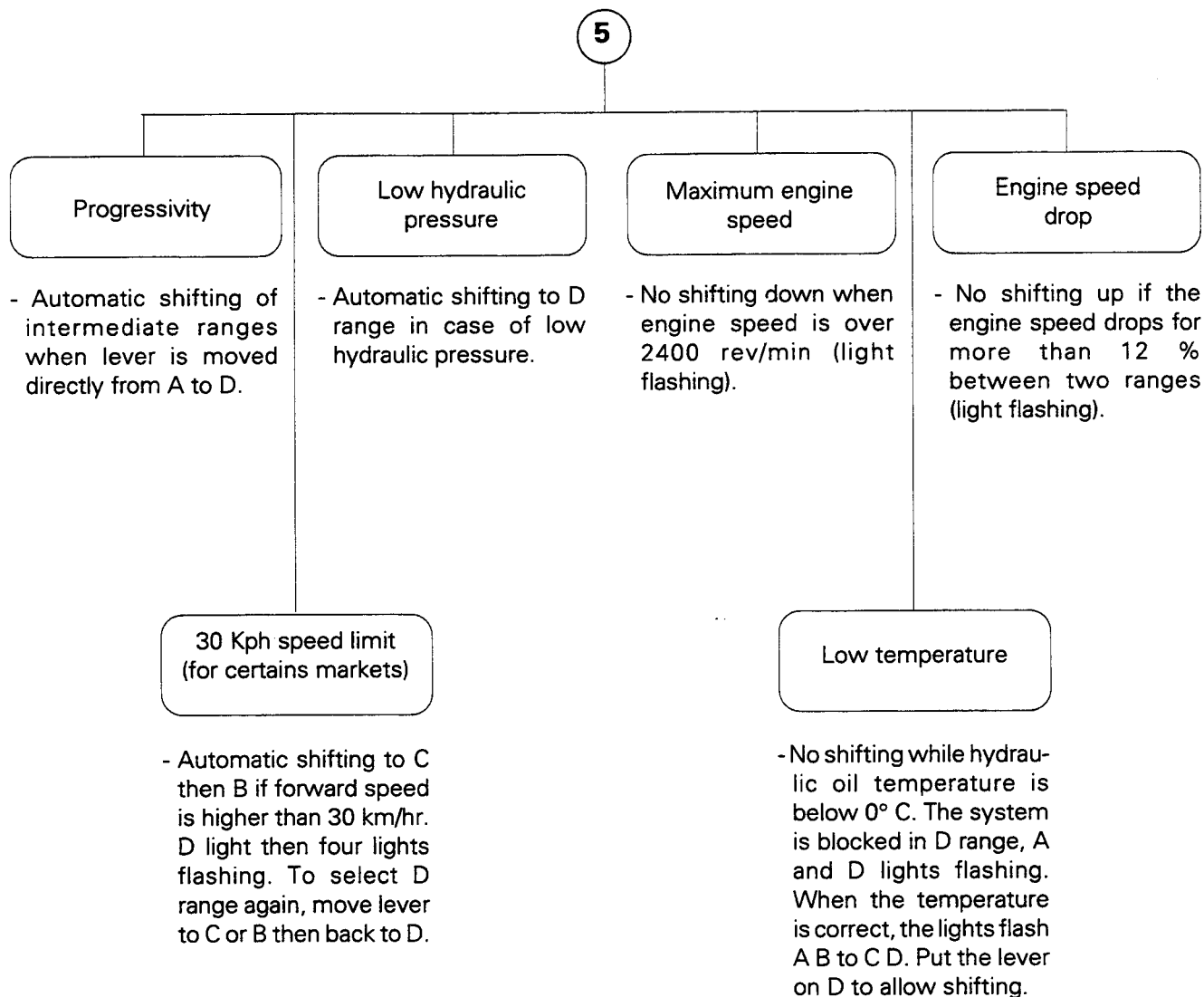



11C01.6

## 6100 SERIES TRACTORS

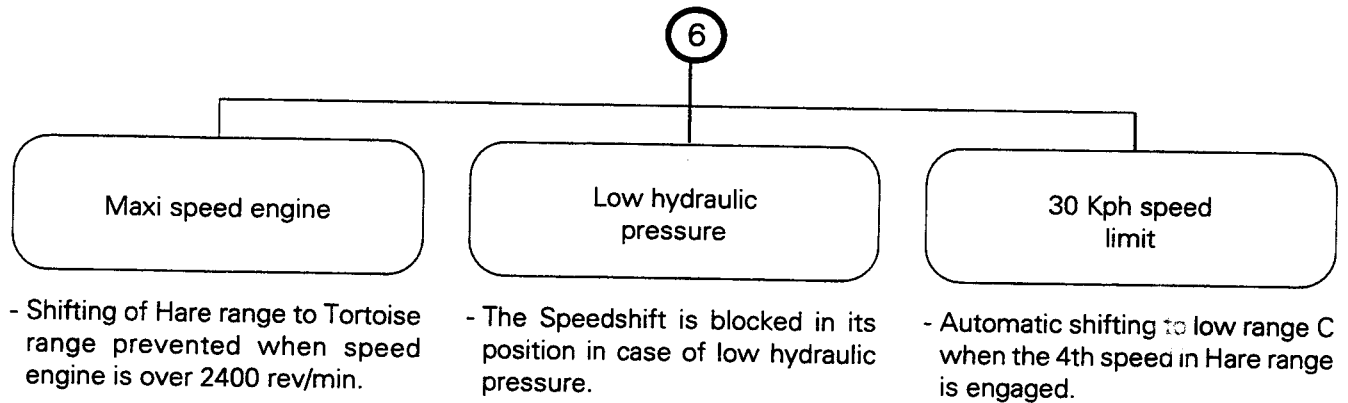
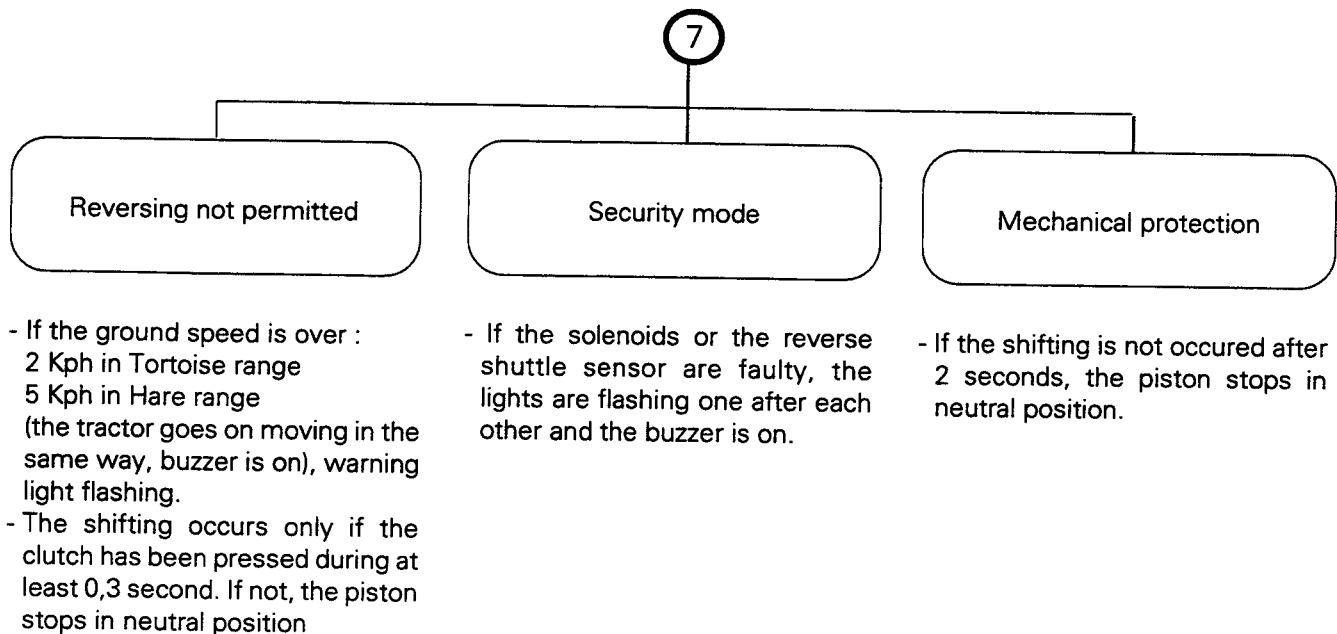
**Autotronic 2 - Description****SPEEDSHIFT****REVERSE SHUTTLE**





---

6100 SERIES TRACTORS

---



***Autotronic 2 - Description***

11C01.7



# Autotronic 2 - Description



11C01.7

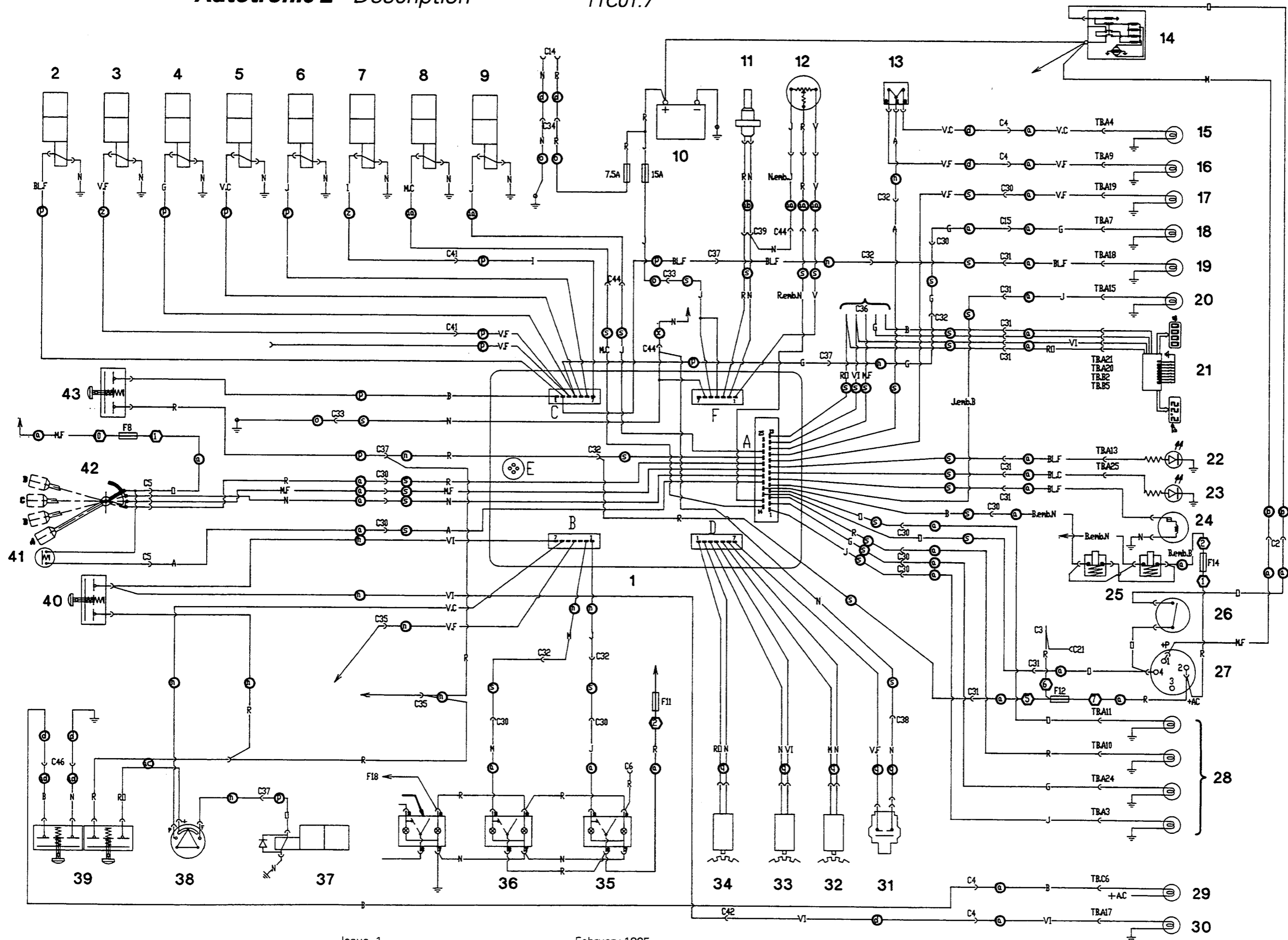



11C01.8

---

**6100 SERIES TRACTORS**

---

**Autotronic 2 - Description**
**Speedshift**

- 1 - Electronic Transmission Control unit
- 2 - Differential lock solenoid
- 4 - Hare/Tortoise solenoid
- 5 - Rear PTO solenoid
- 6 - 4WD solenoid
- 8 - Reverse gear solenoid
- 9 - Forward speed solenoid
- 10 - Battery
- 12 - Reverse shuttle piston sensor
- 13 - PTO switch 500/1000 Rev/min
- 14 - Starter motor
- 15 - PTO warning light 540 Rev/min
- 16 - PTO warning light 1000 Rev/min
- 17 - Hydraulic pressure warning light
- 18 - Hare warning light
- 19 - Differential lock warning light
- 20 - 4WD warning light
- 21 - Digital display PTO and forward speed
- 22 - Reverse gear warning light
- 23 - Forward speed warning light
- 24 - Buzzer - Way of motion
- 25 - Brake switch
- 26 - Safety switch - clutch
- 27 - Ignition and starter switch
- 29 - GSPTO warning light
- 30 - Economy PTO warning light
- 31 - Hydraulic pressure switch (17 bar)
- 32 - Engine speed sensor
- 33 - Forward speed sensor
- 34 - Rear PTO sensor
- 35 - 4WD switch
- 36 - Differential lock switch
- 37 - Solenoid - Rear PTO brake
- 38 - Rear PTO switch
- 39 - GSPTO switches
- 40 - Economy PTO switches
- 41 - Reverse shuttle switches
- 43 - Hare/Tortoise switch
- 44 - Speedshift warning light
- 45 - Speedshift control lever
- 46 - Speedshift warning light - Fast
- 47 - Speedshift warning light - Slow



# Autotronic 2 - Description



11C01.8

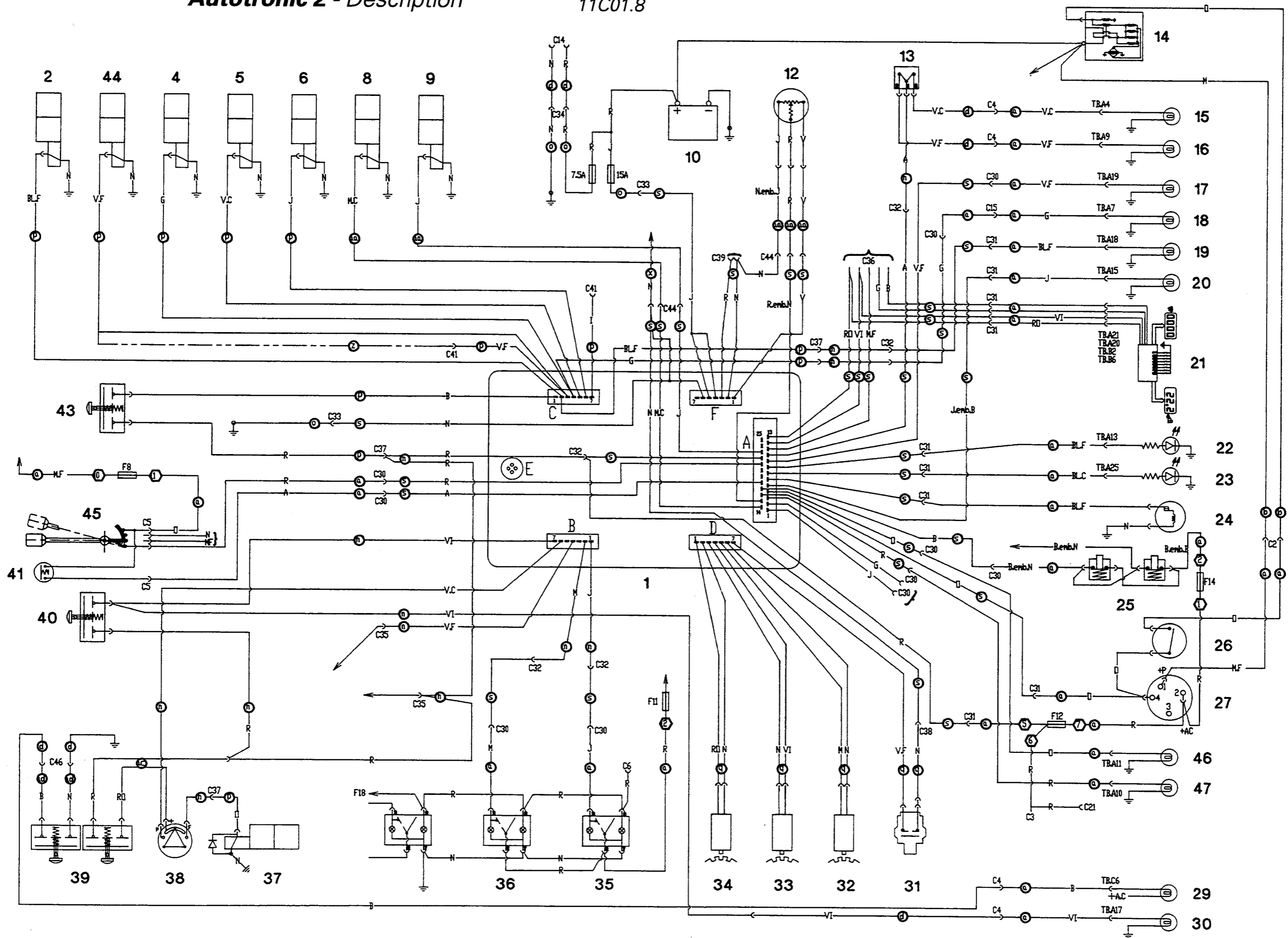



11C01.9

## Autotronic 2 - Description

### Super creeper gear

- 1 - Electronic Transmission Control unit
- 2 - Differential lock solenoid
- 4 - Hare/Tortoise solenoid
- 5 - Rear PTO soneloid
- 6 - 4WD soneloid
- 8 - Reverse gear soneloid
- 9 - Forward speed solenoid
- 10 - Battery
- 12 - Reverse shuttle piston sensor
- 13 - PTO switch 500/1000 Rev/min
- 14 - Starter motor
- 15 - PTO warning light 540 Rev/min
- 16 - PTO warning light 1000 Rev/min
- 17 - Hydraulic pressure warning light
- 18 - Hare warning light
- 19 - Differential lock warning light
- 20 - 4WD warning light
- 21 - Digital display PTO and forward speed
- 22 - Reverse gear warning light
- 23 - Forward speed warning light
- 24 - Buzzer - Way of motion
- 25 - Brake switch
- 26 - Safety switch - clutch
- 27 - Ignition and starter switch
- 29 - GSPTO warning light
- 30 - Economy PTO warning light
- 31 - Hydraulic pressure switch (17 bar)
- 32 - Engine speed sensor
- 33 - Forward speed sensor
- 34 - Rear PTO sensor
- 35 - 4WD switch
- 36 - Differential lock switch
- 37 - Solenoid - Rear PTO brake
- 38 - Rear PTO switch
- 39 - GSPTO switches
- 40 - Economy PTO switches
- 41 - Reverse shuttle switches
- 43 - Hare/Tortoise switch
- 45 - Speedshift control lever (non fonctional)
- 46 - Speedshift warning light - Fast
- 47 - Speedshift warning light - Slow
- 48 - Super creeper solenoid
- 49 - Super creeper switch



# Autotronic 2 - Description



11C01.9

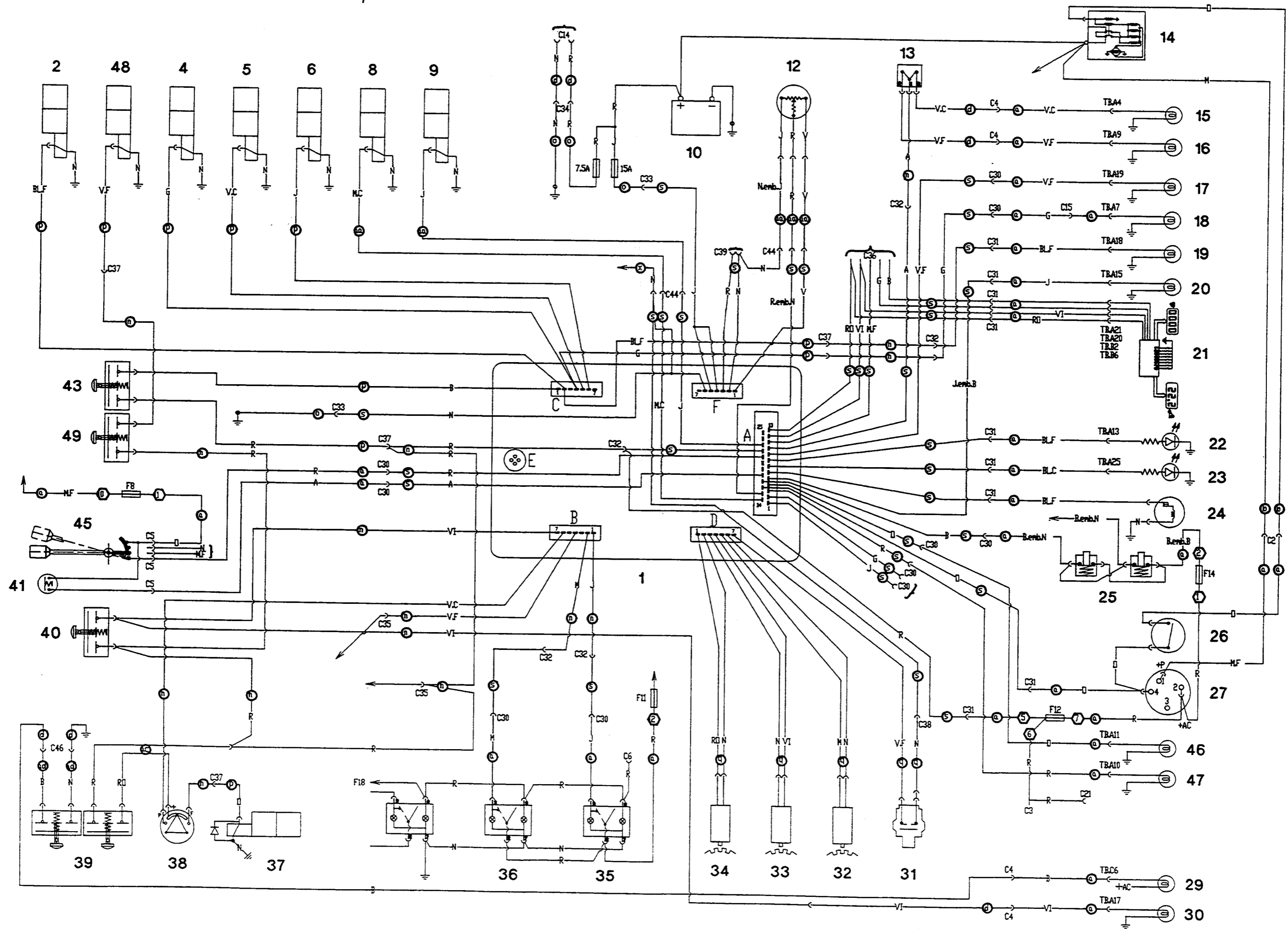



11C01.10

---

 6100 SERIES TRACTORS
 

---

**Autotronic 2 - Description**

---

**C. Diagram (Hydro-electrical reverse shuttle - Control by lever)**

---

**Dynashift**

- 1 - Electronic Transmission Control unit
- 2 - Differential lock solenoid
- 3 - Dynashift solenoid EV2 (3x2)
- 4 - Hare/Tortoise solenoid
- 5 - Rear PTO soneloid
- 6 - 4WD soneloid
- 7 - Dynashift soneloid EV1 (4x2)
- 8 - Reverse gear soneloid
- 9 - Forward speed solenoid
- 10 - Battery
- 11 - Temperature sensor
- 12 - Reverse shuttle piston sensor
- 13 - PTO switch 500/1000 Rev/min
- 14 - Starter motor
- 15 - PTO warning light 540 Rev/min
- 16 - PTO warning light 1000 Rev/min
- 17 - Hydraulic pressure warning light
- 18 - Hare warning light
- 19 - Differential lock warning light
- 20 - 4WD warning light
- 21 - Digital display PTO and forward speed
- 22 - Reverse gear warning light
- 23 - Forward speed warning light
- 24 - Buzzer - Way of motion
- 25 - Brake switch
- 26 - Safety switch - clutch
- 27 - Ignition and starter switch
- 28 - Dynashift warning lights
- 29 - GSPTO warning light
- 30 - Economy PTO warning light
- 31 - Hydraulic pressure switch (17 bar)
- 32 - Engine speed sensor
- 33 - Forward speed sensor
- 34 - Rear PTO sensor
- 35 - 4WD switch
- 36 - Differential lock switch
- 37 - Solenoid - Rear PTO brake
- 38 - Rear PTO switch
- 39 - GSPTO switch
- 40 - Economy PTO switch
- 41 - Reverse shuttle lever
- 42 - Dynashift control lever
- 43 - Hare/Tortoise switch

**Abbreviations :**

Example : TBA4 = pin 4 on connector **A** of dashboard



11C01.10

6100 SERIES TRACTORS



Autotronic 2 - Description

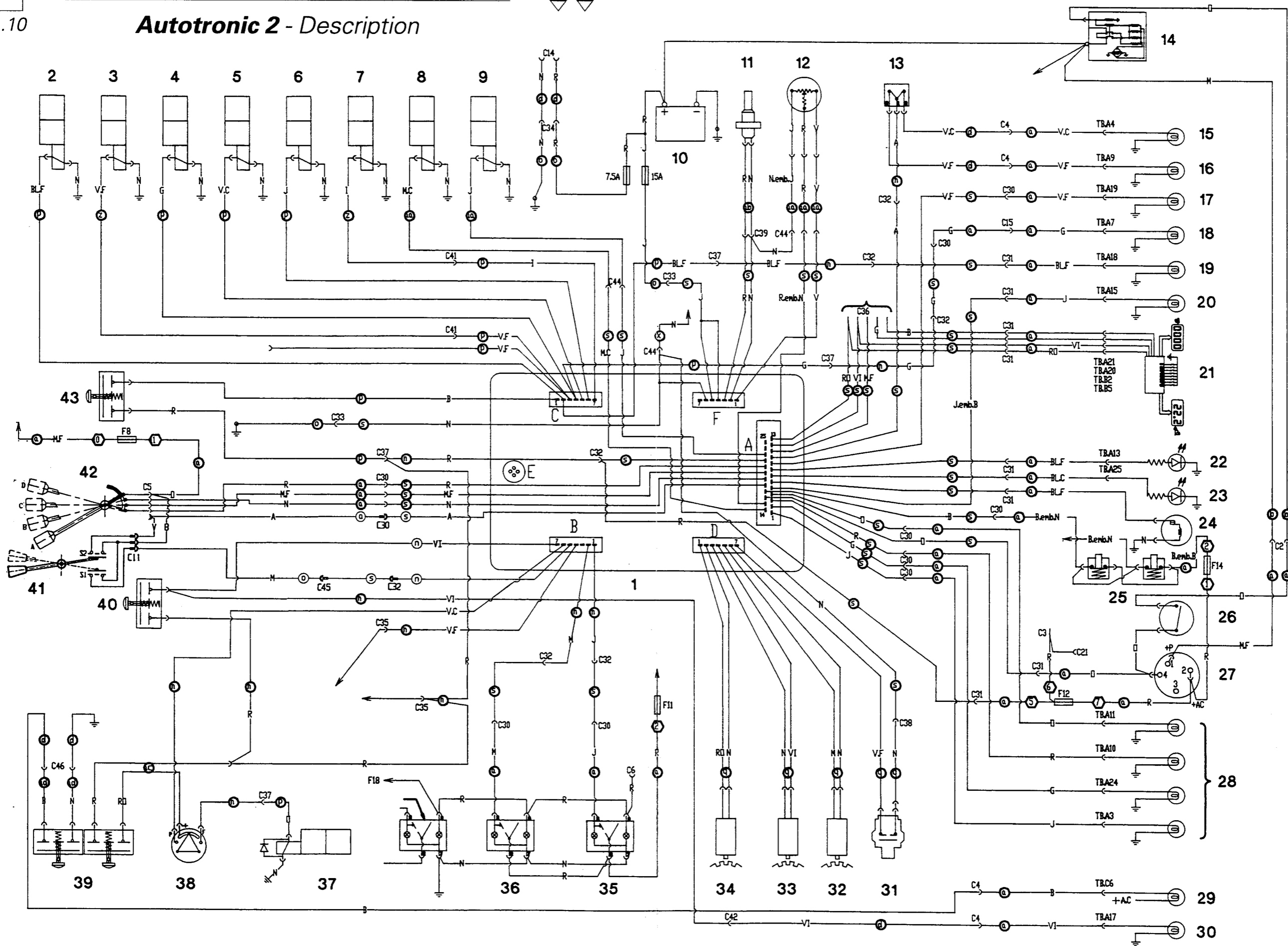





## ***Autotronic 2 - Description***

### **Speedshift**

- 1 - Electronic Transmission Control unit
- 2 - Differential lock solenoid
- 4 - Hare/Tortoise solenoid
- 5 - Rear PTO solenoid
- 6 - 4WD solenoid
- 8 - Reverse gear solenoid
- 9 - Forward speed solenoid
- 10 - Battery
- 12 - Reverse shuttle piston sensor
- 13 - PTO switch 500/1000 Rev/min
- 14 - Starter motor
- 15 - PTO warning light 540 Rev/min
- 16 - PTO warning light 1000 Rev/min
- 17 - Hydraulic pressure warning light
- 18 - Hare warning light
- 19 - Differential lock warning light
- 20 - 4WD warning light
- 21 - Digital display PTO and forward speed
- 22 - Reverse gear warning light
- 23 - Forward speed warning light
- 24 - Buzzer - Way of motion
- 25 - Brake switch
- 26 - Safety switch - clutch
- 27 - Ignition and starter switch
- 29 - GSPTO warning light
- 30 - Economy PTO warning light
- 31 - Hydraulic pressure switch (17 bar)
- 32 - Engine speed sensor
- 33 - Forward speed sensor
- 34 - Rear PTO sensor
- 35 - 4WD switch
- 36 - Differential lock switch
- 37 - Solenoid - Rear PTO brake
- 38 - Rear PTO switch
- 39 - GSPTO switch
- 40 - Economy PTO switch
- 41 - Reverse shuttle lever
- 43 - Hare/Tortoise switch
- 44 - Speedshift warning light
- 45 - Speedshift control lever
- 46 - Speedshift warning light - Fast
- 47 - Speedshift warning light - Slow



6100 SERIES TRACTORS

# Autotronic 2 - Description



11C01.11

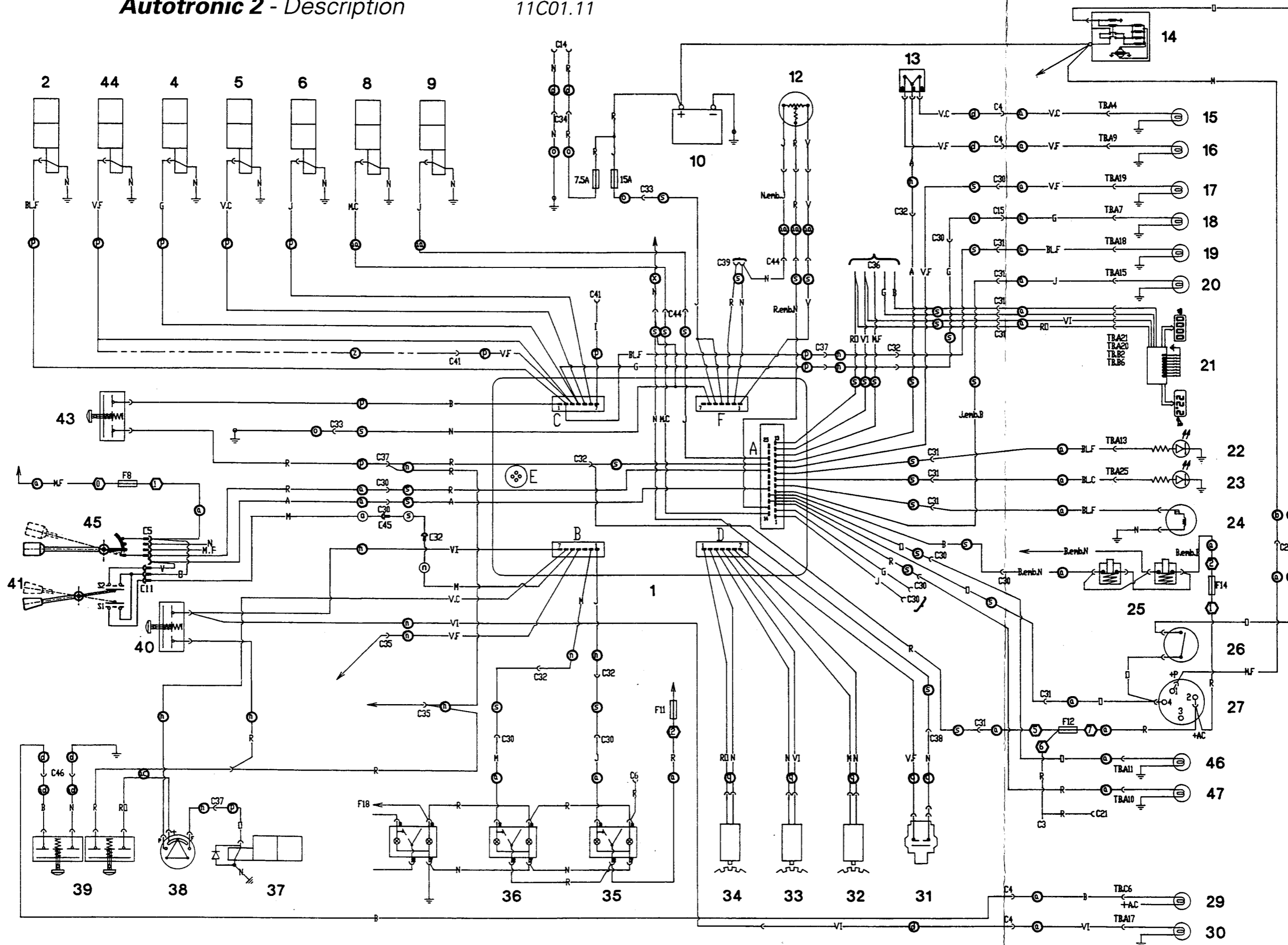



## **Autotronic 2 - Description**

### **B. Diagram (Hydro-electrical reverse shuttle - Control by switch)**

#### **Dynashift**

- 1 - Electronic Transmission Control unit
- 2 - Differential lock solenoid
- 3 - Dynashift solenoid EV2 (3x2)
- 4 - Hare/Tortoise solenoid
- 5 - Rear PTO soneloid
- 6 - 4WD soneloid
- 7 - Dynashift soneloid EV1 (4x2)
- 8 - Reverse gear soneloid
- 9 - Forward speed solenoid
- 10 - Battery
- 11 - Temperature sensor
- 12 - Reverse shuttle piston sensor
- 13 - PTO switch 500/1000 Rev/min
- 14 - Starter motor
- 15 - PTO warning light 540 Rev/min
- 16 - PTO warning light 1000 Rev/min
- 17 - Hydraulic pressure warning light
- 18 - Hare warning light
- 19 - Differential lock warning light
- 20 - 4WD warning light
- 21 - Digital display PTO and forward speed
- 22 - Reverse gear warning light
- 23 - Forward speed warning light
- 24 - Buzzer - Way of motion
- 25 - Brake switch
- 26 - Safety switch - clutch
- 27 - Ignition and starter switch
- 28 - Dynashift warning lights
- 29 - GSPTO warning light
- 30 - Economy PTO warning light
- 31 - Hydraulic pressure switch (17 bar)
- 32 - Engine speed sensor
- 33 - Forward speed sensor
- 34 - Rear PTO sensor
- 35 - 4WD switch
- 36 - Differential lock switch
- 37 - Solenoid - Rear PTO brake
- 38 - Rear PTO switch
- 39 - GSPTO switches
- 40 - Economy PTO switch
- 41 - Reverse shuttle switch
- 42 - Dynashift control lever
- 43 - Hare/Tortoise switch

#### **Abbreviations :**

Example : TB.A4 = pin 4 on connector A of dashboard



---

6100 SERIES TRACTORS

---

***Autotronic 2 - Description***



11C01.9



## **Autotronic 2 - Description**

### **Super creeper gear**

- 1 - Electronic Transmission Control unit
- 2 - Differential lock solenoid
- 4 - Hare/Tortoise solenoid
- 5 - Rear PTO solenoid
- 6 - 4WD solenoid
- 8 - Reverse gear solenoid
- 9 - Forward speed solenoid
- 10 - Battery
- 12 - Reverse shuttle piston sensor
- 13 - PTO switch 500/1000 Rev/min
- 14 - Starter motor
- 15 - PTO warning light 540 Rev/min
- 16 - PTO warning light 1000 Rev/min
- 17 - Hydraulic pressure warning light
- 18 - Hare warning light
- 19 - Differential lock warning light
- 20 - 4WD warning light
- 21 - Digital display PTO and forward speed
- 22 - Reverse gear warning light
- 23 - Forward speed warning light
- 24 - Buzzer - Way of motion
- 25 - Brake switch
- 26 - Safety switch - clutch
- 27 - Ignition and starter switch
- 29 - GSPTO warning light
- 30 - Economy PTO warning light
- 31 - Hydraulic pressure switch (17 bar)
- 32 - Engine speed sensor
- 33 - Forward speed sensor
- 34 - Rear PTO sensor
- 35 - 4WD switch
- 36 - Differential lock switch
- 37 - Solenoid - Rear PTO brake
- 38 - Rear PTO switch
- 39 - GSPTO switches
- 40 - Economy PTO switches
- 41 - Reverse shuttle switches
- 43 - Hare/Tortoise switch
- 45 - Speedshift control lever (non functional)
- 46 - Speedshift warning light - Fast
- 47 - Speedshift warning light - Slow
- 48 - Super creeper solenoid
- 49 - Super creeper switch



11C01.12

---

 6100 SERIES TRACTORS
 

---

**Autotronic 2 - Description**
**Super creeper gear**

- 1 - Electronic Transmission Control unit
- 2 - Differential lock solenoid
- 4 - Hare/Tortoise solenoid
- 5 - Rear PTO soneloid
- 6 - 4WD soneloid
- 8 - Reverse gear soneloid
- 9 - Forward speed solenoid
- 10 - Battery
- 12 - Reverse shuttle piston sensor
- 13 - PTO switch 500/1000 Rev/min
- 14 - Starter motor
- 15 - PTO warning light 540 Rev/min
- 16 - PTO warning light 1000 Rev/min
- 17 - Hydraulic pressure warning light
- 18 - Hare warning light
- 19 - Differential lock warning light
- 20 - 4WD warning light
- 21 - Digital display PTO and forward speed
- 22 - Reverse gear warning light
- 23 - Forward speed warning light
- 24 - Buzzer - Way of motion
- 25 - Brake switch
- 26 - Safety switch - clutch
- 27 - Ignition and starter switch
- 29 - GSPTO warning light
- 30 - Economy PTO warning light
- 31 - Hydraulic pressure switch (17 bar)
- 32 - Engine speed sensor
- 33 - Forward speed sensor
- 34 - Rear PTO sensor
- 35 - 4WD switch
- 36 - Differential lock switch
- 37 - Solenoid - Rear PTO brake
- 38 - Rear PTO switch
- 39 - GSPTO switch
- 40 - Economy PTO switch
- 41 - Reverse shuttle lever
- 43 - Hare/Tortoise switch
- 46 - Speedshift warning light - Fast
- 47 - Speedshift warning light - Slow
- 48 - Super creeper solenoid
- 49 - Super creeper switch



11C01.12

6100 SERIES TRACTORS



Autotronic 2 - Description

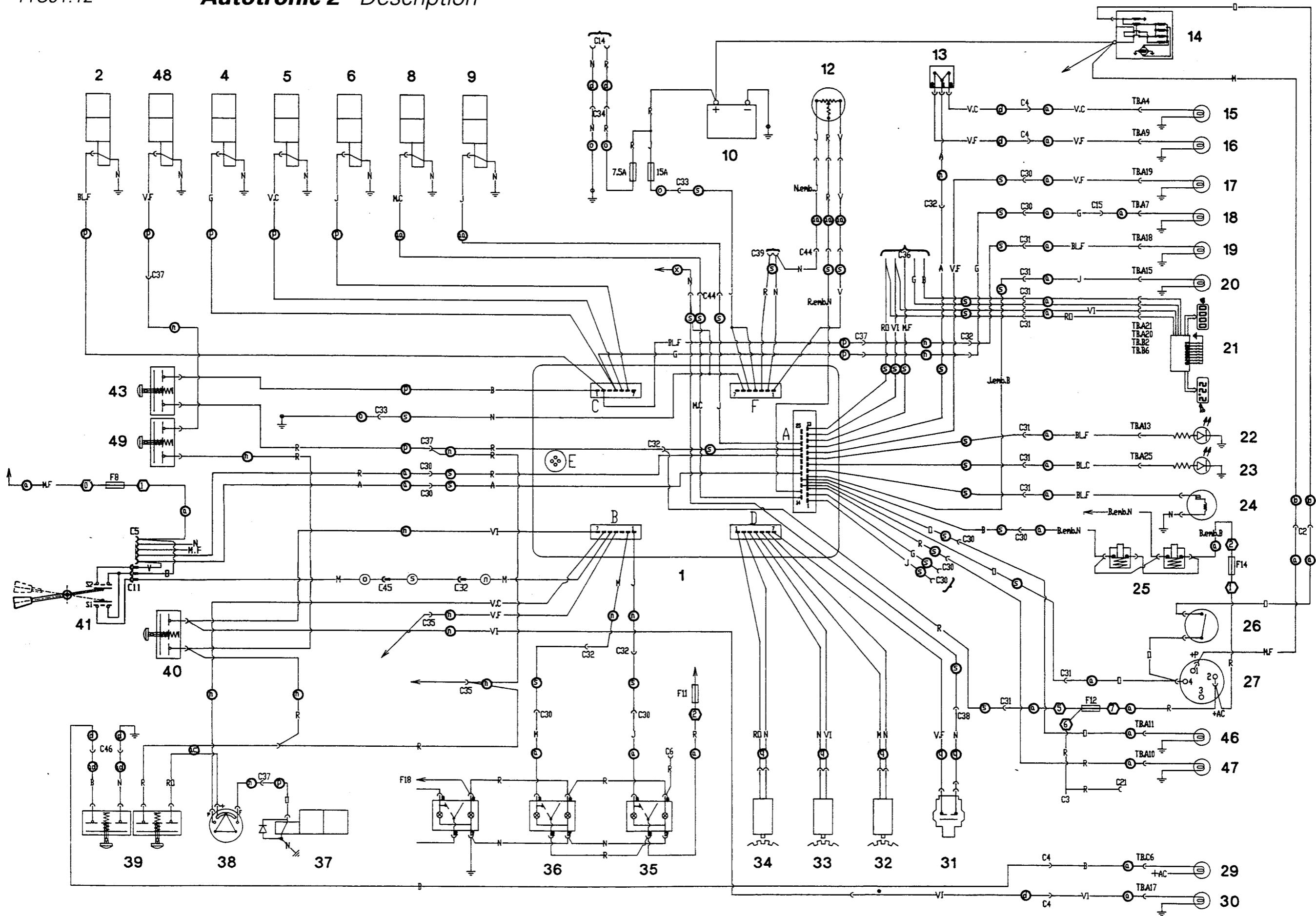



**Autotronic 2 - Checking without tester**

11C02.1

*11 C02 Checking without tester*

CONTENTS

A.	Testing procedure	_____	2
B.	Defects analysis	_____	7





11C02.2

## 6100 SERIES TRACTORS

**Autotronic 2 - Checking without tester****A . Testing procedure**

This procedure is for checking correct operation of the electronic transmission control unit Autotronic 2 as well as for solving very simple breakdown problems.

**1 . Power supply**

**Engine stopped, ignition off, all warning lights OFF.**

**Declutch :** The following warning lights should illuminate almost immediately :

- hydraulic pressure,
- then
- A, B, C, D lights,
- at the end
- hydraulic pressure,
- 4 WD,
- Hare/Tortoise,
- D range
- forward and backward lights

**Re-engage :** The warning lights should extinguish after a few seconds.

This shows that :

- there is power supply to the Autotronic system,
- processor is operating,
- hydraulic pressure warning light, 4 WD light, Hare/Tortoise, A, B, C, D range, forward and backward lights are correctly wired,
- clutch switch is correct.

**Note : To confirm power supply is correct, check battery voltage and lines resistance.**

**2 . Hydraulic pressure switch / Engine speed sensor****a) Engine stopped, ignition off**

Declutch

The warning lights illuminate as per test 1.

Start the engine, idling.

The red pressure warning light should extinguish after a few seconds and the backward or forward lights or both lights are flashing, the buzzer is on.

This shows that :

- the engine speed sensor is wired and operates correctly.
- the hydraulic pressure switch circuit closes.
- the motion lights and the buzzer are OK.

**b) If 2a correct :**

Stop the engine.

After a few seconds the red pressure warning light, the D range light, the 4 WD one, the Hare one if the Hare range is engaged should re-illuminate before all warning lights extinguish.

**Note : It may be necessary to wait 4 or 5 minutes for the warning light to re-illuminate if a hydraulic accumulator is fitted (Dynashift or super-creeper fitment).**

This shows that :

- the hydraulic pressure switch is wired and operates correctly (re-opening).

**3 . Differential lock****Engine idling**

4 WD light illuminated.

- Press differential lock button.
- Differential lock light illuminates.
- Press differential lock button again.
- Differential lock warning light extinguishes.
- Whilst moving along at 4 Kph, engage the differential lock. The 4 WD will engage as well.
- Make a tight turn. You should see the rear tires skid when the differential lock is engaged and feel a jerk as you engage and disengage.
- The differential lock disengage itself above 14 kph.
- The differential lock disengage itself in braking.
- Raise and lower the lift. The differential lock warning light should illuminate and extinguish.

This shows that :

- supply to switches seems correct,
- differential lock button is correct,
- differential lock warning light is correct.
- the solenoid is wired and operating.
- the differential lock is operating.

**4 . Brake switch****Engine idling**

4 WD light illuminated.

Press differential lock button again.

Differential lock light illuminates.

Unlatch brake pedals. Apply light pressure to each brake pedal in turn. The differential lock warning light should go out as soon as each pedal has left the return stop.

This shows that :

- the two brake switches are correct and well adjusted.
- the supply to the brake switches is correct.



## Autotronic 2 - Checking without tester

### 12. Reverse shuttle

- Drive the tractor at 4 Kph, forward gear engaged. The forward warning light is on. Press the button on the Dynashift lever to select the reverse gear, the reverse warning light is flashing and the buzzer is on. Press the clutch more than 0,2 second, the reverse warning light is on and the forward one is off. The tractor is moving backwards.
- Then select the forward gear. The forward warning light is flashing and the buzzer is on. Press the clutch more than 0,3 second, the forward warning light stays on and the reverse one is off.
- Check also that over 2 Kph in Tortoise and over 5 Kph in Hare, it is not permitted to use the reverse shuttle (buzzer stays on, and the tractor keep going in the same way, the selected reverse shuttle light is flashing).

### Description of safety mode

If the two forward/reverse warning lights are flashing, one after each other, and the buzzer is on, the Autotronic is in safety mode. A failure has been detected on the forward/reverse shuttle sensor or on the solenoids.

Then, you have to stop the engine and wait for the Autotronic to be in sleep mode (all the dashboard lights have to be off) and then to **recalibrate** the forward/reverse shuttle sensor.

Four different recalibration modes are existing depending on the Autotronic version (indicated on the label : OP-SOFTWARE n° 02795-00 Issue F, G, H, I, K, L or M)

#### - F and G version (from D026027 to D090021)

- . Press the clutch pedal and the brake pedals.
- . Start the engine in keeping the pedals pressed.
- . The forward and reverse warning lights are flashing and the buzzer is on during about 10 seconds. The recalibration is finished when the lights and buzzer are off.

#### - H version (from D090022 to D118021)

- . Press the clutch pedal and the differential lock button.
- . Start the engine in keeping the differential lock button and the clutch pedal pressed.
- . The forward and reverse warning lights are flashing and the buzzer is on during about 10 seconds. The recalibration is finished when the lights and buzzer are off.

#### - I version (from D118022 to D208008)

- . Press the clutch pedal and the differential lock button.
- . Start the engine in keeping the differential lock and the clutch pedal pressed, the buzzer is on and the forward and reverse lights are flashing.

- . When the low pressure is off, depress the clutch pedal and push the gear lever to contact the Hi-Lo switch and keep it in this position.
- . After 10 seconds, release the differential lock button and the gear lever and press the clutch pedal. The recalibration is finished and the lights and the buzzer are off.

If after 10 seconds, the Autotronic goes back in safety mode, it means the forward/reverse shuttle sensor or the solenoids are faulty or the recalibration is not correct, you can move the tractor in safety mode in pressing the pedal clutch and then pressing the forward/reverse shuttle button.

There are three different possibilities :

- a) After the first pulse, the forward light is flashing, the buzzer is on and the tractor is moving forwards. After the second pulse, the backward light is flashing, the buzzer is on and the tractor is moving backwards. The reverse shuttle sensor is faulty.
- b) After the first pulse, the forward light is flashing, the buzzer is on and the tractor is moving backwards. After the second pulse, the backward light is flashing, the buzzer is on and the tractor is moving forward. The connection of the solenoids has been reversed.
- c) After the first and the second pulse, the tractor is moving on the same direction. One solenoid is faulty. If the tractor is only moving forwards, the solenoid at the back of the reverse shuttle selector cover is faulty. If the tractor is only moving backwards, the solenoid at the front of the reverse shuttle selector cover is faulty.

#### - Version K (from D208009 to D265030)

Initialising and safety modes are identical to those of version I but their identification on the dashboard is modified as follows :

- . As soon as one of the indicator lights remains on in steady mode, the other continues to flash and the buzzer continues to be sounded :
  - release the differential lock switch and the gear lever,
  - press the clutch pedal.

Initialisation of the reverse shuttle has been completed. The indicator light which was flashing remains on in steady mode. The other goes out and the buzzer is no longer sounded.



11C02.6

## 6100 SERIES TRACTORS

**Autotronic 2 - Checking without tester****- Versions L and M (as from D265031)**

Initialisation must, mandatorily, be performed after :

- Replacing the Autotronic unit.
- Disconnecting the position sensor from the reverse shuttle fork while the Autotronic unit is in work mode (engine speed OK, low pressure OK).
- Reprogramming in version L, M, etc.
- Reparameterisation.
- Any mechanical servicing on the gearbox.

**Advice before initialisation**

- With the engine running, operate the range lever to light up the Hare indicator light on the dashboard. Then, during initialisation, the indicator light must go out when the gear lever is moved, which confirms that the Hare / Tortoise switch is operating correctly.

**Initialisation procedure**

- With the engine stopped and the ignition switched off and the indicator lights controlled by the Autotronic unit extinguished.
- Press the clutch pedal.
- Press the differential lock switch and **hold it down throughout the initialisation phase.**
- Start the engine.
- Within 10 seconds of the low pressure light going out, release the clutch pedal.
- Shift the gear lever to actuate the Hare/Tortoise switch and **hold it in that position.**

During initialisation, the front (**green**) and rear (**red**) direction indicator lights flash simultaneously and the buzzer is sounded.

As soon as one of the indicator lights remains on in steady mode, the other continues to flash and the buzzer continues to be sounded :

- release differential lock switch and the gear lever
- press the clutch pedal

Initialisation has now been completed. Only the preselected direction indicator light remains constantly lit up and the buzzer is no longer sounded.

**Important : During the initialisation phase, do not release the differential lock switch or the gear lever.**

**Checking the travel of the reverse shuttle fork**

The travel of the fork is checked by carrying out the following procedure in the order stated:

- Connect the tester and select the screen (see 11 C03).
- Start the engine.

- Disconnect the reverse shuttle sensor to be in alarm mode.
- Reconnect the sensor.
- Press the clutch pedal, select forward motion and read the maximum value on the tester. Then release the clutch pedal and read the withdrawal of the fork, e.g. 148 then withdrawal of 130.
- Press the clutch pedal, select rearward motion and read the maximum value on the tester. Then release the clutch pedal and read the withdrawal of the fork, e.g. 17 then withdrawal of 27.

**Note : The travel is read in the bottom right-hand part of the screen. If the difference between the value and the withdrawal is greater than 10 points, this means there is a mechanical fault : fork, synchro, etc..**

For information, the mean value is a withdrawal of between 2 and 5 points.

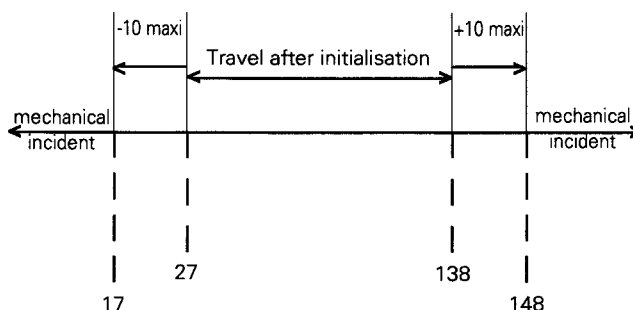

Reinitialise the reverse shuttle as before.

**13. Speedshift****Engine idling**

- Check that the two lever positions correspond to the working lights (C and D).

**Tractor moving**

- Check that the forward speed is increasing from C to D and decreasing from D to C.

This shows that :

- the warning lights are correct.
- the lever is correctly wired and its supply is correct.
- the solenoid is operating.
- the forward speed sensor and the ETCU are operating.



## Autotronic 2 - Checking without tester

11C02.7

### B . Analysis of the possible defects

The aim of this paragraph is to analyse the cause of a failure without tester.

**VERY IMPORTANT : The first thing to do is to check if the power to the ETCU and the hydraulic pressure are correct. In every case, you have to do the tests describe in the items "Power supply" and "Hydraulic pressure".**

The tests have to be done on the connectors of the harness.

After every step, you have to plug back the connector which has been used before going on in the tests.

Function	Igni- tion on	Engine run- ning	Procedure	Checking and results	Notes
Power supply (1)	No	No	Disconnect the connector <b>F</b> (black)  Plug on light of 55 W between	Between <b>F4</b> and <b>F6</b> , U = 9 VDC mini Between <b>F5</b> and <b>F6</b> , U = 9 VDC mini <b>F4</b> and the earth, light is on <b>F5</b> and the earth, light is on	If the light is not on, check the fuse 15A (battery)
	No	No	Disconnect the connector <b>A</b> (black)	<b>A22</b> and earth, U = 0 VDC	
	Yes	No		<b>A22</b> and earth, U = 12 VDC	
Hydraulic pressure (2)	No No	No Yes	Disconnect the connector <b>D</b> (brown)	<b>D7</b> and earth, R = ∞ <b>D7</b> and earth, R = 0 Ω	
Differential Lock (3) • Light	No	No	Disconnect the connector <b>C</b> (green)	<b>C2</b> and + battery, diff.lock light on	Check the fuse <b>F11</b> , if the values are incorrect
	Yes	No	Disconnect the connector <b>B</b> (grey)	<b>B2</b> and earth, U = 0 V, swith off <b>B2</b> and earth, U = 12 V, switch on	
	Yes	Yes	Disconnect the solenoid and measure voltage between its two connector lines	U = 0 V, diff.lock switch off U = 12 V, diff.lock switch on	
Brake switches (4)	Yes	No	Unlatch the two pedals. Disconnect the connector <b>A</b> (black)	<b>A17</b> and earth, U = 0 V, brake pedal(s) released <b>A17</b> and earth, U = 12 V, brake pedal(s) depressed	If the values are incorrect, check the fuse <b>F14</b>



11C02.8

## 6100 SERIES TRACTORS

**Autotronic 2 - Checking without tester**

Function	Ignition on	Engine running	Procedure	Checking and results	Notes
<b>4 WD (5)</b> • Light  • Switch  • Solenoid	No	No	Disconnect the connector <b>A</b> (black)	<b>A5</b> and + battery, 4 WD light is on	If the values are incorrect, check fuse <b>F11</b>
	Yes	No	Disconnect the connector <b>B</b> (grey)	<b>B1</b> and earth, U = 12 V, switch on <b>B1</b> and earth, U = 0 V, switch off	
	Yes	Yes	Disconnect the solenoid. Connect a light of 55 W to its connector. Press on the brake pedal(s) and then drive the tractor.	Tractor stopped = 4 WD : the light is off Tractor moving = 2 WD : the light is on	
<b>Lift switch (6)</b>	No	No	Disconnect the connector <b>B</b> (grey)	<b>B4</b> and earth, U = 12 V, switch on lift position <b>B4</b> and earth, U = 0 V, switch on work position or neutral	
<b>Hare/ Tortoise (7)</b> • Light  • Switch  • Solenoid	No	No	Disconnect the connector <b>C</b> (green)	<b>C4</b> and + battery, the Hare light is on	If the values are incorrects, check the fuse <b>F12</b>
	Yes	No	Disconnect the connector <b>C</b> (green)	<b>C1</b> and earth, U = 12 V, lever in its position to change the range <b>C1</b> and earth, U = 0 V, lever released	
	Yes	Yes	Disconnect the solenoid and measure between its two connector lines	Hare, U = 12 V, Hare light on Tortoise, U = 0 V, Hare light off	
<b>PTO (8)</b> • Light  • Switch  • Solenoid  • Low speed engine PTO light	No	No	Disconnect the connector <b>A</b> (black)	<b>A10</b> and + battery : 540 PTO light is on if the PTO switch is on 540 rev/min <b>A10</b> and + battery : 1000 PTO light is on if the PTO switch is on 1000 rev/min	If the values are incorrect, check the fuse <b>F12</b>
	Yes	No	Disconnect the connector <b>B</b> (grey)	<b>B6</b> and earth, U = 0 V, PTO disengaged <b>B6</b> and earth, U = 12 V, PTO engaged	
	Yes	Yes	Disconnect the solenoid and measure voltage between its two connector lines	U = 0 V, PTO released U = 12 V, PTO engaged	
	No	No	Disconnect the connector <b>B</b> (grey). Put the low speed PTO lever in 1550 rpm position	<b>B7</b> and + battery : the low speed PTO light is on	



## Autotronic 2 - Checking without tester

11C02.9

Function	Ignition on	Engine running	Procedure	Checking and results	Notes																				
<b>Speed sensors (9) (10)</b> <ul style="list-style-type: none"> <li>• PTO speed sensor</li> <li>• Forward speed sensor</li> <li>• Engine speed sensor</li> </ul>	No	No	Disconnect the connector <b>D</b> (brown)	Between <b>D1</b> and <b>D2</b> , R = 450 Ω																					
	No	No	Disconnect the connector <b>D</b> (brown)	Between <b>D3</b> and <b>D4</b> , R = 450 Ω																					
	No	No	Disconnect the connector <b>D</b> (brown)	Between <b>D5</b> and <b>D6</b> , R = 450 Ω																					
<b>Dynashift (11)</b> <ul style="list-style-type: none"> <li>• Light</li> <li>• Lever</li> <li>• Solenoid</li> <li>• Temperature sensor</li> </ul>	No	No	Disconnect the connector <b>A</b> (black)	<b>A1</b> and + battery : A light is on <b>A2</b> and + battery : B light is on <b>A3</b> and + battery : C light is on <b>A4</b> and + battery : D light is on																					
	Yes	No	Disconnect the connector <b>A</b> (black) Change the position of the lever for each range and check the voltage between <b>A19</b> , <b>A20</b> , <b>A21</b> and earth	<table border="1"> <thead> <tr> <th></th> <th>A19</th> <th>A20</th> <th>A21</th> </tr> </thead> <tbody> <tr> <td>A</td> <td>0 V</td> <td>0 V</td> <td>0 V</td> </tr> <tr> <td>B</td> <td>12 V</td> <td>0 V</td> <td>0 V</td> </tr> <tr> <td>C</td> <td>12 V</td> <td>12 V</td> <td>0 V</td> </tr> <tr> <td>D</td> <td>12 V</td> <td>12 V</td> <td>12 V</td> </tr> </tbody> </table>		A19	A20	A21	A	0 V	0 V	0 V	B	12 V	0 V	0 V	C	12 V	12 V	0 V	D	12 V	12 V	12 V	If the voltage is 0 V in all positions, check the power supply of the lever (fuse <b>F8</b> and orange line)
	A19	A20	A21																						
A	0 V	0 V	0 V																						
B	12 V	0 V	0 V																						
C	12 V	12 V	0 V																						
D	12 V	12 V	12 V																						
	Yes	Yes	Disconnect the solenoids EV1 and EV2 and measure the voltage between its two connector lines	<table border="1"> <thead> <tr> <th></th> <th>EV1</th> <th>EV2</th> </tr> </thead> <tbody> <tr> <td>A</td> <td>12 V</td> <td>0 V</td> </tr> <tr> <td>B</td> <td>12 V</td> <td>12 V</td> </tr> <tr> <td>C</td> <td>0 V</td> <td>12 V</td> </tr> <tr> <td>D</td> <td>0 V</td> <td>0 V</td> </tr> </tbody> </table>		EV1	EV2	A	12 V	0 V	B	12 V	12 V	C	0 V	12 V	D	0 V	0 V	EV1 : vertical solenoid (ivory line) EV2 : horizontal solenoid (green line)					
	EV1	EV2																							
A	12 V	0 V																							
B	12 V	12 V																							
C	0 V	12 V																							
D	0 V	0 V																							
	No	No	Disconnect the connector F (black)	Between F2 and F3 - R < 10 k Ω if temperature > 0° C - R > 10 k Ω if temperature < 0° C																					
<b>Reverse shuttle (12)</b> <ul style="list-style-type: none"> <li>• Light and buzzer</li> <li>• Switch</li> </ul>	No	No	Disconnect the connector <b>A</b> (black)	<b>A6</b> and + battery : buzzer is on <b>A7</b> and + battery : forward light is on <b>A8</b> and + battery : backward light is on																					
	Yes	No	Disconnect the connector <b>A</b> (black)	<b>A18</b> and earth, U = 0 V, switch released <b>A18</b> and earth, U = 12 V, switch engaged																					



11C02.10

## 6100 SERIES TRACTORS

**Autotronic 2 - Checking without tester**

Function	Ignition on	Engine running	Procedure	Checkings and Results	Notes
<ul style="list-style-type: none"> <li>• Solenoid</li> </ul>	Yes	Yes	<p><b>Forward speed</b> Drive in reverse speed Preselect the forward speed. Disconnect the forward solenoid and measure the voltage between its two connector lines.</p> <p><b>Reverse speed</b> Drive in forward speed Preselect the reverse speed. Disconnect the reverse solenoid and measure the voltage between its two connector lines.</p>	<p>U = 0 V, clutch pedal released U = 12 V, as long as clutch pedal is pressed</p> <p>U = 0 V, clutch pedal released U = 12 V, as long as clutch pedal is pressed</p>	<p>The forward solenoid is located at the front of the selector cover.</p> <p>The reverse solenoid is located at the rear of the selector cover.</p>
<ul style="list-style-type: none"> <li>• Position sensor</li> </ul>	Yes	No	Disconnect the sensor	<p>R = 4 k <math>\Omega</math> in forward speed R = 2,2 k <math>\Omega</math> in reverse between yellow and green wires</p>	
<p><b>Speedshift (13)</b></p> <ul style="list-style-type: none"> <li>• Light</li> <li>• Lever</li> <li>• Solenoid</li> </ul>	No Yes Yes	No No Yes	<p>Disconnect the connector <b>A</b> (black)</p> <p>Disconnect the connector <b>A</b> (black) Put the lever in C range then D</p> <p>Disconnect the solenoid and measure the voltage between its two connector lines</p>	<p><b>A3</b> and + battery : C light is on <b>A4</b> and + battery : D light is on</p> <p><b>A21</b> and earth, U = 0 V, in C range <b>A21</b> and earth, U = 12 V in D range</p> <p><b>Tractor in 30 Kph except 6180</b> U = 0 V in C range U = 12 V in D range</p> <p><b>Tractor in 40 Kph, 6180 in 30 Kph or 40 Kph :</b> U = 12 V in C range U = 0 V in D range</p>	<p>If the voltage is 0 V in both positions, check the power supply of the lever (orange line and <b>F8</b> fuse)</p>



## 11C03 Checking with tester

### CONTENTS

A.	<b>Symbols (Icons)</b> _____	2
B.	<b>Connecting the tester</b> _____	2
C.	<b>Operating procedure in case of failure</b> _____	2
D.	<b>Using the "Test" function</b> _____	4
E.	<b>"Monitoring" function</b> _____	5
F.	<b>"Testing" function</b> _____	24





11C03.2

## 6100 SERIES TRACTORS

**Autotronic 2 - Checking with tester****A. Symbols (Icons)**

Each function and the various components of the Autotronic 2 system are identified by symbols, as follows:

**Functions**

4 WD



Diff. Lock



PTO

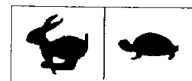

Hare/Tortoise

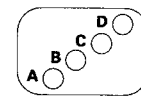

Dynashift

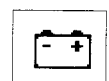

Battery

Hydraulic  
pressure

Clutch



Brakes

Slow  
SpeedshiftFast  
Speedshift

Lift

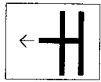
Gear  
leverEngine  
speed

Temperature

Low  
speed PTOForward  
speedReverse  
shuttle**Components**

Switch



Light



Solenoid

**B. Connecting the tester**

Carry out connection 1, 2 or 4. See section 11 A01.3.

**C. Operating procedure in case of failure**

In case of failure, use the following procedure.



# Autotronic 2 - Checking with tester

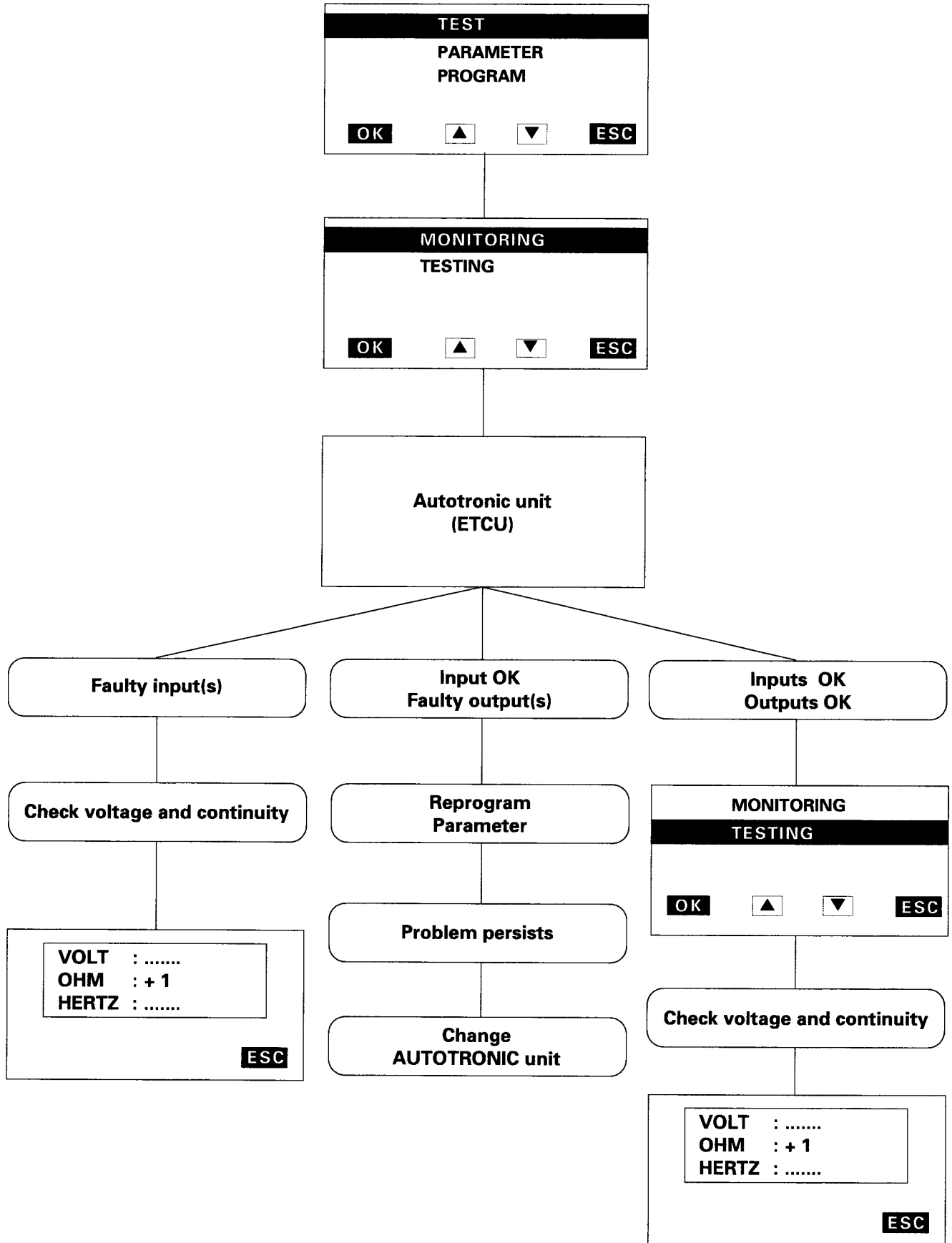



11C03.4

---

## 6100 SERIES TRACTORS

---



# Autotronic 2 - Checking with tester

## D . Using the «Test» function

### Testing

See paragraph F, page 24.

The main «test» function should be used for troubleshooting. It is made up of two secondary functions:

- monitoring,
- testing.

### Monitoring

#### 1. Access conditions

- With the engine running and the hydraulic pressure light out, operate all the Autotronic functions one by one.
- Drive the tractor to check the safety systems concerning forward speed.

#### 2. Principle

Each screen display shows the status of the input and output signals read or transmitted by the TCU.

The symbol for a switch is black when contact is closed.

The symbol for an indicator light or solenoid is black when that component is supplied with 12 V by the TCU.

Sensors for engine speed, forward speed and PTO speed indicate the values measured by the TCU:

- engine speed in rpm,
- forward speed in 0.1 kph,
- PTO speed in rpm (behind the clutch, not the speed of the implement).

Apart from power supply problems, there are three types of operating fault, as follows:

**1. Faulty input:** The TCU does not receive the input signal and, therefore, the outputs remain unchanged.

**2. Faulty output:** The TCU transmits a correct output signal but the corresponding component of the tractor (indicator light or solenoid) does not react. Carry out testing on the outputs.

**3. Faulty TCU:** The TCU reads the right inputs but does not supply power to the right outputs.

It is also possible that an internal connection may be broken (resulting in correct output on the tester but absence of current on the TCU output terminal).



## Autotronic 2 - Checking with tester

### E . "Monitoring" function

This function monitors Autotronic's internal working.

**Use the keyboard to access to the monitoring function.**

The tester screen shows the symbols (icons) corresponding to the various components whose functions are being tested, and these change colour whenever an input or output is activated.

Meaning of symbols

Example : A16

A = connector A on ETCU

16 = pin 16

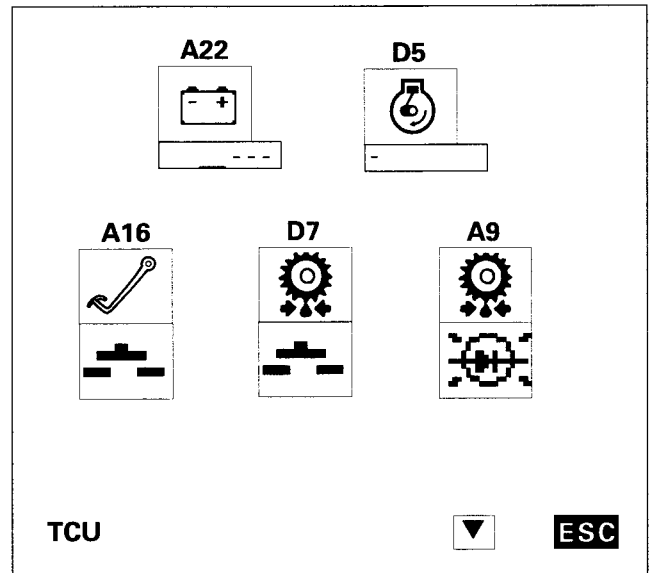

### Power supply and warning lights

Symbol	Description
A22	Supply voltage
D5	Engine speed
A16	Clutch switch
D7	Hydraulic pressure switch
A9	Hydraulic pressure light

This initial screen shows all the input signals required for the ETCU to switch to «WORK» mode. If these signals are incorrect, there is no point in continuing the test procedure.

INSTRUCTION	ON TESTER	ON TRACTOR
Start up engine and keep clutch pedal pressed down	Clutch switch <b>A16 on</b> Pressure switch <b>D7 on</b> Engine speed sensor <b>operating</b> Pressure light <b>A9 off</b> Mode TCU 4	4WD light <b>on</b> Pressure light <b>off</b> Hare light <b>on</b> and speed range solenoid <b>powered</b>
Release clutch pedal	Clutch switch <b>A16 off</b> Pressure switch <b>D7 on</b> Engine speed sensor <b>operating</b> Pressure light <b>A9 off</b> Mode TCU 4	4WD light <b>on</b> Pressure light <b>off</b> Hare light <b>on</b> and speed range solenoid <b>operating</b>



11C03.6

---

 6100 SERIES TRACTORS
 

---



## Autotronic 2 - Checking with tester

In case of operating fault "ON TESTER", see below.  
 In case of operating fault "ON TRACTOR", see Testing.

### Operating faults

- 1. Battery:** The tester does not check the Autotronic power supply. This operation must be carried out separately before connecting the tester. The screen shows the voltage supplied from the alternator (ignition switched on) and read by the ETCU on terminal **A22** of the harness.
- 2. Clutch switch :** Measure the resistance between terminal **A16** of the tractor harness and the earth terminal :  
 Correct value  $R = 0$  to  $1.5 \Omega$  : pedal pressed down, switch closed  
 Operating fault  
 If  $R = \text{infinity}$  : pedal released, switch open. Check line continuity and connection on the starter motor.
- 3. Low hydraulic pressure switch :** Measure the resistance between terminal **D7** of the tractor harness and the earth terminal:  
 Correct value  $R = 0 \Omega$  : switch is closed (engine running, pressure OK)  
 Operating fault  
 If  $R = \text{infinity}$  : switch is open (engine stopped, accumulator discharged, no pressure)  
 Check switch directly. Check resistance of green wire and earth connection (black wire).
- 4. Engine speed sensor signal :** Measure the resistance between **D5** and **D6** of the tractor harness :  
 Correct value  $R = 450 \Omega \pm 10 \Omega$   
 If  $R = \text{correct}$ , adjust the sensor and use the frequency measurement to check that the sensor is working.  
 See 9I01.14 (6100) and 9F01.9 or 9R01.6 (8100).  
 If  $R = 0$  or infinity, check the continuity of lines **D5** and **D6**.
- 5. TCU mode :** The TCU switches from mode TCU 4 to TCU 6 and then 7 if there is a problem with engine speed, and from mode TCU 5 to 2 if there is a switch problem.

TCU 1	: problem with software
TCU 5 - 2	: low pressure problem, see switch, earth wire
TCU 6 - 7	: engine signal problem, see engine speed sensor, adjustment, wires
TCU 9 or 10	: incorrect parameters or no parameters
TCU 11	: battery voltage too high
TCU 12	: TCU is in testing mode. Engine signal is required to exit from this mode.



# Autotronic 2 - Checking with tester

11C03.7

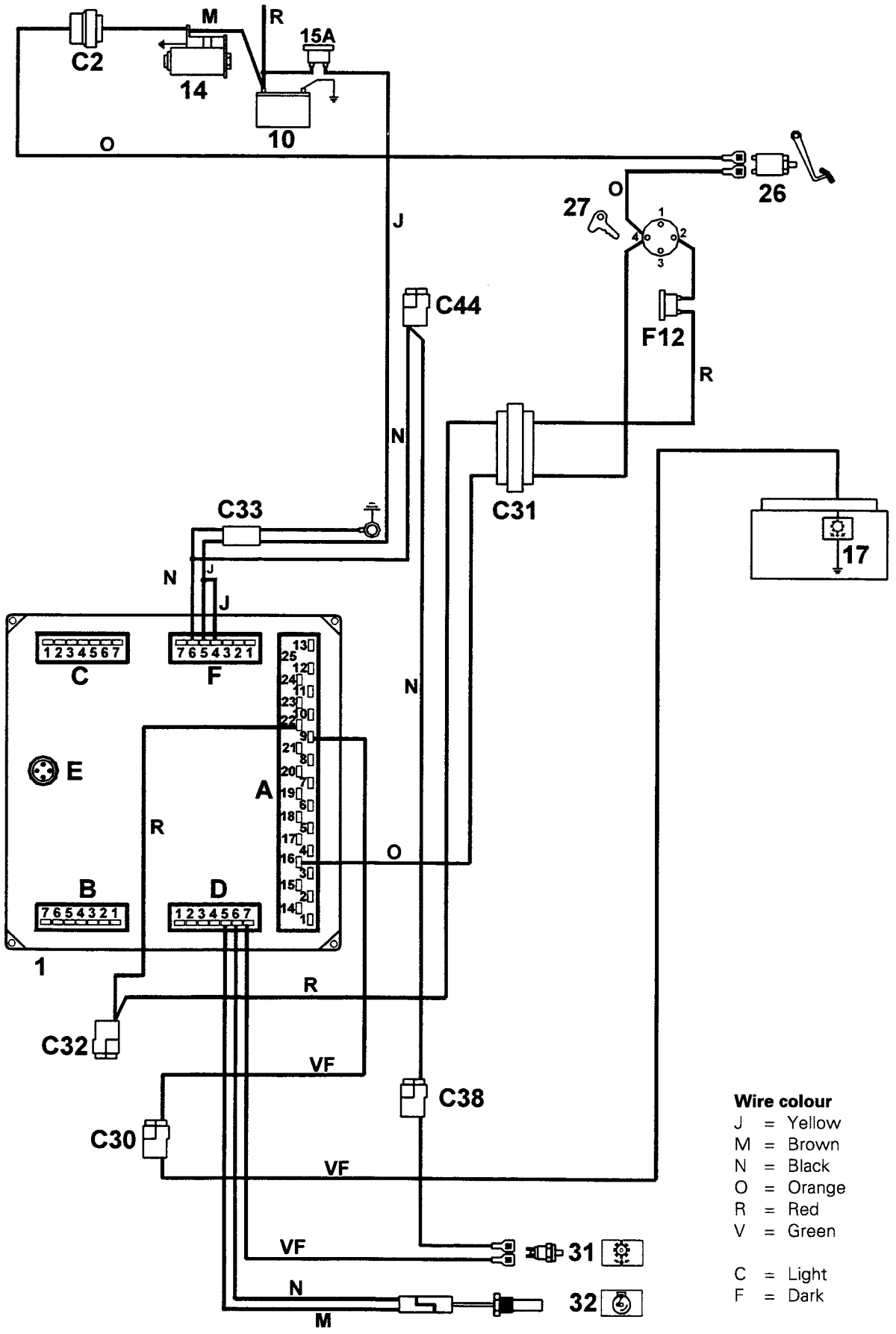



11C03.8

## 6100 SERIES TRACTORS

**Autotronic 2 - Checking with tester**

## Hare/Tortoise range

Symbol	Description
C1	Switch
C4	Solenoid - Light
A9	Hydraulic pressure light
D3	Forward speed

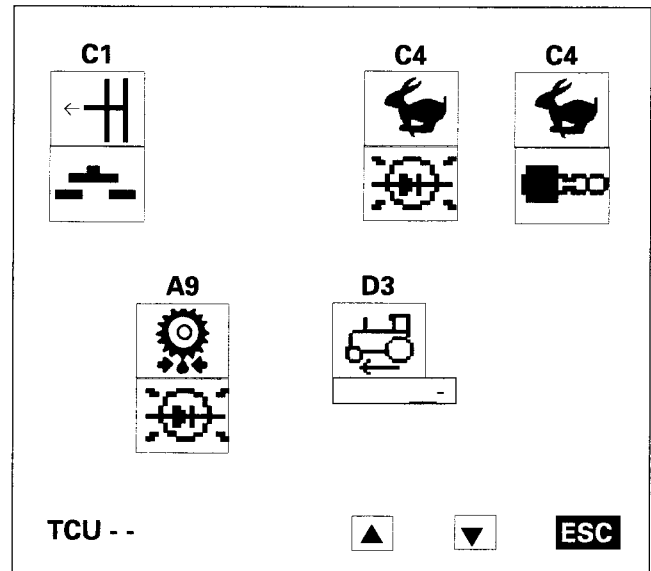

INSTRUCTION	ON TESTER	ON TRACTOR
Select range change by moving the lever	Speed in kph = 0 Range switch <b>C1 on</b> while holding lever in position	
Check that the range changes after each action on the lever	<b>Hare</b> Hare light <b>C4 on</b> Range solenoid <b>C4 on</b> <b>Tortoise</b> Hare light <b>C4 off</b> Range solenoid <b>C4 off</b> Pressure light <b>A9 off</b>	<b>Hare</b> Hare light <b>on</b> Range solenoid <b>powered</b> <b>Tortoise</b> Hare light <b>on</b> Range solenoid <b>non powered</b>
Drive the tractor at more than 10 kph Select a range change Check that the range remains unchanged	Speed = + 10 kph  The range switch <b>C1 comes on</b> but the range does not change	No change

**Operating faults**

**1. Range switch** : Check the voltage on terminal **C1** of the tractor harness

V = 12 volts when the switch is closed (pressed)

V = 0 volt when the switch is open (released)

If not, check the switch power supply (fuse, etc.), the switch and line continuity.

**2. Forward speed signal** : Using an ohmmeter, measure the resistance between **D3** and **D4** of the tractor harness:

Correct value R = 450 Ω. If R = correct ensure that the sensor is operating by measuring the frequency and checking its setting, see § 6B01.9 (6100) or 6E01.7 (8100).

If R = 0 or infinity, check the continuity of lines **D3** and **D4**.

**3. Range lights and solenoid** : Perform testing.







11C03.10

## 6100 SERIES TRACTORS

**Autotronic 2 - Checking with tester**

## 4WD

Symbol	Description
B1	4WD switch
A5	4WD warning light
C6	Solenoid
A17	Brake switches
A9	Hydraulic pressure light
D3	Forward speed

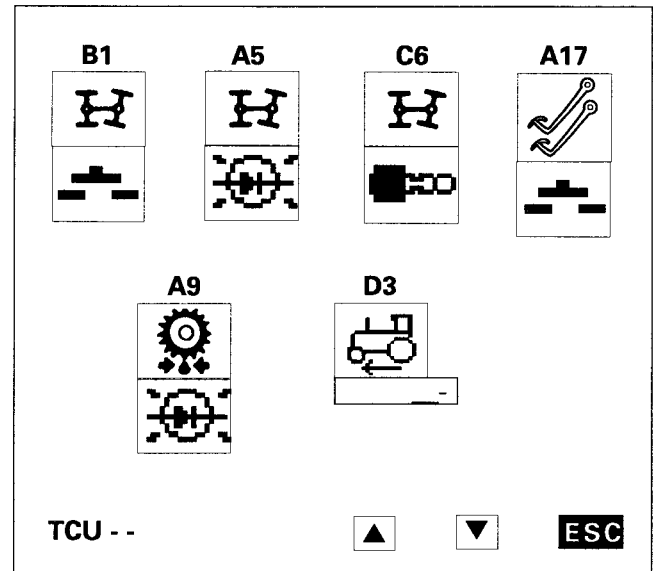

INSTRUCTION	ON TESTER	ON TRACTOR
Press the 4 WD button on instrument panel, press the brake pedals in turn	Brake switch <b>A17 on</b> while pressing pedals V = 0 kph Pressure light <b>A9 off</b>	4WD light <b>stays on</b> 4WD solenoid <b>not power-supplied</b> Pressure light <b>off</b>
Press the 4WD button once.	4WD switch <b>B1 on</b> while pressing button 4WD light <b>A5 goes out</b> V = 0 kph Pressure light <b>A9 off</b>	4WD light <b>goes out</b> 4WD solenoid <b>not power-supplied</b> Pressure light <b>off</b>
Drive the tractor and check that the 4WD transmission is disengaged	A signal <b>is transmitted</b> by the forward speed sensor The 4WD solenoid <b>C6 comes on</b> V = more than 0 kph	4WD light <b>stays out</b> 4WD solenoid is <b>power-supplied</b> (front axle disengaged)

**Operating faults****1. 4WD switch** : Check the voltage on terminal **B1** of the tractor harness

V = 12 volts when the switch is closed (pressed)

V = 0 volt when the switch is open (released)

If not, check the switch power supply (fuse, etc.), the switch and line continuity.

**2. Brake switches** : Check the voltage on terminal **A17** of the tractor harness

V = 12 volts when the pedal is pressed and the switch is closed

V = 0 volt when the pedal is released and the switch is open

If not, check the power supply to the brake switches (fuse, etc.), the switches and line continuity.

**Note : If the brake switches are open, it is impossible to disengage the 4WD transmission.****3. Forward speed signal** : Measure the resistance between **D3** and **D4** on the tractor harness :

See fault 2, page 8.

**4. 4WD light and solenoid** : Perform testing.



# 6100 SERIES TRACTORS



## Autotronic 2 - Checking with tester

11C03.11

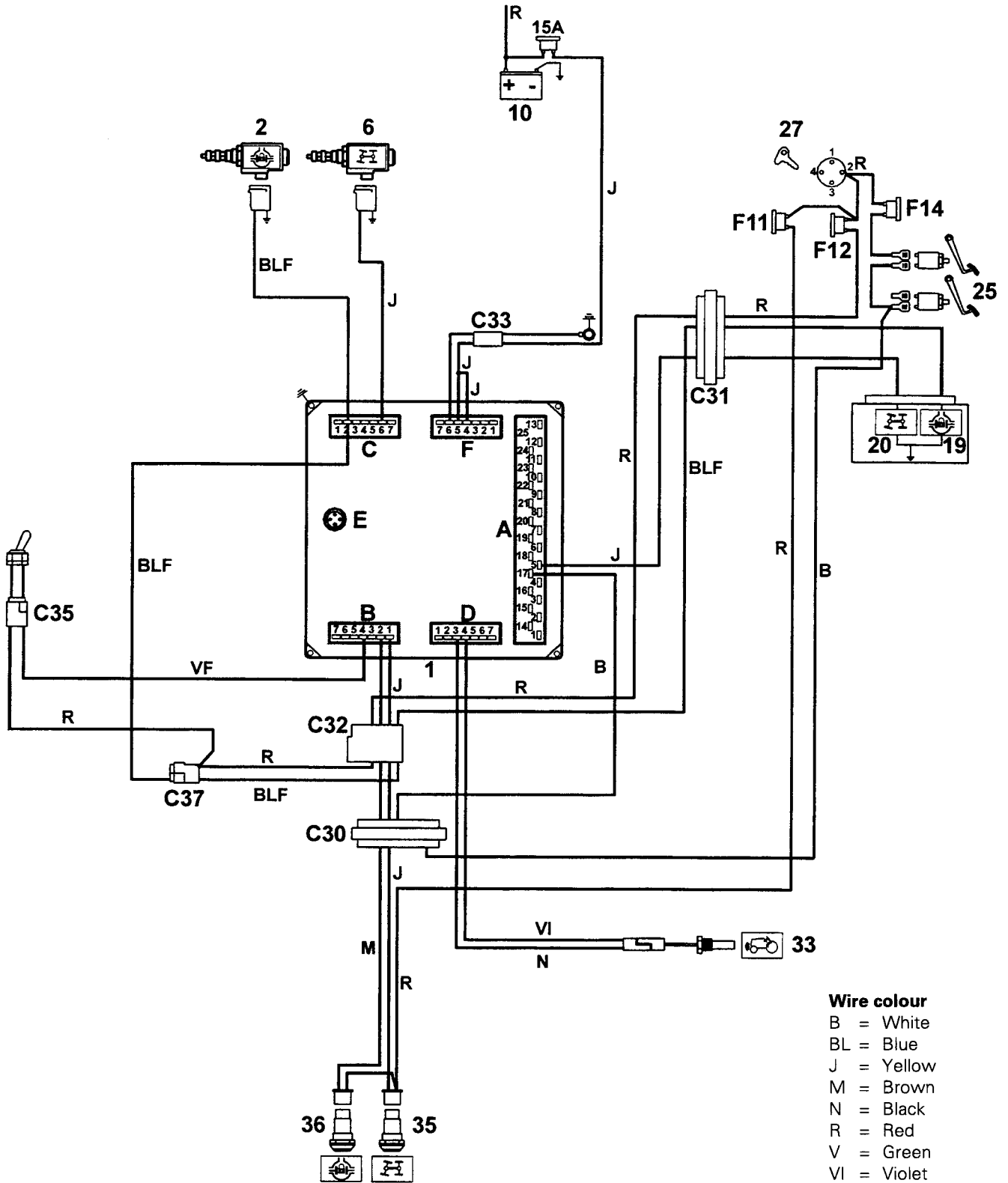

### Wire colour

- B = White
- BL = Blue
- J = Yellow
- M = Brown
- N = Black
- R = Red
- V = Green
- VI = Violet

- C = Light
- F = Dark



11C03.12

## 6100 SERIES TRACTORS

**Autotronic 2 - Checking with tester**

## Differential lock

Symbol	Description
B2	Switch
C2	Warning light and solenoid
A17	Brake switch
B4	Lift switch
A9	Hydraulic pressure light
D3	Forward speed

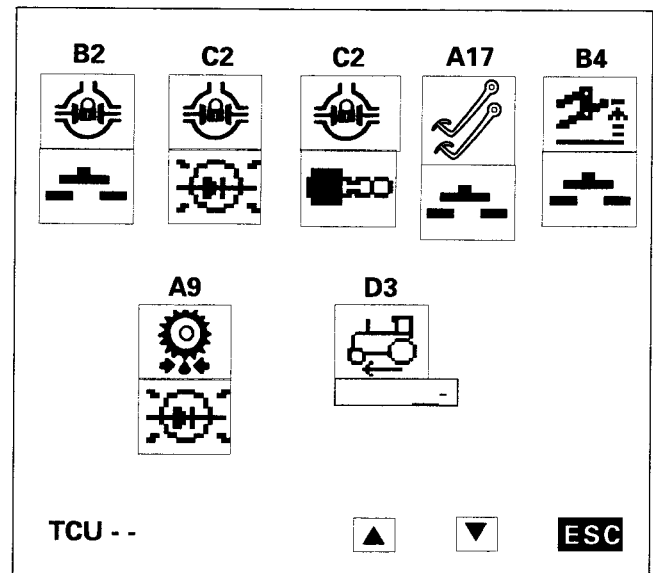

- The 4WD light comes on automatically when starting the engine.

INSTRUCTION	ON TESTER	ON TRACTOR
Press the Diff.Lock once. Lift switch on the down position	Diff.Lock switch <b>B2 on</b> while pressing the button Diff.Lock light <b>C2 comes on</b> Diff.Lock solenoid <b>C2 comes on</b> Pressure light <b>A9 off</b> V = 0 kph	Diff.Lock light <b>comes on</b> Diff.Lock solenoid <b>is power-supplied</b> Pressure light <b>off</b>
Press the brake pedals in turn	Brake switch <b>A17 comes on</b> Diff.Lock light <b>C2 goes out</b> Diff.Lock solenoid <b>C2 goes out</b> V = 0 kph Pressure light <b>A9 off</b>	Diff.Lock light <b>goes out</b> Diff.Lock solenoid <b>is no longer power-supplied</b> Pressure light <b>off</b>
Release the brake pedals	Brake switch <b>A17 comes off</b> Diff.Lock light <b>C2 comes on</b> Diff.Lock solenoid <b>C2 comes on</b> Pressure light <b>A9 off</b> V = 0 kph	Diff.Lock light <b>comes on</b> Diff.Lock solenoid <b>is power-supplied</b> Pressure light <b>off</b>
Set the lift switch to the up position (transport)	Lift switch <b>B4 comes on</b> Diff.Lock light <b>C2 goes out</b> Diff.Lock solenoid <b>C2 goes out</b> V = 0 kph	Diff.Lock light <b>goes out</b> Diff.Lock solenoid <b>is no longer power-supplied</b>
Set the lift switch to the down position	Lift switch <b>B4 goes out</b> Diff.Lock light <b>C2 comes on</b> Diff.Lock solenoid <b>C2 goes out</b> V = 0 kph	Diff.Lock light <b>comes on</b> Diff.Lock solenoid <b>is power-supplied</b>
Drive the tractor along at more than 14 kph	Forward speed signal is <b>OK</b> Diff.Lock light <b>C2 goes out</b> Diff.Lock solenoid <b>C2 goes out</b> V = 0 kph	Diff.Lock light <b>goes out</b> Diff.Lock solenoid <b>is no longer power-supplied</b>



## Autotronic 2 - Checking with tester

11C03.13

### Operating faults

- 1. Diff.Lock switch** : Check the voltage on terminal **B2** of the tractor harness

V = 12 volts when the switch is closed (pressed)

V = 0 volt when the switch is open (released)

If not, check the switch power supply (fuse, etc.), the switch and line continuity.

- 2. Brake switches** : Check the voltage on terminal **A17** of the tractor harness

V = 12 volts when the pedal is pressed and the switch closed

V = 0 volt when the pedal is released and the switch open

If not, check the power supply to the brake switches (fuse, etc.), the switch and the continuity of switches and lines.

**Note: If the brake switches are open, it is impossible to disengage the 4WD transmission.**

- 3. Lift switch** : Check the voltage on terminal **B4** of the tractor harness

V = 12 volts when the switch is closed (lift in up position)

V = 0 volt when the switch is open (lift in down or neutral position)

If not, check the switch power supply (fuse, etc.), the switch and line continuity.

- 4. Diff.Lock light and solenoid** : Perform testing.

- 5. Forward speed signal** : Measure the resistance between **D3** and **D4** of the tractor harness

If R = 450  $\Omega$ , the correct value, adjust the sensor and use the frequency measurement to check that the sensor is working.

If R = 0 or infinity, check the continuity of lines **D3** and **D4**.

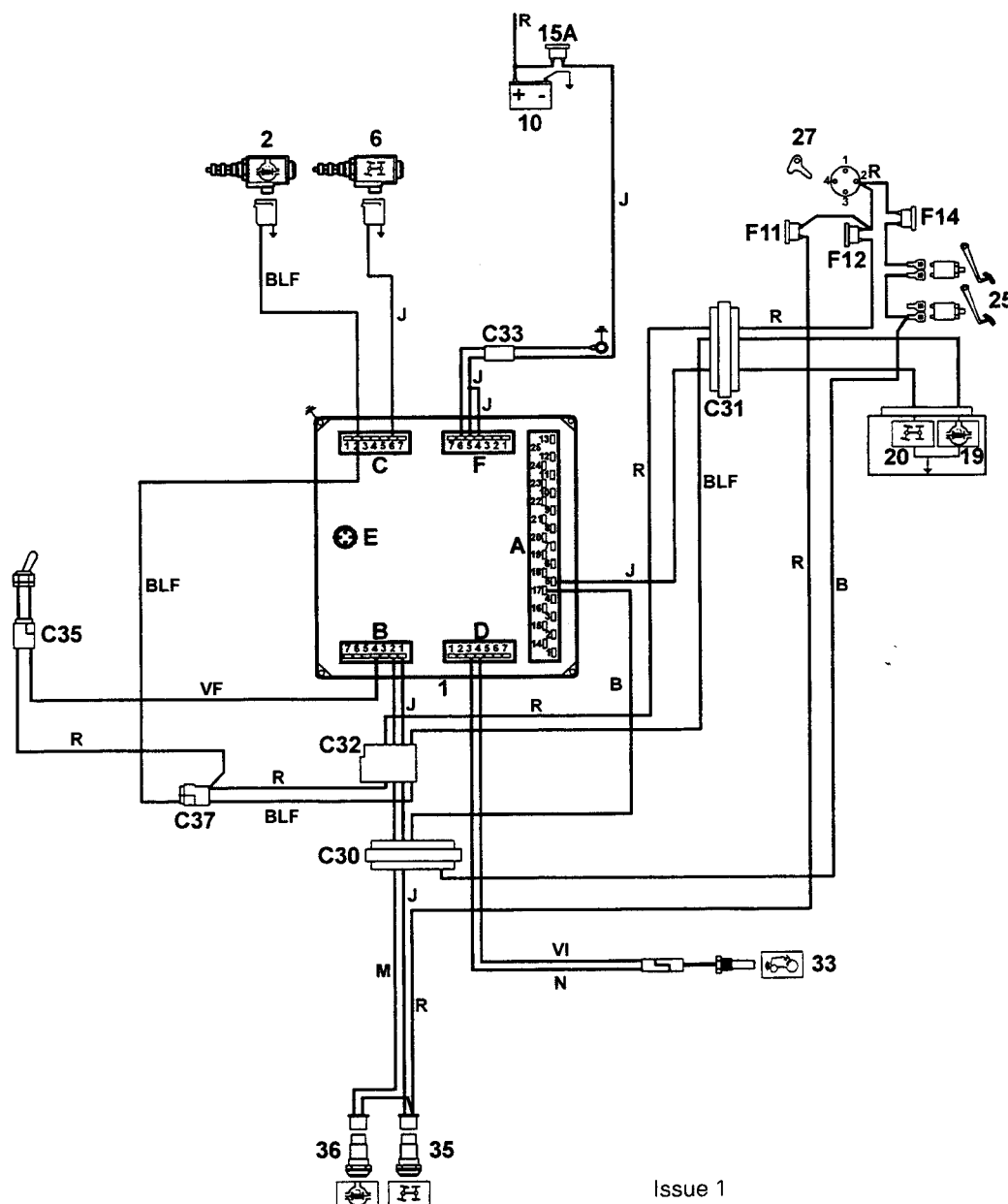

#### Wire colour

B = White  
 BL = Blue  
 G = Grey  
 J = Yellow  
 M = Brown  
 N = Black  
 O = Orange  
 R = Red  
 V = Green  
 VI = Violet

C = Light  
 F = Dark



11C03.14

## 6100 SERIES TRACTORS

**Autotronic 2 - Checking with tester**

## PTO

Symbol	Description
B6	PTO switch
A10	PTO warning light
C5	Solenoid
B7	PTO low speed switch
A9	Hydraulic pressure light
D1	PTO speed
D5	Engine speed

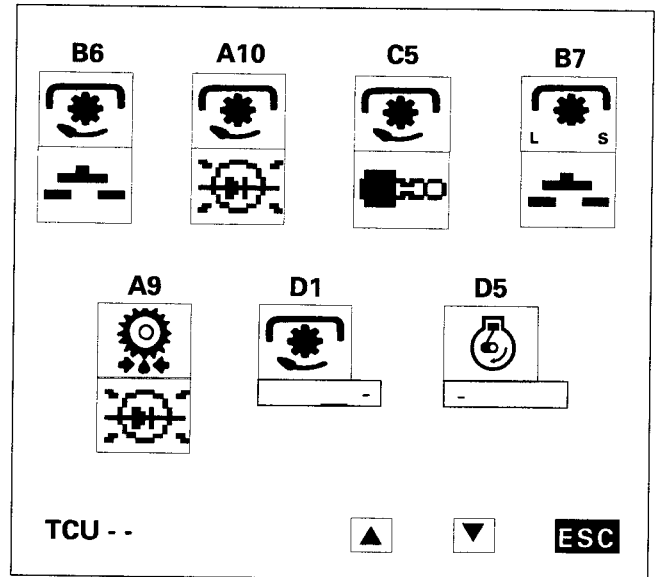

INSTRUCTION	ON TESTER	ON TRACTOR
Engage the PTO	PTO switch <b>B6</b> comes on PTO light <b>A10</b> comes on PTO solenoid <b>C5</b> comes on PTO speed sensor <b>operating</b> PTO speed <b>is displayed</b> PTO speed = engine speed * Low speed PTO <b>B7</b> switch is off	PTO light <b>comes on</b> PTO solenoid is <b>power-supplied</b>
Disconnect the PTO speed sensor After 5 seconds, the PTO should stop rotating	PTO switch <b>B6</b> stays on PTO light <b>A10</b> flashes PTO solenoid <b>C5</b> goes out Engine speed <b>is displayed</b> PTO speed = 0 immediately Low speed PTO switch <b>B7</b> is off	PTO light <b>flashes</b> PTO solenoid <b>is no longer power-supplied</b> PTO <b>stops</b> rotating
Disengage the PTO Reconnect the PTO speed sensor		
<b>On 6100 series only :</b> Select low speed PTO and engage the PTO	PTO switch <b>B6</b> comes on PTO light <b>A10</b> comes on PTO solenoid <b>C5</b> comes on Engine speed <b>is OK</b> PTO speed = engine speed * Low speed PTO switch <b>B7</b> comes on	Low speed PTO light <b>comes on</b> PTO light <b>comes on</b> PTO solenoid <b>is power-supplied</b>
Increase the engine speed to over 2,000 rpm The PTO should stop rotating	PTO switch <b>B6</b> stays on PTO light <b>A10</b> flashes PTO solenoid <b>C5</b> goes out PTO speed = 0 Engine speed <b>is OK</b> Low speed PTO switch <b>B7</b> goes out	Low speed PTO light is on PTO light <b>flashes</b> PTO solenoid <b>is no longer power-supplied</b> PTO <b>stops</b> rotating

\* **The PTO speed read on the tester is not the speed on the output shaft but the speed calculated on output from the PTO clutch.**



## Autotronic 2 - Checking with tester

### Operating faults

1. **PTO switch** : Check the voltage on terminal **B6** of the tractor harness  
 V = 12 volts when the switch is closed (PTO engaged)  
 V = 0 volt when the switch is open (PTO stopped)  
 If not, check the switch power supply (fuses, etc.), the switch and line continuity.
2. **Low speed PTO switch** : Check the voltage on terminal **B7** of the tractor harness  
 V = 12 volts when the PTO is engaged and the switch is closed  
 V = 0 volt when the PTO is stopped and the switch is open  
 If not, check the switch power supply (fuses, etc.), the switch and line continuity.
3. **Engine speed signal** : Measure the resistance between **D5** and **D6** of the tractor harness  
 See fault 4 p. 6.
4. **PTO speed sensor signal** : Measure the resistance between **D1** and **D2** of the tractor harness.  
 Correct value R = 450  $\Omega$   
 If R = correct ensure that the sensor is operating by measuring the frequency and checking its setting (see 11B04p8).  
 If R = 0 or infinity, check the continuity of lines **D1** and **D2**.  
 If the engine speed and PTO speed are different, this indicates a bad parameter or clutch slippage.
5. **PTO light and solenoid** : Perform testing.

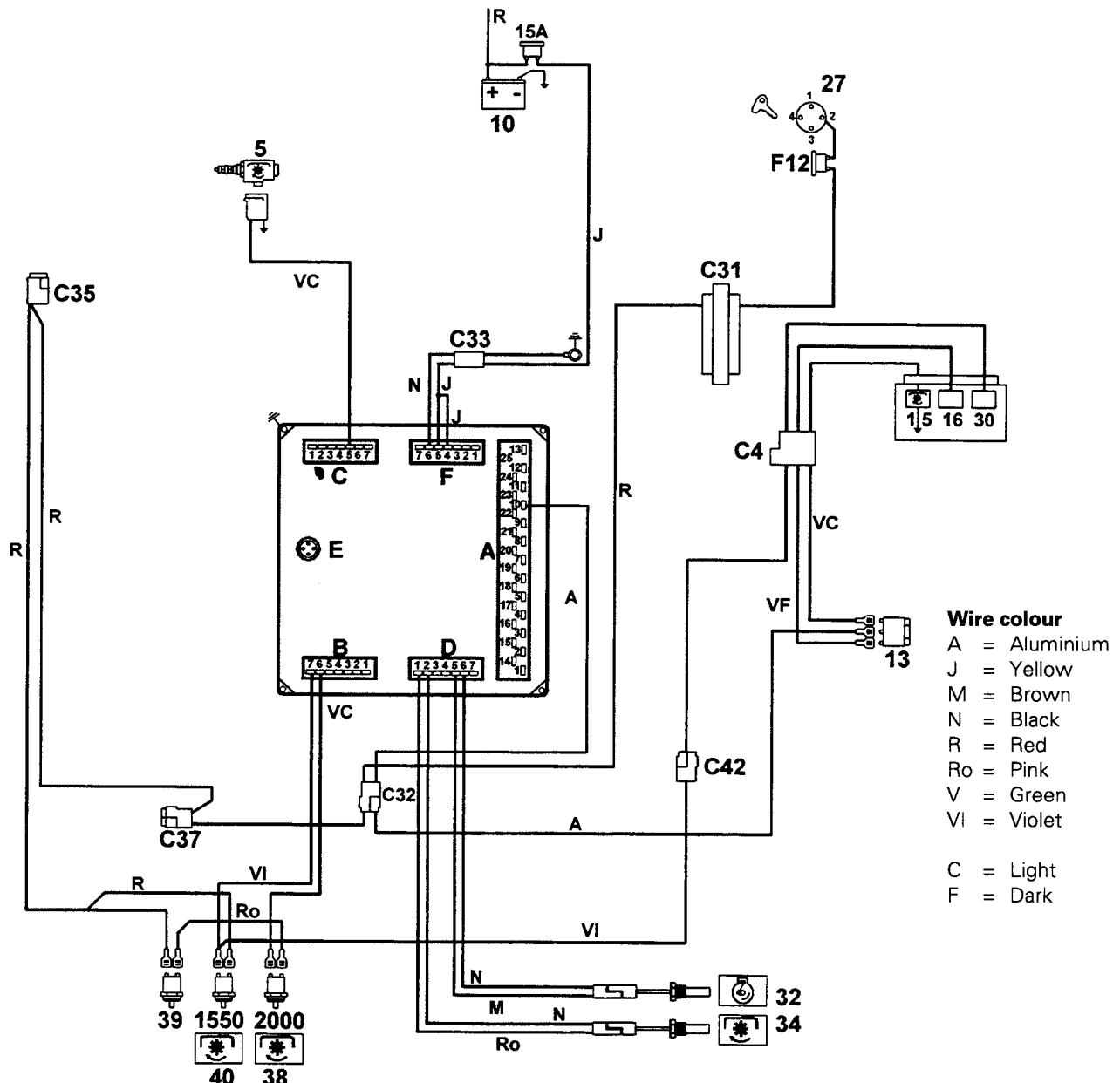



11C03.16

## 6100 SERIES TRACTORS

**Autotronic 2 - Checking with tester**

## Hydro-electrical reverse shuttle (6100)

Symbol	Description
A18	Forward reverse shuttle switch
B2	Diff.Lock switch
C1	Hare/Tortoise switch
A16	Clutch switch
D3	Forward speed sensor
A7	Reverse shuttle warning light (forward)
A14	Reverse shuttle solenoid (reverse)
A8	Reverse shuttle warning light (reverse)
A23	Reverse shuttle solenoid (forward)
A15	Sensor - Reverse shuttle piston

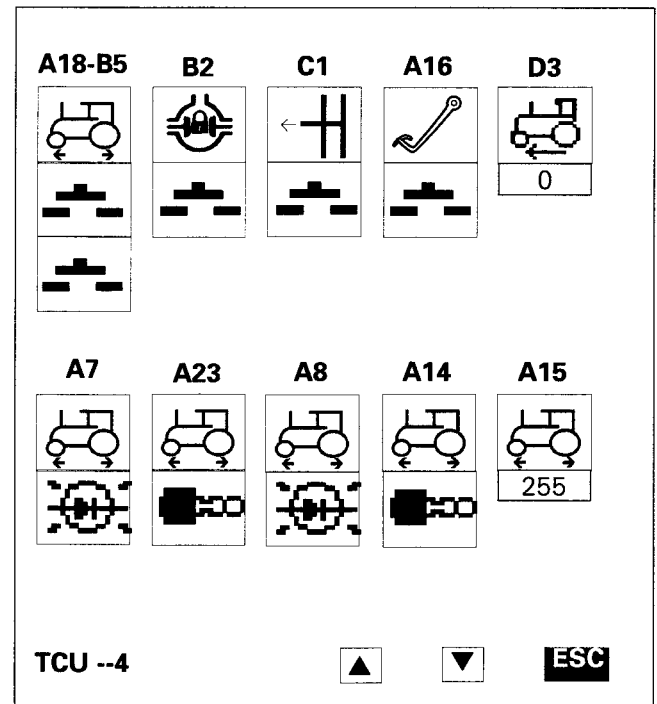

INSTRUCTION	ON TESTER	ON TRACTOR
Pre-select the forward speed with the lever	<b>A18 on</b> (during moving of the lever) <b>A7 flashes</b> <b>A8 on</b> <b>A14 and A23 off</b> <b>A15</b> gives the fork position	Reverse shuttle light - Reverse <b>on</b> Reverse shuttle light - Forward <b>flashes</b> Buzzer rings
Disengage the clutch	<b>A16 on</b> (when declutching) <b>A7 on</b> <b>A8 off</b> <b>A23 on during 2 s</b> <b>A15</b> gives new position of the fork	Reverse shuttle light - Reverse <b>on</b> Reverse shuttle light - Forward <b>off</b> Forward solenoid powered about 2 s Buzzer off
Pre-select the reverse speed with the lever	<b>A18 on</b> (during moving of the lever) <b>A7 on</b> <b>A8 flashes</b> <b>A14 and A23 off</b> <b>A15</b> gives the fork position	Reverse shuttle light - Reverse <b>flashes</b> Reverse shuttle light - Forward <b>on</b> Buzzer rings
Disengage the clutch	<b>A16 on</b> (when declutching) <b>A7 off</b> <b>A8 on</b> <b>A14 on during about 2 s</b> <b>A15</b> gives new position of the fork	Reverse shuttle light - Reverse <b>on</b> Reverse shuttle light - Forward <b>off</b> Reverse solenoid powered about 2 s Buzzer off



# Autotronic 2 - Checking with tester

11C03.17

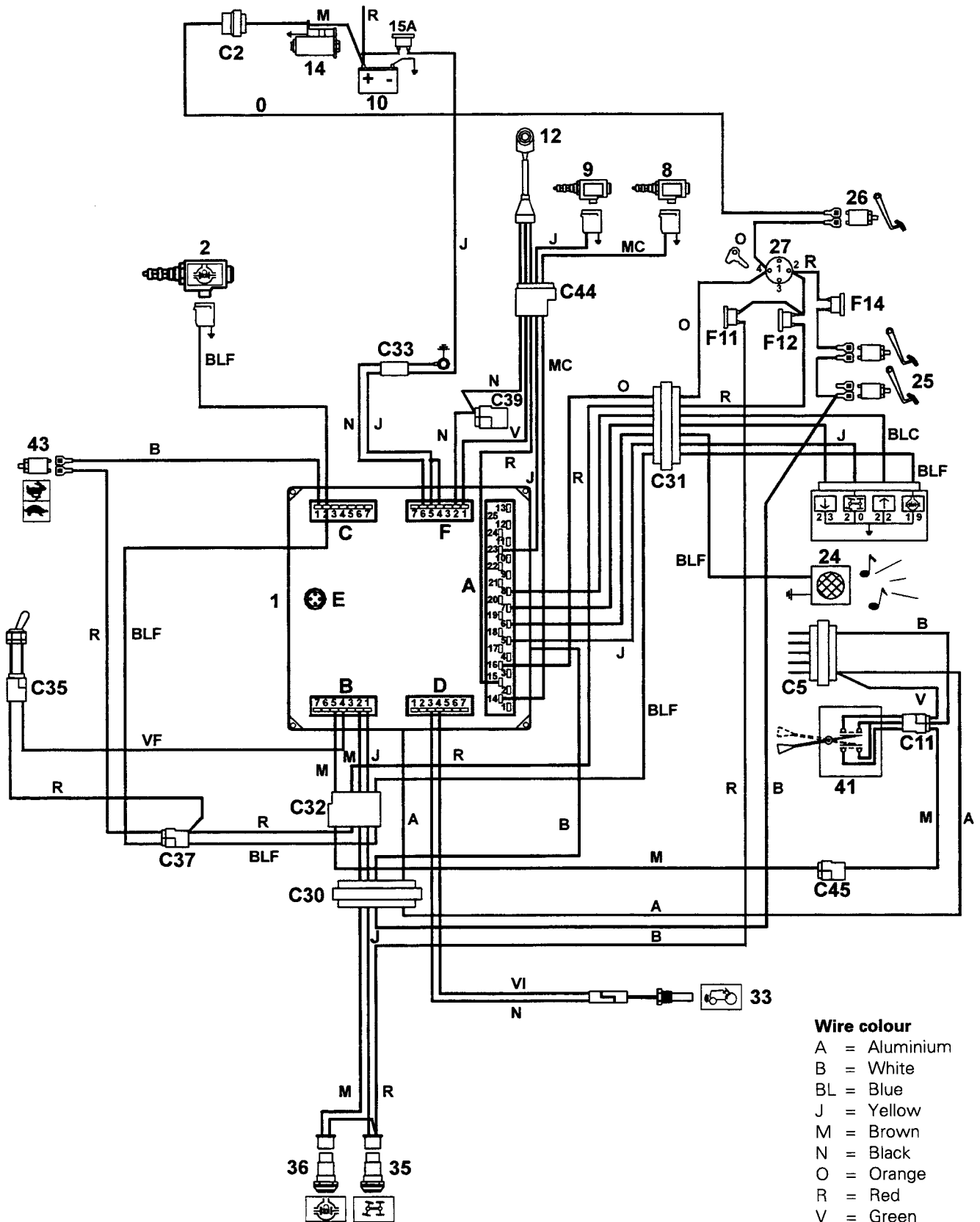

- Wire colour**
- A = Aluminium
  - B = White
  - BL = Blue
  - J = Yellow
  - M = Brown
  - N = Black
  - O = Orange
  - R = Red
  - V = Green
  - VI = Violet
- 
- C = Light
  - F = Dark





11C03.18

---

 6100 SERIES TRACTORS
 

---



## **Autotronic 2 - Checking with tester**

### Operating faults

**1. Reverse shuttle lever (switch) :** Ignition on, check the voltage on pins of the 3 way-connector **C11** located at the rear of the instrument panel.

White wire : forward = 12 V

reverse = 12 V

Brown wire : forward = 12 V

reverse = 0 V

Green wire : forward = 0 V

reverse = 12 V

If these values are not obtained, check the switch power supply (fuse, etc...) the switch and the line continuity.

**2. Diff.Lock switch**

See p. 13

**3. Hare/Tortoise switch**

See p. 8

**4. Clutch switch**

See p. 6

**5. Forward speed sensor**

See p. 8

**6. Reverse shuttle piston sensor**

If the value **A15** displayed on the tester = 0 in reverse or forward check :

- voltage on green wire F1, about 10 volts

If value of A15 does not change check :

- voltage on red wire varies

If not, check the sensor power supply, the sensor and the line continuity.



## Autotronic 2 - Checking with tester

11C03.19

### Dynashift

Symbol	Description
A19	Dynashift lever input
A20	Dynashift lever input
A21	Dynashift lever input
A1	Range A light
A2	Range B light
A3	Range C light
A4	Range D light
C3	Solenoid EV2
C7	Solenoid EV1
A9	Hydraulic pressure light
F3	Temperature sensor
D3	Forward speed
D5	Engine speed

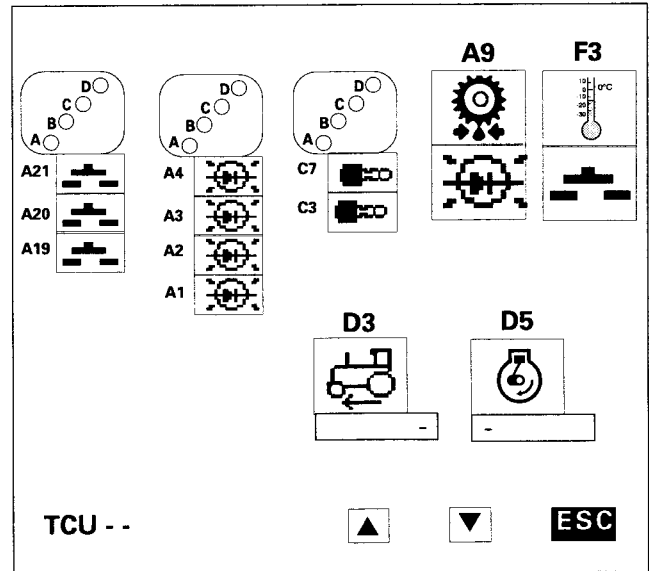

INSTRUCTION	ON TESTER	ON TRACTOR
	Engine speed sensor operating Temperature sensor is operating and remains black for the following tests:	
Select ratio A	Switch <b>A19 off</b> Switch <b>A20 off</b> Switch <b>A21 off</b> Light <b>A1 on</b> Solenoid <b>C7 on</b> Solenoid <b>C3 off</b>	Light <b>A on</b> Solenoid 1 <b>power-supplied</b> Solenoid 2 <b>not power-supplied</b>
Select ratio B	Switch <b>A19 on</b> Switch <b>A20 off</b> Switch <b>A21 off</b> Light <b>A2 on</b> Solenoid <b>C7 on</b> Solenoid <b>C3 on</b>	Light <b>B on</b> Solenoid 1 <b>power-supplied</b> Solenoid 2 <b>power-supplied</b>
Select ratio C	Switch <b>A19 on</b> Switch <b>A20 on</b> Switch <b>A21 off</b> Light <b>A3 on</b> Solenoid <b>C7 off</b> Solenoid <b>C3 on</b>	Light <b>C on</b> Solenoid 1 <b>not power-supplied</b> Solenoid 2 <b>power-supplied</b>
Select ratio D	Switch <b>A19 on</b> Switch <b>A20 on</b> Switch <b>A21 on</b> Light <b>A4 on</b> Solenoid <b>C7 off</b> Solenoid <b>C3 off</b>	Light <b>D on</b> Solenoid 1 <b>not power-supplied</b> Solenoid 2 <b>not power-supplied</b>
Drive the tractor	Forward speed sensor <b>D3 operating</b>	
Disconnect temperature sensor	Temperature sensor <b>F3 off</b>	



11C03.20

## 6100 SERIES TRACTORS

**Autotronic 2 - Checking with tester****Operating faults****1. Dynashift switch**

Check the voltage on terminals **A19**, **A20** and **A21**

	<b>A19</b>	<b>A20</b>	<b>A21</b>
<b>Ratio A</b>	0	0	0
<b>Ratio B</b>	12 V	0	0
<b>Ratio C</b>	12 V	12 V	0
<b>Ratio D</b>	12 V	12 V	12 V

**IF NOT** : Check the power supply to the lever switch **C5** (orange wire from relay: 12 V with engine running) and check lever output lines.

	<b>Black</b>	<b>Brown</b>	<b>Red</b>
<b>Ratio A</b>	0	0	0
<b>Ratio B</b>	12 V	0	0
<b>Ratio C</b>	12 V	12 V	0
<b>Ratio D</b>	12 V	12 V	12 V

- 2. Clutch switch** : Measure the resistance between terminal **A16** of the tractor harness and the earth  
 R = 0 to 1.5  $\Omega$  when the pedal is pressed and the switch is closed  
 R = infinity when the pedal is released and the switch closed. Check line continuity and connection to the starter motor.
- 3. Engine speed sensor signal**: Measure the resistance between **D5** and **D6** of the tractor harness :  
 See page 6
- 4. Forward speed signal** : Measure the resistance between **D3** and **D4** of the tractor harness :  
 See page 8
- 5. Temperature sensor**  
 If lights **A** and **D** are flashing, this indicates LOW temperature or open circuit.  
 Check the resistance between **F2** and **F3** of the harness:  
 R = infinity = lines broken  
 R less than 10 k $\Omega$  = correct if temperature higher than 0°C  
 R more than 10 k $\Omega$  and temperature higher than 0°C,  
     check resistance of lines  
     change sensor  
 R = 0 = short-circuit
- 6. DYNASHIFT lights and solenoids** : Perform testing.



**Autotronic 2 - Checking with tester**

11C03.21

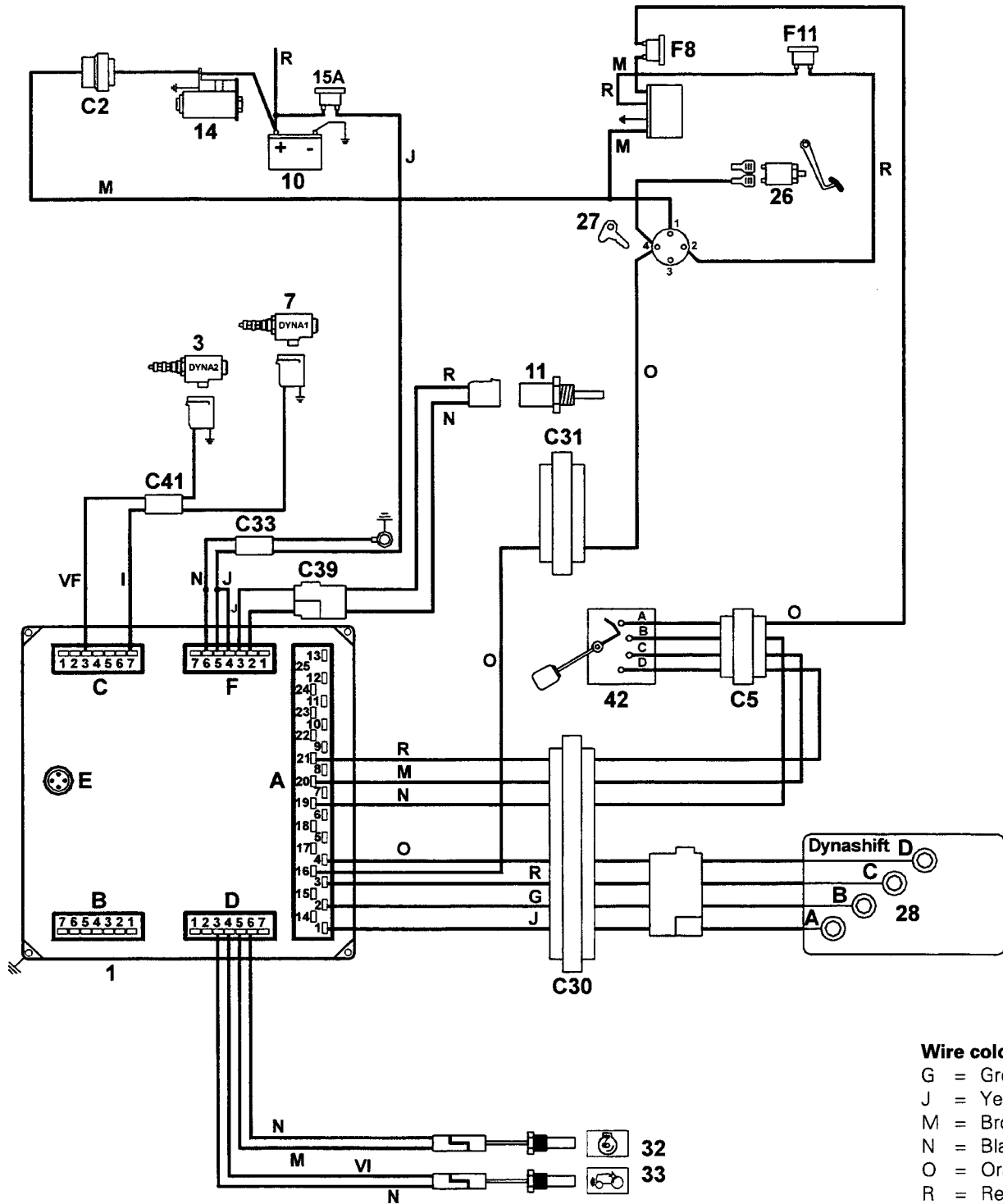

**Wire colour**

- G = Grey
- J = Yellow
- M = Brown
- N = Black
- O = Orange
- R = Red
- V = Green
- VI = Violet

- C = Light
- F = Dark



11C03.22

## 6100 SERIES TRACTORS

**Autotronic 2 - Checking with tester****Speedshift**

Symbol	Description
A21	Switch
A3	Low range light
A4	High range light
C3	Solenoid
A9	Hydraulic pressure light
D3	Forward speed
D5	Engine speed

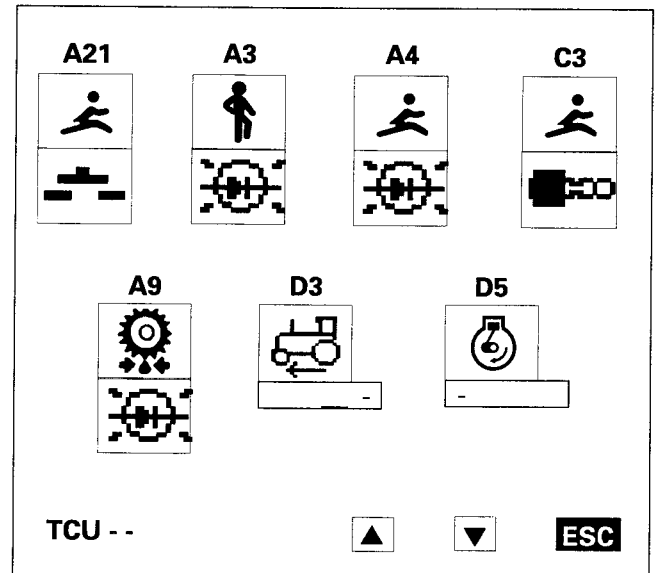

INSTRUCTION	ON TESTER	ON TRACTOR
Press Speedshift button	V = 0 kph Speedshift switch <b>A21 on</b> when button pressed	
Check that the Speedshift changes from high range to low range and back again	<p><b>Speedshift 30 kph</b> Hi light <b>A4 on</b> with Speedshift solenoid <b>C3 on</b></p> <p>Lo light <b>A3 on</b> with Speedshift solenoid <b>C3 off</b></p> <p><b>Speedshift 40 kph</b> Hi light <b>A4 on</b> with Speedshift solenoid <b>C3 off</b></p> <p>Lo light <b>A3 on</b> with Speedshift solenoid <b>C3 on</b></p>	<p><b>Speedshift 30 kph</b> Hi light <b>on</b> with Speedshift solenoid <b>power-supplied</b></p> <p>Lo light <b>on</b> with Speedshift solenoid <b>not power-supplied</b></p> <p><b>Speedshift 40 kph</b> Hi light <b>on</b> with Speedshift solenoid <b>not power-supplied</b></p> <p>Lo light <b>on</b> with Speedshift solenoid <b>power-supplied</b></p>

**Operating faults****1. Speedshift switch**Check the voltage at terminal **A21**

V = 12 V when the switch is closed

V = 0 V when the switch is open

If not, check the switch power supply, the switch and the resistance of the line connected to the ETCU

**2. Speedshift light and solenoid** : Perform testing.



Autotronic 2 - Checking with tester

11C03.23

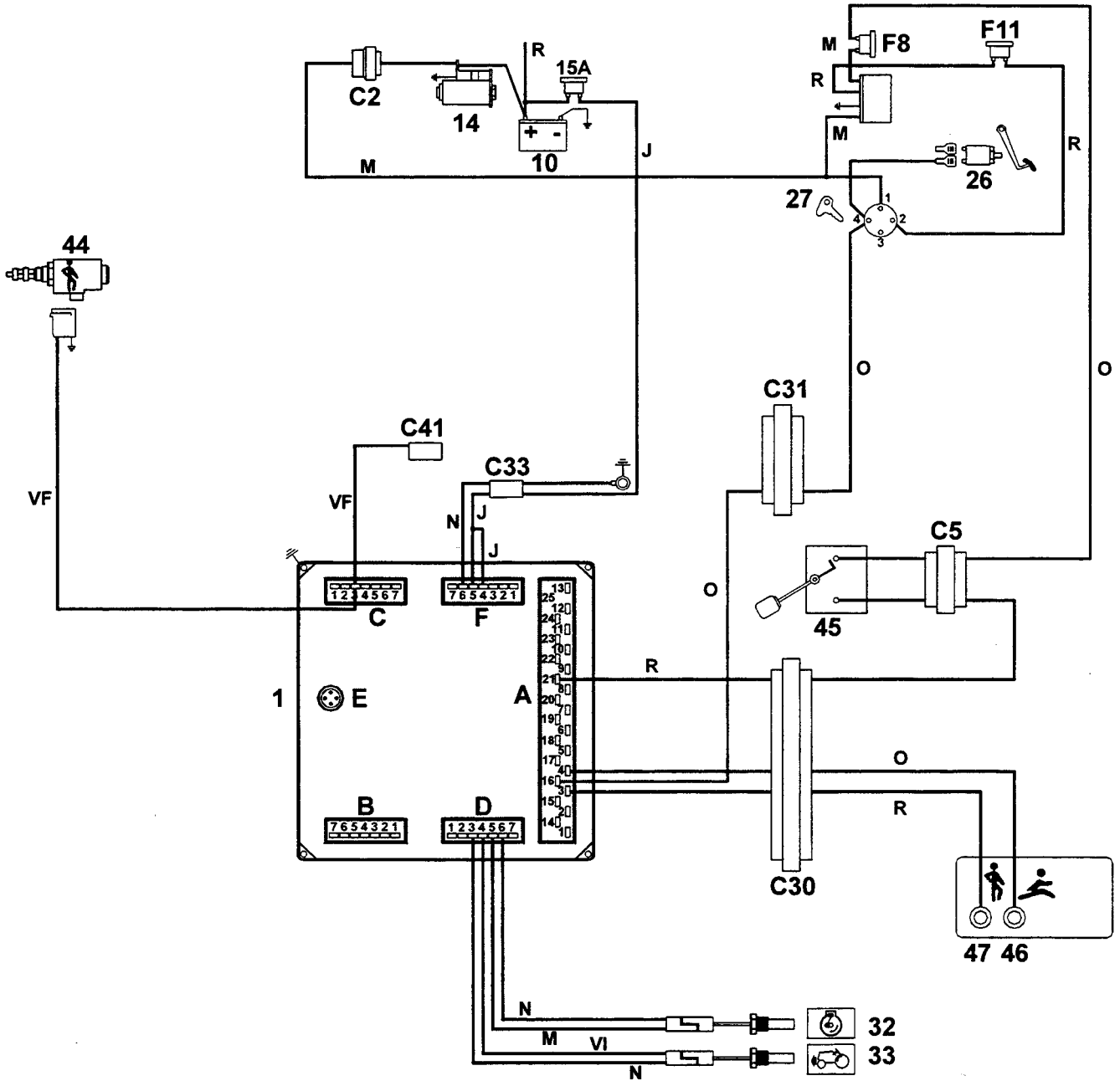

Wire colour

- J = Yellow
- M = Brown
- N = Black
- O = Orange
- R = Red
- V = Green
- VI = Violet

- C = Light
- F = Dark



11C03.24

6100 SERIES TRACTORS



Autotronic 2 - Checking with tester

F . "Testing" function

1. Access conditions

With the engine stopped, hydraulic pressure light on, and ignition switched on.

Press the clutch pedal to hold the TCU in alarm mode.

- "OFF" is displayed under symbol **D5** indicating that the engine is stopped.
- "OFF" is displayed under symbol **A9** indicating that there is no hydraulic pressure.
- "ON" is displayed under symbol **A22** indicating that the ignition is switched on. The supply voltage (11.9 V) is also displayed.

2. Principle

The tester forces operation of all Autotronic outputs one by one. It analyses the current draw to detect unconnected or short-circuited components. The component symbol (solenoid or light) on the tester goes black when the output is power-supplied. As soon as an anomaly is detected, "ERR" is displayed under the symbol for the faulty output.

**Important : The tester cannot be used to check :**

- LEDs owing to their low current draw,
- PTO and 4 WD solenoids for purely electronic reasons. Question marks are displayed indicating that the voltage must be checked directly on the solenoid.

Access to the function "Testing" using the keyboard.

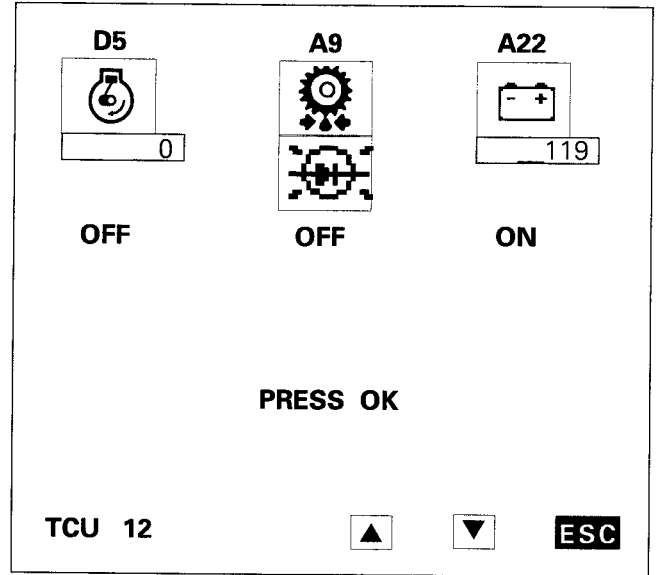

If these values are correct, the TCU switches to "Diagnostic" mode (TCU 12). Press OK to go on to the test procedure. Use the arrows to go on to the next screen.

Screen 2: Hare/Tortoise

On tester	On tractor
Hare light changes status	Hare light is illuminated on instrument panel
Solenoid changes status	Solenoid is energised
Hydraulic pressure light changes status	Hydraulic pressure light is illuminated
Solenoid changes status but "ERR" is displayed	Measure resistance between earth and output C4 Correct value = $10 \Omega \pm 2$
The hare light changes status but is not illuminated on control panel	Check light line and faulty light

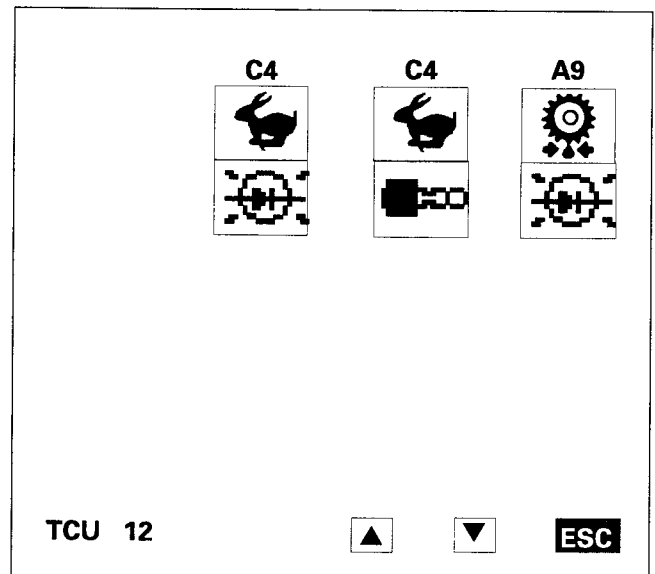



## Autotronic 2 - Checking with tester

11C03.25

### Screen 3 : 4WD

On tester	On tractor
4WD light changes status	4WD light is illuminated on instrument panel
Solenoid changes status and two question marks are displayed	Solenoid is normally energised
Light changes status but «ERR» is displayed	Check light line and light
Solenoid changes status with two question marks	Measure resistance between earth and output C6 Normal value = $10 \Omega \pm 2$

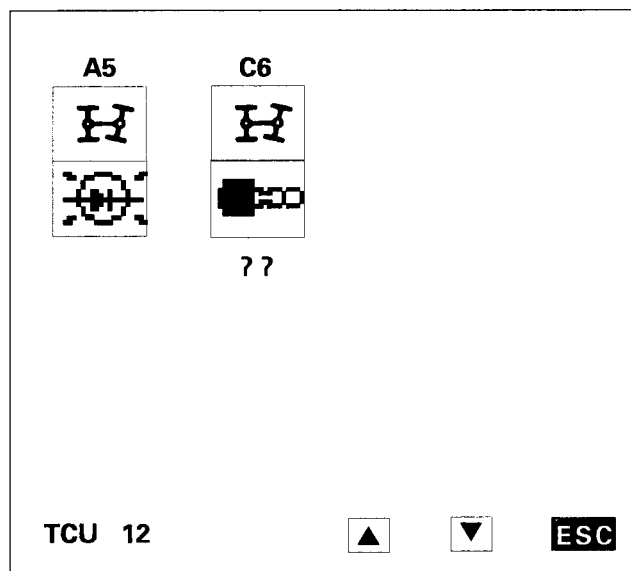

### Screen 4 : PTO

On tester	On tractor
PTO switch changes status	Engage PTO lever in cab
PTO light changes status	PTO light changes status on instrument panel
Solenoid changes status	Solenoid is energised
Switch status does not change	Check switch input
Light changes status but is not illuminated on instrument panel	Check light line and light
Solenoid changes status but "ERR" is displayed	Measure resistance between earth and output C5 Normal value = $10 \Omega \pm 2$

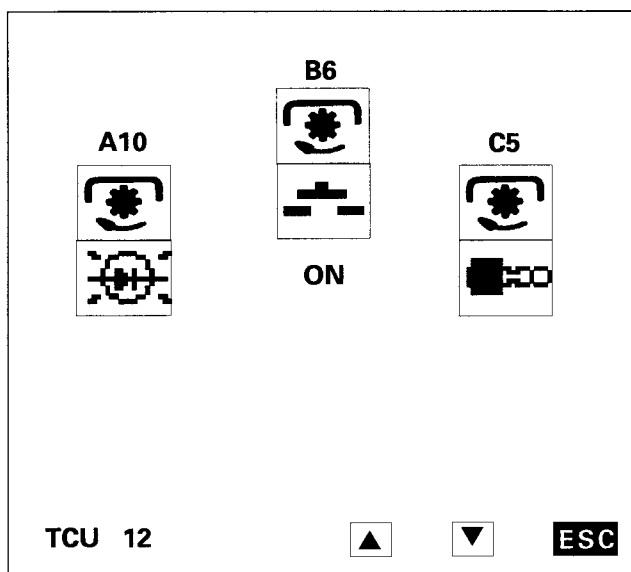

### Screen 5 : Differential lock

On tester	On tractor
Diff.Lock light and solenoid change status	Diff.Lock light changes status on instrument panel and solenoid is energised
Light and solenoid change status but «ERR» is displayed	Measure resistance between earth and output C2 Correct value = $5.9 \Omega$ as the light and solenoid are connected in parallel
If C32 is disconnected and «ERR» is displayed, there is a problem on light	To differentiate between problem on light or solenoid, disconnect C32

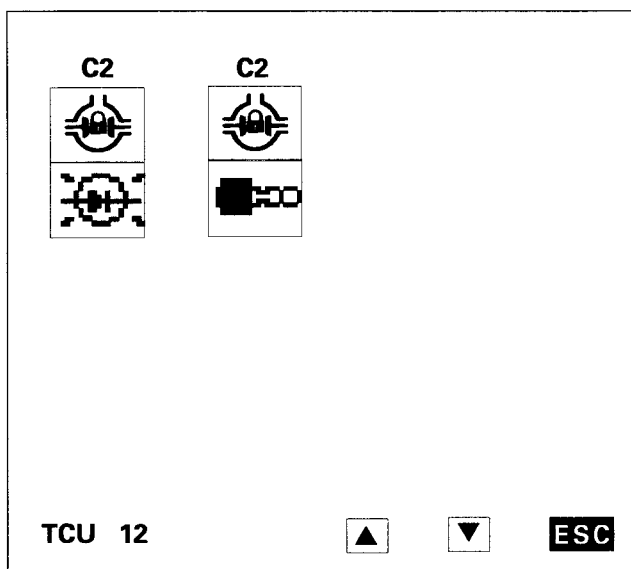





## 6100 SERIES TRACTORS



11C03.26

### Autotronic 2 - Checking with tester

#### Screen 6 : Hydro-electrical reverse shuttle

on tester	on tractor
Forward light <b>A7</b> changes status	The green forward light comes on on the instrument panel
The forward solenoid <b>A23</b> changes status. Three question marks are displayed under the icon to mean that the tester is unable to test it	The forward solenoid is energised
The reverse shuttle light <b>A8</b> changes status	The red reverse shuttle light comes on on the instrument panel
The reverse shuttle solenoid <b>A14</b> changes status	The reverse shuttle solenoid is energised
The buzzer <b>A6</b> changes status	The buzzer rings

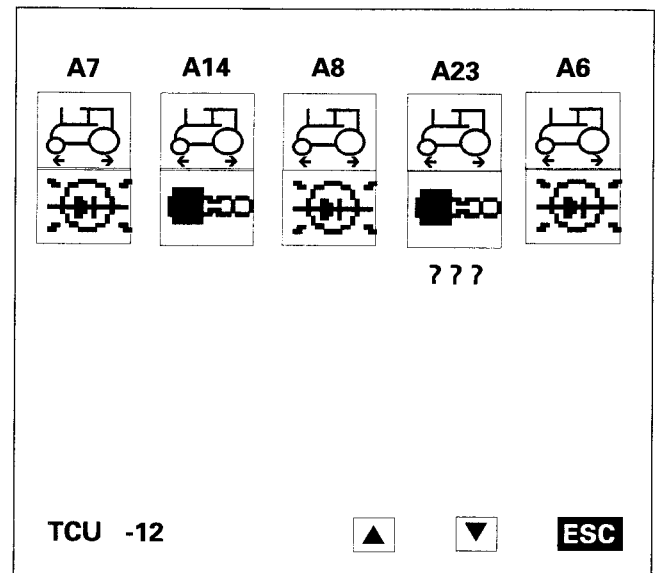

**Nota :** Like the PTO and 4 WD solenoids the tester cannot check the forward solenoid.



# Autotronic 2 - Checking with tester

## Screen 7 : Dynashift

On tester	On tractor
Light <b>A1</b> changes status	Light A is illuminated on instrument panel
Light <b>A2</b> changes status	Light B is illuminated on instrument panel
Light <b>A3</b> changes status	Light C is illuminated on instrument panel
Light <b>A4</b> changes status	Light D is illuminated on instrument panel
Solenoid EV1 <b>C7</b> changes status	Solenoid is energised
Solenoid EV2 <b>C3</b> changes status	Solenoid is energised
One of the lights changes status but is not illuminated on instrument panel	Check light lines and lights
Solenoid EV1 changes status but "ERR" is displayed	Measure resistance between earth and output C7 Normal value = $10 \Omega \pm 2$
Solenoid EV2 changes status but "ERR" is displayed	Measure resistance between earth and output C3 Normal value = $10 \Omega \pm 2$

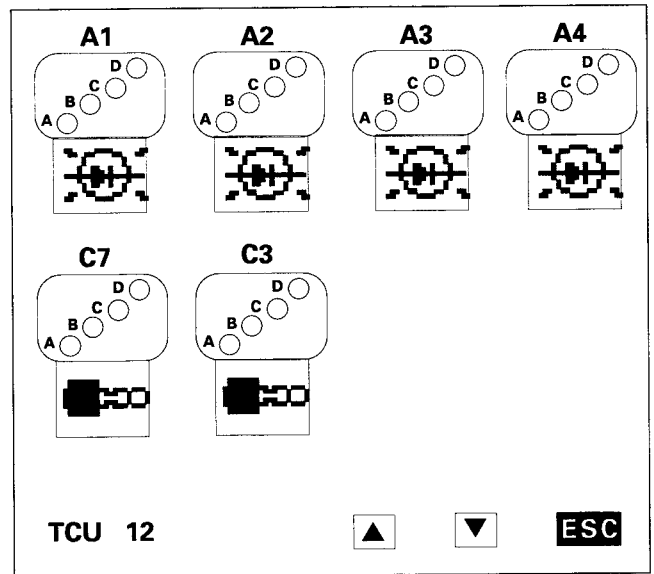

## Screen 8 : Speedshift

On tester	On tractor
Low range light changes status	Low range light is illuminated on instrument panel
High range light changes status	High range light is illuminated on instrument panel
Solenoid changes status to high range except 6180 <b>Warning for MF 6180,</b> solenoid is only energised in low range	Solenoid is energised
One of the two lights changes status but is not illuminated on instrument panel	Check light lines and lights
Solenoid status does not change	Measure resistance between earth and output C3 Normal value = $10 \Omega \pm 2$

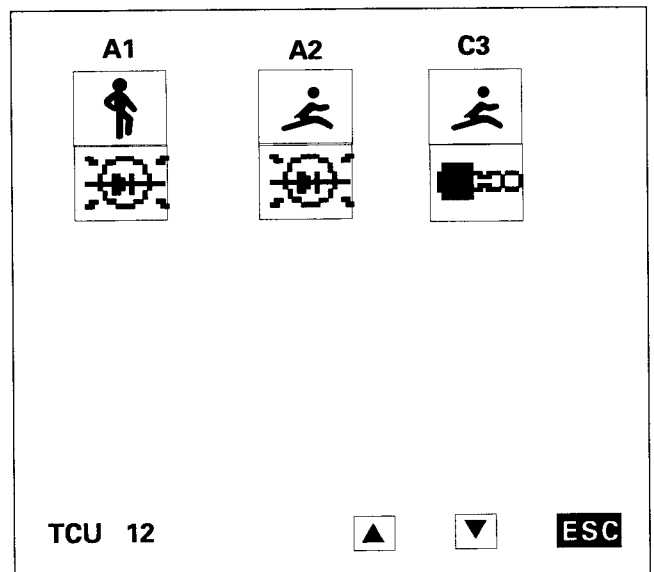





## 11 C04 Parameters

### CONTENTS

A. Screens	_____	2
B. Key to parameters	_____	3



**When setting parameters on the electronic transmission control unit (ETCU), always ensure that you comply with the local road speed limit.**



11C04.2

## 6100 SERIES TRACTORS

**Autotronic 2 - Parameters****A. Screens**

Select PARAMETER.

Press the clutch pedal to activate the electronic transmission control unit (ETCU). The tester checks that the ETCU is at issue Y. If it is, the parameter screen is displayed.

The ETCU will then be locked in this mode. Indicator lights will remain in the same state (on or off) as when the tester started this procedure.

OLD: current parameters of the ETCU  
NEW: parameters to be entered

TYPE NEW CODE THEN PRESS OK.

The tester checks whether the code is known.  
If it is known, the line «CODE OK?» is displayed.  
Press OK to send the code to the ETCU.

Once the parameters have been recorded by the ETCU, it is automatically reset with the new parameters.  
IF THE CODE IS UNKNOWN TO THE TESTER: the message «ERR» is displayed. The cursor flashes on the erroneous figure.

Press OK.

Type another code.

Press OK.

**OPER. SOFT. ISSUE**

**TESTER :     Y**  
**AUTOTRONIC : ?**

**PRESS CLUTCH PEDAL**

**TCU OFF**

**CODE**

**OLD : 022111010000**  
**NEW : \_**

**OK**   ◀   **ESC**

**CODE**

**OLD :022111010000**  
**NEW : 022112010000**

**OK**   ◀   **ESC**

**CODE**

**OLD : 022111010000**  
**ERR : 020112020000**  
**NEW : 032112.....**

0,9   **OK**   ◀   **ESC**



## Autotronic 2 - Parameters

11C04.3

### B. Key to parameters

B187036 = Tractor serial number

022111010000 = Parameter code

**AABCDEFGHIHXXX**

**Note : The three last digits are 000**

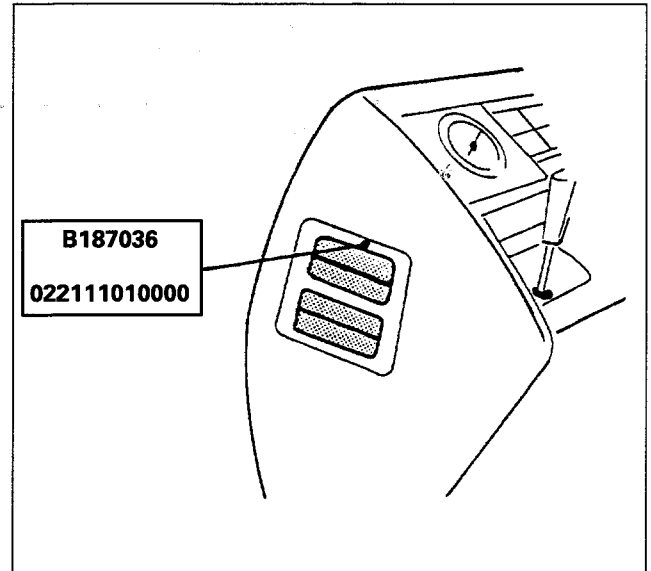

Parameter code	A	A	B	C	D	E	F	G	H	I	J	K
Parameter exemple	0	2	2	1	1	1	0	1	0	0	0	0

Code AA = 02 = MF 6150 with not modified flow hydraulic pump

Code B = 2 = with 4 WD

Code C = 1 = with Hare/Tortoise synchro

Code D = 1 = 4 x 2 gearbox (without A/B range)

Code E = 1 = speed limit 30 km/h

Code F = 0 = without Speedshift

Code G = 1 = Dynashift with control by lever

Code H = 0 = mechanical reverse shuttle

Code I = 0 = not used

Code J = 0 = not used

Code K = 0 = not used



11C04.4

## 6100 SERIES TRACTORS

**Autotronic 2 - Parameters**

Code AA : Tractor model

MODEL	CODE AA		6100 Closed centre
	Open centre Non modified flow hydraulic pump up to S/N D125026	Open centre Increased flow hydraulic pump from S/N D125027	
6110 - 6120 - 6130 - 6140	00	19	25
6150 - 6160 - 6170	02	20	26
6180	03	21	27
	<b>PTO 540 / 1000</b>	<b>PTO 750 / 1000</b>	
8110 - 8120 Normal Duty	05	12	
8110 - 8120 Heavy Duty	06	13	
8130 Normal Duty	07	14	
8130 Heavy Duty	08	15	
8140 - 8150	09	16	
8140 - 8150 Double reduction	10	17	
8160 Double reduction	11	18	
8160 Heavy Duty reinforced gearbox	23	24	

Code B Front axle	Code C Hare/Tortoise	Code D Gearbox type	Code E Speed limit
1 = 2 WD 2 = 4 WD 3 = 4 WD "with memory" from F167026 (c)	0 = Without synchronesh 1 = With synchronesh	1 = 4 x 2 (without AB) 2 = 4 x 4 (with AB) (a)	1 = 30 kph 2 = 40 kph 3 = 33 kph (Japan) 4 = 40 kph for Heavy Duty reinforced gerabox

Code F : Speedshift	Code G : Dynashift	Code H : Reverse shuttle
0 = without Speedshift 1 = Control button on gear lever 2 = Control by lever	0 = without Dynashift 1 = Control by lever 2 = Control by button on the gear lever	0 = Mechanical 1 = Hydro-electrical with pre- selected reverse by button (b) 2 = Hydro-electrival with pre- selected reverse by lever (b)

(a) for 3000/3100 series  
(b) for 6100 series only

(c) For all tractors with Autotronic 2 in M version



***Autotronic 2 - Reprogramming***

11C05.1

*11C05 Reprogramming the Autotronic 2*

CONTENTS

<b>A.</b>	<b>Programming on the tractor</b> _____	<b>2</b>
<b>B.</b>	<b>Programming off the tractor</b> _____	<b>4</b>





11C05.2

## 6100 SERIES TRACTORS



# Autotronic 2 - Reprogramming

### A. Programming on the tractor

This operation takes about 7 minutes and is not normally necessary, except for updating.

**Example:** Switching from issue Y-1 to Y.

Select PROGRAM.

If the ETCU program is at issue Y, no reprogramming is required.

If you wish to perform reprogramming, press OK. Otherwise press ESC.

Note: If the ETCU issue is more recent than that of the tester, a message is displayed on the screen informing you that the operating software is not compatible. Press ESC.

Contact Beauvais to update the tester.

Start the engine to provide an electric power supply of more than 13 V. If the voltage is lower than 13 V, an error message is displayed on the screen.

Disconnect the connector **F** to reset the program, press OK and then reconnect.

Press OK.

Press the clutch to reset the Autotronic electronic transmission control unit.

The program is loaded automatically.

The ETCU program is, first of all, erased (no indicator light on) for about 2 minutes.

The tester then reprograms the ETCU at issue Y (indicator lights **B** and **C** or Speedshift in Hi range are illuminated).

Wait for programming to be completed (about 5 minutes).

PROGRAM TCU

OPER. SOFT. ISSUE OK

PROGRAM  
NOT NECESSARY

CONFIRM PROGRAM?

OK

ESC

PROGRAM TCU

START ENGINE  
PRESS OK

DISCONNECT CONNECTOR F  
PRESS OK

RECONNECT CONNECTOR F  
PRESS OK

OK

ESC

PROGRAM TCU

PRESS CLUTCH PEDAL  
PRESS OK

WAIT

OK

ESC

PROGRAM TCU

WAIT PROGRAMMING

32766

OK

ESC



## 6100 SERIES TRACTORS



# Autotronic 2 - Reprogramming

11C05.3

The displayed value switches from 32766 to 0. Once reprogramming has been completed, the indicator lights **A, B, C** and **D** (or Speedshift Hi and Lo) come on. If a problem occurs during reprogramming, the tester indicates that problem and only indicator light **A** or **B** comes on.

Check the power supply and connectors.

Disconnect the ETCU and start again.

The program is now loaded in the ETCU.

Disconnect connector F of the ETCU to reset.

Press OK. Reconnect. Press OK.



**Do not forget to reconnect and then check the parameters (see Parameter).**

**PROGRAM TCU**  
**WAIT PROGRAMMING**  
**0**  
**PROGRAM OK**

**DISCONNECT CONNECTOR F**  
**PRESS OK**  
**CONNECT CONNECTOR F**  
**PRESS OK**

**OK** **ESC**

### Autotronic: Operating software issue

TRW TRANSPORTATION ELECTRONICS	<b>TRW</b>
TRW N°:	02100-00 Issue F
OP-SOFTWARE N°:	02795-00 Issue Y
BOOTROM SOFTWARE N°:	02912-00 Issue B
MASSEY FERGUSON N°:	3618318M05A
Serial N°:	9502 xxxx
Transmission Control Unit	
Tested: _____	
Made in UK	
CASE MUST BE EARTHED	

**OP-SOFTWARE** = TCU operating software

#### For information :

- Issue B : first configuration
- Issue C : same characteristics as Autotronic 1
- Issue D : speed limit on 3100 Speedshift is 30 kph
- Issue E : dialog with tester
- Issue F : electro-hydraulic reverse shuttle and Hilo synchro
- Issue G : modification of the reverse shuttle
- Issue H : security mode introduction
- Issue H : security mode modification

**BOOTROM SOFTWARE** = Software including non-reprogrammable read-only memory.

**Issue B only**



11C05.4

## 6100 SERIES TRACTORS

**Autotronic 2 - Reprogramming****B. Programming off the tractor**

It is also possible to load the operating software or change the Autotronic parameters without being connected to the tractor.

- Connect harness number 3712723M1 (Fig. 1) to connectors **A** and **F**. Connector **A** has four Dynashift indicator lights (A, B, C and D) and a clutch contactor earth connection, input line **A16**.
- Connect the tester to connector **E** and connect power supply **X1** to connector **X2** of harness 3712723M1.
- Connect power supply **Y1** to a generator **Y2: 12 volts - 1 A for parameter-setting; 13 volts minimum for programming).**  
Brown wire on red wire: + 12 volts  
Blue wire on black wire: Earth

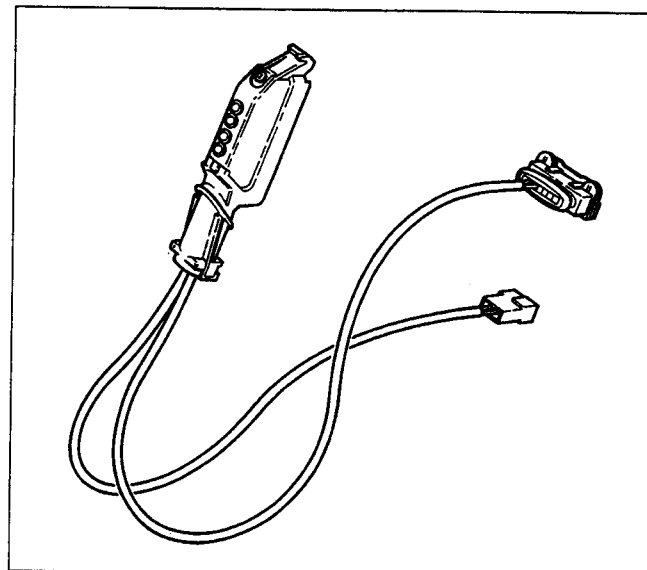

**Note: The electronic unit is now in alarm mode with a permanent earth for the clutch signal. There is, therefore, no need to press the clutch to activate the TCU.**

**The TCU modes are monitored by four indicator lights:**

- **no program = A, B, C, D lit up,**
- **incorrect parameter = flashing from AC to BC,**
- **during programming:**
  - erasing = indicator lights out**
  - loading = BC**
  - completed = A, B, C, D,**
  - error = A or B,**
- **normal alarm mode:**
  - D = Dynashift**
  - A or B = Speedshift**



# 6100 SERIES TRACTORS



## Autotronic 2 - Reprogramming

11C05.5

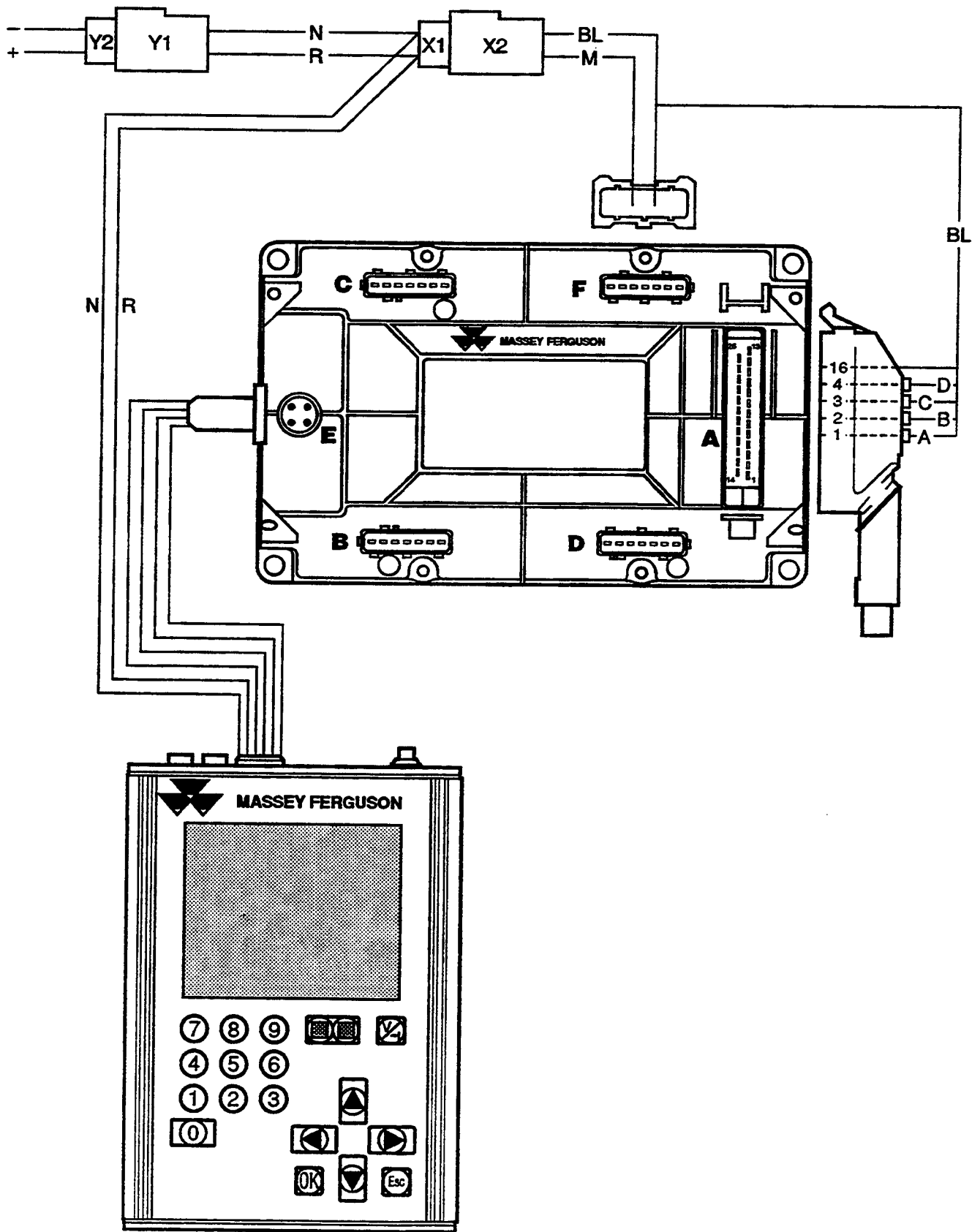





**Datatronic** - Description

11D01.1

*11D01 Description*

CONTENTS

<b>A. General</b>	_____	<b>2</b>
<b>B. Description of the screen</b>	_____	<b>2</b>
<b>C. Symbols</b>	_____	<b>3</b>
<b>D. Use of the tractor performance monitor</b>	_____	<b>4</b>
<b>E. Other functions</b>	_____	<b>8</b>



11D01.2

6100 SERIES TRACTORS



## Datatronic - Description

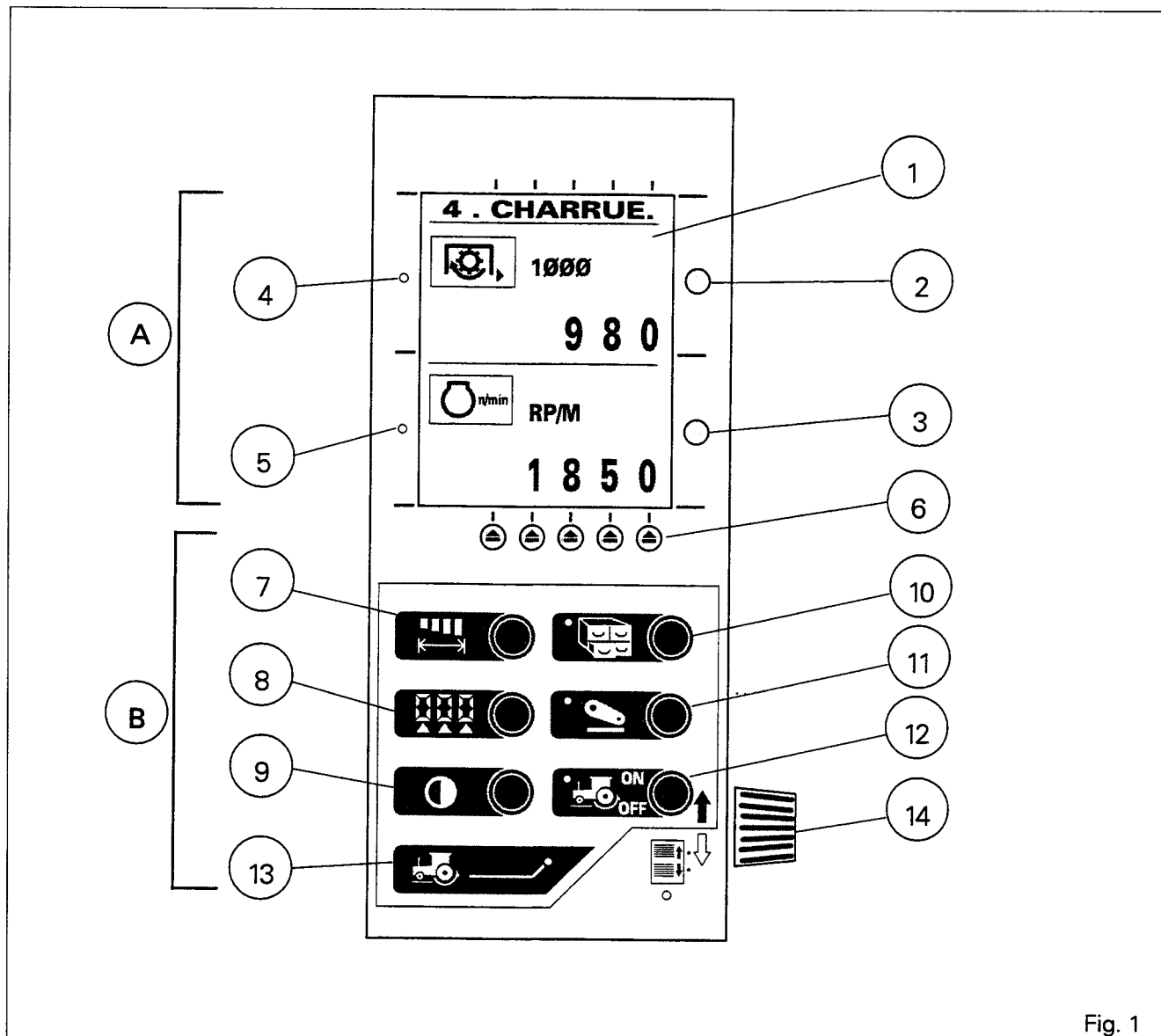

Fig. 1

### A . General

The tractor performance monitor computer is a measuring system providing information that helps to make optimum use of the tractor. The unit is fitted on the right-hand side pillar of the cab. This information is stored and can be printed directly from the cab (see "printing of the memory").

*Cet équipement offre les avantages suivants :*

1. Mise à la disposition du conducteur d'une grande quantité d'informations pour choisir les meilleurs réglages concernant le couple formé par le tracteur et son outil.
2. Mémorisation des informations et possibilité de les imprimer directement à partir d'une imprimante située dans la cabine (voir impression contenu mémoire).
3. Contrôle du patinage des roues pour amélioration du rendement, réduction de l'usure des pneus et limitation du compactage du sol.

### B . Description of the screen

#### Data display

- 1 - Screen divided into two parts.
- 2-3 - Selection keys for upper and lower display.
- 4-5 - Red led indicating the display selected.

#### Selection of functions

- 6 - Keys used to change stored data
- 7 - Working width
- 8 - Reset
- 9 - Screen contrast
- 10 - Memory on/off
- 11 - Working position
- 12 - Wheel slip control
- 13 - Slip control indicator
- 14 - Selection of the 22 functions of the menu or changing of the characters after selection of one of the keys 2 or 3.



## Datatronic - Description

### C. Symbols

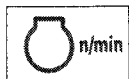

**Engine speed** : Instantaneous engine speed in RPM.



**PTO 540/1000 rpm** : PTO speed in rpm



**Forward speed** : This is the real forward speed of the tractor in relation to the ground in KPH.



**Wheel slip** : This is the real rate of wheel slip as a percentage.



**Wheel slip limit** : Maximum value accepted by operator or maximum limit. Over this limit, the wheel slip control's percentage varies unit by unit.



**Area per hour** : Area worked per hour.



**Fuel per hour** : Instantaneous consumption per hour (liter, gallon).



**Fuel per area** : Consumption per hectare or acre worked.

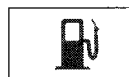

**Fuel used** : Total fuel used



**Area worked** : This is the total area in acres or hectare worked but only when the implement is working.



**Temperature** : Digital reading of the external temperature.

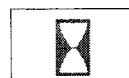

**Time spent** : The time accumulated when engine is running.

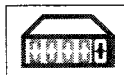

**Counter** : Can be used to count and memorize any unit desired (for example number of baces).

**Cost per hect** : In stantaneous cost per area unit worked (in local currency).



**Service** : Display the number of hours before the next service.



**Distance** : Total distance covered (meter, mile).

**Clock** : See additional functions section.

**Date** : See additional section.

**Local cost** : Information about the local fuel cost (must be stored).

**Cost per hect** : Cost per hectare is the sum of the fuel cost and the cost per hour multiplied by the work rate (hours per hectare). Must be stored.

**Units** : Must be selected from:

- Metric : liters, meters, kilometers, hectares, degrees celsius,
- USA : US gallons, yards, miles, acres, degrees fahrenheit,
- UK : Imperial gallons, yards, miles, acres, degrees fahrenheit.





11D01.4

6100 SERIES TRACTORS



**Datatronic - Description**

**D . Use of the screen**

**Active mode**

**Active mode**

When the starter switch key is in ON position, the last data stored appears (fig. 2).

1 - Press the key 2 or 3 to access the available functions (fig. 3).

2 - Turn the knob 14 to select the function wanted.

3 - Press key 2 or 3 again to display the selection on the lower or upper part of the screen: e.g.:

Upper display : PTO speed

Lower display : Engine speed, 2 different functions can be displayed at the same time.

**Note:** If the units of data displayed (french franc, US dollar, pound) do not correspond, return to the menu, select **UNITS** and press key 2 or 3.

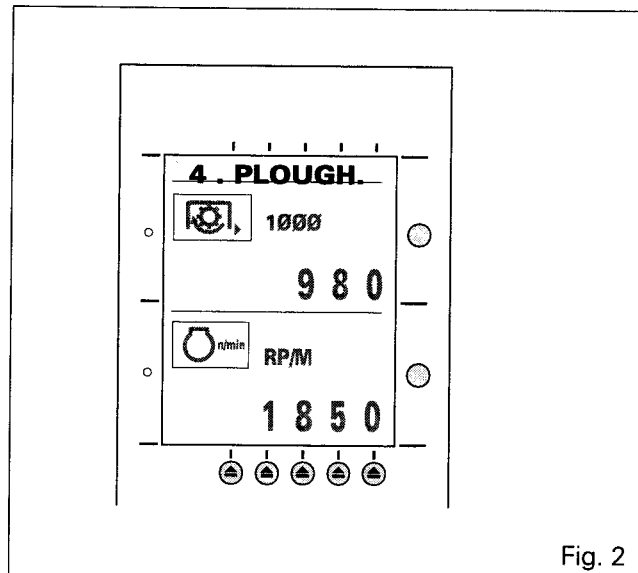
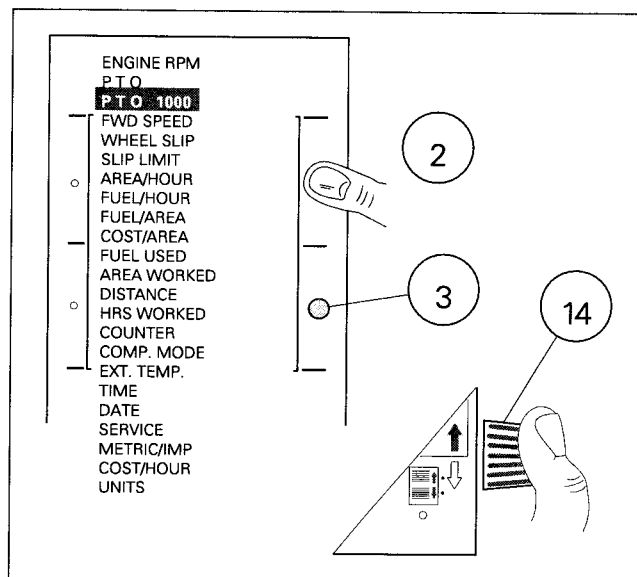

Fig. 2



**MEMORY MODE (fig. 4)**

The Datatronic features 4 independent memories identified by a number (1 to 4) and a name which can be introduced by the operator. It is possible to record the total work done with 4 different implements or to record the work done by four different drivers "1 SEEDER".

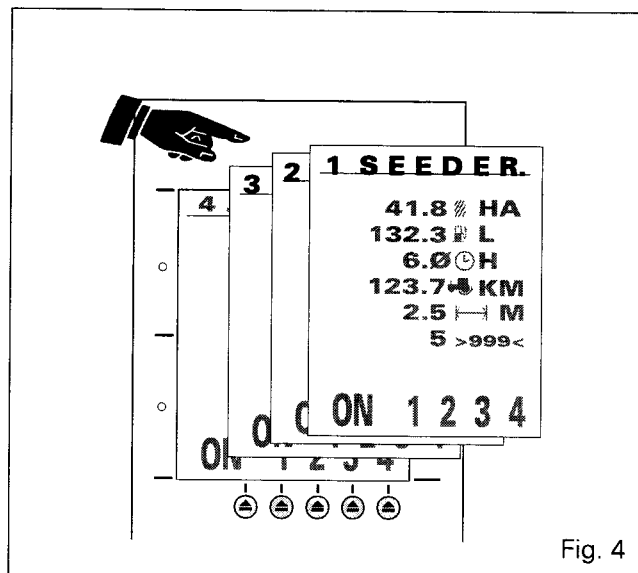
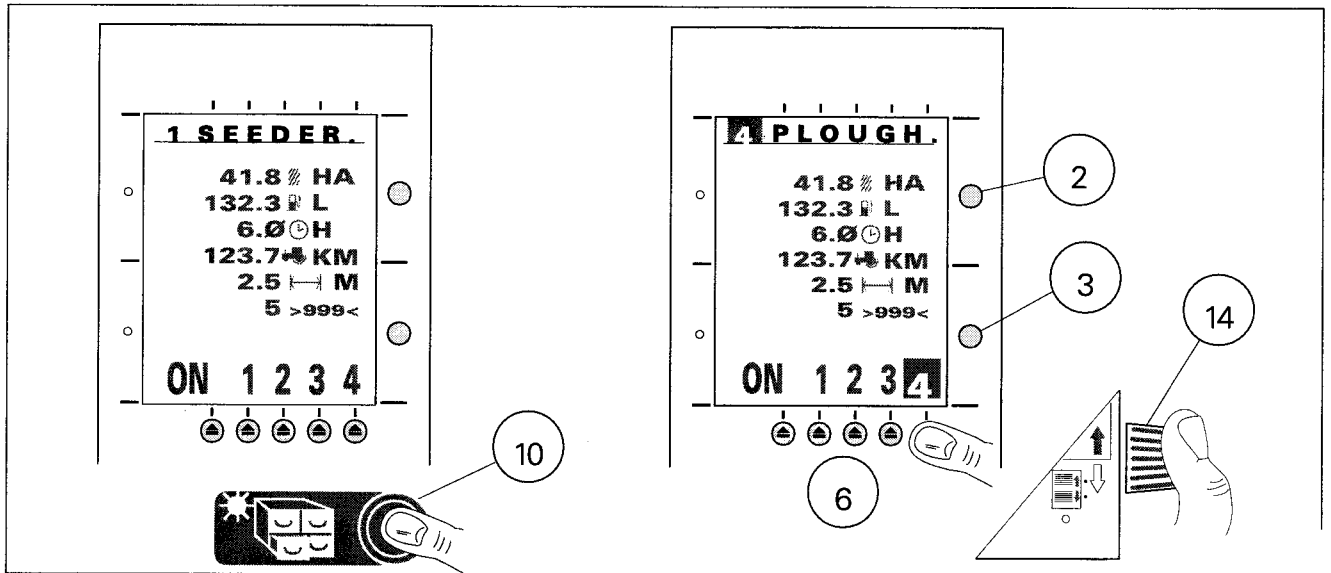

Fig. 4



## Datatronic - Description

11D01.5



### Use of the memory (fig. 5 - 6)

Select the memory mode by pressing the key 10.

To change the name of this memory, press the upper selection key 2, the first character of the screen becomes dark, e.g. **2**plough.

Turn the knob 14 to obtain the correct figure press key 2 again, to validate the first character and select the second one.

Same method for the second, third characters.

To move the selection from right to left, press key 3.

To reset the area selected, press one of the key 6.

To reset the stored value other than the test display, press key 8.

**ON/OFF Position:** If you do not want to record the next work, press key C to go to the "OFF" position, the top of the screen displays "MEMORY OFF". To return automatically to the "ON" position, press the memory key 10.

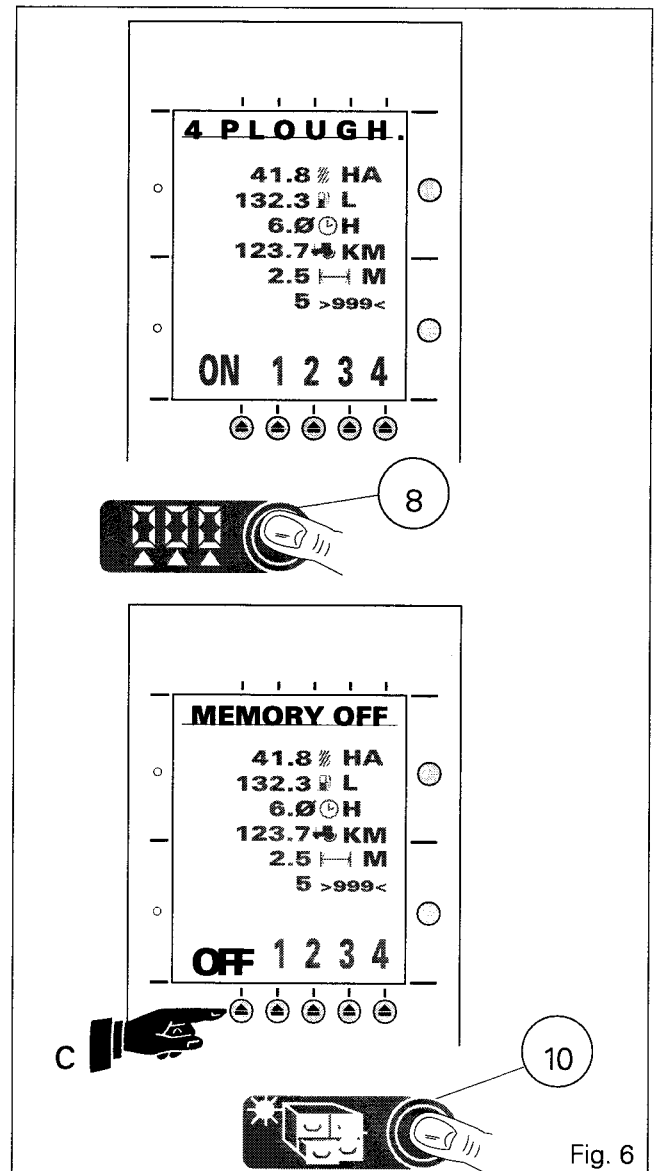

Fig. 6



11D01.6

6100 SERIES TRACTORS



## Datatronic - Description

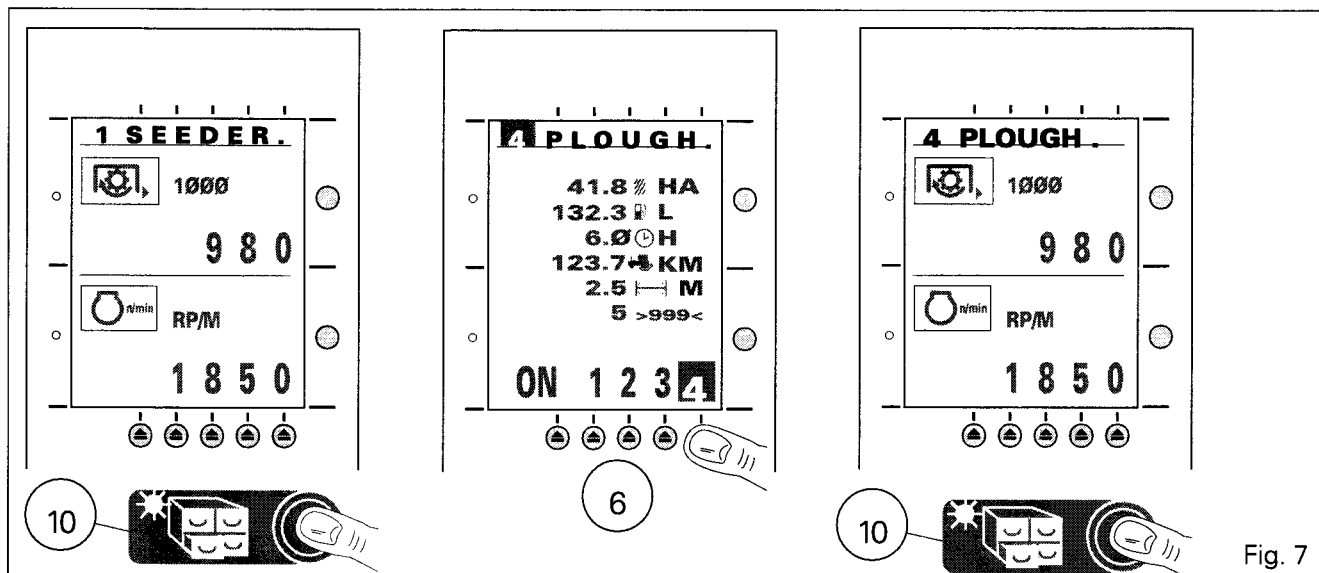

Fig. 7

### Use when working

Before starting your work, select the memory that you want (1 to 4); refer to the "MEMORY MODE" section, page 4.

Press the memory key 10 (fig. 7), then press the key 6 corresponding to the memory that you want to use for your work; *the selection appears in grey*.

Press key 10 again: the pre-recorded data (name, implement, etc.) is displayed at the top of the screen. The half-screens display the last selections stored when quitting, before selecting "MEMORY MODE".

### Working position

This operating mode takes three parameters into account:

1. The PTO speed in ON/OFF position,
2. The elevation (low position) ON/OFF,
3. The coupled implement (through the auxiliary socket located in the cab).

Application:

Select the working width of the implement used by pressing key 7 (fig. 8); modify the figures by pressing the corresponding keys 6, then turn knob 14 to display new values. Press key 7 again to return to the previous screen.

**Note:** *The display of the work function has priority whenever the key is pressed.*

Select the work function 11. The display appears, the work can start.

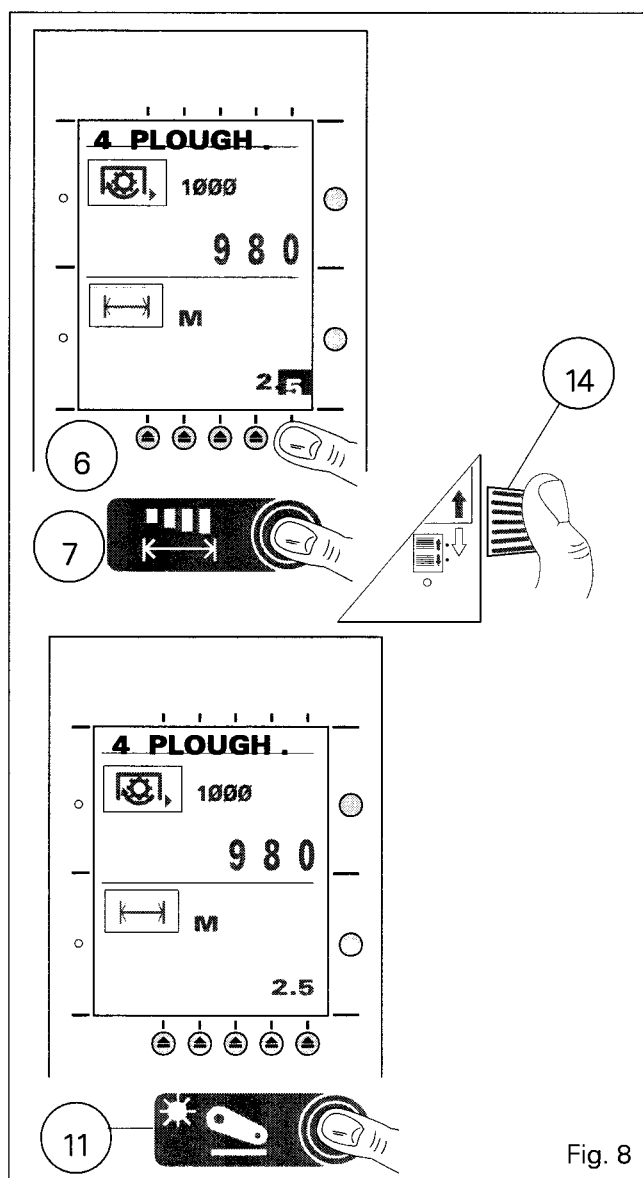

Fig. 8



## Datatronic - Description

11D01.7

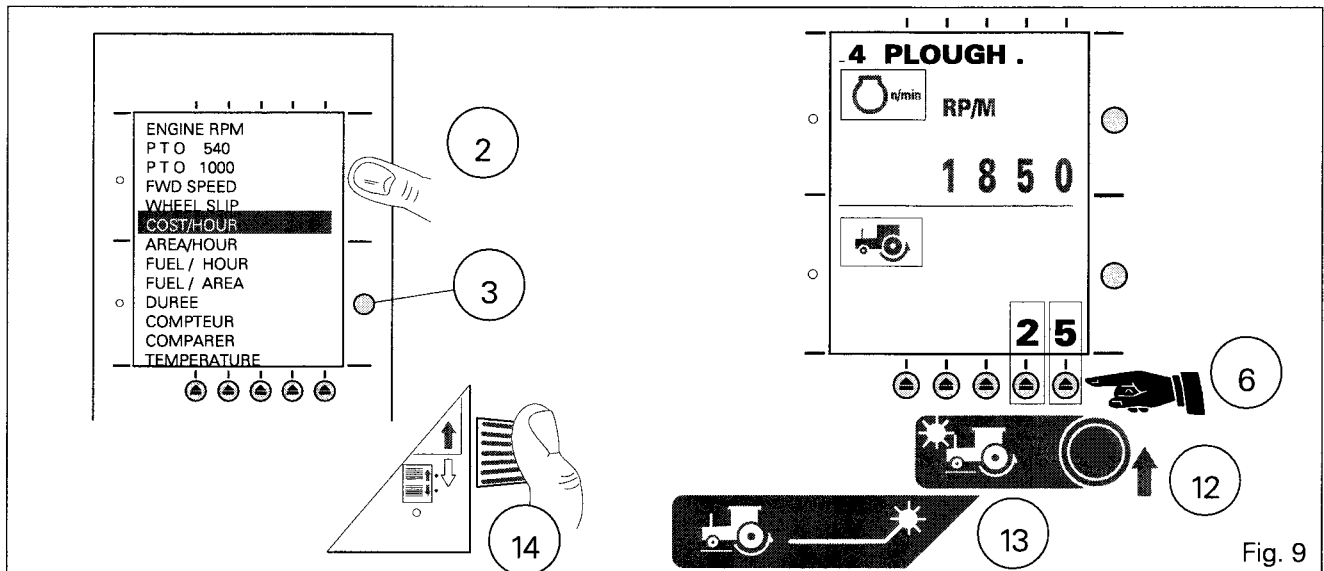

Fig. 9

### Wheel slip control (fig.9)

Setting the maximum slip limit

Select **SLIP LIMIT** in the function menu. Press keys 6 to enter the value.

When the wheelslip control 12 is on, the system continuously compares the real wheelslip rate with the limit set by the driver.

As long as the wheelslip is less than the set limit everything happens normally. When the rate becomes greater than the pre-set threshold, the system raises the implement during the time necessary to return to a normal situation complying with the set limit, and the control on LED flashes. The system reacts in the same manner when the driver changes the height/depth setting on the elevation panel.

### Comparative mode (fig. 10)

Select **COMPARE** in the function menu: a second menu appears.

Turn the knob 14 to select, for example, the **ENGINE RPM** line, and press key 2 or 3. The Datatronic displays the same function on both half-screens. The upper part displays the stored data, the lower part displays the real working data, and the LED flashes.

When the required working conditions are entered, press the memory key 10; the new data is stored in the upper window.

You can store other data (engine speed, forward speed, etc.) by carrying out the same operations.

The value is stored in memory until a new value is recorded.

To quit the comparative mode, press key 2 or 3 to return to the menu.

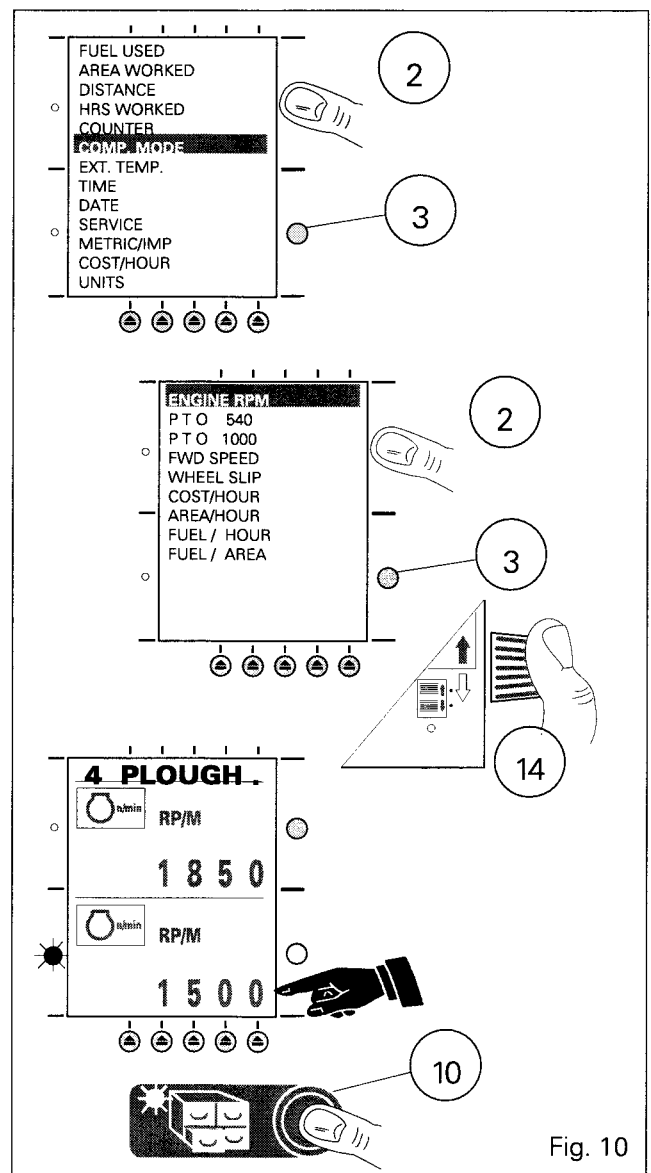

Fig. 10



11D01.8

# Datatronic - Description

Select **END** by turning knob 14 (fig. 11). Press 2 or 3 again, the active mode data is displayed.

## E . Other functions

### Auxiliary functions

Clock setting (hours, minutes, seconds) (fig. 13):  
 Press key 2 or 3: the list of functions is displayed.  
 Select **TIME** then press 2 or 3 again; the display appears in the selected window and LED 4 or 5 is lit.  
 Press one of the keys 6 corresponding to the figures to modify, then turn the knob 14 to modify these figures one by one.  
 Proceed in the same way to update the parameters Date, Month and Year.

### Screen contrast (fig. 13)

You can modify the screen contrast at any time by proceeding as follows:  
 Press key 9 until both LEDs 4 and 5 come on; turn knob 14 to lighten or darken the screen.  
 Press key 9 again or any other key to return to normal operation.

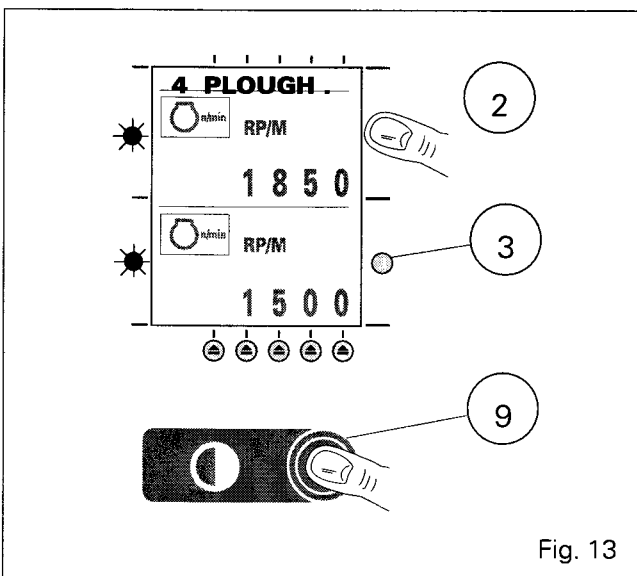
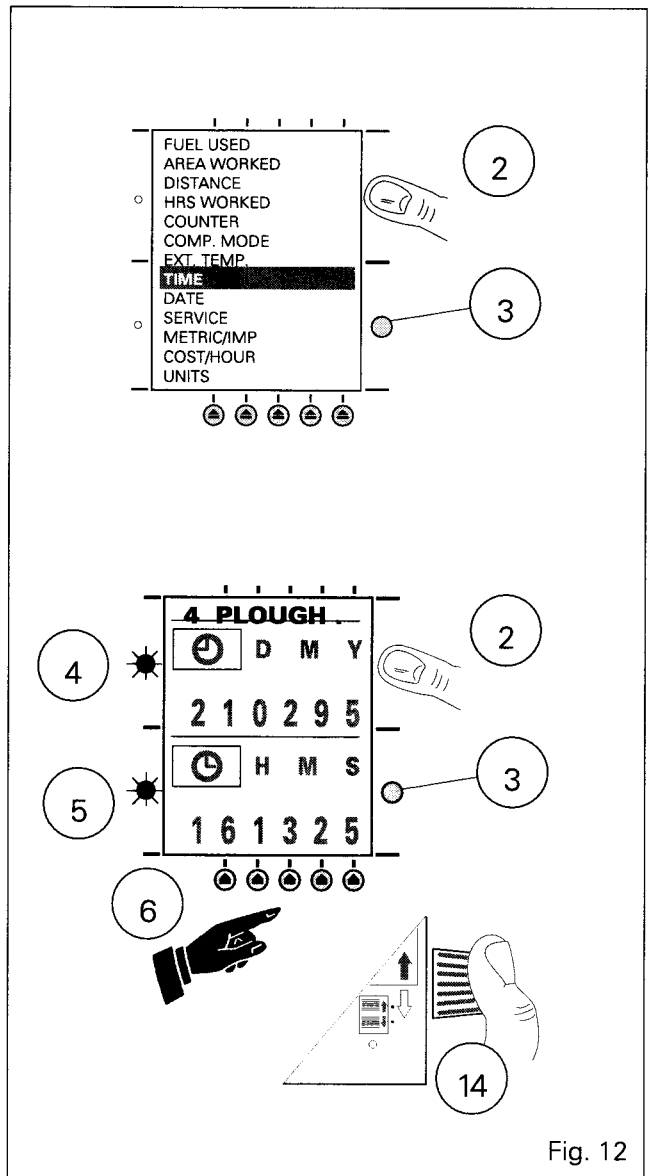
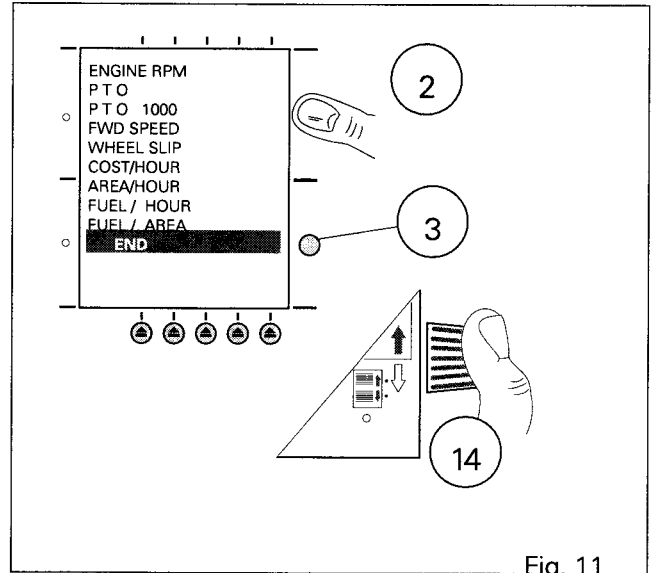



## Datatronic - Description

### Printing of the memory content (Fig. 14 - 15)

Select a HEWLETT PACKARD 82240 B compatible printer.

Fit the printer holder supplied as a kit (available from your dealer).

Remove the plastic cover under the Datatronic and install the printer, so that the infra-red readers are facing each other. Select the stored data by pressing the memory key 10, then press twice the key 6 corresponding to the memory that you want to print. The screen gradually colors; the LEDs (5 and memory 10) flash during the operation.

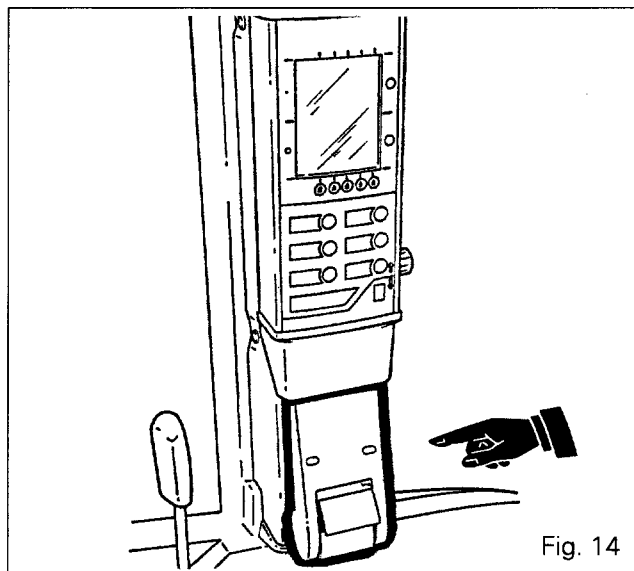

Fig. 14

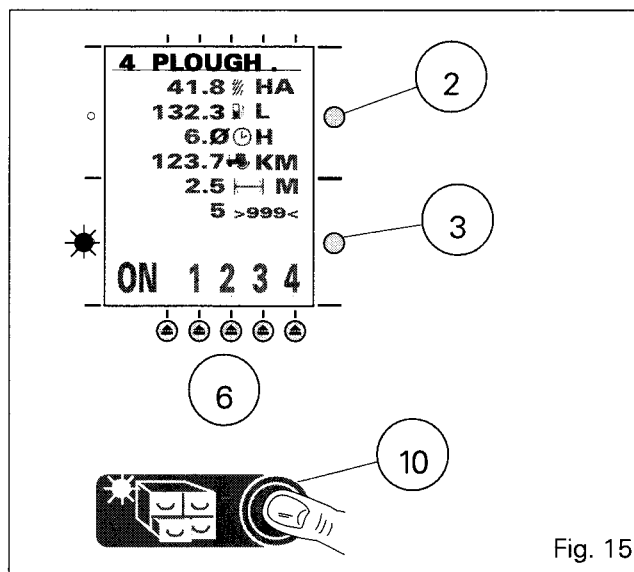

Fig. 15









**Datatronic** - Using the tester

11D02.1

*11 D02 Using the tester*

## SOMMAIRE

<b>A. General</b>	_____	<b>2</b>
<b>B. Symbols (icons)</b>	_____	<b>2</b>
<b>C. Connections</b>	_____	<b>2</b>
<b>D. Functions</b>	_____	<b>3</b>
<b>E. Operating procedure</b>	_____	<b>4</b>



11D02.2

# 6100 SERIES TRACTORS



## Datatronic - Using the tester

### A . General

As in the case of the Autotronic unit, the Datatronic must be configured according to the specifications of the tractor it is installed on.

The tester can be used to check the various values calculated by the Datatronic system and, also, to display the menu in the tester language.

### C . Connections

Use connection No. 4 (section 11 A01). If harness 3714780M1 is not available, use the connection shown in Fig. 1.

### B . Symbols (icons)

The specific Datatronic functions or components are identified by the following symbols:

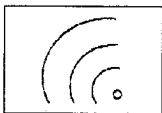

Radar

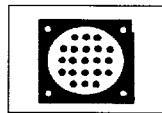

Connector



Flowmeter



Flowmeter

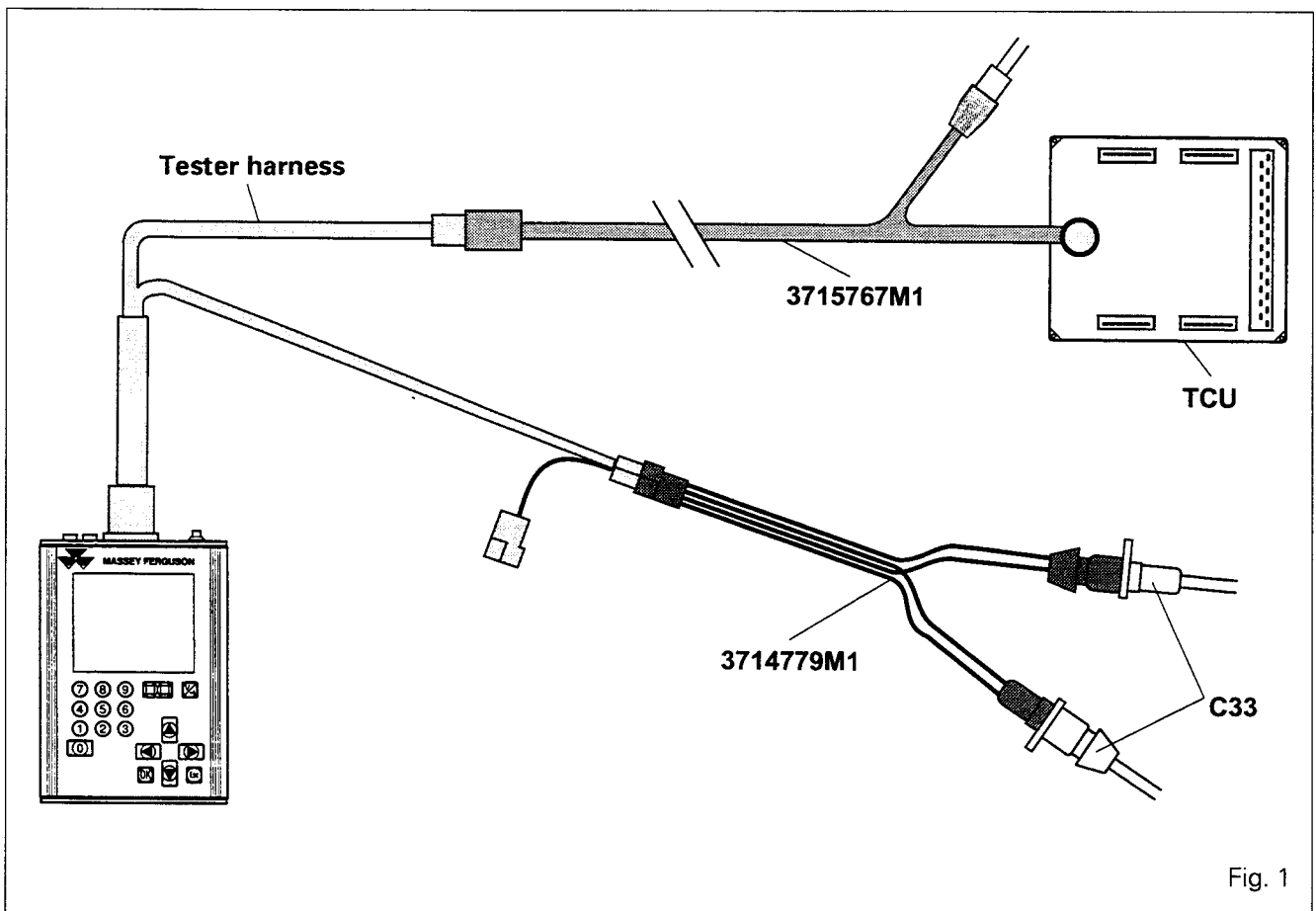

Fig. 1



## **Datatronic** - Using the tester

### **D . Functions**

#### **Parameter**

In order to supply correct data, the Datatronic unit must be parameterised with all the specifications of the tractor it is installed on.

The parameters (three-figure codes) can only be transmitted via the tester.

#### **Frequencies**

With the Datatronic option, a «communication link» can be established between an implement and the tractor by means of the 16-way connector located in the cab. As the applications are variable and numerous, a wide signal range is provided for on this connector's output:

- Engine frequency
- Radar frequency
- PTO frequency
- Forward speed sensor frequency (theoretical speed)

These signals are generated by two outputs on the Datatronic unit:

- Pin 1 (connection No. 1): Engine frequency or Radar frequency
- PPin 2 (connection No. 2): PTO frequency or Forward speed sensor frequency.

The tester allows the two outputs, Pin 1 and Pin 2, to be configured by selecting the desired frequencies and adjusting the value of the signals according to the requirements of the implement.

#### **Test**

This allows the values calculated by the Datatronic to be checked for the actual speed and instantaneous fuel consumption. For this purpose, the values of radar and theoretical forward speeds and the outward and return fuel flow rates.

#### **Translation**

This allows the menu on the tractor computer to be displayed in the tester language.



11D02.4

## 6100 SERIES TRACTORS

**Datatronic** - Using the tester**E . Operating procedure**

Switch on for connection No. 4.

For the connection with harnesses 3714779M1 and 33715767M1, power supply is direct.

This screen allows the selection of the circuit to be tested. Use the cursor arrow keys to position the grey bar on Datatronic.

Press OK.

**AUTOTRONIC**

---

**DATATRONIC**

---

**ELECTRONIC LINKAGE**

**OK**
▲
▼

The tester indicates the operating software issues stored in the tester and the Datatronic unit.

Press OK.

**OPER. SOFT. ISSUE**

**TESTER**           :   **D950700**  
**DATATRONIC**     :   **D950202**

**OK**
**ESC**

**Parameter**

The tester offers the following choice: parameter, test, translation.

Select «Parameter».

Press OK.

---

**PARAMETER**

---

**TEST**

**TRANSLATION**

**OK**
▲
▼
**ESC**



## Datatronic - Using the tester

11D02.5

This screen is used to select either parameterisation or output frequencies.  
Select «Parameter».  
Press OK.

PARAMETER			
OUTPUT FREQUENCIES			
OK	▲	▼	ESC

The tester reads the code installed in the Datatronic unit and displays «OLD».  
Enter the three-figure code of the tractor the Datatronic unit is installed on.  
The code is displayed opposite the word «NEW».  
See the parameterisation table.  
Press OK.

CODE			
OLD	:	210	
NEW	:	_	
0 - 9	OK	◀	ESC

When the code has been entered, the tester checks its structure.  
If the code is not correct, the tester displays an error message (see Section 11 A01).  
If the structure is correct, the tester asks for confirmation of the code and the message «Code correct» is displayed.  
Press OK.

CODE			
OLD	:	210	
NEW	:	210	
CODE CORRECT			
0 - 9	OK	◀	ESC

The function selection screen is redisplayed.

PARAMETER			
TEST			
TRANSLATION			
OK	▲	▼	ESC

Switch off and then switch on again to validate and return to the first menu (reboot).



11D02.6

## 6100 SERIES TRACTORS

**Datatronic** - Using the tester**Parameter coding**

The parameter code is made up of three figures. The first two figures indicate the tractor model and are identical to those for Autotronic II parameters. The latter can easily be identified by means of the label bonded onto the fuse box. The list of parameters corresponding to the tractor model (code AA) is also included in section 11 C04. **Take care to check the serial number.**

The third figure corresponds to the Dual Control option which is now managed by Datatronic, so it is necessary to specify whether this option is installed or not.

If the Dual Control option is installed, enter 1.

If the Dual Control option is not installed, enter 0.

For information, the table below specifies the programmed values for a rated engine speed of 2,200 rpm.

Code	Nbr signals / engine rev.	Nbr signals / 10 km/h	Radar signals / 10 km/h	PTO 540/750 rpm	PTO 1,000 rpm	Outward fuel	Return fuel
00	73	108	273	103	56	1	1
01	73	111	273				
02	73	106	273	103	56	1	1
03	73	115	273	103	56	1	1
04	73	114	273	103	56	1	1
05	89	125	273	107	61	1	1
06	89	142	273	107	61	1	1
07	89	125	273	107	61	1	1
08	89	138	273	107	61	1	1
09	89	136	273	107	61	5	5
10	89	146	273	107	61	5	5
11	89	146	273	107	61	5	5
12	89	125	273	99	78	1	1
13	89	142	273	99	78	1	1
14	89	125	273	99	78	1	1
15	89	138	273	99	78	1	1
16	89	136	273	99	78	5	5
17	89	146	273	99	78	5	5
18	89	146	273	99	78	5	5
19	77	108	273	103	56	1	1
20	77	106	273	103	56	1	1
21	77	115	273	103	56	1	1
22	77	114	273	103	56	1	1
23	89	146	273	107	61	5	5
24	89	146	273	99	78	5	5



## Datatronic - Using the tester

11D02.7

### Output frequencies

Use the keyboard to return to the «Parameter screen».

This screen is used to select either parameterisation or output frequencies.

Choose «Parameter».

Press OK.

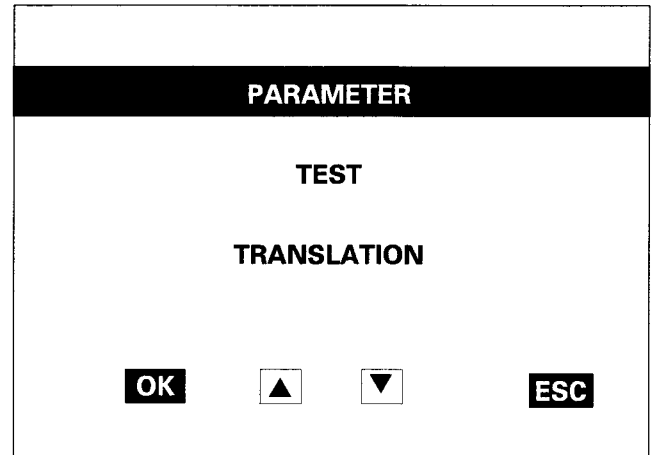

This screen is used to select either parameterisation or output frequencies.

Choose «Output frequencies».

Press OK.

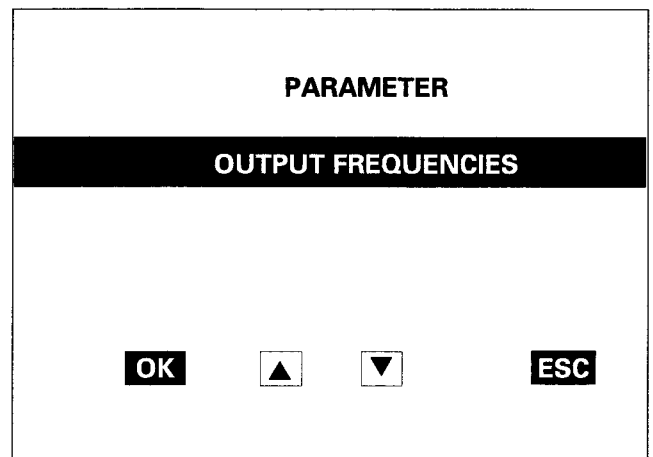

- 1 - PTO frequency
- 2 - Theoretical forward speed frequency
- 3 - Engine frequency
- 4 - Radar frequency

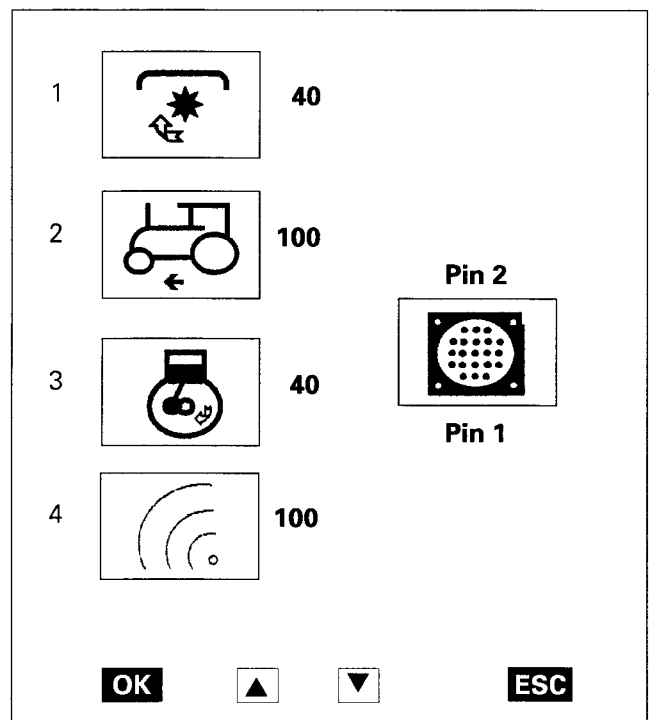







11D02.8

6100 SERIES TRACTORS



## Datatronic - Using the tester

### Using the keys

  To move the arrow opposite one of the four icons.

**OK** To validate the selection of an icon. The selection is defined by the position of the arrow. When validated with the OK key, the icon indicated by the position of the arrow changes state and the value displayed opposite it is cleared. The tester is then ready to receive new data.

### Modifying the value of frequencies

The figure indicated opposite each icon actually corresponds to a multiplying coefficient used by the Datatronic unit to generate an output frequency on the basis of a reference frequency originating from a tractor component.

#### For engine speed and PTO frequencies:

$$F = \frac{N}{60} \times Y$$

F = frequency (Hz)

N = rpm

Y = Hz/rpm = revolution coefficient.

Coefficient **Y** for revolution speed must be between 40 and 60.

#### For radar and forward speed frequencies:

$$F = \frac{V}{10} \times Z$$

F = frequency (Hz)

V = km/h

Z = Hz/km.h = linear coefficient

Coefficient **Z** for linear speed must be between 100 and 400.

**Example:** If a PTO speed is selected with a revolution coefficient **Y** of 40, an output frequency of 400 Hz is obtained for a speed of 600 rpm.

$$F = \frac{600 \text{ rpm}}{60} \times 40 = 400 \text{ Hz}$$

### Caution:

**If one of the frequencies has been selected but the specified value of the coefficient is not correct, the  icon is displayed to indicate that the value cannot be accepted.**

Clear the incorrect value by pressing OK.

Enter the correct value and press OK.

To quit: press ESC.



## Datatronic - Using the tester

11D02.9

### Monitoring the calculated values

The tester offers the following choice: parameterisation, test or translation.

Select «Test».

Press OK.

1. Radar frequency
2. Theoretical forward speed frequency
3. Flowmeter frequency: input flow rate
4. Flowmeter frequency: return flow rate
  - a. Pin No. on 29-way connector
  - b. Speed displayed on tractor computer
  - c. Fuel consumption per hour displayed on the tractor computer

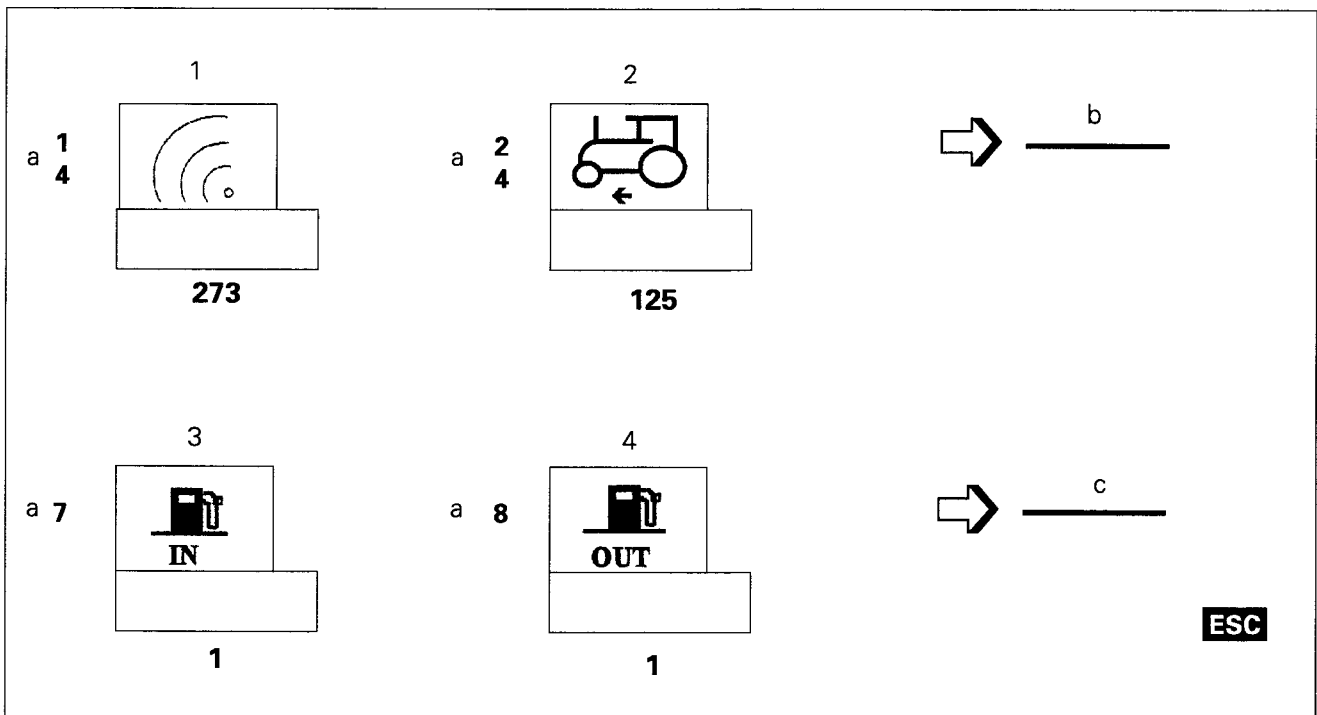
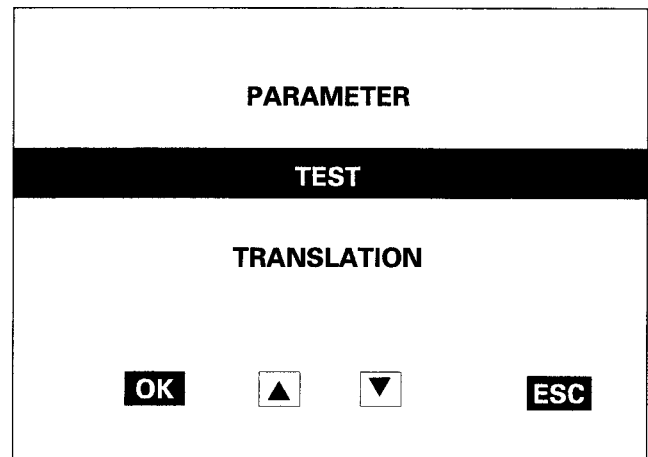

### Display

When the tractor is travelling at less than 1 km/h, the actual speed is zero (radar precision) and only the theoretical speed is displayed.

When the tractor is travelling at more than 1 km/h, the actual speed is displayed with allowance for effective wheel slip.

If both speeds are greater than 20 km/h and there is a difference of 10% between them, it is the theoretical speed that is displayed directly (incorrect wheel diameter or driving in puddle).

The display of flow rates varies according to the effective consumption of the engine (position of accelerator, load applied, etc.). Display **c** on the extreme right-hand side is equal to the difference between the input and the output.

This must remain true in all cases. Otherwise, it means that there is a problem either on the flowmeter (internal fouling, fault on electrical connections) or the parameterisation is wrong.



11D02.10

# 6100 SERIES TRACTORS



## **Datatronic** - Using the tester

### Translation

The tester offers the following choice: parameterisation, test or translation.

Select «translation».

Press OK.

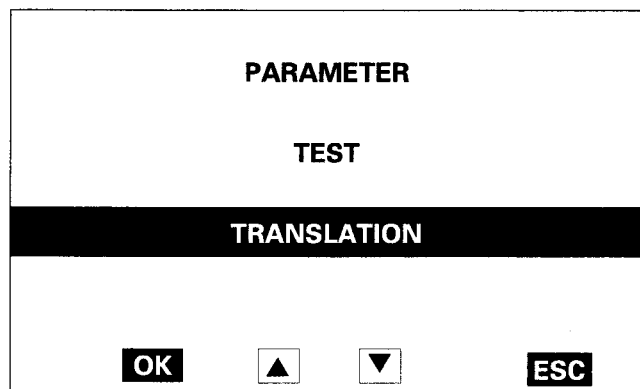

The translation of the whole text displayed on the Datatronic screen is being transferred from the tester to the Datatronic unit.

The language used is the same as that used by the tester.

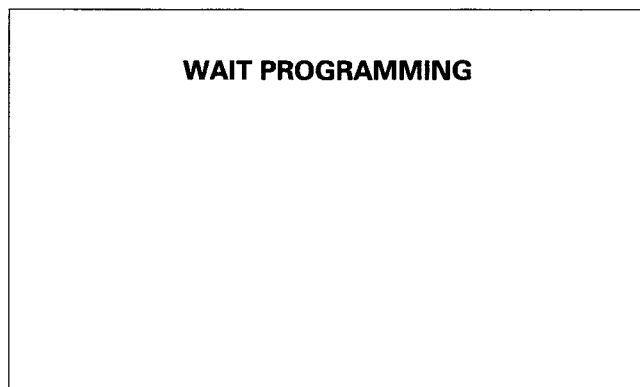

The transfer has been completed.

Automatic return to the function selection screen.

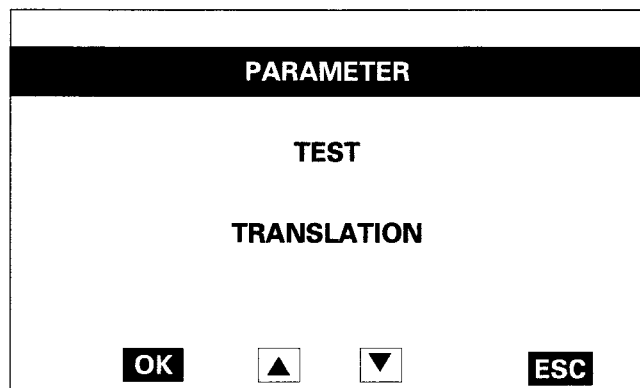

Switch off in order to validate the transfer.



# **12 . CAB**

## **Contents**

**12 A01 INSTRUMENT PANEL**

**12 B01 AIR CONDITIONING**

**12 C01 RECHARGING THE SYSTEM WITH REFRIGERANT**

**12 D01 AIR CONDITIONING SYSTEM FAULTS - COMPRESSOR**





*12 A01 Instrument panel*

CONTENTS

<b>A.</b>	<b>Description</b> _____	<b>3</b>
<b>B.</b>	<b>Warning light panel</b> _____	<b>4</b>
<b>C.</b>	<b>Digital display of PTO speed and forward speed (option)</b> _____	<b>5</b>



12A01.2

# 6100 SERIES TRACTORS



## Cab - Instrument panel

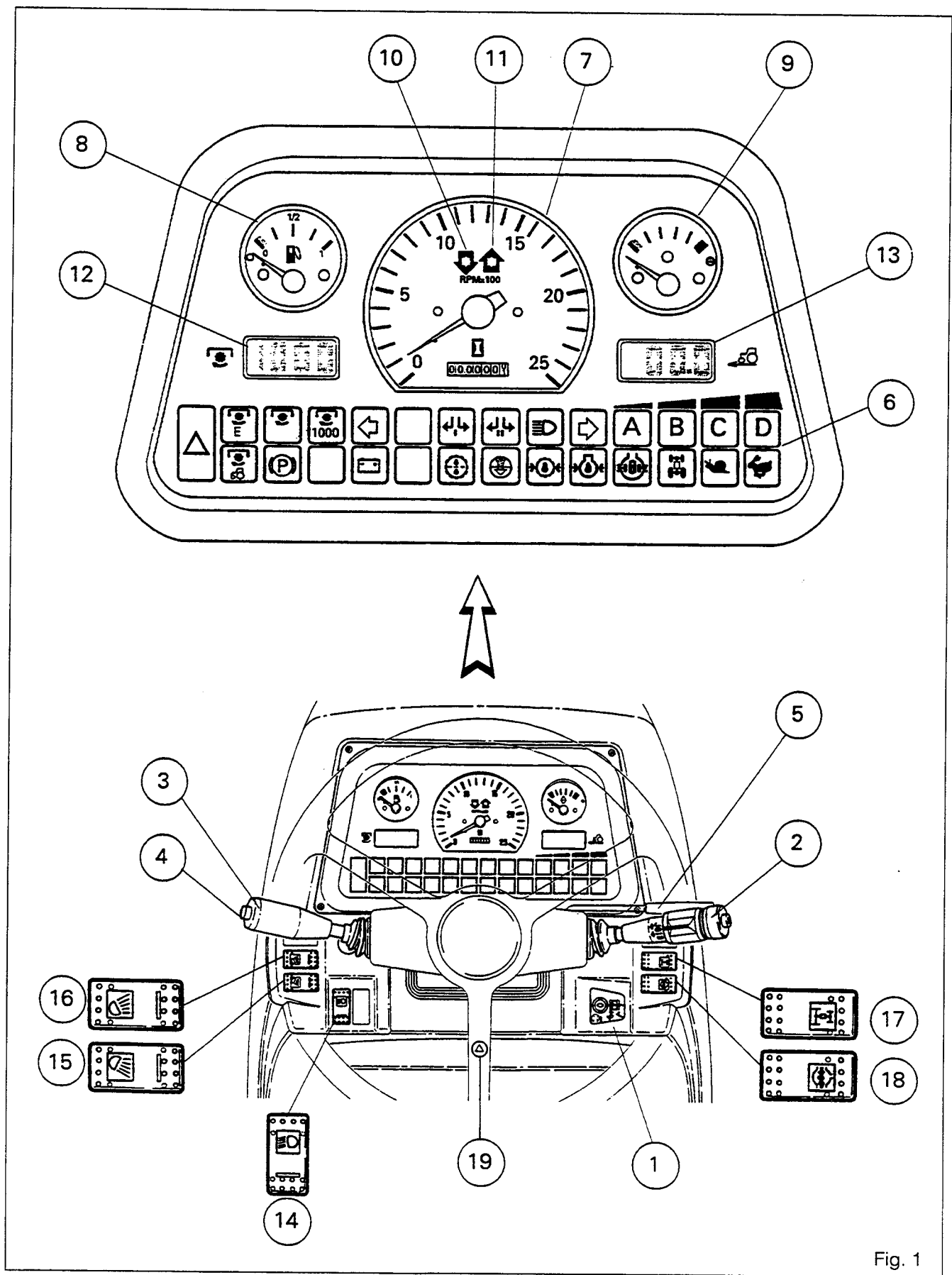

Fig. 1



## **Cab** - Instrument panel

### **A . Description (Fig. 1)**

#### **1. Starter switch - 4 positions**

- 1 - Stop
- 2 - On normal position for running the engine, but which also allows for the electrical equipment to be used when the engine is not running.
- 3 - Heat
- 4 - Start

#### **2. Direction indicator, light, horn, wiper and washer switch**

#### **3. Dynashift or Speedshift control lever**

#### **4. Electro-hydraulic reverse shuttle (option)**

#### **5. Steering wheel adjustment**

#### **6. Warning lights panel (see detail Fig. 2)**

All the warning lights are coming on during a few seconds when the ignition is put on. This allows to check they all work correctly.

#### **7. Tachometer/hourmeter**

The tachometer shows the engine speed in hundreds of revolutions per minute. The hourmeter shows the total number of working hours.

#### **8. Fuel gauge**

#### **9. Temperature Gauge**

The green zone shows the limits for the normal operating temperature. Stop the engine if the needle moves into the red zone.

#### **10. Electro-hydraulic reverse shuttle reverse warning light (option)**

#### **11. Electro-hydraulic reverse shuttle forward warning light (option)**

#### **12. Digital display of PTO speed (option)**

#### **13. Digital display of forward speed (option)**

#### **14. Side rear lights and dipped beam switch**

#### **15. Rear work lamps switch (after switching on side lights)**

#### **16. Front work lamps switch (after switching on side lights)**

#### **17. Four-wheel-drive control switch**

#### **18. Differential lock control switch**

#### **19. Hazard warning light control button**





12A01.4

## Cab - Instrument panel

### B . Warning lights panel (Fig. 2)

#### 1. Failure warning light (red)

This light comes on at the same time as the (red) warning lights. If it comes on, stop the tractor immediately and look for the causes of the failure.

#### 2. G.S.P.T.O warning light (yellow) (if fitted)

#### 3. Handbrake warning light (red)

#### 4. Not used

#### 5. Alternator charge warning light (red)

This charge warning light comes on when the starter switch key is in the "On" position but with the engine not started. The light should extinguish when the engine starts and the starter switch key is returned to the "On" position. If the warning light comes on when the engine is running, identify the cause of the failure (see section 10 A01).

#### 6. Not used

#### 7. Transmission oil filter warning light (red).

If this warning light stays on at normal operating temperature, immediately change the filter element. If the light continues to illuminate, identify the cause of the failure :

- Hydraulic (see section 9)
- Electric (see section 10 A01)

#### 8. Air cleaner warning light (red).

#### 9. Transmission oil low pressure warning light (red).

If this warning light illuminates during operation, identify the cause of the failure :

- Hydraulic (see section 9)
- Electric (see section 10 A01)

#### 10. Engine oil pressure warning light (red)

This warning light illuminates when the key is in the "On" position, but it should extinguish when the engine starts. If the warning light stays on when the engine is running, investigate the reason for the loss of pressure.

#### 11. Differential lock warning light (yellow)

#### 12. Four-Wheel-Drive engaged warning light (green)

#### 13. Creeper warning light (green) (if fitted)

#### 14. Hare warning light (green)

#### 15. Ratio speed warning light (green) (according to version) :

- Dynashift : A to D.
- Speedshift : C and D only

#### 16. Tractor direction indicator warning light (green)

#### 17. Main beam warning light (blue)

#### 18. Direction indicator warning light for the second trailer (green)

#### 19. Direction indicator warning light for the first trailer (green)

#### 20. Not used

#### 21. 1000 RPM P.T.O warning light (yellow).

#### 22. 540 RPM P.T.O warning light (yellow).

#### 23. Economy P.T.O warning light (yellow) (if fitted).

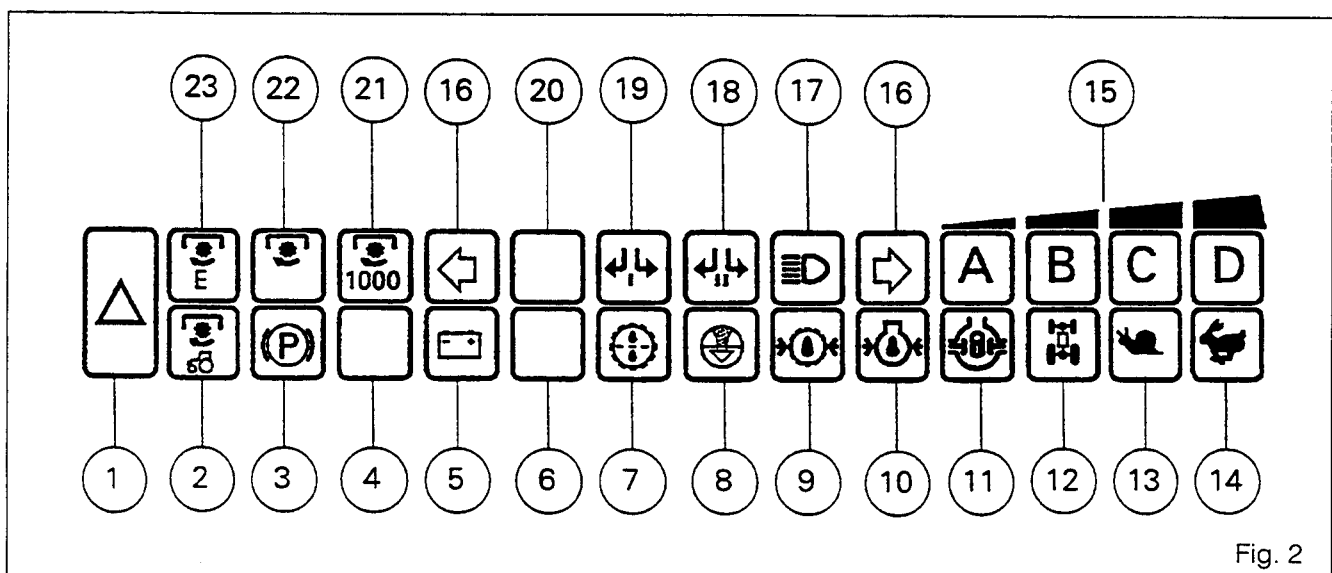

Fig. 2



## Cab - Instrument panel

12A01.5

### C . Digital display of PTO speed and forward speed (option)

The digital display depends on the programming of the dashboard electronic calculator.

#### 1. PTO speed

The digital display shows the speed of the PTO selected (540 or 1000 RPM) measured by the PTO sensor when the small in-cab switch (Fig. 3) is on the position related to the PTO used and when the corresponding warning light is on.

The calculator is programmed to the tractor PTO specifications

#### 2. Forward speed

The digital display shows the travel speed measured by the forward speed sensor or the speed measured by the radar (when fitted).

The calculator is programmed according to the average rolling circumference of the wheels per model for a standard tyre combination.

#### 3. Programming

The calculator is programmed by means of eight micro-switches numbered from 1 to 8 and located on the electronic card inside the dashboard, they are accessible from the back of the dashboard (Fig. 4).

The micro-switches can be :

- open (off = 0 (number way))
- closed to earth (on = 1)

The micro-switches No 1 to 5 correspond to the model and are used for the forward speed programming (see chart § 5, column (1)).

**Note : When the tyre combination is not standard, it is possible to modify the standard programming to reduce the margin between the theoretical travel speed shown and the real travel speed (see § 4 and 5).**

The micro-switches No 6 and 7 correspond to the PTO : 00 = PTO for all 6100.

The micro-switch No 8 correspond to the choice between miles or kilometers :

- 0 = Mph
- 1 = Kph

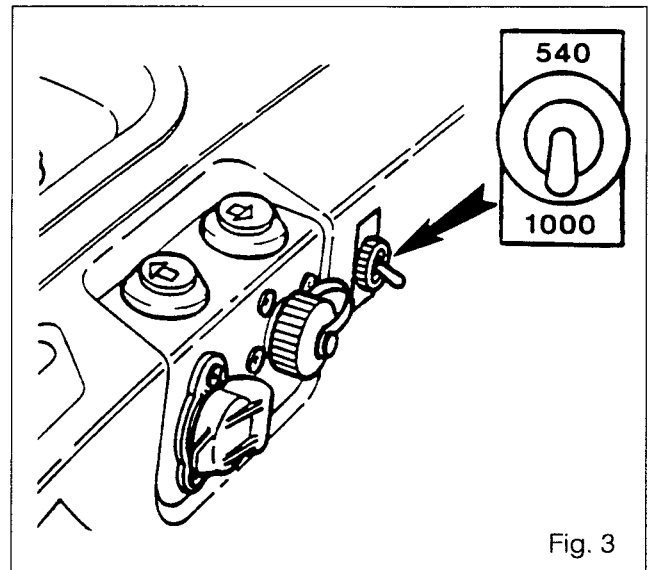

Fig. 3

#### 4. Modification of the forward speed programming

- Remove the upper and lower dashboard trim panels.
- Disconnect the three harness connectors and remove the dashboard.
- Remove the black plug from the back of the dashboard to have access to the micro-switches.
- Using a screwdriver, position the micro-switches No 1 to 5 following the programming codes defined in chart § 5 :
  - . column (2) for a tyre combination with smaller rolling circumferences.
  - . column (3) for a tyre combination with larger rolling circumferences.
- Refit the black plug.
- Connect the harness connectors (Fig. 4).
- Refit the dashboard and its trim panels.



## 6100 SERIES TRACTORS



12A01.6

### Cab - Instrument panel

#### 5. Programming chart for the forward speed shown by the dashboard digital display.

Models	(1) Standard tyre programming						(2) To decrease the speed shown						(3) To increase the speed shown					
	1	2	3	4	5	N	1	2	3	4	5	N	1	2	3	4	5	N
6110-6120-6130-6140	1	1	1	0	0	110.3	0	1	1	0	0	105.4	0	0	0	1	0	115.5
6150-6160-6170	0	1	1	0	0	105.4	1	0	1	0	0	100.6	1	1	1	0	0	110.3
6180-6190	0	0	0	1	0	115.5	1	1	1	0	0	110.3	1	0	0	1	0	121

N = Number of pulses/sec. from the sensor (in Hertz) for 10 Kph (6.24 Mph)

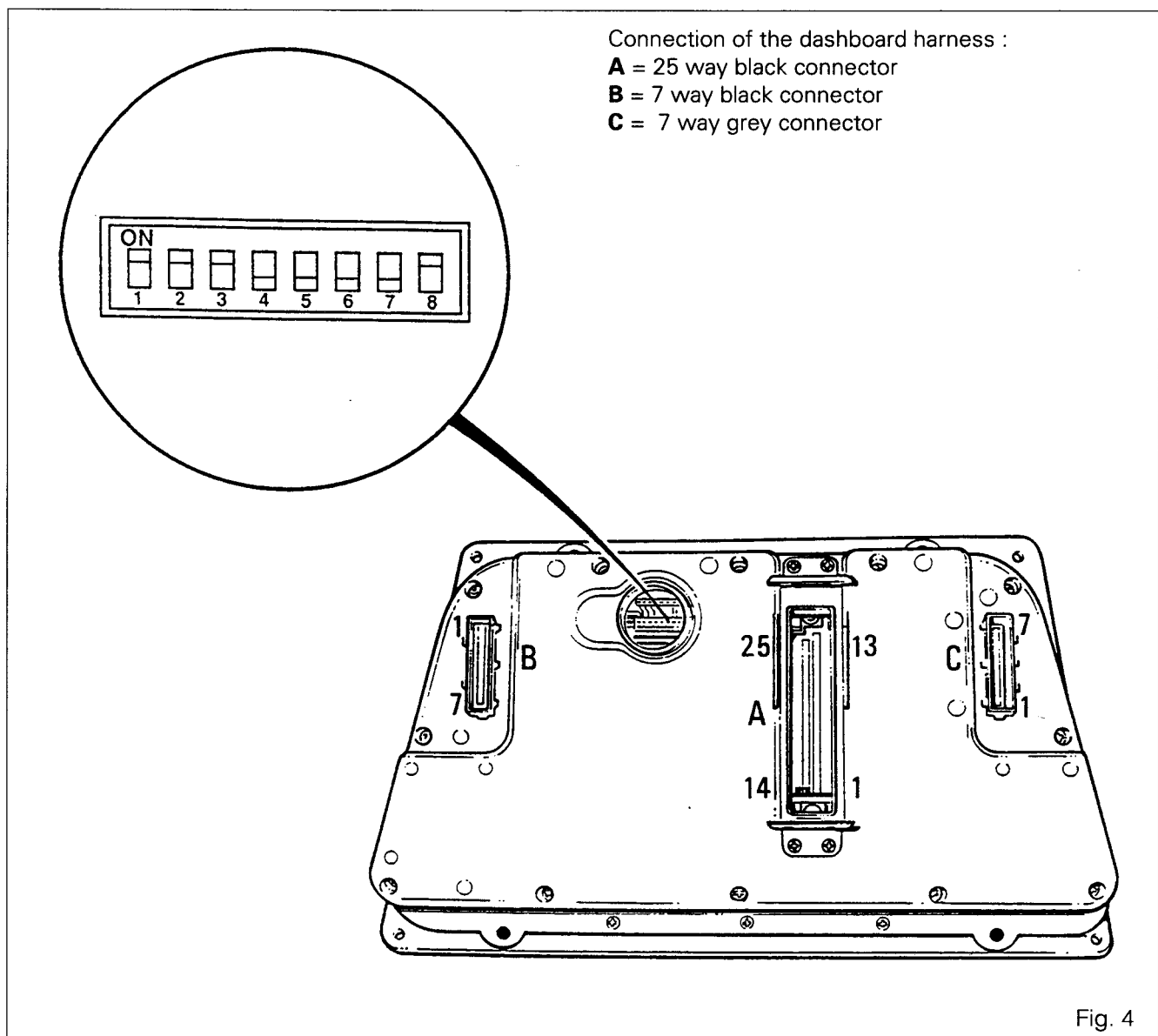



*12 B01 Air conditioning*

CONTENTS

<b>A. General</b>	_____	<b>2</b>
<b>B. Schematic diagram</b>	_____	<b>3</b>
<b>C. Technical characteristics</b>	_____	<b>5</b>
<b>D. Safety instructions</b>	_____	<b>8</b>
<b>E. General maintenance</b>	_____	<b>8</b>
<b>F. Checking and preventive maintenance</b>	_____	<b>9</b>
<b>G. Wiring diagram</b>	_____	<b>10</b>
<b>H. Service tool</b>	_____	<b>10</b>



12B01.2

## 6100 SERIES TRACTORS



# Cab - Air conditioning

### A. General

Suitable control of the internal environment of the cab of an agricultural implement requires:

- that the temperature and humidity in the cab should be within a range that is compatible with human comfort,
- the supply of fresh filtered air to keep the cab under pressure and to prevent the ingress of impurities,
- the de-icing of windows to ensure visibility in all directions.

Moreover, the distribution of air should be such that no difference in temperature can be detected within the cab, especially over the body surface of the driver.

In addition, the air conditioning system must be designed to withstand mechanical stresses caused by the numerous impacts and vibrating stresses associated with applications in the context of agricultural work.

Finally, it is of critical importance that the system should operate satisfactorily in the muddy and dusty conditions associated with agricultural work. The equipment must also be capable of operating in positions corresponding to an angle of tilt that may reach 16° from the horizontal.

### The cooling principle

There is no known method of producing cold: only the absorption of heat is possible. Air conditioning is a process by which heat is taken out of the air. Temperature is measured by the quantity of heat in a given substance. Like water, which always runs from a high point to a low point, heat always «runs» from a hot body to a cold body. Consequently, in order to condition the air or absorb heat from the air in a cab, the warm air must be placed in contact with a cold surface.

It is a physical property of liquids that they boil or evaporate at a specific temperature when at a given pressure.

In the vaporising process which takes place at a constant temperature, the liquid absorbs a considerable amount of heat. One example is that, at normal atmospheric pressure, water boils or vaporises at 100°C (212°F). A considerable quantity of heat can be absorbed by the water but its temperature will not rise. The same principle applies if heat is removed: steam returns to the liquid state or liquids become solid. When pressure is controlled in a closed circuit, a liquid can be maintained at low pressure and with a low boiling point. During vaporisation, the liquid absorbs heat from its environment.

### The cooling cycle

Air conditioning in the cab is provided by means of a ventilation system. During cold weather, the cab is supplied with filtered air that has been heated by pipes containing hot water from the engine. When the ambient temperature is too high and makes it uncomfortable to drive the tractor (in the summer), a compressor-based cooling system allows the temperature in the cab to be reduced by several degrees. In an air conditioning unit, a refrigerant circulates in a closed circuit under pressure. This refrigerant is the R134a (HFC). At specific points in the circuit, the gas is subjected to pressure and temperature modifications.

A compressor, which is belt-driven by the engine, sucks in vapour to maintain a low pressure on the upstream side in the evaporator and compresses the resulting gaseous refrigerant by directing it to a cooling unit known as the condenser. The passage of air across the condenser located in front of the engine water radiator cools and condenses the gaseous refrigerant. The refrigerant which has become liquid is filtered. Humidity and impurities are removed by a filter which also has the function of acting as a temporary reservoir. This filter is known as the receiver-drier.

The liquid R134a refrigerant under high pressure is directed to the expansion valve which governs the liquid's flowrate. The pressure is relieved, bringing about a considerable drop in temperature and pressure. The liquid under low pressure starts boiling and evaporating in a heat exchanger or evaporator. The warm, humid air in the cab is pulsed through the evaporator by turbine fans, cools on contact and is driven into the cab. The humidity in the air condenses in the evaporator and is discharged outside the cab through pipes. The cycle is completed when the gas is returned to the compressor.

According to the desired temperature in the cab, a thermostat with an «off» position causes the compressor to be automatically engaged and disengaged by means of an electromagnetic clutch.



# Cab - Air conditioning

12B01.3

## B. Schematic diagram

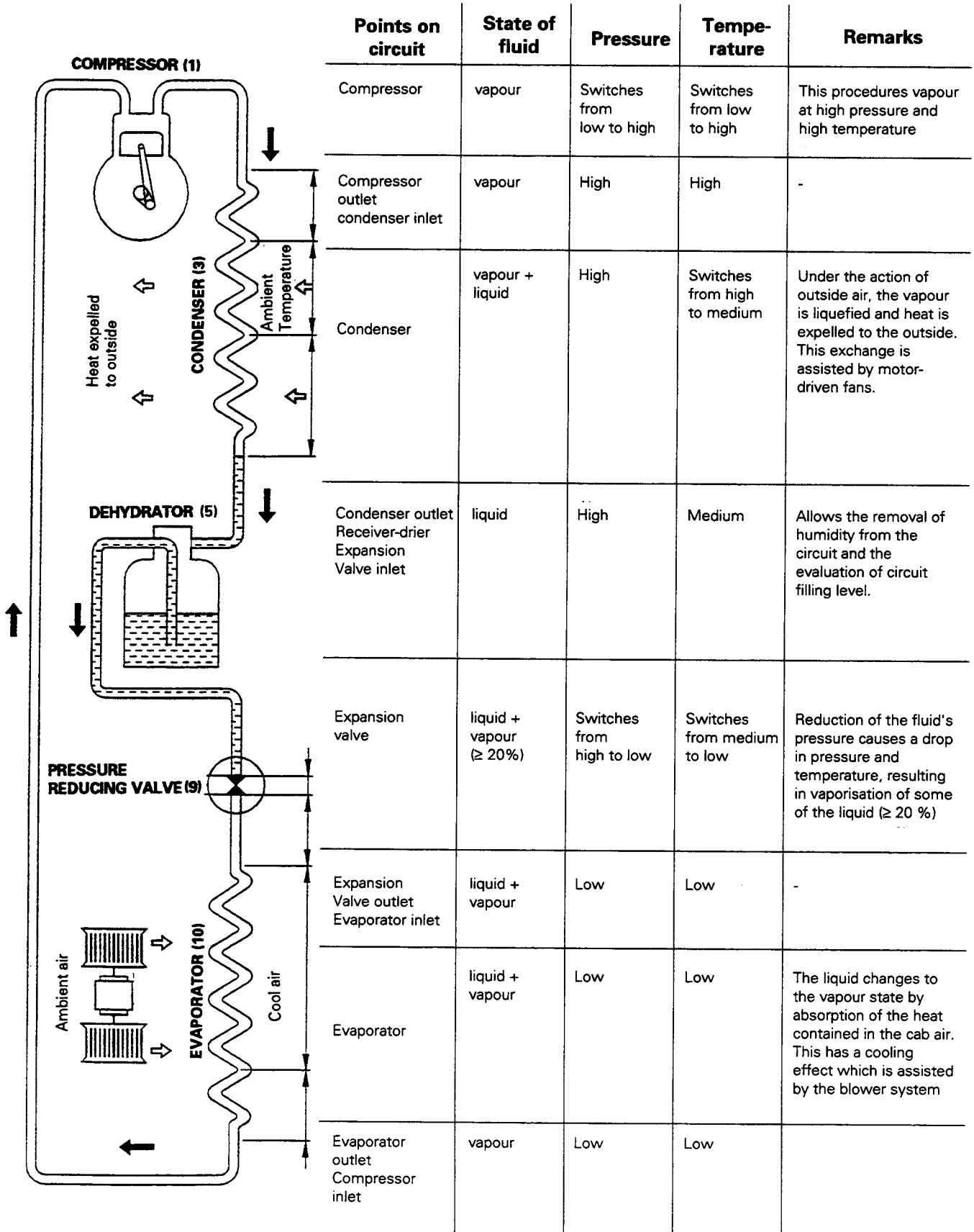



12B01.4

## 6100 SERIES TRACTORS

**Cab - Air conditioning**

Fig. 1

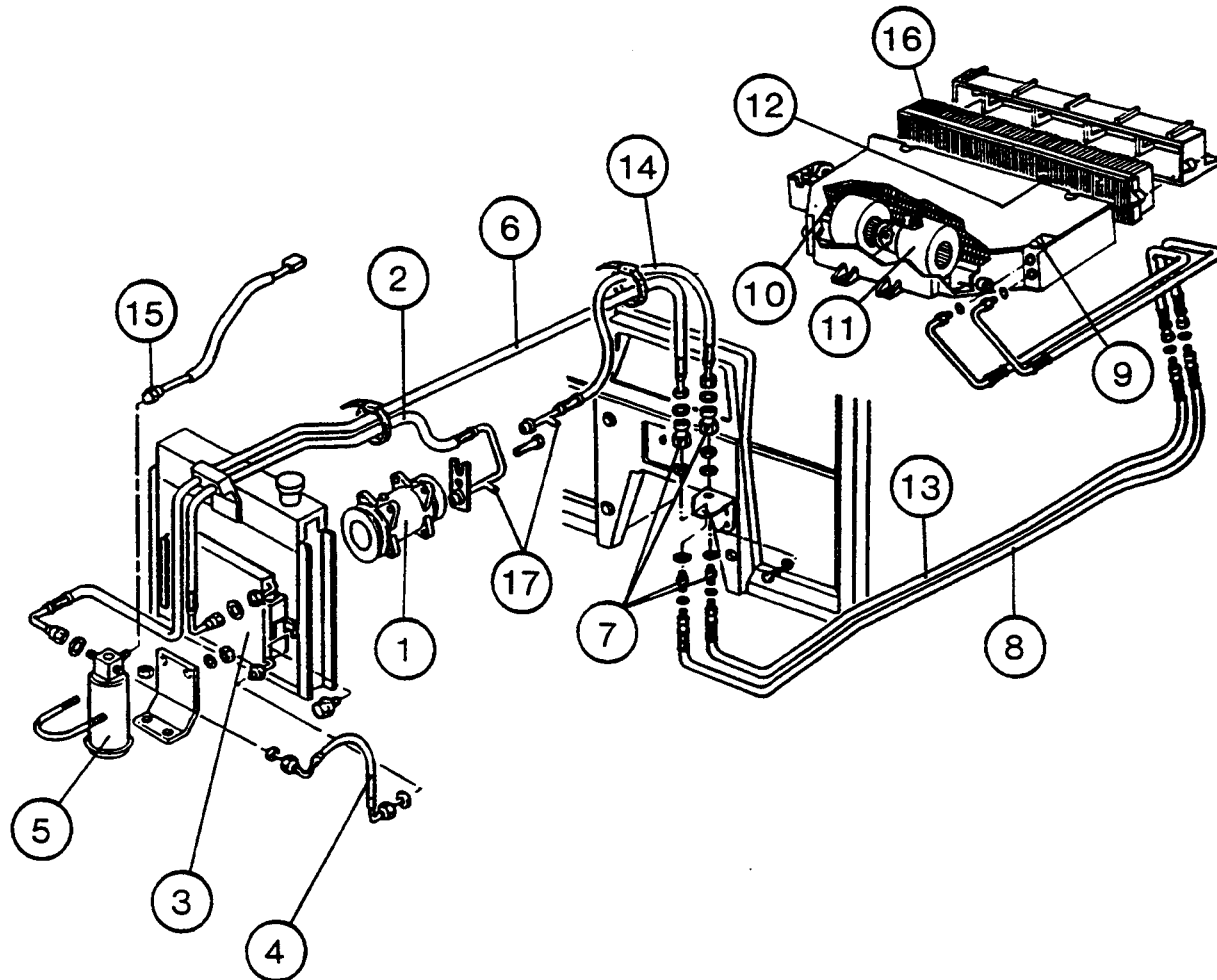
**List of parts**

- |   |   |
|---|---|
| (1) Compressor with electromagnetic clutch                | (10) Evaporator (integrated in heating system)              |
| (2) High-pressure pipe (compressor to condenser)          | (11) Motor fan  |
| (3) Condenser   | (12) Thermostat   |
| (4) High pressure pipe (condenser to receiver-drier)      | (13) Low pressure pipe (evaporator outlet to quick coupler) |
| (5) Receiver-drier  | (14) Low pressure pipe (quick coupler to compressor)        |
| (6) High pressure pipe (receiver-drier to quick coupler)  | (15) High / Low pressure switch                             |
| (7) Quick couplers  | (16) Cab filter   |
| (8) High pressure pipe (quick coupler to expansion valve) | (17) Service ports  |
| (9) Expansion valve                                       |   |



---

**6100 SERIES TRACTORS**

---



12B01.5

**Cab - Air conditioning**

---

**C . Technical characteristics**

---

**1. General**
**Compressor**

- Make .....	Sanden
- Type .....	SD-7H15
- No of cylinders .....	7
- Oil capacity .....	190 cc (6.69 fl oz)
- Drive belt	
Tension .....	108 - 122 Nm (80 - 90 lbf ft)
Deflection .....	12 - 15 mm (1/2 - 5/8)
- Weight .....	7.5 kg (16.5 lb)

**Electro magnetic clutch**

- Voltage .....	12 V
- Current .....	3.6 - 4.2 amps
- Air gap .....	0.4 - 0.8 mm (0.016 - 0.031 in)

**Torque specifications**

- Clutch retaining nut .....	30 Nm (22 lbf ft)
- Cylinder head cap screws .....	34 Nm (25 lbf ft)
- Service port with O-ring .....	15 Nm (11 lbf ft)

**Air conditioning system**

- Refrigerant type .....	R-134a
- Capacity .....	1.7 kg (3.75 lb)
- Operating pressure and temperatures	
Ambient temperature at 30 - 40 ° C (86 - 104 ° F) at sea level	
- Low side pressure .....	0.3 - 0.65 bar (4.3 - 9.4 lbf in <sup>2</sup> )
- High pressure side .....	12 - 18.5 bar (174 - 268 lbf in <sup>2</sup> )

**Combined hig/low pressure switch**

- Descending cut-out pressure .....	2 bar (29 lbf in <sup>2</sup> )
- Ascending cut-out pressure .....	27 bar (392 lbf in <sup>2</sup> )

**Temperature control**

- Range .....	1 - 20° C (34 - 68 ° F)
- Differential .....	4° C (7° F)





12B01.6

## 6100 SERIES TRACTORS



### Cab - Air conditioning

## 2. Components

### Compressor and electromagnetic clutch

#### Compressor

The compressor, its clutch and the pulley constitute a removable assembly.

This assembly compresses the low-pressure gaseous refrigerant to high pressure and ensures circulation of the refrigerant through the system.

#### Electromagnetic clutch

This allows the compressor to be engaged and disengaged according to the evaporator temperature. The coupling consists of two main components: the stationary induction coil (permanent induction field) and the rotor.

The induction coil is fitted directly on the compressor. The grooved pulley is fitted on the tapered end of the crankshaft.

The current transmitted by the temperature control switch generates a magnetic field and the rotor disk is magnetically attracted against the pulley. The compressor runs. When the current is switched off, the rotor is demagnetized and the mechanical coupling is thus disengaged.

**If parts are replaced:** evaporator, condenser, receiver-drier, compressor or expansion valve, the circuit must be drained, taking the precautions specified in the next section and performing the operations in the correct order.

### Condenser

The condenser receives the gaseous refrigerant under high pressure and at high temperature from the compressor and transforms it into pre-cooled liquid in the high-pressure state. It is designed to withstand variations in the temperature of the hot, gaseous refrigerant and cold outside air. When the refrigerant is cooled, the gas becomes liquid. This cooling is obtained by passing a stream of cool air (according to the vehicle's speed and the capacity of the motor fan). The temperatures of the refrigerant in the condenser vary between 49°C and 77°C for pressures of between 10.5 kg/cm<sup>2</sup> and 21 kg/cm<sup>2</sup>.

#### **If the condenser has to be replaced:**

- Avoid damaging the cooling fins in order to ensure the appliance's maximum efficiency.

### Receiver-drier

The receiver-drier is an important component of the air conditioning system. It is supplied with liquid refrigerant from the condenser and removes any humidity and foreign bodies which may have entered the system.

The receptacle is used for temporary storage of the refrigerant, according to the requirements of the expansion valve.

The circulation of refrigerant in the circuit can be checked on the warning light located above this reservoir.

This part also acts as a filter (similar to an engine oil filter) and **must be replaced at least every 1,000 hours or every three years, or when any servicing action requires recharging the circuit.**

#### **When installing or replacing the receiver-drier :**

- Check the correct connection on pipes on the IN side to the condenser.
- Remove the rubber protective covers from the couplings at the last moment in order to avoid the entry of any dampness.
- All the seals must be replaced after disassembly and the new seals must be lubricated when fitted. These are special seals.

### Expansion valve

This valve, located on the evaporator inlet, controls the quantity of refrigerant entering the evaporator and reduces the pressure of the refrigerant. It automatically governs the flow of refrigerant to the evaporator according to the amount of heat.

It reacts according to the temperature of its sensitive element and to the pressure of the liquid.

In order to avoid any excessive pressure drop in the evaporator, the valve is equipped with a compensating system with a bulb which takes into account the temperature of the gas on outlet from the evaporator. This bulb is also connected to the valve diaphragm.

#### **If the valve is replaced:**

- Always lightly lubricate the couplings with oil for refrigerant.
- Check that the needle operates correctly before fitting by spraying liquid refrigerant onto the bulb and checking the movement of the needle.
- Check that the valve is correctly connected.
- Handle the capillary tubes with care.
- When fixing the heat-sensitive element (the bulb) onto the pipe, clean the pipe to ensure good contact. Secure the bulb onto the pipe with the clip provided and insulate with insulating fabric.



## Cab - Air conditioning

### Evaporator

The purpose of the evaporator, located behind the turbine fans, is to cool and dehumidify the ambient air. In the evaporator, the liquid refrigerant which is at low pressure and low temperature after passing through the expansion valve, boils and starts evaporating immediately.

This process absorbs the heat from the air sucked in from the cab.

### Motor fan

A permanent magnet type motor drives two turbine fans each of which is protected by an air nozzle unit. The assembly is fitted on an insulated support bracket. A resistor system connected to the main switch allows the motor to run at three speeds.

### Thermostat

The thermostat controls the operation of the compressor by means of its electromagnetic clutch. This is a capillary type thermostat which controls an electrical switch.

It has an adjustable range so that a preset temperature in the cab to be selected.

The capillary tube measures the temperature in the evaporator and controls the operation of the switch by the expansion of its gas.

#### If the thermostat has to be replaced:

- Handle the capillary tube with care.
- The capillary tube must be in contact with the evaporator pipe and the pressure-reducing valve side.

### High/Low pressure switch

The pressure switch, located on the high pressure circuit, is fitted on the receiver-drier and is wired in serie with the compressor clutch circuit.

It provides protection to the system by cutting out the clutch circuit when an excessive pressure drop or increase occurs in the high pressure circuit.

Switch working pressure	
Interlock	Cut-out
2.1 bar	2 bar
	27 bar

### Quick couplers

The quick couplers are installed on the high and low pressure circuits, on the L.h.s. of the tractor in front of the cab, to enable the tractor to be split without having to discharge the system. They facilitate separation between the engine and transmission and cab removal.

**During these operations, seal the couplers using the plug kit 3376935M91 (see § H).**

### Service ports

The service ports located on the high and low pressure pipes on the back of the compressor are of quick male coupler type.

### High and low pressure pipes

The hoses are in nylon lined nitrile.

**To avoid damage to the hose nylon insert, do not attempt to bend the hoses beyond the radius given in the chart below :**

Hose external diameter	Curvature radius min
18 mm	86 mm
21 mm	105 mm
26 mm	130 mm



12B01.8

---

## 6100 SERIES TRACTORS

---



# Cab - Air conditioning

---

### D. Safety instructions

---

It is very important to work in a clean environment in order to prevent the ingress of any dirt into the system. Carefully clean couplings and, then, lightly lubricate them with compressor oil before making the connections.

Do not blow compressed air into the pipes to remove any particles which might be there: use only refrigerant for that purpose.

Do not remove pipe protective coverings until the last moment. Cut hoses using a knife: never use a saw. Carefully plug pipes when they are stored. The oil contained in the air conditioning circuit is a refrigerating oil. It is miscible with refrigerant.

#### Precautions to be taken

An air conditioning unit can be a dangerous piece of equipment which may be compared to a high-pressure steam boiler. The pressure of the refrigerant is always greater than at its normal boiling point. If a rupture occurs on a pipe, the refrigerant will evaporate or boil extremely quickly.

The forces generated by expansion can be very dangerous. A refrigeration technician must always work with care to prevent any uncontrolled escape of refrigerant. R134a refrigerant is non-flammable, non-toxic (except when in contact with an open flame) and non-corrosive (except in contact with water).

Great care must be taken when handling R134a refrigerant. It can freeze the skin or the eyes on direct contact.

**In contact with an open flame or at high temperature, it decomposes to produce phosgene gas which is deadly poisonous.**

Never handle refrigerant without wearing safety goggles and gloves.

Never attempt to drain a system by loosening a coupling. Slow draining without any danger can only be carried out using an evacuating/charging station dedicated to R134a refrigerant (see section 12C01).

Never drain the system in a room where there is a flame. The same precautions must be taken when checking for leaks.

When it is necessary to retighten a coupling, use two wrenches so as to avoid deformations which may cause leaks.

Never weld or clean with steam near a filled system as this may result in excess pressure and result in leaks.

Do not store R134a refrigerant in direct sunlight or near a source of heat or in a wet place. Always reinstall the bottle safety devices when not in use. Avoid subjecting the bottle to impacts. Do not carry the bottle in the passenger compartment of a vehicle.

#### In case of accident with R134a

If R134a refrigerant comes into contact with the eyes, wash them immediately with cold water. Call a doctor immediately.

**Note: Frostbite caused by the liquid refrigerant can be treated by gradually warming the injured area with cold water and then applying a cream for dry skin. Call a doctor immediately.**

---

### E. General maintenance

---

**Very important: Before switching on the air conditioning system, check that windows and doors are properly closed. The interior of the cab must be kept as clean as possible. If, for any reason, the cab cannot be fully closed, the air recycling system must be switched off. If these recommendations are not complied with, the evaporator may be clogged and this will stop the air conditioning system and may damage the compressor.**

To ensure that the system operates correctly, the filter located at the back of the cab, the condenser, the fans and the evaporator must be periodically checked. Any clogging results in increased high and low pressure and reduces the cooling efficiency. The tension of the driving belt and its alignment must be checked.

Check the condition of the pipes carrying condensation water from the evaporator. Any accumulation of water in the tray may cause the evaporator to ice up and stop the refrigerant circulating, so reducing the system's efficiency.

To keep the system in good condition, it is advisable to run the system for a few minutes each week in order to lubricate all the components, as the oil in the compressor is miscible with refrigerant.



## Cab - Air conditioning

### Electrical system

For the purposes of electrical checks, it must be ensured that the fuse or pressure switch located on the receiver-drier are in good condition. A failed fuse will have been overheated and will be deformed so that it will not allow power supply to the compressor.

To check that the electromagnetic clutch is actuated, set the fan switch to the low or high speed position and then position the air conditioning switch on the maximum cold position: a click should be heard.

After a few minutes in operation, you should notice the successive switching on and off of the electromagnetic clutch.

The connecting wires must be in good condition.

### Caution:

When restarting the compressor, especially if it has not been operated for some time, proceed in the following manner to ensure correct lubrication as soon as the compressor starts running:

- switch on the electromagnetic clutch.
- crank over the tractor engine for a few seconds with the fuel supply cut off.
- disconnect the electric stop button and allow the engine to idle for a few minutes.

Visually check the quantity of refrigerant (without bubbles) and its colour through the sight glass in the receiver-drier reservoir, while operating the engine at maximum revs (with the fan and the thermostat set to the maximum cold position).

**Note: On starting and stopping, the presence of bubbles is normal. If a brown or bluish colouring can be seen through the sight glass: drain the system, change the lubricating oil in the compressor and the receiver-drier, and if necessary change the expansion valve, in that order.**

### F. Checking and preventive maintenance

- Carry out the checks and maintenance operations described in preceding paragraphs.
- Visually check the evaporator, pipes, condenser, receiver-drier, compressor, couplers and belt, and the flow of condensation water on the evaporator.
- Carry out an "internal" check with low-pressure gauge (blue), high-pressure gauge (red), engine at 1500 rpm, thermostat on maximum cold position and fan on high speed.
- Check temperature of components.  
The output from the expansion valve (on the evaporator side), the evaporator, the low-pressure pipes and the «inlet valve» on the compressor must be cold to the touch.  
The condenser, the receiver-drier, the inlet to the expansion valve, the compressor and «delivery valve», and the high-pressure pipes must be hot to the touch.
- The receiver-drier filter and oil should be changed at least every 1000 hours or every three years, or when any servicing action requires recharging the circuit.**
- If the circuit is overfilled (more than 2 kg of R134a refrigerant), there is a danger of blockage at the receiver-drier and expansion valve.
- If the high and low pressure are equal when the air conditioning unit is operating, this means the compressor is faulty.
- If there is water in the circuit, the expansion valve (needle valve) will be blocked by a drop of water which will freeze to form ice, so decreasing the low and high pressure values.



12B01.10

## 6100 SERIES TRACTORS

**Cab - Air conditioning****G . Wiring diagram****List of parts**

- (1) 4-way fan switch
- (2) Air conditioning thermostat
- (3) Pressure switch on HP circuit protecting the system by cutting out power supply to the clutch when high pressure is too low or too high (2 bar or 27 bar).
- (4) Electromagnetic clutch
- (5) Motor fan

**Colour of wires**

- B/N : Blue and black  
 J/N : Yellow and black  
 M : Brown  
 N : Black  
 O : Orange  
 R : Red  
 Vi : Violet

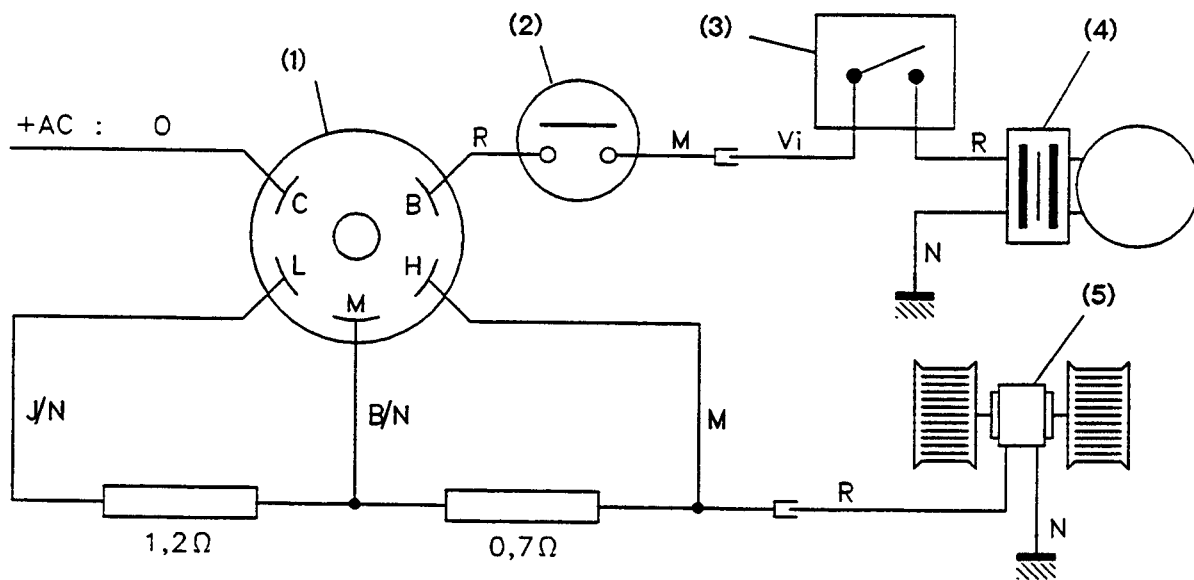
**H . Service tool**

(3376935M91 - Plug kit for quick couplers on high and low pressure circuits

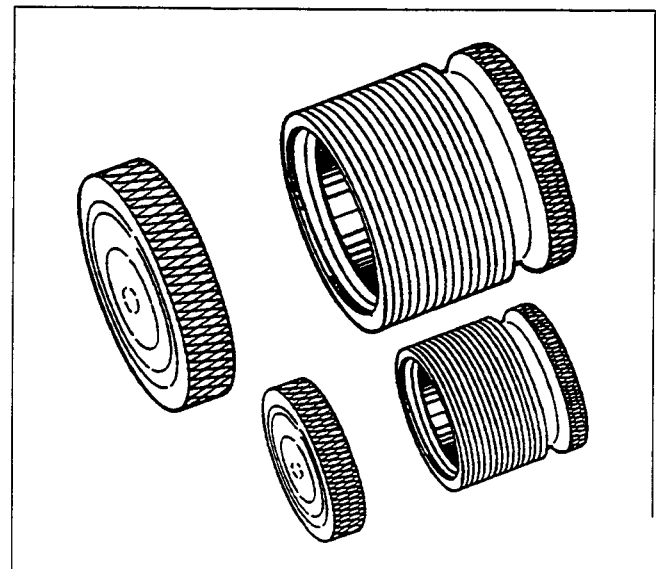



**Cab** - Recharging the system

12C01.1

*12 C01 Recharging the system*

CONTENTS

-	<b>Recommendation</b> _____	<b>2</b>
A.	<b>Discharging the system and checking for leaks</b> _____	<b>2</b>
B.	<b>Evacuating and flushing the system</b> _____	<b>3</b>
C.	<b>Recharging the system</b> _____	<b>4</b>
D.	<b>Checking the pressures</b> _____	<b>5</b>
E.	<b>Service tools</b> _____	<b>6</b>



## Cab - Recharging the system

### Recommendation

All the operations described in this section must be carried out using imperatively a service equipment (evacuatin/charging station, refrigerant recovery station, refrigerant leak detector,...) dedicated for R134a refrigerant (see § H).

### A. Discharging the system and checking for leaks

#### Discharging the system

This operation must be carried out in well-ventilated premises.

Avoid any open flame. Smoking must be prohibited. Prepare the system for discharging by running the engine for a few minutes at 1,000 rpm with the air conditioning unit set to the maximum cooling position. Stop the engine and switch off the air conditioning unit. Connect the manifold equipment to the service ports on the back of the compressor (Fig. 1) :

- red hose on high pressure
- blue hose on low pressure

**Slowly** open the manifold **low pressure** valve.

**Warning: If the system is discharged too quickly, compressor oil will be carried out with the refrigerant.**

After a few minutes, when the pressure has dropped by 1.5 to 2 bar (22 to 29 PSI), **slowly** open the manifold high pressure valve to allow all the refrigerant to escape.

#### Checking for leaks

When the system is empty, replace any faulty parts and then flush the system with R134a refrigerant by sealing with gas under a pressure of 2 to 3 bar (29 to 44 PSI). To do this, connect the middle hose between the pressure gauges to the upper connector on the charging cylinder (Fig. 4). Slightly loosen the middle bypass hose connector to bleed the air from the hose and then retighten it.

Open the taps on the high and low pressure gauges and allow the R134a refrigerant gas to build up a pressure of between 2.5 and 3 bar (36 to 44 PSI) in the system. Shut off the taps and leave the system charged at this pressure for between 15 to 20 minutes before checking for leaks.

**Note: Make sure that all the taps are closed before handling the hoses in order to avoid accidents.**

Use an electronic leak detector (Fig. 2), and run the end of its hose over:

- a) the compressor valve connectors,
- b) all the compressor seals: shaft rotary seal, oil reservoir plug seal.

#### Repeat discharging of system

Discharge the system again by allowing the gas to escape through the high and low pressure taps, leaving a residual pressure of between 0.2 and 0.3 bar (3 to 4.4 PSI).

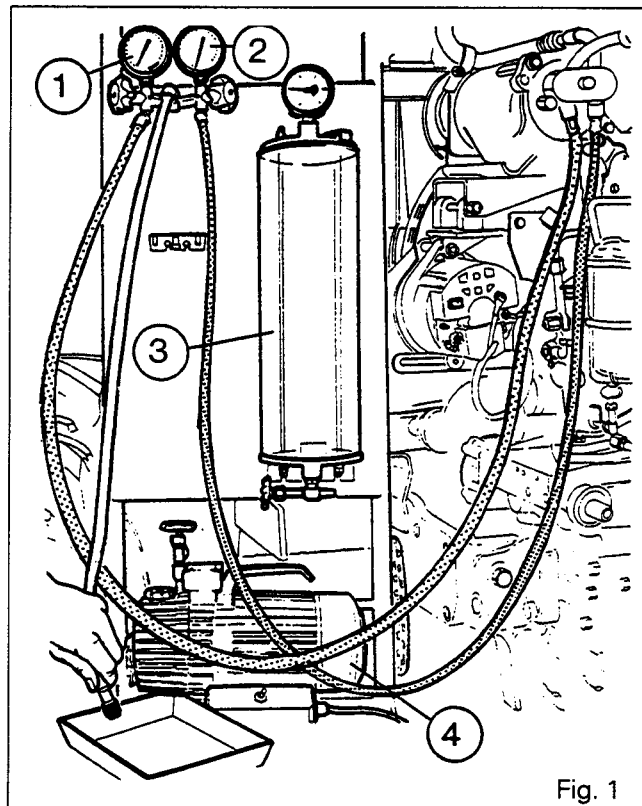

Fig. 1

- (1) Low pressure gauge
- (2) High pressure gauge
- (3) Charging cylinder
- (4) Vacuum pump

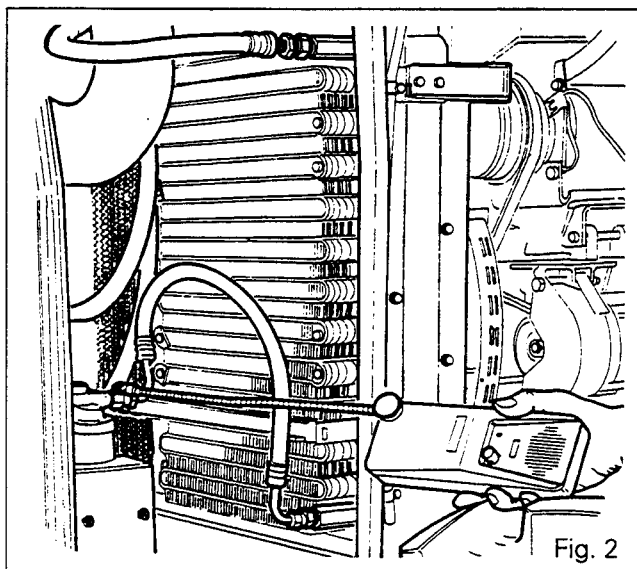

Fig. 2



## Cab - Recharging the system

12C01.3

### B. Evacuating and flushing the system

#### Evacuating the system (Fig. 3)

When the system is no longer under pressure, connect the middle hose to the vacuum pump. Open the high pressure tap (with the low pressure tap already open). Open the tap on the vacuum pump and start up the pump.

**Note:** At ambient temperatures above 20°C (68°F), a sufficient vacuum is generally obtained in 30 minutes, in two 15-minute periods. If the ambient temperature is lower than 20°C (68°F), it will take at least 60 minutes, especially if the relative humidity is high. At the end of the evacuating period, the low pressure gauge should indicate a partial vacuum of 635 to 711 mm (25 to 28 inches) of mercury.

Close the high and low pressure taps and the vacuum pump tap, and switch off the pump.

#### Flushing the system (Fig. 4)

Disconnect the middle by-pass hose from the vacuum pump and connect it to the top of the charging cylinder. Open the top tap on the charging cylinder, slightly loosen the middle by-pass hose in order to bleed any air from the hose and retighten the connector when R134a refrigerant starts to escape from the hose.

Open the high and low pressure by-pass taps to obtain an R134a gas pressure of between 2.5 and 3 bar (36 to 44 PSI).

Close the taps and leave the charged system for 20 minutes.

Using the leak detector, check the system for leaks again (Fig. 2).

#### Discharging and evacuating the system (Fig. 3)

Purge the system by slightly opening the low pressure by-pass tap and allowing R134a refrigerant to escape. Close the tap when a residual pressure of between 0.1 and 0.2 bar (1.4 to 3 PSI) is obtained on both pressure sides.

Connect the middle hose to the vacuum pump.

Open the high and low pressure taps and let the vacuum pump run for 20 minutes.

Close the high and low pressure taps after ensuring that the low pressure gauge indicates a partial vacuum of between 634 and 711 mm (25 to 28 inches) of mercury. When all these operations have been carried out, the system is ready for recharging with R134a refrigerant.

**Note:** The air must be bled from the hoses each time they are connected to the pressure gauges and charging cylinder.

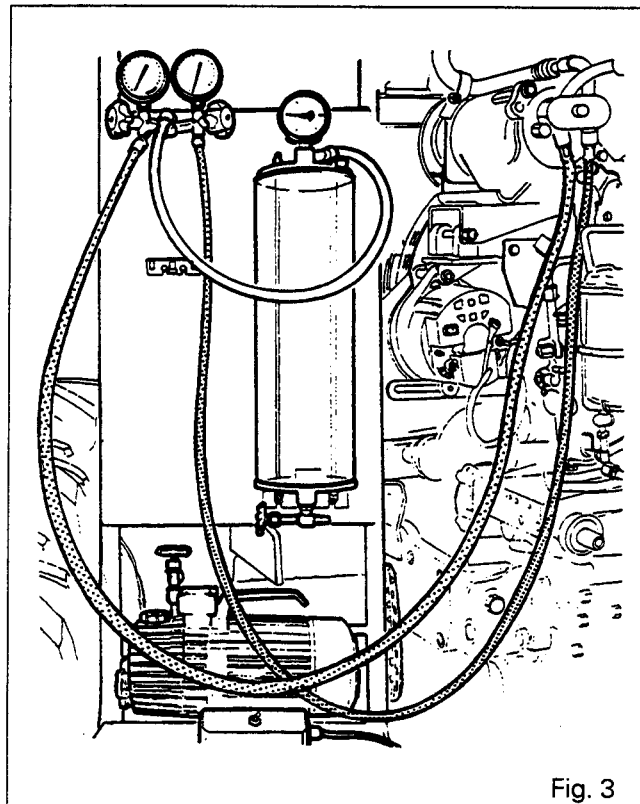

Fig. 3

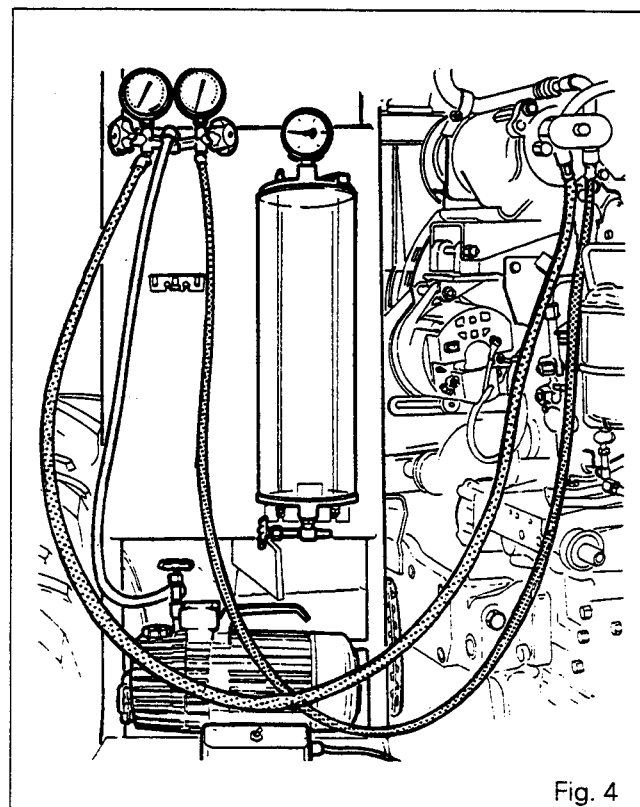

Fig. 4





### C. Recharging the system (engine stopped)

The quantity of refrigerant required to charge the system correctly is 1.7 Kg (3.7 lbs).

#### 1. Instructions for filling the charging cylinder from the refrigerant gas bottle (Fig. 5)

Connect the refrigerant bottle to the bottom of the charging cylinder and tip the bottle upside down. Open the taps. When the pressures are equal in the bottle and in the charging cylinder, bleed gas from the charging cylinder through the top tap until the quantity of refrigerant required for the system is obtained.

#### 2. Connecting the charging system (Fig. 6)

Connect the bottom of the charging cylinder to the middle connector between the pressure gauges.

- Bleed air from the hoses.
- Mark the level of refrigerant on the charging cylinder.
- Slowly open the low and high pressure taps on the pressure gauges in order to charge the system.

**Note: To ensure complete charging with liquid, the pressure in the charging cylinder must be between 6 and 7 bar (87 and 101 PSI).**

When a system is correctly charged and when the pressures are equal, the pressure on both the low and high pressure sides should be between 4 and 5 bar (58 to 73 PSI).

When the charging cylinder is not equipped with a heating element, the system must be partially charged with liquid and then topped up with gas.

#### Partial recharging with liquid and topping up with gas (engine stopped, then running)

When the pressures in the charging cylinder and the system are equal, close the high and low pressure taps as well as the tap on the bottom of the charging cylinder.

To top up with gas, connect the middle hose between the pressure gauges to the top of the charging cylinder, and then purge the hose (by unscrewing the hose slightly and allowing gas to escape for a few seconds).

(Fig. 7). For this operation, open **only the low pressure tap**. Run the engine at between about 1,000 and 1,200 rpm with the air conditioning set to maximum cooling and the fan on maximum speed.

The system is correctly charged when the required level is obtained on the charging cylinder.

At that moment, close the taps on the charging cylinder and on the low pressure gauge.

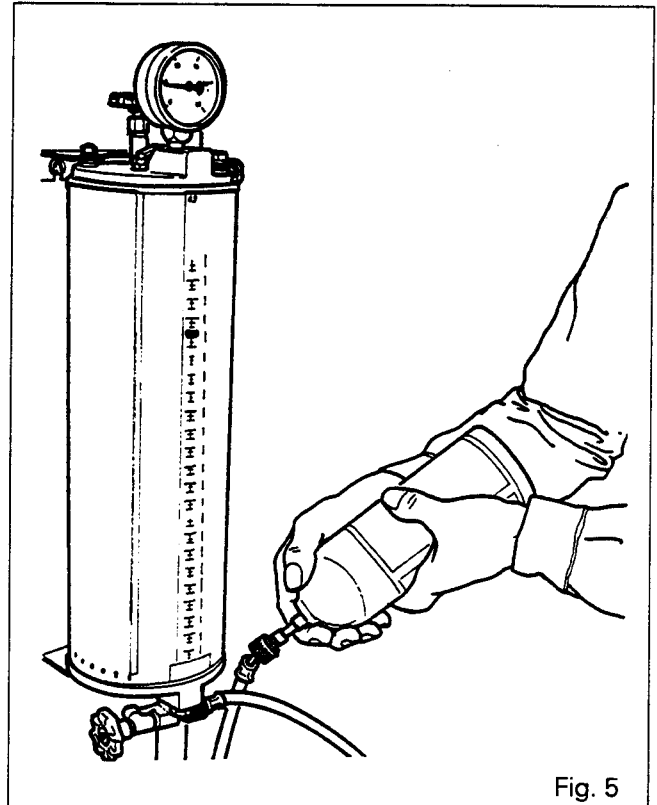

Fig. 5

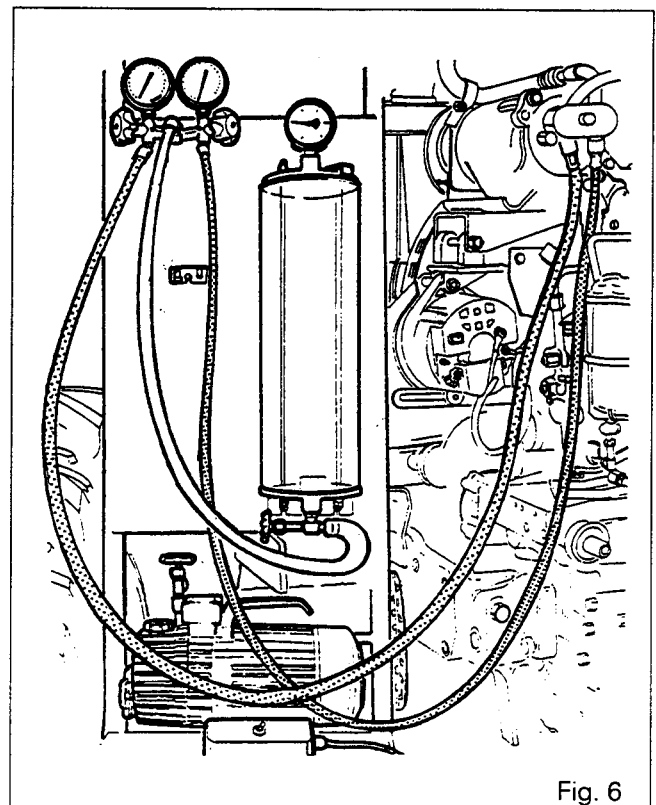

Fig. 6



## Cab - Recharging the system

12C01.5

### D. Checking the pressures

Once charging has been completed, the air conditioning system should be checked for correct operation.

With the pressure gauges connected to the compressor (Fig. 8), run the engine and set the thermostat control to maximum cooling and the fan to maximum speed.

After a few moments' operation, **the high pressure hose should feel hot and the low pressure hose should feel cold.**

No bubbles should be visible in the dehydrator sight glass.

Check the compressor cycles. The compressor operating time should be approximately equal to its shutdown time once the temperature in the cab has stabilized, according to the thermostat setting.

When the air conditioning is switched off, the pressures on the low and high pressure sides should be equal and between 4 and 5 bar (58 and 73 PSI) if the system is correctly charged. **These values vary, however, according to the outside temperature.**

When the air conditioning system is running, the low pressure should be between 0.3 and 0.65 bar (4.3 and 9.4 PSI) and the high pressure between 12 and 18.5 bar (174 and 268 PSI).

All these values depend on the outside temperature. The system should cycle on and off in all cases.

**Note:**

- Fan on maximum speed and thermostat on coldest setting.
- Engine running at 1800 to 2000 rpm.

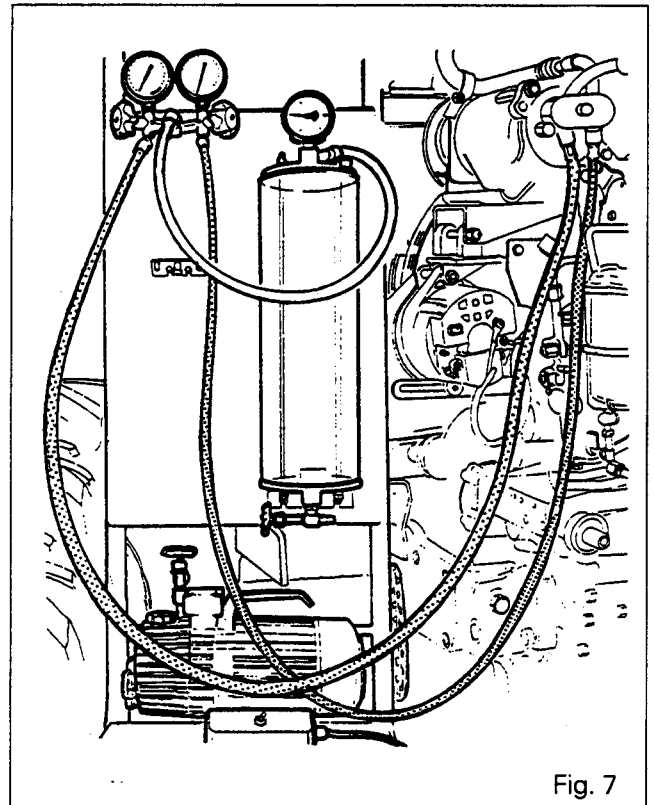

Fig. 7

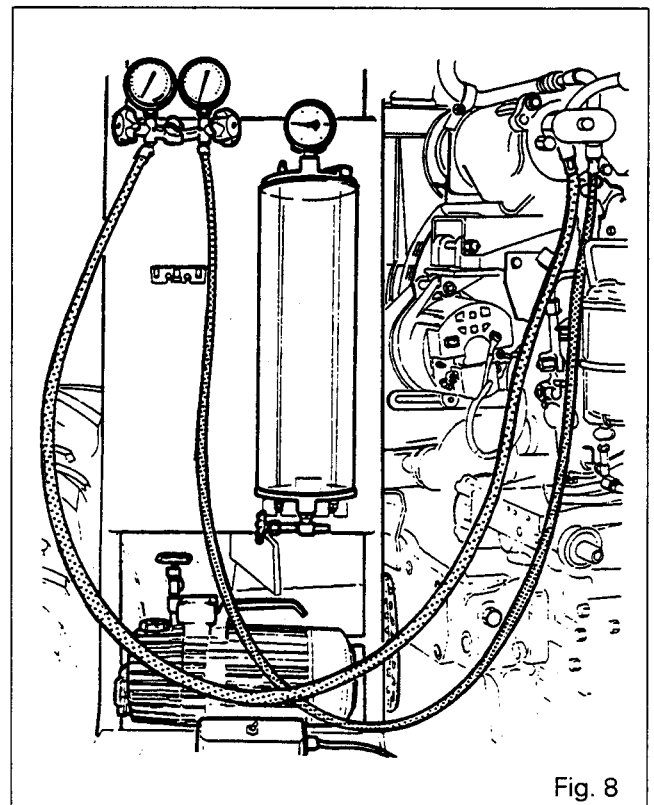

Fig. 8



12C01.6

## 6100 SERIES TRACTORS

**Cab** - Recharging the system**E . Service tools**

Fig. 9

Description	Specification	Part number
Portable evacuatn/charging station	<ul style="list-style-type: none"> <li>• Vacuum pump : 1 cfm 2 stage with anti-oil migration</li> <li>• Charging cylinder of 2200 g (5 lb) capacity</li> <li>• Hoses 1.8 m (72 in) with R134a couplers</li> <li>• Supply : 220/240 V 50 Hz</li> </ul> <p>Options :</p> <ul style="list-style-type: none"> <li>• Compressor oil injection</li> <li>• Absolute (TORR) vacuum gauge</li> </ul> <p>(a) Metric scales (b) Imperial scales</p>	311DAB8QC01 (a) 311CAP8QC01 (b)  311DAB8QC01S (a) 311CAP8QC01S (b)  311DAB8QCB1 (a) 311DAB8QCB1S 311CAP8QCB1 (b) 311CAP8QCB1S
Portable refrigerant recovery station (not shown Fig. 9)	<ul style="list-style-type: none"> <li>• Float switch for automatic shut-off when the tank is 80 % full</li> <li>• 13.6 Kg (30 lb) nominal capacity tank</li> <li>• Without tank</li> </ul> <p>Options :</p> <ul style="list-style-type: none"> <li>• Oil separator : removes oil, acid and particulate matter from refrigerant</li> <li>• Receiver-drier : removes moisture before refrigerant enters the tank</li> </ul>	17621 / PAG  17621ENF / PAG  17651 / PAG
Refrigerant leak detector	<ul style="list-style-type: none"> <li>• Switchable between : R134a and R12</li> </ul>	16500
Vacuum pump oil	<ul style="list-style-type: none"> <li>• Can of 4.5 litres (1 gal.)</li> </ul>	13204
Eye protection goggles	<ul style="list-style-type: none"> <li>• Should ALWAYS be worn when working with refrigerant</li> </ul>	12008

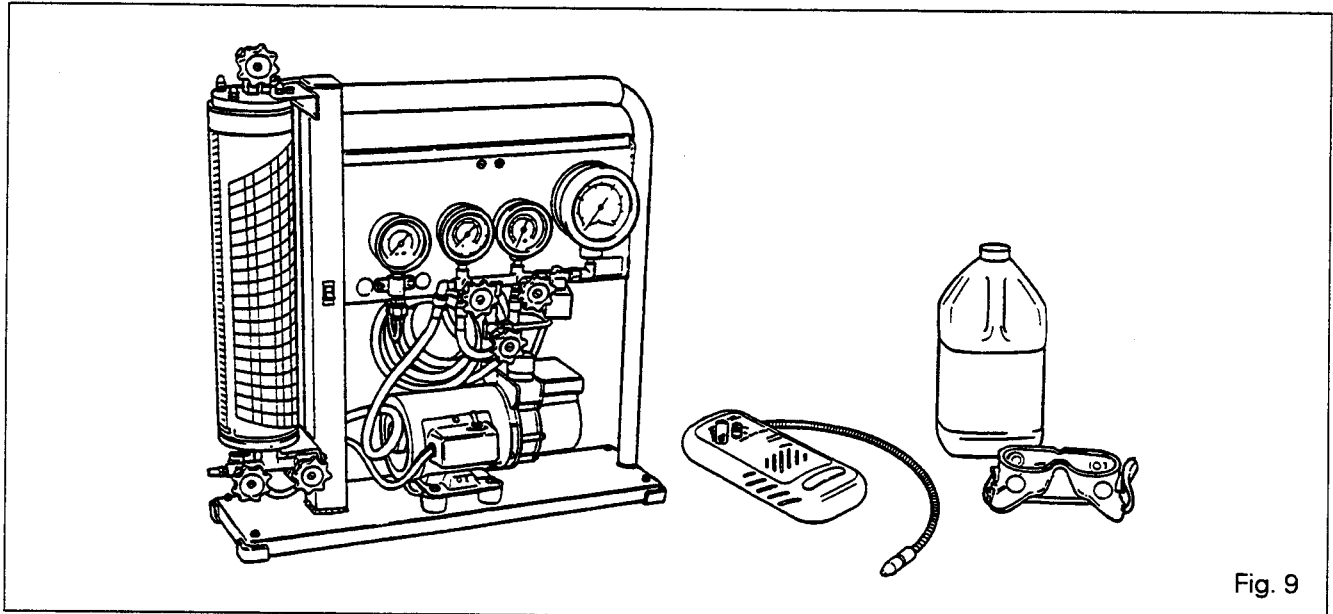

*12 D01 Air conditioning system failures -  
Compressor*

CONTENTS

A.	Diagnosis and failure analysis _____	2
B.	Failure of air conditioning unit _____	2
C.	Compressor _____	4



12D01.2

## 6100 SERIES TRACTORS



# Cab - Failures - Compressor

## A . Diagnosis and failure analysis

### Diagnosis

In general, pressure readings are directly related to atmospheric conditions (pressure and temperature). At ambient temperatures between 30° C and 40° C (86° F and 104° F) at sea level, low pressure readings will vary between 0.3 and 0.65 bar (4.3 and 9.4 PSI) and high pressure readings will vary between 12 and 18.5 bar (174 and 268 PSI). To locate failures, the manifold pressure gauges must be connected to the service ports on the back of the compressor.

### Failure analysis

Leaks in the system will lead to inadequate cooling, and low and high pressures will be too low.

If the system is under-charged, bubbles will always be visible in the dehydrator sight glass, in addition to the symptoms already mentioned.

If the evaporator is dirty or the expansion valve clogged or frozen up, there will be a partial vacuum on the low pressure side and insufficient pressure on the high pressure side.

If the system is over-charged, the expansion valve stuck in the open position or the condenser fouled, the pressure will be too high on the low pressure side.

If the condenser is fouled or the system over charged, the pressure will be excessive on the high pressure side.

### Over-charging problems

In a correctly charged system, the R134a refrigerant discharged from the compressor in the form of gas loses its excess heat resulting from compression in the first coil of the condenser and condenses into a liquid in the subsequent coils. The resulting liquid is held in the last condenser coil before flowing to the receiver-drier. If the system is over-charged, the liquid level rises in the condenser, leaving fewer coils available to condense gas. Both the temperature and pressure then build up causing hoses to burst in some cases.

### Causes of failure with engine running

Over-charging

Worn hoses

Chafed hoses

Hoses cut by sharp edges on sheet metal

Bends too tight

Hoses too close to battery (acid)

### Causes of failure with engine stopped

These are the same as when the engine is running, plus the following:

- shutdown of engine compartment ventilation,
- "temperature surge" caused by the engine immediately after it has been stopped.

The temperature increase when the engine is stopped causes both the temperature and pressure in the air conditioning system hoses to rise.

If a hose is only just holding, it is more liable to burst due to this effect.

This is particularly prevalent in systems that are over-charged with R134a refrigerant and when hoses are worn or badly positioned (in hot spots).

## B . Failure of air conditioning unit

The manifold pressure gauges must be connected to the service ports on the back of the compressor.

### High pressure reading too high

1. Refrigerant over-charge.
  - Purge the system.
  - Avoid leaving the system under-charged.
2. Air in system, in spite of correct low pressure reading.
  - Purge the system.
  - After purging, recharge the system.
3. Space between condenser fins clogged with insects.
  - Clean the condenser.
4. Refrigerant remains in liquid state in suction pipe at evaporator outlet. This causes the formation of moisture or frost on the hose or on the compressor inlet valve.
  - Check that the expansion valve sensing bulb is properly secured in contact with the suction pipe.
5. Plug left in a pipe during assembly. This is indicated by a difference in temperature upstream and downstream of the point where the plug is located.
6. If high pressure reading is higher than the reading obtained during normal operation with correct low pressure reading and correct charge but presence of bubbles in the receiver-drier, then the receiver-drier hose connections have been reversed and fluid is flowing in the wrong direction.
7. If high pressure reading is very high and low pressure reading is normal, with bubbles in the receiver-drier and frosting of the receiver-drier, there is a restriction at the receiver-drier inlet, causing the receiver-drier to act as an expansion valve.



## **Cab - Failures - Compressor**

### **High pressure reading too low**

1. Incorrect charge. A lack of refrigerant is shown by bubbles which appear in the sight glass of the receiver-drier.
2. Compressor gasket cracked or compressor valves leaking.

### **Low pressure reading too low, together with insufficient cooling**

1. Restriction in a hose or in the receiver-drier. This problem can be detected by a difference in temperature upstream and downstream of the restriction or by cooling of the receiver-drier when the system is running.
2. Insufficient charge in the expansion valve sensing bulb.  
Warm up the end of the temperature-sensing bulb in the hand. The intake pressure should quickly rise to at least 1.45 bar (21 PSI) with the engine idling. If it does not, the expansion valve must be replaced.
3. Expansion valve capillary tube broken or leaking.  
The expansion valve stays closed causing the system to operate at very low pressure.
4. Formation of frost in expansion valve or jet.  
The expansion valve or jet may be frosted even though the pipes are hardly frosted at all.
5. Expansion valve stuck. Rust residue in system.  
Heating the end of the bulb has no effect on the low pressure reading.  
The expansion valve may open after a period at rest and then stick again after some time in operation.
6. Check that the evaporator air inlet is not obstructed.
7. Low refrigerant charge.  
Check whether bubbles can be seen in the sight glass when the system is operating with the fans switched on.

### **Low pressure reading too high**

1. Compressor belt too slack.
2. Expansion valve sensing bulb incorrectly installed.
3. Expansion valve needle stuck in the open position.  
Refrigerant flows too freely through the coils and cools or freezes the inlet pipe.
4. Compressor inlet valve filter blocked.
5. Leakage from compressor inlet and outlet valves.
6. If the high pressure reading is low, the low pressure reading is high and the charge is correct, there is leakage from the compressor gasket or valves are faulty.

### **Noisy expansion valve (persistent whistling)**

1. Low refrigerant charge, indicated by the presence of bubbles in the sight glass.

### **Insufficient cooling**

1. Incorrect operation of compressor.
2. Incorrect operation of expansion valve.
3. High and low pressure readings are low, tending to cause partial vacuum with correct charge. Temperature too low at evaporator outlet, causing expansion valve to close and poor synchronization between thermostat cycling and opening of expansion valve.

### **Formation of frost on evaporator fins**

1. Check thermostat electrical contacts.
2. Check that the sensing bulb is in contact with the evaporator fins.

### **Intermittent operation of compressor (irregular cycling)**

- Check belt tension.
- Check clutch drive plate clearance.
- Check clutch coil voltage and current.
- Check compressor.

### **Abnormal compressor noise**

#### **In engaged position:**

- Check installation of compressor.
- Check clutch and that there is no slipping.
- Check R134a refrigerant charge.
- Check clutch and compressor bearings.
- Check quantity of refrigerant oil (190 cm<sup>3</sup>)
- Check compressor inlet and outlet valves.

#### **In disengaged position:**

- Check clutch drive plate clearance.



## C. Compressor

### Setting the clutch drive plate clearance

Check the clearance with feeler gauges. The clearance should be 0.4 to 0.8 mm (Fig. 1).

If the clearance is not the same all the way round, lift slightly and tap gently where the difference is greatest.

**Note: The correct clearance is obtained using shims. When reinstalling the clutch or fitting a new one, try fitting the original shims first.**

**When fitting a new clutch on a compressor, use the following shim sizes: 1.02 mm (0.04016 in) - 0.05 mm (0.00197 in) - 0.12 mm (0.00472 in). Tighten the nut to a torque of 30 Nm (22 lbf/ft).**

### Precautions to be taken when removing and refitting the compressor:

1. Run the air conditioning system for 5 or 10 minutes and discharge the R134a refrigerant (see § A, section 12C01) before removing the compressor.
2. Align the valve plate locating pins to the pin holes in the block and position the plate, the top valve plate gasket and the cylinder head (Fig. 2). The cylinder head low pressure (S) and high pressure (D) connections must be facing upwards and in line with the compressor oil filler hole (Fig. 3).
3. Tighten the 6 cylinder head bolts to a torque of 34 Nm (25 lbf/ft) using the star configuration as shown Fig. 3.

### Filling with oil

**Imperative : Use only synthetic Polyalkylene-Glycol (PAG) oil when filling or topping up the compressor.**

**Recommended oil : SANDEN SP20 PAG**

**Compressor capacity : 190 cc**

Whenever work is carried out on the system and whenever a component has to be replaced (pipes, receiver-drier, condenser), it is advisable to drain the oil from the compressor and refill with the recommended quantity of clean oil instead of topping up.

1. Discharge the R134a refrigerant (see § A, section 12C01).
2. Remove the filler plug.
3. Fill or top up the compressor
4. Refit the filler plug.
  - Check the condition of the O-ring.
  - Check that the O-ring and its seat are clean.
5. Tighten the plug to a torque of 15 Nm (11 lbf/ft). If there is any leak, do not tighten the plug any further but remove it and fit a new O-ring.
6. Recharge the installation with R134a refrigerant (see part C, section 12C01).
7. Run the system and check if it operates normally.

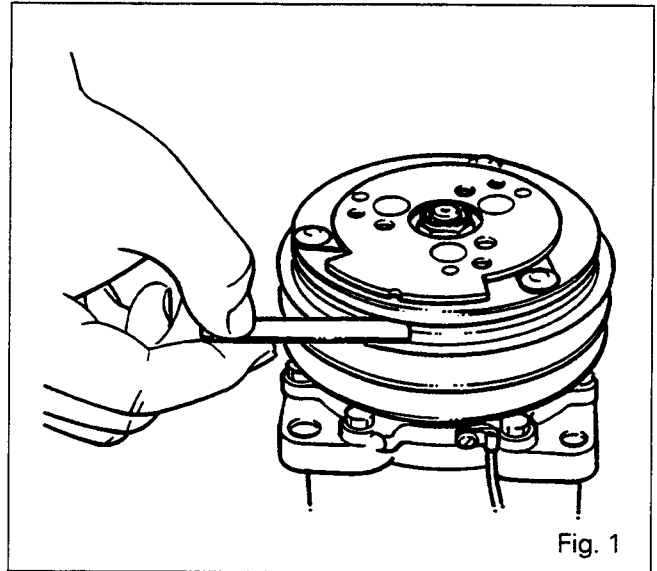

Fig. 1

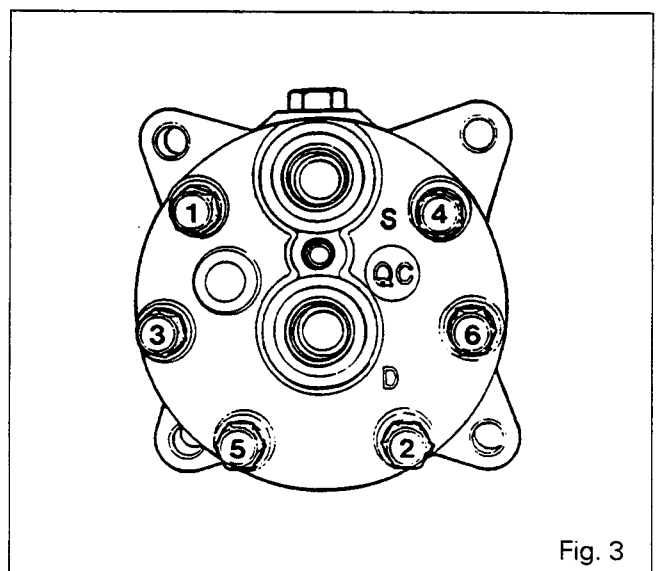
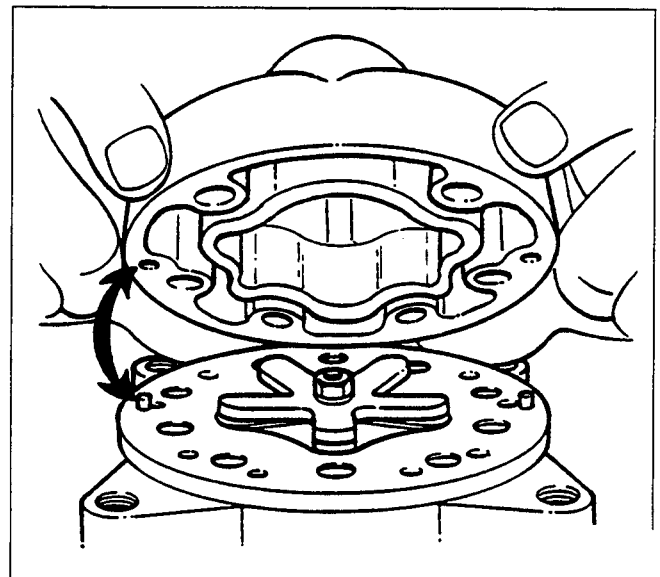

Fig. 3